



Description

- Ai1003 is a vertical clock driver with 3 levels of output voltage processed in a standard CMOS

Feature

- 3 Levels of output voltage, 15V, 0V, -8.5V
- 3.3V / 5V input voltage

Pin Configuration

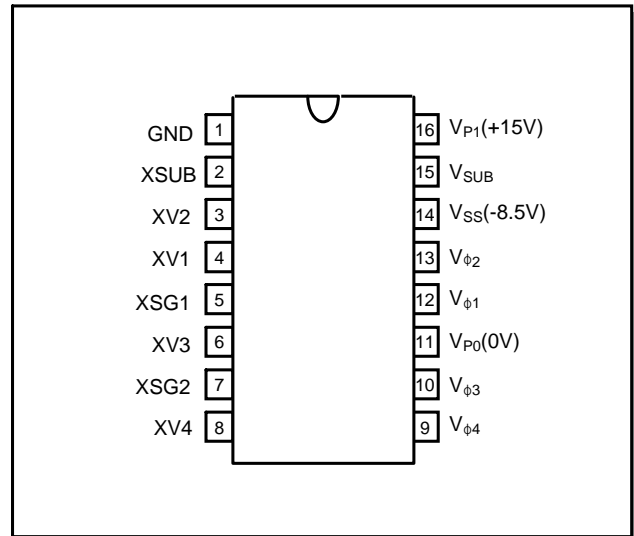

**16 PIN TSSOP
(Top View)**

Absolute Maximum Ratings

Parameter	Symbol	Rating			Unit
		Min	Typ	Max	
Supply Voltage	V_{SS}	-10		0	V
	V_{P1}	-0.3		$V_{SS}+30$	V
	V_{P0}	$V_{SS}-0.3$		3	V
Input Voltage	V_I	-0.3		$V_{P1}+0.3$	V
Output Voltage	V_1, V_3, V_{SUB}	$V_{SS}-0.3$		$V_{P1}+0.3$	V
	V_2, V_4	$V_{SS}-0.3$		$V_{P1}+0.3$	V
Operating Ambient Temperature	T_a	-25		85	°C
Storage Temperature	T_s	-45		125	°C

NOTE : Stress above those listed under "Absolute Maximum Rating" may cause permanent damage to the device. This is a stress rating only and functional operation of the device at these or any other conditions above those indicated in the operational section of this specification is not implied. Exposure to absolute maximum rating conditions for the extended periods of time may affect device reliability.

Block Diagram

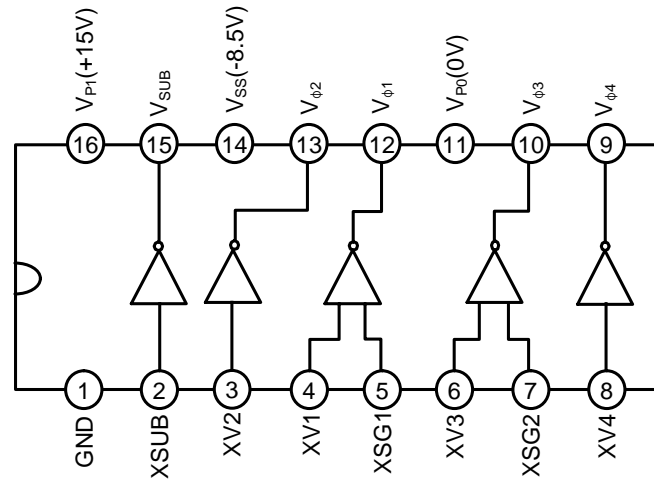

Logic Truth Table

Input				Output		
XV1, 2	XSG1, 2	XV2, 4	XSUB	V _{φ1,3}	V _{φ2,4}	V _{SUB}
L L H H	L H L H			V _{P1} V _{P0} *Z V _{SS}		
		L H			V _{P0} V _{SS}	
			L H			V _{P1} V _{SS}

* Z is high impedance.

Pin Description

No.	Symbol	I/O	Description
1	GND	-	GND
2	XSUB	I	Input signal pin - control V _{SUB}
3	XV2	I	Input signal pin - control V _{φ2}
4	XV1	I	Input signal pin - control V _{φ1}
5	XSG1	I	Input signal pin - control V _{φ1}
6	XV3	I	Input signal pin - control V _{φ3}
7	XSG2	I	Input signal pin - control V _{φ3}
8	XV4	I	Input signal pin - control V _{φ4}
9	V _{φ4}	O	Output signal pin - 2 level (V _{P0} , V _{SS})
10	V _{φ3}	O	Output signal pin - 3 level (V _{P1} , V _{P0} , V _{SS})
11	V _{P0}	-	Power supply (0V)
12	V _{φ1}	O	Output signal pin - 3 level (V _{P1} , V _{P0} , V _{SS})
13	V _{φ2}	O	Output signal pin - 2 level (V _{P0} , V _{SS})
14	V _{SS}	-	Power supply (-8.5V)
15	V _{SUB}	O	Output signal pin - 2 level (V _{P1} , V _{SS})
16	V _{P1}	-	Power supply (+15V)

DC Characteristics(T_A=25°C, V_{DD} = 5V, V_{SS} = -8.5V, V_{P0} =GND, V_{P1} = 15V)

Parameter	Symbol	Value			Unit	Condition
		Min	Typ	Max		
Power Supply	V _{P1}	14.5	15	15.5	V	
	V _{SS}	-9.5	-8.5	-7.5	V	
Supply Current	I _{P1}		2.4	6	mA	(*1)
	I _{SS}	-8	-4.2		mA	
	I _{P0}		0.6	2.5	mA	
Input Voltage	V _{IH}	2.3			V	
	V _{IL}			1.2	V	
Input Current	I _I	-1	0	1	μA	V _{IN} =0~5V (*2)
Output Current	I _{OL}	24	30		mA	V _{1~4} = -8.0V
	I _{OM1}		-18	-25	mA	V _{1~4} = -0.5V
	I _{OM2}	9	13.5		mA	V _{1,3} = -0.5V
	I _{OH}		-15	-25	mA	V _{1,3} = -0.5V
	I _{OSL}	12	18		mA	V _{SUB} = -8.0V
	I _{OSH}		-10	-7	mA	V _{SUB} = 14.5V

(*1) : Refer to the measurement circuit. Shutter speed : 1/40μs

(*2) : XV1~4, XSG1,2, XSUB pins

Measurement Circuit

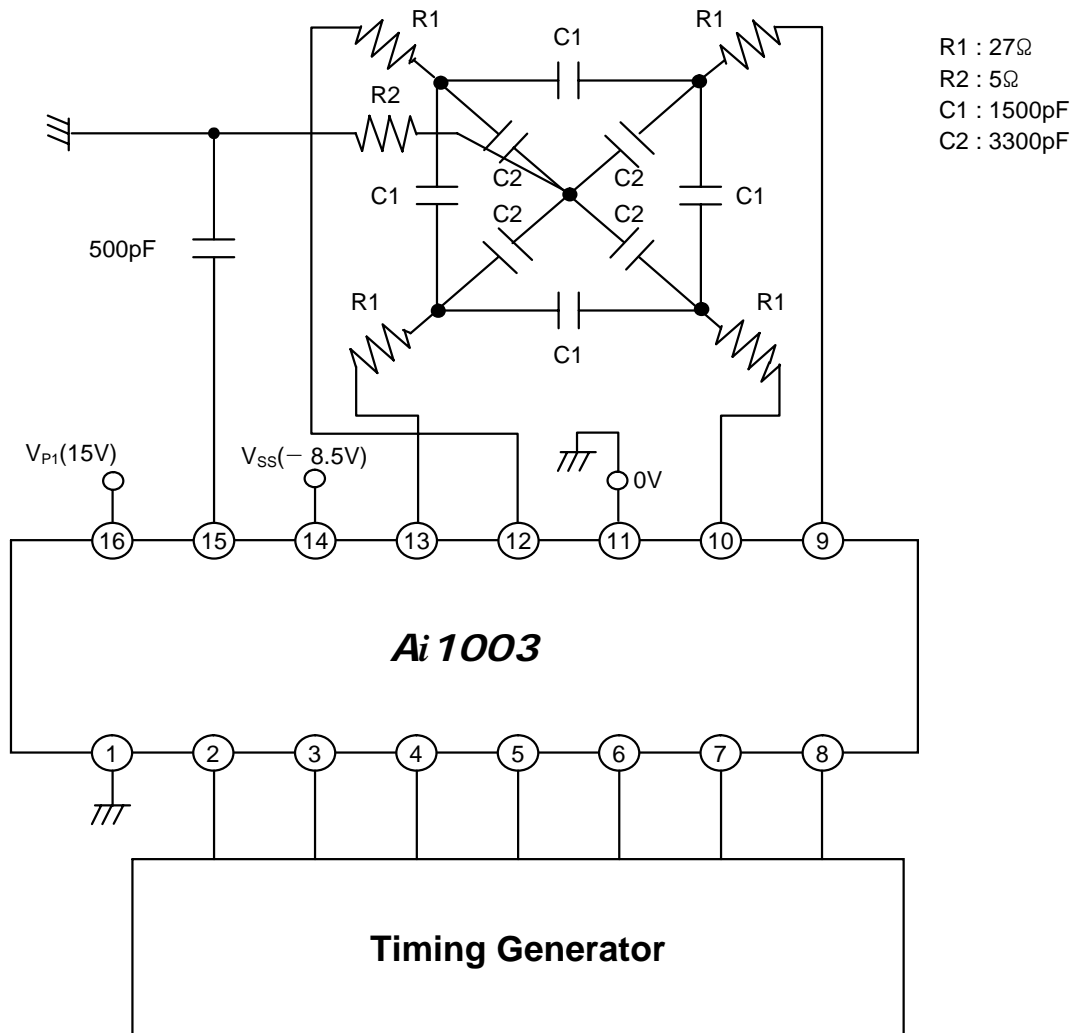

AC Characteristics

($T_A=25^{\circ}\text{C}$, $V_{DD} = 5\text{V}$, $V_{SS} = -8.5\text{V}$, $V_{P0} = \text{GND}$, $V_{P1} = 15\text{V}$)

Parameter	Symbol	Value			Unit	Condition
		Min	Typ	Max		
Delay Time	T_{PLM}	100	140	190	ns	No Load (*1)
	T_{PMH}	100	140	190	ns	
	T_{PLH}	110	150	210	ns	
	T_{PML}	190	250	310	ns	
	T_{PHM}	190	250	310	ns	
	T_{PHL}	150	220	270	ns	
Transition Time	T_{TLM}	170	250	330	ns	V_{SS} V_{P0} (*1)
	T_{TMH}	190	240	310	ns	V_{P0} V_{P1} (*1)
	T_{TLH}	100	150	210	ns	V_{SS} V_{P1} (*1)
	T_{TML}	100	200	310	ns	V_{P0} V_{SS} (*1)
	T_{THM}	60	110	170	ns	V_{P1} V_{P0} (*1)
	T_{THL}	90	140	210	ns	V_{P1} V_{SS} (*1)
Output Noise Voltage	V_{CLH} , V_{CCL} V_{CMH} , V_{CML}			0.5	V	(*2)

(*1) : Refer to Timing Diagram

(*2) : Refer to Noise Diagram

Noise Diagram

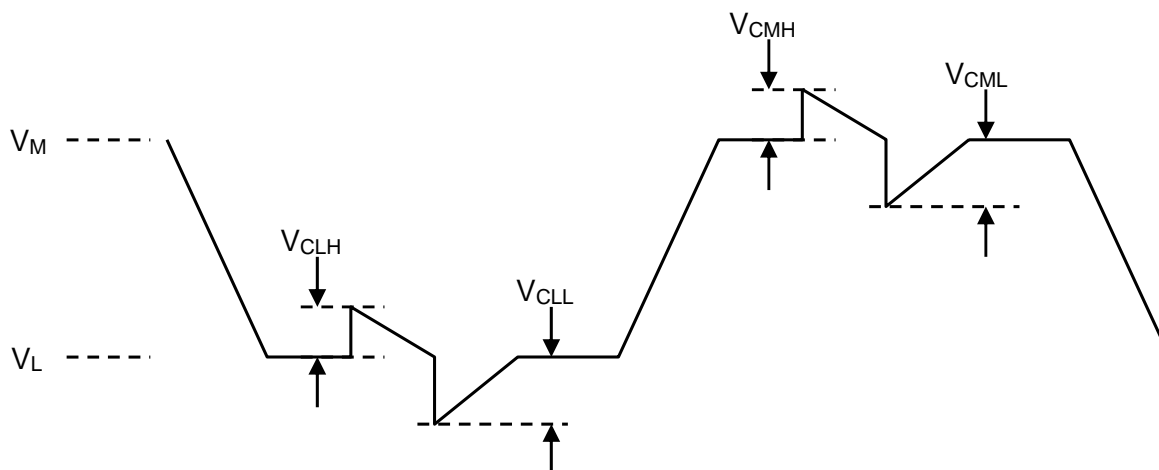

Application Circuit

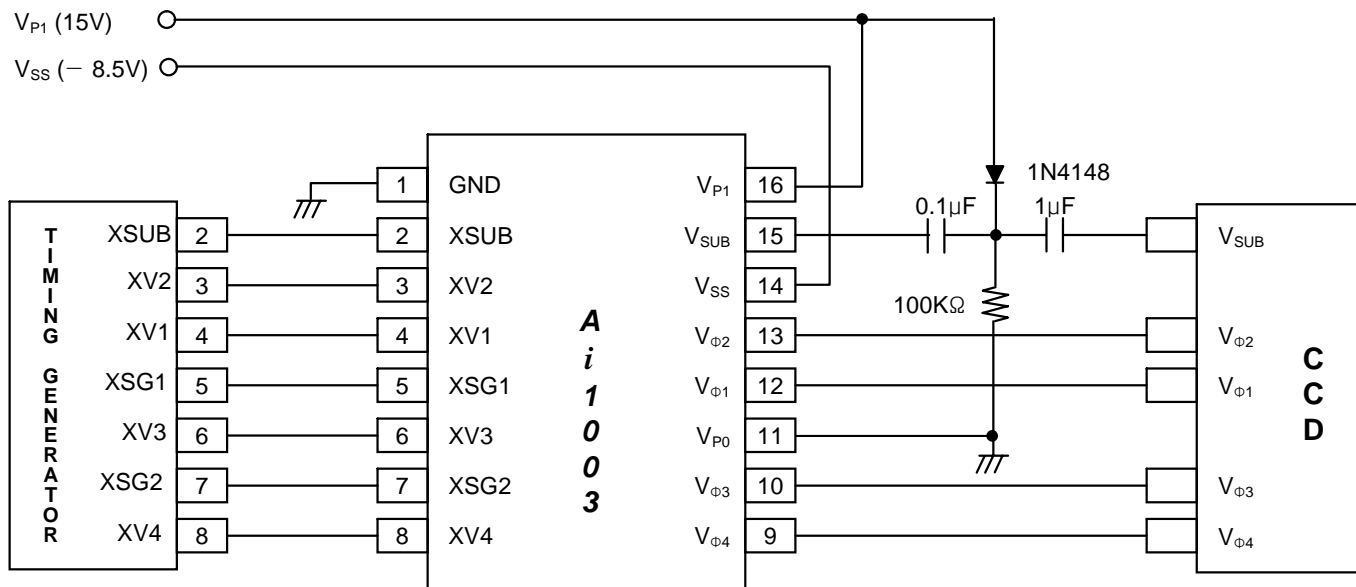

* **Warning** : When voltage is biased, You must keep this flow. If you don't keep this flow, Negative voltage is applied to CCD image sensor's SUB.

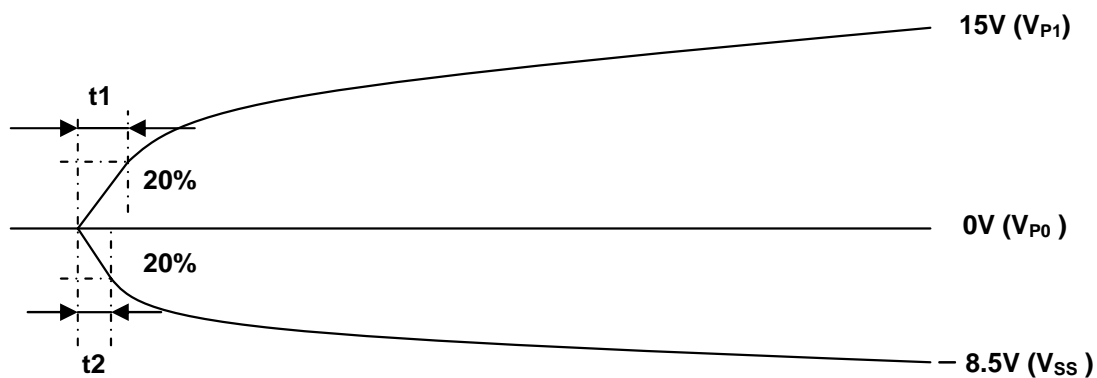

* $t1 \geq t2 \geq 10ms$

Package Dimension (Ai1003 : 16 PIN TSSOP)

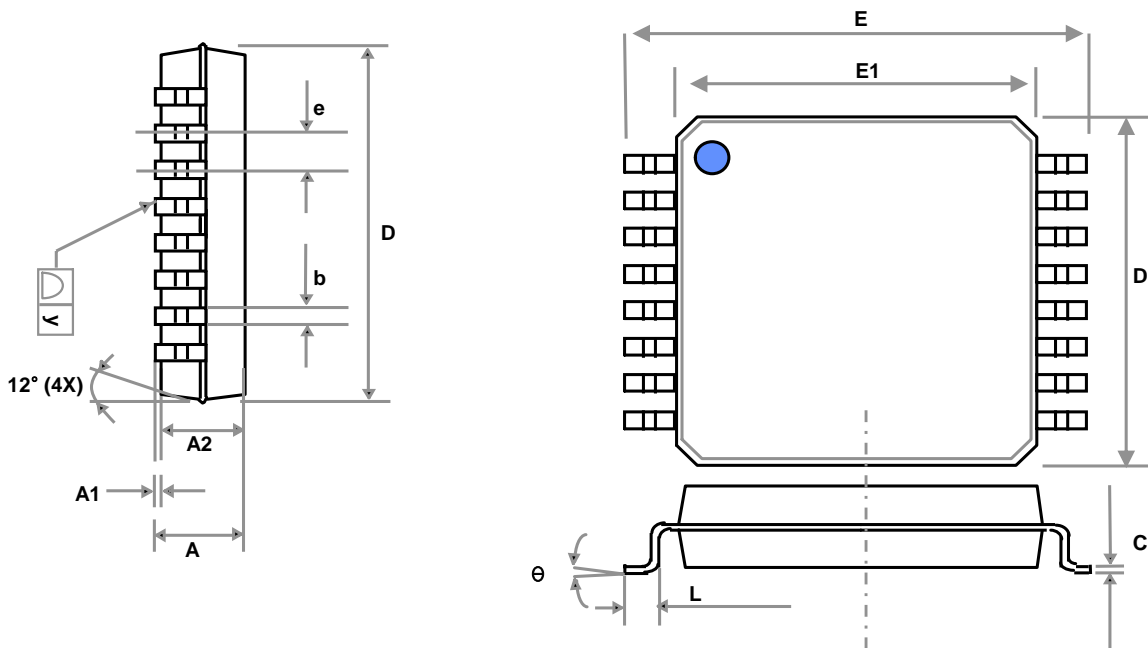

NOTE:

1. PACKAGE BODY SIZES EXCLUDE MOLD FLASH PROTRUSIONS OR GATE BURRS
2. TOLERANCE $\pm 0.1\text{mm}$ UNLESS OTHERWISE SPECIFIED
3. COPLANARITY : 0.1mm
4. CONTROLLOMG DIMENSION IS MILLIMETER. CONVERTED INCH DIMENSIONS ARE NOT NECESSARILY EXACT.
5. FOLLOWED FROM JEDEC MO-153

SYMBOLS	DIMENSIONS IN MILLIMETERS			DIMENSIONS IN INCHES		
	MIN	NOM	MAX	MIN	NOM	MAX
A	-	-	1.20	-	-	0.048
A1	0.05	-	0.15	0.002	-	0.006
A2	0.80	1.00	1.05	0.031	0.039	0.041
b	0.19	-	0.30	0.007	-	0.012
C	0.09	-	0.20	0.004	-	0.008
D	4.90	5.00	5.10	0.193	0.197	0.201
E	6.20	6.40	6.60	0.244	0.252	0.260
E1	4.30	4.40	4.50	0.169	0.173	0.177
e	-	0.65	-	-	0.026	-
L	0.45	0.60	0.75	0.018	0.024	0.030
y	-	-	0.10	-	-	0.004
	0°	-	8°	0	-	8°