

# Dual Synchronous 800mA, 2.25MHz Step-Down DC/DC Regulator

## FEATURES

- High Efficiency: Up to 95%
- Low Ripple (<math><35\text{mV}\_{\text{PK-PK}}</math>) Burst Mode Operation;  $I_Q = 40\mu\text{A}$
- 2.25MHz Constant Frequency Operation
- No Schottky Diodes Required
- Low  $R_{\text{DS(ON)}}$  Internal Switches: 0.35 $\Omega$
- Current Mode Operation for Excellent Line and Load Transient Response
- Short-Circuit Protected
- Low Dropout Operation: 100% Duty Cycle
- Ultralow Shutdown Current:  $I_Q < 1\mu\text{A}$
- Output Voltages from 5V down to 0.6V
- Power-On Reset Output
- Externally Synchronizable Oscillator
- Optional External Soft-Start
- Small Thermally Enhanced MSOP and 3mm  $\times$  3mm DFN Packages

## APPLICATIONS

- PDAs/Palmtop PCs
- Digital Cameras
- Cellular Phones
- Wireless and DSL Modems

## DESCRIPTION

The LTC<sup>®</sup>3407A-2 is a dual, constant frequency, synchronous step-down DC/DC converter. Intended for low power applications, it operates from a 2.5V to 5.5V input voltage range and has a constant 2.25MHz switching frequency, enabling the use of tiny, low cost capacitors and inductors 1mm or less in height. Each output voltage is adjustable from 0.6V to 5V. Internal synchronous 0.35 $\Omega$ , 1A power switches provide high efficiency without the need for external Schottky diodes.

A user selectable mode input is provided to allow the user to trade-off ripple noise for low power efficiency. Burst Mode<sup>®</sup> operation provides the highest efficiency at light loads, while Pulse Skip Mode provides the lowest ripple noise at light loads.

To further maximize battery life, the P-channel MOSFETs are turned on continuously in dropout (100% duty cycle), and both channels draw a total quiescent current of only 40 $\mu\text{A}$ . In shutdown, the device draws <math><1\mu\text{A}</math>.

LT, LT, LTC, LTM and Burst Mode are registered trademarks of Linear Technology Corporation. All other trademarks are the property of their respective owners. Protected by U.S. Patents including 5481178, 6580258, 6304066, 6127815, 6498466, 6611131.

## TYPICAL APPLICATION

1mm High 2.5V/1.8V at 800mA Step-Down Regulators

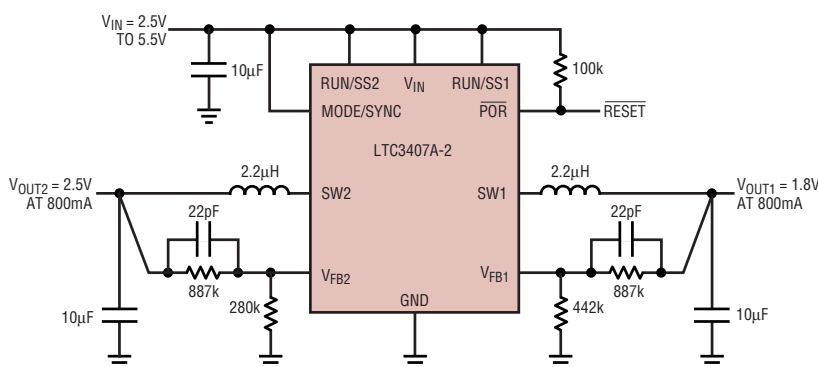

Efficiency/Power Loss Curve

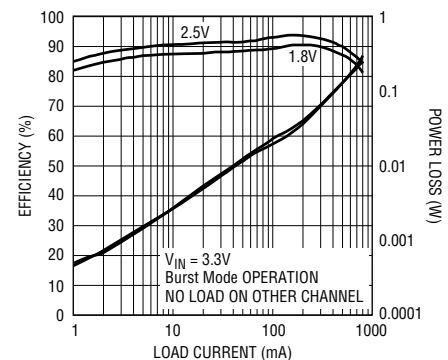

3407A2 TA01

3407A2 TA02

## ABSOLUTE MAXIMUM RATINGS

(Note 1)

$V_{IN}$ Voltage .....	-0.3V to 6V
$V_{FB1}$ , $V_{FB2}$ Voltages .....	-0.3V to 1.5V
RUN/SS1, RUN/SS2 Voltages .....	-0.3V to $V_{IN}$
MODE/SYNC Voltage .....	-0.3V to $V_{IN}$
SW1, SW2 Voltages .....	-0.3V to $V_{IN} + 0.3V$
POR Voltage .....	-0.3V to 6V

Operating Temperature Range (Note 2)	
LTC3407AE-2 .....	-40°C to 85°C
LTC3407AI-2 .....	-40°C to 125°C
Junction Temperature (Note 5) .....	125°C
Storage Temperature Range .....	-65°C to 150°C
Lead Temperature (Soldering, 10 sec)	
LTC3407AEMSE-2 .....	300°C
LTC3407AIMSE-2 .....	300°C

## PIN CONFIGURATION

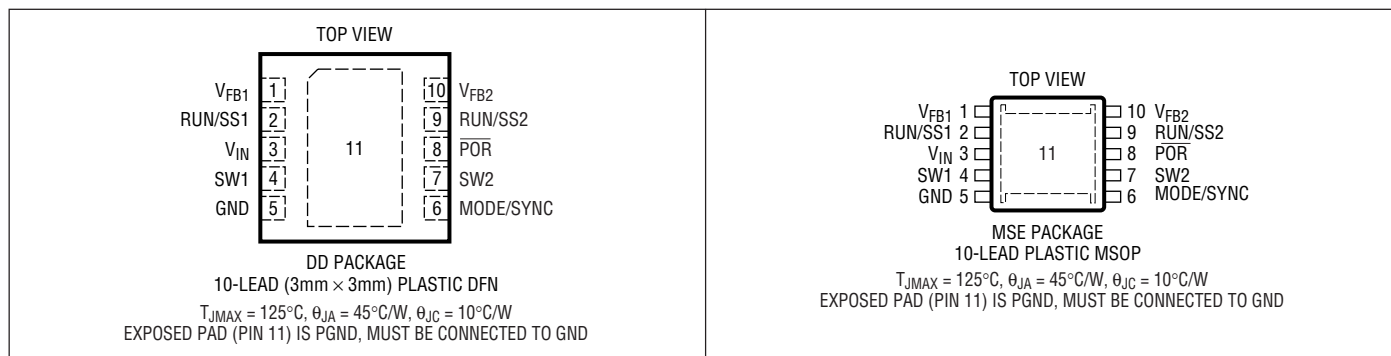

## ORDER INFORMATION

LEAD FREE FINISH	TAPE AND REEL	PART MARKING*	PACKAGE DESCRIPTION	TEMPERATURE RANGE
LTC3407AEDD-2#PBF	LTC3407AEDD-2#TRPBF	LDDH	10-Lead (3mm × 3mm) Plastic DFN	-40°C to 85°C
LTC3407AEMSE-2#PBF	LTC3407AEMSE-2#TRPBF	LTDDJ	10-Lead Plastic MSOP	-40°C to 85°C
LTC3407AIDD-2#PBF	LTC3407AIDD-2#TRPBF	LDDH	10-Lead (3mm × 3mm) Plastic DFN	-40°C to 125°C
LTC3407AIMSE-2#PBF	LTC3407AIMSE-2#TRPBF	LTDDJ	10-Lead Plastic MSOP	-40°C to 125°C
LEAD BASED FINISH	TAPE AND REEL	PART MARKING*	PACKAGE DESCRIPTION	TEMPERATURE RANGE
LTC3407AEDD-2	LTC3407AEDD-2#TR	LDDH	10-Lead (3mm × 3mm) Plastic DFN	-40°C to 85°C
LTC3407AEMSE-2	LTC3407AEMSE-2#TR	LTDDJ	10-Lead Plastic MSOP	-40°C to 85°C
LTC3407AIDD-2	LTC3407AIDD-2#TR	LDDH	10-Lead (3mm × 3mm) Plastic DFN	-40°C to 125°C
LTC3407AIMSE-2	LTC3407AIMSE-2#TR	LTDDJ	10-Lead Plastic MSOP	-40°C to 125°C

Consult LTC Marketing for parts specified with wider operating temperature ranges. \*The temperature grade is identified by a label on the shipping container. For more information on lead free part marking, go to: <http://www.linear.com/leadfree/>  
For more information on tape and reel specifications, go to: <http://www.linear.com/tapeandreel/>

## ELECTRICAL CHARACTERISTICS

The ● denotes the specifications which apply over the full operating temperature range, otherwise specifications are at  $T_A = 25^\circ\text{C}$ .  $V_{IN} = 3.6\text{V}$ , unless otherwise specified. (Note 2)

SYMBOL	PARAMETER	CONDITIONS	MIN	TYP	MAX	UNITS
$V_{IN}$	Operating Voltage Range		● 2.5		5.5	V
$I_{FB}$	Feedback Pin Input Current		●		30	nA
$V_{FB}$	Feedback Voltage (Note 3)	$0^\circ\text{C} \leq T_A \leq 85^\circ\text{C}$	● 0.588	0.6	0.612	V
		$-40^\circ\text{C} \leq T_A \leq 125^\circ\text{C}$ (Note 2)	● 0.585	0.6	0.612	V
$\Delta V_{LINE REG}$	Reference Voltage Line Regulation	$V_{IN} = 2.5\text{V}$ to $5.5\text{V}$ (Note 3)		0.3	0.5	%/V
$\Delta V_{LOAD REG}$	Output Voltage Load Regulation	MODE/SYNC = 0V (Note 3)		0.5		%
$I_S$	Input DC Supply Current Active Mode Sleep Mode Shutdown	(Note 4) $V_{FB1} = V_{FB2} = 0.5\text{V}$		700	950	$\mu\text{A}$
		$V_{FB1} = V_{FB2} = 0.63\text{V}$ , MODE/SYNC = 3.6V		40	60	$\mu\text{A}$
		RUN = 0V, $V_{IN} = 5.5\text{V}$ , MODE/SYNC = 0V		0.1	1	$\mu\text{A}$
$f_{OSC}$	Oscillator Frequency	$V_{FBX} = 0.6\text{V}$	● 1.8	2.25	2.7	MHz
$f_{SYNC}$	Synchronization Frequency			2.25		MHz
$I_{LIM}$	Peak Switch Current Limit	$V_{IN} = 3\text{V}$ , $V_{FBX} = 0.5\text{V}$ , Duty Cycle <35%	1	1.2	1.6	A
$R_{DS(ON)}$	Top Switch On-Resistance	(Note 6)		0.35	0.45	$\Omega$
	Bottom Switch On-Resistance	(Note 6)		0.30	0.45	$\Omega$
$I_{SW(LKG)}$	Switch Leakage Current	$V_{IN} = 5\text{V}$ , $V_{RUN} = 0\text{V}$ , $V_{FBX} = 0\text{V}$		0.01	1	$\mu\text{A}$
POR	Power-On Reset Threshold	$V_{FBX}$ Ramping Up, MODE/SYNC = 0V		8.5		%
		$V_{FBX}$ Ramping Down, MODE/SYNC = 0V		-8.5		%
		Power-On Reset On-Resistance		100	200	$\Omega$
	Power-On Reset Delay			65,536		Cycles
$V_{RUN}$	RUN/SS Threshold Low		● 0.3	1	1.5	V
	RUN/SS Threshold High		●		2	V
$I_{RUN}$	RUN/SS Leakage Current		●	0.01	1	$\mu\text{A}$
$V_{MODE}$	MODE Threshold Low		0		0.5	V
	MODE Threshold High		$V_{IN} - 0.5$		$V_{IN}$	V

**Note 1:** Stresses beyond those listed under Absolute Maximum Ratings may cause permanent damage to the device. Exposure to any Absolute Maximum Rating condition for extended periods may affect device reliability and lifetime.

**Note 2:** The LTC3407AE-2 is guaranteed to meet specified performance from  $0^\circ\text{C}$  to  $85^\circ\text{C}$ . Specifications over the  $-40^\circ\text{C}$  and  $85^\circ\text{C}$  operating temperature range are assured by design, characterization and correlation with statistical process controls. The LTC3407AI-2 is guaranteed over the full  $-40^\circ\text{C}$  to  $125^\circ\text{C}$  operating temperature range.

**Note 3:** The LTC3407A-2 is tested in a proprietary test mode that connects  $V_{FB}$  to the output of the error amplifier.

**Note 4:** Dynamic supply current is higher due to the internal gate charge being delivered at the switching frequency.

**Note 5:**  $T_J$  is calculated from the ambient  $T_A$  and power dissipation  $P_D$  according to the following formula:  $T_J = T_A + (P_D \cdot \theta_{JA})$ .

**Note 6:** The DFN switch on-resistance is guaranteed by correlation to wafer level measurements.

**TYPICAL PERFORMANCE CHARACTERISTICS**  $T_A = 25^\circ\text{C}$  unless otherwise specified.

**Burst Mode Operation**

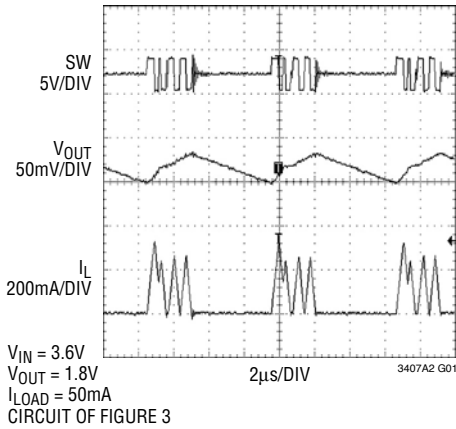

**Pulse Skipping Mode**

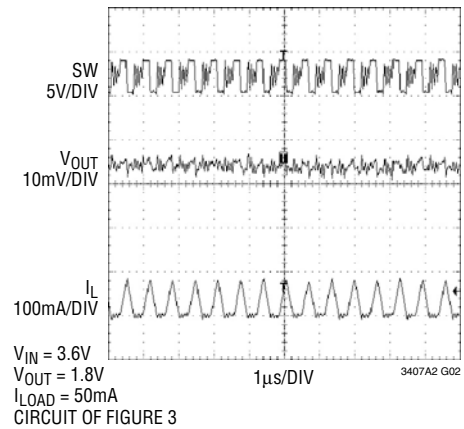

**Load Step**

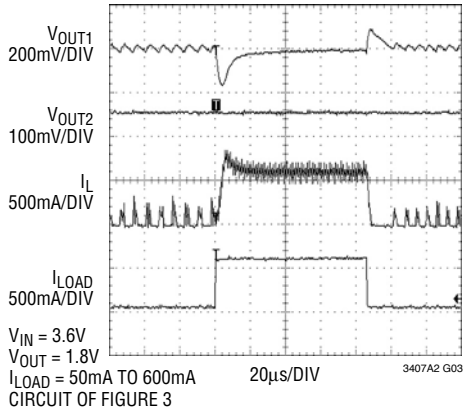

**Soft Start**

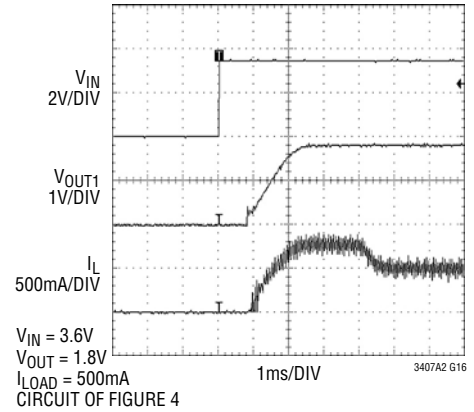

**Efficiency vs Input Voltage**

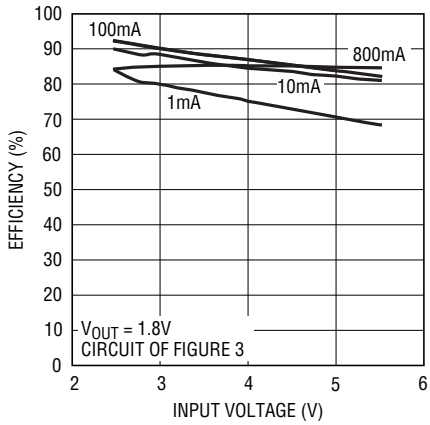

3407A2 G04

**Oscillator Frequency vs Temperature**

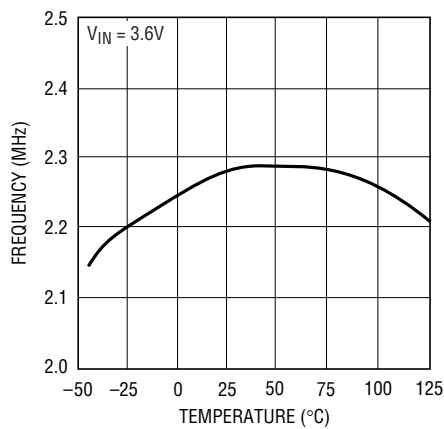

3407A2 G05

**Oscillator Frequency vs Supply Voltage**

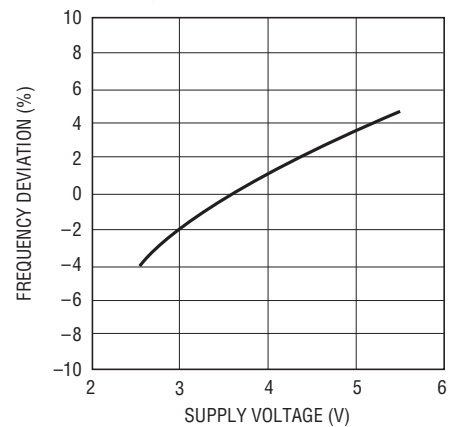

3407A2 G06

**TYPICAL PERFORMANCE CHARACTERISTICS**  $T_A = 25^\circ\text{C}$  unless otherwise specified.

**Reference Voltage vs Temperature**

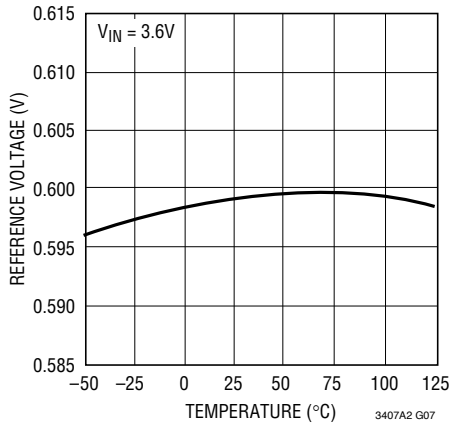

**$R_{DS(ON)}$  vs Input Voltage**

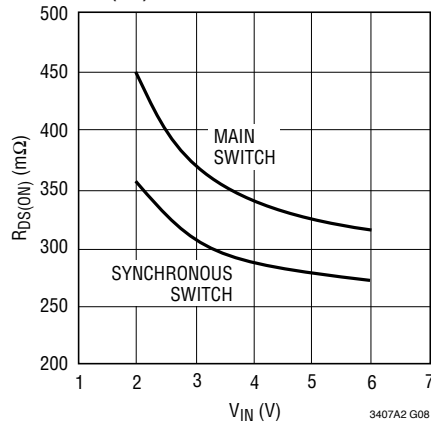

**$R_{DS(ON)}$  vs Temperature**

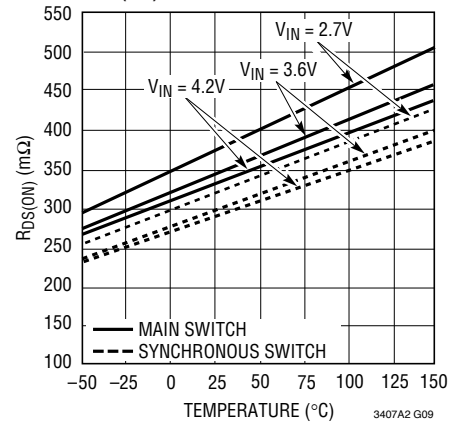

**Efficiency vs Load Current**

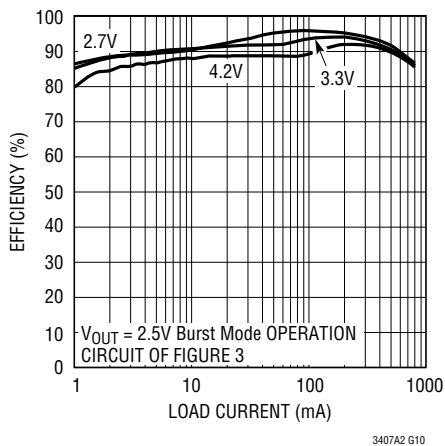

**Efficiency vs Load Current**

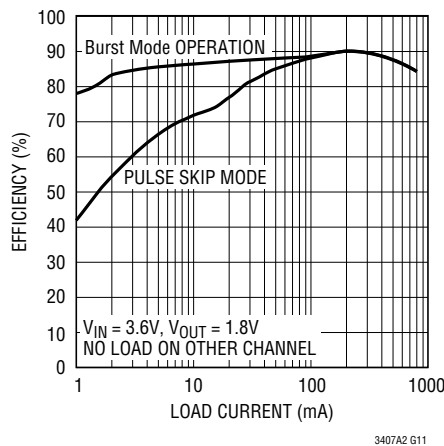

**Load Regulation**

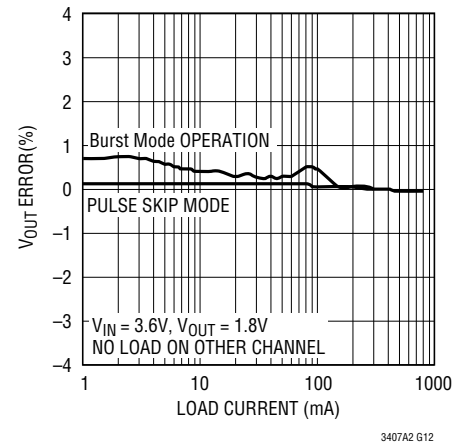

**Efficiency vs Load Current**

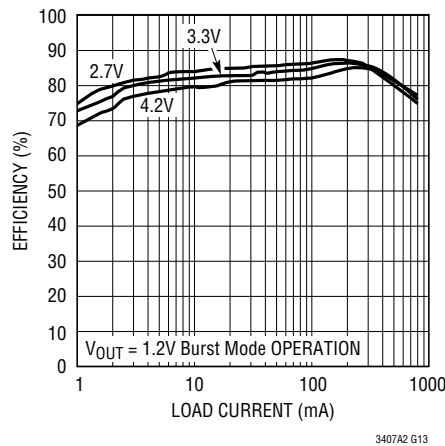

**Efficiency vs Load Current**

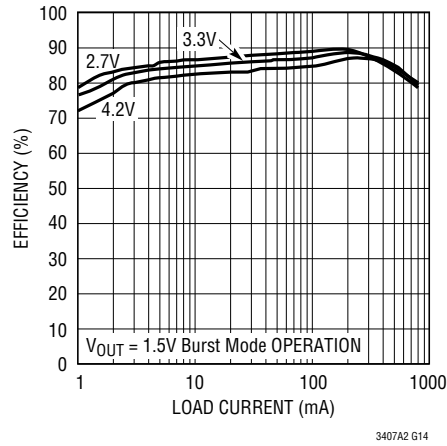

**Line Regulation**

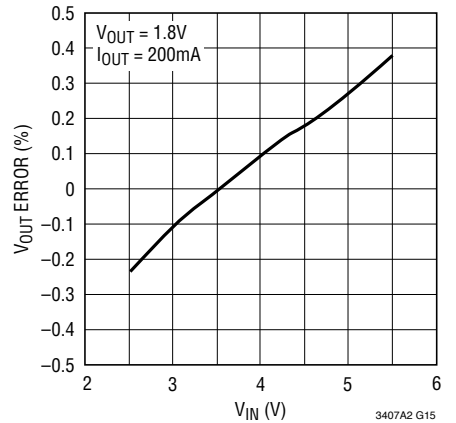

## PIN FUNCTIONS

**V<sub>FB1</sub> (Pin 1):** Output Feedback. Receives the feedback voltage from the external resistive divider across the output. Nominal voltage for this pin is 0.6V.

**RUN/SS1 (Pin 2):** Regulator 1 Enable and Soft-Start Input. Forcing this pin to V<sub>IN</sub> enables regulator 1, while forcing it to GND causes regulator 1 to shut down. Connect external RC-network with desired time-constant to enable soft-start feature. This pin must be driven; do not float.

**V<sub>IN</sub> (Pin 3):** Main Power Supply. Must be closely decoupled to GND.

**SW1 (Pin 4):** Regulator 1 Switch Node Connection to the Inductor. This pin swings from V<sub>IN</sub> to GND.

**GND (Pin 5):** Main Ground. Connect to the (–) terminal of C<sub>OUT</sub>, and (–) terminal of C<sub>IN</sub>.

**MODE/SYNC (Pin 6):** Combination Mode Selection and Oscillator Synchronization. This pin controls the operation of the device. When tied to V<sub>IN</sub> or GND, Burst Mode operation or pulse skipping mode is selected, respectively. Do not float this pin. The oscillation frequency can

be synchronized to an external oscillator applied to this pin and pulse skipping mode is automatically selected.

**SW2 (Pin 7):** Regulator 2 Switch Node Connection to the Inductor. This pin swings from V<sub>IN</sub> to GND.

**POR (Pin 8):** Power-On Reset. This common-drain logic output is pulled to GND when the output voltage is not within  $\pm 8.5\%$  of regulation and goes high after 2<sup>16</sup> clock cycles when both channels are within regulation.

**RUN/SS2 (Pin 9):** Regulator 2 Enable and Soft-Start Input. Forcing this pin to V<sub>IN</sub> enables regulator 2, while forcing it to GND causes regulator 2 to shut down. Connect external RC-Network with desired time-constant to enable soft-start feature. This pin must be driven; do not float.

**V<sub>FB2</sub> (Pin 10):** Output Feedback. Receives the feedback voltage from the external resistive divider across the output. Nominal voltage for this pin is 0.6V.

**Exposed Pad (GND) (Pin 11):** Power Ground. Connect to the (–) terminal of C<sub>OUT</sub>, and (–) terminal of C<sub>IN</sub>. Must be soldered to electrical ground on PCB.

## BLOCK DIAGRAM

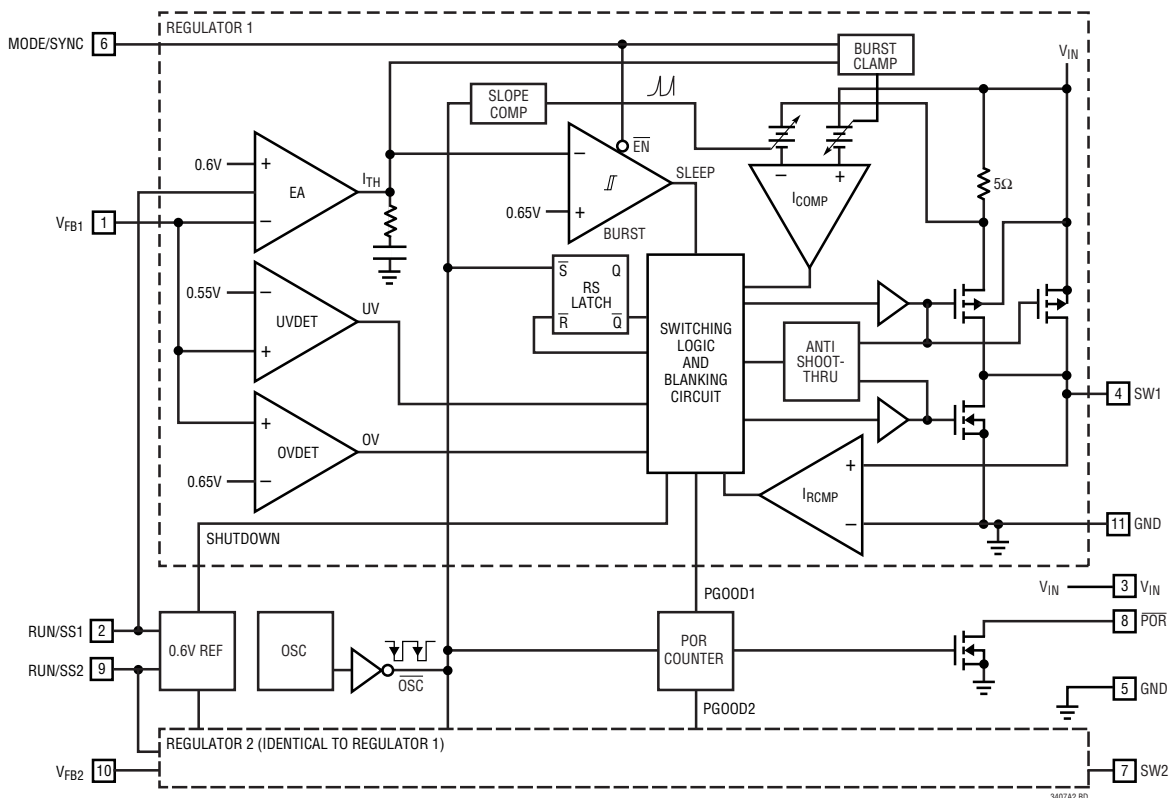

3407a2f

## OPERATION

The LTC3407A-2 uses a constant frequency, current mode architecture. The operating frequency is set at 2.25MHz and can be synchronized to an external oscillator. Both channels share the same clock and run in-phase. To suit a variety of applications, the selectable MODE/SYNC pin allows the user to trade-off noise for efficiency.

The output voltage is set by an external divider returned to the  $V_{FB}$  pins. An error amplifier compares the divided output voltage with a reference voltage of 0.6V and adjusts the peak inductor current accordingly. Overvoltage and undervoltage comparators will pull the  $\overline{POR}$  output low if the output voltage is not within  $\pm 8.5\%$ . The  $\overline{POR}$  output will go high after 65,536 clock cycles (about 29ms in pulse skipping mode) of achieving regulation.

### Main Control Loop

During normal operation, the top power switch (P-channel MOSFET) is turned on at the beginning of a clock cycle when the  $V_{FB}$  voltage is below the reference voltage. The current into the inductor and the load increases until the current limit is reached. The switch turns off and energy stored in the inductor flows through the bottom switch (N-channel MOSFET) into the load until the next clock cycle.

The peak inductor current is controlled by the internally compensated  $I_{TH}$  voltage, which is the output of the error amplifier. This amplifier compares the  $V_{FB}$  pin to the 0.6V reference. When the load current increases, the  $V_{FB}$  voltage decreases slightly below the reference. This decrease causes the error amplifier to increase the  $I_{TH}$  voltage until the average inductor current matches the new load current.

The main control loop is shut down by pulling the RUN/SS pin to ground.

### Low Current Operation

Two modes are available to control the operation of the LTC3407A-2 at low currents. Both modes automatically switch from continuous operation to the selected mode when the load current is low.

To optimize efficiency, the Burst Mode operation can be selected. When the load is relatively light, the LTC3407A-2

automatically switches into Burst Mode operation in which the PMOS switch operates intermittently based on load demand with a fixed peak inductor current. By running cycles periodically, the switching losses which are dominated by the gate charge losses of the power MOSFETs are minimized. The main control loop is interrupted when the output voltage reaches the desired regulated value. A voltage comparator trips when  $I_{TH}$  is below 0.65V, shutting off the switch and reducing the power. The output capacitor and the inductor supply the power to the load until  $I_{TH}$  exceeds 0.65V, turning on the switch and the main control loop which starts another cycle.

For lower ripple noise at low currents, the pulse skipping mode can be used. In this mode, the LTC3407A-2 continues to switch at a constant frequency down to very low currents, where it will begin skipping pulses.

### Dropout Operation

When the input supply voltage decreases toward the output voltage, the duty cycle increases to 100% which is the dropout condition. In dropout, the PMOS switch is turned on continuously with the output voltage being equal to the input voltage minus the voltage drops across the internal P-channel MOSFET and the inductor.

An important design consideration is that the  $R_{DS(ON)}$  of the P-channel switch increases with decreasing input supply voltage (See Typical Performance Characteristics). Therefore, the user should calculate the power dissipation when the LTC3407A-2 is used at 100% duty cycle with low input voltage (See Thermal Considerations in the Applications Information Section).

### Low Supply Operation

The LTC3407A-2 incorporates an undervoltage lockout circuit which shuts down the part when the input voltage drops below about 1.65V to prevent unstable operation.

A general LTC3407A-2 application circuit is shown in Figure 1. External component selection is driven by the load requirement, and begins with the selection of the inductor L. Once the inductor is chosen,  $C_{IN}$  and  $C_{OUT}$  can be selected.

## APPLICATIONS INFORMATION

### Inductor Selection

Although the inductor does not influence the operating frequency, the inductor value has a direct effect on ripple current. The inductor ripple current  $\Delta I_L$  decreases with higher inductance and increases with higher  $V_{IN}$  or  $V_{OUT}$ :

$$\Delta I_L = \frac{V_{OUT}}{f_0 \cdot L} \cdot \left( 1 - \frac{V_{OUT}}{V_{IN}} \right)$$

Accepting larger values of  $\Delta I_L$  allows the use of low inductances, but results in higher output voltage ripple, greater core losses, and lower output current capability. A reasonable starting point for setting ripple current is  $\Delta I_L = 0.3 \cdot I_{LIM}$ , where  $I_{LIM}$  is the peak switch current limit. The largest ripple current  $\Delta I_L$  occurs at the maximum input voltage. To guarantee that the ripple current stays below a specified maximum, the inductor value should be chosen according to the following equation:

$$L = \frac{V_{OUT}}{f_0 \cdot \Delta I_L} \cdot \left( 1 - \frac{V_{OUT}}{V_{IN(MAX)}} \right)$$

The inductor value will also have an effect on Burst Mode operation. The transition from low current operation begins when the peak inductor current falls below a level set by the burst clamp. Lower inductor values result in higher ripple current which causes this transition to occur at lower load currents. This causes a dip in efficiency in the upper range of low current operation. In Burst Mode operation, lower inductance values will cause the burst frequency to increase.

### Inductor Core Selection

Different core materials and shapes will change the size/current and price/current relationship of an inductor. Toroid or shielded pot cores in ferrite or permalloy materials are small and don't radiate much energy, but generally cost more than powdered iron core inductors with similar electrical characteristics. The choice of which style inductor to use often depends more on the price vs size requirements and any radiated field/EMI requirements than on what the LTC3407A-2 requires to operate. Table 1 shows some typical surface mount inductors that work well in LTC3407A-2 applications.

### Input Capacitor ( $C_{IN}$ ) Selection

In continuous mode, the input current of the converter is a square wave with a duty cycle of approximately  $V_{OUT}/V_{IN}$ . To prevent large voltage transients, a low equivalent series resistance (ESR) input capacitor sized for the maximum RMS current must be used. The maximum RMS capacitor current is given by:

$$I_{RMS} \approx I_{MAX} \frac{\sqrt{V_{OUT}(V_{IN} - V_{OUT})}}{V_{IN}}$$

where the maximum average output current  $I_{MAX}$  equals the peak current minus half the peak-to-peak ripple current,  $I_{MAX} = I_{LIM} - \Delta I_L/2$ .

This formula has a maximum at  $V_{IN} = 2V_{OUT}$ , where  $I_{RMS} = I_{OUT}/2$ . This simple worst-case is commonly used to design because even significant deviations do not offer much relief. Note that capacitor manufacturer's ripple current ratings are often based on only 2000 hours lifetime. This makes it advisable to further derate the capacitor, or choose a capacitor rated at a higher temperature than required. Several capacitors may also be paralleled to meet the size or height requirements of the design. An additional 0.1 $\mu$ F to 1 $\mu$ F ceramic capacitor is also recommended on  $V_{IN}$  for high frequency decoupling, when not using an all ceramic capacitor solution.

**Table 1. Representative Surface Mount Inductors**

MANUFACTURER	PART NUMBER	VALUE	MAX DC CURRENT	DCR	HEIGHT
Taiyo Yuden	CB2016T2R2M	2.2 $\mu$ H	510mA	0.13 $\Omega$	1.6mm
	CB2012T2R2M	2.2 $\mu$ H	530mA	0.33 $\Omega$	1.25mm
	CB2016T3R3M	3.3 $\mu$ H	410mA	0.27 $\Omega$	1.6mm
Panasonic	ELT5KT4R7M	4.7 $\mu$ H	950mA	0.2 $\Omega$	1.2mm
Sumida	CDRH2D18/LD	4.7 $\mu$ H	630mA	0.086 $\Omega$	2mm
Murata	LQH32CN4R7M23	4.7 $\mu$ H	450mA	0.2 $\Omega$	2mm
Taiyo Yuden	NR30102R2M	2.2 $\mu$ H	1100mA	0.1 $\Omega$	1mm
	NR30104R7M	4.7 $\mu$ H	750mA	0.19 $\Omega$	1mm
FDK	FDKMIPF2520D	4.7 $\mu$ H	1100mA	0.11 $\Omega$	1mm
	FDKMIPF2520D	3.3 $\mu$ H	1200mA	0.1 $\Omega$	1mm
	FDKMIPF2520D	2.2 $\mu$ H	1300mA	0.08 $\Omega$	1mm
TDK	VLF3010AT4R7-MR70	4.7 $\mu$ H	700mA	0.28 $\Omega$	1mm
	VLF3010AT3R3-MR87	3.3 $\mu$ H	870mA	0.17 $\Omega$	1mm
	VLF3010AT2R2-M1R0	2.2 $\mu$ H	1000mA	0.12 $\Omega$	1mm

3407a2f



## APPLICATIONS INFORMATION

### Output Capacitor ( $C_{OUT}$ ) Selection

The selection of  $C_{OUT}$  is driven by the required ESR to minimize voltage ripple and load step transients. Typically, once the ESR requirement is satisfied, the capacitance is adequate for filtering. The output ripple ( $\Delta V_{OUT}$ ) is determined by:

$$\Delta V_{OUT} \approx \Delta I_L \left( ESR + \frac{1}{8f_0 C_{OUT}} \right)$$

where  $f_0$  = operating frequency,  $C_{OUT}$  = output capacitance and  $\Delta I_L$  = ripple current in the inductor. The output ripple is highest at maximum input voltage since  $\Delta I_L$  increases with input voltage. With  $\Delta I_L = 0.3 \cdot I_{LIM}$  the output ripple will be less than 100mV at maximum  $V_{IN}$  and  $f_0 = 2.25\text{MHz}$  with:

$$ESR_{C_{OUT}} < 150\text{m}\Omega$$

Once the ESR requirements for  $C_{OUT}$  have been met, the RMS current rating generally far exceeds the  $I_{RIPPLE(P-P)}$  requirement, except for an all ceramic solution.

In surface mount applications, multiple capacitors may have to be paralleled to meet the capacitance, ESR or RMS current handling requirement of the application. Aluminum electrolytic, special polymer, ceramic and dry tantalum capacitors are all available in surface mount packages. The OS-CON semiconductor dielectric capacitor available from Sanyo has the lowest ESR(size) product of any aluminum electrolytic at a somewhat higher price. Special polymer capacitors, such as Sanyo POSCAP, offer very low ESR, but have a lower capacitance density than other types. Tantalum capacitors have the highest capacitance density. However, they also have a larger ESR and it is critical that they are surge tested for use in switching power supplies. An excellent choice is the AVX TPS series of surface mount tantalums, available in case heights ranging from 2mm to 4mm. Aluminum electrolytic capacitors have a significantly larger ESR, and are often used in extremely cost-sensitive applications provided that consideration is given to ripple current ratings and long term reliability. Ceramic capacitors have the lowest ESR and cost, but also have the lowest capacitance density, a high voltage and temperature coefficient, and exhibit audible piezoelectric effects. In addition, the high Q of ceramic capacitors along with

trace inductance can lead to significant ringing. Other capacitor types include the Panasonic Special Polymer (SP) capacitors.

In most cases, 0.1 $\mu\text{F}$  to 1 $\mu\text{F}$  of ceramic capacitors should also be placed close to the LTC3407A-2 in parallel with the main capacitors for high frequency decoupling.

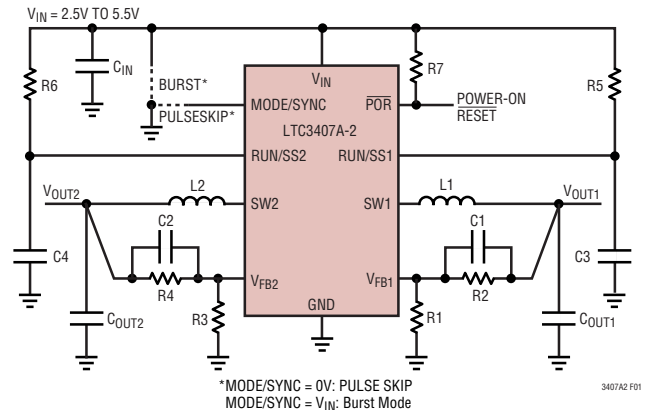

Figure 1. LTC3407A-2 General Schematic

### Ceramic Input and Output Capacitors

Higher value, lower cost ceramic capacitors are now becoming available in smaller case sizes. These are tempting for switching regulator use because of their very low ESR. Unfortunately, the ESR is so low that it can cause loop stability problems. Solid tantalum capacitor ESR generates a loop “zero” at 5kHz to 50kHz that is instrumental in giving acceptable loop phase margin. Ceramic capacitors remain capacitive to beyond 300kHz and usually resonate with their ESL before ESR becomes effective. Also, ceramic caps are prone to temperature effects which requires the designer to check loop stability over the operating temperature range. To minimize their large temperature and voltage coefficients, only X5R or X7R ceramic capacitors should be used. A good selection of ceramic capacitors is available from Taiyo Yuden, TDK, and Murata.

Great care must be taken when using only ceramic input and output capacitors. When a ceramic capacitor is used at the input and the power is being supplied through long wires, such as from a wall adapter, a load step at the output can induce ringing at the  $V_{IN}$  pin. At best, this ringing can couple to the output and be mistaken as loop instability.

## APPLICATIONS INFORMATION

At worst, the ringing at the input can be large enough to damage the part.

Since the ESR of a ceramic capacitor is so low, the input and output capacitor must instead fulfill a charge storage requirement. During a load step, the output capacitor must instantaneously supply the current to support the load until the feedback loop raises the switch current enough to support the load. The time required for the feedback loop to respond is dependent on the compensation and the output capacitor size. Typically, 3-4 cycles are required to respond to a load step, but only in the first cycle does the output drop linearly. The output droop,  $V_{\text{DROOP}}$ , is usually about 3 times the linear drop of the first cycle. Thus, a good place to start is with the output capacitor size of approximately:

$$C_{\text{OUT}} \approx 3 \frac{\Delta I_{\text{OUT}}}{f_0 \cdot V_{\text{DROOP}}}$$

More capacitance may be required depending on the duty cycle and load step requirements.

In most applications, the input capacitor is merely required to supply high frequency bypassing, since the impedance to the supply is very low. A 10 $\mu\text{F}$  ceramic capacitor is usually enough for these conditions.

### Setting the Output Voltage

The LTC3407A-2 develops a 0.6V reference voltage between the feedback pin,  $V_{\text{FB}}$ , and ground as shown in Figure 1. The output voltage is set by a resistive divider according to the following formula:

$$V_{\text{OUT}} = 0.6\text{V} \left( 1 + \frac{R_2}{R_1} \right)$$

Keeping the current small (<5 $\mu\text{A}$ ) in these resistors maximizes efficiency, but making them too small may allow stray capacitance to cause noise problems and reduce the phase margin of the error amp loop.

To improve the frequency response, a feed-forward capacitor  $C_{\text{F}}$  may also be used. Great care should be taken to route the  $V_{\text{FB}}$  line away from noise sources, such as the inductor or the SW line.

### Power-On Reset

The  $\overline{\text{POR}}$  pin is an open-drain output which pulls low when either regulator is out of regulation. When both output voltages are within  $\pm 8.5\%$  of regulation, a timer is started which releases  $\overline{\text{POR}}$  after  $2^{16}$  clock cycles (about 29ms in pulse skipping mode). This delay can be significantly longer in Burst Mode operation with low load currents, since the clock cycles only occur during a burst and there could be milliseconds of time between bursts. This can be bypassed by tying the  $\overline{\text{POR}}$  output to the MODE/SYNC input, to force pulse skipping mode during a reset. In addition, if the output voltage faults during Burst Mode sleep,  $\overline{\text{POR}}$  could have a slight delay for an undervoltage output condition and may not respond to an overvoltage output. This can be avoided by using pulse skipping mode instead. When either channel is shut down, the  $\overline{\text{POR}}$  output is pulled low, since one or both of the channels are not in regulation.

### Mode Selection & Frequency Synchronization

The MODE/SYNC pin is a multipurpose pin which provides mode selection and frequency synchronization. Connecting this pin to  $V_{\text{IN}}$  enables Burst Mode operation, which provides the best low current efficiency at the cost of a higher output voltage ripple. When this pin is connected to ground, pulse skipping operation is selected which provides the lowest output ripple, at the cost of low current efficiency.

The LTC3407A-2 can also be synchronized to another LTC3407A-2 by the MODE/SYNC pin. During synchronization, the mode is set to pulse skipping and the top switch turn-on is synchronized to the rising edge of the external clock.

### Checking Transient Response

The regulator loop response can be checked by looking at the load transient response. Switching regulators take several cycles to respond to a step in load current. When a load step occurs,  $V_{\text{OUT}}$  immediately shifts by an amount equal to  $\Delta I_{\text{LOAD}} \cdot \text{ESR}$ , where ESR is the effective series resistance of  $C_{\text{OUT}}$ .  $\Delta I_{\text{LOAD}}$  also begins to charge or discharge  $C_{\text{OUT}}$  generating a feedback error signal used by the regulator to return  $V_{\text{OUT}}$  to its steady-state value. During

## APPLICATIONS INFORMATION

this recovery time,  $V_{OUT}$  can be monitored for overshoot or ringing that would indicate a stability problem.

The initial output voltage step may not be within the bandwidth of the feedback loop, so the standard second-order overshoot/DC ratio cannot be used to determine phase margin. In addition, a feed-forward capacitor can be added to improve the high frequency response, as shown in Figure 1. Capacitors C1 and C2 provide phase lead by creating high frequency zeros with R2 and R4 respectively, which improve the phase margin.

The output voltage settling behavior is related to the stability of the closed-loop system and will demonstrate the actual overall supply performance. For a detailed explanation of optimizing the compensation components, including a review of control loop theory, refer to Application Note 76.

In some applications, a more severe transient can be caused by switching in loads with large ( $>1\mu\text{F}$ ) input capacitors. The discharged input capacitors are effectively put in parallel with  $C_{OUT}$ , causing a rapid drop in  $V_{OUT}$ . No regulator can deliver enough current to prevent this problem, if the switch connecting the load has low resistance and is driven quickly. The solution is to limit the turn-on speed of the load switch driver. A Hot Swap™ controller is designed specifically for this purpose and usually incorporates current limiting, short-circuit protection, and soft-starting.

### Soft-Start

The RUN/SS pins provide a means to separately run or shut down the two regulators. In addition, they can optionally be used to externally control the rate at which each regulator starts up and shuts down. Pulling the RUN/SS1 pin below 1V shuts down regulator 1 on the LTC3407A-2. Forcing this pin to  $V_{IN}$  enables regulator 1. In order to control the rate at which each regulator turns on and off, connect a resistor and capacitor to the RUN/SS pins as shown in Figure 1. The soft-start duration can be calculated by using the following formula:

$$t_{SS} = R_{SS}C_{SS}\ln\left(\frac{V_{IN}-1}{V_{IN}-1.6}\right) \text{ (s)}$$

For approximately a 1ms ramp time, use  $R_{SS} = 4.7\text{M}\Omega$  and  $C_{SS} = 680\text{pF}$  at  $V_{IN} = 3.3\text{V}$ .

### Efficiency Considerations

The percent efficiency of a switching regulator is equal to the output power divided by the input power times 100%. It is often useful to analyze individual losses to determine what is limiting the efficiency and which change would produce the most improvement. Percent efficiency can be expressed as:

$$\% \text{Efficiency} = 100\% - (L1 + L2 + L3 + \dots)$$

where L1, L2, etc. are the individual losses as a percentage of input power.

Although all dissipative elements in the circuit produce losses, 4 main sources usually account for most of the losses in LTC3407A-2 circuits: 1)  $V_{IN}$  quiescent current, 2) switching losses, 3)  $I^2R$  losses, 4) other losses.

1) The  $V_{IN}$  current is the DC supply current given in the Electrical Characteristics which excludes MOSFET driver and control currents.  $V_{IN}$  current results in a small ( $<0.1\%$ ) loss that increases with  $V_{IN}$ , even at no load.

2) The switching current is the sum of the MOSFET driver and control currents. The MOSFET driver current results from switching the gate capacitance of the power MOSFETs. Each time a MOSFET gate is switched from low to high to low again, a packet of charge  $dQ$  moves from  $V_{IN}$  to ground. The resulting  $dQ/dt$  is a current out of  $V_{IN}$  that is typically much larger than the DC bias current. In continuous mode,  $I_{GATECHG} = f_O(Q_T + Q_B)$ , where  $Q_T$  and  $Q_B$  are the gate charges of the internal top and bottom MOSFET switches. The gate charge losses are proportional to  $V_{IN}$  and thus their effects will be more pronounced at higher supply voltages.

3)  $I^2R$  losses are calculated from the DC resistances of the internal switches,  $R_{SW}$ , and external inductor,  $R_L$ . In continuous mode, the average output current flows through inductor L, but is “chopped” between the internal top and bottom switches. Thus, the series resistance looking into

Hot Swap is a registered trademark of Linear Technology Corporation.

## APPLICATIONS INFORMATION

the SW pin is a function of both top and bottom MOSFET  $R_{DS(ON)}$  and the duty cycle (D) as follows:

$$R_{SW} = (R_{DS(ON)TOP})(D) + (R_{DS(ON)BOT})(1 - D)$$

The  $R_{DS(ON)}$  for both the top and bottom MOSFETs can be obtained from the Typical Performance Characteristics curves. Thus, to obtain  $I^2R$  losses:

$$I^2R \text{ losses} = I_{OUT}^2(R_{SW} + R_L)$$

4) Other 'hidden' losses such as copper trace and internal battery resistances can account for additional efficiency degradations in portable systems. It is very important to include these "system" level losses in the design of a system. The internal battery and fuse resistance losses can be minimized by making sure that  $C_{IN}$  has adequate charge storage and very low ESR at the switching frequency. Other losses including diode conduction losses during dead-time and inductor core losses generally account for less than 2% total additional loss.

### Thermal Considerations

In a majority of applications, the LTC3407A-2 does not dissipate much heat due to its high efficiency. However, in applications where the LTC3407A-2 is running at high ambient temperature with low supply voltage and high duty cycles, such as in dropout, the heat dissipated may exceed the maximum junction temperature of the part. If the junction temperature reaches approximately 150°C, both power switches will be turned off and the SW node will become high impedance.

To prevent the LTC3407A-2 from exceeding the maximum junction temperature, the user will need to do some thermal analysis. The goal of the thermal analysis is to determine whether the power dissipated exceeds the maximum junction temperature of the part. The temperature rise is given by:

$$T_{RISE} = P_D \cdot \theta_{JA}$$

where  $P_D$  is the power dissipated by the regulator and  $\theta_{JA}$  is the thermal resistance from the junction of the die to the ambient temperature.

The junction temperature,  $T_J$ , is given by:

$$T_J = T_{RISE} + T_{AMBIENT}$$

As an example, consider the case when the LTC3407A-2 is in dropout on both channels at an input voltage of 2.7V with a load current of 800mA and an ambient temperature of 70°C. From the Typical Performance Characteristics graph of Switch Resistance, the  $R_{DS(ON)}$  resistance of the main switch is 0.425Ω. Therefore, power dissipated by each channel is:

$$P_D = I^2 \cdot R_{DS(ON)} = 272\text{mW}$$

The MS package junction-to-ambient thermal resistance,  $\theta_{JA}$ , is 45°C/W. Therefore, the junction temperature of the regulator operating in a 70°C ambient temperature is approximately:

$$T_J = 2 \cdot 0.272 \cdot 45 + 70 = 94.5^\circ\text{C}$$

which is below the absolute maximum junction temperature of 125°C.

### Design Example

As a design example, consider using the LTC3407A-2 in a portable application with a Li-Ion battery. The battery provides a  $V_{IN} = 2.8\text{V}$  to 4.2V. The load requires a maximum of 800mA in active mode and 2mA in standby mode. The output voltage is  $V_{OUT} = 2.5\text{V}$ . Since the load still needs power in standby, Burst Mode operation is selected for good low load efficiency.

First, calculate the inductor value for about 30% ripple current at maximum  $V_{IN}$ :

$$L = \frac{2.5\text{V}}{2.25\text{MHz} \cdot 360\text{mA}} \cdot \left(1 - \frac{2.5\text{V}}{4.2\text{V}}\right) = 1.25\mu\text{H}$$

## APPLICATIONS INFORMATION

Choosing the next highest standardized inductor value of 2.2 $\mu$ H, results in a maximum ripple current of:

$$\Delta I_L = \frac{2.5V}{2.25MHz \cdot 2.2\mu H} \cdot \left(1 - \frac{2.5V}{4.2V}\right) = 204mA$$

For cost reasons, a ceramic capacitor will be used.  $C_{OUT}$  selection is then based on load step droop instead of ESR requirements. For a 5% output droop:

$$C_{OUT} \approx 2.5 \frac{800mA}{2.25MHz \cdot (5\% \cdot 2.5V)} = 7.1\mu F$$

The closest standard value is 10 $\mu$ F. Since the output impedance of a Li-Ion battery is very low,  $C_{IN}$  is typically 10 $\mu$ F.

The output voltage can now be programmed by choosing the values of R1 and R2. To maintain high efficiency, the current in these resistors should be kept small. Choosing 2 $\mu$ A with the 0.6V feedback voltage makes R1 ~300k. A close standard 1% resistor is 280k, and R2 is then 887k.

The  $\overline{POR}$  pin is a common drain output and requires a pull-up resistor. A 100k resistor is used for adequate speed.

Figure 3 shows the complete schematic for this design example. The specific passive components chosen allow for a 1mm height power supply that maintains a high efficiency across load.

### Board Layout Considerations

When laying out the printed circuit board, the following checklist should be used to ensure proper operation of the

LTC3407A-2. These items are also illustrated graphically in the layout diagram of Figure 2. Check the following in your layout:

1. Does the capacitor  $C_{IN}$  connect to the power  $V_{IN}$  (Pin 3) and GND (exposed pad) as closely as possible? This capacitor provides the AC current to the internal power MOSFETs and their drivers.
2. Are  $C_{OUT}$  and L1 closely connected? The (-) plate of  $C_{OUT}$  returns current to GND and the (-) plate of  $C_{IN}$ .
3. The resistor divider formed by R1 and R2 must be connected between the (+) plate of  $C_{OUT}$  and a ground sense line terminated near GND (exposed pad). The feedback signals  $V_{FB1}$  and  $V_{FB2}$  should be routed away from noisy components and traces, such as the SW lines (Pins 4 and 7), and their traces should be minimized.
4. Keep sensitive components away from the SW pins. The input capacitor  $C_{IN}$  and the resistors R1 to R4 should be routed away from the SW traces and the inductors.
5. A ground plane is preferred, but if not available keep the signal and power grounds segregated with small signal components returning to the GND pin at one point. Additionally the two grounds should not share the high current paths of  $C_{IN}$  or  $C_{OUT}$ .
6. Flood all unused areas on all layers with copper. Flooding with copper will reduce the temperature rise of power components. These copper areas should be connected to  $V_{IN}$  or GND.

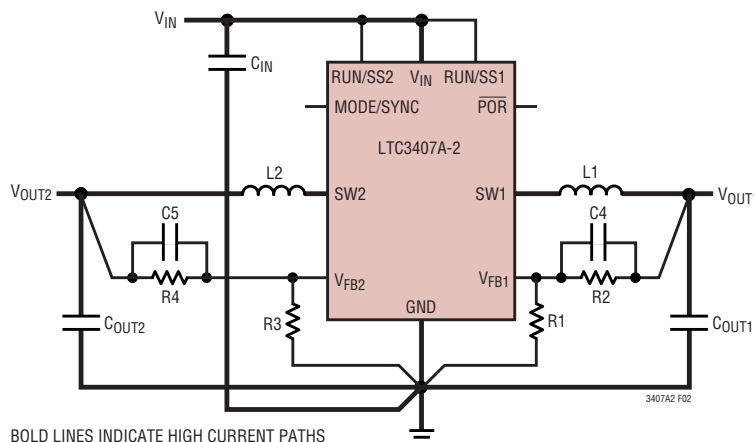

Figure 2. LTC3407A-2 Layout Diagram (See Board Layout Checklist)

TYPICAL APPLICATIONS

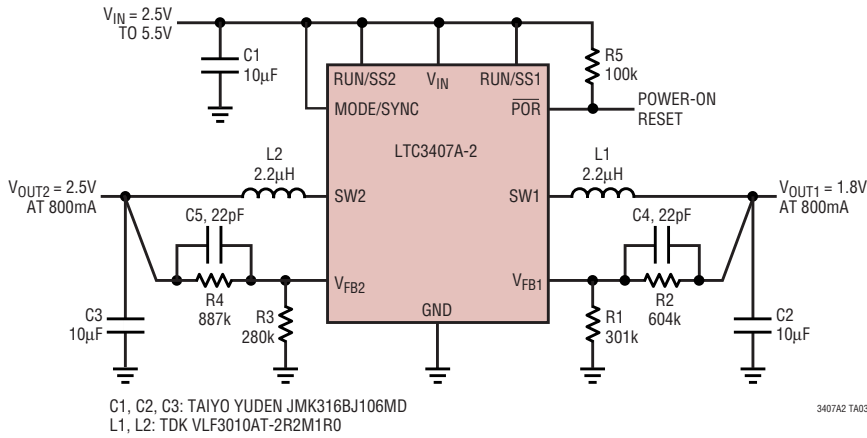

Figure 3. 1mm Height Core Supply

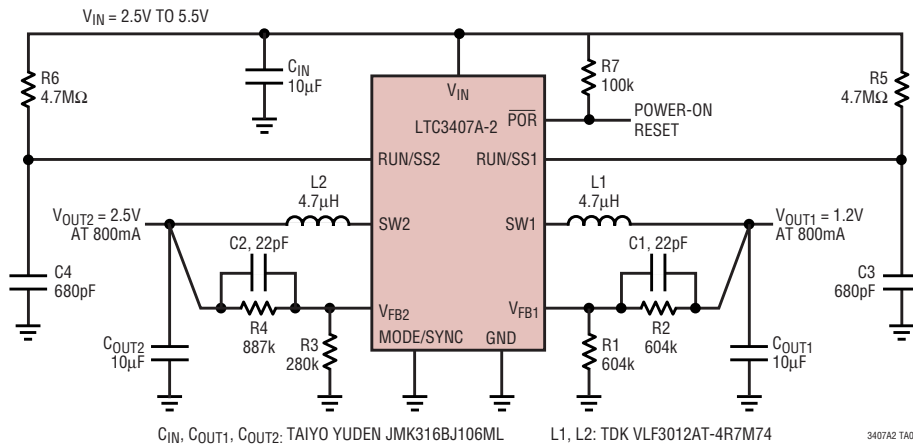
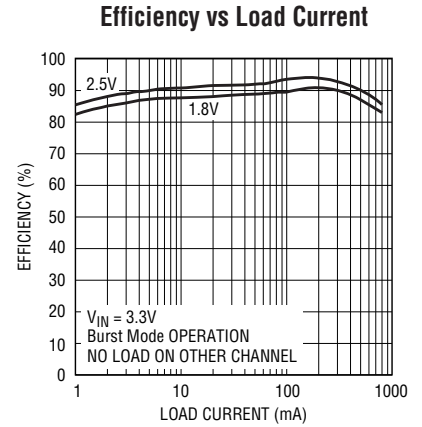
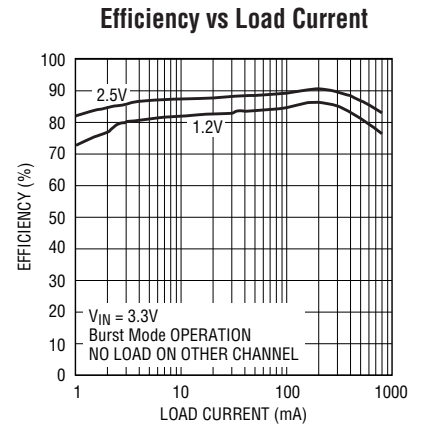
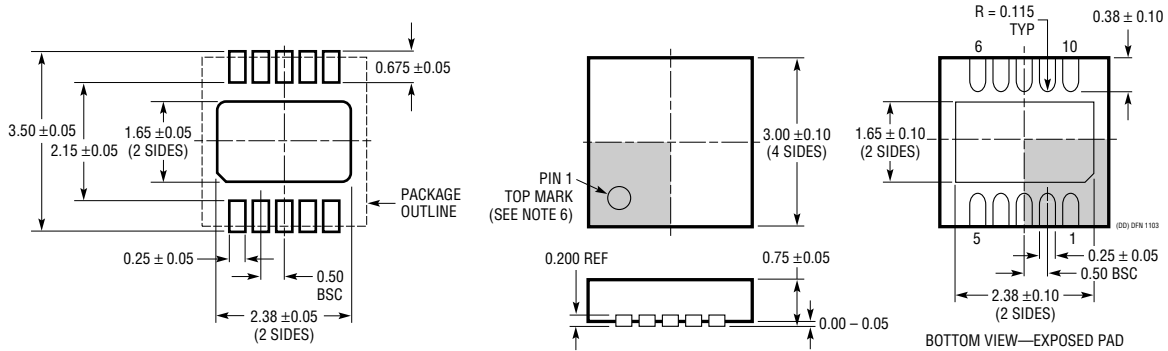

Figure 4. Low Ripple Buck Regulators with Soft-Start



# PACKAGE DESCRIPTION

## DD Package 10-Lead Plastic DFN (3mm × 3mm) (Reference LTC DWG # 05-08-1699)



### RECOMMENDED SOLDER PAD PITCH AND DIMENSIONS

- NOTE:
- DRAWING TO BE MADE A JEDEC PACKAGE OUTLINE MO-229 VARIATION OF (WEED-2). CHECK THE LTC WEBSITE DATA SHEET FOR CURRENT STATUS OF VARIATION ASSIGNMENT
  - DRAWING NOT TO SCALE
  - ALL DIMENSIONS ARE IN MILLIMETERS
  - DIMENSIONS OF EXPOSED PAD ON BOTTOM OF PACKAGE DO NOT INCLUDE MOLD FLASH. MOLD FLASH, IF PRESENT, SHALL NOT EXCEED 0.15mm ON ANY SIDE
  - EXPOSED PAD SHALL BE SOLDER PLATED
  - SHADED AREA IS ONLY A REFERENCE FOR PIN 1 LOCATION ON THE TOP AND BOTTOM OF PACKAGE

## MSE Package 10-Lead Plastic MSOP (Reference LTC DWG # 05-08-1664)

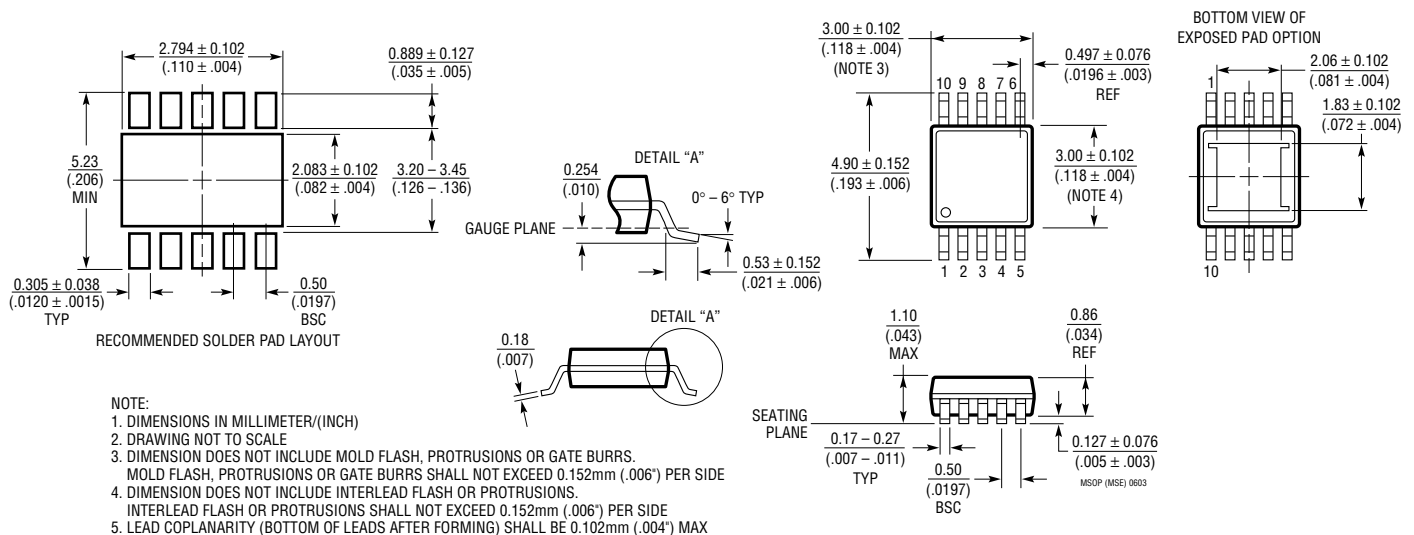

- NOTE:
- DIMENSIONS IN MILLIMETER/(INCH)
  - DRAWING NOT TO SCALE
  - DIMENSION DOES NOT INCLUDE MOLD FLASH, PROTRUSIONS OR GATE BURRS. MOLD FLASH, PROTRUSIONS OR GATE BURRS SHALL NOT EXCEED 0.152mm (.006") PER SIDE
  - DIMENSION DOES NOT INCLUDE INTERLEAD FLASH OR PROTRUSIONS. INTERLEAD FLASH OR PROTRUSIONS SHALL NOT EXCEED 0.152mm (.006") PER SIDE
  - LEAD COPLANARITY (BOTTOM OF LEADS AFTER FORMING) SHALL BE 0.102mm (.004") MAX

# TYPICAL APPLICATION

## 2mm Height Lithium-Ion Single Inductor Buck-Boost Regulator and a Buck Regulator

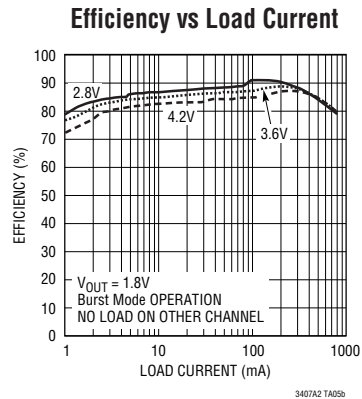
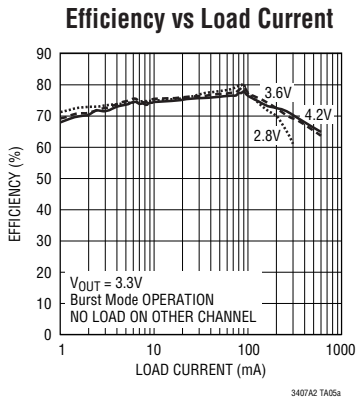
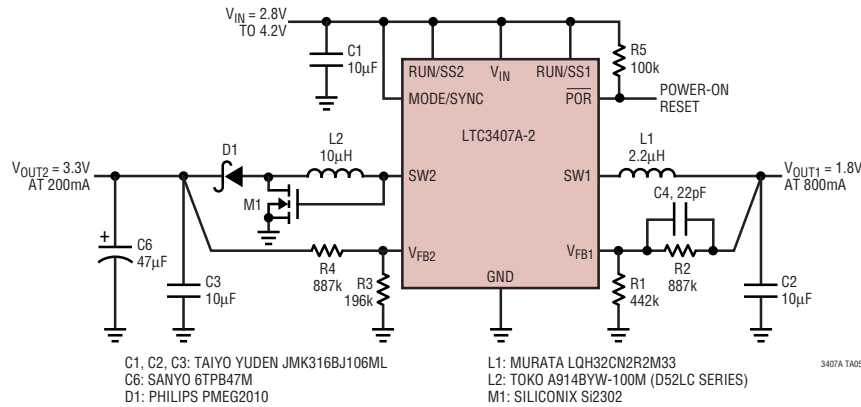

# RELATED PARTS

PART NUMBER	DESCRIPTION	COMMENTS
LTC3405/LTC3405A	300mA ( $I_{OUT}$ ), 1.5MHz, Synchronous Step-Down DC/DC Converter	96% Efficiency, $V_{IN}$ : 2.5V to 5.5V, $V_{OUT(MIN)} = 0.8V$ , $I_Q = 20\mu A$ , $I_{SD} < 1\mu A$ , ThinSOT Package
LTC3406/LTC3406B	600mA ( $I_{OUT}$ ), 1.5MHz, Synchronous Step-Down DC/DC Converter	96% Efficiency, $V_{IN}$ : 2.5V to 5.5V, $V_{OUT(MIN)} = 0.6V$ , $I_Q = 20\mu A$ , $I_{SD} < 1\mu A$ , ThinSOT Package
LTC3407/LTC3407-2 LTC3407-3/LTC3407-4/ LTC3407A	600mA/800mA ( $I_{OUT}$ ), 1.5MHz/2.25MHz, Dual Synchronous Step-Down DC/DC Converter	96% Efficiency, $V_{IN}$ : 2.5V to 5.5V, $V_{OUT(MIN)} = 0.6V$ , $I_Q = 40\mu A$ , $I_{SD} < 1\mu A$ , MS10E Package, DFN Package
LTC3410/LTC3410B	300mA ( $I_{OUT}$ ), 2.25MHz, Synchronous Step-Down DC/DC Converter in SC70	96% Efficiency, $V_{IN}$ : 2.5V to 5.5V, $V_{OUT(MIN)} = 0.8V$ , $I_Q = 26\mu A$ , $I_{SD} < 1\mu A$ , SC70 Package
LTC3411	1.25A ( $I_{OUT}$ ), 4MHz, Synchronous Step-Down DC/DC Converter	95% Efficiency, $V_{IN}$ : 2.5V to 5.5V, $V_{OUT(MIN)} = 0.8V$ , $I_Q = 60\mu A$ , $I_{SD} < 1\mu A$ , MSOP-10 Package
LTC3412/LTC3412A	2.5A ( $I_{OUT}$ ), 4MHz, Synchronous Step-Down DC/DC Converter	95% Efficiency, $V_{IN}$ : 2.5V to 5.5V, $V_{OUT(MIN)} = 0.8V$ , $I_Q = 60\mu A$ , $I_{SD} < 1\mu A$ , TSSOP-16E Package
LTC3414	4A ( $I_{OUT}$ ), 4MHz, Synchronous Step-Down DC/DC Converter	95% Efficiency, $V_{IN}$ : 2.25V to 5.5V, $V_{OUT(MIN)} = 0.8V$ , $I_Q = 64\mu A$ , $I_{SD} < 1\mu A$ , TSSOP-28E Package
LTC3440/LTC3441	600mA/1.2A ( $I_{OUT}$ ), 2MHz/1MHz, Synchronous Buck-Boost DC/DC Converter	95% Efficiency, $V_{IN}$ : 2.5V to 5.5V, $V_{OUT(MIN)} = 2.5V$ , $I_Q = 25\mu A$ , $I_{SD} < 1\mu A$ , MSOP-10 Package/DFN Package
LTC3548/ LTC3548-1/LTC3548-2	400mA/800mA ( $I_{OUT}$ ), 2.25MHz, Dual Synchronous Step-Down DC/DC Converter	95% Efficiency, $V_{IN}$ : 2.5V to 5.5V, $V_{OUT(MIN)} = 0.6V$ , $I_Q = 40\mu A$ , $I_{SD} < 1\mu A$ , MS10E Package/DFN Package