

Low Voltage Adjustable Precision Shunt Regulator

Features

- Wide Programmable Precise Output Voltage from 1.24V to 18V
- High Stability under Capacitive Load
- Low Temperature Deviation: 3mV Typical
- Low Equivalent Full-Range Temperature Coefficient: 20PPM/°C Typical
- Low Dynamic Output Resistance: 0.05Ω Typical
- High Sink Current Capacity from 55μA to 100 mA
- Low Output Noise
- Wide Operating Range of -40 to 125°C
- Available in RoHS Compliant, Lead Free Packaging

M1 Package
(SOT-89)

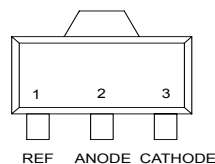

Applications

- Graphics Card
- PC Motherboard
- Voltage Adapter
- Switching Power Supply
- Charger

General Description

The SPX431LJ series ICs are low voltage three-terminal adjustable regulators with guaranteed thermal stability over a full operation range. These ICs feature sharp turn-on characteristics, low temperature coefficient and low output impedance, which make them ideal substitutes for Zener diodes in applications such as switching power supply, charger, motherboard and other adjustable regulators. The output voltage can be set to any value between 1.24V and 18V with two external resistors. The SPX431LJ precision reference is offered in two bandgap tolerances: 0.5% and 1%. These ICs are available in TO-92 and SOT-89 packages.

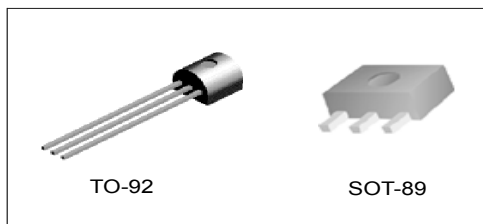

Figure 1. Package Types of SPX431LJ

Pin Configuration

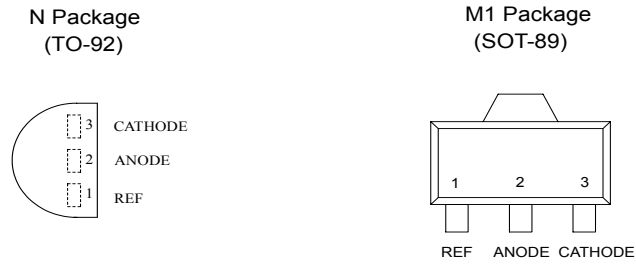

Figure 2. Pin Configuration of SPX431LJ (Top View)

Functional Block Diagram

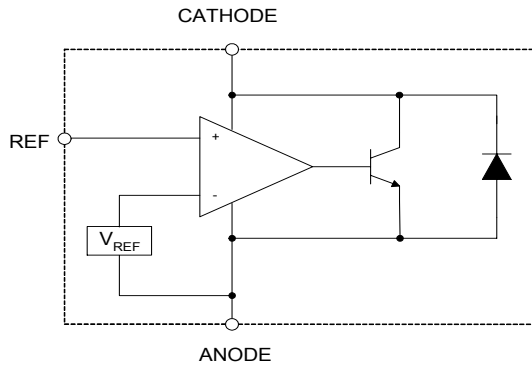

Figure 3. Functional Block Diagram of SPX431LJ

Absolute Maximum Ratings (Note 1)

Parameter	Symbol	Value	Unit	
Cathode Voltage	V_{KA}	20	V	
Cathode Current Range (Continuous)	I_{KA}	-100 to 100	mA	
Reference Input Current Range	I_{REF}	10	mA	
Power Dissipation	P_D	TO-92, SOT-89 Package	770	mW
Storage Temperature Range	T_{STG}	-65 to 150	°C	
Package Thermal Impedance	Q_{JA}	TO-92	130	°C/W
		SOT-89	100	

Note 1: Stresses greater than those listed under "Absolute Maximum Ratings" may cause permanent damage to the device. These are stress ratings only, and functional operation of the device at these or any other conditions beyond those indicated under "Recommended Operating Conditions" is not implied. Exposure to "Absolute Maximum Ratings" for extended periods may affect device reliability.

Recommended Operating Conditions

Parameter	Symbol	Min	Max	Unit
Cathode Voltage	V_{KA}	V_{REF}	18	V
Cathode Current	I_{KA}	0.1	100	mA
Operating Ambient Temperature Range		-40	125	°C

Electrical Characteristics

(Typical and limits apply for $T_J=25^\circ\text{C}$ unless otherwise noted.)

Parameter	Test Circuit	Symbol	Conditions	Min	Typ	Max	Unit
Reference Voltage	0.5%	V_{REF}	$V_{KA}=V_{REF}, I_{KA}=10\text{mA}$	1.234	1.240	1.246	V
	1%			1.228	1.240	1.252	
Deviation of Reference Voltage Over-Temperature	4	ΔV_{REF}	$V_{KA}=V_{REF}, I_{KA}=10\text{mA}$	0°C to 70°C	2	10	mV
				-40°C to 85°C	3	10	
Ratio of Change in V_{REF} to the Change in Cathode Voltage	5	$\frac{\Delta V_{REF}}{\Delta V_{KA}}$	$I_{KA}=10\text{mA}, \Delta V_{KA}: V_{REF}$ to 16V		-0.5	-1.5	mV/V
Reference Input Current	5	I_{REF}	$I_{KA}=10\text{mA}, R1=10\text{K}\Omega, R2=\infty$		0.15	0.4	μA
Deviation of Reference Current Over Full Temperature Range	5	ΔI_{REF}	$I_{KA}=10\text{mA}, R1=10\text{K}\Omega, R2=\infty, T_A=-40$ to 85°C		0.1	0.4	μA
Minimum Cathode Current for Regulation	4	I_{KA} (MIN)	$V_{KA}=V_{REF}$		55	80	μA
Off-State Cathode Current	6	I_{KA} (OFF)	$V_{REF}=0, V_{KA}=18\text{V}$		0.04	0.10	μA
			$V_{KA}=6, V_{REF}=0$		0.01	0.05	
Dynamic Impedance	4	Z_{KA}	$V_{KA}=V_{REF}, I_{KA}=1$ to 100mA $f \leq 1.0\text{kHz}$		0.05	0.15	Ω

Electrical Characteristics (Continued)

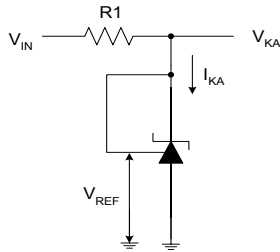

Figure 4. Test Circuit 4 for $V_{KA} = V_{REF}$

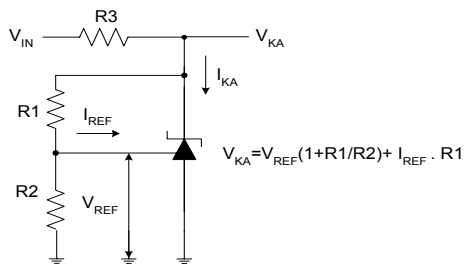

Figure 5. Test Circuit 5 for $V_{KA} > V_{REF}$

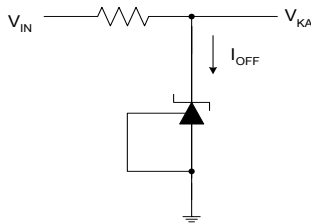

Figure 6. Test Circuit 6 for I_{OFF}

Typical Performance Characteristics

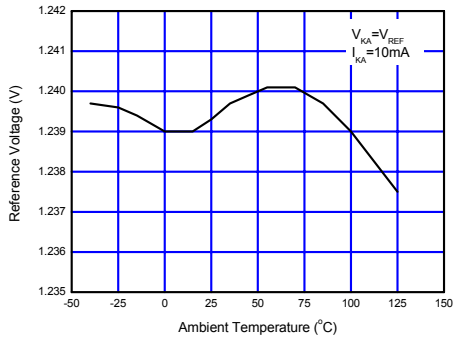

Figure 7. Reference Voltage vs. Ambient Temperature

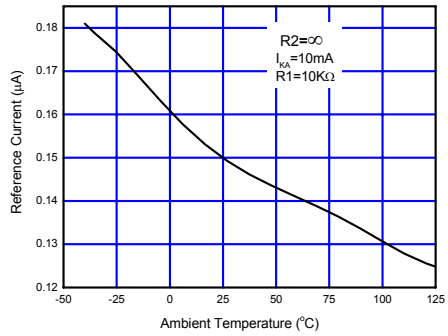

Figure 8. Reference Current vs. Ambient Temperature

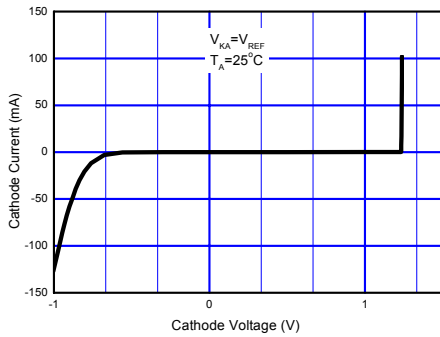

Figure 9. Cathode Current vs. Cathode Voltage

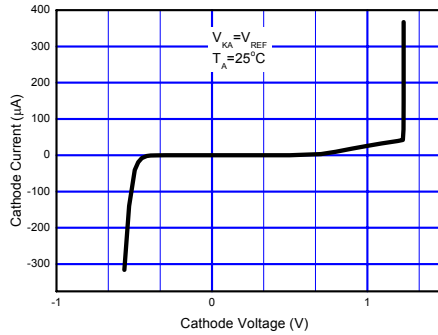

Figure 10. Current vs. Cathode Voltage

Typical Performance Characteristics (Continued)

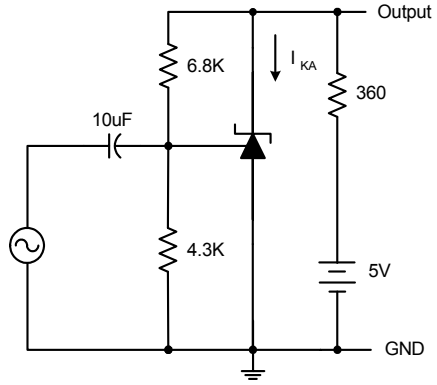
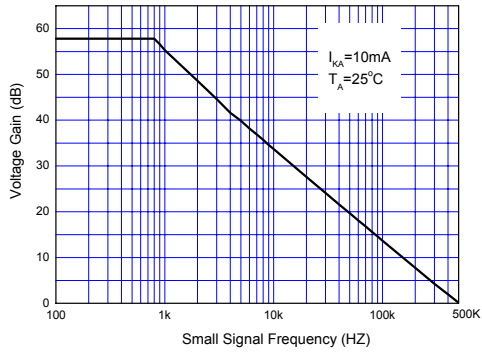

Figure 11. Small Signal Voltage Gain vs. Frequency

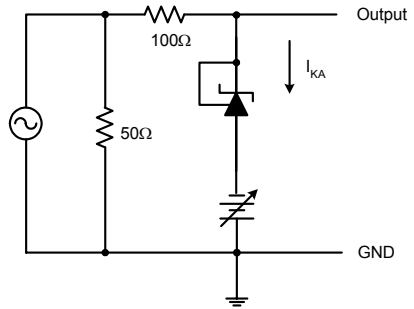
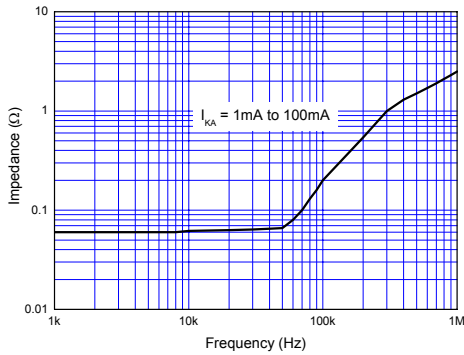

Figure 12. Dynamic Impedance vs. Frequency

Typical Performance Characteristics (Continued)

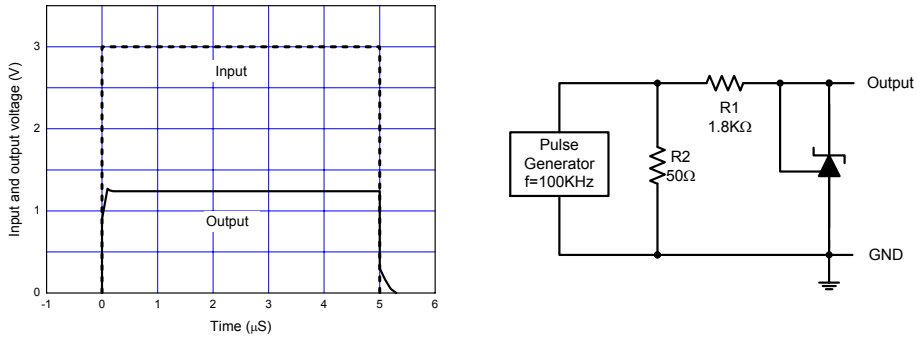

Figure 13. Pulse Response of Input and Output Voltage

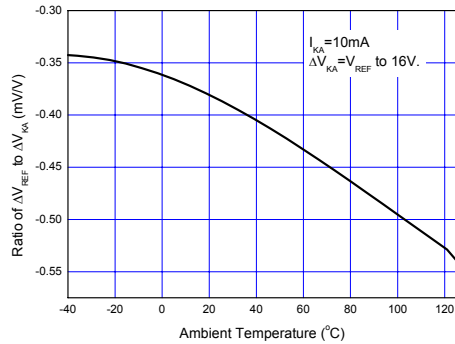

Figure 14. Ratio of Delta Reference Voltage to the Ratio of Cathode Voltage vs. Ambient Temperature

Typical Applications

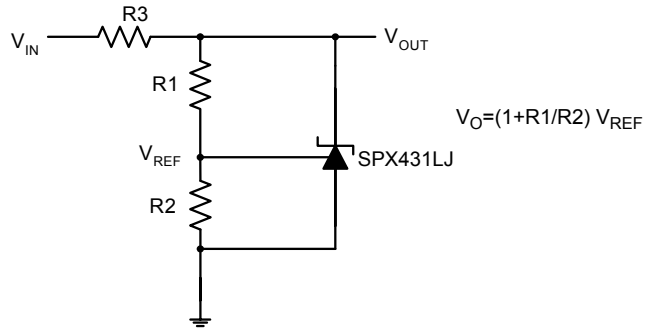

Figure 15. Shunt Regulator

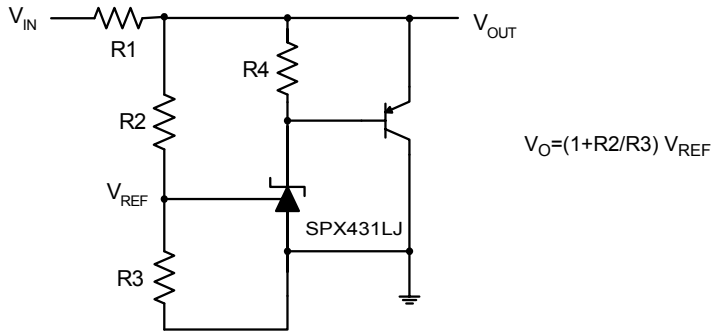

Figure 16. High Current Shunt Regulator

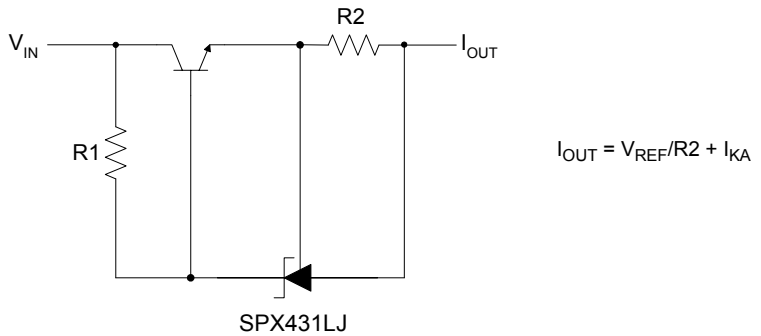

Figure 17. Current Source or Current Limit

Typical Application (Continued)

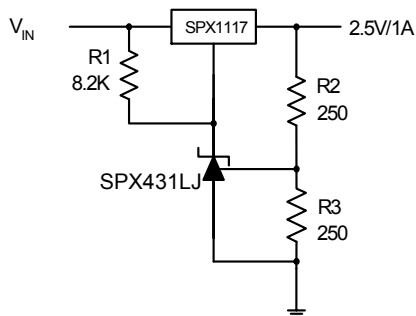

Figure18. Precision 2.5-V 1A Regulator

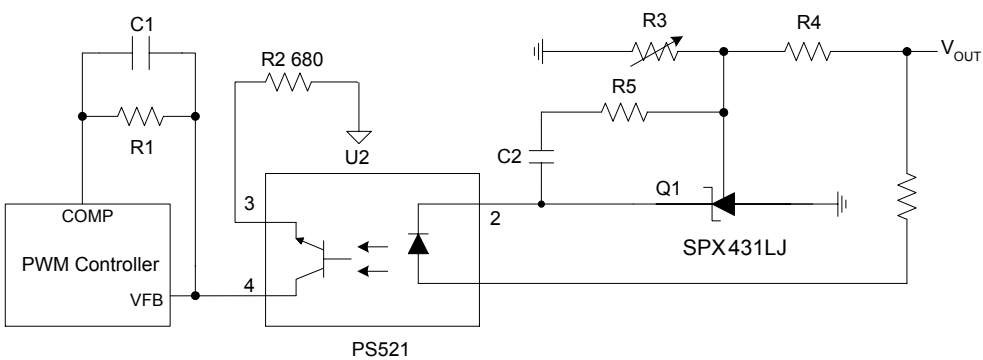
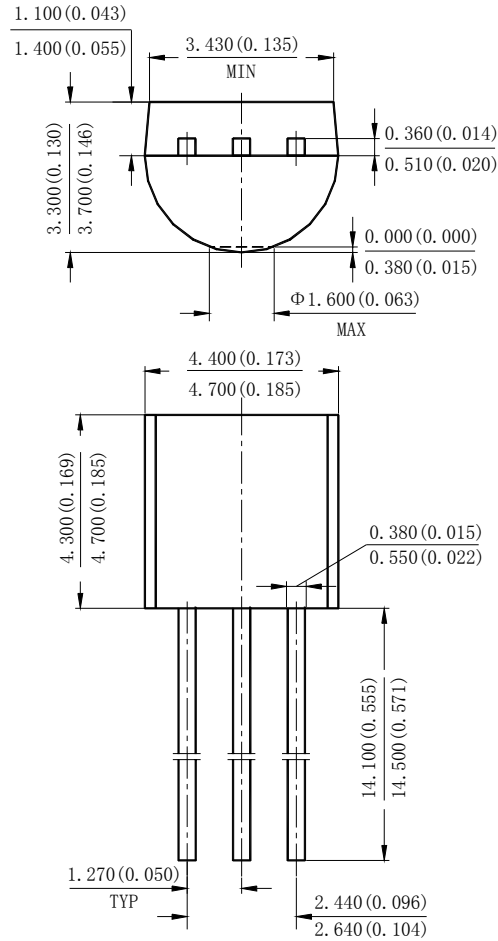

Figure 19. PWM Converter with Reference

Mechanical Dimensions

TO-92

Unit: mm (inch)



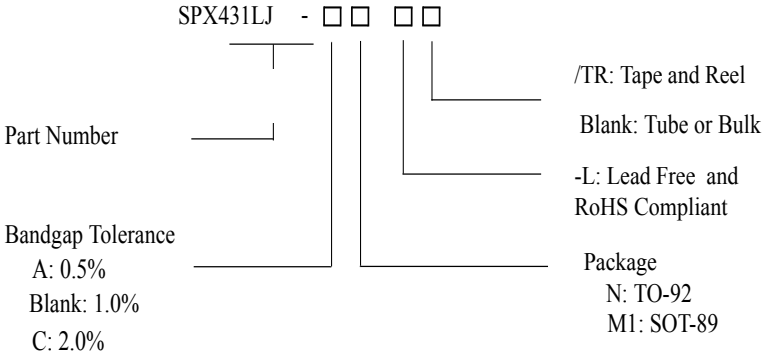

Part Number	Temperature Range	Voltage Tolerance	Output Voltage	Package	Pin Count	Packing Type
SPX431LJAM1-L/TR	-40°C to +125°C	0.5%	Adj	SOT-89	3	1,000/TR
SPX431LJM1-L/TR	-40°C to +125°C	1.0%	Adj	SOT-89	3	1,000/TR
SPX431LJCM1-L/TR	-40°C to +125°C	2.0%	Adj	SOT-89	3	1,000/TR
SPX431LJAN-L/TR	-40°C to +125°C	0.5%	Adj	TO-92	3	2,000/AMMO
SPX431LJN-L/TR	-40°C to +125°C	1.0%	Adj	TO-92	3	2,000/AMMO
SPX431LJCN-L/TR	-40°C to +125°C	2.0%	Adj	TO-92	3	2,000/AMMO



Sipex Corporation
 Headquarters and Sales Office
 233 South Hillview Drive
 Milpitas, CA 95035
 TEL: (408) 934-7500
 FAX: (408) 935-7600

Sipex Corporation reserves the right to make changes to any products described herein. Sipex does not assume any liability arising out of the application or use of any product or circuit described herein; neither does it convey any license under its patent rights nor the rights of others.