

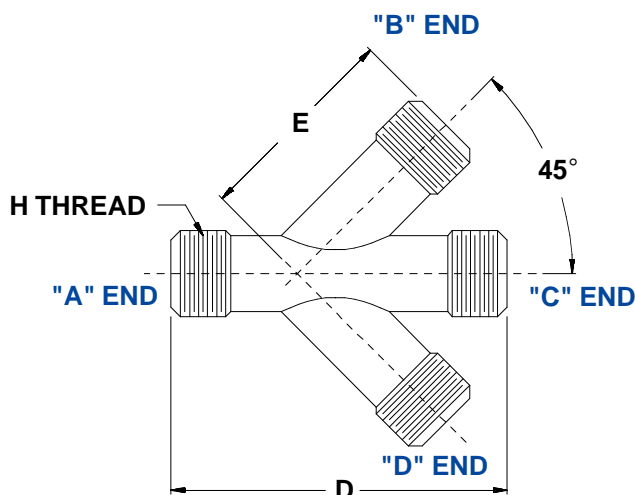
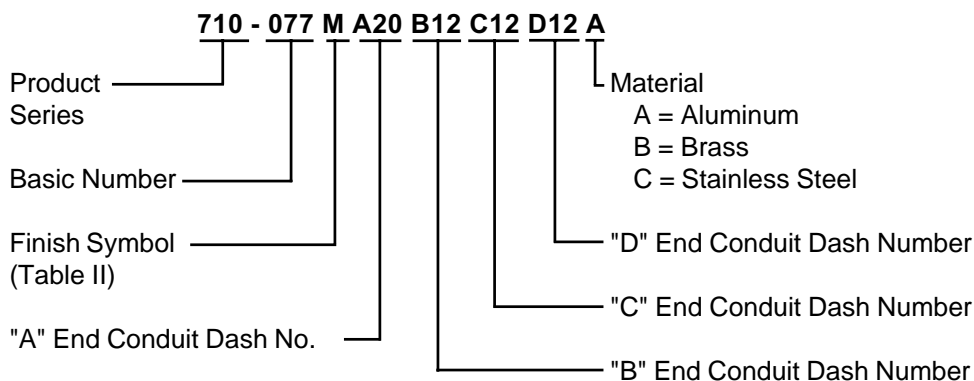

## 710-077 Metal Multi-Branch Transitions for Series 72 & 74 Tubing and Series 75 Conduit

**TABLE I**

DASH NO.	AVAILABILITY			H THREAD CLASS 2A	D MAX	E MAX
	72	74	75			
06		06		7/16 - 28 UNEF	1.97 (50.0)	1.20 (30.5)
08			08	1/2 - 20 UNF	1.97 (50.0)	1.20 (30.5)
09		09	09	9/16 - 24 UNEF	2.13 (54.1)	1.30 (33.0)
10		10		9/16 - 24 UNEF	2.13 (54.1)	1.30 (33.0)
12	12	12	12	5/8 - 24 UNEF	2.22 (56.4)	1.34 (34.0)
14		14		11/16 - 24 UNEF	2.37 (60.2)	1.49 (37.8)
16	16	16	16	3/4 - 20 UNEF	2.37 (60.2)	1.49 (37.8)
20	20	20	20	7/8 - 20 UNEF	2.69 (68.3)	1.70 (43.2)
24	24	24	24	1 - 20 UNEF	2.75 (69.9)	1.84 (46.7)
28	28	28		1 3/16 - 18 UNEF	3.06 (77.7)	2.09 (53.1)
32	32	32	32	1 5/16 - 18 UNEF	3.28 (83.3)	2.23 (56.6)
40	40	40	40	1 1/2 - 18 UNEF	3.59 (91.2)	2.50 (63.5)
48		48	48	1 3/4 - 18 UNS	4.23 (107.4)	2.96 (75.2)
56		56	56	2 - 18 UNS	5.00 (127.0)	3.50 (88.9)
64		64	64	2 1/4 - 16 UN	5.00 (127.0)	3.50 (88.9)
80			80	2 3/4 - 16 UN	5.70 (144.8)	4.10 (104.1)
*						

Consult factory for fittings using 3.00 inch (76.2) conduit.

**TABLE II**

SYMBOL	FINISH
B	Olive Drab over Cadmium Plate
J	Gold Iridite over Cadmium Plate over Nickel
M	Electroless Nickel
N	Olive Drab over Cadmium Plate over Nickel
NC	Zinc Cobalt, Olive Drab
NF	Olive Drab over Cadmium Plate over Electroless Nickel (500 Hour Salt Spray)
T	Bright Dip Cadmium Plate over Nickel
Z1	Passivate

Metric dimensions (mm) are in parentheses.