



**80W POWER-FACTOR-CORRECTED AC-DC ADAPTER
WITH STANDBY USING THE L6561 AND THE L5991A**

by C. Adragna

This note describes an 80 W, wide-range mains, power-factor-corrected AC-DC adapter. Its electrical specification is tailored on a typical hi-end portable computer power adapter. The peculiarity of this design is its extremely low no-load input consumption (<1 W).

The architecture is based on a two-stage approach: a front-end PFC pre-regulator based on the L6561 TM PFC controller and a back-end DC-DC converter in flyback topology that makes use of the L5991A PWM controller. The Standby function of the L5991A, which reduces the switching frequency of the DC-DC converter upon recognition of a light load, is also used to turn off the PFC stage to make it possible meeting the severe no-load consumption requirement.

Design Specification

The design of an 80W power-factor-corrected AC-DC adapter suitable for hi-end portable computer and the evaluation results of a prototype are here described.

Table 1 shows the electrical specification of the application, table 2 provides the BOM and tables 3 and 4 list magnetics' spec. The electrical schematic is illustrated in figure 1 and the PCB layout in figure 2.

Table 1. 80W AC-DC adapter with PFC and Standby: electrical specification

Input Voltage Range (V_{in})	90 to 265 Vac
Mains Frequency (f_L)	50/60 Hz
Holdup time	20 ms
Maximum Output Power (P_{Outmax})	80 W
Output	$V_{out} = 18 \text{ Vdc} \pm 2\%$ $I_{out} = 0 \text{ to } 4.5 \text{ A}$ $V_{ripple} = 1\%$
Line and Load regulation	< 1%
Switching Frequency (Flyback, @ $P_{Out} = 80 \text{ W}$)	65 kHz
Switching Frequency (Flyback, @ $P_{Out} = 0 \text{ W}$)	22 kHz
PFC Minimum Switching Frequency (@ $P_{Out} = 80 \text{ W}$)	35 kHz
PFC Output Voltage	400 Vdc $\pm 5\%$
PFC Output Voltage ripple (@ $f_L = 50 \text{ Hz}$, full load)	<20 V pk-pk
PFC Output Overvoltage threshold	440 Vdc
Overall Efficiency (@ $P_{Out} = 80 \text{ W}$, $V_{in} = 90\div 265 \text{ Vac}$)	$\eta > 75\%$
Maximum No-load Input Power	< 1 W
Low-frequency harmonic contents	EN 61000-3-2, class D compliant
Conducted EMI	EN 55022, class B compliant

AN1440 APPLICATION NOTE

To meet the requirement on low-frequency emission, active power factor correction will be used, resulting in a two-stage architecture: a front-end PFC pre-regulator, using boost topology, followed by a cascaded DC-DC converter. As to the PFC stage, the power rating suggests the use of TM operation, and then the L6561 [1] will be used as the controller. The cascaded DC-DC converter will use flyback topology: the high input voltage (400V, output of the PFC stage) and the relatively high output voltage make this topology the most attractive for this application.

A special requirement concerns the no-load consumption from the mains: less than 1 W. Especially in a two-stage system, this is a tough job. Special design care needs to be taken, from both the system and the selection of the PWM controller point of view.

Figure 1. 80W AC-DC adapter with PFC and Standby: electrical schematic

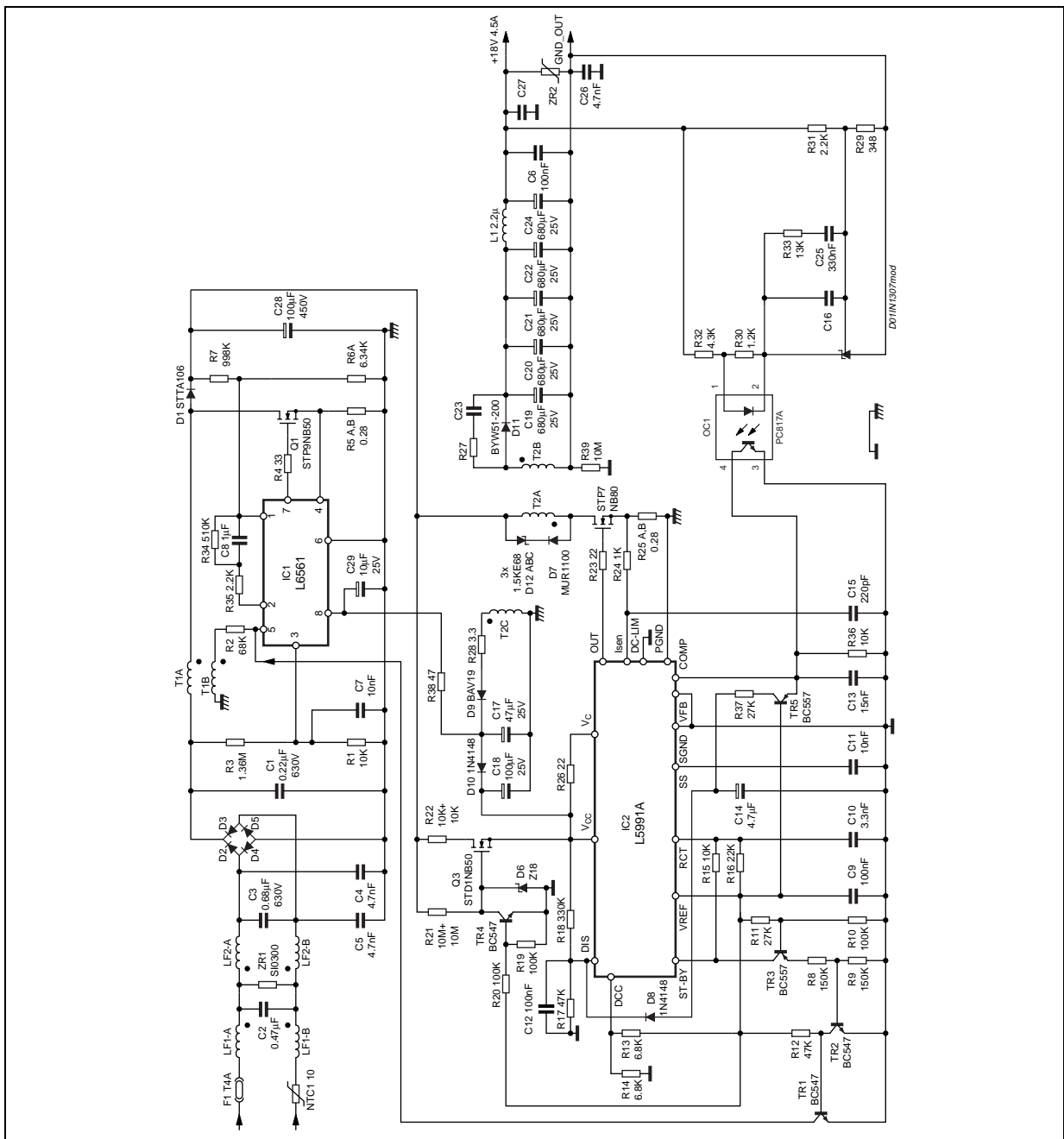

Table 2. 80W AC-DC adapter with PFC and Standby: Bill Of Material

Symbol	Value	Note
R1, R15, R36	10 k Ω	
R2	68 k Ω	
R3A, R3B	680 k Ω	
R4	33 Ω	
R5A, R5B, R25A, R25B	0.56 Ω	1W, metal film
R6A	6.34 k Ω	Only R6A assembled. R6B is for Fine-Tuning
R7A, R7B	499 k Ω	
R8, R9	150 k Ω	
R10, R19, R20	100 k Ω	
R11, R37	27 k Ω	
R12, R17	47 k Ω	
R13, R14	6.8 k Ω	
R16	20 k Ω	
R18	330 k Ω	
R21A, R21B	10 M Ω	
R22A, R22B	10 k Ω	$\frac{1}{2}$ W
R23, R26	22 Ω	
R24	1 k Ω	
R27	---	Not assembled
R28	3.3 Ω	
R29	348 Ω	
R30	1.2 k Ω	
R31, R35	2.2 k Ω	
R32	4.3 k Ω	
R33	13 k Ω	
R34	510 k Ω	
R38	47 Ω	
R39	10 M Ω	$\frac{1}{2}$ W, VR37
C1	0.22 μ F	630V, polyester
C2	0.47 μ F	275 AVC, X2
C3	0.68 μ F	630V, polyester
C4, C5, C26	4.7 nF	Ceramic, Y
C6	0.1 μ F	Polyester
C7, C11	10 nF	
C8	1 μ F	
C9, C12	100 nF	Ceramic
C10	3.3 nF	5%

AN1440 APPLICATION NOTE

Table 2. 80W AC-DC adapter with PFC and Standby: Bill Of Material (continued)

Symbol	Value	Note
C13	15 nF	
C14	4.7 μ F	16 V, electrolytic
C15	220 pF	
C16, C23, C27	---	Not assembled
C17	47 μ F	25 V, electrolytic
C18	100 μ F	25 V, electrolytic
C19, C20, C21, C22, C24	680 μ F	25V Rubycon, ZL series
C25	330 nF	
C28	100 μ F	450 V, electrolytic, EPCOS B43502
C29	10 μ F	25 V, electrolytic
D1	STTA106	600 V / 1 A, Turboswitch, ST
D2, D3, D4, D5	KBP208M	800 V / 2 A Bridge rectifier, or equivalent
D6	1N5248B	18V, ½ W Zener, or equivalent
D7	MUR1100E	1100 V / 1 A, Ultrafast
D8, D10	1N4148	75 V / 0.3 A p-n diode, or equivalent
D9	BAV19	100 V / 0.25 A p-n diode, or equivalent
D11	BYW51-200	200 V / 2x10 A Ultrafast, ST
D12A, D12B, D12C	1.5KE68	1.5 kW / 68 V Transil, ST
L1	ELC08D2R2E	2.2 μ H / 7.2A inductor, Panasonic, or equivalent
LF1	B82732	15 mH / 1.1 A EPCOS
LF2	B82734	47 mH / 1.3 A, EPCOS
TR1, TR2, TR4	BC547	Small-signal NPN
TR3, TR5	BC557	Small-signal PNP
Q1	STP9NB50	500 V / 9A MOSFET, ST
Q2	STP7NB80	800 V / 7A MOSFET, ST
Q3	STD1NB50	500V / 1A MOSFET, ST
IC1	L6561	PFC TM controller, ST
IC2	L5991A	PWM controller, ST
OC1	PC817A	Optocoupler, SHARP
VR1	TL431C	Programmable shunt regulator, ST
NTC1	S236/10M	10 Ω NTC
T1	473201A8	PFC inductor (see table 3), OREGA
T2	RDT13560	Flyback transformer (see table 4), RD Elettronica
ZR1	S14K300	MOV, EPCOS, or equivalent
ZR2	---	Not assembled
F1	T4A	250V / 4A, ELU or equivalent

Notes: if not otherwise specified: all resistors are 1%, ¼ W, all capacitors may be plastic film or ceramic, 20% tolerance
Q1 is provided with a 25 °C/W heatsink, Q2 and D11 are provided with a 9.5°C/W heatsink

Table 3. 80W AC-DC adapter with PFC and Standby: PFC inductor spec (p.n. 473201A8)

Core	B1ET2910A, B1 Material from THOMSON				
Bobbin	Vertical mounting, 18 pins, slotted				
Air gap	≈ 1.25 mm on center leg for an inductance 2-7 of 430 μH				
Windings Spec & Build	Pin Start/End	Winding	Wire	Turns	Notes
	2/7	Pri	10 x AWG32	90	
	12/17	Aux	AWG32	7	

Table 4. 80W AC-DC adapter with PFC and Standby: Flyback transformer spec (p.n. RDT13560)

Core	E32/16/9, N67 Material or 3C85 or equivalent				
Bobbin	Horizontal mounting, 14 pins				
Air gap	≈ 1 mm on center leg for an inductance 10-9 of 430 μH				
Leakage inductance	< 10 μH (@ 65 kHz) measured between pins 10-9 with 3,5,12,13 shorted				
Windings Spec & Build	Pin Start/End	Winding	Wire	Turns	Notes
	10/1	Pri1	AWG26	28	Innermost winding
	3/5	Sec	4xAWG22	10	Separated from the primary windings by a 3-layer polyester isolation
	1/9	Pri2	AWG26	28	Pin 1 will be cut for safety
	12/13	Aux	AWG32	8	Evenly spaced, 2-layer isolation

As to the PWM controller, the choice is the L5991A [2]: above all else, its Standby function makes this device particularly suitable for building a "highly-efficient" converter under no-load conditions.

From the overall system point of view, a fundamental point is:

- Under no-load conditions the PFC pre-regulator must be shut down.

Then the optimization effort for low light-load losses will be concentrated on the flyback converter. Based on the advice given in [3], the following design choices have been made:

- Use of an active start-up circuit.
- Use of a Transil clamp to handle the leakage inductance spikes.

The critical point where maximum design effort needs to be put to optimize the performance is the design and the construction of the transformer. In particular the points to look at are:

- The primary to-secondary leakage inductance, which must be as low as possible, to minimize the energy dissipated in the clamp circuit so as to make it possible the use of a Transil clamp.
- The intrawinding capacitance of the primary winding, which must be as low as possible, to minimize the capacitive losses of the MOSFET.
- The coupling between the secondary and the auxiliary winding, which must be as good as possible, to minimize the drop of the auxiliary voltage (used for supplying the controllers) as the converter's load goes to zero. This is very important, since a stable self-supply circuit avoids the use of dummy loads that would increase no-load consumption.

To get 100 V reflected voltage, the primary-to-secondary turn ratio is made 1:5.6, which generates a reverse voltage across the secondary rectifier that may approach 100V if the output of the PFC stage gets close to its OVP threshold. To have enough safety margin, a 200V ultrafast rectifier needs to be used. A BYW51-200 has been selected.

To stay within the required tolerance, the output voltage regulation is done with secondary feedback, using a typical arrangement TL431+optocoupler. An LC cell is used as a post-filter to minimize high-frequency output ripple, then the feedback signal is taken upstream the cell to avoid introducing an extra phase-shift that may affect loop stability significantly. By using a low-resistance choke, the degradation of the load regulation will be kept to a minimum.

There is a full coverage of anomalous operating conditions. Overload and short circuit are handled following the approach suggested in [5], resulting in a latched shutdown of the converter by means of L5991A's Disable function. R37 and C14 determine how much the shutdown is delayed. Additionally, thanks to the 2nd overcurrent level on the L5991A's current sense pin, also a short circuit directly across the secondary winding - or even D11 failing short - will be safely handled: either failure will cause an intermittent operation ("Hiccup" mode) with a low level of power throughput. Finally, in case the optocoupler fails or R31 opens, the Disable function of the L5991A will be invoked (via the divider R17-R18), thus causing a latched shutdown.

Two basic design choices have been done to meet the no-load consumption target. First, instead of the usual dropping resistor, the converter is started with a circuit comprising an active switch that is ON only during start-up and then is switched off as the converter starts operating. This circuit has been designed so as to provide a maximum wake-up time of 0.2s @ 90 Vac and a consumption of less than 10 mW @ 265 Vac when the circuit is off.

Second, the leakage inductance spikes are handled by a Transil clamp instead of an RCD clamp, thus saving the power V_R^2/R that would be dissipated on the resistor during no-load conditions. This requires the transformer's leakage inductance to be as low as possible to limit full-load losses on the Transil. However, even with a transformer done to perfection, there is a limit to the leakage inductance reduction due to the need of fulfilling safety regulations. As a result, in the specific case, even with 1% leakage inductance the power dissipated in the Transil is so large that cannot be handled by a single device; therefore, three Transils (1.5KE68), series-connected, are used to share the loss.

At this point, a number of design considerations are needed concerning how the two stages live together and interact. These will have a lot of implications, mainly on the power-on/power-off sequence and then on the self-supply system of the two IC's.

As previously said, a fundamental step to meet the no-load consumption requirement is to shut down the PFC stage under no-load conditions. Experiments show that a completely unloaded PFC stage, if well optimized, draws from the mains slightly more than 0.5 W at high line, hence leaving no practical room to the consumption of the flyback stage. Disabling the PFC stage is then a must.

On the other hand, power factor correction is required at nominal load, then it is of no use keeping the PFC stage active when the load is significantly lower. Hence it is possible to disable the PFC stage when the L5991A goes into Standby mode reducing the switching frequency of the flyback stage.

The Standby mode can be detected by looking at pin 16 (S-BY) of the L5991A: while during normal operation the voltage at pin 16 is 5V, during Standby mode the pin is floating, thus its voltage follows that at pin 2 (RCT) and swings from 1 to 3 V.

Figure 3. 80W AC-DC adapter with PFC and Standby: L6561 ON/OFF via L5991A Standby mode

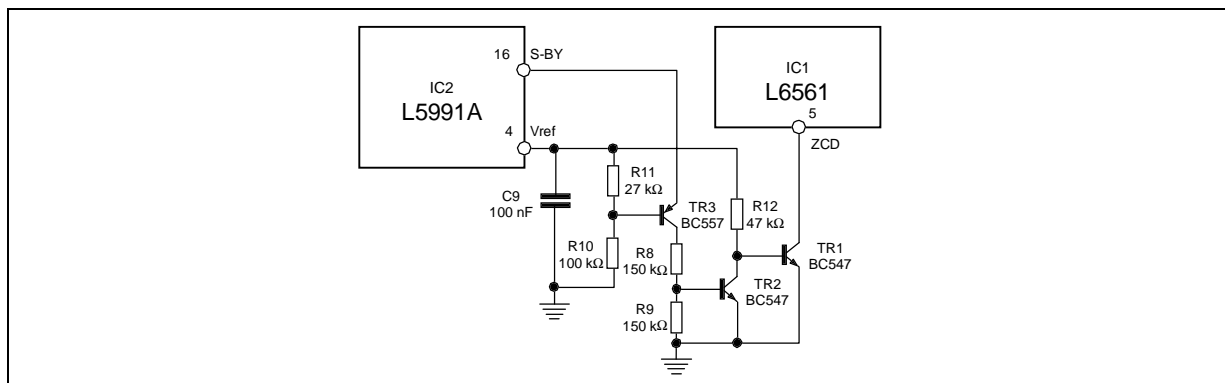

The circuit shown in figure 3 interfaces the L5991A and the L6561 and illustrates how the S-BY pin signal can be used. When the L5991A goes into Standby, the base of TR3 (tied at about 4 V) is reverse-biased: TR3 is cut off and so is TR2. TR1 is then turned on and pulls L6561's pin 5 (ZCD) to ground, thus disabling the PFC controller. This solution is insensitive to temperature variations and parameter spread, does not alter the oscillator frequency and absorbs a negligible power during Standby mode.

Special care is needed for the design of the self-supply circuit of both the L6561 and the L5991A. A solution with separate self-supply circuits has been discarded because the start-up sequence could not be definitely determined without using additional circuitry.

One more point to consider is that the supply voltage of the L6561 must be above its UVLO threshold at all times. Thus, when the L5991A goes from Standby mode back to normal mode following on a large load increase, it can start immediately to avoid any voltage dip on the converter's output.

Then, since the L6561 will be stopped during standby, the self-supply winding needs to be derived from the transformer of the flyback stage. The coupling of this winding with the secondary one is critical: because of not perfect coupling the voltage generated tends to increase at heavy load and to drop at light load. The tolerable change of this voltage is limited by the L6561: downward by its UVLO threshold (10.3 V) and upward by the internal zener on its Vcc pin (18 V). This is why the L5991A has been used instead of the L5991: the latter has a maximum UVLO threshold of 11V, which would narrow down the allowable Vcc range.

Using the flyback transformer to generate the self-supply requires the flyback stage to start first and the PFC pre-regulator to follow. The solution put to use is illustrated in figure 4.

Figure 4. 80W AC-DC adapter with PFC and Standby: self-supply circuit

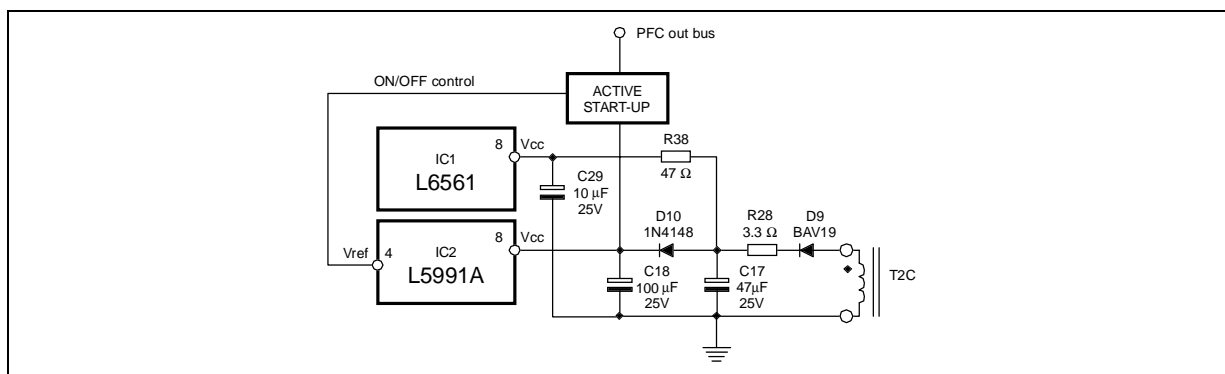

This system approach has a significant impact on the electrical design of the flyback stage. It will be designed for a steady-state Discontinuous Conduction Mode operation starting from a DC input of 400V, however the start-up phase cannot be neglected. The output voltage of the PFC stage takes some time to reach the final value (up to 80-90 ms at low line), thus a start-up @ 90 Vac input voltage, cold NTC and full load may require the flyback stage to work for

some time with just the rectified mains, as if it were a not power-factor-corrected wide-range-mains converter. In the end, at least from the electrical point of view, the flyback will be treated as a wide-range-input system: then the inductance of the transformer and its ΔB swing, as well as the sense resistor will be selected consequently. Also the maximum duty cycle allowed will be fixed at 70% (whereas the steady-state value is around 15%). From the thermal point of view, however, there is no need to consider the start-up, thus MOSFET's size, transformer's wire and clamp will be determined considering steady-state conditions.

Board evaluation: getting started

The AC voltage, generated by an AC source ranging from 90 Vac to 265 Vac, will be applied to the input connector (M1, next to the bottom left-hand corner) and the load will be tied to connector M2, at the top right-hand corner). If desired, the board can be supplied also by a high-voltage DC source, in which case the PFC pre-regulator will work just as a standard boost converter. The most interesting points to analyze are those concerning the interaction between the PFC pre-regulator and the flyback stage occurring every time the L5991A passes from normal operation to Standby and vice versa because of a load change. Then, besides the usual points (MOSFET's drain voltage, current sense signal, etc.), it is worth probing the following ones:

- pin 2 (RCT), pin 6 (COMP) and pin 16 (S-BY) of the L5991A.
- pin 5 (ZCD) and pin 7 (GD) of the L6561.
- PFC pre-regulator's and flyback stage's output voltage (across C28 and C24 respectively).

To start the application board the input voltage has to be applied quickly. If the voltage is increased manually from zero, as prudent experimenter usually do with an unfamiliar unit, most probably the application board will not start: when the input voltage is low the converter works open-loop, then a slowly rising input voltage causes the "out of regulation" condition to last long. This will eventually trigger the overload protection circuit (TR5, R37, C14 and D8) that shuts off the L5991 and locks the system until the board is disconnected from the input source.

Like in any offline circuit, extreme caution must be used when working with the application board because it contains dangerous and lethal potentials. The application must be tested with an isolation transformer connected between the AC mains and the input of the board to avoid any risk of electrical shock.

Board evaluation: bench results and significant waveforms

In the following tables the results of some bench evaluations are summarized. A number of waveforms showing the interaction between the two stages are presented for user's reference.

Table 5. 80W AC-DC adapter with PFC and Standby: typical performance

Parameter	Value	Unit
Regulated Output Voltage (@ $V_{in} = 220 \text{ Vac}$, $I_{out} = 4.5 \text{ A}$)	18.056	V
Line & Load Regulation ($V_{in} = 90 \text{ to } 265 \text{ Vac}$, $I_{out} = 0 \text{ to } 4.5 \text{ A}$)	50	mV
High-frequency Output Voltage Ripple (@ $V_{in} = 90 \text{ Vac}$, $I_{out} = 4.5 \text{ A}$)	20	mV
Line-frequency Output Voltage Ripple (@ $V_{in} = 220 \text{ Vac}$, $f_L = 50 \text{ Hz}$, $I_{out} = 4.5 \text{ A}$)	< 5	mV
Output power for Normal-to-Standby mode transition (@ $V_{in} = 220 \text{ Vac}$)	22.1	W
Output power for Standby-to-Normal mode transition (@ $V_{in} = 220 \text{ Vac}$)	28.1	W
Minimum Full-load PFC Efficiency (@ $V_{in} = 90 \text{ Vac}$)	87.5	%
Full-load Flyback Efficiency (@ $V_{in} = 400 \text{ Vdc}$)	86.7	%
Minimum Full-load Total Efficiency (@ $V_{in} = 90 \text{ Vac}$)	75.9	%
Maximum No-load Input Power (@ $V_{in} = 265 \text{ Vac}$)	0.9	W
Typical Power Factor (@ $V_{in} = 220 \text{ Vac}$, $I_{out} = 4.5 \text{ A}$)	0.950	-
Typical THD (@ $V_{in} = 220 \text{ Vac}$, $I_{out} = 4.5 \text{ A}$)	11.5	%

AN1440 APPLICATION NOTE

Table 6. 80W AC-DC adapter with PFC and Standby: System Evaluation

Vac [V]		90	110	135	175	220	265
Iout [A]	4.5	$\eta = 75.9\%$ PF = 0.998 THD = 4.9%	$\eta = 79.2\%$ PF = 0.998 THD = 3.5%	$\eta = 80.6\%$ PF = 0.994 THD = 4.8%	$\eta = 82.0\%$ PF = 0.979 THD = 8.6%	$\eta = 82.5\%$ PF = 0.950 THD = 11.5%	$\eta = 82.9\%$ PF = 0.916 THD = 12.5%
	2.25	$\eta = 79.1\%$ PF = 0.997	$\eta = 80.7\%$ PF = 0.992	$\eta = 81.2\%$ PF = 0.982	$\eta = 81.7\%$ PF = 0.951	$\eta = 81.7\%$ PF = 0.900	$\eta = 81.8\%$ PF = 0.832
	1.20	$\eta = 76.3\%$	$\eta = 78.4\%$	$\eta = 79.8\%$	$\eta = 81.2\%$	$\eta = 81.5\%$	$\eta = 81.5\%$

Table 7. 80W AC-DC adapter with PFC and Standby: Load Regulation

Iout [A]	0	1.0	2.0	2.5	3.5	4.5
Vout [V]	18.104	18.088	18.080	18.076	18.066	18.056

Table 8. 80W AC-DC adapter with PFC and Standby: Light-load Input Power (@ Pout = 0.5 W)

VAC [V]	90	110	135	175	220	265
Pin [W]	1.0	1.0	1.0	1.1	1.3	1.4

Table 9. 80W AC-DC adapter with PFC and Standby: No-load Input Power

VAC [V]	90	110	135	175	220	265
Pin [W]	0.4	0.5	0.5	0.6	0.7	0.9

Table 10. 80W AC-DC adapter with PFC and Standby: Typical Wake-up Time

VAC [V]	90	110	135	175	220	265
TWAKE [s]	0.15	0.12	0.10	0.07	0.06	0.05

Figure 5. 80W AC-DC adapter with PFC and Standby: conducted EMI @ Vin = 110 Vac, Pout = 80 W

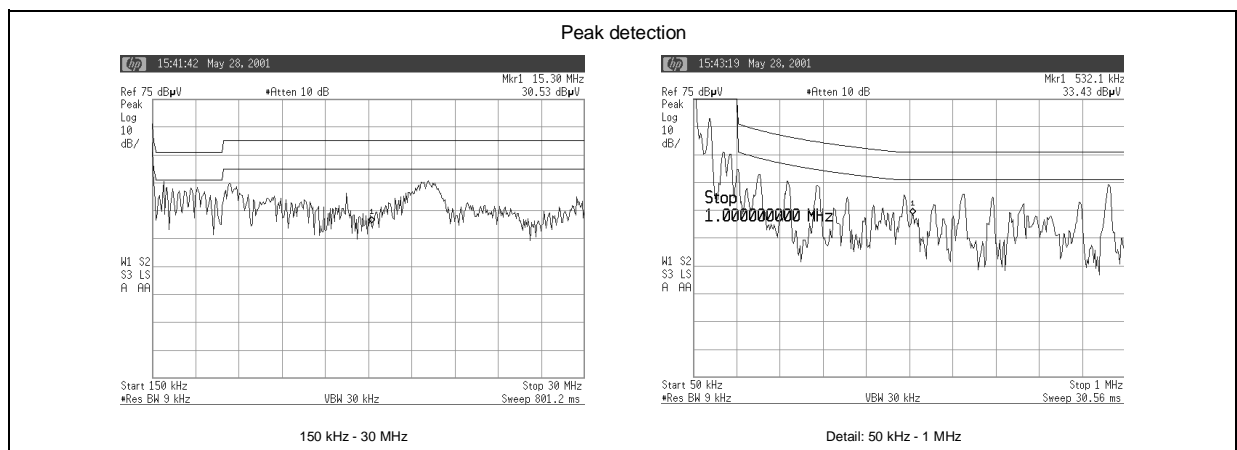

Figure 6. 80W AC-DC adapter with PFC and Standby: conducted EMI @ Vin = 220 Vac, Pout = 80 W

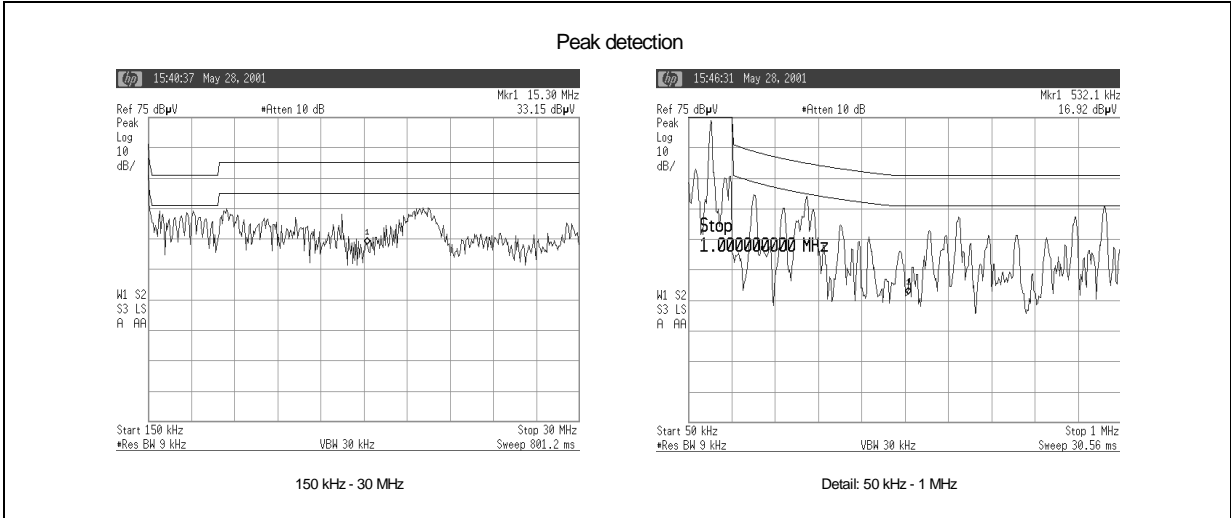

Figure 7. 80W AC-DC adapter with PFC and Standby: Low-frequency Harmonic Contents

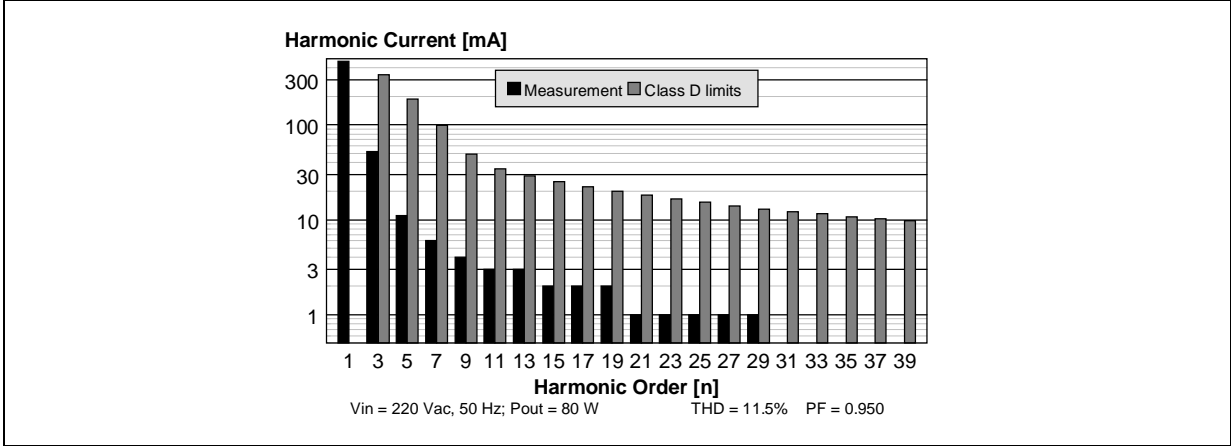
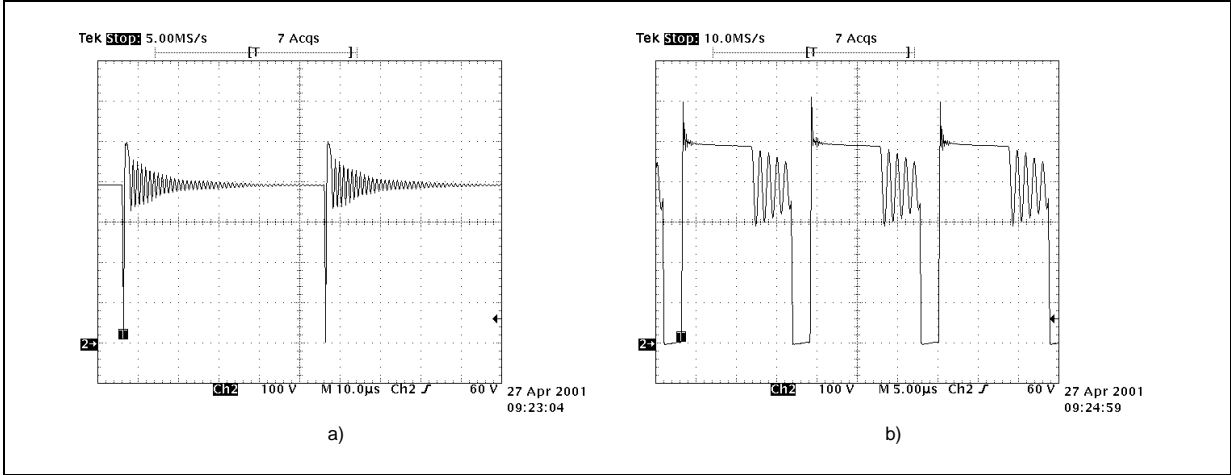

Figure 8. 80W AC-DC adapter with PFC and Standby: Q2 drain at a) no-load, b) full-load



AN1440 APPLICATION NOTE

Figure 9. 80W AC-DC adapter with PFC and Standby: Load transient 0.1↔4.5 A @ Vin = 90 Vac (1)

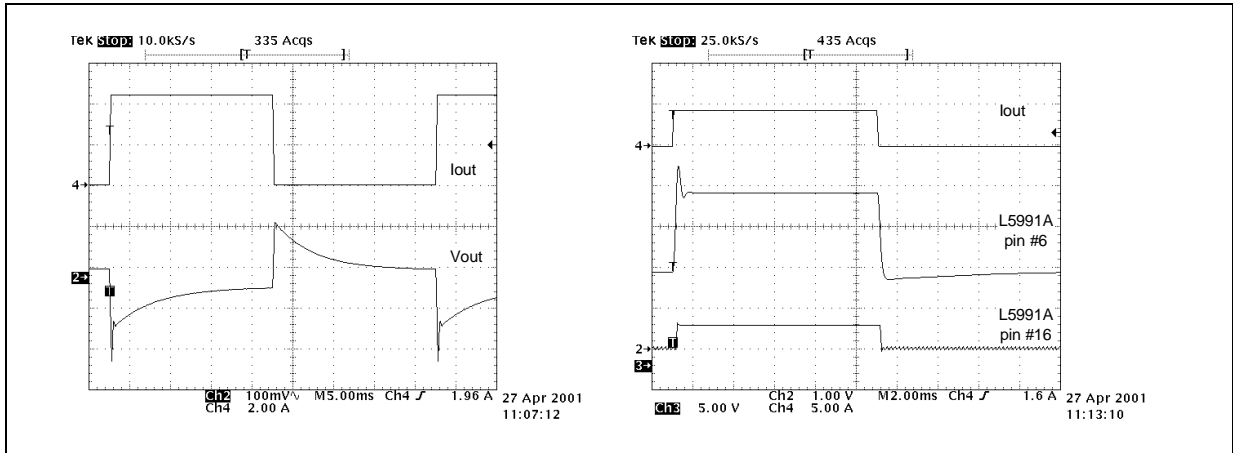

Figure 10. 80W AC-DC adapter with PFC and Standby: Load transient 0.1↔4.5 A @ Vin = 90 Vac (2)

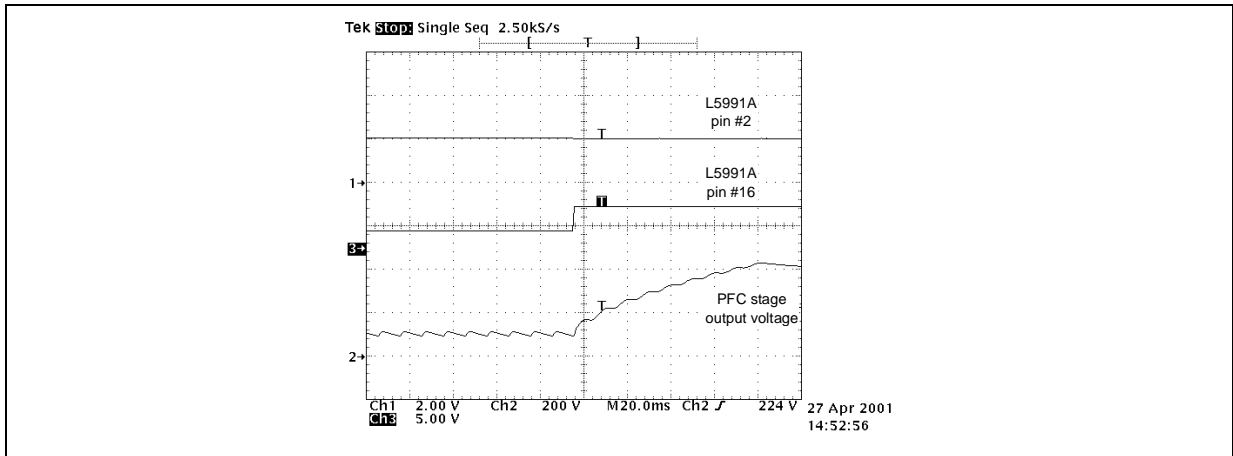
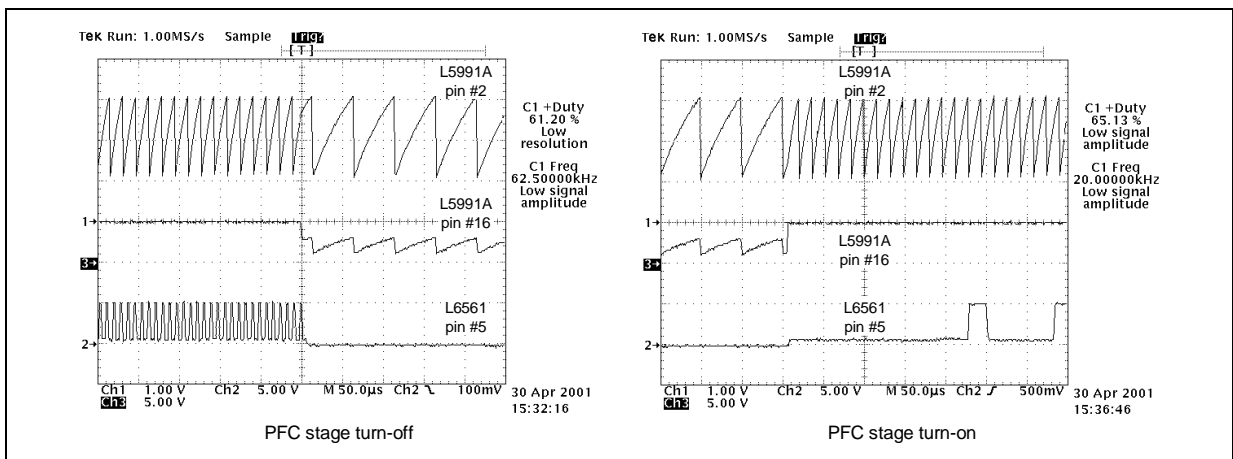

Figure 11. 80W AC-DC adapter with PFC and Standby: Load transient 0.1↔4.5 A @ Vin = 90 Vac (3)



ACKNOWLEDGMENTS

Thanks to Marco A. Legnani for his valuable support in the development of this project.

REFERENCES

- [1] "L6561 Power Factor Corrector" Datasheet
- [2] "L5991/A Primary Controller with Standby" Datasheet
- [3] "Minimize Power Losses of Lightly Loaded Flyback Converters with the L5991 PWM Controller" (AN1049)
- [4] "L6561, Enhanced Transition Mode Power Factor Corrector" (AN966)
- [5] "How to Handle Short Circuit Conditions with ST's Advanced PWM Controllers" (AN1215)

Information furnished is believed to be accurate and reliable. However, STMicroelectronics assumes no responsibility for the consequences of use of such information nor for any infringement of patents or other rights of third parties which may result from its use. No license is granted by implication or otherwise under any patent or patent rights of STMicroelectronics. Specifications mentioned in this publication are subject to change without notice. This publication supersedes and replaces all information previously supplied. STMicroelectronics products are not authorized for use as critical components in life support devices or systems without express written approval of STMicroelectronics.

The ST logo is a registered trademark of STMicroelectronics
© 2001 STMicroelectronics - All Rights Reserved

STMicroelectronics GROUP OF COMPANIES
Australia - Brazil - Canada - China - Finland - France - Germany - Hong Kong - India - Israel - Italy - Japan -Malaysia - Malta - Morocco -
Singapore - Spain - Sweden - Switzerland - United Kingdom - United States.
<http://www.st.com>