

MAAM71200

Low Noise GaAs MMIC Power Amplifier 7.5 - 12.0 GHz

Rev. V6

Features

- Noise Figure: 2.3 dB Typical
- Gain: 16.5 dB Typical
- Low Bias Current
- Single Bias Supply
- On-Chip Bias Network
- DC Decoupled RF Input and Output

Description

The MAAM71200 die is a wide-band, low noise, MMIC amplifier. It includes two integrated gain stages and employs series inductive feedback to obtain excellent noise figure and a good, 50 Ω , input and output impedance match over the entire frequency band. The MAAM71200 operates from a single +4 V supply.

The MAAM71200 is manufactured in-house using a reliable, 0.5-micron, GaAs MESFET process. This product is 100% RF tested to ensure compliance to performance specifications.

Ordering Information

Part Number	Package
MAAM71200	Die

Absolute Maximum Ratings ¹

Parameter	Absolute Maximum
Voltage	+7 V
Input Power	+20 dBm
Operating Temperature	-55°C to +125°C
Storage Temperature	-65°C to +150°C

1. Exceeding any one or combination of these limits may cause permanent damage to this device.

Die

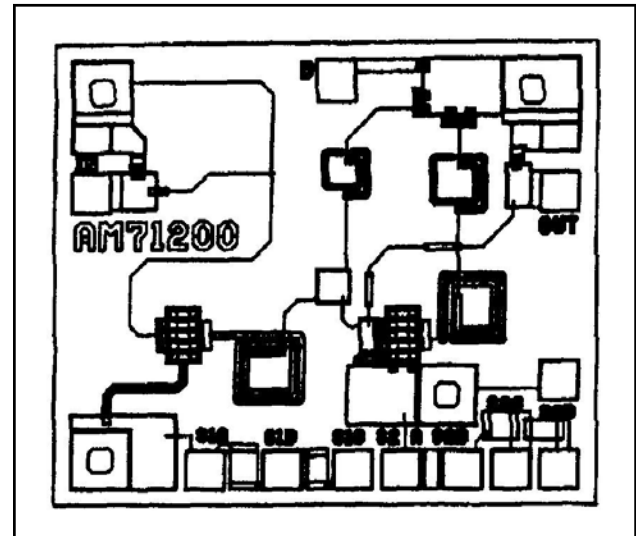

Schematic

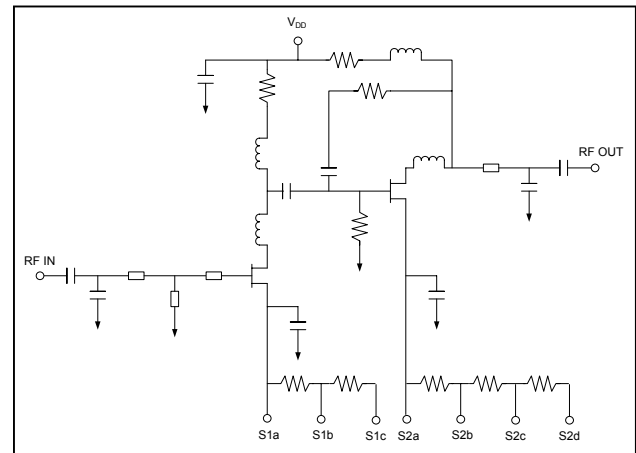

Electrical Specifications: $T_A = 25^\circ\text{C}$, $Z_0 = 50 \Omega$, $V_{DD} = +4 \text{ V}$, $I_{DD} = 40 \text{ mA Typ, 55 mA Max.}$

Parameter	Test Conditions	Units	Min.	Typ.	Max.
Gain ²	—	dB	15.0	16.5	—
Gain Flatness	—	dB	—	± 0.8	—
Noise Figure ²	—	dB	—	2.3	3.2
Input VSWR Output VSWR	—	Ratio Ratio	— —	1.8:1 1.5:1	— —
Output Power at 1 dB Gain Compression	—	dBm	—	12	—
Third Order Intercept	—	dBm	—	22	—
Reverse Isolation	—	dB	—	30	—

2. 100% on-wafer tested.

Typical Performance Curves

Gain

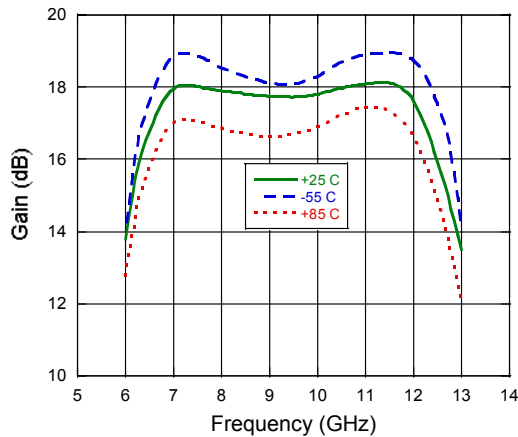

Noise Figure

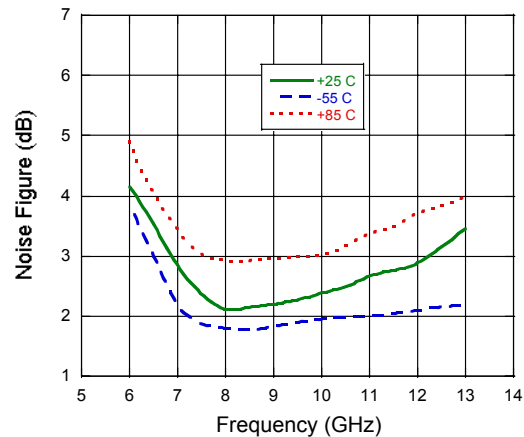

VSWR

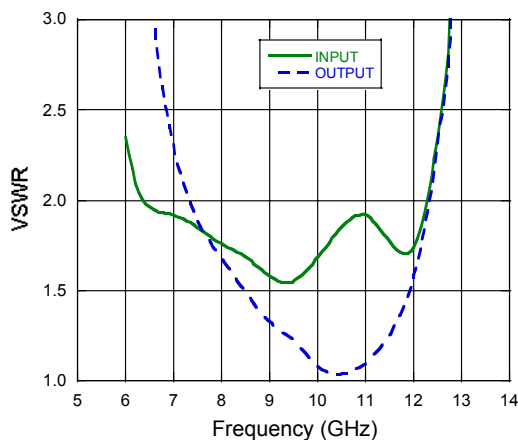

MAAM71200

Low Noise GaAs MMIC Power Amplifier 7.5 - 12.0 GHz

Rev. V6

Typical Bias Configuration ^{3,4,5}

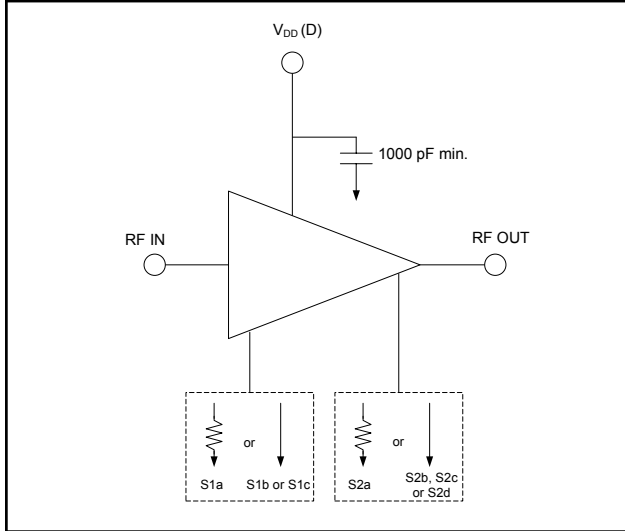

3. Nominal bias is obtained with on-chip resistors by grounding pads S1b and S2b.
4. Ground pads S1b and S2c for lower current or ground pads S1c and S2d for lowest current using on-chip resistors.
5. Optional biasing can be obtained with off-chip resistors bonded to pads S1a and S2a. Adjusting the bias can customize the performance to suit special requirements.

Outline Drawing

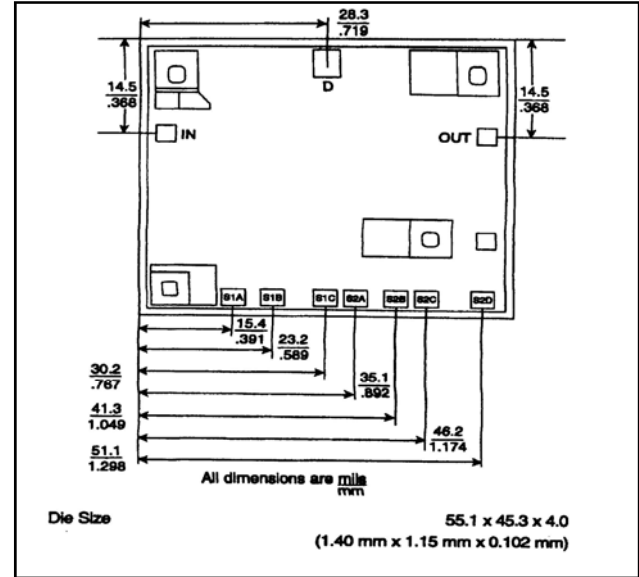

Handling Procedures

Permanent damage to the MAAM71200 may occur if the following precautions are not adhered to:

- A. Cleanliness - The MAAM71200 should be handled in a clean environment. DO NOT attempt to clean assembly after the MAAM71200 is installed.
- B. Static Sensitivity - All die handling equipment and personnel should comply with DOD-STD-1686 Class I.
- C. Transients - Avoid instrument and power supply transients while bias is connected to the MAAM71200. Use shielded signal and bias cables to minimize inductive pick-up.
- D. General Handling - DO NOT touch the surface of the die. It is recommended that the MAAM71200 die be handled along the long side with a sharp pair of tweezers.

Mounting

The MAAM71200 is back-metallized with Pd/Ni/Au (100/1, 000/30,000Å) metallization. It can be die-mounted using Au/Sn eutectic preforms or a thermally and electrically conductive epoxy. The attachment surface should be clean and flat.

Eutectic Die Attach:

- A. An 80/20 Au/Sn preform is recommended with a work surface temperature of approximately 255°C and a tool temperature of 265°C. When hot 95/5 nitrogen/hydrogen gas is applied, solder temperature should be approximately 290°C.
- B. DO NOT expose the MAAM71200 to a temperature greater than 320°C for more than 20 seconds. No more than 3 seconds of scrubbing should be required for attachment.

Epoxy Die Attach:

- A. Electrically conductive epoxy is required.
- B. Apply a minimum amount of epoxy and place the MAAM71200 into position. A thin epoxy fillet should be visible around the perimeter of the die.
- C. Cure epoxy per manufacturer's recommended schedule.

Bonding

- A. Ball or wedge bond with 1.0 mil diameter gold wire of 3.0 mil x 0.5 mil ribbon. Thermosonic bonding with a nominal stage temperature of 150°C and a ball bonding force of 40 to 50 grams or wedge bonding force of 18 to 22 grams is recommended. Ultrasonic energy and time should be adjusted to the minimum levels necessary to achieve reliable bonds.
- B. Bonds should be started on the die and terminated on the package.
- C. Bonding pads are 4.0 x 4.0 mils minimum.