

VOLTAGE MODE PWM POWER SUPPLY WITH BUILT-IN SUPERVISOR, PROTECTION AND REGULATION FOR PCs

DESCRIPTION

The SD6109 is a power management IC for computers. It integrates various monitoring functions and protections, such as AC fail detection, over power protection, negative voltage protection, over/under voltage protection and provides power down signal for PG.

Built-in high precision oscillator provides accurate protection and delay time for monitoring. And internal regulators TL431 are used for stable output 3.3V and 5V, with few peripheral components.

Built-in soft-start decreases stress of transformer against saturation. SD6109 used for pull-push or half-bridge power system with high efficiency and stability.

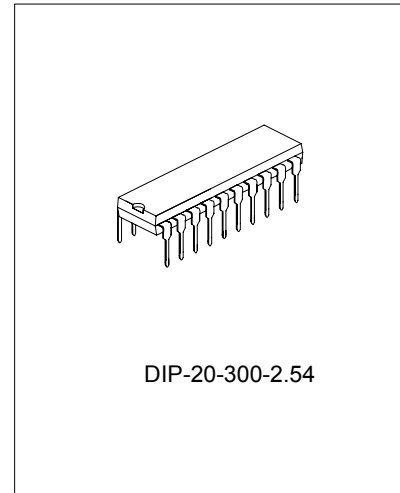

FEATURES

- * Advanced Bi-CMOS process.
- * 4KV HBM ESD protection
- * Bipolar structure adopted in Shunt regulators TL431, with high reliability
- * Over voltage protection for 3.3V/5V/12V
- * Under voltage protection for 3.3V/±5V/±12V
- * Over power protection
- * Short circuit protection
- * AC-input under voltage protection
- * PG Circuit
- * PSON for remote control
- * Delay time for PSON or PG signals
- * Two bypass regulators for 3.3V and 5V- voltage stability
- * Soft start and maximum 93% duty cycle

APPLICATIONS

- * Switching mode power supply for computers.

ORDERING INFORMATION

Part No.	Package	Marking
SD6109	DIP-20-300-2.54	SD6109

BLOCK DIAGRAM

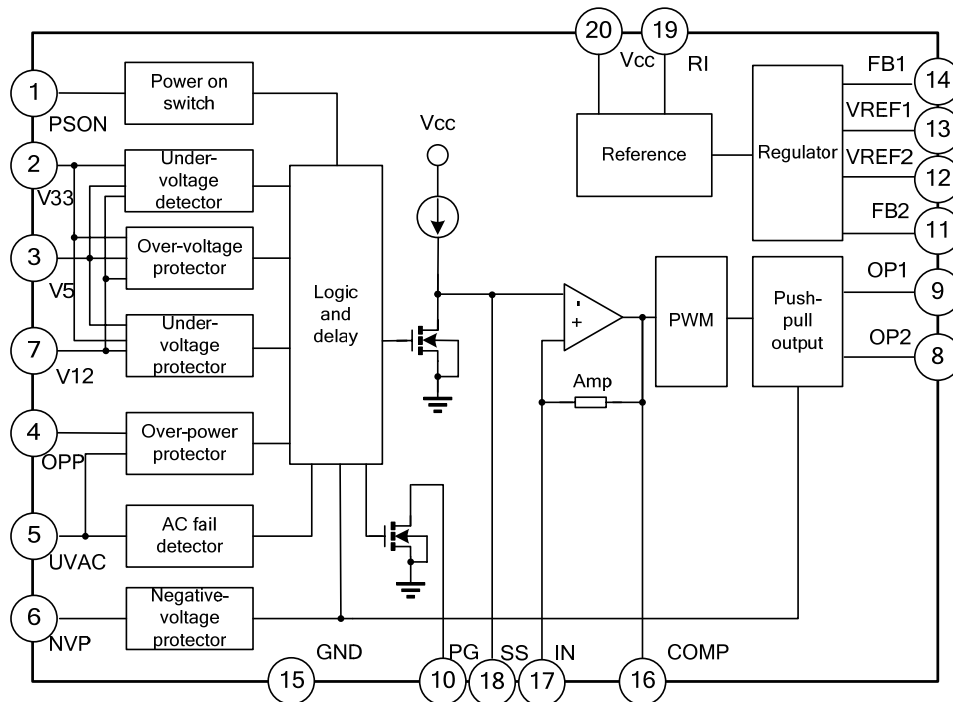

ABSOLUTE MAXIMUM RATING

Characteristics	Symbol	Rating	Unit
Supply Voltage(pin 20)	VCC	12	V
Regulator Output At Pins FB1, FB2 Pins	VFB	16	V
Output Current At Pins PG, FB1, FB2 Pins	IOUT	30	mA
Power Dissipation(Tamb=25°C)	PD	1.5	W
Power Dissipation(Tamb=90°C)	PD	0.5	W
Thermal Resistance, Junction-To-Air	RθJA	82.5	°C/W
Operating Temperature Range	Tamb	-30 ~ +125	°C
Storage Temperature Range	Tstg	-55~+155	°C

ELECTRICAL CHARACTERISTICS (Unless otherwise stated, VCC=5V, Tamb=25°C)

Characteristics		Symbol	Test condition	Min.	Typ.	Max.	Unit
Supply Voltage		VCC	All functions are normal.	4.5	5.0	7.0	V
Supply Current		ICC	PG High	--	5	10	mA
Over-Voltage Protection 3.3V		VOVP1	-	3.9	4.1	4.3	V
Over-Voltage Protection 5V		VOVP2	-	5.8	6.1	6.5	V
Over-Voltage Protection 12V		VOVP3	-	13.9	14.5	14.9	V
Under-Voltage Protection 3.3V		VUVP1	-	2.0	2.6	2.8	V
Under-Voltage Protection 5V		VUVP2	-	3.0	3.6	3.9	V
Under-Voltage Protection 12V		VUVP3	-	6.0	7.2	8.0	V
Under-Voltage Sense 3.3V For PG Low		VUVS1	-	2.5	2.8	3.0	V
Under-Voltage Sense 5V For PG Low		VUVS2	-	4.0	4.3	4.5	V
Under-Voltage Sense 12V For PG Low		VUVS3	-	9.4	10.1	10.4	V
Over-Power Protection.		VOPPS	VUVAC = 1.5V	2.02	2.4	2.66	V
Negative Voltage Protection: Voltage Level		VNVP	-	1.9	2.05	2.2	V
Negative Voltage Protection: Source Current		INVP	RI = 75KΩ	50	61	72	μA
Timing For Over-Voltage Protection		tOVP	RI = 75KΩ	0.5	0.7	1.3	ms
Timing For Under-Voltage Protection		tUVP	RI = 75KΩ	0.9	2.4	3.8	ms
Timing For Under-Voltage Sense for PG Low		tUVS	RI = 75KΩ	0.5	1.2	1.9	ms
Timing for Over-Power-Protection		tOPP	RI = 75KΩ	4.0	7.0	10.0	ms
Timing for Negative Voltage Protection		tNVP	RI = 75KΩ	4.0	7.0	10.0	ms
Bypass Regulator (FB1, VREF1, FB2, VREF2)	Reference Voltage	VREF	IFB = 0.5mA, Tamb = 25°C	2.475	2.5	2.525	V
	Line Regulation	REGLI-FB	4 < VFB < 16V	-	1	-	MV/V
	Output Sinking Current Capability	IOUT-FB	VFB > 2V	10	-	-	mA
PG	PG Delay	tPG	RI = 75KΩ	200	300	400	ms
	UVAC Voltage Sense for PG	VUVAC	-	0.65	0.7	0.75	V
	PG Output Rising Time	tR	CL = 100pF	-	1	-	us
	PG Falling Time	tF	CL = 100pF	-	300	-	ns
	PG Output Saturation Level	VOL2	IPG = 5mA	-	-	0.5	V
	PG Leakage Current Collector	ION2	VPG = 5V	-	-	1	μA

Characteristics		Symbol	Test condition	Min.	Typ.	Max.	Unit	
Remote Control	PSON Input Threshold Level	VPSON	-	1	1.4	2.0	V	
	Remote Input Driving Current	IPSON	-	-	-	0.5	mA	
	Timing PSON to On/Off	On	tPSON(ON)	RI = 75kΩ	20	40	50	ms
		Off (PS-off)	tPSON(OFF)		10	20	30	ms
	Timing PG low to Power Off	tPSOFF	RI = 75kΩ	2	4.8	6.5	ms	
Error Amplifier	Reference Voltage	V2.5	-	2.45	2.5	2.55	V	
	Input Bias Current	IIB	-	-	-	0.1	μA	
	Open-Loop Voltage Gain	AVOL	-	50	60	-	dB	
	Unity Gain Bandwidth	BW	-	0.3	1	-	MHz	
	Power Supply Rejection Ratio	PSRR		50	-	-	dB	
Oscillator	PWM Frequency	FOSC	RI = 75kΩ	60	65	70	kHz	
Soft-Start	Charge Current	ISS	RI = 75kΩ	4.0	5.7	7.0	μA	
	Duty Cycle	DC	-	85	-	93	%	
PWM Output	Output Voltage Low	VOL	Io = 5mA	-	-	0.5	V	
	Output Voltage High	VOH	V12 = 12V	4	-	-	V	
	Output Impedance of VOH	RO	-	1.5	-	3.3	kΩ	

PIN CONFIGURATIONS

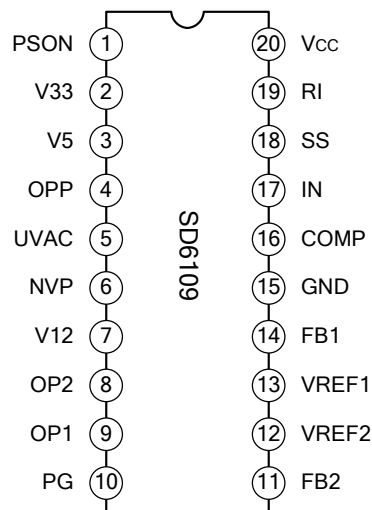

PIN DESCRIPTIONS

Pin No.	Pin Name	I/O	Description
1	PSON	I	Remote switch input for CPU or controller. Control the PWM Output.
2	V33	I	3.3V over-voltage/under-voltage control sense input.
3	V5	I	5V over-voltage/under-voltage control sense input.
4	OPP	I	Over-power sense input.
5	UVAC	I	AC fail detection.
6	NVP	I	The protection input for negative output.
7	V12	I	12V over-voltage/under-voltage control sense input.
8	OP2	O	The totem-pole output drivers of push-pull PWM. The maximum duty cycle (OP1 or OP2) is 46%.
9	OP1	O	The totem-pole output drivers of push-pull PWM.
10	PG	O	PG logic output, 0 or 1 (open-collector). PG=1 means that the power is good for operation.
11	FB2	O	Output of second converter regulation loop.
12	VREF2	I	Reference comparison input for second converter regulation loop. 2.5V.
13	VREF1	I	Reference comparison input for first converter regulation loop. 2.5V.
14	FB1	O	Output of first converter regulation loop.
15	GND	-	Ground.
16	COMP	I/O	Error amplifier output and the input of the PWM comparator.
17	IN	I	The negative input of error amplifier. The positive input of error amplifier is connected to 2.5V reference voltage.
18	SS	I/O	The soft-start. It is settable through external capacitor. The current source output at this pin is 5.7uA and the voltage is clamped at 2.5V.
19	RI	I	Connected to external resistor for the reference setting.
20	VCC	-	Supply voltage. It is connected to 5V-standby.

FUNCTION DESCRIPTION

The SD6109 is a power management IC for computers. It integrates various monitoring functions and protections, such as AC fail detection, over power protection, negative voltage protection, over/under voltage protection and provides power down signal for PG. Built-in high precision oscillator provides accurate protection and delay time for monitoring. And internal regulators TL431 are used for stable output 3.3V and 5V, with few peripheral components. Built-in soft-start decreases stress of transformer against saturation. SD6109 used for pull-push or half-bridge power system with high efficiency and stability.

1. TIMING DIAGRAM

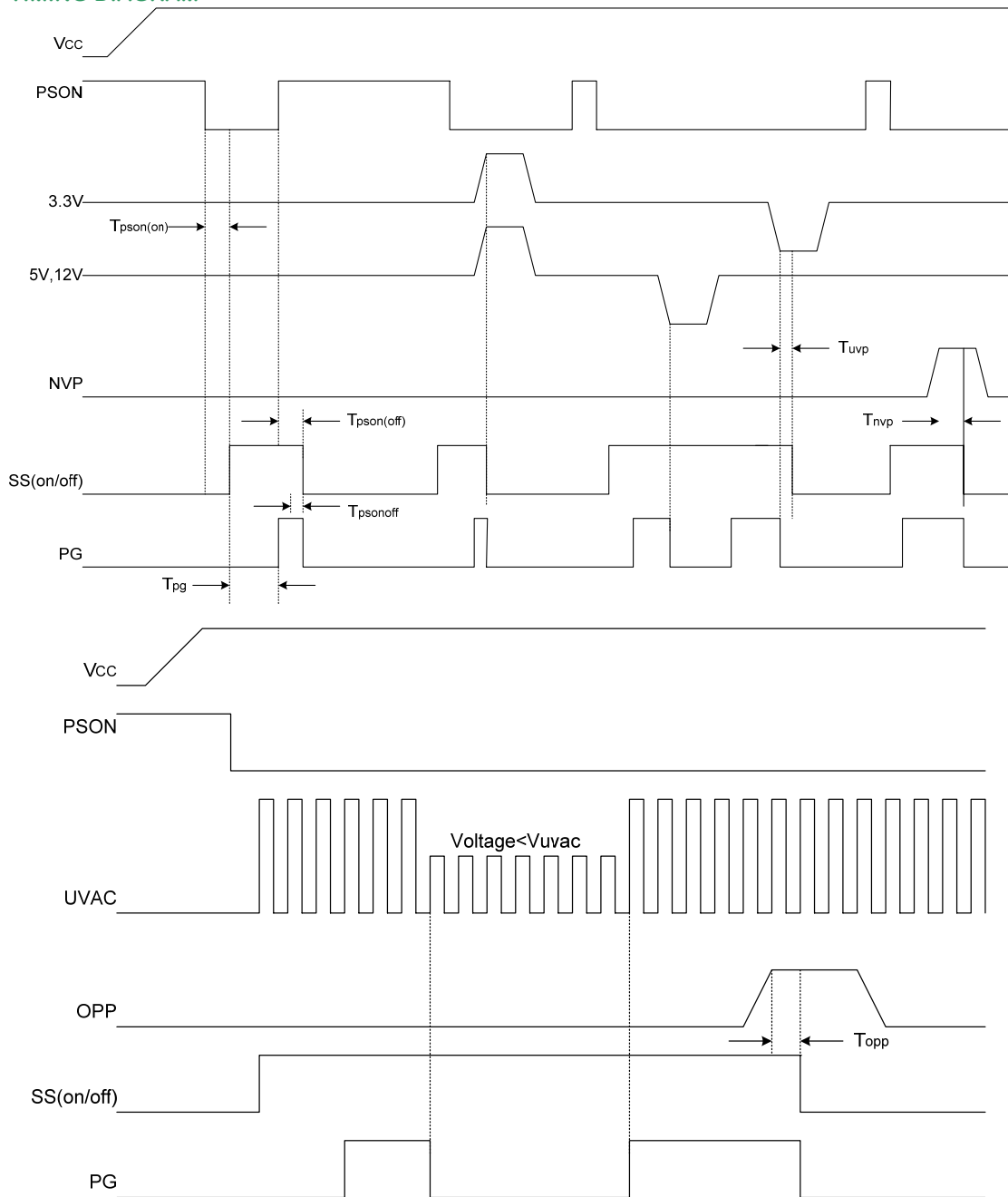

2. Remote Switch Control (PSON)

The PC generates the remote switch control signal which is connected to PSON. When the control signal is low, PC power is on. And when the control signal is high, PC power is off.

3. AC Fails Detection (UVAC)

The AC line voltage is coupled from the primary side to the secondary side through the main transformer, and UVAC is connected to the secondary side by a resistor. When UVAC voltage drops below 0.7V and maintains this situation over 200us, the PG signal will be pulled low, and it indicates that the AC line is power-down. The voltage amplitude of the PWM switching signal from the secondary side is proportional to the AC line voltage. Adjusting the ratio of the voltage divider can set the threshold for the power-down.

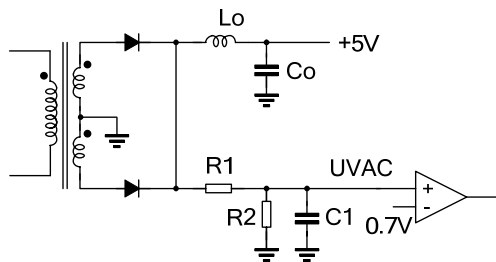

4. Over Power Protection (OPP)

The over power protection is designed to detect over power and short circuit. When the voltage of OPP is higher than 2.4V and maintains this situation over 7msec, PG will be pulled low and the power outputs will be locked.

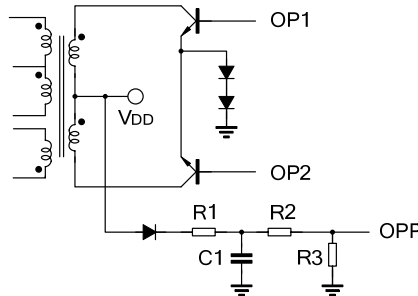

5. Negative Voltage Protection (NVP)

The negative voltage protection is designed to provide under voltage protection for negative voltage output. Overload and short circuit can cause under voltage of negative voltage output. When the voltage of NVP is higher than 2.1V and this situation exists for longer than 7msec, the power outputs will be off and be locked. Adjusting the resistor will set the threshold for locking the power outputs off. The threshold is determined by:

$$V_{NVP} = I_{NVP} \times (R1 + R2) + V - 12V$$

$$V_{NVP} = I_{NVP} \times R1 + V - 5V - 0.7V$$

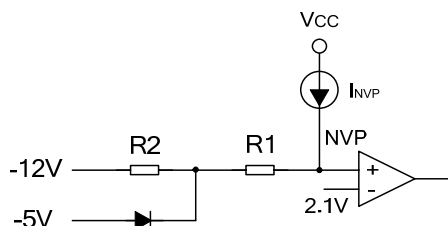

TYPICAL APPLICATION CIRCUIT

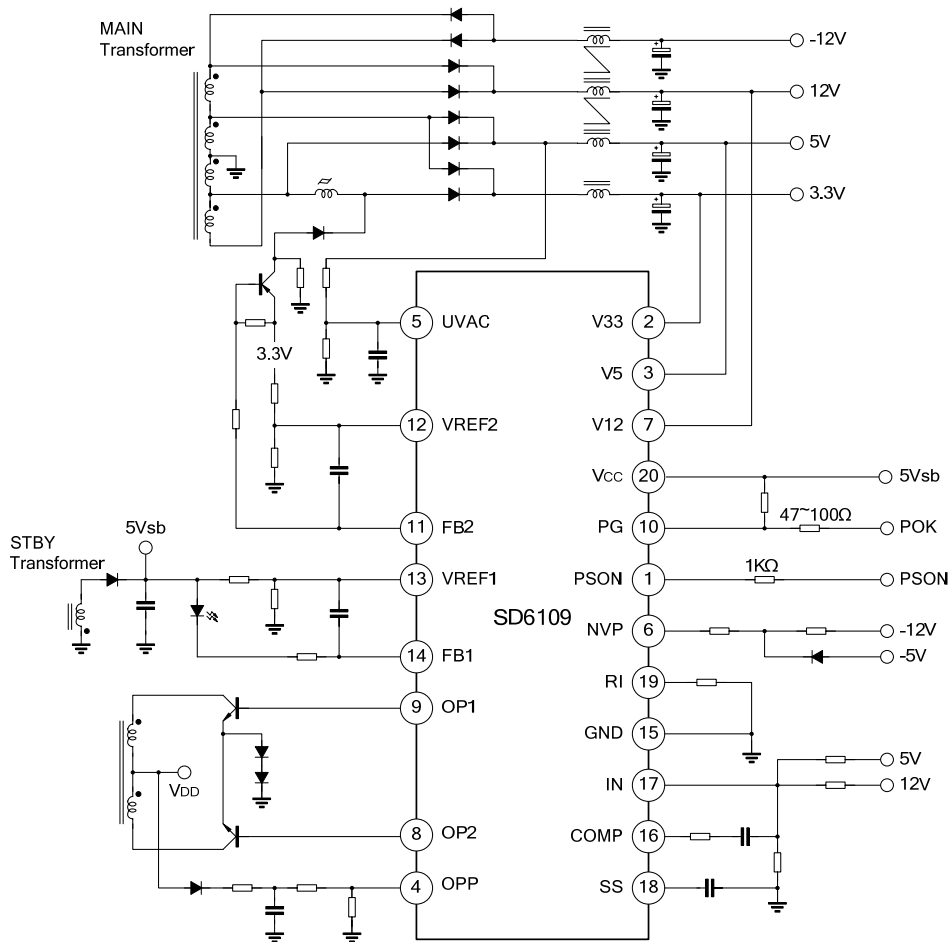

Note: The circuit and parameters are for reference only, please set the parameters of the real application circuit based on the practical test.

DETAIL APPLICATION CIRCUIT

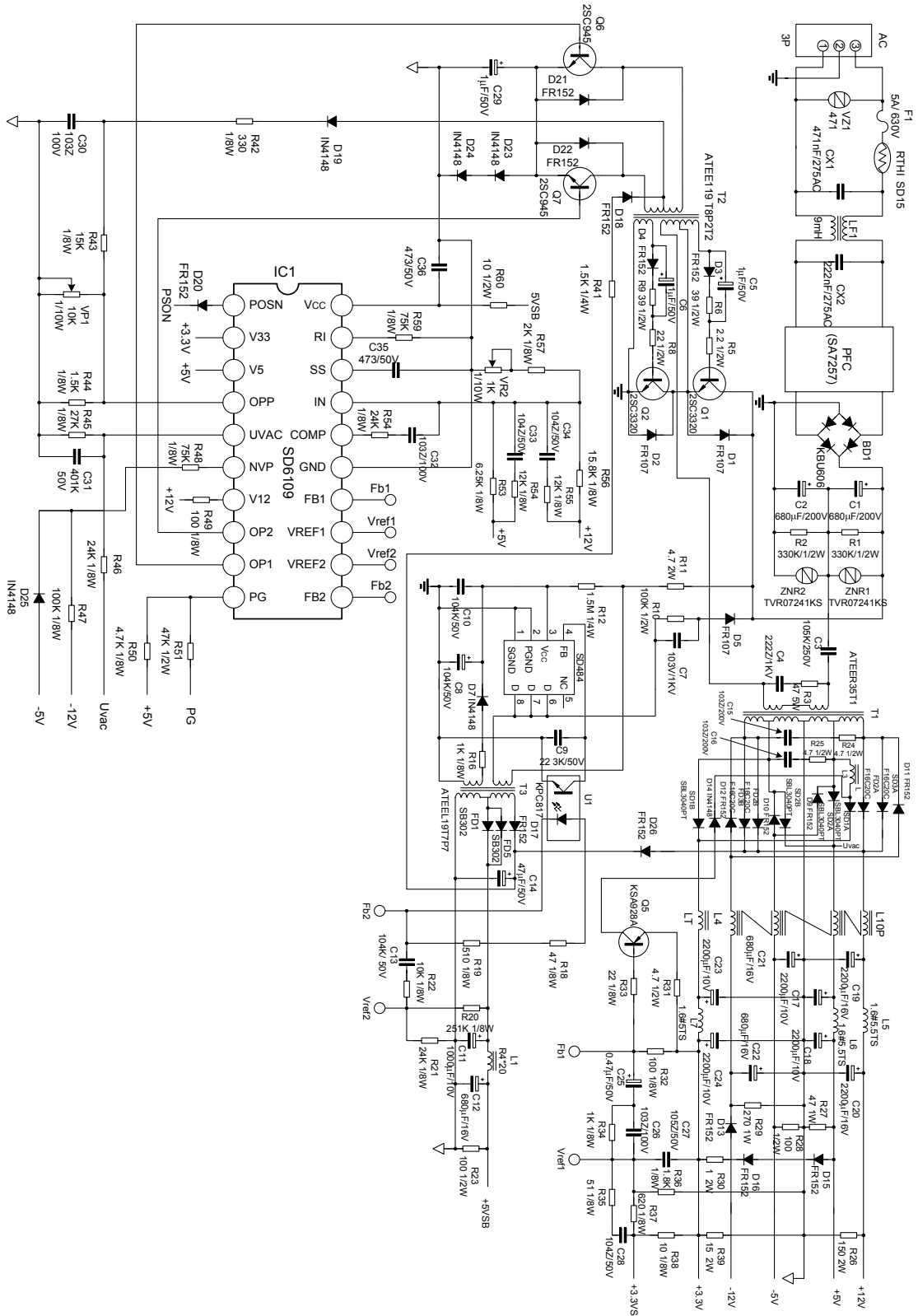

PACKAGE OUTLINE

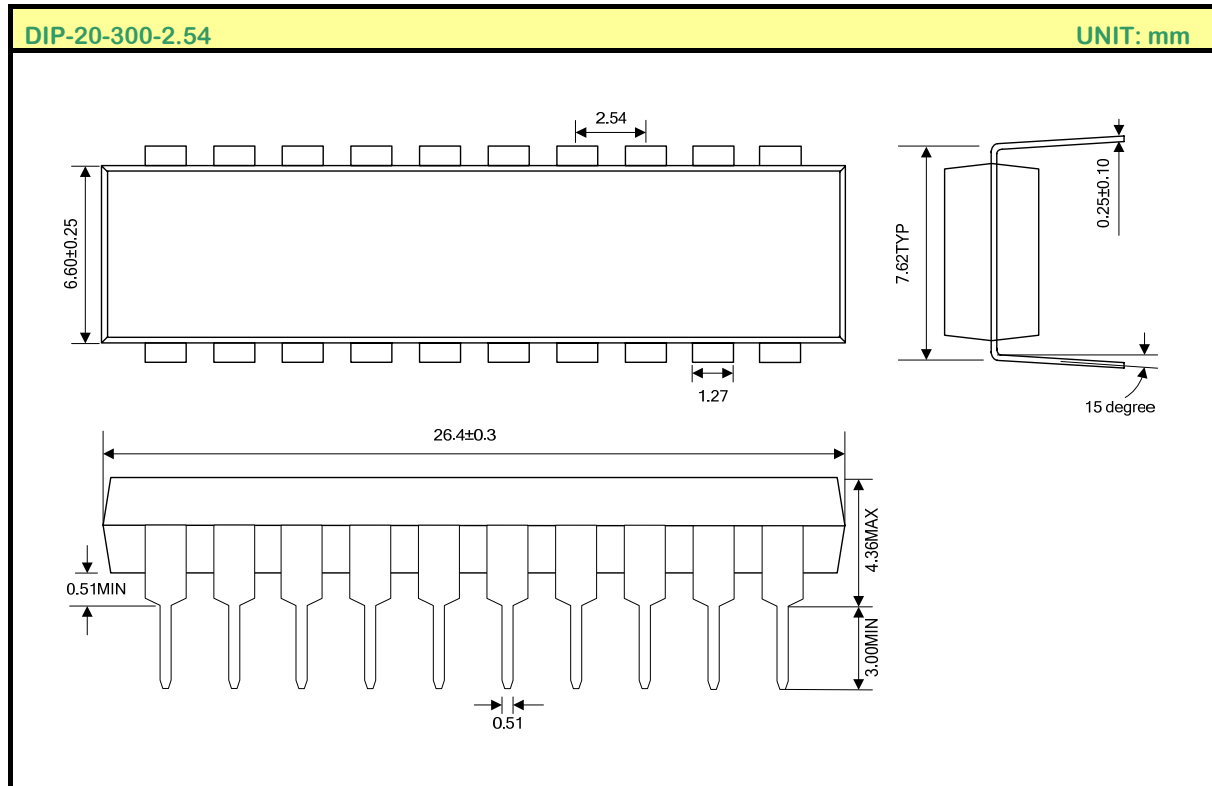

MOS DEVICES OPERATE NOTES:

Electrostatic charges may exist in many things. Please take following preventive measures to prevent effectively the MOS electric circuit as a result of the damage which is caused by discharge:

- The operator must put on wrist strap which should be earthed to against electrostatic.
- Equipment cases should be earthed.
- All tools used during assembly, including soldering tools and solder baths, must be earthed.
- MOS devices should be packed in antistatic/conductive containers for transportation.

Disclaimer:

- Silan reserves the right to make changes to the information herein for the improvement of the design and performance without further notice!
- All semiconductor products malfunction or fail with some probability under special conditions. When using Silan products in system design or complete machine manufacturing, it is the responsibility of the buyer to comply with the safety standards strictly and take essential measures to avoid situations in which a malfunction or failure of such Silan products could cause loss of body injury or damage to property.
- Silan will supply the best possible product for customers!