



RGB Color Sensor Detects Subtle Color Differences—Most Advanced Color Sensor In the Industry

- LED light source insures ease of operation and long life
- No separate light source is required
- Remote control of color setting from PC or PLC
- 4-color memory
- 4-output models available
- 3 models: lensed, precision fiber-optic, versatile standard fiber-optic
- IP66
- Rugged die-cast metal housing

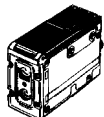
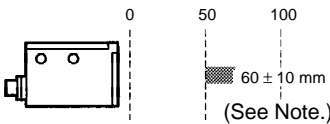
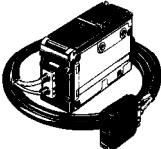
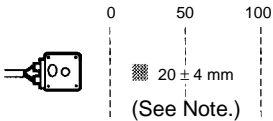
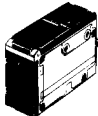

Ordering Information

■ RGB COLOR SENSOR

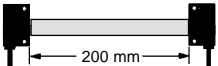
Type	Appearance	Sensing distance	Spot diameter	No. of outputs	Output	Part number
Lensed		 (See Note.)	12 mm	1	NPN	E3MC-A11
					PNP	E3MC-A41
				4	NPN	E3MC-MA11
					PNP	E3MC-MA41
Precision fiber-optic type	 The shape of the amplifier section is the same as for the E3MC-(M)A□□.	 (See Note.)	3 mm	1	NPN	E3MC-X11
					PNP	E3MC-X41
				4	NPN	E3MC-MX11
					PNP	E3MC-MX41
General-purpose fiber-optic type		Standard sensing distance E32-CC200  5 mm (See Note 2.) E32-T16  200 mm	Varies with the recommended fiber.	1	NPN	E3MC-Y11
					PNP	E3MC-Y41
				4	NPN	E3MC-MY11
					PNP	E3MC-MY41

Note: Refer to the *Specifications* section of this data sheet.

■ ACCESSORIES (ORDER SEPARATELY)

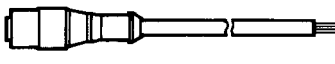
Item	Appearance	Description	Part number (length)
Sensor cable (2-m cable is included with the E3MC)		Replacement cable	E39-C1 (2M)
		5-meter cable	E39-C1 (5M)
Mounting bracket	---	Used for die-cast body mounting (See Note.)	E39-L114
	---	Used for DIN-rail mounting	E39-L115

Note: Included with sensor.

Specifications

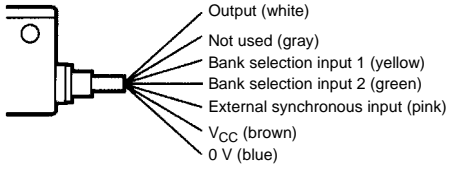
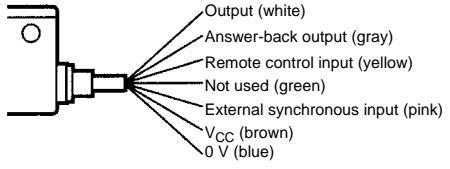
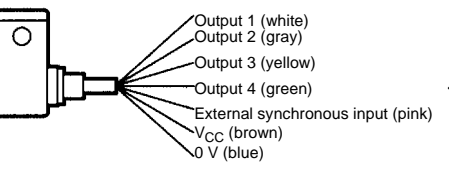
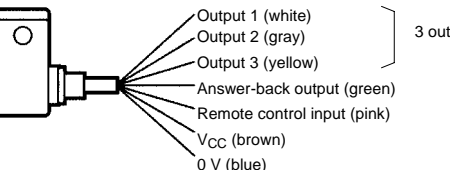
Type	Lensed	Precision fiber-optic type	General-purpose fiber-optic type
	E3MC-A□1, E3MC-MA□1	E3MC-X□1, E3MC-MX□1	E3MC-Y□1, E3MC-MY□1
Light source	Red (680 nm), green (525 nm), and blue (450 nm) LEDs		
Sensing distance	60±10 mm	20±4 mm	Varies with the recommended fiber. Refer to Engineering Data for details.
Spot diameter	12 dia.	3 dia.	
Supply voltage	12 to 24 VDC±10%, ripple (p-p) 10% max.		
Current consumption	100 mA max.		
Output	Load current: 100 mA max. NPN open collector output with a maximum residual voltage of 1.2 V for the E3MC-(M)A11, E3MC-(M)X11, and E3MC-(M)Y11. PNP open collector output with a maximum residual voltage of 2.0 V for the E3MC-(M)A41, E3MC-(M)X41, and E3MC-(M)Y41. L.O./D.O., switch selectable		
Response time	1-output model: Standard mode: 3 ms max. High-speed mode: 1 ms max. (switch selectable) 4-output model: Standard mode: 6 ms max. High-speed mode: 2 ms max. (switch selectable)		
Timer function	40-ms OFF-delay timer (ON/OFF switch selectable)		
Color detection	Four colors stored in teaching operation with manual threshold level adjustments.		
Color detection mode	Mode C: RGB ratio detection; adapts to changes in conditions Mode I: RGB light intensity detection; highest precision		} Switch selectable
Mode selection	<p>E3MC-□11/-□41 Mode A (Factory-set)</p>  <p>Colors in parentheses are lead wire colors.</p> <p>Mode B (for remote teaching)</p>  <p>Colors in parentheses are lead wire colors.</p> <hr/> <p>E3MC-M□11/-□M41 Mode A (Factory-set)</p>  <p>Colors in parentheses are lead wire colors.</p> <p>Mode B (for remote teaching)</p>  <p>Colors in parentheses are lead wire colors. } 3 outputs</p>		

(This table continues on the next page.)

Specifications Table - continued from previous page

Type	Lensed	Precision fiber-optic type	General-purpose fiber-optic type
	E3MC-A□1, E3MC-MA□1	E3MC-X□1, E3MC-MX□1	E3MC-Y□1, E3MC-MY□1
Remote control input (See Note 1.) (mode B only)	The following control is performed according to the control signal input. E3MC-□11/-□41 Bank selection, remote teaching, or threshold selection E3MC-M□11/-M□41 Channel selection, remote teaching, or threshold selection		
Answer-back output (mode B only)	Load current: 100 mA max. NPN open collector output with a residual voltage of 1.2 V max. E3MC-(M)A11/-(M)X11/-(M)Y11 PNP open collector output with a residual voltage of 2.0 V max. E3MC-(M)A41/-(M)X41/-(M)Y41		
External synchronous input	Response time: 1 ms max. (The 4-output model is not available in mode B.)		
Color detection	4 banks selectable (either by bank selection input or by using the SELECT button) Input response time for bank selection: 50 ms max.		
Indicator	Operation indicator (orange LED), 4-level bank indicator (green LED, See Note 3.), 7-level threshold indicator (red LED), 8-level detection indicator (green LED), and four channel indicators (orange LED, See Note 4.)		
Protection	Protection from reversed power supply connection and output short-circuit		
Ambient light immunity	Incandescent lamp: Illumination on optical spot: 3,000 lx max. Sunlight: Illumination on optical spot: 10,000 lx max.		
Ambient temperature	Operating: -25°C to 55°C (-13°F to 131°F) with no icing		
Relative humidity	Operating: 35% to 85% (with no condensation)		
Permissible fiber bending radius	---	10 mm min.	Varies with the type of selected fiber (see specific fiber specifications)
Insulation resistance	20 MΩ min. (at 500 VDC)		
Dielectric strength	1,000 VAC, 50/60 Hz for 1 min		
Vibration resistance	10 to 55 Hz, 1.0-mm double amplitude or 150 m/s ² (approx. 15G) for 2 hrs each in X, Y, and Z axis. 0.75-mm double amplitude or 100 m/s ² (10G) when using a Mounting Bracket.		
Shock resistance	500 m/s ² (approx. 50G) for 3 times each in X, Y, and Z axis. 300 m/s ² (30G) when using a Mounting Bracket.		
Enclosure rating	IEC IP66 (with protective cover in place)		
Material	Case: Zinc die-cast Cover: PES	Case: Zinc die-cast Cover: PES Fiber head: ABS	Case: Zinc die-cast Cover: PES
Weight (with 2-m cable)	Approx. 350 g	Approx. 400 g	Approx. 350 g

Note: 1. Refer to *Remote Teaching*.

2. **Definition of Sensing Distance**

Refer to the following table and the diagram to the right.

Item	E3MC-(M)A□□	E3MC-(M)X□□
Color discrimination mode	Mode C	
Response time	Standard mode	
Tolerance (θ)	15°	10°
Detectable colors	11 standard colors	

3. 1-output models only: E3MC-A□□/X□□/Y□□

4. 4-output models only: E3MC-MA□□/MX□□/MY□□

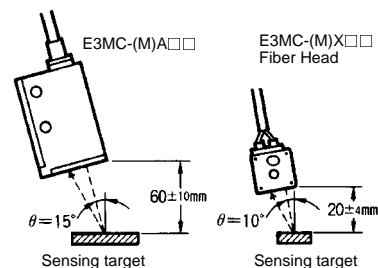

Application Examples

■ DETECTING INTERNAL YELLOW RESIN PLATES OF A BATTERY



■ PATTERN POSITIONING

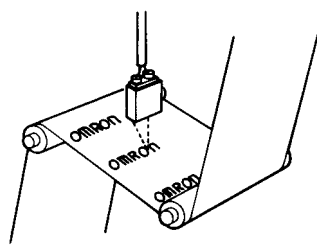

■ DISCRIMINATING FRONT AND BACK SIDES OF OBJECTS

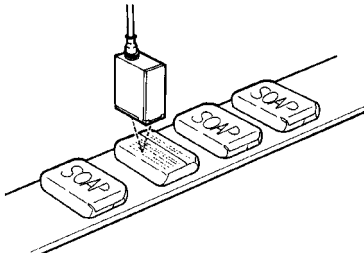

■ DETECTING LABELS

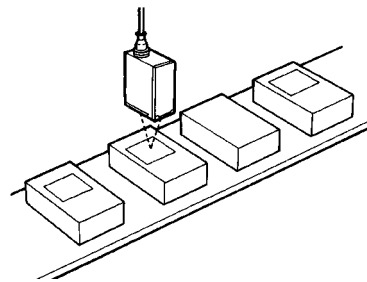

■ STANDARD SENSING OBJECTS

Color (11 standard colors)	Munsell color notation (See Note.)
White	N9.5
Red	4R 4.5/12.0
Yellow/red	4YR 6.0/11.5
Yellow	5Y 8.5/11.0
Yellow/green	3GY 6.5/10.0
Green	3G 6.5/9.0
Blue/green	5BG 4.5/10.0
Blue	3PB 5.0/10.0
Blue/purple	9PB 5.0/10.0
Purple	7P 5.0/10.0
Red/purple	6RP 4.5/12.5

Note: Munsell Color Notation: A color classification system that assigns three values to each color: Hue, Value, and Chroma. System was developed by Albert Munsell and published in 1905.

Engineering Data

■ SENSING DISTANCE VS. COLOR DIFFERENCES (TYPICAL)

E3MC-(M)A□□

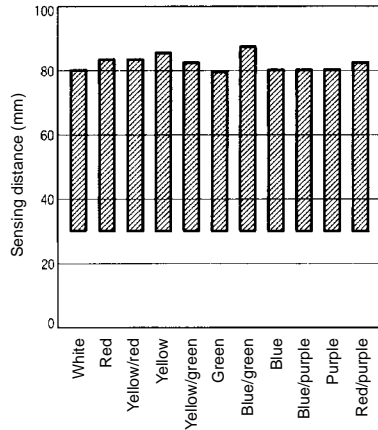

■ ANGLE CHARACTERISTICS (TYPICAL)

E3MC-(M)A□□ (X Direction)

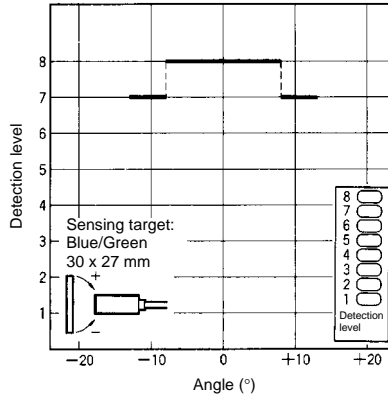

■ ANGLE CHARACTERISTICS (WHEN TEACHING AT AN INCLINATION OF 15°)

E3MC-(M)A□□ (Y Direction)

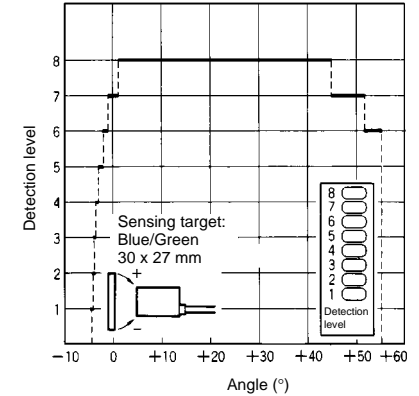

■ SENSING DISTANCE VS. COLOR DIFFERENCES (TYPICAL)

E3MC-(M)X□□

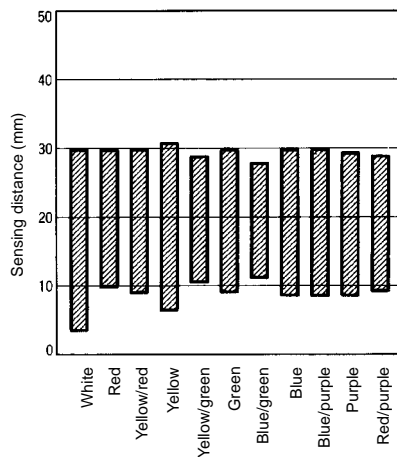

■ ANGLE CHARACTERISTICS (TYPICAL)

E3MC-(M)X□□ (X Direction)

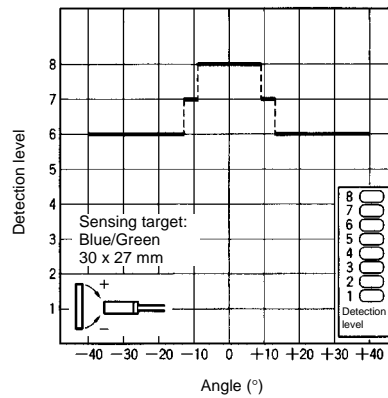

■ ANGLE CHARACTERISTICS (WHEN TEACHING AT AN INCLINATION OF 10°)

E3MC-(M)X□□ (Y Direction)

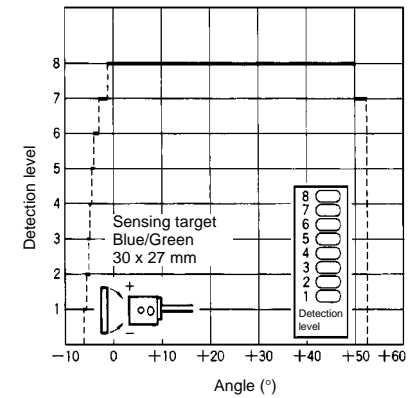

■ GENERAL-PURPOSE FIBER-OPTIC TYPE

Recommended Fiber: Diffuse Fiber-Optic

The following optical fibers are recommended for use with the E3MC-(M)Y□□.

Part number	Sensing distance (See Note 1.)
E32-DC200	5 mm
E32-CC200 (See Note 2.)	5 mm
E32-D32L (See Note 3.)	4.5 mm
E32-D11L	5 mm

- Note: 1. The E3MC-(M)Y□□ discriminates eleven colors at the above distances. For a typical example, nine colors are discriminated at a sensing distance of 12 mm.
2. The fiber to be inserted into the emitter is indicated with white lines. Insert the amplifier fiber into the lower emitter section.
3. The fiber to be inserted into the emitter is indicated with dotted yellow lines. Insert the amplifier fiber into the lower emitter section.

Sensing Distance of a Diffuse Fiber

E32-DC200, etc.

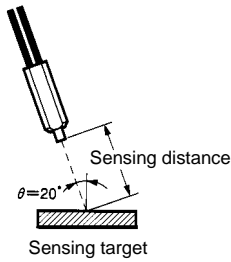

RECOMMENDED FIBER: THROUGH-BEAM FIBER

The following optical fibers are recommended for use with the E3MC-(M)Y□□.

Part number	Sensing range (See Note.)
E32-TC200	30 mm
E32-T11L	60 mm
E32-T16	200 mm
E32-T17L	1.1 m

Note: The E3MC-(M)Y□□ discriminates red, blue, and yellow films at the above distances.

AVAILABLE OPTICAL FIBERS

In addition to the previous recommended optical fibers, the following optical fibers are available for the E3MC-(M)Y□□. Refer to the E3X-NH Datasheet (E258-E1) for the following optical fibers in detail. Optical fibers other than the following are not available.

Part number	Sensing method	Remarks
E32-TC200A	Through-beam	Not different from the E32-TC200 in optical characteristics.
E32-TC200B		
E32-TC200C		
E32-TC200D		
E32-T12L		
E32-T14	---	Not different from the E32-T11L in optical characteristics.
E32-T11		
E32-T11R		
E32-T11R	Through-beam (R1 fiber)	---

Part number	Sensing method	Remarks
E32-DC200B	Diffuse	Not different from the E32-DC200 in optical characteristics.
E32-DC200C		
E32-DC200D		
E32-D12		
E32-D11		
E32-D11R	Through-beam (R1 fiber)	---
E32-G14	Groove	---

OPERATING RANGE CHARACTERISTICS (TYPICAL)

E32-DC200

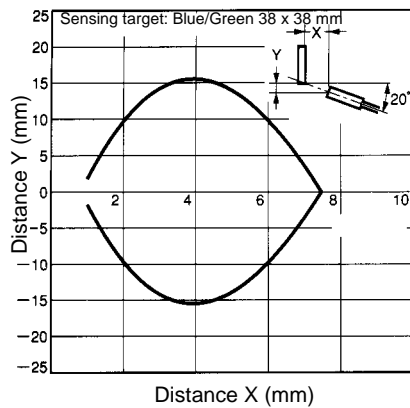

E32-CC200

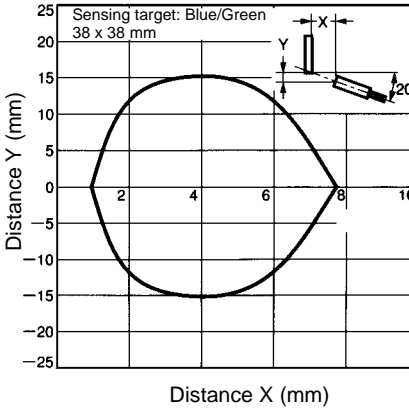

E32-D32L

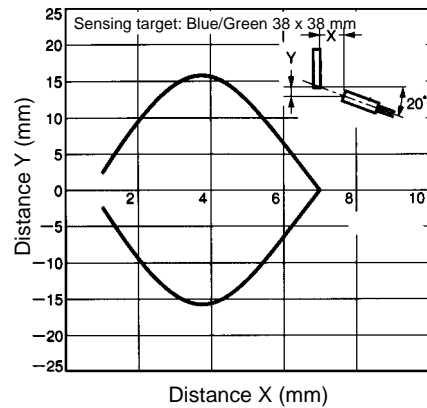

E32-D11L

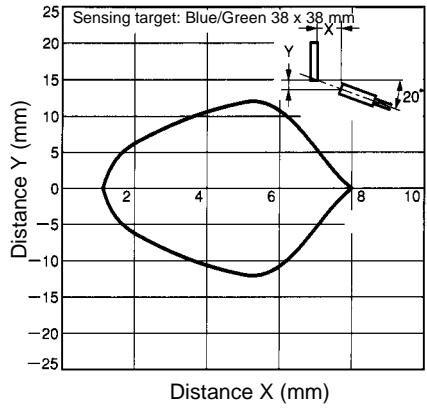

Sensing Target:
Red, Blue, and Yellow Films

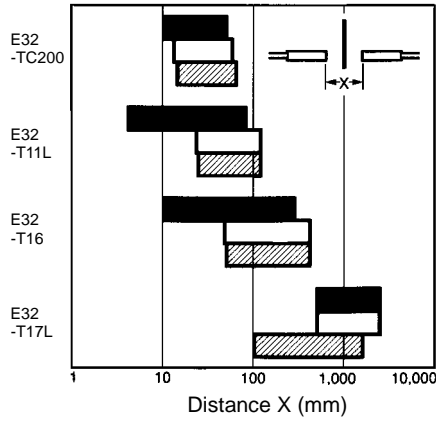

- Sensing target: Film in Red (rosco/UX, scarlet)
- Sensing target: Film in Yellow (rosco/UX, straw)
- Sensing target: Film in Blue (rosco/UX, skyblue)

The above color films are made by the rosco company.

■ CHROMATIC SENSITIVITY (TYPICAL)

Sensing Target: Bottle
E32-T17L

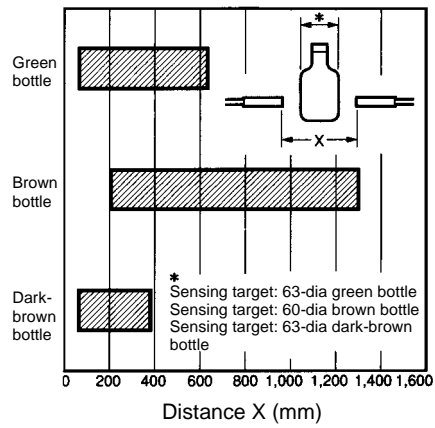

Nomenclature

■ E3MC ALL MODELS

Operation Indicator (Orange)
Illuminated when output is ON. Under mode B (single-output models), the indicator will be illuminated when mode B is active or when the mode selector is set to TEACH.

Bank Indicator (Green)
1-channel models. Displays selected bank.

Channel Indicator (Orange)
4-channel models. Displays selected channels. Illuminated when the output of each channel is ON.

TEACH Button
Stores target color. On 4-channel models, used to check the number of channels that are indicated by both the operation indicator and channel indicator.

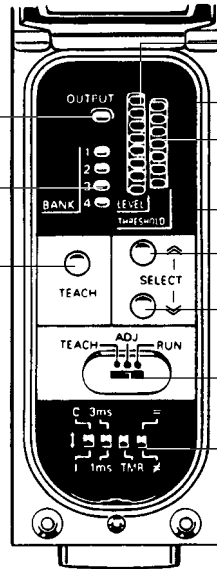

Detection Level Indicator (Green)
Displays similarity level between registered and detectable colors.

Tolerance #1

Threshold Indicator (Red)
Displays threshold level.

Tolerance #7

SELECT UP Button, SELECT DOWN Button
Bank selection
Threshold adjustment

Mode Selector
Selects TEACH, ADJ, or RUN mode.

Function Switch (see details below)
Color discrimination mode selection
Response time selection
OFF-delay timer setting
Conformity/Non-conformity output selection
(See glossary—Light/Dark Operate)

Function Switch

The following settings are possible in RUN or ADJ mode. (Each pin of the function switch is factory-set to the upper position.)

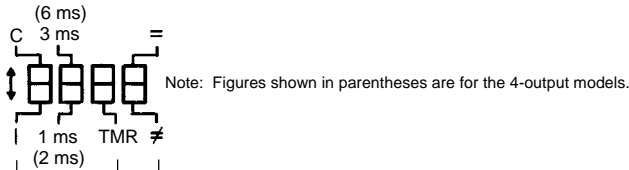

Color Discrimination Mode Selection (Mode C is Recommended for Normal Applications)

- Mode C: Color discrimination is performed according to R (red), G (green), and B (blue) ratio of the reflection light even if the sensing objects fluctuate up and down within the rated sensing range.
- Mode I: Color discrimination is performed according to RGB light intensity of reflection light. This mode ensures more delicate color discrimination than mode C.

Response Time Selection

- 3 ms (6 ms): The E3MC can stably detect minute differences of color. Set the response time to 3 ms for usual applications.
- 1 ms (2 ms): The E3MC will be in quick-response operation. Set the response time to 1 ms if high-speed response is required.

OFF-delay Timer Setting

- : No OFF-delay timer is set.
- TMR: A 40-ms OFF-delay timer is set for control output.

Conformity/Non-conformity Output (See glossary—Light/Dark Operate)

- =: Output is ON when the detected color coincides with the registered color.
- ≠: Output is ON when the detected color does not coincide with the registered color.

Operation

■ OUTPUT CIRCUITS

Connector Pin Arrangement For All Models



Note: Pin 8 is not used.

E3MC-□11 with NPN Output (1-output Models)

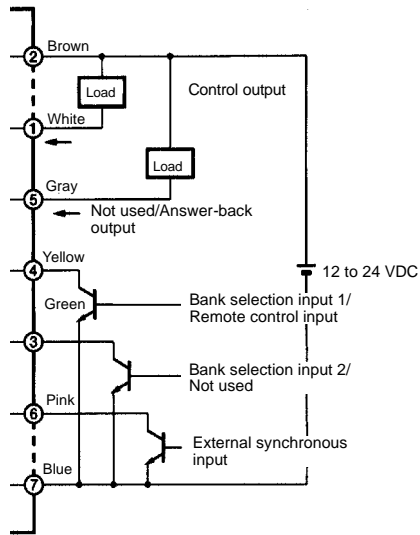

E3MC-M□11 with NPN Output (4-output Models)

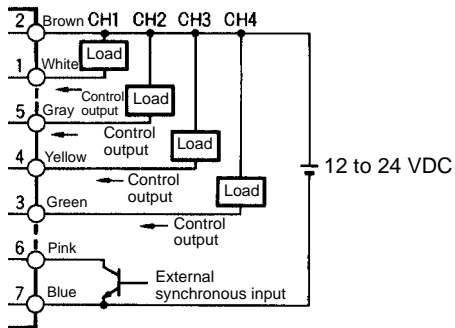

E3MC-□41 with PNP Output (1-output Models)

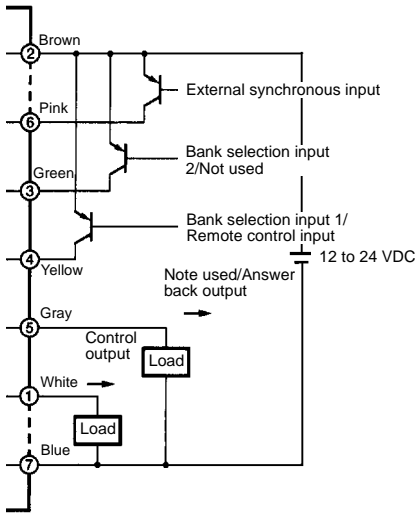

E3MC-M□41 with PNP Output (4-output Models)

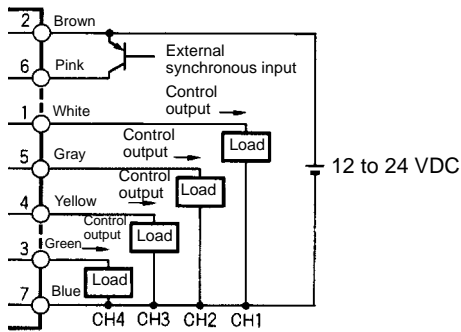

■ SETTINGS

E3MC-A□□/E3MC-X□□ -- Single-Output Models

1. Bank Selection

Set the Mode Selector to the TEACH mode, and then select the BANK using the SELECT button.

To select banks 1 - 4, first slide 3-position switch to "TEACH."

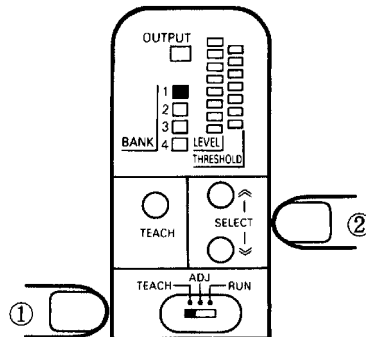

Then press SELECT buttons, scrolling through banks 1 - 4.

2. Color Registration

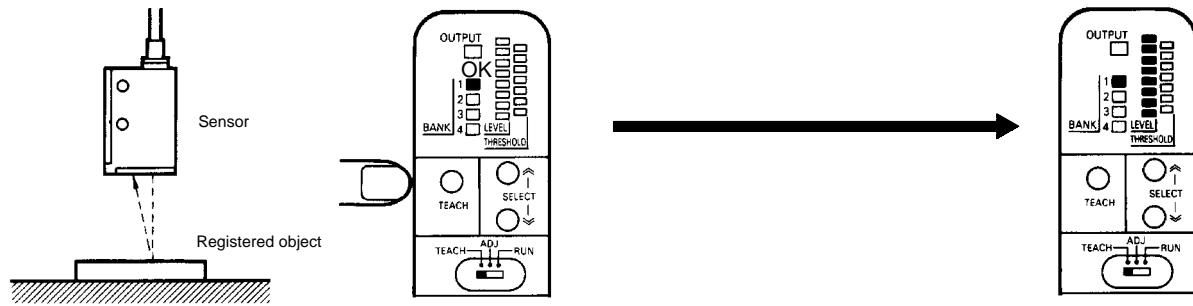

Position the registered object at the detection point and press the TEACH button.

No Good

All the red threshold indicators will flash if the E3MC receives excessive light.

All the detection level indicators are illuminated.

3. Threshold Adjustment (If Required)

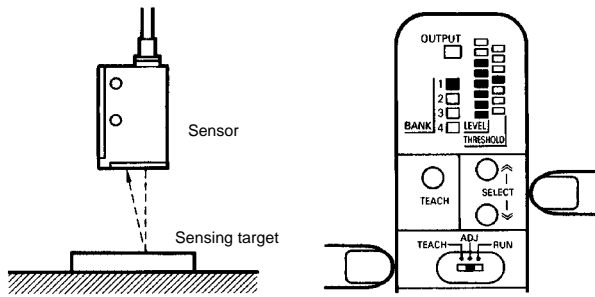

Press the SELECT button in ADJ mode with or without the object to be detected positioned at the detection point.

- Detection Level and Tolerance

As the detected color becomes closer to the registered color, the number of illuminated detection level indicators increases. When the E3MC is in conforming output mode, the control output of the E3MC will be ON if the detection level exceeds the threshold level and OFF if the detection level does not exceed the threshold level.

Set the threshold to a higher level for highly-precise color discrimination and to a lower level to ignore minor tint differences or dirt retention.

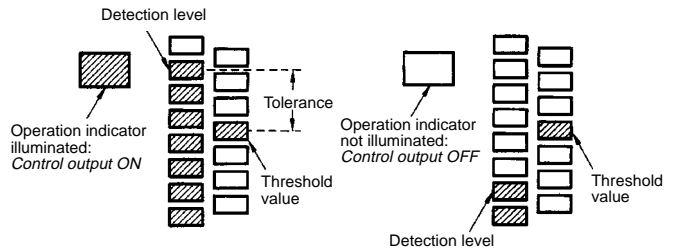

4. Operation

Detection operation is performed in RUN mode. ON/OFF status of each bank is displayed on the bank indicators.

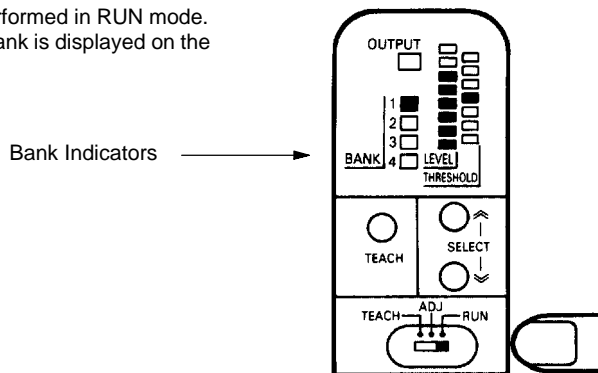

E3MC-MA□□/ E3MC-MX□□ -- 4-Output Models

1. Channel Selection

Set the Mode Selector to the TEACH mode.
Then select the channel using the SELECT button.

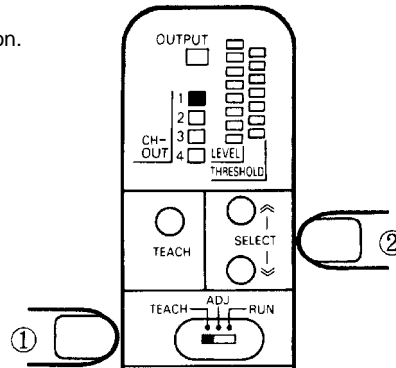

2. Color Registration

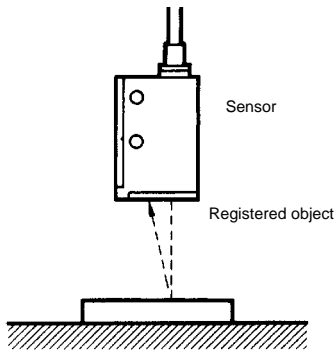

Position the registered object at the detection point and press the TEACH button.

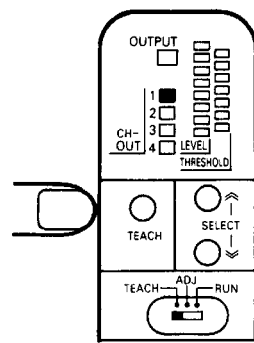

No Good



All the red threshold indicators will flash if registration has not been completed.

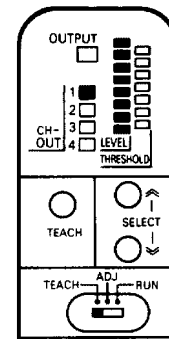

OK



All the detection level indicators are illuminated.

3. Threshold Adjustment (If Required)

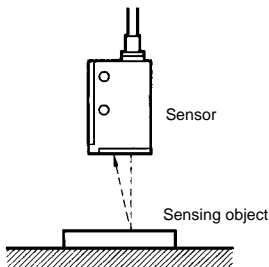

Press the SELECT button in ADJ mode with or without the object to be detected positioned at the detection point. The channel selected in the TEACH mode or RUN mode will become the channel for the ADJ mode.

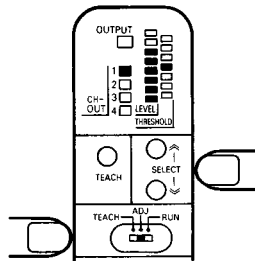

• Detection Level and Tolerance

As the detected color becomes closer to the registered color, the number of illuminated detection level indicators increases. When the E3MC is in conforming output mode, the control output will be ON if the detection level exceeds the threshold level and OFF if the detection level does not exceed the threshold level.

Set the threshold to a higher level for highly-precise color discrimination and to a lower level to ignore minor tint differences or dirt accumulation.

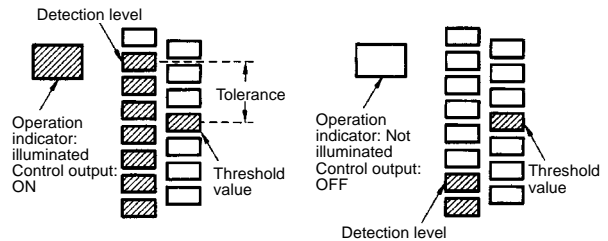

4. Operation

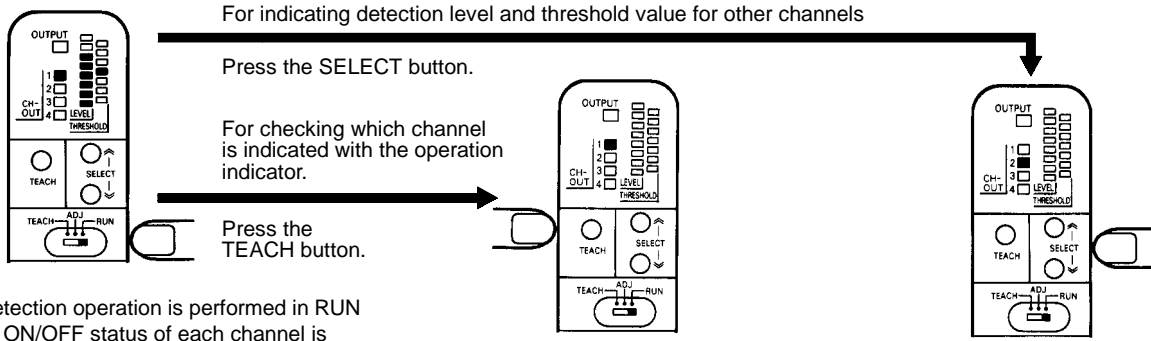

The detection operation is performed in RUN mode. ON/OFF status of each channel is displayed on the channel indicators. Doubly displayed channels (operation indicator and channel indicator) can be checked and selected by pressing the TEACH button and selected by pressing the SELECT button.

Displays the channel whose detection level is currently indicated in the channel indicator for three seconds.

Displays the selected channel for three seconds and indicates detection level and threshold value of the selected channel.

■ DETECTION LEVEL AND INDICATOR

Indicator								
Detection level	1	2	3	4	5	6	7	8

■ TECHNICAL GUIDE

If the E3MC does not detect metal or glossy objects accurately, change the mounting angle of the E3MC so that it will not receive regular reflection light directly reflected from the objects.

The mounting angle of the E3MC-X□□ can be adjusted to approximately 10° with the mounting holes.

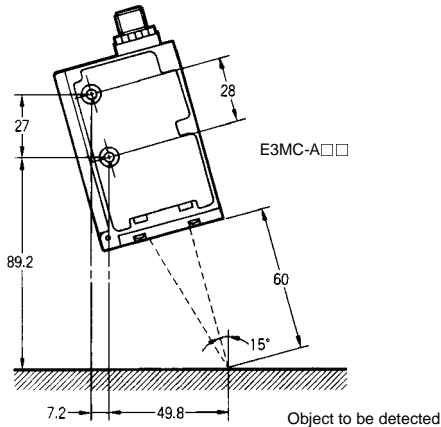
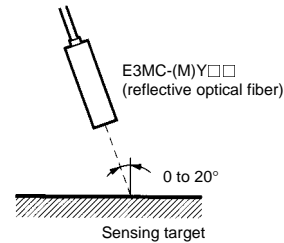
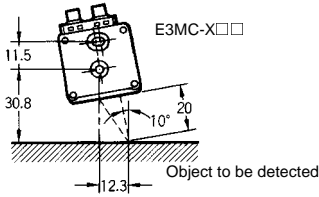

On the other hand, sensing targets such as metal or transparent plastic cases may be detected by allowing regular reflection.

Detection of White, Gray, or Black Objects

When registering white, gray, or black objects, change the color discrimination mode to "Mode I" to achieve a more stable color discrimination.

External Light

The E3MC may malfunction if it directly receives external light interference. Provide a cover to shut-out such external light interference.

Note: To avoid malfunction, provide a cover to shut out direct external light interference to the E3MC.

Adjustment of Sensing Distance of General-purpose Fiber-optic Type

Unlike the E3MC-A or E3MC-X, the E3MC-Y may require adjustment of its sensing distance depending on the reflection rate. This also applies to the through-beam type.

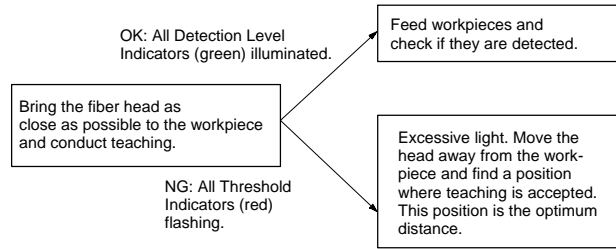

REGISTERED COLOR SELECTION (BANK SELECTION INPUT)

Single-Output Models ONLY (E3MC-A□□/E3MC-X□□/ E3MC-Y□□)

The E3MC in RUN mode offers bank selection with external inputs by combining bank selection input 1 (yellow) and input 2 (green). The selected bank is active when the indicator is illuminated.

NPN (E3MC-A11/-X11/-Y11)

Bank	Input 1	Input 2
1	OPEN	OPEN
2	GND	OPEN
3	OPEN	GND
4	GND	GND

PNP (E3MC-A41/-X41/-Y41)

Bank	Input 1	Input 2
1	OPEN	OPEN
2	Vcc	OPEN
3	OPEN	Vcc
4	Vcc	Vcc

EXTERNAL SYNCHRONOUS INPUT FUNCTION (See Note.)

The measurement results will be directly output to the control output if the input from the external synchronous input terminal (pink) is set to OFF. The output will hold the previous status if the input of the external synchronous input terminal is set to ON. External synchronous input is valid in RUN or ADJ mode.

Condition	NPN (E3MC-□□11)	PNP (E3MC-□□41)
ON (Status on hold)	GND	Vcc
OFF (Result output)	OPEN	OPEN

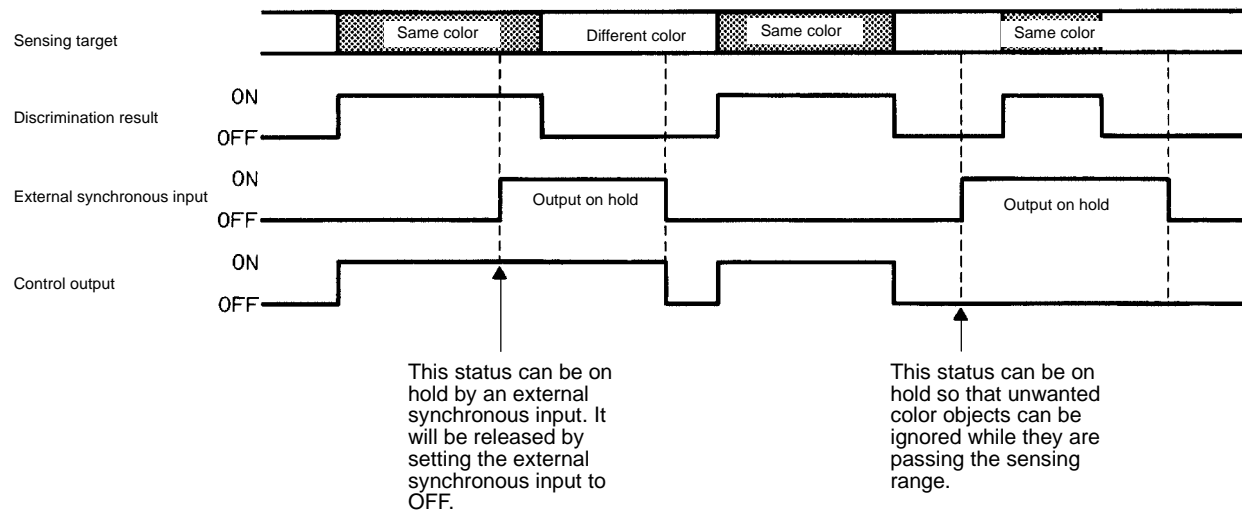

Note: External Synchronous Input: Latches sensor output in existing state when ESI is on. For example, if sensor output is on when ESI is on, the output(s) will remain on until ESI is turned off, regardless of target presence or absence.
 For NPN models, ESI is turned on by connections to 0V.
 For PNP models, ESI is turned on by connections to +V.

REMOTE TEACHING (REMOTE CONTROL FUNCTION)

Mode Setting

When using the remote control function of the Sensor for remote teaching, be sure to set the Sensor to mode B.

Setting Method

Apply power to the Sensor while pressing the SELECT DOWN button and TEACH button together.

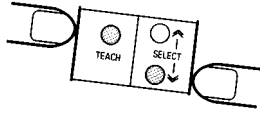

Checking Method

Mode A or B of the E3MC will be displayed for 3 s after mode setting. When the mode selector is set to TEACH, the mode can be checked from the operation indicator. The indicator will be lit when the mode is set to B.

Mode A:
Operation indicator is OFF.

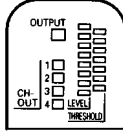

Mode B:
Operation indicator is ON.

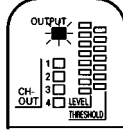

- Note:
- The Sensor is set to mode A before shipping.
 - The current mode selected does not change after the Sensor is turned OFF.
 - The remote control function is available in RUN mode and ADJ mode only.
 - The E3MC-M□ has three outputs in mode B and no external synchronous input will be accepted.
 - The same switching procedure can be used for changing to mode A.

Remote Teaching Method

Function 1: Remote teaching with manual input through an external connection

Short-circuit the remote control input for 1.5 s or more to either of the following terminals according to the E3MC model.

NPN type (E3MC-□□11)	Short-circuit to GND (blue) terminal.
PNP type (E3MC-□□41)	Short-circuit to Vcc (Brown) terminal.

Function 2: Remote control of teaching and bank selection through the PLC or PC

Input one of the following signals as a remote control input. There will be an answer-back output for 0.3 s if the signal is correctly received.

No.	Control signal	E3MC-□	E3MC-M□□
1		Bank 1 selected.	Channel 1 selected.
2		Bank 2 selected.	Channel 2 selected.
3		Bank 3 selected.	Channel 3 selected.
4		Bank 4 selected.	Not used.
5		Teaching of selected bank.	Teaching of selected channel.

The following is an example of a timing chart of teaching after bank selection.

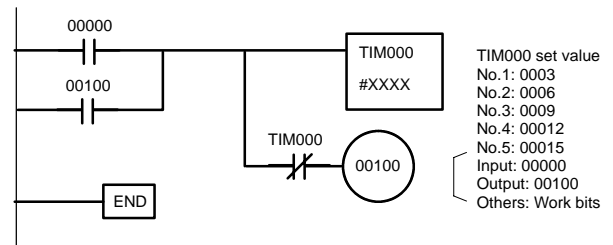

The following is an example of a timing chart of teaching after bank selection.

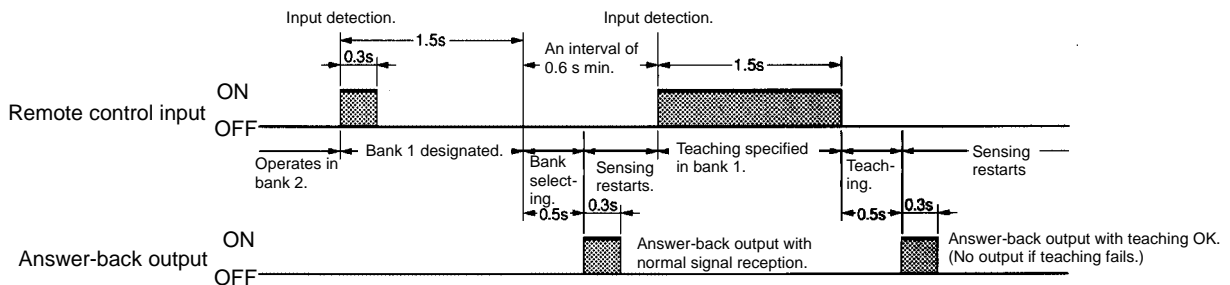

Function 3: Remote control of threshold adjustments through the PLC or PC

Input either one of the following signals as remote control input. There will be an answer-back output for 0.3 s if the signal is correctly accepted.

No.	Control signal	All E3MC models
6		Threshold 1 selected.
7		Threshold 2 selected.
8		Threshold 3 selected.
9		Threshold 4 selected.
10		Threshold 5 selected.
11		Threshold 6 selected.
12		Threshold 7 selected.

Threshold and Display

- Threshold 1
- Threshold 2
- Threshold 3
- Threshold 4
- Threshold 5
- Threshold 6
- Threshold 7

The following is an example of ladder programming for setting control signals. Full control of the E3MC is possible using this function.

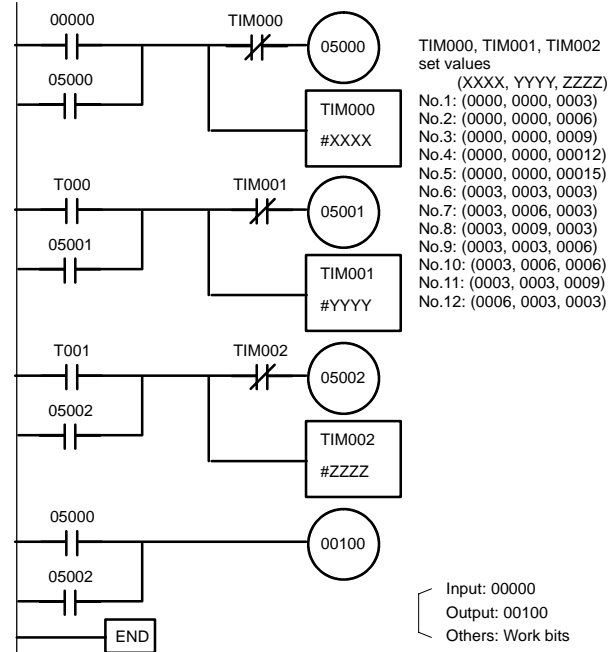

- Note:
1. The permissible error of each signal pulse is ± 0.1 s max.
 2. A minimum interval of 0.6 s is required between signals.
 3. Threshold 4 is set after teaching.

Dimensions

Unit: mm (inch)

■ RGB COLOR SENSORS

E3MC-A□□□
E3MC-MA□□□

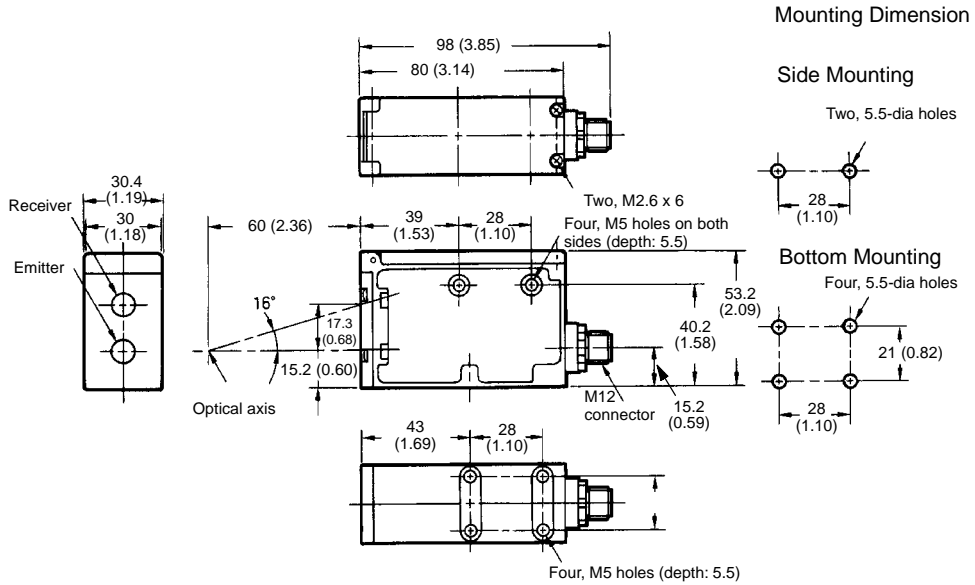
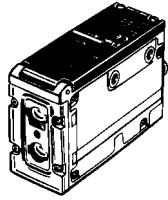

E3MC-X□□□
E3MC-MX□□□

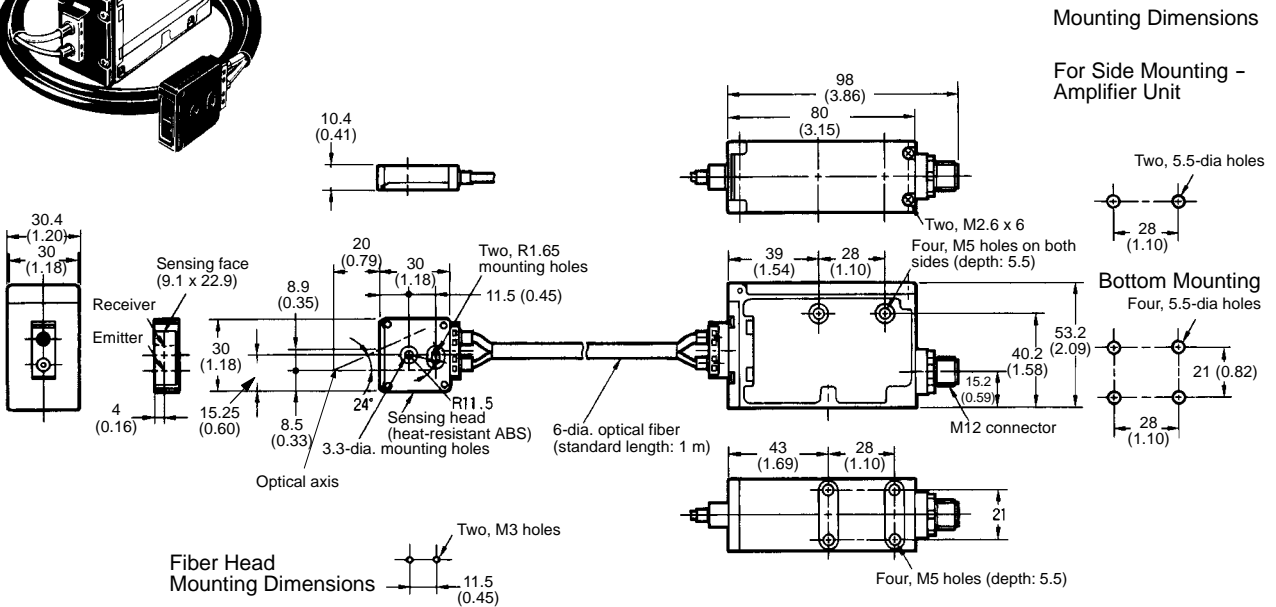
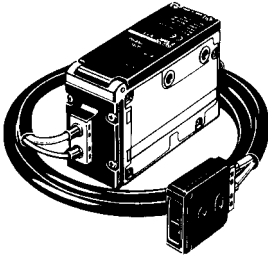

Unit: mm (inch)

E3MC-Y□□
E3MC-MY□□

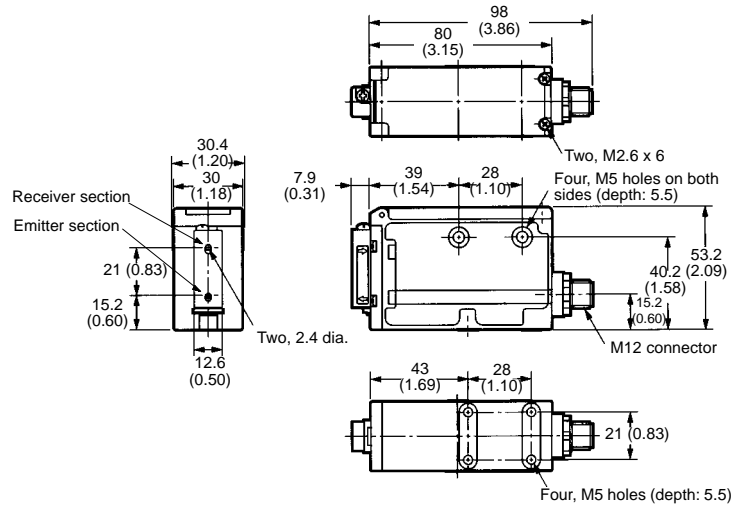
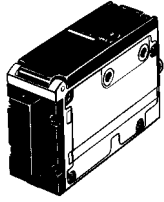

Mounting Dimensions (Amplifier Unit)

Side Mounting

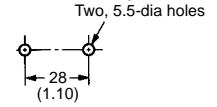

Bottom Mounting

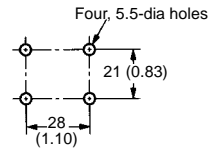

■ ACCESSORIES

Sensor I/O Connector
E39-C1 2M
E39-C1 5M

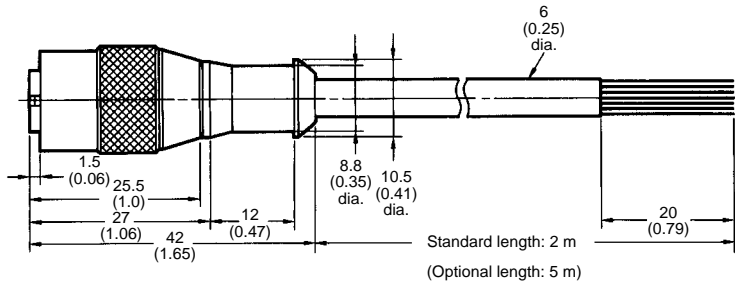

E39-L114 DIN Rail Side-Mounting Brackets

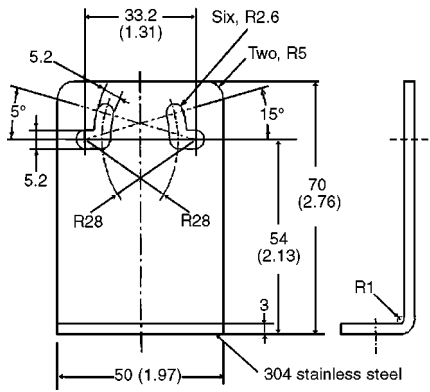

Mounting Holes

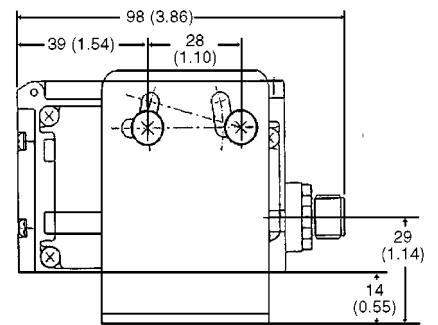
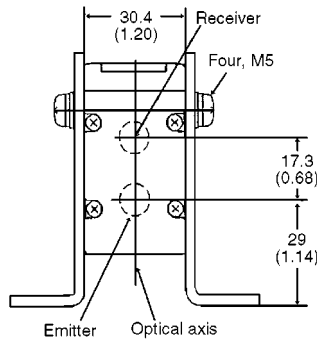
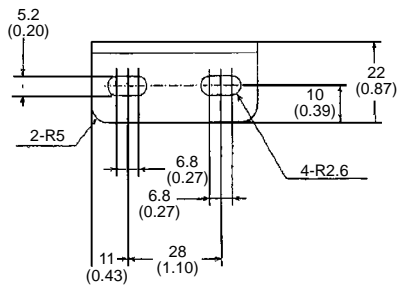
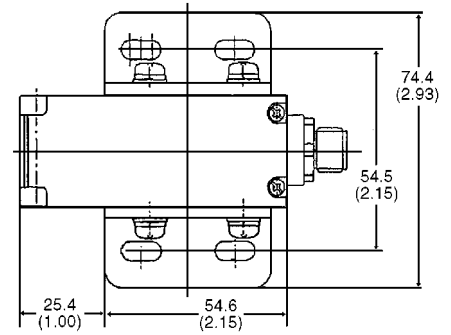
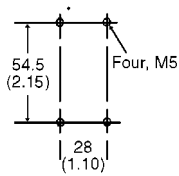

E39-L115 DIN Rail Mounting Bracket

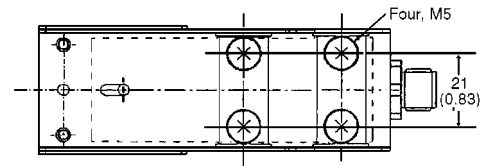
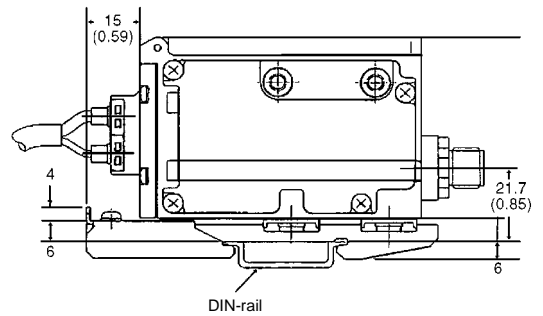
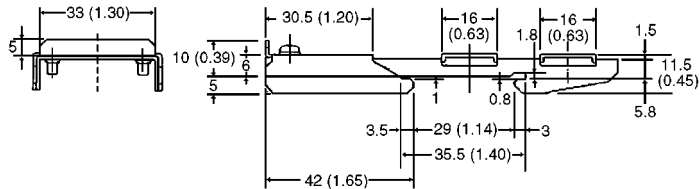
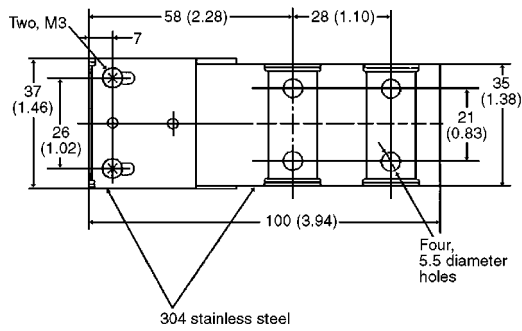

Installation

■ PLUG

Sensor I/O Connector
E39-C1 2M
E39-C1 5M

Internal Wiring

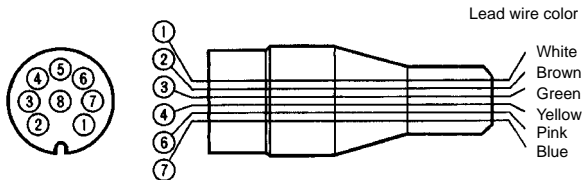

Connection

Pin no.	Wire color	Purpose	
		E3MC-□11 or E3MC-□41	E3MC-M□11 or E3MC-M□41
1	White	Output	Output 1
2	Brown	Power supply (+V)	
3	Green	Bank selection input 2	Output 4
4	Yellow	Bank selection input 1	Output 3
5	Gray	---	Output 2
6	Pink	External synchronous input	
7	Blue	Power supply (0V)	

■ FIBER UNIT

Tightening Torque

The Fiber Unit must be tightened to a maximum torque of 0.54 N • m (5.4 kgf • cm or 4.85 in • lbs).

Mounting

When Fiber Units are mounted facing each other, you must adjust the optical axes of the Fiber Units to avoid any mutual interference.

Handling the Fiber Unit

- Do not pull or press the Fiber Unit.
- Do not bend the Fiber Unit beyond the permissible bending radius provided in Ratings/Characteristics.
- Do not bend the edge of the Fiber Unit.
- Do not apply excess force to the Fiber Unit.

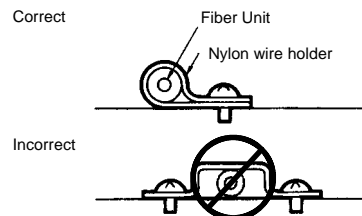
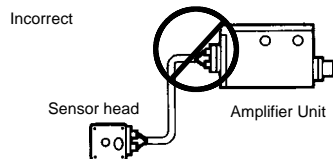
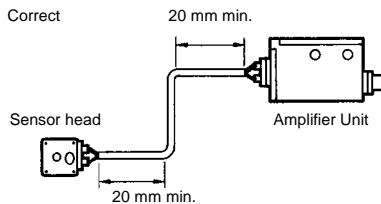

- The Fiber Head could be broken by excessive vibration. To prevent this, use a one-turn loop to absorb vibration, as shown here:

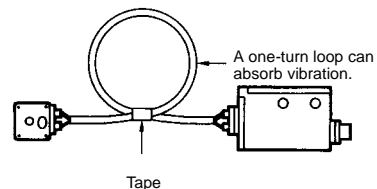

■ AMPLIFIER UNIT

Tightening Torque

The Amplifier Unit must be tightened to a maximum torque of $2.3 \text{ N} \cdot \text{m}$ ($23 \text{ kgf} \cdot \text{cm}$).

Mounting

When Sensors are mounted facing each other, you must adjust the optical axes so that the Sensors will not cause mutual interference.

■ GENERAL-PURPOSE FIBER-OPTIC TYPE

Insertion

The inserted Fiber Unit comes in contact with the internal rubber packing first. Insert the Fiber Unit further until it comes in contact with the innermost end.

Mounting

Tighten the Fiber Unit with a screwdriver to a torque of $0.2 \text{ N} \cdot \text{m}$ ($2 \text{ kgf} \cdot \text{cm}$).

Fibers

Among the recommended fibers, the E32-CC200 and E32-D32L have white or dotted yellow lines on the fiber to be inserted into the emitter. When using the E3MC-(M)Y□□, insert the fiber with the line into the emitter section at the bottom of the amp.

■ FIBER UNIT

Tightening Torque

When mounting the Fiber Unit, refer to the following table and make sure that the tightening torque applied is correct.

Screw-mounting Type

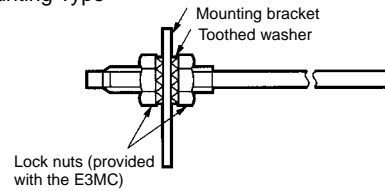

Column Type

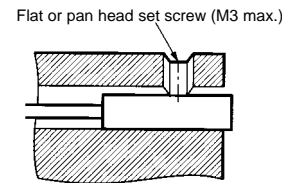

Fiber Unit	Tightening torque
M3 screw	$0.78 \text{ N} \cdot \text{m}$ { $8 \text{ kgf} \cdot \text{cm}$ } max.
M4 screw	
M6 screw	$0.98 \text{ N} \cdot \text{m}$ { $10 \text{ kgf} \cdot \text{cm}$ } max.
2-dia column	$0.29 \text{ N} \cdot \text{m}$ { $3 \text{ kgf} \cdot \text{cm}$ } max.
3-dia column	$0.29 \text{ N} \cdot \text{m}$ { $3 \text{ kgf} \cdot \text{cm}$ } max.
E32-T16	$0.49 \text{ N} \cdot \text{m}$ { $5 \text{ kgf} \cdot \text{cm}$ } max.

Make sure that the size of the wrench applied to the nut is correct.

Fiber Cutting

Insert the fiber into one of the insertion holes of the Cutting Tool to cut the fiber to the desired length.

Press down the blade of the Cutting Tool to cut the fiber in a single stroke. Do not stop the Cutting Tool midway.

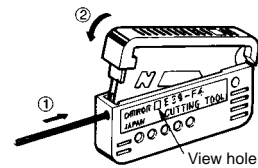

Each insertion hole can be used only once. Do not use it again, or the fiber may not be cut properly and the sensing distance may decrease.

■ DIN-RAIL MOUNTING/REMOVAL WITH THE E39-L115

Mounting

1. Attach the E39-L115 Mounting Bracket to the E3MC with four M5 screws.

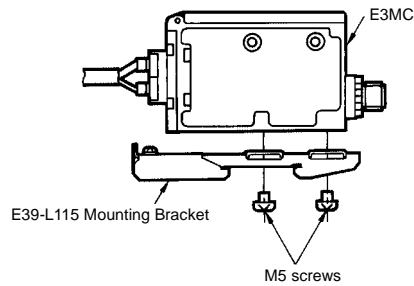

2. When mounting the E3MC with the E39-L115, loosen the M3 screw of the E39-L115 and slide part A in the direction indicated by arrow (1) as shown in the following illustration.

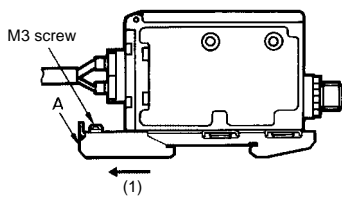

3. Mount part (2) to the DIN rail.

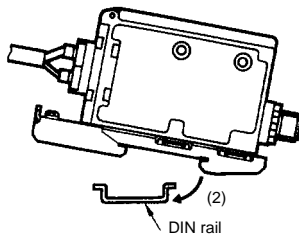

4. Press the E3MC in the direction indicated by arrow (3) and slide part A in the direction indicated by arrow (4) as shown in the following illustration until the E39-L115 correctly engages with the DIN rail.

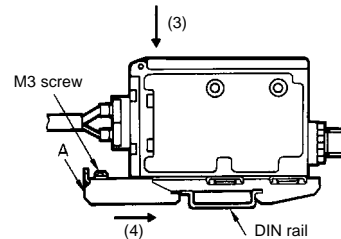

5. Tighten the M3 screw of the E39-L115 to secure the E39-L115.

Removal

Loosen the M3 screw of the E39-L115, press the E3MC in the direction indicated by arrow (5) and slide part A in the direction indicated by arrow (6). Then lift the E3MC up in the direction indicated by arrow (7) to remove the E3MC with the E39-L115.

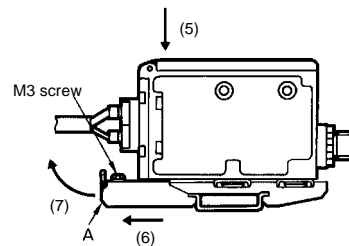

Terms

- **Color Registration**
Detection of a special mark on packaging material referred to as the Registration Mark. This mark is aligned with the printed pattern on the wrapping material and allows proper cut-off of the packaging material so that printed images appear in the correct location on the package.
- **Conformity/Non-conformity**
In the E3MC Color Sensor, term used to indicate when the target color matches a reference color stored in the memory bank(s). A match is "conformity," and a mismatch is "non-conformity."
- **D.O.**
See Dark Operate.
- **Dark Operate**
Operating mode where the output is turned on (transistor becomes conducting, or relay coil is energized) when light is NOT received. In the E3MC Color Sensor, this refers to the mode where the output turns on when the target color does NOT match (non-conformity) the reference color stored in the memory bank.
- **Diffuse Reflective**
Sensor configuration with the emitter and receiver located in the same housing. Sensing of target is based on reflection of light from the target itself (rather than a retroreflector).
- **Excess Gain**
See Stability Indicator.
- **External Synchronous Input**
In the E3MC Color Sensor, an input that allows "latching" of the output when the input is taken high, preventing a change of state until the input is taken low.
- **IEC**
International Electrotechnical Commission.
- **Interference Protection**
See Mutual Interference Protection.
- **IP**
International Protection; an international standard scale for enclosure ratings (sealing).
- **IP66**
Approximately NEMA 4, 4X, "heavy seas" test; the item is subjected to a stream of water from a 1/2" nozzle with 14psi pressure at a distance of 1.5 meter. Water must not enter the item.
- **IP67**
Approximately NEMA 6, "immersion" test; the item is immersed under 1 meter of water for 30 minutes, with no water entry.
- **kgf**
Kilogram Force.
- **kgf • cm**
Kilogram-force centimeters, measure of torque;
1 kgf • cm = 10.4 in • lb.
- **Lensed effect**
Optical phenomenon where light passing through a transparent object (bottle, for instance) is focused in the same manner as a lens. If the lens effect is "converging," the light intensity may be increased significantly. When sensing the presence of an object due to the attenuation of light passing through that object, the lens effect may cause a failure to detect the object. The light intensity may not be reduced due to the "lens" effect of concentrating the light beam.
- **L.O.**
See Light Operate.
- **Light Operate**
Operating mode where the output is turned on (transistor conducts, or relay coil is energized) when light is received. In the E3MC Color Sensor, refers to the mode where the output turns on when the target color matches (conforms) to the reference color stored in the memory bank.
- **Mutual Inference Protection**
Circuitry that allows the sensor to detect and compensate for interfering signals that may be emanating from sources within its sensing range. Sensor can then operate normally, ignoring the interfering signal(s).
- **nm**
Nanometer; a measure of length, 10⁻⁹ meters, 3.937 x 10⁻⁸ inches.
- **NEMA**
National Electrical Manufacturer's Association; industrial trade organization that publishes testing standards, including enclosure ratings.
- **NPN**
Transistor output designed to provide a path to ground for current passing through the load ("sinking"). When the NPN output is on, current can then pass from Positive, through the load, and through the NPN transistor to ground, completing the circuit.
- **PNP**
Transistor output that provides a path to "Plus" for current passing through the load ("sourcing"). When the PNP output is on, current can then pass from Positive, through the PNP transistor, through the load, and to ground, completing the circuit.
- **Reflective Mode**
See Diffuse Reflective.
- **Response time**
Elapsed time from when a target moves into the sensing zone of a sensor to when the output turns on. May also refer to the "turn-off" time. The sum of turn-on and turn-off time is the total cycle time (reciprocal of switching frequency, Hz).
- **Reverse Polarity Protection**
Circuitry that prevents damage to the device if power is incorrectly connected (polarity reversed, DC). The unit may not work while polarity is reversed, but is undamaged, and will work once polarity is corrected.

- **RGB**
Red, green, blue, refers to the triple light source in the E3MC Color Sensor. By sensing the reflection level of each color, the sensor can determine the exact color of the target.
- **Short Circuit Protection**
Circuitry that prevents damage to a device's output if the output is short-circuited. Usually current is monitored, and the output is turned off if current exceeds a predetermined value.
- **Stability Indicator**
Indicator light that shows when a signal being received (such as a light beam) is strong enough for stable operation. Usually this stable operation is expressed as a percentage above the switching threshold of the device.
- **Teach Function**
Circuitry in a sensor that allows sensor threshold to be set with the use of a "teach" input. Switching threshold is set when the teach input is actuated, and it is based on signal received at the moment of teaching.
- **Through-beam**
Sensor where the emitter and receiver are in separate housings, and arranged facing each other. The target would be detected passing between the emitter and receiver, interrupting the beam.

Reference Information

■ WAVELENGTH

Color	Wavelength
Ultraviolet	below 400 nm
Violet	400-450 nm
Blue	450-500 nm
Green	500-570 nm
Yellow	570-590 nm
Orange	590-610 nm
Red	610-700 nm
Infrared	above 700 nm

■ CONVERSIONS

Length	
1 inch = 25.4 mm	1 mm = 0.3937 inch
Torque	
kgf • cm = 10.4 in • lb	1 in • lb = 0.096 kgf • cm
1 N • m = 8.974 in • lbs	
Mass	
1 gram = 2.205 x 10 ⁻³ lbs	1 lb = 453.6 grams
Force	
1 pound (force) = 4.4482219 Newtons	
1 Newton = 0.2248 lb • force	

Precautions

■ AVOID DAMAGE TO THE E3MC

- Voltage must not exceed the rated voltage of the E3MC.
- When supplying power to the E3MC, make sure that the polarity of the power is correct.
- Do not short-circuit the load connected to the E3MC.

■ INSTALLATION

Power Up Ready

- The E3MC is ready to sense objects 100 ms after the unit is turned ON.
- The 100 ms wait is also required when the E3MC output is controlling other devices.
- If power is supplied to the E3MC and the load independently, be sure to turn ON the E3MC *first*.
- When the E3MC is turned ON or OFF, the operation indicator will be illuminated for an instant, but no control output will be turned ON.

Power Off

- The E3MC may output a single pulse when the control power supply is turned OFF. If the E3MC is connected to a timer or counter, you should supply power to the timer or counter from the same power supply as the E3MC.

Power Supplies

- Power supply must be filtered with 10% MAX ripple (see supply voltage specification).
- When a switching regulator is required, you must connect the FG (frame ground) and G (ground) terminals together, eliminating the switching noise of the regulator to avoid a malfunction.

■ WIRING

Cable

- The cable can be extended up to 100 m, allowing for a cable thickness of 0.3 mm² maximum.
- The cable must not be repeatedly bent.
- Do not pull cables with pulling forces exceeding 50 N (11.24 lb • force).

M12 Metal Connector

- When connecting or disconnecting the cable, first remove the power to the E3MC.
- To avoid damage, tighten the metal connector securely by hand. Do *not* use any tools.
- To ensure that the enclosure rating is maintained (so that water/vibration ratings are assured), the cable connector must be *securely* hand-tightened.

Avoid Damage or Malfunction Due to Induction Noise

- Never run the E3MC Color Sensor cables in the same conduit with power lines or high tension cables.

■ FURTHER INFORMATION

Correcting an EEPROM Error

- An EEPROM error may result if the power supplied to the Sensor fails, or if the Sensor is influenced by static noise. When an EEPROM error occurs, the operation and bank indicators will flash and the buzzer will beep. The remedy is to reprogram and make threshold level settings again.

NOTE: DIMENSIONS SHOWN ARE IN MILLIMETERS. To convert millimeters to inches divide by 25.4.

OMRON[®]
OMRON ELECTRONICS, INC.
One East Commerce Drive
Schaumburg, IL 60173
1-800-55-OMRON

OMRON CANADA, INC.
885 Milner Avenue
Scarborough, Ontario M1B 5V8
416-286-6465