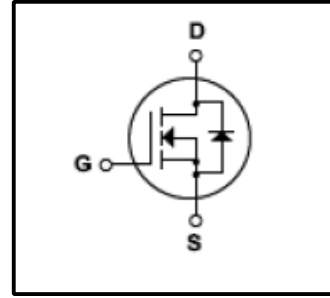
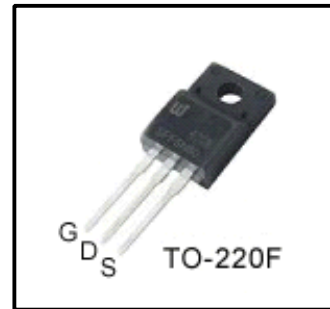

Silicon N-Channel MOSFET
Features

- 12A,650V, $R_{DS(on)}$ (Max0.8 Ω)@ $V_{GS}=10V$
- Ultra-low Gate Charge(Typical 51.7nC)
- Fast Switching Capability
- 100%Avalanche Tested
- Maximum Junction Temperature Range(150 $^{\circ}C$)

General Description

This Power MOSFET is produced using Winsemi's advanced planar stripe, VDMOS technology. This latest technology has been especially designed to minimize on-state resistance, have a high rugged avalanche characteristics. This devices is specially well suited for AC-DCswitching power supplies, DC-DCpower converters, high voltage H-bridge motor drive PWM

Absolute Maximum Ratings

Symbol	Parameter	Value	Units
V_{DSS}	Drain Source Voltage	650	V
I_D	Continuous Drain Current(@ $T_c=25^{\circ}C$)	12	A
	Continuous Drain Current(@ $T_c=100^{\circ}C$)		A
I_{DM}	Drain Current Pulsed (Note1)		A
V_{GS}	Gate to Source Voltage	± 30	V
E_{AS}	Single Pulsed Avalanche Energy (Note 2)	990	mJ
E_{AR}	Repetitive Avalanche Energy (Note 1)	22	mJ
dv/dt	Peak Diode Recovery dv/dt (Note 3)	4.5	V/ns
P_D	Total Power Dissipation(@ $T_c=25^{\circ}C$)	51	W
	Derating Factor above 25 $^{\circ}C$	0.41	W/ $^{\circ}C$
T_J, T_{stg}	Junction and Storage Temperature	-55~150	$^{\circ}C$
T_L	Channel Temperature	300	$^{\circ}C$

Thermal Characteristics

Symbol	Parameter	Value			Units
		Min	Typ	Max	
R_{QJC}	Thermal Resistance, Junction-to-Case	-	-	2.45	$^{\circ}C/W$
R_{QCS}	Thermal Resistance, Case-to-Sink	-	-	-	$^{\circ}C/W$
R_{QJA}	Thermal Resistance, Junction-to-Ambient	-	-	62.5	$^{\circ}C/W$

Electrical Characteristics (Tc = 25° C)

Characteristics	Symbol	Test Condition	Min	Type	Max	Unit	
Gate leakage current	I _{GSS}	V _{GS} = ± 30 V, V _{DS} = 0 V	-	-	± 100	nA	
Gate-source breakdown voltage	V _{(BR)GSS}	I _G = ± 10 μA, V _{DS} = 0 V	± 30	-	-	V	
Drain cut-off current	I _{DSS}	V _{DS} = 650 V, V _{GS} = 0 V	-	-	10	μA	
		V _{DS} = 480 V, Tc = 125°C	-	-	100	μA	
Drain-source breakdown voltage	V _{(BR)DSS}	I _D = 250 μA, V _{GS} = 0 V	650	-	-	V	
Gate threshold voltage	V _{GS(th)}	V _{DS} = 10 V, I _D = 250 μA	2	-	4	V	
Drain-source ON resistance	R _{DS(ON)}	V _{GS} = 10 V, I _D = 6A	-	0.64	0.8	Ω	
Forward Transconductance	g _{fs}	V _{DS} = 50 V, I _D = 6A	-	6.4	-	S	
Input capacitance	C _{iss}	V _{DS} = 25 V,	-	1830	-	pF	
Reverse transfer capacitance	C _{rss}	V _{GS} = 0 V,	-	155	-		
Output capacitance	C _{oss}	f = 1 MHz	-	2.0	-		
Switching time	Rise time	tr	V _{DD} = 325 V, I _D = 12A R _G = 25 Ω (Note4,5)	-	50	-	ns
	Turn-on time	ton		-	49	-	
	Fall time	tf		-	310	-	
	Turn-off time	toff		-	54	-	
Total gate charge (gate-source plus gate-drain)	Q _g	V _{DD} = 520 V, V _{GS} = 10 V,	-	51.7	-	nC	
Gate-source charge	Q _{gs}	I _D = 12 A	-	9.6	-		
Gate-drain ("miller") Charge	Q _{gd}	(Note4,5)	-	18.6	-		

Source-Drain Ratings and Characteristics (Ta = 25° C)

Characteristics	Symbol	Test Condition	Min	Type	Max	Unit
Continuous drain reverse current	I _{DR}	-	-	-	12	A
Pulse drain reverse current	I _{DRP}	-	-	-	48	A
Forward voltage (diode)	V _{DSF}	I _{DR} = 12 A, V _{GS} = 0 V	-	-	1.4	V
Reverse recovery time	t _{rr}	I _{DR} = 12 A, V _{GS} = 0 V,	-	450	-	ns
Reverse recovery charge	Q _{rr}	dI _{DR} / dt = 100 A / μs	-	5.0	-	μC

Note 1.Repeativity rating :pulse width limited by junction temperature

2.L=14mH,I_{AS}=12A,V_{DD}=95V,R_G=25Ω,Starting T_J=25°C

3.I_{SD}≤12A,di/dt≤200A/μs, V_{DD}<BV_{DSS},STARTING T_J=25°C

4.Pulse Test: Pulse Width≤300us,Duty Cycle≤2%

5.Essentially independent of operating temperature.

This transistor is an electrostatic sensitive device

Please handle with caution

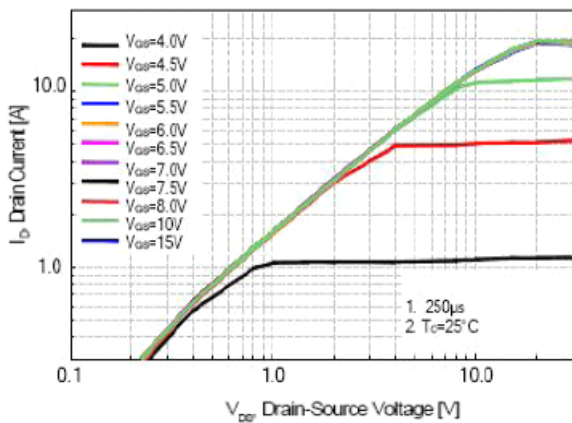

Fig.1 On-State Characteristics

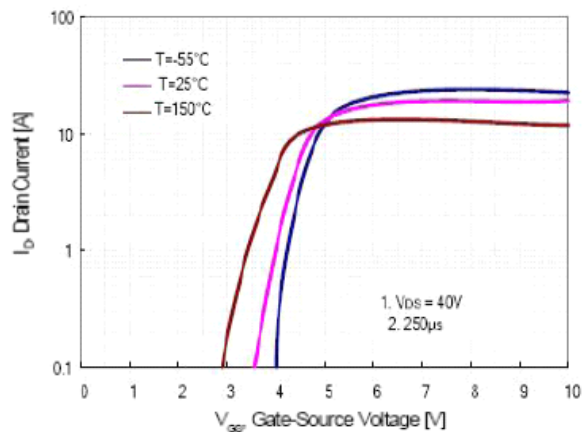

Fig.2 Transfer Current Characteristics

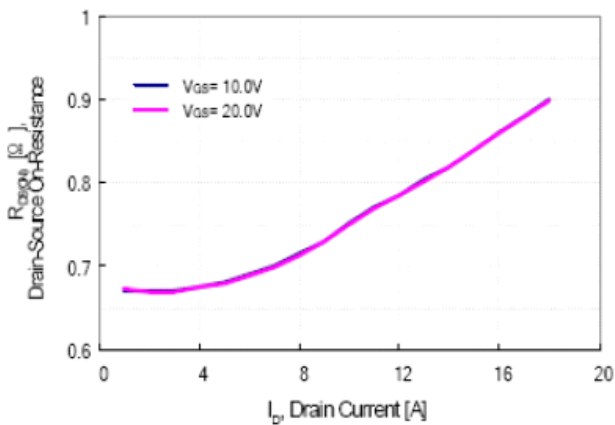

Fig.3 On-Resistance variation vs Drain Current

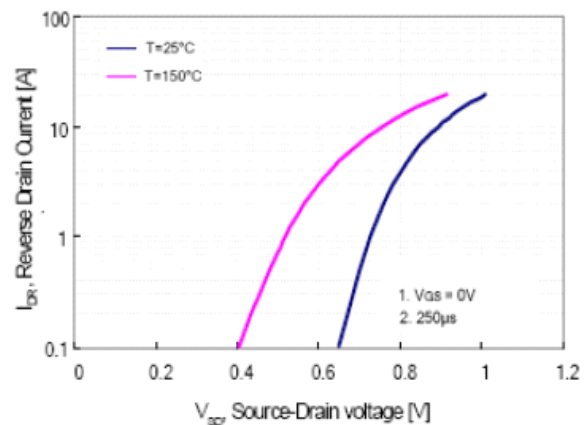

Fig.4 Body Diode Forward Voltage Variation with Source Current and Temperature

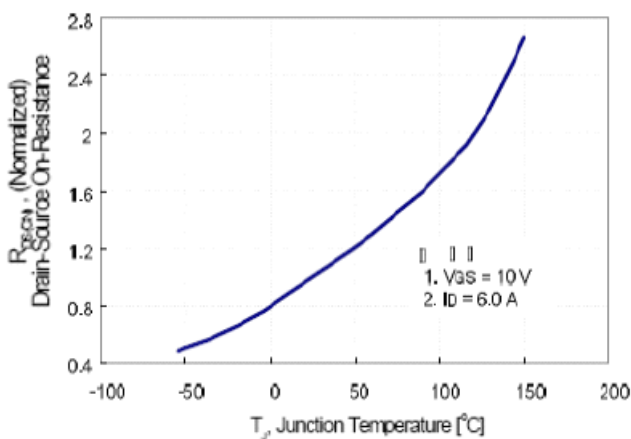

Fig.8 On-Resistance Variation vs Junction Temperature

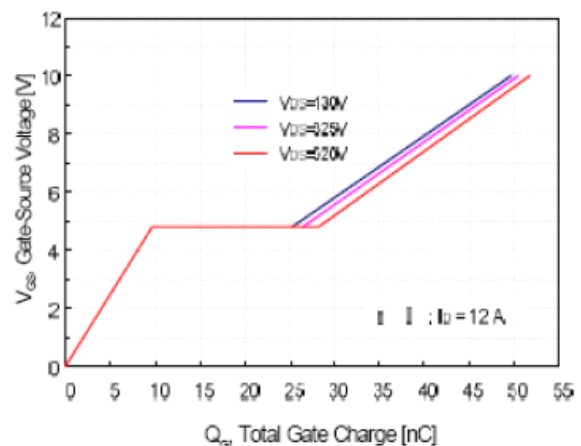

Fig.6 Gate Charge Characteristics

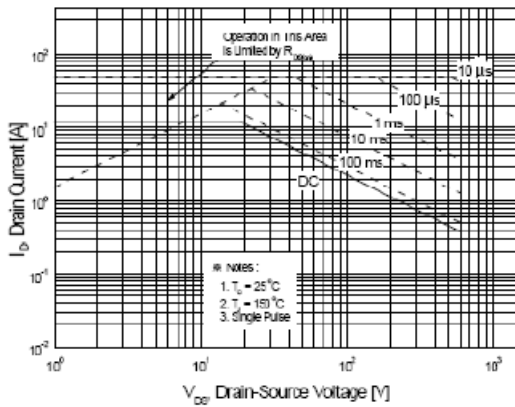

Fig.7 Maximum Safe Operation Area

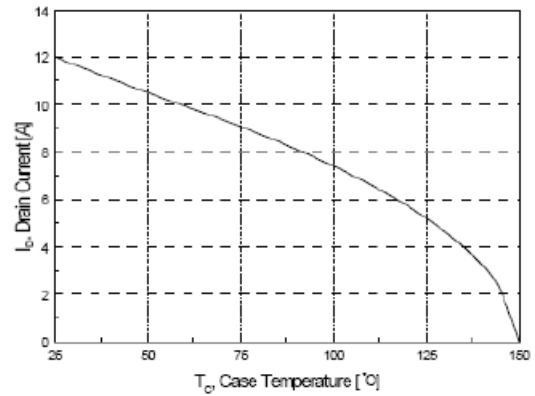

Fig.8 Maximum Drain Current vs Case Temperature

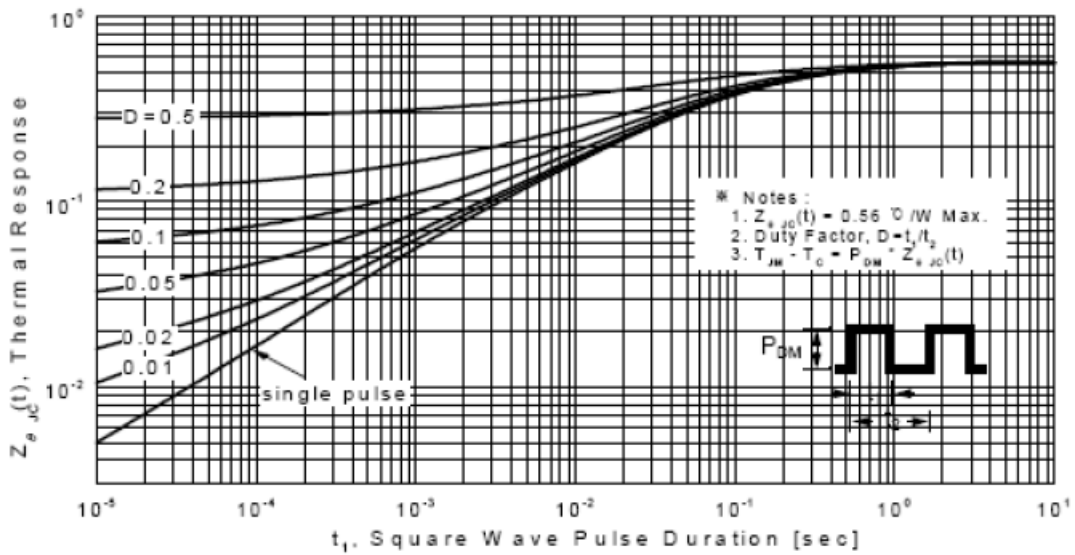

Fig.9 Transient Thermal Response curve

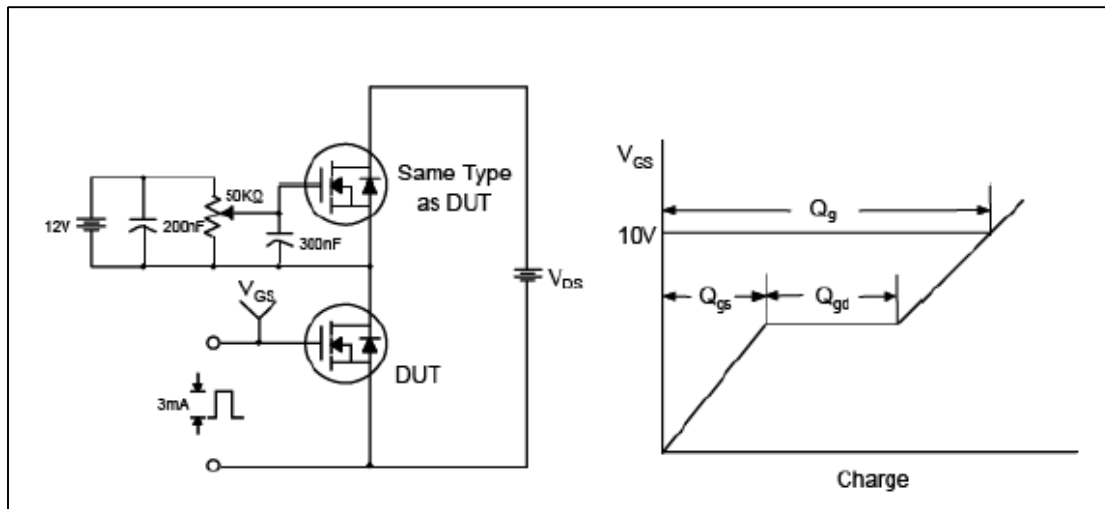

Fig.10 Gate Test circuit & Waveform

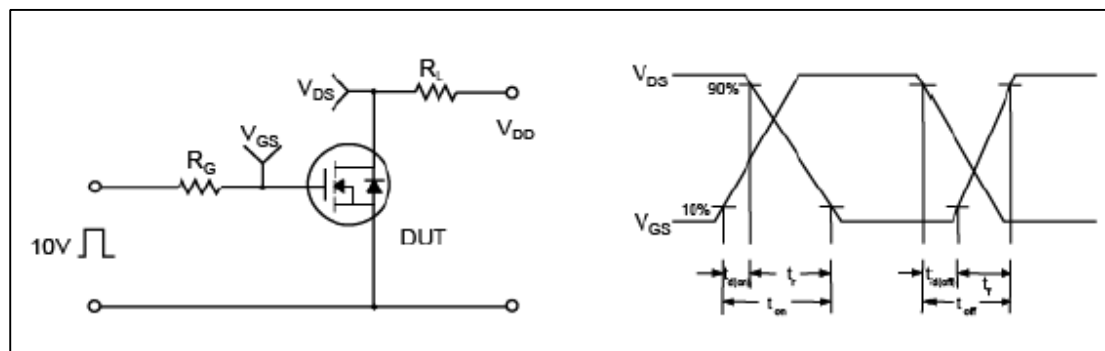

Fig.11 Resistive Switching Test Circuit & Waveform

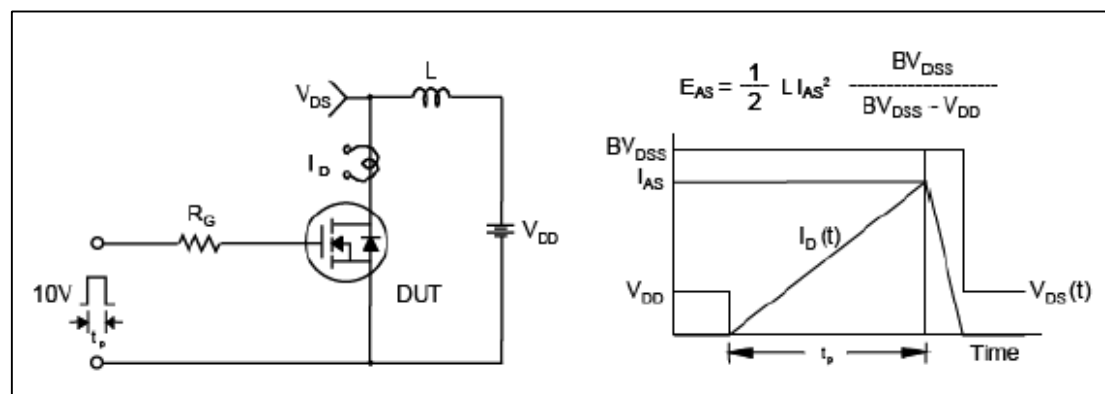

Fig.12 Uncamped Inductive Switching Test Circuit & Waveform

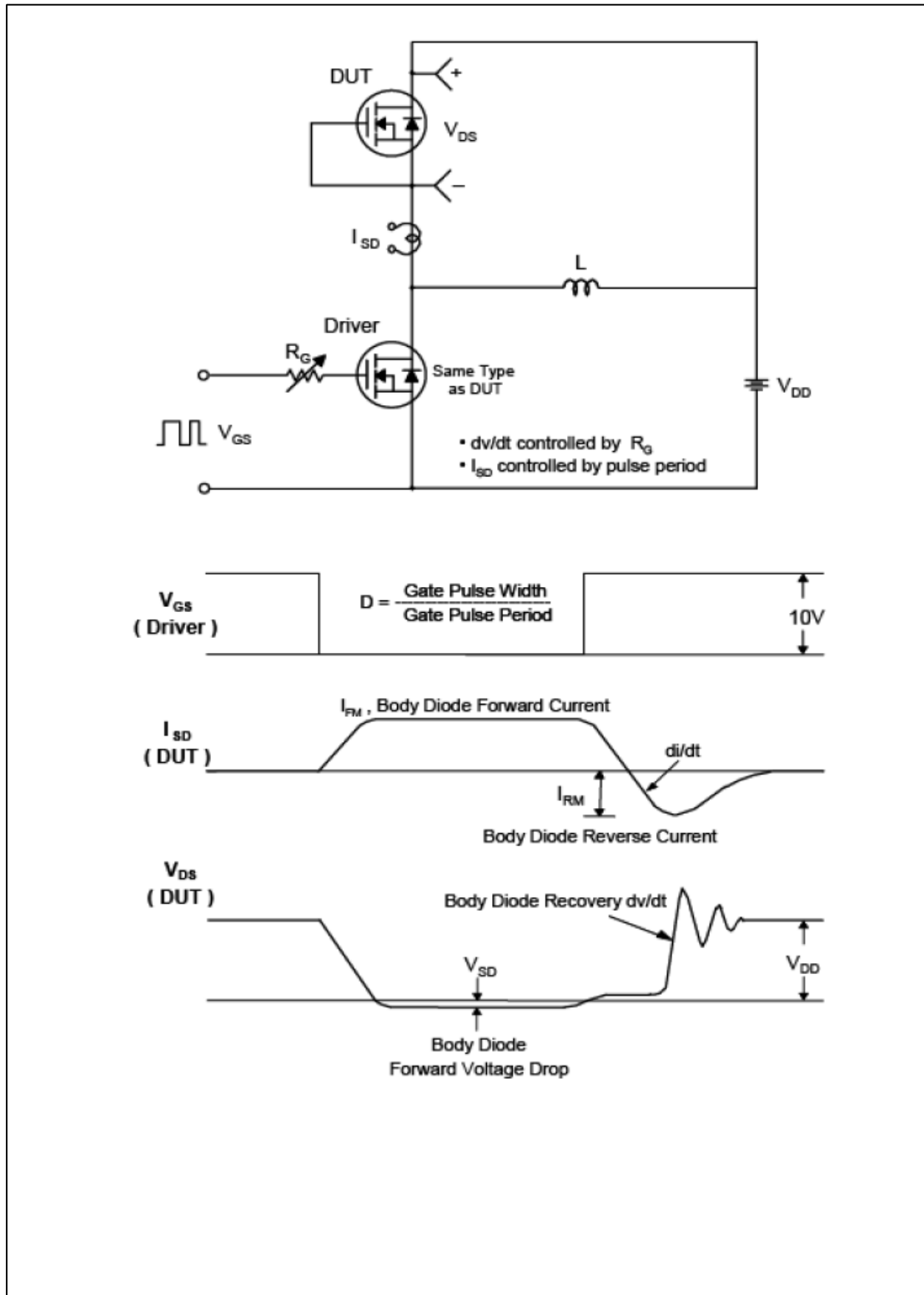

Fig.13 Peak Diode Recovery dv/dt Test Circuit & Waveform

TO-220 Package Dimension

