

## POWER TRANSISTOR E13001

### SWITCHING REGULATOR APPLICATION

- High speed switching
- Suitable for switching regulator and motor control
- Case : TO-92 molded plastic body

TO-92

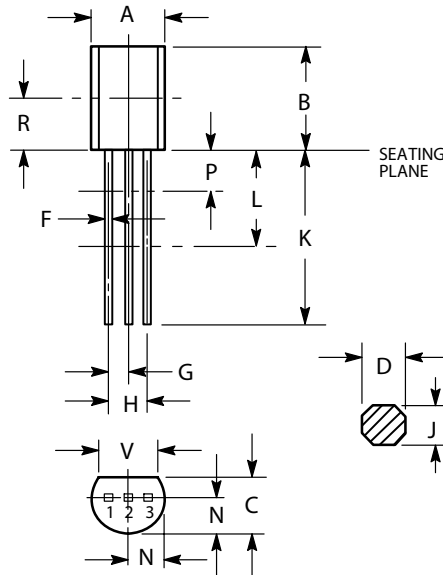

DIM	INCHES		MILLIMETERS	
	MIN	MAX	MIN	MAX
A	0.175	0.205	4.44	5.21
B	0.290	0.310	7.37	7.87
C	0.125	0.165	3.18	4.19
D	0.018	0.022	0.46	0.56
F	0.016	0.019	0.41	0.48
G	0.045	0.055	1.15	1.39
H	0.095	0.105	2.42	2.66
J	0.018	0.024	0.46	0.61
K	0.500	---	12.70	---
L	0.250	---	6.35	---
N	0.080	0.105	2.04	2.66
P	---	0.100	---	2.54
R	0.135	---	3.43	---
V	0.135	---	3.43	---

### NPN SILICON TRANSISTOR

### FEATURES $T_c=25^\circ\text{C}$ unless otherwise specified

Parameter	Symbol	Value	UNIT
Power dissipation	$P_{CM}$	0.75	W
Collector current	$I_{CM}$	0.2	A
Operating and storage junction temperature range	$T_J, T_{STG}$	-55 °C to +150 °C	°C

### ELECTRICAL CHARACTERISTICS $T_c=25^\circ\text{C}$ unless otherwise specified

Parameter	Symbol	Test conditions	MIN	MAX	UNIT
Collector-base breakdown voltage	$V_{(BR)CBO}$	$I_C=100\mu\text{A}, I_E=0$	600		V
Collector-emitter breakdown voltage	$V_{(BR)CEO}$	$I_C=1\text{mA}, I_B=0$	400		V
Emitter-base breakdown voltage	$V_{(BR)EBO}$	$I_E=100\mu\text{A}, I_C=0$	7		V
Collector cut-off current	$I_{CBO}$	$V_{CB}=600\text{V}, I_E=0$		100	$\mu\text{A}$
Collector cut-off current	$I_{CEO}$	$V_{CE}=400\text{V}, I_B=0$		200	$\mu\text{A}$
Emitter cut-off current	$I_{EBO}$	$V_{EB}=7\text{V}, I_C=0$		100	$\mu\text{A}$
DC current gain	$h_{FE(1)}$	$V_{CE}=20\text{V}, I_C=20\text{mA}$	10	70	
	$h_{FE(2)}$	$V_{CE}=10\text{V}, I_C=0.25\text{mA}$	5		
Collector-emitter saturation voltage	$V_{CEsat}$	$I_C=50\text{mA}, I_B=10\text{mA}$		0.5	V
Base-emitter saturation voltage	$V_{BEsat}$	$I_C=50\text{mA}, I_B=10\text{mA}$		1.2	V
Base-emitter voltage	$V_{BE}$	$I_E=100\text{mA}$		1.1	V
Transition frequency	$f_t$	$V_{CE}=20\text{V}, I_C=20\text{mA}$ $f=1\text{MHz}$	8		MHz
Fall time	$t_f$	$I_C=50\text{mA}, I_{B1}=-I_{B2}=5\text{mA}$		0.3	$\mu\text{S}$
Storage time	$t_s$	$V_{CC}=45\text{V}$		1.5	$\mu\text{S}$

## RATINGS AND CHARACTERISTIC CURVES E13001

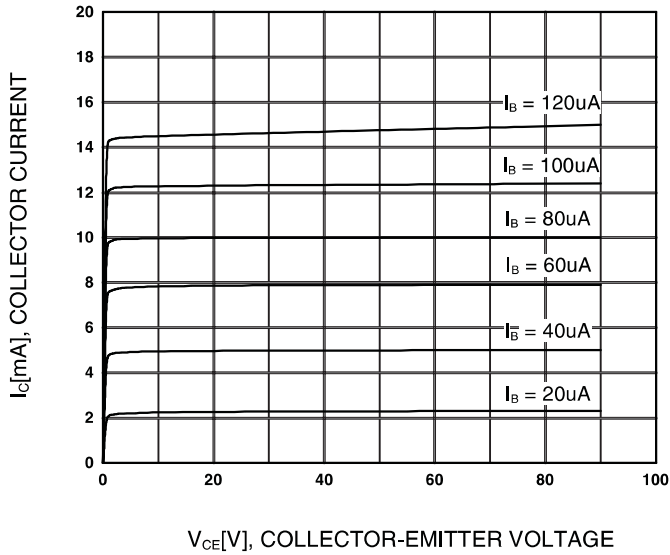

Figure 1. Static Characteristic

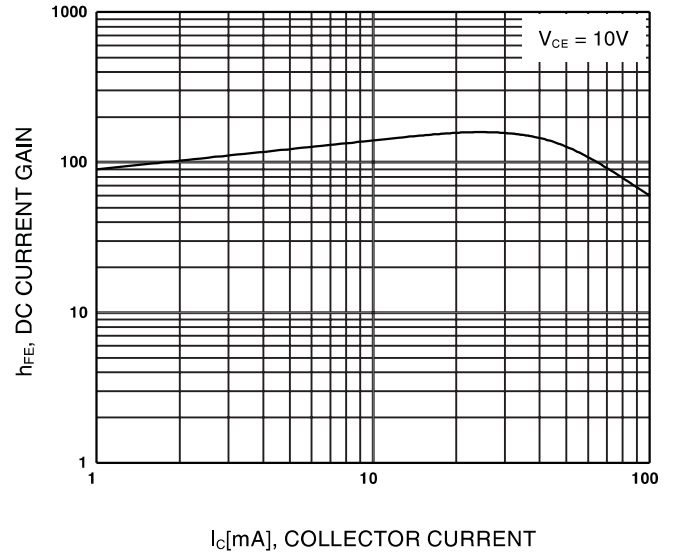

Figure 2. DC current Gain

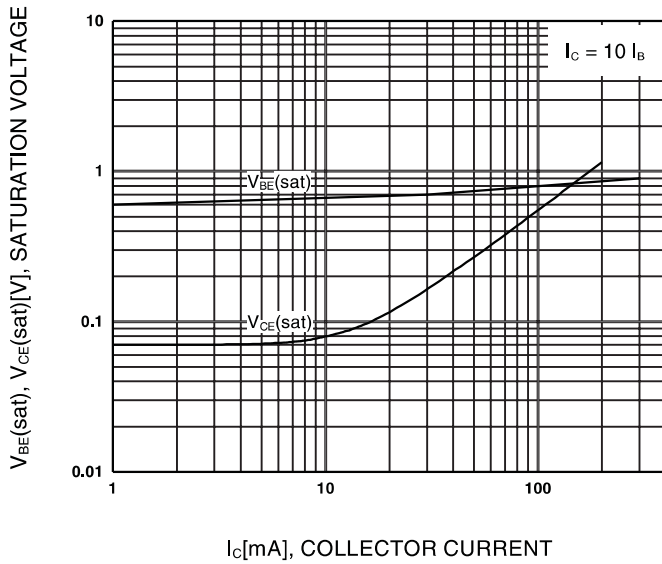

Figure 3. Base-Emitter Saturation Voltage  
Collector-Emitter Saturation Voltage

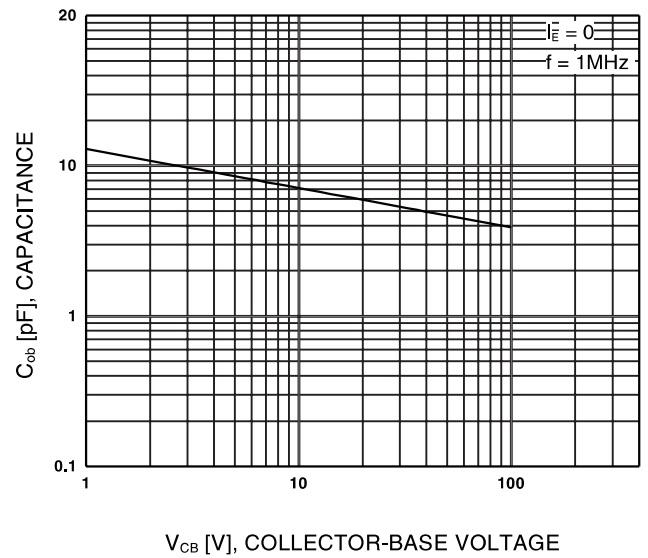

Figure 4. Collector Output Capacitance