

DATA SHEET

GQZ2.0~GQZ56

SURFACE MOUNT ZENER DIODES

VOLTAGE 2.0 to 56 Volts **POWER** 500 mWatts

QUADRO-MELF

Unit : inch (mm)

FEATURES

- Planar Die construction
- 500mW Power Dissipation
- Ideally Suited for Automated Assembly Processes

MECHANICAL DATA

- Case: Molded Glass QUADRO-MEIF
- Terminals: Solderable per MIL-STD-202E, Method 208
- Polarity: See Diagram Below
- Approx. Weight: 0.03 grams
- Mounting Position: Any
- Packing information

T/R - 2.5K per 7" plastic Reel

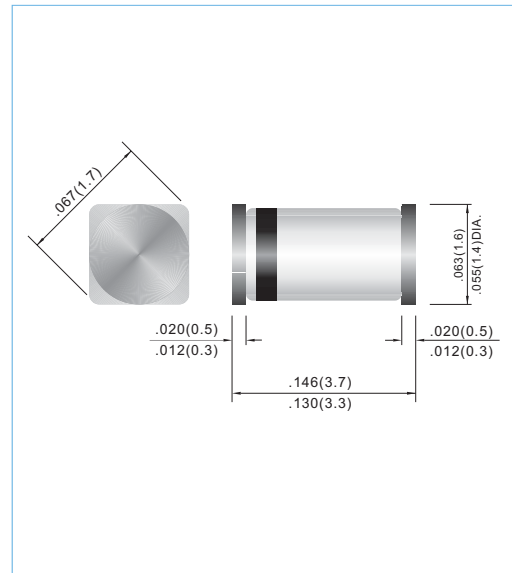

MAXIMUM RATINGS AND ELECTRICAL CHARACTERISTICS

Parameter	Symbol	Value	Units
Power Dissipation at Tamb = 25 °C	P _{TOT}	500	mW
Junction Temperature	T _J	175	°C
Storage Temperature Range	T _S	-65 to +175	°C

Valid provided that leads at a distance of 10mm from case are kept at ambient temperature.

Parameter	Symbol	Min.	Typ.	Max.	Units
Thermal Resistance Junction to Ambient Air	R _{thA}	--	--	0.3	K/mW
Forward Voltage at I _F = 100mA	V _F	--	--	1	V

Valid provided that leads at a distance of 10mm from case are kept at ambient temperature.

Part Number	CLASS	Vz @ IzT		IZ (mA)	VR (V)	IR(μA) MAX	Izt (mA)	ZzT(Ω) MAX	Izk (mA)	Zzk(Ω) MAX
		Min. V	Max. V							
GQZ 2.0	A	1.88	2.10	20	0.5	120	20	140	1	2000
	B	2.02	2.20							
GQZ 2.2	A	2.12	2.30	20	0.7	120	20	120	1	2000
	B	2.22	2.41							
GQZ 2.4	A	2.33	2.52	20	1.0	120	20	100	1	2000
	B	2.43	2.63							
GQZ 2.7	A	2.54	2.75	20	1.0	120	20	100	1	1000
	B	2.69	2.91							
GQZ 3.0	A	2.85	3.07	20	1.0	50	20	80	1	1000
	B	3.01	3.22							
GQZ 3.3	A	3.16	3.38	20	1.0	20	20	70	1	1000
	B	3.32	3.53							
GQZ 3.6	A	3.455	3.695	20	1.0	10	20	60	1	1000
	B	3.60	3.845							
GQZ 3.9	A	3.74	4.01	20	1.0	5	20	50	1	1000
	B	3.89	4.16							
GQZ 4.3	A	4.04	4.29	20	1.0	5	20	40	1	1000
	B	4.17	4.43							
	C	4.30	4.57							
GQZ 4.7	A	4.44	4.68	20	1.0	5	20	25	1	900
	B	4.55	4.80							
	C	4.68	4.93							
GQZ 5.1	A	4.81	5.07	20	1.5	5	20	20	1	800
	B	4.94	5.20							
	C	5.09	5.37							
GQZ 5.6	A	5.28	5.55	20	2.5	5	20	13	1	500
	B	5.45	5.73							
	C	5.61	5.91							
GQZ 6.2	A	5.78	6.09	20	3.0	5	20	10	1	300
	B	5.96	6.27							
	C	6.12	6.44							
GQZ 6.8	A	6.29	6.63	20	3.5	2	20	8	0.5	150
	B	6.49	6.83							
	C	6.66	7.01							
GQZ 7.5	A	6.85	7.22	20	4.0	0.5	20	8	0.5	120
	B	7.07	7.45							
	C	7.29	7.67							
GQZ 8.2	A	7.53	7.92	20	5.0	0.5	20	8	0.5	120
	B	7.78	8.19							
	C	8.03	8.45							
GQZ 9.1	A	8.29	8.73	20	6.0	0.5	20	8	0.5	120
	B	8.57	9.01							
	C	8.83	9.30							
GQZ 10	A	9.12	9.59	20	7.0	0.2	20	8	0.5	120
	B	9.41	9.90							
	C	9.70	10.20							
	D	9.94	10.44							
GQZ 11	A	10.18	10.71	10	8.0	0.2	10	10	0.5	120
	B	10.50	11.05							
	C	10.82	11.38							

Part Number	CLASS	Vz @ IZT		IZ (mA)	VR (V)	IR(uA) MAX	Izt (mA)	ZzT(Ω) MAX	Izk (mA)	Zzk(Ω) MAX
		Min. V	Max. V							
GQZ 12	A	11.13	11.71	10	9.0	0.2	10	12	0.5	110
	B	11.44	12.03							
	C	11.74	12.35							
GQZ 13	A	12.11	12.75	10	10	0.2	10	14	0.5	110
	B	12.55	13.21							
	C	12.99	13.66							
GQZ 15	A	13.44	14.13	10	11	0.2	10	16	0.5	110
	B	13.89	14.62							
	C	14.35	15.09							
GQZ 16	A	14.80	15.57	10	12	0.2	10	18	0.5	150
	B	15.25	16.04							
	C	15.69	16.51							
GQZ 18	A	16.22	17.06	10	13	0.2	10	23	0.5	150
	B	16.82	17.70							
	C	17.42	18.33							
GQZ 20	A	18.02	18.96	10	15	0.2	10	28	0.5	200
	B	18.63	19.59							
	C	19.23	20.22							
	D	19.72	20.72							
GQZ 22	A	20.15	21.20	5	17	0.2	5	30	0.5	200
	B	20.64	21.71							
	C	21.08	22.17							
	D	21.52	22.63							
GQZ 24	A	22.05	23.18	5	19	0.2	5	35	0.5	200
	B	22.61	23.77							
	C	23.12	24.31							
	D	23.63	24.85							
GQZ 27	A	24.26	25.52	5	21	0.2	5	45	0.5	250
	B	24.97	26.26							
	C	25.63	26.95							
	D	26.29	27.64							
GQZ 30	A	26.99	28.39	5	23	0.2	5	55	0.5	250
	B	27.70	29.13							
	C	28.36	29.82							
	D	29.02	30.51							
GQZ 33	A	29.68	31.22	5	25	0.2	5	65	0.5	250
	B	30.32	31.88							
	C	30.90	32.50							
	D	31.49	33.11							
GQZ 36	A	32.14	33.79	5	27	0.2	5	75	0.5	250
	B	32.79	34.49							
	C	33.40	35.13							
	D	34.01	35.77							
GQZ 39	A	34.68	36.47	5	30	0.2	5	85	0.5	250
	B	35.36	37.19							
	C	36.00	37.85							
	D	36.63	38.52							
GQZ 43		40.00	45.00	5	33	0.2	5	90	--	
GQZ 47		44.00	49.00	5	36	0.2	5	90	--	
GQZ 51		48.00	54.00	5	39	0.2	5	110	--	
GQZ 56		53.00	60.00	5	43	0.2	5	110	--	

RATING AND CHARACTERISTIC CURVES

