



## MICRF112

### QwikRadio® UHF ASK/FSK Transmitter

## General Description

The MICRF112 is a high performance, easy to use, single chip ASK / FSK Transmitter IC for remote wireless applications in the 300 to 450MHz frequency band. This transmitter IC is a true "data-in, antenna-out" monolithic device.

MICRF112 is high performance in three areas: power delivery, operating voltage, and operating temperature. In terms of power, the MICRF112 is capable of delivering +10 dBm into a 50Ω load. This power level enables a small form factor transmitter (lossy antenna) such as a key fob transmitter to operate near the maximum limit of transmission regulations. In terms of operating voltage, the MICRF112 operates from 3.6V to 1.8V. Many transmitter ICs in the same frequency band stop operating below 2.0V. The MICRF112 will work with most batteries to the end of their useful limits. In terms of operating temperature, the MICRF112 operates from -40°C to +125°C. This wide operating temperature range makes MICRF112 an ideal candidate for the demanding applications such as a tire pressure monitoring system.

The MICRF112 is easy to use. One only needs a reference frequency (RF carrier frequency divided by 32 times) generated from a crystal with a few additional external parts to create a complete versatile transmitter.

The MICRF112 operates with ASK/OOK (Amplitude Shift Keying/On-Off Keyed) UHF receiver types from wide-band super-regenerative radios to narrow-band, high performance super-heterodyne receivers. The MICRF112's maximum ASK data rate is 50kbps (Manchester Encoding). It operates with FSK receivers as well. The chip is designed to support narrow band FSK (Frequency Shift Modulation) by switching an external capacitor in parallel with the reference crystal. The MICRF112's maximum FSK data rate is 10kbps.

## Features

- Complete UHF transmitter
- Frequency range 300MHz to 450MHz
- Data rates up to 50kbps ASK, 10kbps FSK
- Output Power to 10dBm
- Low external part count
- Low standby current <1μA
- Low voltage operation (down to 1.8V)
- Operate with crystals or ceramic resonators

## Applications

- Remote Keyless Entry Systems (RKE)
- Remote Control (STB, HVAC and Appliances)
- Garage Door Opener Transmitters
- Remote Sensor Data Links
- Infrared Transmitter Replacement
- Tire Pressure Monitor System (TPMS)

## Ordering Information

Part Number	Temp. Range	Package
MICRF112YMM10	-40°C to +125°C	10-Pin MSOP

QwikRadio is a registered trademark of Micrel, Inc.

Micrel Inc. • 2180 Fortune Drive • San Jose, CA 95131 • USA • tel +1 (408) 944-0800 • fax + 1 (408) 474-1000 • <http://www.micrel.com>

March 2007

M9999-030107  
(408) 944-0800

### Typical Application

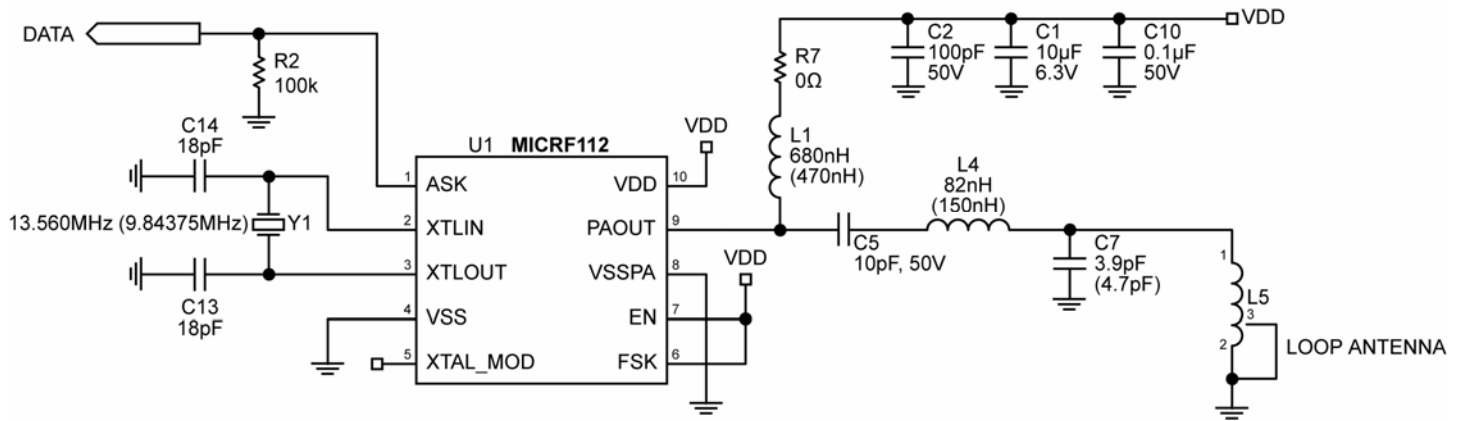
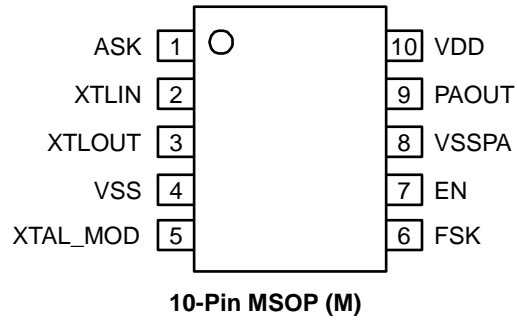

Figure 1. MICRF112 ASK Key Fob Design

Note: Values in parenthesis are for 315MHz

## Pin Configuration



## Pin Description

Pin Number MSOP-10	Pin Name	Pin Function
1	ASK	ASK DATA Input
2	XLIN	Reference oscillator input connection.
3	XTLOUT	Reference oscillator output connection.
4	VSS	Ground
5	XTAL_MOD	Reference oscillation modulation port for FSK operation.
6	FSK	FSK Data Input
7	EN	Chip enable, active high
8	VSSPA	PA Ground
9	PA_OUT	PA output
10	VDD	Positive Power Supply

**Absolute Maximum Ratings (Note 1)**

Supply Voltage VDD .....	+5.0V
Voltage on PAOUT .....	+7.2V
Voltage on I/O Pins.....	VSS-0.3 to VDD+0.3
Storage Temperature Range.....	-65°C to + 150°C
Lead Temperature (soldering, 10 seconds) .....	+ 300°C
ESD Rating .....	Note 3

**Operating Ratings (Note 2)**

Supply Voltage VDD .....	1.8V to 3.6V
Ambient Operating Temperature (TA).....	-40°C to +125°C
Programmable Transmitter Frequency Range:	
.....	300MHz to 450MHz

**Electrical Characteristics (Note 4)**

Specifications apply for VDD = 3.0V, TA = 25°C, Freq<sub>REFOSC</sub> = 13.560MHz, EN = VDD. Bold values indicate -40°C to 125°C unless otherwise noted. 1kbps data rate 50% duty cycle. RL 50ohm load (matched)

Parameter	Condition	Min	Typ	Max	Units
<b>Power Supply</b>					
Standby supply current, Iq	EN = Vss		.05	1μA	μA
Mark Supply Current I <sub>ON</sub>	@ 315MHz, P <sub>OUT</sub> = +10dBm		12.3		mA
	@ 433.92MHz, P <sub>OUT</sub> = +10dBm		12.5		mA
SPACE supply current, I <sub>OFF</sub>	@ 315MHz		2		mA
	@ 433.92 MHz		2		mA
<b>RF Output Section and Modulation Limits:</b>					
Output power level, P <sub>OUT</sub> FSK or ASK "mark"	@315MHz, <sup>Note 4</sup>		10		dBm
	@433.92MHz, <sup>Note 4</sup>		10		dBm
Harmonics output for 315 MHz	@ 630MHz, <sup>Note 4</sup> 2nd harm.		-39		dBc
	@945MHz, <sup>Note 4</sup> 3rd harm.		-53		dBc
Harmonics output for 433.92 MHz	@ 867.84MHz, <sup>Note 4</sup> 2nd harm.		-55		dBc
	@1301.76MHz, <sup>Note 4</sup> 3rd harm.		-55		dBc
Extinction ratio for ASK			70		dBc
<b>FSK Modulation</b>					
Frequency Deviation	load capacitor = 10pF, crystal type = HC49/U		22		kHz
Data Rate				10	kbps
<b>ASK Modulation</b>					
Data Rate				50	kbps
Occupied Bandwidth	@315MHz, Note 6		<700		kHz
	@433.92MHz, Note 6		<1000		kHz
<b>VCO Section</b>					
315 MHz Single Side Band Phase Noise	@ 100kHz from Carrier		-76		dBc/Hz
	@ 1000kHz from Carrier		-79		dBc/Hz
433.92 MHz Single Side Band Phase Noise	@ 100kHz from Carrier		-72		dBc/Hz
	@ 1000kHz from Carrier		-81		dBc/Hz
<b>Reference Oscillator Section</b>					
XTLIN, XTLOUT, XTLMOD	Pin capacitance		2		pF
External Capacitance	See Schematic C17 & C18		18		pF
Oscillator Startup Time <sup>Note 5</sup>	Crystal: HC49S		300		μs
<b>Digital / Control Section</b>					
Output Blanking	STDBY transition from LOW to HIGH		500		μs

**Electrical Characteristics (cont.)**

Parameter	Condition	Min	Typ	Max	Units
Digital Input (EN, ASK and FSK)	High ( $V_{IH}$ )	$0.8 \times V_{DD}$			V
	Low ( $V_{IL}$ )			$0.2 \times V_{DD}$	V
Digital Input Leakage Current (EN, ASK and FSK Pins)	High ( $V_{IH}$ )		0.05		$\mu A$
	Low ( $V_{IL}$ )		0.05		$\mu A$
Under Voltage Lock Out (UVLO)			1.6		V

Note 1. Exceeding the absolute maximum rating may damage the device.

Note 2. The device is not guaranteed to function outside its operating rating.

Note 3. Devices are ESD sensitive. Handling precautions recommended. Human body model, 1.5k in series with 100pF.

Note 4. Measured using Test Circuit in Figure 2.

Note 5. Dependent on crystal

Note 6. RBW = 100kHz, OBW measured at -20dBc.

**Test Circuit**

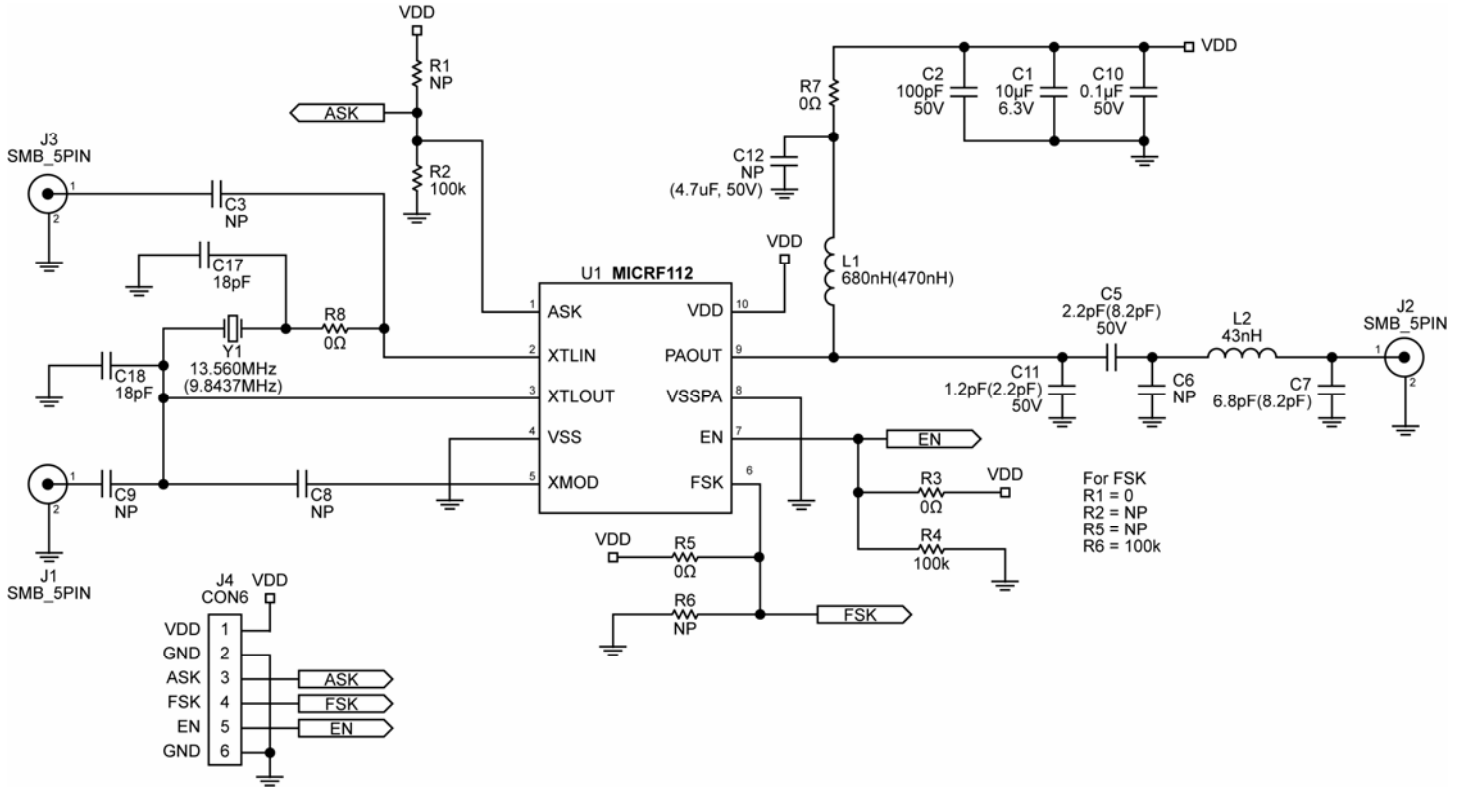
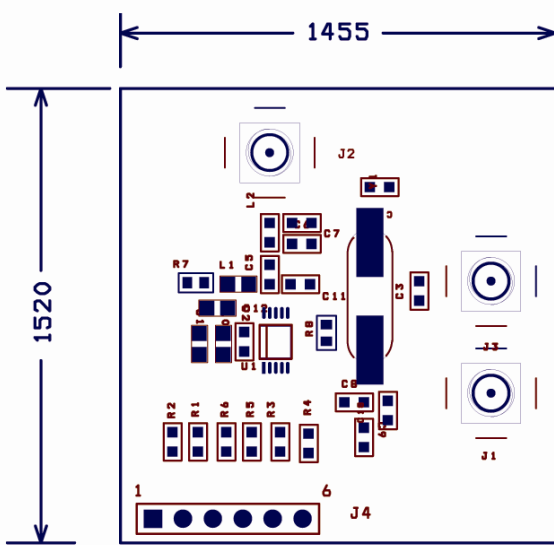

**Figure 2. MICRF112 Test Circuit with 50Ω Output**

Note 1. Values without parenthesis are for 433.92 MHz and values in parenthesis are for 315MHz

Note 2. C9 = 100pF for external REF-OSC

Note 3. For FSK R1 = 0Ω, R2 = NP, R6 = 100k, and R5 = NP



**Assembly Drawing**  
**MICRF112 50 Ohm Test Board**

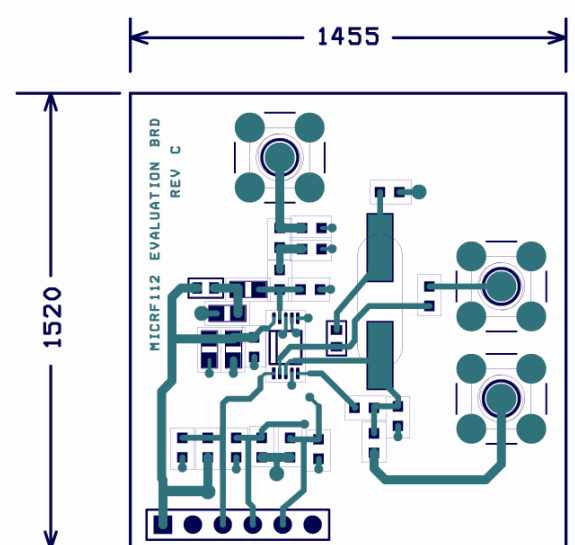

**Top Layer**  
**MICRF112 50 Ohm Test Board**

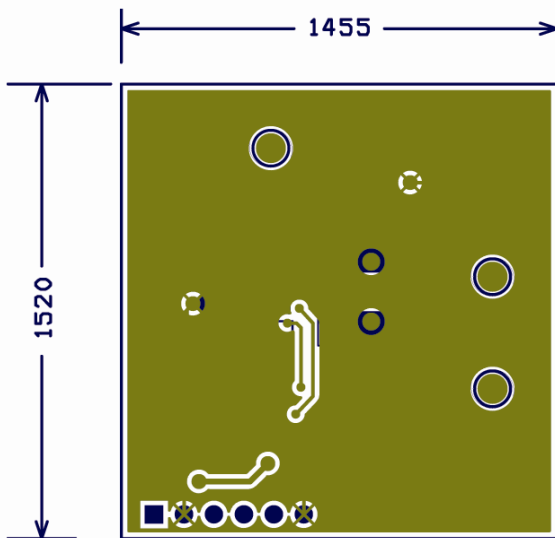

**Bottom Layer**  
**MICRF112 50 Ohm Test Board**

## Typical Characteristics Using MICRF112, 50Ω test Board

**315MHz OBW, ASK = 1kHz**

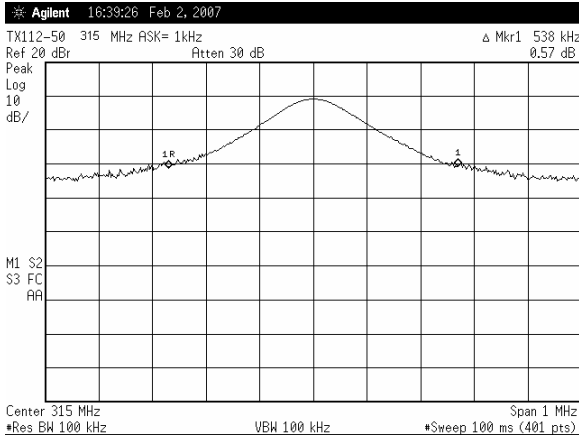

**315MHz OBW, ASK = 50kHz**

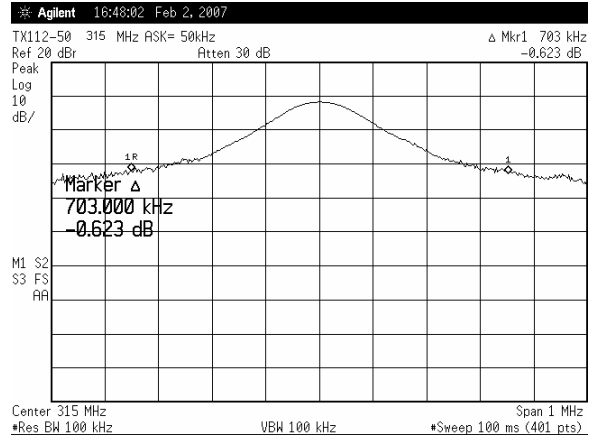

**CW Max Power @ 3V, 315MHz,  
ASK = 1kHz, Note 1**

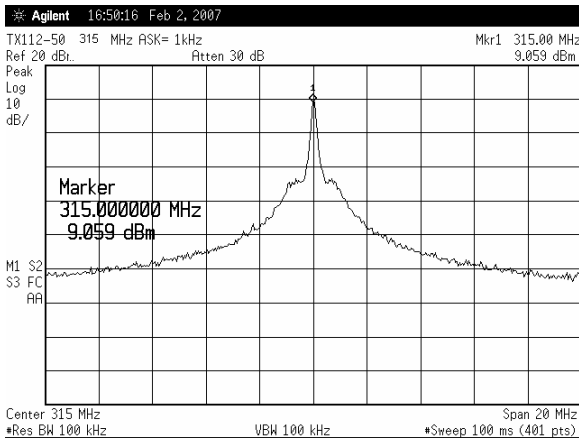

**RF Spectrum 2<sup>nd</sup> Harmonic;  
Fundamental at 315 MHz**

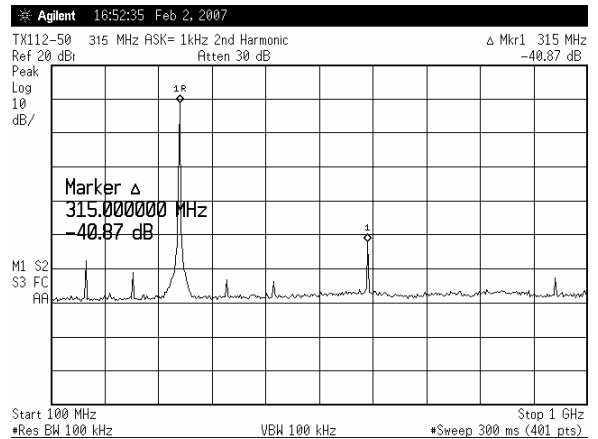

**RF Spectrum 3<sup>rd</sup> Harmonic;  
Fundamental at 315 MHz**

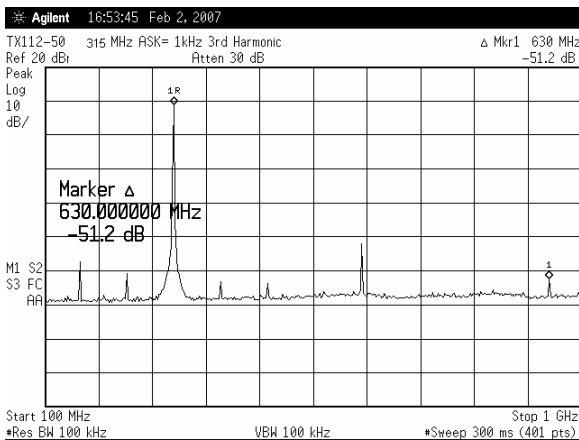

**315MHz, Power Level at Space,  
VDD = 3.0V, ASK = 1kHz**

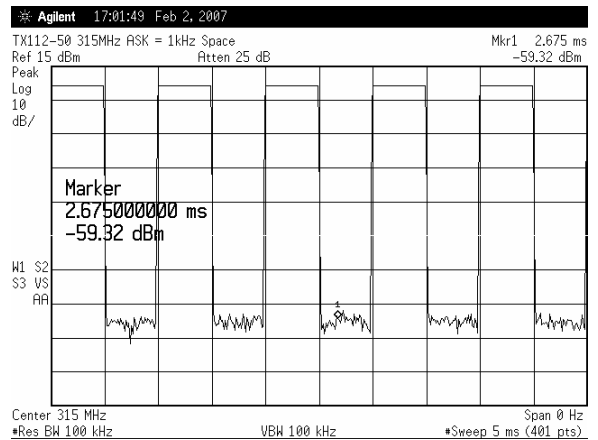

Note 1. 1.2dB cable loss.



**315MHz, Zero Span , ASK = 1kHz**

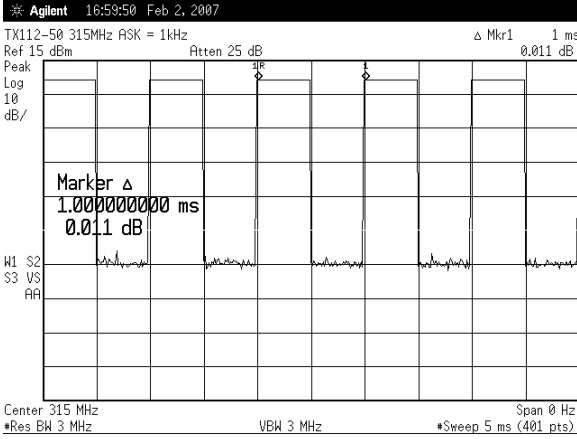

**315MHz, Zero Span, ASK = 50kHz**

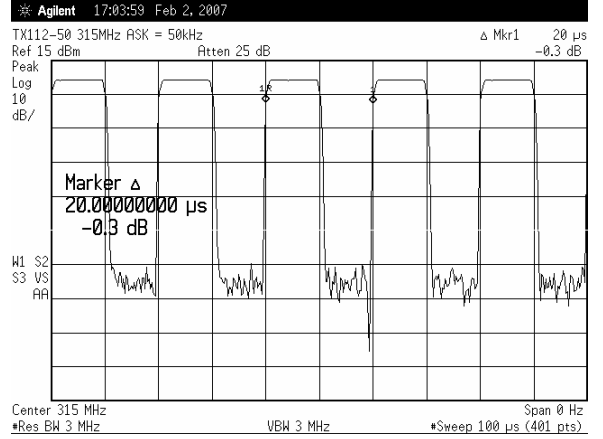

**315MHz, Phase Noise, ASK = 1kHz, 100kHz Offset, -75.59dBc/Hz**

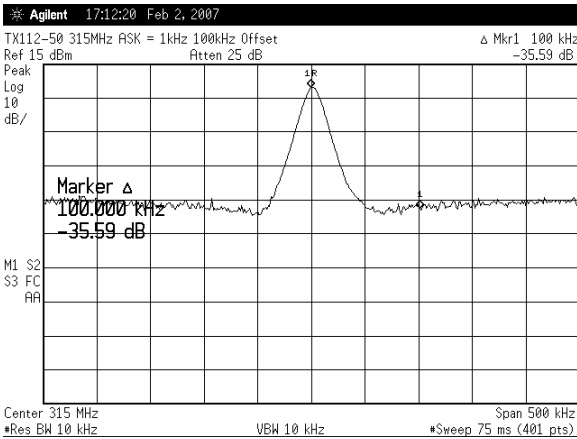

**315MHz, Phase Noise, ASK = 1kHz, 1MHz Offset, -78.99dBc/Hz**

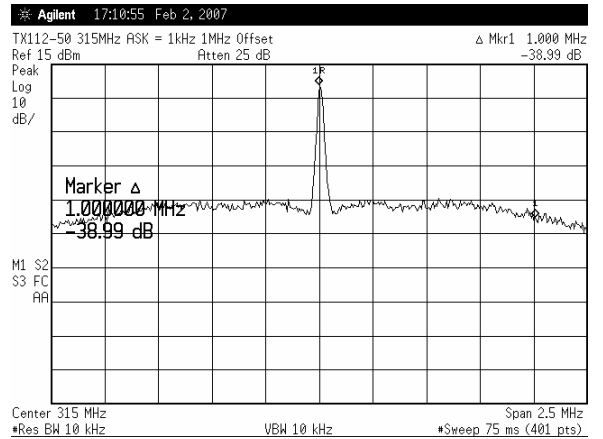

**315MHz, Phase Noise, ASK = CW, 100kHz Offset, -74.39dBc/Hz**

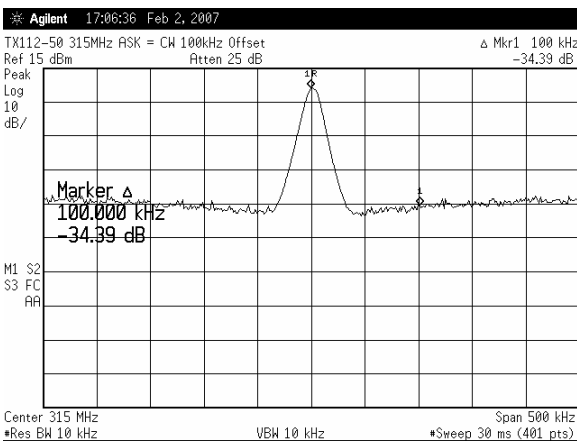

**315MHz, Phase Noise, ASK = CW, 1MHz Offset, -77.28dBc/Hz**

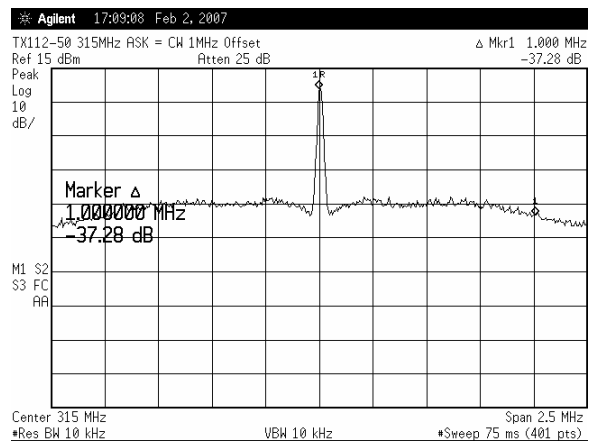

**433.92MHz OBW, ASK = 1kHz**

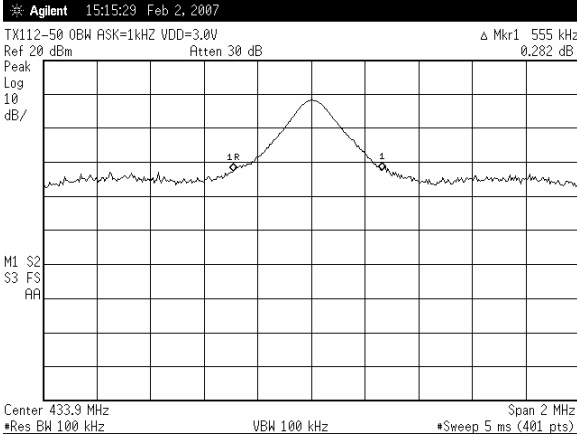

**433.92MHz OBW, ASK = 50kHz**

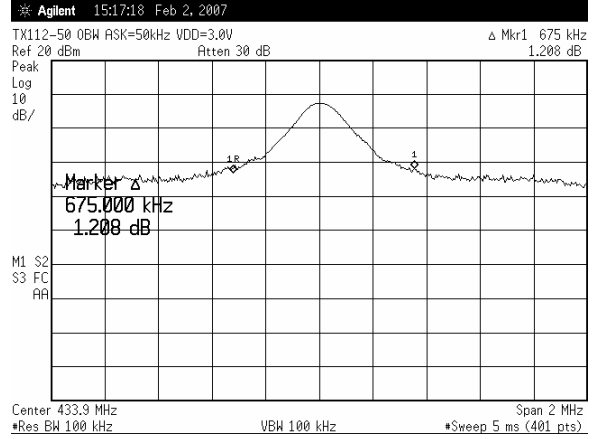

**433.92MHz, CW Max Power @ 3V, ASK = 1kHz, Note 1**

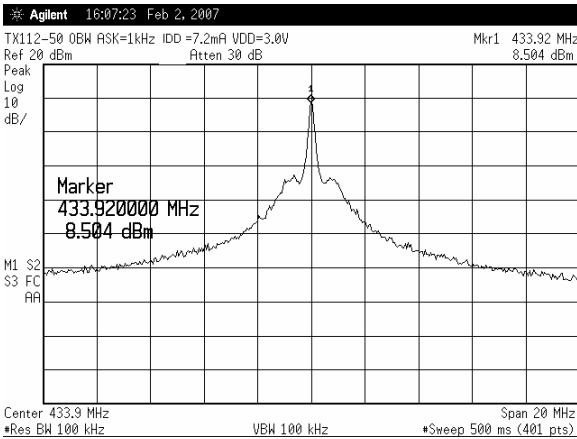

**RF Spectrum 2<sup>nd</sup> Harmonic; Fundamental at 433.92 MHz**

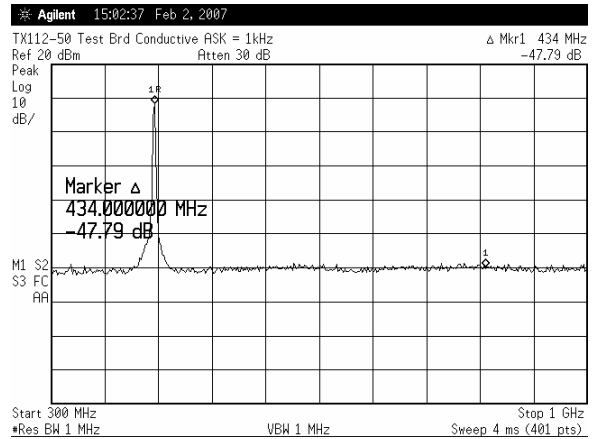

**RF Spectrum 3<sup>rd</sup> Harmonic; Fundamental at 433.92 MHz**

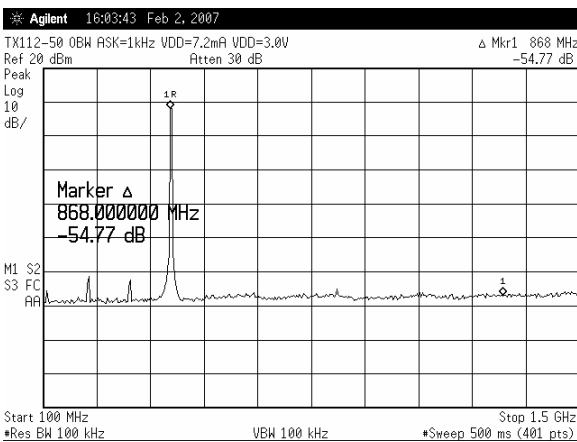

**433.92MHz Power Level at Space, VDD = 3.0V, ASK = 1kHz**

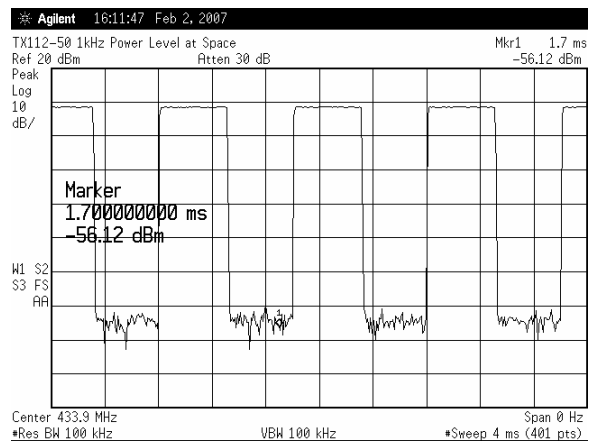

Note 1. 1.3dB cable loss.

**433.92MHz Zero Span, 1kHz**

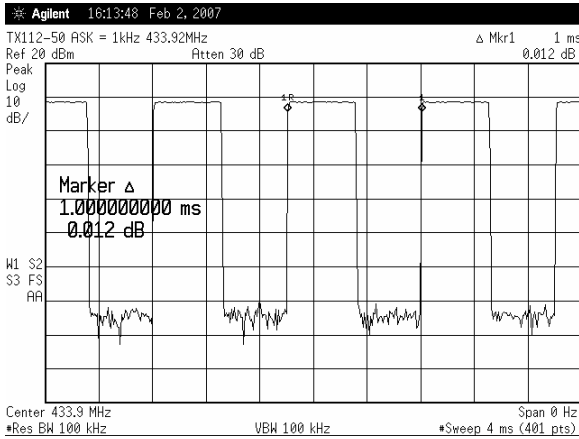

**433.92ASK Zero Span at 50kHz**

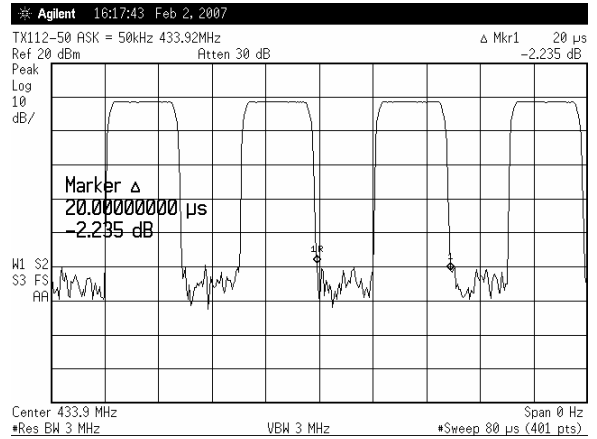

**433.92MHz Phase Noise, ASK = CW, 100kHz Offset, -81.04dBc/Hz**

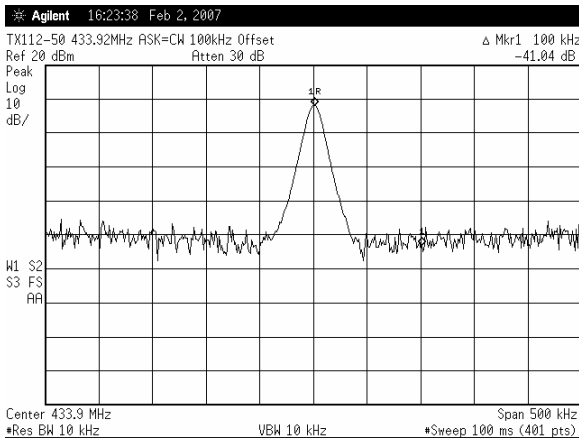

**433.92MHz Phase Noise, ASK = CW, 1MHz Offset, -78.76dBc/Hz**

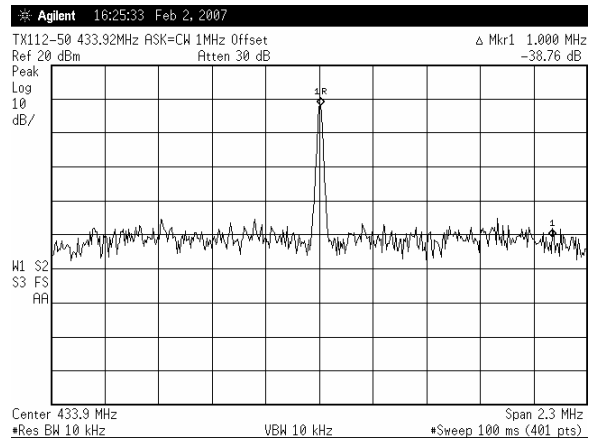

**433.92MHz Phase Noise, ASK = 1kHz, 100kHz Offset, -71.73dBc/Hz**

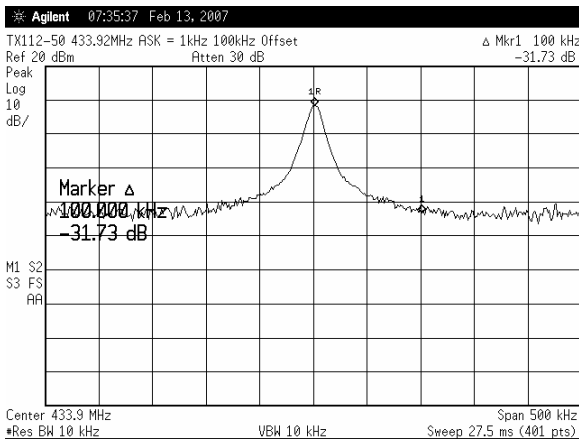

**433.92MHz Phase Noise, ASK = 1kHz, 1MHz Offset, -81.04dBc/Hz**

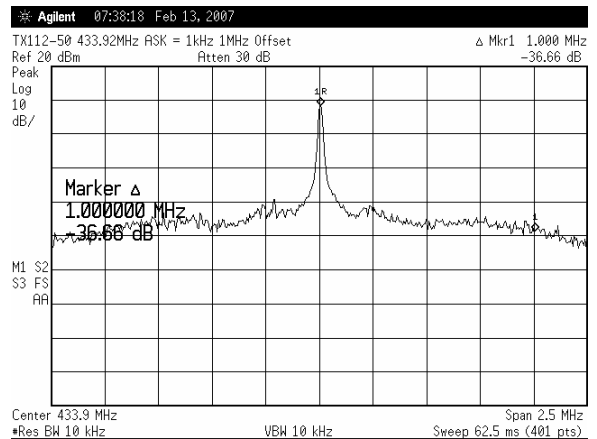

## Functional Diagram

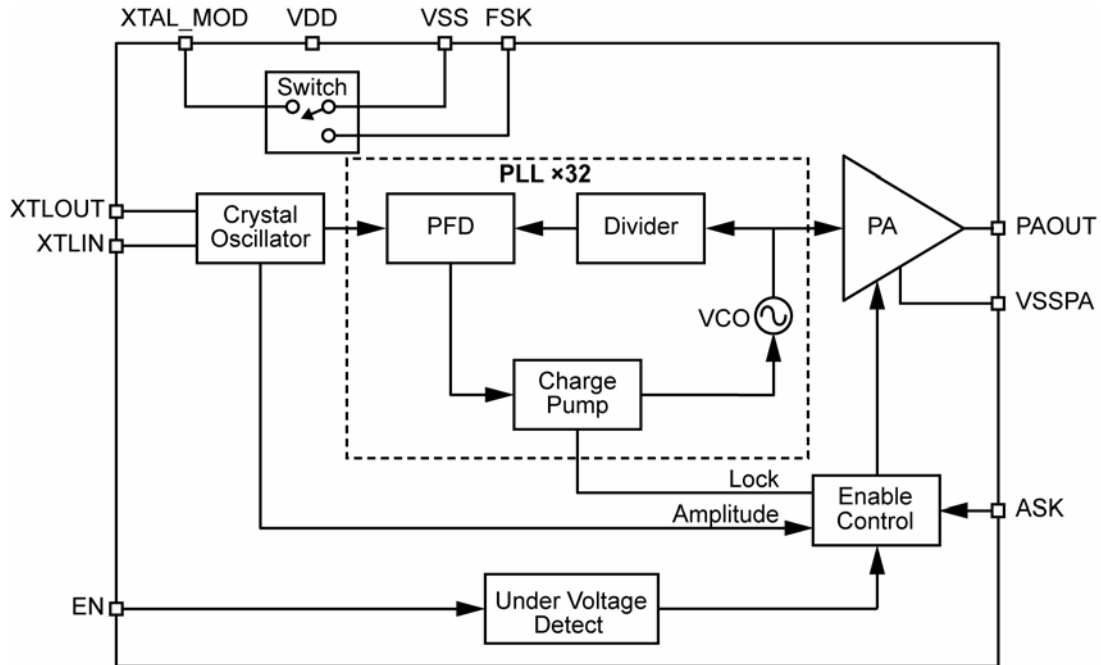

Figure 3. Functional Block Diagram MICRF112 10 Pin ASK / FSK Version

## Functional Description

Figure 3 shows a functional block diagram of the MICRF112 transmitter. The MICRF112 can be best described as a phase locked transmitter. The system can be partitioned into six functional blocks; crystal oscillator, PLLx32, power amplifier, enable control, under voltage detect and open drain switch for FSK operation.

### Crystal Oscillator

The reference oscillator is crystal-based Pierce configuration. It is designed to accept crystals with frequency from 9.375MHz to 14.0625MHz.

### Crystal Oscillator Parameters for ASK Operation

Figure 4 shows a reference oscillator circuit configuration for ASK operation. The reference oscillator is capable of driving crystals with ESR range from 20Ω to 300Ω.

When the ESR of crystal is at 20Ω, the crystal parameter limits are:

- ESR 20Ω
- C<sub>PAR</sub> 2 to 10pF
- C<sub>MO</sub> 10 to 40fF

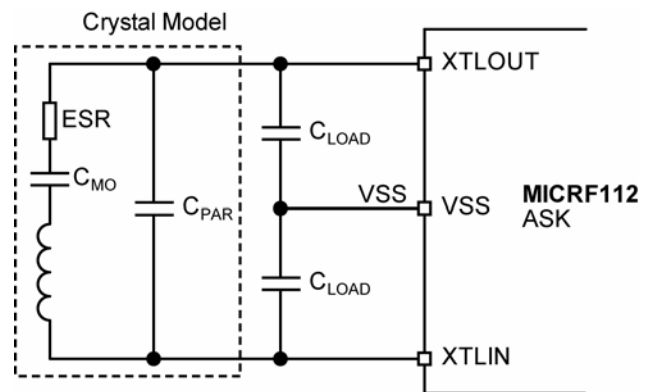

Figure 4. Reference Oscillator ASK Operation

When the ESR of crystal is at 300Ω, the crystal parameter limits are:

- |                   |            |
|-------------------|------------|
| ESR               | 300Ω       |
| C <sub>PAR</sub>  | 2 to 5pF   |
| C <sub>MO</sub>   | 10 to 40fF |
| C <sub>LOAD</sub> | 10 to 30pF |

### Crystal Oscillator for FSK Operation

Figure 5 shows reference oscillator circuit configuration for FSK operation. To operate the MICRF112 in FSK mode, one additional capacitor is needed between XTALOUT pin and XTALMOD pin. Crystal parameters for FSK operation are the same as ASK operation except:

- When the ESR of crystal is at  $20\Omega$ ,  $C_{FSK} + C_{LOAD}$  not to exceed 70pF.
- When the ESR of crystal is at  $300\Omega$ ,  $C_{FSK} + C_{LOAD}$  not to exceed 30pF

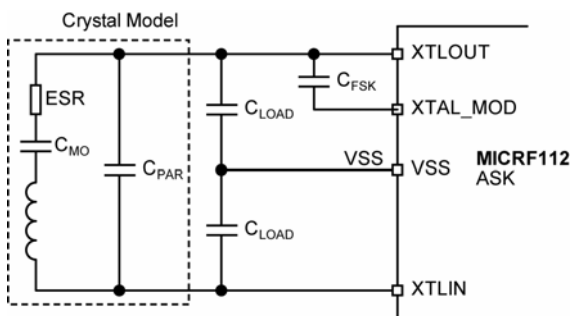

Figure 5. Reference Oscillator FSK Operation

### PLL x32

The function of PLLx32 is to provide a stable carrier frequency for transmission. It is a "divided by 32" phase locked oscillator.

### Power Amplifier

The power amplifier serves two purposes: 1) to buffer the VCO from external elements and 2) to amplify the phase locked signal. The power amplifier can produce +10dBm at 3V (typical).

### Enable Control

Enable control gates the ASK data. It only allows transmission when Lock, Amplitude and Under Voltage Detect conditions are valid.

### Under Voltage Detect

"Under voltage detect" block senses operating voltage. If the operating voltage falls below 1.6V, "under voltage detect" block will send a signal to "enable control" block to disable the PA.

### Open Drain Switch

Open drain switch is used for FSK operation. FSK data is fed into the FSK pin. The FSK pin is connected to the gate of the open drain switch. The open collector is connected to the XTALMOD pin. In Figure 4, a capacitor is shown connected from XTALMOD pin to XTALOUT. When FSK pin goes high, the capacitor between XTALMOD and XTALOUT pulls the frequency of REFOSC low.

## Application Information

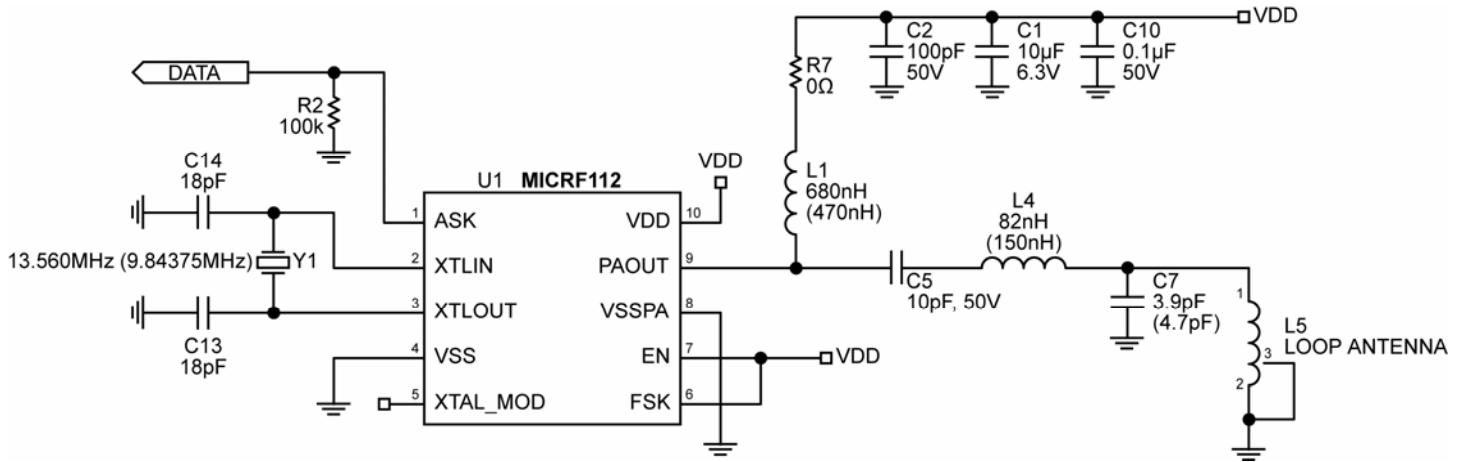

Figure 6. ASK 433.92MHz and 315MHz

Note: Values in parenthesis are for 315MHz

The MICRF112 is well suited to drive a 50 ohms source, monopole or a loop antenna. Figure 6 is an example of a loop antenna configuration. Figure 6 also shows both 315MHz and 433.92MHz ASK configurations for a loop antenna. Besides using a different crystal, Table 1 lists modified values needed for the listed frequencies.

Frequency (MHz)	L1 (nH)	C5 (pF)	L4 (nH)	C7 (pF)	Y1 (MHz)
315.0	470	10	150	6.8	9.84375
433.92	680	10	82	4.7	13.5600

Table 1

The reference design shown in Figure 6 has an antenna optimized for using the matching network as described in Table 1.

### Power Control Using External Resistor

R7 is used to adjust the RF output levels which may be needed to meet compliance. As an example, the following tables list typical values of conducted RF output levels and corresponding R7 resistor values for the 50Ω test board shown in Figure 2. R7 of the TX112 Demo board using the loop antenna can be adjusted for the appropriate radiated field allowed by FCC or ETSI compliance. Contact Micrel for suggested values to meet FCC and ETSI compliances.

R7, Ω	Output Power, dBm	IDD, mA
0	10	6.7
75	8.5	6.3
100	8.0	6.2
500	1.6	4.13
1000	-3.8	4.87

Output Power Versus External Resistor at 315MHz

R7, Ω	Output Power, dBm	IDD, mA
0	8.68	7.5
75	8.34	7.33
100	8.02	7.3
500	4.34	6.3
1000	0.42	5.5

Output Power Versus External Resistor at 433.92 MHz

**Output Matching Network**

Part of the function of the output network is to attenuate the second and third harmonics. When matching to a transmit frequency, care must be taken not only to optimize for maximum output power but to attenuate unwanted harmonics.

**Layout Issues**

PCB Layout is of primary concern to achieve optimum performance and consistent manufacturing results. Care must be used on orientation of components to ensure they do not couple or decouple the RF signal. PCB trace length should be short to minimize parasitic inductance, (1 inch ~ 20nH). For example, depending on inductance values, a 0.5 inch trace can change the inductance by as

much as 10%. To reduce parasitic inductance, the use of wide traces and a ground plane under signal traces is recommended. Vias with low value inductance should be used for components requiring a connection-to-ground.

**Antenna Layout**

Directivity is affected by antenna trace layout. No ground plane should be under the antenna trace. For consistent performance, components should not be placed inside the loop of the antenna. Gerbers for Figure 7, with a suggested layout, can be obtained on the Micrel web site at: <http://www.micrel.com>.

### PCB Board

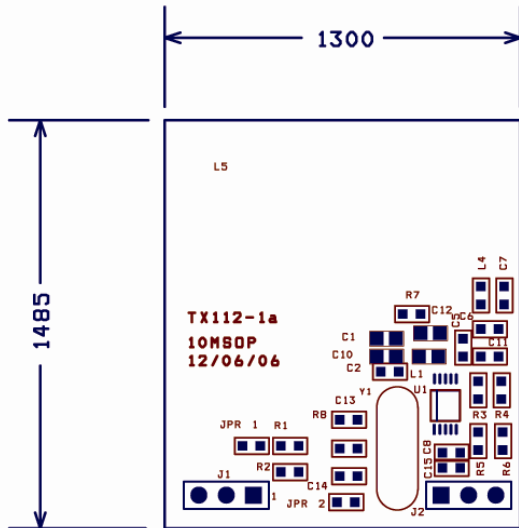

**Assembly Drawing**  
**MICRF112 Demo Board**

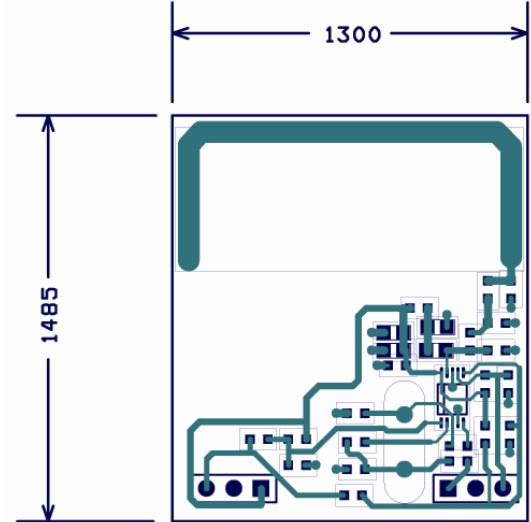

**Top Layer**  
**MICRF112 Demo Board**

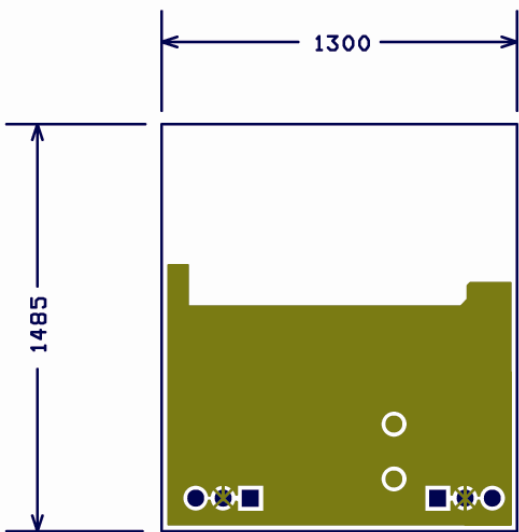

**Bottom Layer**  
**MICRF112 Demo Board**

**Figure 7. Demo Board PCB**



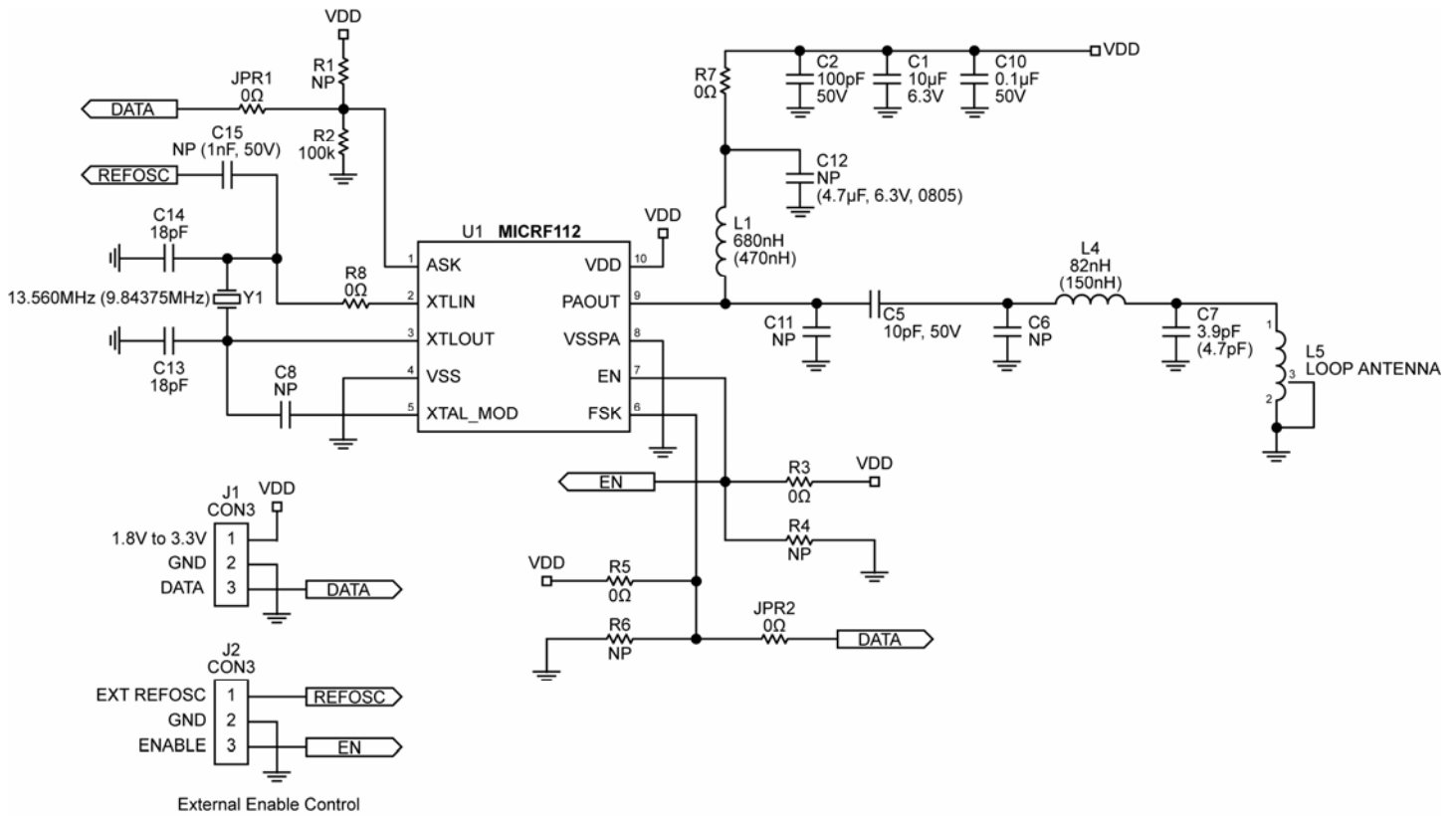

Figure 8. TX112-1 Demo Board Schematic

Note: Configuration is for ASK operation. Values in parenthesis are for 315MHz

## Functional Description of TX112-1 Evaluation Board.

Figure 7 shows the TX112-1 Demo Board PCB. Figure 8 is a detailed schematic of the TX112-1. Note that

components labeled as NP are to obtain different configurations including FSK Mode of operation. Table 2 describes each header pin connector used in the demo board.

Pin	Function Name	Functional Description
J1-1	VDD	1.8V to 3.6V
J1-2	Ground	VSS
J1-3	ASK INPUT	Modulating Data Input, ASK or FSK
J2-1	REF-OSC	External Reference Input
J2-2	GROUND	VSS
J2-3	ENABLE	Enable Input, Active High

## TX112-1-433.92 ASK Bill of Materials

Item	Quantity	Ref	Part	PCB Footprint	Mfg P/N	Manufacturer
1	1	C1	10 $\mu$ F	0805	GRM21BR60J106KE01L	muRata
2	1	C2	100pF	0603	GRM1885C1H101JA01D	muRata
3	1	C5	10pF	0603	GRM1885C1H100JA01D	muRata
4	3	R1,R4,R6	(np)			
5	5	C6,C8,C11,C12,C15	(np)			
6	1	C7	4.7pF	0603	GRM1885C1H4R7JA01D	muRata
7	1	C10	0.1 $\mu$ F	0603	GRM188F51H104ZA01D	muRata
8	2	C13,C14	18pF	0603	GRM1885C1H180JA01D	muRata
9	2	J1,J2	CON3		TSHR-114-S-02-A-GT	
10	1	L1	680nH	0805	0805CS-680XJB	Coilcraft
11	1	L4	82nH	0603	0603CS-082NXJB	Coilcraft
12	1	L5	ANTENNA		ANTENNA LOOP, Part of PCB	
13	1	R2	100k $\Omega$	0603	CRCW0603100KFKEA	Vishay
14	6	R3,R5,R7 R8,JPR1,JPR2	0 $\Omega$	0603	CRC06030000Z0EA	Vishay
13	1	U1	MICRF112YMM10		MICRF112YM	Micrel
14	1	Y1	13.560MHZ XTAL		SA-13.5600-F-10-C-3-3	HIB

Table 2

**Tx112-1-315MHz ASK Bill of Materials**

Item	Quantity	Ref	Part	PCB Footprint	Mfg P/N	Manufacturer
1	1	C1	10µF	0805	GRM21BR60J106KE01L	muRata
2	1	C2	100pF	0603	GRM1885C1H101JA01D	muRata
3	1	C5	10pF	0603	GRM1885C1H1000JA01D	muRata
4	3	R1,R4,R6	(np)			
5	5	C6,C8,C11,C12,C15	(np)			
6	1	C7	4.7pF	0603	GRM1885C1H6R8JA01D	muRata
7	1	C10	0.1µF	0603	GRM188F51H104ZA01D	muRata
8	2	C13,C14	18pF	0603	GRM1885C1H180JA01D	muRata
9	2	J1,J2	CON3		TSHR-114-S-02-A-GT	
10	1	L1	470nH	0805	0805CS-470XJB	Coilcraft
11	1	L4	150nH	0603	0603CS-R15XJB	Coilcraft
12	1	L5	ANTENNA		ANTENNA LOOP, Part of PCB	
13	1	R2	100kΩ	0603	CRCW0603100KFKEA	Vishay
14	6	R3,R5,R7 R8,JPR1,JPR2	0Ω	0603	CRC06030000Z0EA	Vishay
13	1	U1	MICRF112YMM10		MICRF112YM	Micrel
14	1	Y1	9.84375MHZ XTAL		SA-9.84375-F-10-C-3-3	HIB

**Table 3**

**FSK Operation**

Table 2 and 3 describe the ASK operation for 433.92MHz and 315MHz.

Table 4 lists the component values that change between ASK or FSK operation. Please note that use of a high FSK data rate may excite parasitic resonant modes with some crystal types. Recommended crystals from Table 2 and 3 are good for both ASK and FSK.

Mode	R1	R2	R5	R6	JPR1	JPR2	C8
ASK	NP	100kΩ	0Ω	NP	0Ω	NP	NP
FSK	0Ω	NP	NP	100kΩ	NP	0Ω	(1)3.3pF (2)10pF

Notes:

1. C8 = 3.3pF for 1kHz using HC49/U or HC49US type crystals.
2. C8= 10pF for 10kHz using HC49/U, (high profile) only.

**Table 4: ASK and FSK Settings**

	R3	R4
Constant ON	0Ω	NP
External Standby Control	NP	100kΩ

**Table 5: Enable Control (Shutdown)**

**Package Information**

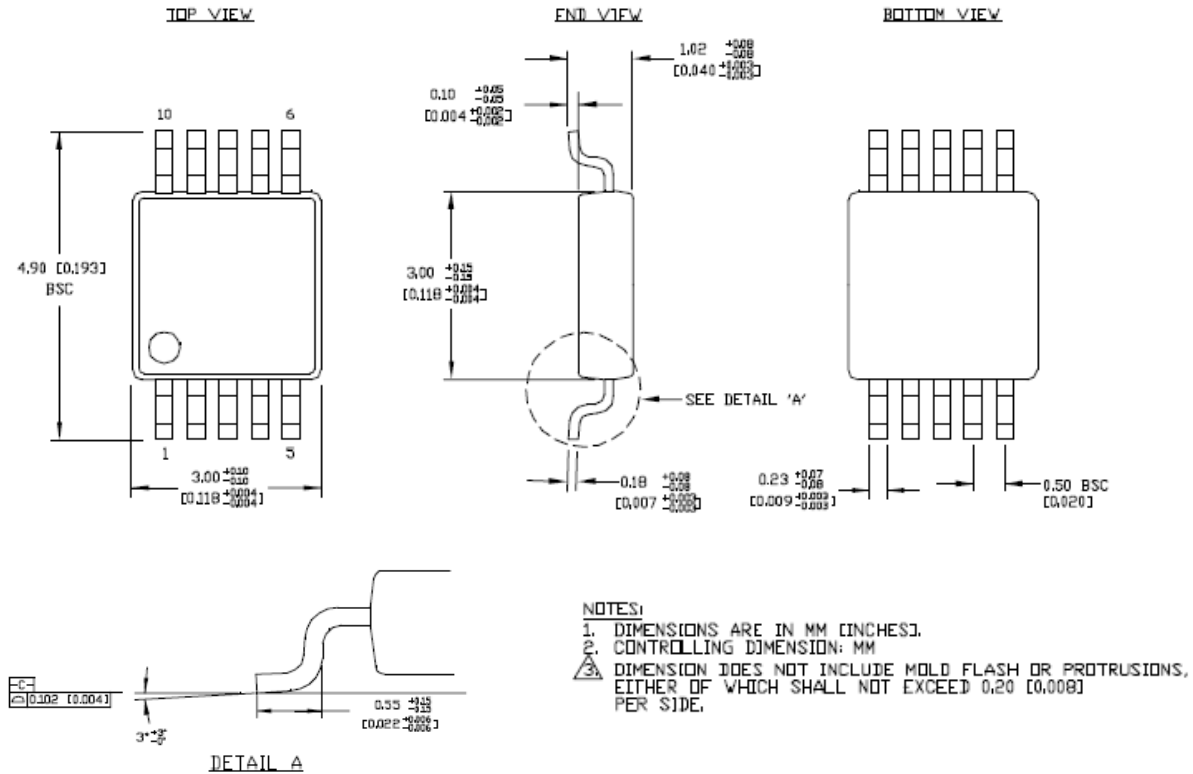

**10-Pin MSOP Package Type (YMM10)**

**MICREL, INC. 2180 FORTUNE DRIVE SAN JOSE, CA 95131 USA**  
 TEL +1 (408) 944-0800 FAX +1 (408) 474-1000 WEB <http://www.micrel.com>

The information furnished by Micrel in this data sheet is believed to be accurate and reliable. However, no responsibility is assumed by Micrel for its use. Micrel reserves the right to change circuitry and specifications at any time without notification to the customer.

Micrel Products are not designed or authorized for use as components in life support appliances, devices or systems where malfunction of a product can reasonably be expected to result in personal injury. Life support devices or systems are devices or systems that (a) are intended for surgical implant into the body or (b) support or sustain life, and whose failure to perform can be reasonably expected to result in a significant injury to the user. A Purchaser's use or sale of Micrel Products for use in life support appliances, devices or systems is at Purchaser's own risk and Purchaser agrees to fully indemnify Micrel for any damages resulting from such use or sale.

© 2007 Micrel, Incorporated.