



Solid Tantalum Chip Capacitors

MIDGET® Military, MIL-PRF-55365/4 Qualified



FEATURES

- Weibull Failure Rates B, C; Exponential M, P, R, S.
- Tape and Reel available per EIA 481-1 and-2.
- Termination finishes available; Gold Plate, 50µ inch minimum (standard), Solder Plated Hot Solder Dipped.

PERFORMANCE CHARACTERISTICS

Operating Temperature: - 55°C to + 85°C. (To + 125°C with voltage derating.)

Capacitance Range: 0.10µF-100µF

Capacitance Tolerance: ± 10%, ± 20% standard. ± 5% available as special.

Voltage Rating: 4WVDC to 50WVDC.

ORDERING INFORMATION						
CWR06 TYPE	D VOLTAGE	B TERMINATION FINISH	155 CAPACITANCE	K CAPACITANCE TOLERANCE	B FAILURE RATE %/1000 HOURS	OPTIONAL SURGE CURRENT OPTIONS
	C = 4 V D = 6 V F = 10V H = 15 V J = 20 V K = 25 V M = 35 V N = 50 V	B = Gold. Standard. H = Solder Plate. C = Solder Dipped	This is expressed in picofarads. The first two digits are the significant figures. The third is the number of zeros to follow.	K = ± 10% M = ± 20% J = ± 5%	A = Commercial M = 1.0 P = 0.1 R = 0.01 S = 0.001 B = 0.1 C = 0.01	A = 10 Cycles at +25°C B = 10 Cycles at -55°C and +85°C. C = 10 Cycles at -55°C and +85°C (Before Weibull Grading).

DIMENSIONS in inches [millimeters]

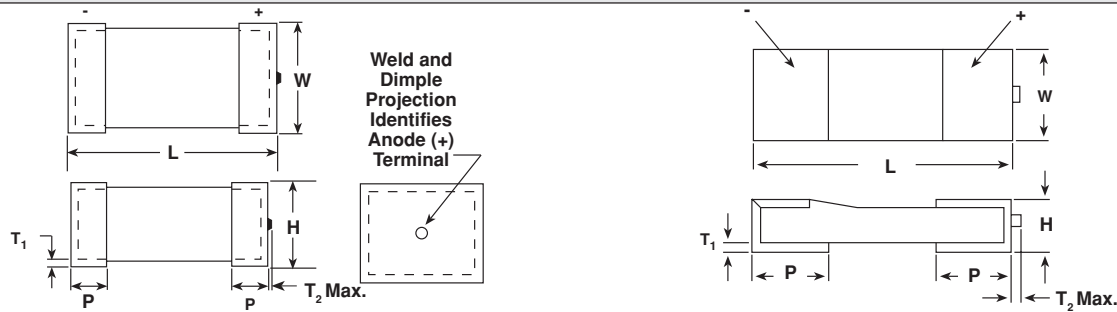

CASE CODE	L	W	H	P	T ₁	T ₂ (Max.)
A	0.100 ± 0.015 [2.54 ± 0.38]	0.050 ± 0.015 [1.27 ± 0.38]	0.050 ± 0.015 [1.27 ± 0.38]	0.030 ± 0.005 [0.76 ± 0.13]	0.005 [0.13]	0.015 [0.38]
B	0.150 ± 0.015 [3.81 ± 0.38]	0.050 ± 0.015 [1.27 ± 0.38]	0.050 ± 0.015 [1.27 ± 0.38]	0.030 ± 0.005 [0.76 ± 0.13]	0.005 [0.13]	0.015 [0.38]
C	0.200 ± 0.015 [5.08 ± 0.38]	0.050 ± 0.015 [1.27 ± 0.38]	0.050 ± 0.015 [1.27 ± 0.38]	0.030 ± 0.005 [0.76 ± 0.13]	0.005 [0.13]	0.015 [0.38]
D	0.150 ± 0.015 [3.81 ± 0.38]	0.100 ± 0.015 [2.54 ± 0.38]	0.050 ± 0.015 [1.27 ± 0.38]	0.030 ± 0.005 [0.76 ± 0.13]	0.005 [0.13]	0.015 [0.38]
E	0.200 ± 0.015 [5.08 ± 0.38]	0.100 ± 0.015 [2.54 ± 0.38]	0.050 ± 0.015 [1.27 ± 0.38]	0.030 ± 0.005 [0.76 ± 0.13]	0.005 [0.13]	0.015 [0.38]
F	0.220 ± 0.015 [5.59 ± 0.38]	0.135 ± 0.015 [3.43 ± 0.38]	0.070 ± 0.015 [1.78 ± 0.38]	0.030 ± 0.005 [0.76 ± 0.13]	0.005 [0.13]	0.015 [0.38]
G	0.265 ± 0.015 [6.73 ± 0.38]	0.110 ± 0.015 [2.79 ± 0.38]	0.110 ± 0.015 [2.79 ± 0.38]	0.050 ± 0.005 [1.27 ± 0.13]	0.005 [0.13]	0.015 [0.38]
H	0.285 ± 0.015 [7.24 ± 0.38]	0.150 ± 0.015 [3.81 ± 0.38]	0.110 ± 0.015 [2.79 ± 0.38]	0.050 ± 0.005 [1.27 ± 0.13]	0.005 [0.13]	0.015 [0.38]

Note: When solder coated terminations are required, add .015" [0.38mm] to termination dimension tolerances.



RATINGS AND CASE CODES								
μF	4 V	6 V	10 V	15 V	20 V	25 V	35 V	50 V
0.10								A
0.15								A
0.22							A	B
0.33						A		B
0.47					A		B	C
0.68				A	B	B	C	D
1.0			A		B	C	D	E
1.5		A		B	C	D	E	F
2.2	A		B	C	D	E		F
3.3		B	C	D	E		F	G
4.7	B	C	D	E		F	G	H
6.8	C	D	E		F	G	H	
10	D	E		F		G		
15	E		F		G	H		
22		F		G	H			
33	F		G	H				
47		G	H					
68	G	H						
100	H							

STANDARD RATINGS									
CAPACITANCE (μF)	CASE CODE	PART NUMBER*	Max. DCL (μA) @			Max. DF (%) @			Max. ESR @ + 25°C 100kHz (Ohms)
			+ 25°C	+ 85°C	+ 125°C	+ 25°C	+ 85°C + 125°C	- 55°C	
4 WVDC @ + 85°C, SURGE = 5 V . . . 2.7 WVDC @ + 125°C, SURGE = 3.4 V									
2.2	A	CWR06C@225#*	1.0	10	12	6	8	8	8.0
4.7	B	CWR06C@475#*	1.0	10	12	6	8	8	8.0
6.8	C	CWR06C@685#*	1.0	10	12	6	8	8	5.5
10	D	CWR06C@106#*	1.0	10	12	8	8	10	4.0
15	E	CWR06C@156#*	1.0	10	12	8	10	12	3.5
33	F	CWR06C@336#*	2.0	20	24	8	10	12	2.2
68	G	CWR06C@686#*	3.0	30	36	10	12	12	1.1
100	H	CWR06C@107#*	4.0	40	48	10	12	12	0.9
6 WVDC @ + 85°C, SURGE = 8 V . . . 4 WVDC @ + 125°C, SURGE = 5 V									
1.5	A	CWR06D@155#*	1.0	10	12	6	8	8	8.0
3.3	B	CWR06D@335#*	1.0	10	12	6	8	8	8.0
4.7	C	CWR06D@475#*	1.0	10	12	6	8	8	5.5
6.8	D	CWR06D@685#*	1.0	10	12	6	8	8	4.5
10	E	CWR06D@106#*	1.0	10	12	8	10	12	3.5
22	F	CWR06D@226#*	2.0	20	24	8	10	12	2.2
47	G	CWR06D@476#*	3.0	30	36	10	12	12	1.1
68	H	CWR06D@686#*	4.0	40	48	10	12	12	0.9
10 WVDC @ + 85°C, SURGE = 13 V . . . 7 WVDC @ + 125°C, SURGE = 9 V									
1.0	A	CWR06F@105#*	1.0	10	12	6	8	8	12.0
2.2	B	CWR06F@225#*	1.0	10	12	6	8	8	8.0
3.3	C	CWR06F@335#*	1.0	10	12	6	8	8	5.5
4.7	D	CWR06F@475#*	1.0	10	12	6	8	8	4.5
6.8	E	CWR06F@685#*	1.0	10	12	6	8	8	3.5
15	F	CWR06F@156#*	2.0	20	24	8	8	10	2.5
33	G	CWR06F@336#*	3.0	30	36	10	12	12	1.1
47	H	CWR06F@476#*	5.0	50	60	10	12	12	0.9

@ = Termination Finish: B = Gold (standard), H = solder Plated, C = Hot solder dipped
 # = Cap.Tolerance: J = 5%, K = 10%, M = 20%.
 * = Failure Rate B, C Weibull
 M, P, R, S Exponential



STANDARD RATINGS									
CAPACITANCE (μ F)	CASE CODE	PART NUMBER*	Max. DCL (μ A) @			Max. DF (%) @			Max. ESR @ + 25°C 100kHz (Ohms)
			+ 25°C	+ 85°C	+ 125°C	+ 25°C	+ 85°C + 125°C	- 55°C	
15 WVDC @ + 85°C, SURGE = 20 V . . . 10 WVDC @ + 125°C, SURGE = 12 V									
0.68	A	CWR06H@684#*	1.0	10	12	6	8	8	12.0
1.5	B	CWR06H@155#*	1.0	10	12	6	8	8	8.0
2.2	C	CWR06H@225#*	1.0	10	12	6	8	8	5.5
3.3	D	CWR06H@335#*	1.0	10	12	6	8	8	5.0
4.7	E	CWR06H@475#*	1.0	10	12	6	8	8	4.0
10	F	CWR06H@106#*	2.0	20	24	6	8	8	2.5
22	G	CWR06H@226#*	4.0	40	48	8	8	10	1.1
33	H	CWR06H@336#*	5.0	50	60	8	8	10	0.9
20 WVDC @ + 85°C, SURGE = 26 V . . . 13 WVDC @ + 125°C, SURGE = 16 V									
0.47	A	CWR06J@474#*	1.0	10	12	6	8	8	16.0
0.68	B	CWR06J@684#*	1.0	10	12	6	8	8	14.0
1.0	B	CWR06J@105#*	1.0	10	12	6	8	8	12.0
1.5	C	CWR06J@155#*	1.0	10	12	6	8	8	6.0
2.2	D	CWR06J@225#*	1.0	10	12	6	8	8	5.0
3.3	E	CWR06J@335#*	1.0	10	12	6	8	8	4.0
6.8	F	CWR06J@685#*	2.0	20	24	6	8	8	2.4
15	G	CWR06J@156#*	3.0	30	36	6	8	8	1.1
22	H	CWR06J@226#*	4.0	40	48	6	8	8	0.9
25 WVDC @ + 85°C, SURGE = 32 V . . . 17 WVDC @ + 125°C, SURGE = 20 V									
0.33	A	CWR06K@334#*	1.0	10	12	6	8	8	15.0
0.68	B	CWR06K@684#*	1.0	10	12	6	8	8	10.0
1.0	C	CWR06K@105#*	1.0	10	12	6	8	8	6.5
1.5	D	CWR06K@155#*	1.0	10	12	6	8	8	6.5
2.2	E	CWR06K@225#*	1.0	10	12	6	8	8	3.5
4.7	F	CWR06K@475#*	2.0	20	24	6	8	8	2.5
6.8	G	CWR06K@685#*	2.0	20	24	6	8	8	1.2
10	G	CWR06K@106#*	3.0	30	36	6	8	8	1.4
15	H	CWR06K@156#*	4.0	40	48	6	8	8	1.0
35 WVDC @ + 85°C, SURGE = 46 V . . . 23 WVDC @ + 125°C, SURGE = 28 V									
0.22	A	CWR06M@224#*	1.0	10	12	6	8	8	24.0
0.47	B	CWR06M@474#*	1.0	10	12	6	8	8	17.0
0.68	C	CWR06M@684#*	1.0	10	12	6	8	8	10.0
1.0	D	CWR06M@105#*	1.0	10	12	6	8	8	6.5
1.5	E	CWR06M@155#*	1.0	10	12	6	8	8	4.5
3.3	F	CWR06M@335#*	1.0	10	12	6	8	8	2.5
4.7	G	CWR06M@475#*	2.0	20	24	6	8	8	1.5
6.8	H	CWR06M@685#*	3.0	30	36	6	8	8	1.3
50 WVDC @ + 85°C, SURGE = 65 V . . . 33 WVDC @ + 125°C, SURGE = 38 V									
0.10	A	CWR06N@104#*	1.0	10	12	6	8	8	75.0
0.15	A	CWR06N@154#*	1.0	10	12	6	8	8	25.0
0.22	B	CWR06N@224#*	1.0	10	12	6	8	8	17.0
0.33	B	CWR06N@334#*	1.0	10	12	6	8	8	12.0
0.47	C	CWR06N@474#*	1.0	10	12	6	8	8	8.0
0.68	D	CWR06N@684#*	1.0	10	12	6	8	8	7.0
1.0	E	CWR06N@105#*	1.0	10	12	6	8	8	6.0
1.5	F	CWR06N@155#*	1.0	10	12	6	8	8	4.0
2.2	F	CWR06N@225#*	2.0	20	24	6	8	8	2.5
3.3	G	CWR06N@335#*	2.0	20	24	6	8	8	2.0
4.7	H	CWR06N@475#*	3.0	30	36	6	8	8	1.5

@ = Termination Finish: B = Gold (standard), H = solder Plated, C = Hot solder dipped
 # = Cap.Tolerance: J = 5%, K = 10%, M = 20%.
 * = Failure Rate B, C Weibull
 M, P, R, S Exponential



PERFORMANCE CHARACTERISTICS

1. **Operating Temperature:** Capacitors are designed to operate over the temperature range - 55°C to + 85°C.

1.1 Capacitors may be operated to + 125°C with voltage derating to two-thirds the + 85°C rating.

+ 85°C Rating		+ 125°C Rating	
Working Voltage (V)	Surge Voltage (V)	Working Voltage (V)	Surge Voltage (V)
4	5	2.7	3.4
6	8	4	5
10	13	7	9
15	20	10	12
20	26	13	16
25	32	17	20
35	46	23	28
50	65	33	38

2. **DC Working Voltage:** The DC working voltage is the maximum operating voltage for continuous duty at the rated temperature.

3. **Surge Voltage:** The surge DC rating is the maximum voltage to which the capacitors may be subjected under any conditions, including transients and peak ripple at the highest line voltage.

3.1 **Surge Voltage Test:** Capacitors shall withstand the surge voltage applied in series with a 33 ohm ± 5% resistor at the rate of one-half minute on, one-half minute off, at + 85°C, for 1000 successive test cycles.

3.2 Following the surge voltage test, the dissipation factor and the leakage current shall meet the initial requirements; the capacitance shall not have changed more than ± 10%.

4. **Capacitance Tolerance:** The capacitance of all capacitors shall be within the specified tolerance limits of the normal rating.

4.1 Capacitance measurements shall be made by means of polarized capacitance bridge. The polarizing voltage shall be of such magnitude that there shall be no reversal of polarity due to the AC component. The maximum voltage applied to capacitors during measurement shall be 2 volts rms at 120 Hz at +25°C. If the AC voltage applied is less than one-half volt rms, no DC bias is required. Accuracy of the bridge shall be within ± 2%.

5. **Capacitance Change With Temperature:** The capacitance change with temperature shall not exceed the following percentage of the capacitance measured at + 25°C:

- 55°C	+ 85°C	+ 125°C
- 10%	+ 10%	+ 15%

6. **Dissipation Factor:** The dissipation factor, determined from the expression $2\pi fRC$, shall not exceed values listed in the Standard Ratings Table.

6.1 Measurements shall be made by the bridge method at, or referred to, a frequency of 120 Hz and a temperature of + 25°C.

7. **Leakage Current:** Measurements shall be made at rated working voltage with an application of a steady source of power, such as a regulated power supply. A 1000 ohm resistor to limit the charging current shall be connected in series with each capacitor under test. Rated working voltage shall be applied to capacitors for 5 minutes before making leakage current measurements. Units must be stabilized at the rated temperature for 30 minutes prior to application of voltage.

Note that the leakage current varies with temperature and applied voltage. See graph below for the appropriate adjustment factor.

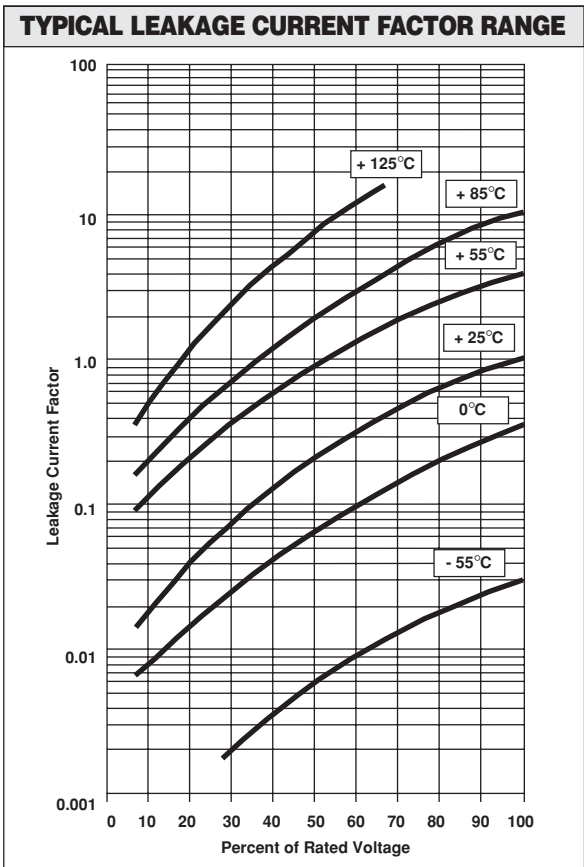

PERFORMANCE CHARACTERISTICS (Continued)

- 7.1** At + 25°C, when measured at + 25°C ± 5°C, the leakage current for any capacitor shall not exceed the maximum value listed in the Standard Ratings Table
- 7.2** At + 85°C, when measured at + 85°C ± 5°C, the leakage current for any capacitor shall not exceed the maximum value listed in the Standard Ratings Table.
- 7.3** At + 125°C, when measured at + 125°C ± 5°C, the leakage current for any capacitor shall not exceed the maximum value listed in the Standard Ratings Table.
- 8. Life Test:** Capacitors shall be capable of withstanding a 2000 hour life test at the + 85°C rated DC working voltage or a 2000 hour life test at the + 125°C derated working voltage.
- 8.1** Following the life test, the capacitors shall meet the following requirements: the capacitance at + 25°C shall not have changed by more than ± 10% from the

initial value; the dissipation factor shall meet the initial requirements; the leakage current shall not be more than the original requirements.

- 9. Reflow Soldering:** It is recommended that these capacitors be reflow soldered at a temperature of not greater than + 250°C for a period of not more than 30 seconds.
- 10. Marking:** The small body area of these capacitors does not permit elaborate marking schemes. Required information will be distinctly marked on the carton or packages in which the units are shipped. Capacitors may be ordered with color coding at additional cost. Color coding shall be as mutually agreed upon by Vishay Sprague® and the customer.
- 10.1 Polarity:** The anode terminal of each capacitor is identified by the weld and dimple projection on the anode cap (see Dimensional Configurations).

GUIDE TO APPLICATION

- 1. A-C Ripple Current:** The maximum allowable ripple current shall be determined from the formula:

$$I_{rms} = \sqrt{\frac{P}{R_{ESR}}}$$

where,

P = Power Dissipation in Watts @ + 25°C as given in the table in Paragraph Number 5 (Power Dissipation).

R_{ESR} = The capacitor Equivalent Series Resistance at the specified frequency.

- 2. A-C Ripple Voltage:** The maximum allowable ripple voltage shall be determined from the formula:

$$V_{rms} = Z \sqrt{\frac{P}{R_{ESR}}}$$

or, from the formula:

$$V_{rms} = I_{rms} \times Z$$

where,

P = Power Dissipation in Watts @ + 25°C as given in the table in Paragraph Number 5 (Power Dissipation).

R_{ESR} = The capacitor Equivalent Series Resistance at the specified frequency.

Z = The capacitor impedance at the specified frequency.

- 2.1** The sum of the peak AC voltage plus the DC voltage shall not exceed the DC voltage rating of the capacitor.
- 2.2** The sum of the negative peak AC voltage plus the applied DC voltage shall not allow a voltage reversal exceeding 10% of the DC rating at + 25°C.
- 3. Reverse Voltage:** These capacitors are capable of withstanding peak voltages in the reverse direction equal to 10% of the DC rating at + 25°C, 5% of the DC rating at + 85°C and 1% of the DC rating at +125°C.
- 4. Temperature Derating:** If these capacitors are to be operated at temperatures above + 25°C, the permissible rms ripple current or voltage shall be calculated using the derating factors as shown:

Temperature	Derating Factor
+ 25°C	1.0
+ 55°C	0.9
+ 85°C	0.8
+ 125°C	0.4

- 5. Power Dissipation:** Power dissipation will be affected by the heat sinking capability of the mounting surface. Non-sinusoidal ripple current may produce heating effects which differ from those shown. It is important that the equivalent *I_{rms}* value be established when calculating permissible operating levels. (Power Dissipation calculated using + 25°C temperature rise.)

GUIDE TO APPLICATION (Continued)

Case Code	Maximum Permissible Power Dissipation @ + 25°C (Watts) in free air
A	0.060
B	0.075
C	0.075
D	0.085
E	0.095
F	0.110
G	0.120
H	0.150

6. Printed Circuit Board Materials: The CWR06 is compatible with commonly used printed circuit board materials (alumina substrates, FR4, FR5, G10, PTFE-fluorocarbon and porcelainized steel). If you desire other board materials, contact the factory for availability.

7. Attachment:

7.1 Solder Paste: The recommended thickness of the solder paste after application is .007" ± .001" [.178mm ± .025mm]. Care should be exercised in selecting the solder paste. The metal purity should be as high as practical. The flux (in the paste) must be active enough to remove the oxides formed on the metallization prior to the exposure to soldering heat. In practice this can be aided by extending the solder preheat time at temperatures below the liquidous state of the solder.

7.2 Soldering: Capacitors can be attached by conventional soldering techniques - vapor phase, infrared reflow, wave soldering and hot plate methods. The Soldering Profile chart shows maximum recommended time/temperature conditions for soldering. Attachment with a soldering iron is not recommended due to the difficulty of controlling temperature and time at temperature.

8. Cleaning (Flux Removal) After Soldering: The CWR06 is compatible with all commonly used solvents such as TES, TMS, Prelete, Chlorethane, Terpene and aqueous cleaning media. However, CFC/ODS products are not used in the production of these devices and are not recommended. Solvents containing methylene chloride or other epoxy solvents should be avoided since these attack the epoxy encapsulation material.

9 Recommended Mounting Pad Geometries: The area under the tantalum wire nib should not be metallized on the PC board. The width dimension indicated is the same as the maximum width of the capacitor. This is to minimize lateral movement.

REFLOW SOLDER PADS*

in inches [millimetres]

CASE CODE	WIDTH (A)	PAD METALIZATION (B)	SEPARATION (C)
A	0.65 (1.6)	0.050 (1.3)	0.040 (1.0)
B	0.065 (1.6)	0.070 (1.8)	0.055 (1.4)
C	0.065 (1.6)	0.070 (1.8)	0.120 (0.3)
D	0.115 (2.9)	0.070 (1.8)	0.070 (1.8)
E	0.115 (2.9)	0.070 (1.8)	0.120 (3.0)
F	0.150 (3.8)	0.070 (1.8)	0.140 (3.6)
G	0.125 (3.2)	0.070 (1.8)	0.170 (4.3)
H	0.165 (4.2)	0.090 (2.3)	0.170 (4.3)

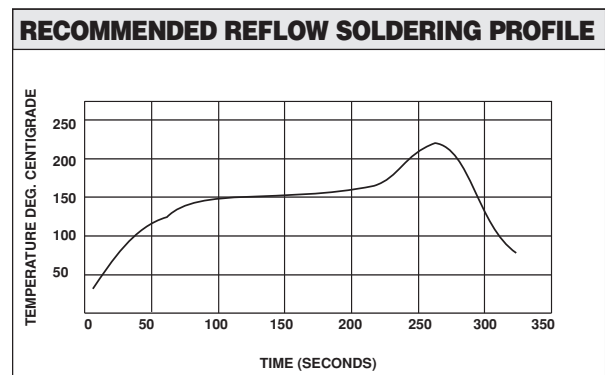

TAPE AND REEL PACKAGING

Tape and Reel Specifications: All case codes are available on plastic embossed tape per EIA-481-1 and EIA-481-2. Tape reeling per IEC 286-3 is also available. Standard reel diameter is 7" [178mm]. 13" [330mm] reels are available and recommended as the most cost effective packaging method. The most efficient packaging quantities are full reel increments on a given reel diameter. The quantities shown allow for the sealed empty pockets required to be in conformance with EIA-481-1 and EIA-481-2. Reel size and packaging orientation must be specified in the Vishay Sprague part number.

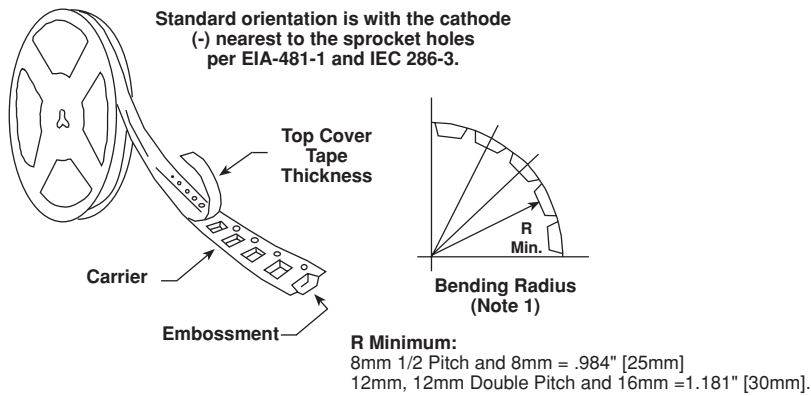
Notes:

1. 12mm and 16mm embossed tape with components shall pass around radius "R" without damage. The minimum trailer length may require additional length to provide R minimum for reels with hub diameters approaching N minimum.

Case Code	Tape Width	Component Pitch	Units Per Reel		Minimum Quantity Per Reel
			7" [178] Reel	13" [330] Reel	
A	8mm	4mm	2500	10,000	1250
B	12mm	4mm	2500	10,000	1250
C	12mm	4mm	2500	10,000	1250
D	12mm	4mm	2500	10,000	1250
E	12mm	4mm	2500	10,000	1250
F	12mm	8mm	1000	4000	500
G	16mm	8mm	600	2500	300
H	16mm	8mm	600	2500	300