



# 1Kx4 Static RAM

## Features

- Memory reset function
- 1024 x 4 static RAM for control store in high-speed computers
- CMOS for optimum speed/power
- High speed
  - 10 ns (commercial)
  - 12 ns (military)
- Low power
  - 495 mW (commercial)
  - 550 mW (military)
- Separate inputs and outputs
- 5-volt power supply  $\pm 10\%$  tolerance in both commercial and military
- Capable of withstanding greater than 2001V static discharge
- TTL-compatible inputs and outputs

## Functional Description

The CY7C150 is a high-performance CMOS static RAM designed for use in cache memory, high-speed graphics, and data-acquisition applications. The CY7C150 has a memory reset feature that allows the entire memory to be reset in two memory cycles.

Separate I/O paths eliminates the need to multiplex data in and data out, providing for simpler board layout and faster system performance. Outputs are three-stated during write, reset, deselect, or when output enable ( $\overline{OE}$ ) is held HIGH, allowing for easy memory expansion.

Reset is initiated by selecting the device ( $\overline{CS} = \text{LOW}$ ) and taking the reset ( $\overline{RS}$ ) input LOW. Within two memory cycles all bits are internally cleared to zero. Since chip select must be LOW for the device to be reset, a global reset signal can be employed, with only selected devices being cleared at any given time.

Writing to the device is accomplished when the chip select ( $\overline{CS}$ ) and write enable ( $\overline{WE}$ ) inputs are both LOW. Data on the four data inputs ( $D_0$ – $D_3$ ) is written into the memory location specified on the address pins ( $A_0$  through  $A_9$ ).

Reading the device is accomplished by taking chip select ( $\overline{CS}$ ) and output enable ( $\overline{OE}$ ) LOW while write enable ( $\overline{WE}$ ) remains HIGH. Under these conditions, the contents of the memory location specified on the address pins will appear on the four output pins ( $O_0$  through  $O_3$ ).

The output pins remain in high-impedance state when chip enable ( $\overline{CE}$ ) or output enable ( $\overline{OE}$ ) is HIGH, or write enable ( $\overline{WE}$ ) or reset ( $\overline{RS}$ ) is LOW.

A die coat is used to insure alpha immunity.

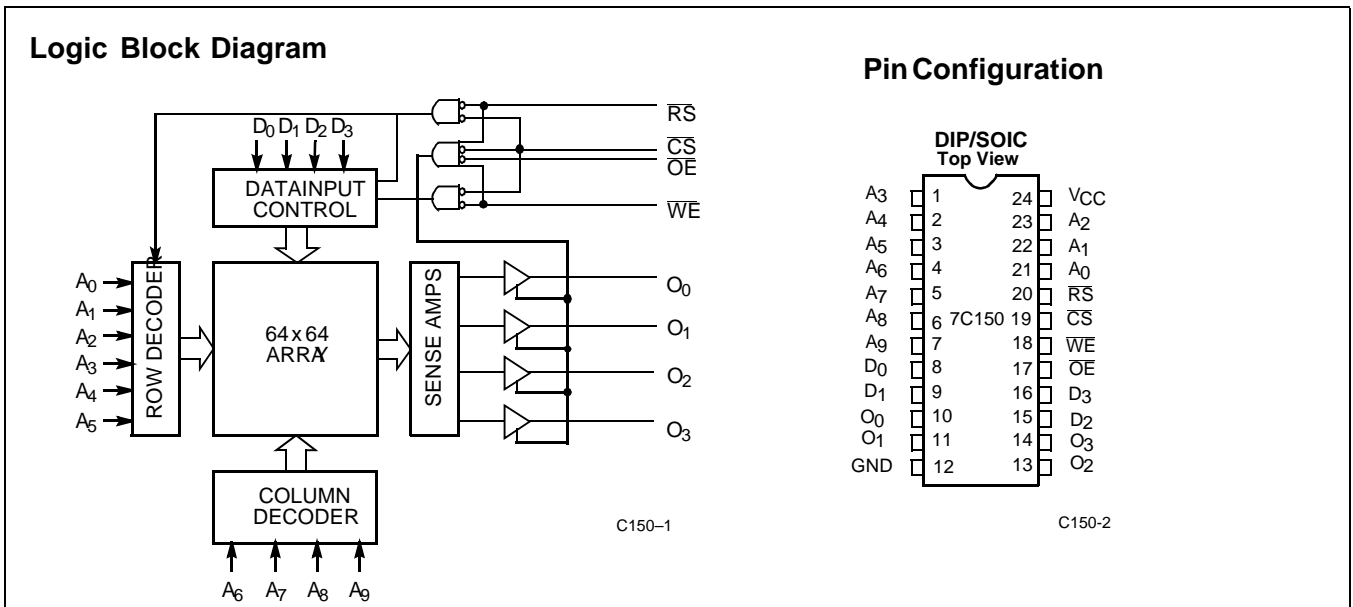

## Selection Guide

		7C150-10	7C150-12	7C150-15	7C150-25	7C150-35
Maximum Access Time (ns)	Commercial	10	12	15	25	
	Military		12	15	25	35
Maximum Operating Current (mA)	Commercial	90	90	90	90	90
	Military		100	100	100	100

### Maximum Ratings

(Above which the useful life may be impaired. For user guidelines, not tested.)

Storage Temperature .....	-65°C to +150°C
Ambient Temperature with Power Applied.....	-55°C to +125°C
Supply Voltage to Ground Potential (Pin 24 to Pin 12).....	-0.5V to +7.0V
DC Voltage Applied to Outputs in High Z State .....	-0.5V to +7.0V
DC Input Voltage .....	-3.0V to +7.0V
Output Current into Outputs (LOW) .....	20 mA

Static Discharge Voltage ..... >2001V  
(per MIL-STD-883, Method 3015)

Latch-Up Current..... >200 mA

### Operating Range

Range	Ambient Temperature	V <sub>CC</sub>
Commercial	0°C to +70°C	5V ± 10%
Military <sup>[1]</sup>	-55°C to +125°C	5V ± 10%

**Note:**

1. T<sub>A</sub> is the "instant on" case temperature.

### Electrical Characteristics Over the Operating Range<sup>[2]</sup>

Parameter	Description	Test Conditions	7C150		Unit
			Min.	Max.	
V <sub>OH</sub>	Output HIGH Voltage	V <sub>CC</sub> = Min., I <sub>OH</sub> = -0.4 mA	2.4		V
V <sub>OL</sub>	Output LOW Current	V <sub>CC</sub> = Min., I <sub>OL</sub> = 12 mA		0.4	V
V <sub>IH</sub>	Input HIGH Level		2.0	V <sub>CC</sub>	V
V <sub>IL</sub>	Input LOW Level		-3.0	0.8	V
I <sub>Ix</sub>	Input Load Current	GND ≤ V <sub>I</sub> ≤ V <sub>CC</sub>	-10	+10	μA
I <sub>OZ</sub>	Output Current (High Z)	V <sub>OL</sub> ≤ V <sub>OUT</sub> ≤ V <sub>OH</sub> , Output Disabled	-50	+50	μA
I <sub>OS</sub>	Output Short Circuit Current <sup>[3]</sup>	V <sub>CC</sub> = Max., V <sub>OUT</sub> = GND		-300	mA
I <sub>CC</sub>	V <sub>CC</sub> Operating Supply Current	V <sub>CC</sub> = Max., I <sub>OUT</sub> = 0 mA	Commercial	90	mA
			Military	100	mA

**Notes:**

- See the last page of this specification for Group A subgroup testing information.
- Not more than 1 output should be shorted at a time. Duration of the short circuit should not exceed 30 seconds.

### Capacitance<sup>[4]</sup>

Parameter	Description	Test Conditions	Max.	Unit
C <sub>IN</sub>	Input Capacitance	T <sub>A</sub> = 25°C, f = 1 MHz, V <sub>CC</sub> = 5.0V	10	pF
C <sub>OUT</sub>	Output Capacitance		10	pF

**Note:**

- Tested initially and after any design or process changes that may affect these parameters.

### AC Test Loads and Waveforms

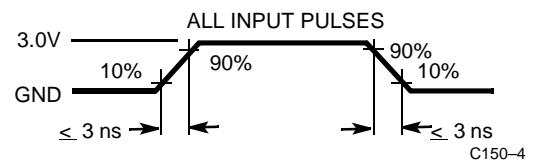
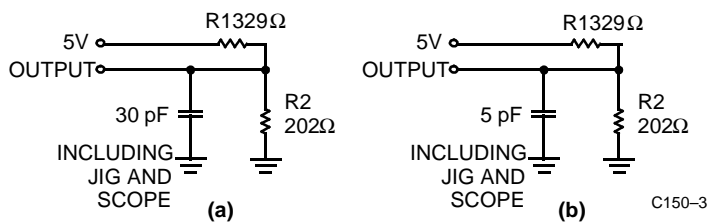

Equivalent to: THÉVENIN EQUIVALENT

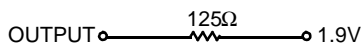

**Switching Characteristics** Over the Operating Range<sup>[2,5]</sup>

Parameter	Description	7C150-10		7C150-12		7C150-15		7C150-25		7C150-35		Unit
		Min.	Max.	Min.	Max.	Min.	Max.	Min.	Max.	Min.	Max.	
<b>READ CYCLE</b>												
t <sub>RC</sub>	Read Cycle Time	10		12		15		25		35		ns
t <sub>AA</sub>	Address to Data Valid		10		12		15		25		35	ns
t <sub>OHA</sub>	Output Hold from Address Change	2		2		2		2		2		ns
t <sub>ACS</sub>	CS LOW to Data Valid		8		10		12		15		20	ns
t <sub>LZCS</sub>	CS LOW to Low Z <sup>[6]</sup>	0		0		0		0		0		ns
t <sub>HZCS</sub>	CS HIGH to High Z <sup>[6,7]</sup>		6		8		11		20		25	ns
t <sub>DOE</sub>	OE LOW to Data Valid		6		8		10		15		20	ns
t <sub>LZOE</sub>	OE LOW to Low Z <sup>[6]</sup>	0		0		0		0		0		ns
t <sub>HZOE</sub>	OE HIGH to High Z <sup>[6,7]</sup>		6		8		9		20		25	ns
<b>WRITE CYCLE<sup>[8]</sup></b>												
t <sub>WC</sub>	Write Cycle Time	10		12		15		25		35		ns
t <sub>SCS</sub>	CS LOW to Write End	6		8		11		15		20		ns
t <sub>AW</sub>	Address Set-Up to Write End	8		10		13		20		30		ns
t <sub>HA</sub>	Address Hold from Write End	2		2		2		5		5		ns
t <sub>SA</sub>	Address Set-Up to Write Start	2		2		2		5		5		ns
t <sub>PWE</sub>	WE Pulse Width	6		8		11		15		20		ns
t <sub>SD</sub>	Data Set-Up to Write End	6		8		11		15		20		ns
t <sub>HD</sub>	Data Hold from Write End	2		2		2		5		5		ns
t <sub>LZWE</sub>	WE HIGH to Low Z <sup>[6]</sup>	0		0		0		0		0		ns
t <sub>HZWE</sub>	WE LOW to High Z <sup>[6,7]</sup>		6		8		12		20		25	ns
<b>RESET CYCLE</b>												
t <sub>RRC</sub>	Reset Cycle Time	20		24		30		50		70		ns
t <sub>SAR</sub>	Address Valid to Beginning of Reset	0		0		0		0		0		ns
t <sub>SWER</sub>	Write Enable HIGH to Beginning of Reset	0		0		0		0		0		ns
t <sub>SCSR</sub>	Chip Select LOW to Beginning of Reset	0		0		0		0		0		ns
t <sub>PRS</sub>	Reset Pulse Width	10		12		15		20		30		ns
t <sub>HCSR</sub>	Chip Select Hold After End of Reset	0		0		0		0		0		ns
t <sub>HWER</sub>	Write Enable Hold After End of Reset	8		12		15		30		40		ns
t <sub>HAR</sub>	Address Hold After End of Reset	10		12		15		30		40		ns
t <sub>LZRS</sub>	Reset HIGH to Output in Low Z <sup>[6]</sup>	0		0		0		0		0		ns
t <sub>HZRS</sub>	Reset LOW to Output in High Z <sup>[6,7]</sup>		6		8		12		20		25	ns

**Notes:**

- Test conditions assume signal transition times of 5 ns or less, timing reference levels of 1.5V, input pulse levels of 0 to 3.0V, and output loading of the specified I<sub>OL</sub>/I<sub>OH</sub> and 30-pF load capacitance.
- At any given temperature and voltage condition, t<sub>HZ</sub> is less than t<sub>LZ</sub> for any given device.
- t<sub>HZCS</sub>, t<sub>HZOE</sub>, t<sub>HZR</sub>, and t<sub>HZWE</sub> are tested with C<sub>L</sub> = 5 pF as in part (b) of AC Test Loads. Transition is measured ±500 mV from steady-state voltage.
- The internal write time of the memory is defined by the overlap of CS LOW and WE LOW. Both signals must be LOW to initiate a write and either signal can terminate a write by going HIGH. The data input set-up and hold timing should be reference to the rising edge of the signal that terminates the write.

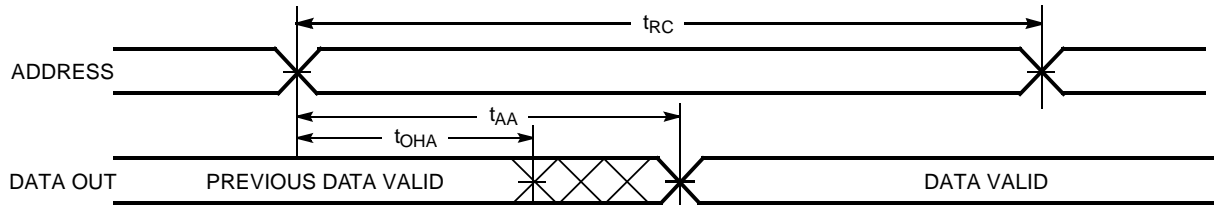
**Switching Waveforms**
**Read Cycle No.1** [9,10]

C150-5

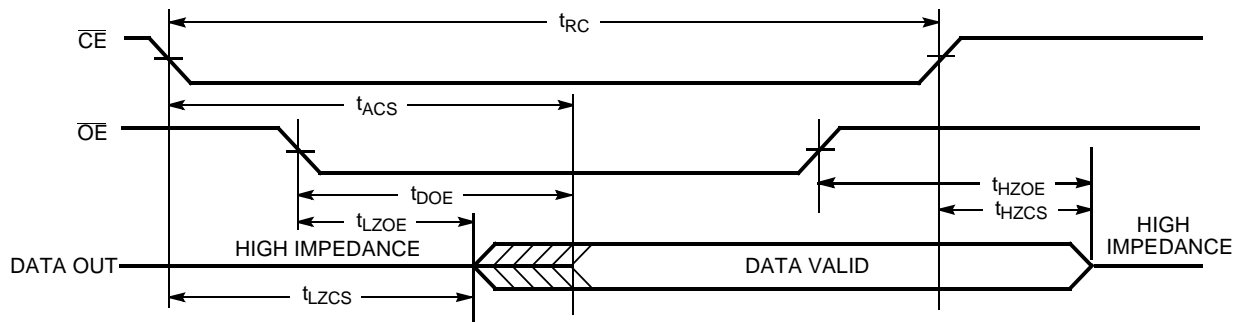
**Read Cycle No. 2** [9,11]

C150-6

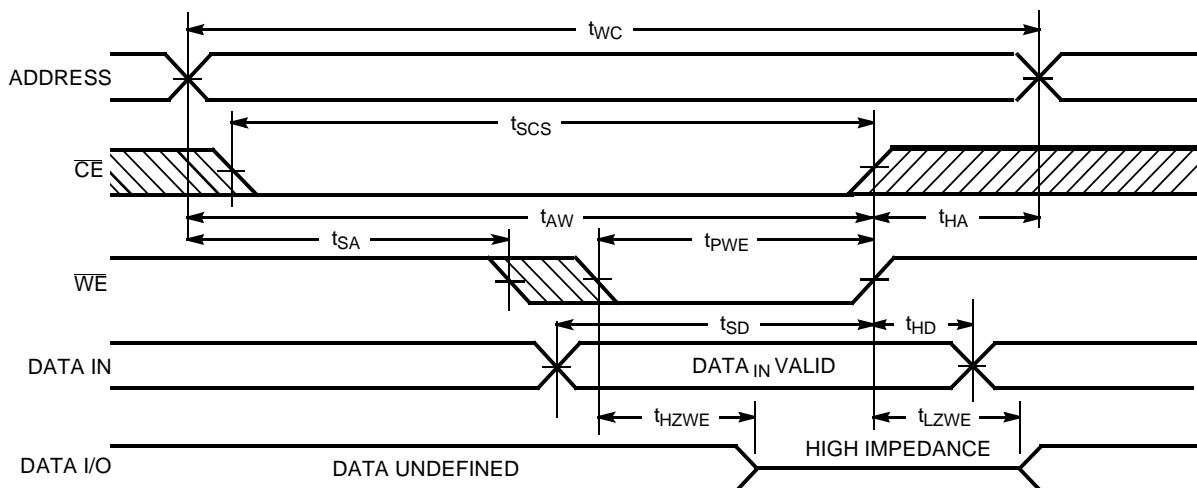
**Write Cycle No.1 ( $\overline{WE}$  Controlled)** [8]

C150-7

**Notes:**

9.  $\overline{WE}$  is HIGH for read cycle.
10. Device is continuously selected,  $\overline{CS}$  and  $\overline{OE} = V_{IL}$ .
11. Address prior to or coincident with CS transition LOW.

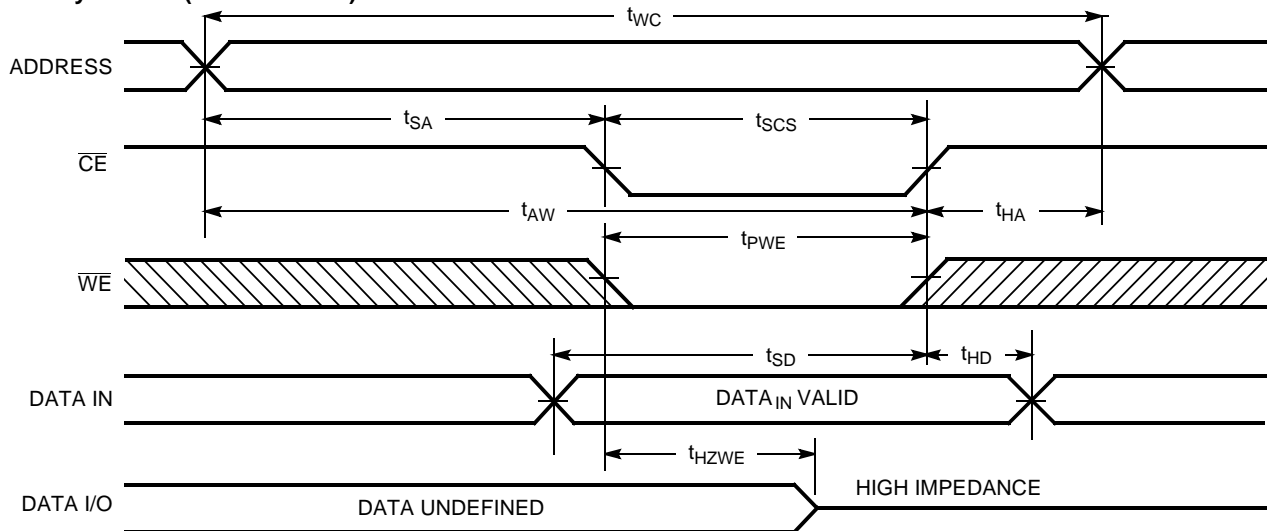
**Switching Waveforms (continued)**
**Write Cycle No2 (CS Controlled) [8,12]**

C150-8

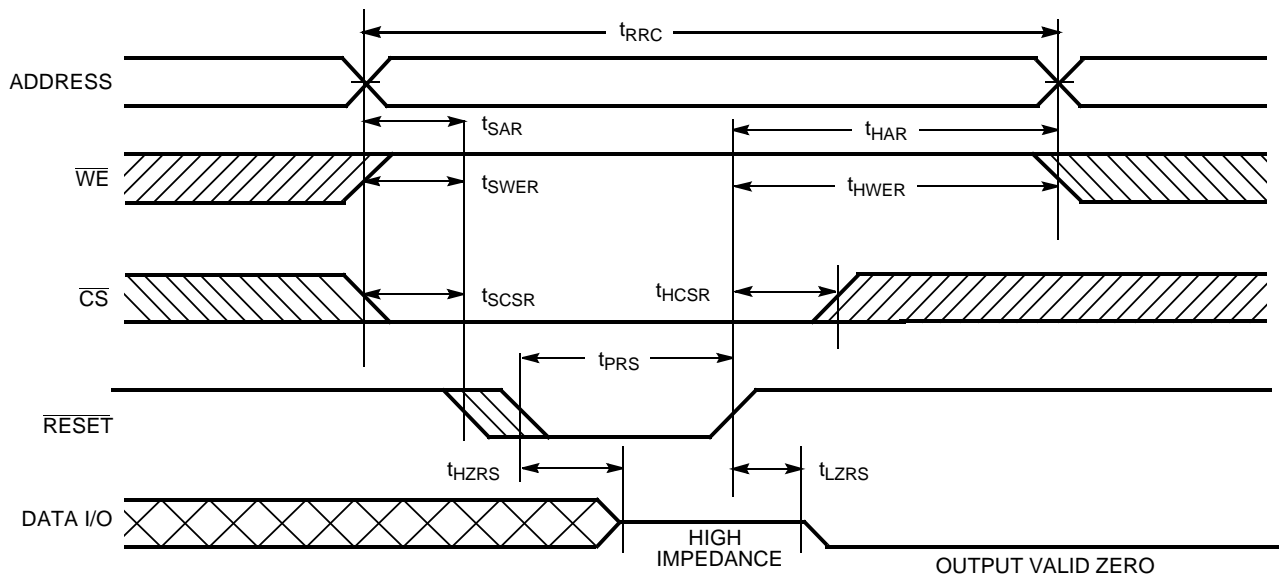
**Reset Cycle [13]**

C150-9

**Notes:**

12. If  $\overline{CS}$  goes HIGH with  $\overline{WE}$  HIGH, the output remains in a high-impedance state.
13. Reset cycle is defined by the overlap of RS and CS for the minimum reset pulse width.

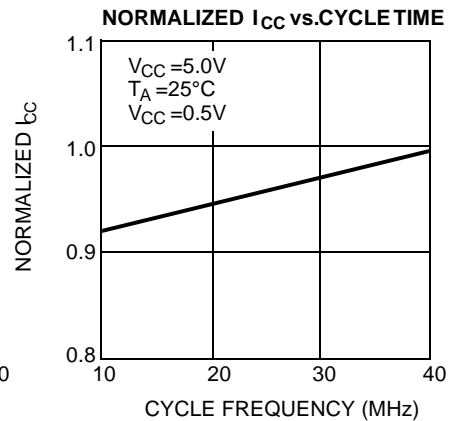
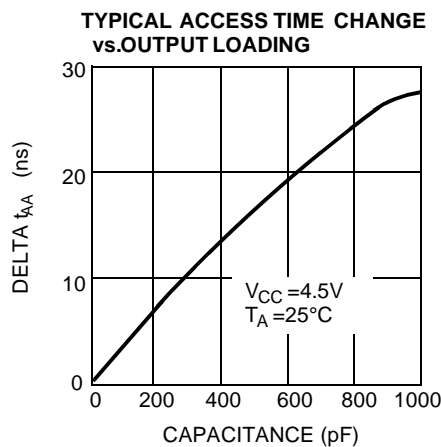
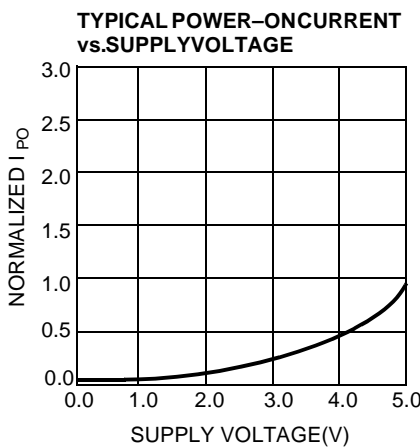
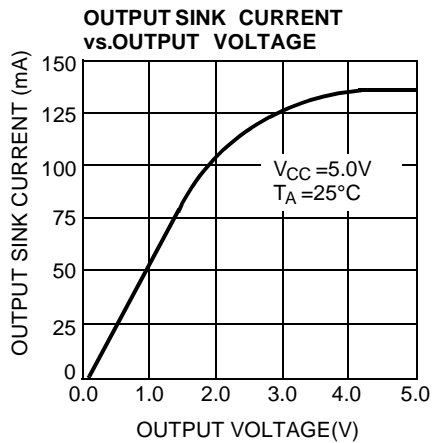
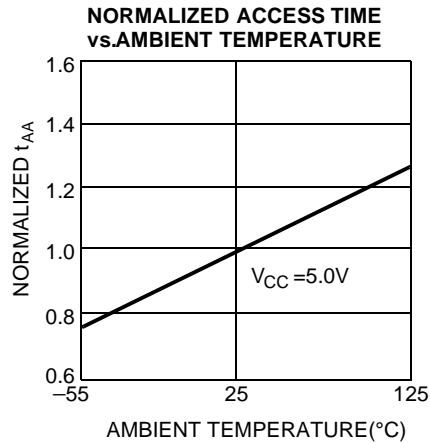
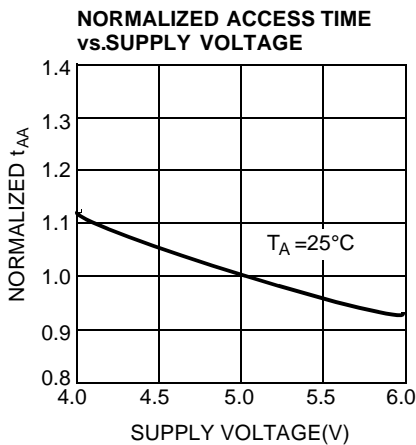
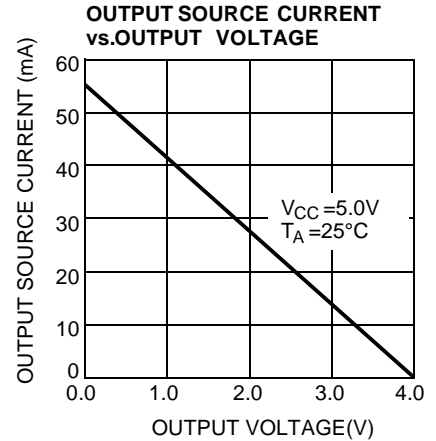
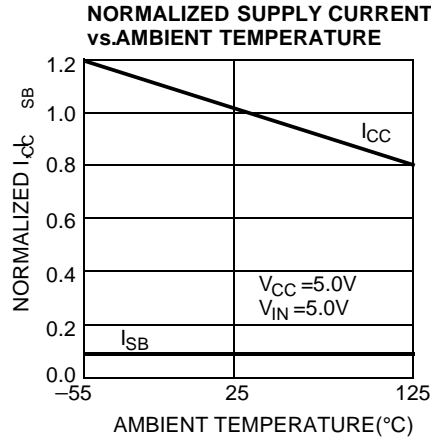
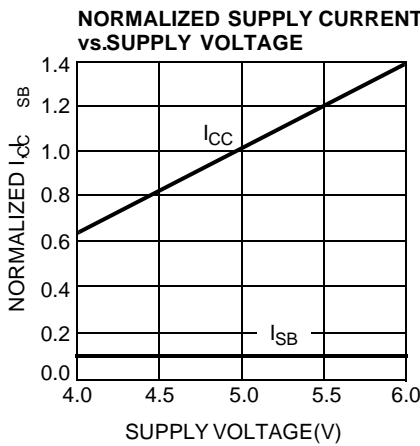
**Typical DC and AC Characteristics**

**Truth Table**

Inputs				Outputs	Mode
CS	WE	OE	RS		
H	X	X	X	High Z	Not Selected
L	H	X	L	High Z	Reset
L	L	X	H	High Z	Write
L	H	L	H	O <sub>0</sub> -O <sub>3</sub>	Read
L	X	H	H	High Z	Output Disable

**Ordering Information**

Speed (ns)	Ordering Code	Package Name	Package Type	Operating Range
10	CY7C150-10PC	P13A	24-Lead (300-Mil) Molded DIP	Commercial
	CY7C150-10SC	S13	24-Lead Molded SOIC	
12	CY7C150-12PC	P13A	24-Lead (300-Mil) Molded DIP	Commercial
	CY7C150-12SC	S13	24-Lead Molded SOIC	
	CY7C150-12DMB	D14	24-Lead (300-Mil) CerDIP	Military
15	CY7C150-15PC	P13A	24-Lead (300-Mil) Molded DIP	Commercial
	CY7C150-15SC	S13	24-Lead Molded SOIC	
	CY7C150-15DMB	D14	24-Lead (300-Mil) CerDIP	Military
25	CY7C150-25PC	P13A	24-Lead (300-Mil) Molded DIP	Commercial
	CY7C150-25SC	S13	24-Lead Molded SOIC	
	CY7C150-25DMB	D14	24-Lead (300-Mil) CerDIP	Military
35	CY7C150-35DMB	D14	24-Lead (300-Mil) CerDIP	Military

**MILITARY SPECIFICATIONS  
Group A Subgroup Testing**
**DC Characteristics**

Parameter	Subgroups
V <sub>OH</sub>	1, 2, 3
V <sub>OL</sub>	1, 2, 3
V <sub>IH</sub>	1, 2, 3
V <sub>IL</sub> Max.	1, 2, 3
I <sub>IX</sub>	1, 2, 3
I <sub>OZ</sub>	1, 2, 3
I <sub>CC</sub>	1, 2, 3

**Switching Characteristics**

Parameter	Subgroups
<b>READ CYCLE</b>	
t <sub>RC</sub>	7, 8, 9, 10, 11
t <sub>AA</sub>	7, 8, 9, 10, 11
t <sub>OHA</sub>	7, 8, 9, 10, 11
t <sub>ACS</sub>	7, 8, 9, 10, 11
<b>WRITE CYCLE</b>	
t <sub>WC</sub>	7, 8, 9, 10, 11
t <sub>SCS</sub>	7, 8, 9, 10, 11
t <sub>AW</sub>	7, 8, 9, 10, 11
t <sub>HA</sub>	7, 8, 9, 10, 11
t <sub>SA</sub>	7, 8, 9, 10, 11
t <sub>PWE</sub>	7, 8, 9, 10, 11
t <sub>SD</sub>	7, 8, 9, 10, 11
t <sub>HD</sub>	7, 8, 9, 10, 11
<b>RESET CYCLE</b>	
t <sub>RRC</sub>	7, 8, 9, 10, 11
t <sub>SAR</sub>	7, 8, 9, 10, 11
t <sub>SWER</sub>	7, 8, 9, 10, 11
t <sub>SCSR</sub>	7, 8, 9, 10, 11
t <sub>PRS</sub>	7, 8, 9, 10, 11
t <sub>HCSR</sub>	7, 8, 9, 10, 11
t <sub>HWER</sub>	7, 8, 9, 10, 11
t <sub>HAR</sub>	7, 8, 9, 10, 11



Package Diagrams

**24-Lead (300-Mil) CerDIP D14**  
MIL-STD-1835 D- 9Config.A

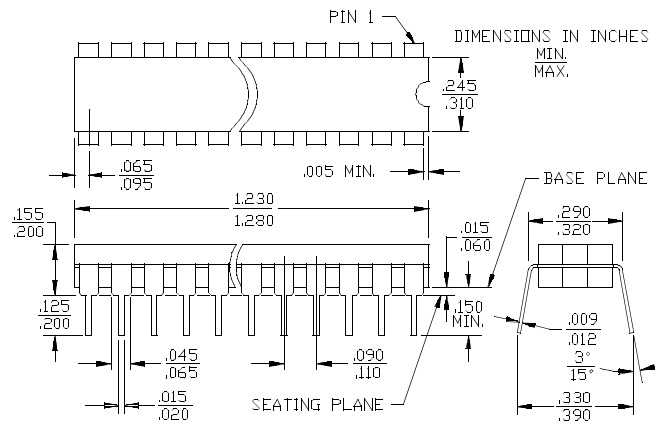

**24-Lead (300-Mil) Molded DIP P13/P13A**

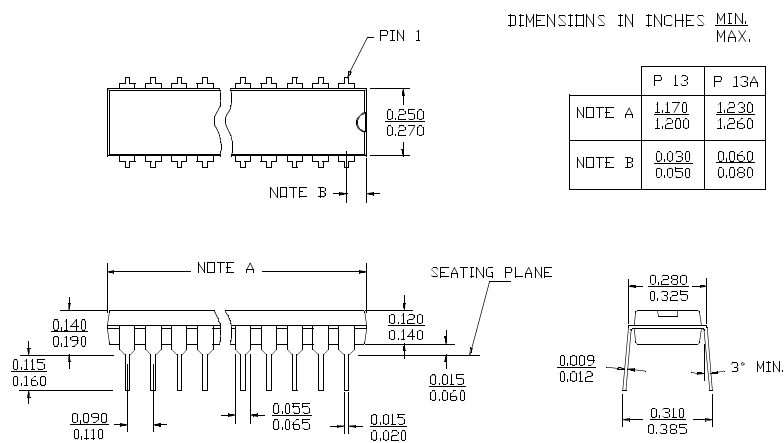

Package Diagrams (continued)

24-Lead Molded SOIC S13

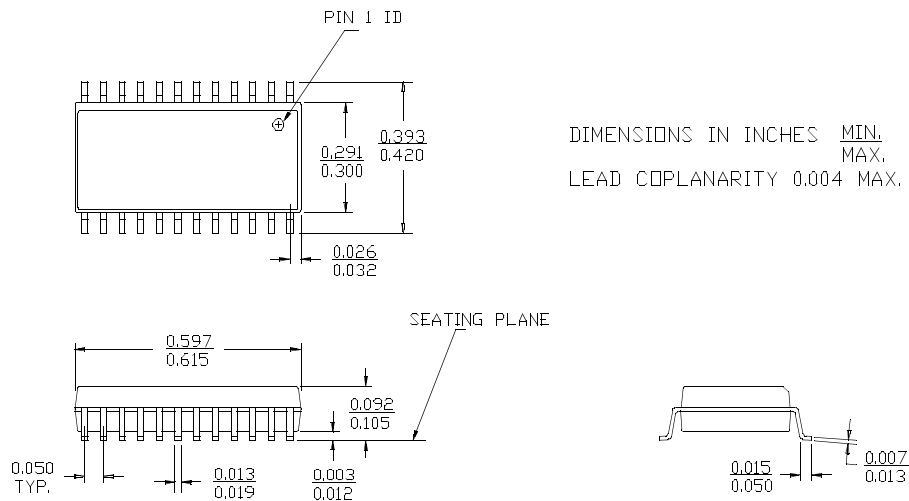



**Document Title: Cy7C150 1K x4 Static RAM**  
**Document Number: 38-05024**

<b>REV.</b>	<b>ECN NO.</b>	<b>Issue Date</b>	<b>Orig. of Change</b>	<b>Description of Change</b>
**	106810	09/10/01	SZV	Change from Spec number: 38-00028 to 38-05024