

# Synchronous-Rectified Buck MOSFET Drivers

## General Description

The RT9600 is a high frequency, dual MOSFET driver specifically designed to drive two power N-Channel MOSFETs in a synchronous-rectified buck converter topology. This driver combined with a RT9237 Multi-Phase Buck PWM controller form a complete core-voltage regulator solution for advanced microprocessors.

The RT9600 drives both the lower/upper gate in a synchronous-rectifier bridge to 12V. Independent driving of upper gate through PVCC pin is achievable. Recommended PVCC ranges are from 8 to 12V for Rds(on) concern. This drive-voltage flexibility provides the advantage of optimizing applications involving trade-offs between switching losses and conduction losses.

The output drivers in the RT9600 have the capacity to efficiently switch power MOSFETs at frequencies up to 2MHz. Each driver is capable of driving a 3000pF load with a 30ns propagation delay and 50ns transition time. RT9600 implements bootstrapping on the upper gate with only an external capacitor required. This reduces implementation complexity and allows the use of higher performance, cost effective, N-Channel MOSFETs. Adaptive shoot-through protection is integrated to prevent both MOSFETs from conducting simultaneously.

## Ordering Information

RT9600□□

- Package Type  
S : SOP-8
- Operating temperature range  
C: Commercial standard

## Features

- Drives Two N-Channel MOSFETs
- Adaptive Shoot-Through Protection
- Internal Bootstrap Device
- Supports High Switching Frequency
  - Fast Output Rise Time
  - Propagation Delay 30ns
- Small SOP-8 Package
- Dual Gate-Drive Voltages for Optimal Efficiency
- Three-State Input for Bridge Shutdown
- Supply Under Voltage Protection
- High Side Short Circuit Protection

## Applications

- Core Voltage Supplies for Intel Pentium® 4, AMD® Athlon™ Microprocessors
- High Frequency Low Profile DC-DC Converters
- High Current Low Voltage DC-DC Converters

## Pin Configurations

Part Number	Pin Configurations
RT9600CS (Plastic SOP-8)	<p style="text-align: center;">TOP VIEW</p> <p style="text-align: center;">                 UGATE [1]      [8] PHASE                  BOOT [2]      [7] PVCC                  PWM [3]      [6] VCC                  GND [4]      [5] LGATE             </p>

**Pin Description**

Pin No.	Pin Name	Pin Function
1	UGATE	Upper Gate Drive Output. Connect to gate of high-side power N-Channel MOSFET
2	BOOT	Floating bootstrap supply pin for upper gate drive.
3	PWM	Input PWM signal for controlling the driver.
4	GND	Ground
5	LGATE	Lower gate drive output. Connect to gate of low-side power N-Channel MOSFET.
6	VCC	+12V Supply Voltage
7	PVCC	Upper Gate Drive Supply Bias. Typical +12V
8	PHASE	Connect this pin to the source of the high-side MOSFET and the drain of the low-side MOSFET

**Function Block Diagram**

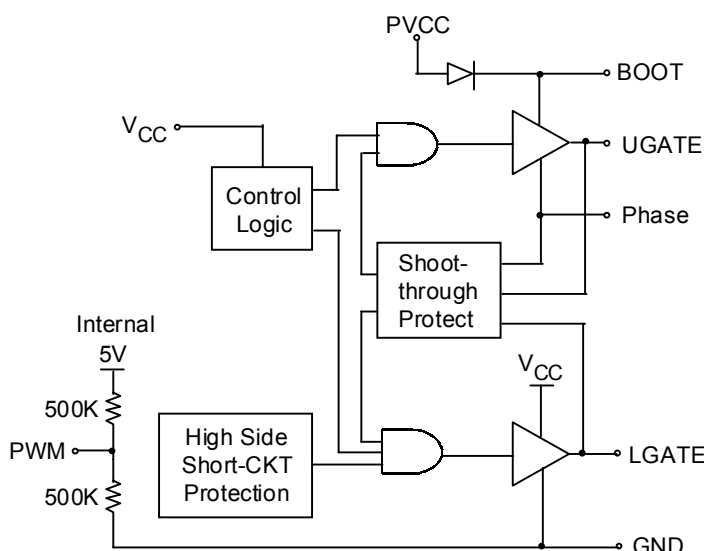

**Typical Application Circuit**

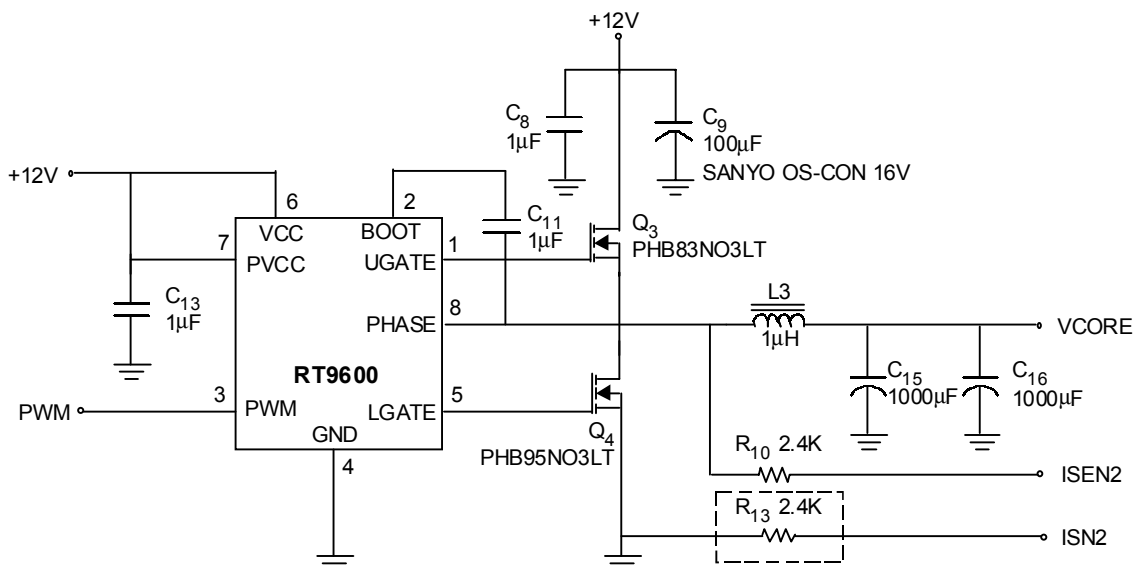

There 2 PCB trace have to parallel and place R near to PWM IC

**Absolute Maximum Ratings**

- Supply Voltage (VCC) ..... 12V
- Supply Voltage (PVCC) ..... VCC + 0.3V
- BOOT Voltage ..... 12V
- Input Voltage ..... GND – 0.3V to 7V
- UGATE ..... V<sub>PHASE</sub> – 0.3V to V<sub>BOOT</sub> + 0.3V
- LGATE ..... GND – 0.3V To V<sub>PVCC</sub> + 0.3V
- EDS Level
  - HBM ..... 2KV
  - MM ..... 200V
- Power Dissipation, P<sub>D</sub> @ T<sub>A</sub> = 25°C
  - SOP-8 ..... 0.625W
- Package Thermal Resistance
  - SOP-8, θ<sub>JA</sub> ..... 160°C /W
- Ambient Temperature Range ..... 0°C ~ 85°C
- Operating Junction Temperature ..... 125°C
- Lead Temperature (Soldering, 10 sec.) ..... 300°C
- Storage Temperature Range ..... -65°C ~ 150°C

**Electrical Characteristics**

(V<sub>IN</sub> = 5V, C<sub>IN</sub> = C<sub>OUT</sub> = 1μF, T<sub>A</sub> = 25°C, unless otherwise specified)

Parameter	Symbol	Test Conditions	Min	Typ	Max	Units
<b>VCC Supply Current</b>						
Bias Supply Current	I <sub>VCC</sub>	f <sub>PWM</sub> = 1MHz, V <sub>PVCC</sub> = 12V	--	3	--	mA
Power Supply Current	I <sub>PVCC</sub>	f <sub>PWM</sub> = 1MHz, V <sub>PVCC</sub> = 12V, C <sub>boot</sub> =0.1μF	--	1.5	--	mA
<b>Power-On Reset</b>						
VCC Rising Threshold			--	9.2	--	V
VCC Falling Threshold			--	8.1	--	V
<b>Output</b>						
Upper Drive Source	I <sub>UGATE</sub>	V <sub>VCC</sub> = 12V, V <sub>PVCC</sub> = 8V, Instantaneous	--	1.7	--	A
		V <sub>VCC</sub> = V <sub>PVCC</sub> = 12V, Instantaneous	--	3	--	
Upper Drive Sink	R <sub>UGATE</sub>	V <sub>VCC</sub> = 12V, V <sub>PVCC</sub> = 8V	--	4	--	Ω
		V <sub>VCC</sub> = 12V, V <sub>PVCC</sub> = 12V	--	2.6	--	
Lower Drive Source	I <sub>LGATE</sub>	V <sub>VCC</sub> = 12V, V <sub>PVCC</sub> = 12V, Instantaneous.	--	3	--	A
Lower Drive Sink	R <sub>LGATE</sub>	V <sub>VCC</sub> = V <sub>PVCC</sub> = 12V	--	1.3	--	Ω

*To be continued*

Parameter	Symbol	Test Conditions	Min	Typ	Max	Units
<b>PWM Input</b>						
Input Current		$V_{PWM} = 0 \text{ or } 5V$	--	15	--	$\mu A$
PWM Rising Threshold			--	3.7	--	V
PWM Falling Threshold			--	1.3	--	V
UGATE Rise Time		$V_{PVCC} = V_{VCC} = 12V, 3nF \text{ load}$	--	30	--	ns
LGATE Rise Time		$V_{PVCC} = V_{VCC} = 12V, 3nF \text{ load}$	--	30	--	ns
UGATE Fall Time		$V_{PVCC} = V_{VCC} = 12V, 3nF \text{ load}$	--	40	--	ns
LGATE Fall Time		$V_{PVCC} = V_{VCC} = 12V, 3nF \text{ load}$	--	30	--	ns
UGATE Turn-Off Propagation Delay		$V_{VCC} = V_{PVCC} = 12V, 3nF \text{ load}$	--	30	--	ns
LGATE Turn-Off Propagation Delay		$V_{VCC} = V_{PVCC} = 12V, 3nF \text{ load}$	--	20	--	ns
Shutdown Window			1.5	--	3.6	V
Shutdown Holdoff Time			--	230	--	ns

**Package Information**

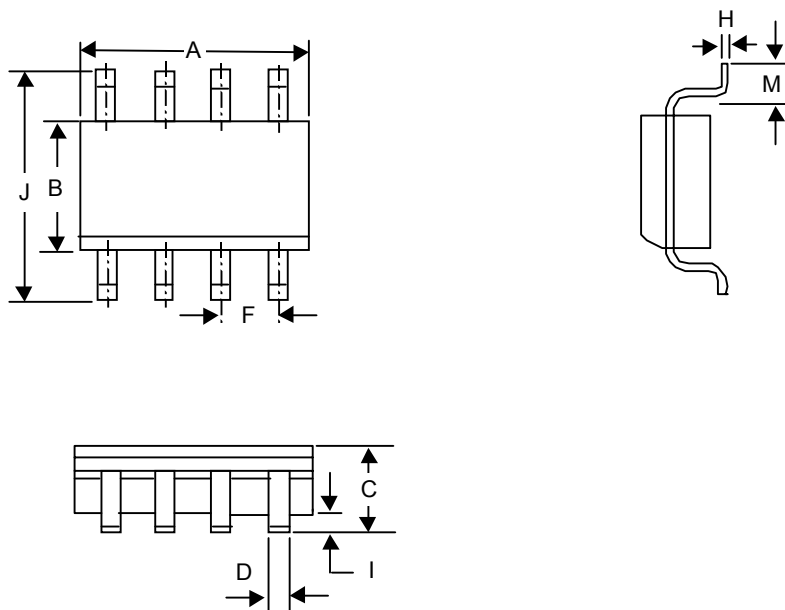

Symbol	Dimensions In Millimeters		Dimensions In Inches	
	Min	Max	Min	Max
A	4.801	5.004	0.189	0.197
B	3.810	3.988	0.150	0.157
C	1.346	1.753	0.053	0.069
D	0.330	0.508	0.013	0.020
F	1.194	1.346	0.047	0.053
H	0.178	0.254	0.007	0.010
I	0.102	0.254	0.004	0.010
J	5.791	6.198	0.228	0.244
M	0.406	1.270	0.016	0.050

**8-Lead SOP Plastic Package**

**RICHTEK TECHNOLOGY CORP.**

Headquarter

6F, No. 35, Hsintai Road, Chupei City

Hsinchu, Taiwan, R.O.C.

Tel: (8863)5510047 Fax: (8863)5537749

**RICHTEK TECHNOLOGY CORP.**

Taipei Office (Marketing)

8F-1, No. 137, Lane 235, Paochiao Road, Hsintien City

Taipei County, Taiwan, R.O.C.

Tel: (8862)89191466 Fax: (8862)89191465

Email: [marketing@richtek-ic.com.tw](mailto:marketing@richtek-ic.com.tw)