

Wirewound Resistors, Military/Established Reliability

MIL-PRF-39009 Qualified, Type RER, R Level

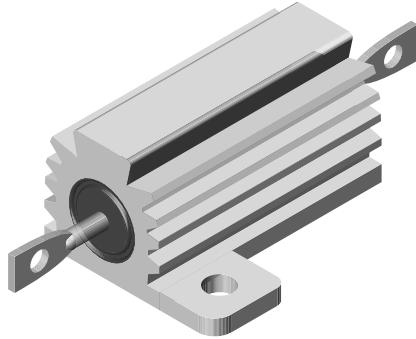

FEATURES

- Aluminum heat sink housing
- Molded construction for total environmental protection
- Qualified to MIL-PRF-39009
- Complete welded construction
- Available in non-inductive styles (type ENH) with Ayrton-Perry winding for lowest reactive components
- Mounts on chassis to utilize heat-sink effect

STANDARD ELECTRICAL SPECIFICATIONS					
MODEL	MIL-PRF-39009 TYPE	POWER RATING $P_{25^{\circ}\text{C}}$ W		MILITARY RESISTANCE RANGE $\pm 1\%$ Ω	WEIGHT (Typical) g
		MOUNTED	FREE AIR		
ENH-5	RER40	5	3	1 - 1.65k	3.3
ENH-10	RER45	10	6	1 - 2.8k	8.8
ENH-25	RER50	20	8	1 - 6.04k	16.5
ENH-50	RER55	30	10	1 - 4.99k	35
ERH-5	RER60	5	3	0.10 - 3.32k	3
ERH-10	RER65	10	6	0.10 - 5.62k	6
ERH-25	RER70	20	8	0.10 - 12.1k	13
ERH-50	RER75	30	10	0.10 - 39.2k	28

TECHNICAL SPECIFICATIONS		
PARAMETER	UNIT	ERH, ENH RESISTOR CHARACTERISTICS
Temperature Coefficient	ppm/ $^{\circ}\text{C}$	± 100 for 0.1 Ω to 0.99 Ω , ± 50 for 1 Ω to 19.9 Ω , ± 20 for 20 Ω and above
Dielectric Withstanding Voltage	V_{AC}	1000 for ERH-5 ERH-10 and ERH-25, 2000 for ERH-50
Short Time Overload	-	5 x rated power for 5 seconds
Maximum Working Voltage	V	$(P \times R)^{1/2}$
Insulation Resistance	Ω	10,000 Megohm minimum dry, 1000 Megohm minimum after moisture test
Terminal Strength	lb	5 pull for ERH-5 and ERH-10, 10 pull for ERH-25 and ERH-50
Solderability	-	Meets requirements of ANSI J-STD-002
Operating Temperature Range	$^{\circ}\text{C}$	- 55/+ 250

ORDERING INFORMATION			
RER50 MILITARY TYPE	F TOLERANCE	49R9 RESISTANCE	R FAILURE RATE



DIMENSIONS

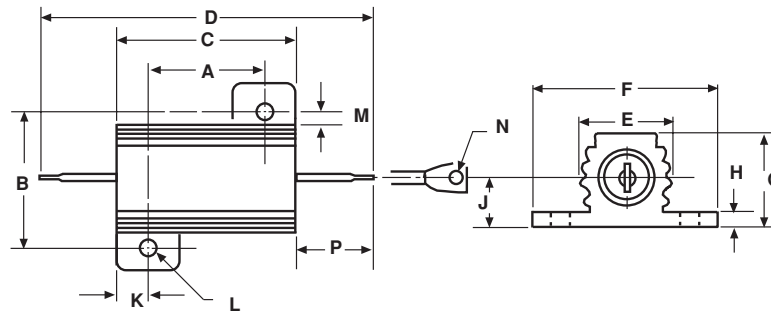

MODEL	DIMENSIONS in inches [millimeters]													
	A	B	C	D	E	F	G	H	J	K	L	M	N	P
ERH-5 ENH-5	0.444 ± 0.005 [11.280 ± 0.127]	0.490 ± 0.005 [12.450 ± 0.127]	0.600 ± 0.031 [15.240 ± 0.787]	1.125 ± 0.062 [28.580 ± 1.570]	0.334 ± 0.015 [8.480 ± 0.381]	0.646 ± 0.015 [16.410 ± 0.381]	0.320 ± 0.015 [8.130 ± 0.381]	0.065 ± 0.010 [1.650 ± 0.254]	0.133 ± 0.010 [3.380 ± 0.254]	0.078 ± 0.010 [1.980 ± 0.254]	0.093 ± 0.005 [2.360 ± 0.127]	0.078 ± 0.015 [1.980 ± 0.381]	0.050 ± 0.005 [1.270 ± 0.127]	0.266 ± 0.062 [6.760 ± 1.570]
ERH-10 ENH-10	0.562 ± 0.005 [14.270 ± 0.127]	0.625 ± 0.005 [15.880 ± 0.127]	0.750 ± 0.031 [19.050 ± 0.787]	1.375 ± 0.062 [34.930 ± 1.570]	0.420 ± 0.015 [10.670 ± 0.381]	0.800 ± 0.015 [20.320 ± 0.381]	0.390 ± 0.015 [9.910 ± 0.381]	0.075 ± 0.010 [1.900 ± 0.254]	0.165 ± 0.010 [4.190 ± 0.254]	0.093 ± 0.010 [2.360 ± 0.254]	0.094 ± 0.005 [2.390 ± 0.127]	0.102 ± 0.015 [2.590 ± 0.381]	0.085 ± 0.005 [2.160 ± 0.127]	0.312 ± 0.062 [7.920 ± 1.570]
ERH-25 ENH-25	0.719 ± 0.005 [18.260 ± 0.127]	0.781 ± 0.005 [19.840 ± 0.127]	1.062 ± 0.031 [26.970 ± 0.787]	1.938 ± 0.062 [49.230 ± 1.570]	0.550 ± 0.015 [13.970 ± 0.381]	1.080 ± 0.015 [27.430 ± 0.381]	0.546 ± 0.015 [13.870 ± 0.381]	0.075 ± 0.010 [1.900 ± 0.254]	0.231 ± 0.010 [5.870 ± 0.254]	0.172 ± 0.010 [4.370 ± 0.254]	0.125 ± 0.005 [3.180 ± 0.127]	0.115 ± 0.015 [2.920 ± 0.381]	0.085 ± 0.005 [2.160 ± 0.127]	0.438 ± 0.062 [11.130 ± 1.570]
ERH-50 ENH-50	1.562 ± 0.005 [39.670 ± 0.127]	0.844 ± 0.005 [21.440 ± 0.127]	1.968 ± 0.031 [49.990 ± 0.787]	2.781 ± 0.062 [70.640 ± 1.570]	0.630 ± 0.015 [16.000 ± 0.381]	1.140 ± 0.015 [28.960 ± 0.381]	0.610 ± 0.015 [15.490 ± 0.381]	0.088 ± 0.010 [2.240 ± 0.254]	0.260 ± 0.010 [6.600 ± 0.254]	0.196 ± 0.010 [4.980 ± 0.254]	0.125 ± 0.005 [3.180 ± 0.127]	0.107 ± 0.015 [2.720 ± 0.381]	0.085 ± 0.005 [2.160 ± 0.127]	0.438 ± 0.062 [11.130 ± 1.570]

MATERIAL SPECIFICATIONS

Element: Copper-nickel alloy or nickel-chrome alloy, depending on resistance value

Core: Ceramic, steatite or alumina, depending on physical size

Encapsulant: Silicone molded construction

Housing: Aluminum with hard anodic coating

End Caps: Stainless steel

Standard Terminals: Tinned Copperweld®

Part Marking: Source Code, JAN, Military PIN, Date/Lot Code

APPLICABLE MIL SPECIFICATION

MIL-PRF-39009: This is the military specification covering housed chassis mount established reliability power wirewound resistors. Vishay ERH and ENH resistors are listed as qualified on the MIL-PRF-39009 QPL.

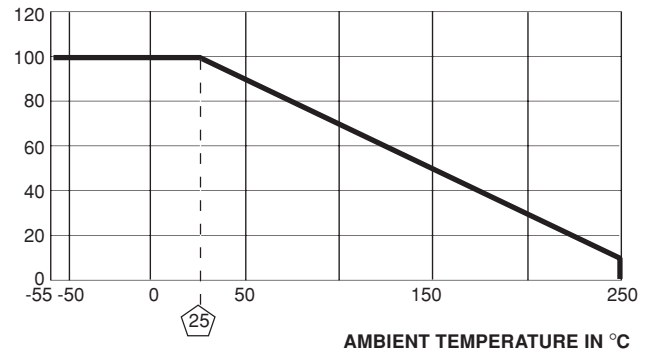

Derating

POWER RATING

Vishay ERH and ENH resistor wattage ratings are based on mounting to the proper heat sink.

ERH-5 and ERH-10: 4" x 6" x 2" x 0.040" thick aluminum chassis

ERH-25 and ERH-50: 5" x 7" x 2" x 0.040" thick aluminum chassis

PERFORMANCE		
TEST	CONDITIONS OF TEST	TEST LIMITS
Low Temperature Operation	Apply rated power until thermal stability, remove power subject to air temperature of - 55°C for 15 to 30 minutes	± (0.5% + 0.01Ω) ΔR
Short Time Overload	5 x rated power for 5 seconds	± (0.3% + 0.01Ω) ΔR
Dielectric Withstanding Voltage	1000Vrms (RER 40, 45, 50, 60, 65, 70), 2000Vrms (RER55 and 75), one minute duration	± (0.2% + 0.01Ω) ΔR
Low Temperature Storage	- 55°C for 24 hours	± (0.3% + 0.01Ω) ΔR
High Temperature Exposure	250°C for 2000 hours	± (1.0% + 0.01Ω) ΔR
Moisture Resistance	MIL-STD-202 Method 106	± (0.5% + 0.01Ω) ΔR
Shock, Specified Pulse	MIL-STD-202 Method 213, Condition 1	± (0.2% + 0.01Ω) ΔR
Vibration, High Frequency	MIL-STD-202, Method 204, Condition D	± (0.2% + 0.01Ω) ΔR
Load Life	2000 hours at rated power, + 25°C, 1.5 hours "ON", 0.5 hours "OFF"	± (1.0% + 0.01Ω) ΔR
Extended Life	10,000 hours at rated power, + 25°C, 1.5 hours "ON", 0.5 hours "OFF"	± (2.0% + 0.01Ω) ΔR
Terminal Strength	MIL-STD-202, Method 211, Condition A 5 pound (RER40, 45, 60, 65), 10 pound (RER50, 55, 70, 75)	± (0.2% + 0.01Ω) ΔR