

L8583D Line Card Access Switch

Features

- Small size/surface-mount packaging
- Monolithic IC reliability
- Low impulse noise
- Make-before-break, break-before-make operation
- Clean, bounce-free switching
- Low, matched on-resistance
- Built-in current limiting, thermal shutdown, and SLIC protection
- 5 V only operation, very low power consumption
- Battery monitor, all-off state upon loss of battery
- No EMI
- Latched logic level inputs, no driver circuitry
- Only one external protector required

Applications

- Central office
- DLC
- PBX
- DAML
- HFC/FITL

Description

The Agere Systems Inc. L8583D line card access switch is a monolithic solid-state device providing the equivalent switching functionality of three 2-form C switches. The L8583D is designed to provide power ringing access, line test access (test out), and SLIC test access (test in) to tip and ring in central office, digital loop carrier, private branch exchange, digitally added main line, and hybrid fiber coax/fiber-in-the-loop analog line card applications. An additional pair of solid-state contacts are also available to provide access for testing of the ringing generator.

The L8583D has eight states: the idle talk state (line break switches closed, all other switches open), the power ringing state (ringing access switches closed, all other switches open), loop access state (loop access switches closed, all switches open), SLIC test state (test in switches closed, all other switches open), simultaneous loop and SLIC access state (loop and test in switches closed, all others open), ringing generator test state (ring test switches closed, all others open), simultaneous test-out and ring-test state (ring and test out switches closed), and an all-off state. The L8583D is appropriate for central office, access, digital loop carrier, and other *Telcordia Technologies*[™] TR-57 applications.

The L8583D offers break-before-make or make-before-break switching, with simple logic-level input control. Because of the solid-state construction, voltage transients generated when switching into an inductive ringing lead during ring cadence or ring trip are minimized, possibly eliminating the need for external zero cross switching circuitry. State control is via logic level inputs, so no additional driver circuitry is required.

The line break switch is a linear switch that has exceptionally low on-resistance and an excellent on-resistance matching characteristic. The ringing access switch has a breakdown voltage rating >480 V which is sufficiently high, with proper protection, to prevent breakdown in the presence of a transient fault condition (i.e., passing the transient on to the ringing generator).

The L8583D provides an integrated diode bridge along with current limiting and thermal shutdown for protection of the device itself and the subsequent subscriber line integrated circuit (SLIC). For LCAS protection, power cross is reduced by the current-limiting and thermal shutdown circuits and lightning reduced by the current-limit circuit. Residue faults are shunted from the SLIC by the diode bridge.

Description (continued)

To protect the L8583D from an overvoltage fault condition, use of a secondary protector is required. The secondary protector must limit the voltage seen at the tip/ring terminals to prevent the breakdown voltage of the switches from being exceeded. To minimize stress on the solid-state contacts, use of a foldback-type or crowbar-type secondary protector is recommended. Please contact your Agere account representative for a choice of recommended secondary protection device. With proper choice of secondary protection, a line card using the L8583D will meet all relevant ITU-T, LSSGR, FCC, or *UL*[®] protection requirements.

The L8583D operates off of a 5 V supply only. This gives the device extremely low idle and active power dissipation and allows use with virtually any range of battery voltage. This makes the L8583D especially appropriate for remote power applications such as DAML or FOC/FITL or other *Telcordia Technologies* GR 909 applications where power dissipation is particularly critical.

A battery voltage is also used by the L8583D, only as a reference for the integrated protection circuit. The L8583D will enter an all-off state upon loss of battery.

During power ringing, to turn on and maintain the on state, the ring access switch and ring test switch will draw a nominal 2 mA from the ring generator.

The L8583D device is packaged in a 20-pin plastic SOG (L8583DEY) and a 28-pin plastic SOG (L8583DAE). See Figure 1 for an illustration of the 20-pin package and Figure 2 for an illustration of the 28-pin package.

Pin Information

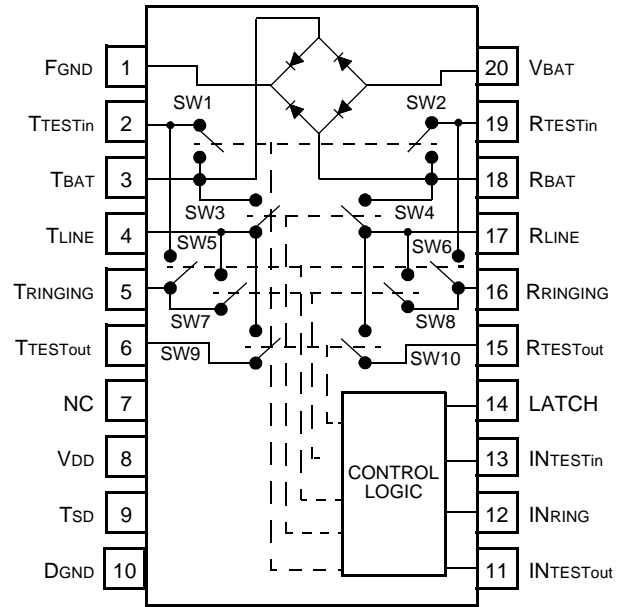

1670

Figure 1. 20-Pin Plastic SOG

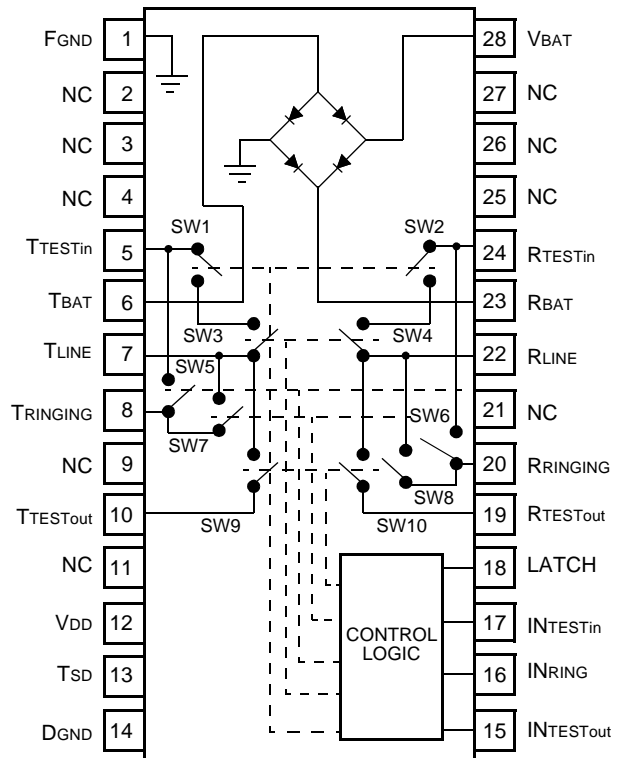

12-2365 (F).d

Figure 2. 28-Pin Plastic SOG

Idle, or Talk State Application

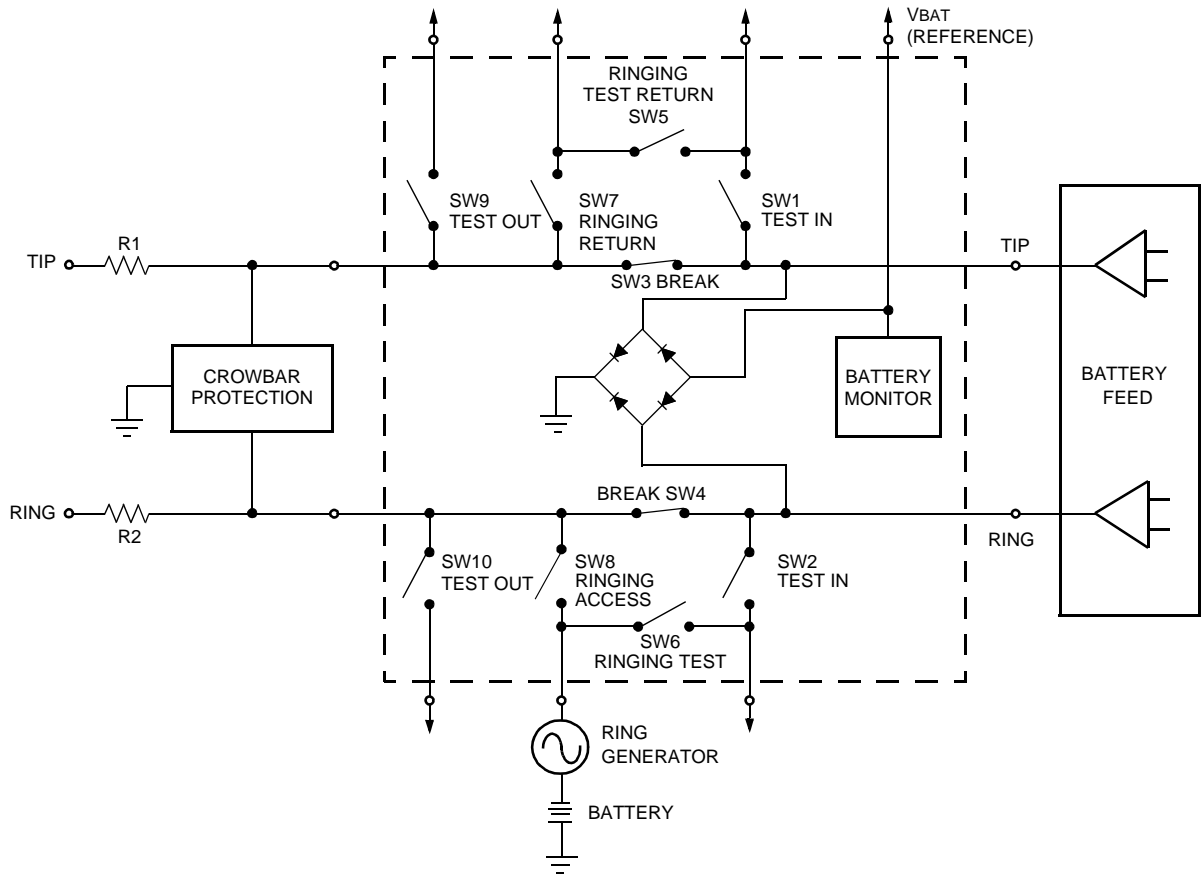

12-2366 (F).g

Telcordia Technologies is a trademark of Telcordia Technologies, Inc.
UL is a registered trademark of Underwriters Laboratories, Inc.

For additional information, contact your Agere Systems Account Manager or the following:

INTERNET: <http://www.agere.com>

E-MAIL: docmaster@agere.com

N. AMERICA: Agere Systems Inc., 555 Union Boulevard, Room 30L-15P-BA, Allentown, PA 18109-3286

1-800-372-2447, FAX 610-712-4106 (In CANADA: **1-800-553-2448**, FAX 610-712-4106)

ASIA: Agere Systems Hong Kong Ltd., Suites 3201 & 3210-12, 32/F, Tower 2, The Gateway, Harbour City, Kowloon

Tel. (852) 3129-2000, FAX (852) 3129-2020

CHINA: **(86) 21-5047-1212** (Shanghai), **(86) 10-6522-5566** (Beijing), **(86) 755-25881122** (Shenzhen)

JAPAN: **(81) 3-5421-1600** (Tokyo), KOREA: **(82) 2-767-1850** (Seoul), SINGAPORE: **(65) 6778-8833**, TAIWAN: **(886) 2-2725-5858** (Taipei)

EUROPE: **Tel. (44) 7000 624624**, FAX (44) 1344 488 045

Agere Systems Inc. reserves the right to make changes to the product(s) or information contained herein without notice. No liability is assumed as a result of their use or application.
Agere, Agere Systems, and the Agere logo are trademarks of Agere Systems Inc.

Copyright © 2002 Agere Systems Inc.
All Rights Reserved

June 2002
PB02-106ALC

agere systems