

LPC Media Center Consumer IR Controller with Windows[®] Vista[™] Remote Control Support

PRODUCT FEATURES

Data Brief

- 3.3 Volt Operation (5V Tolerant)
- Programmable Wakeup Event Interface (IO_PME# Pin)
- SMI Support (IO_SMI# Pin)
- GPIOs (14)
- Two IRQ Input Pins
- XNOR Chain
- PC99a, PC2001
- ACPI 2.0 Compliant
- 64-pin STQFP Lead-free RoHS Compliant Package
- Intelligent Auto Power Management
- Serial Ports
 - One Full Function Serial Port
 - High Speed 16C550A Compatible UART with Send/Receive 16-Byte FIFO
 - Supports 230k and 460k Baud
 - Programmable Baud Rate Generator
 - Modem Control Circuitry
- Infrared Communications Controllers
 - Two IR Ports
 - Multi-Protocol Serial Communications Controllers
 - One IrDA v1.2 (4Mbps), HPSIR, ASKIR, Consumer IR Support
 - One Consumer IR Port (CIRCC3) with Support for NEC PPM, Phillips RC5 and Microsoft CIR Protocols, and PME Wake-up Option; New Capability to Capture Carrier Frequency for Learn Mode
 - 4-Channel IR Emitter Transmit Capability (BIRCC)
 - Multiple Base I/O Address Options, 15 IRQ Options and 3 DMA Options
- Multi-Mode Parallel Port with ChiProtect[™]
 - Standard Mode IBM PC/XT[®], PC/AT[®], and PS/2[™] Compatible Bidirectional Parallel Port
 - Enhanced Parallel Port (EPP) Compatible - EPP 1.7 and EPP 1.9 (IEEE 1284 Compliant)
 - IEEE 1284 Compliant Enhanced Capabilities Port (ECP)
 - ChiProtect Circuitry for Protection Against Damage Due to Printer Power-On
 - 192 Base I/O Address, 15 IRQ and 3 DMA Options
- LPC Bus Host Interface
 - Multiplexed Command, Address and Data Bus
 - 8-Bit I/O Transfers
 - 8-Bit DMA Transfers
 - 16-Bit Address Qualification
 - Serial IRQ Interface Compatible with Serialized IRQ Support for PCI Systems
 - PCI CLKRUN# Support
 - Power Management Event (IO_PME#) Interface Pin



ORDER NUMBER: SIO1049-JV FOR 64 PIN, STQFP ROHS COMPLIANT PACKAGE



80 ARKAY DRIVE, HAUPPAUGE, NY 11788 (631) 435-6000, FAX (631) 273-3123

Copyright © 2007 SMSC or its subsidiaries. All rights reserved.

Circuit diagrams and other information relating to SMSC products are included as a means of illustrating typical applications. Consequently, complete information sufficient for construction purposes is not necessarily given. Although the information has been checked and is believed to be accurate, no responsibility is assumed for inaccuracies. SMSC reserves the right to make changes to specifications and product descriptions at any time without notice. Contact your local SMSC sales office to obtain the latest specifications before placing your product order. The provision of this information does not convey to the purchaser of the described semiconductor devices any licenses under any patent rights or other intellectual property rights of SMSC or others. All sales are expressly conditional on your agreement to the terms and conditions of the most recently dated version of SMSC's standard Terms of Sale Agreement dated before the date of your order (the "Terms of Sale Agreement"). The product may contain design defects or errors known as anomalies which may cause the product's functions to deviate from published specifications. Anomaly sheets are available upon request. SMSC products are not designed, intended, authorized or warranted for use in any life support or other application where product failure could cause or contribute to personal injury or severe property damage. Any and all such uses without prior written approval of an Officer of SMSC and further testing and/or modification will be fully at the risk of the customer. Copies of this document or other SMSC literature, as well as the Terms of Sale Agreement, may be obtained by visiting SMSC's website at <http://www.smsc.com>. SMSC is a registered trademark of Standard Microsystems Corporation ("SMSC"). Product names and company names are the trademarks of their respective holders.

SMSC DISCLAIMS AND EXCLUDES ANY AND ALL WARRANTIES, INCLUDING WITHOUT LIMITATION ANY AND ALL IMPLIED WARRANTIES OF MERCHANTABILITY, FITNESS FOR A PARTICULAR PURPOSE, TITLE, AND AGAINST INFRINGEMENT AND THE LIKE, AND ANY AND ALL WARRANTIES ARISING FROM ANY COURSE OF DEALING OR USAGE OF TRADE. IN NO EVENT SHALL SMSC BE LIABLE FOR ANY DIRECT, INCIDENTAL, INDIRECT, SPECIAL, PUNITIVE, OR CONSEQUENTIAL DAMAGES; OR FOR LOST DATA, PROFITS, SAVINGS OR REVENUES OF ANY KIND; REGARDLESS OF THE FORM OF ACTION, WHETHER BASED ON CONTRACT; TORT; NEGLIGENCE OF SMSC OR OTHERS; STRICT LIABILITY; BREACH OF WARRANTY; OR OTHERWISE; WHETHER OR NOT ANY REMEDY OF BUYER IS HELD TO HAVE FAILED OF ITS ESSENTIAL PURPOSE, AND WHETHER OR NOT SMSC HAS BEEN ADVISED OF THE POSSIBILITY OF SUCH DAMAGES.

General Description

SMSC's SIO1049 is the industry's first Consumer Infrared (CIR) transceiver solution and Super I/O Controller designed specifically to support the latest Microsoft® Vista™ operating system features available in Premier and Ultimate Home versions, with native Microsoft drivers. Integrating the CIR functions in the SIO1049 on the motherboard eliminates the need for an external USB dongle, offering a greater than 50% cost savings, while adding features: especially ACPI 2.0 compliant CIR integration.

The CIR port is fully backward compatible and supports NEC, Philips RC5 and Microsoft CIR protocols in hardware for waking from any low power state (S3, S4 and S5) or seamlessly placing the system into a low power state. The SIO1049 also supports all other CIR protocols in software for normal data transfer via a wide-band receiver block, known as "Learn Mode". A third block is provided in order to be able to transmit learned IR control codes on up to four IR emitter ports, for control of set-top boxes and/or other media equipment.

There is an additional dedicated Infrared networking interface, which complies with IrDA v1.2 (FIR, MIR and SIR), HPSIR, and ASKIR formats (used by Sharp and other PDAs).

The SIO1049 also:

- Incorporates a 16C550A compatible UART and one Multi-Mode parallel port with SMSC's ChiProtect(tm) circuitry. The parallel port is compatible with IBM PC/AT architectures, as well as IEEE 1284 EPP and ECP. The parallel port ChiProtect circuitry prevents damage caused by an attached powered printer when the SIO1049 is not powered. The SIO1049 also includes Software Configurable Logic (SCL) for ease of use. SCL allows programmable system configuration of key functions such as the parallel port and UART.
- Does not require any external filter components, is easy to use and offers low system cost and reduced board area benefits with its small 7x7 mm STQFP package. It is optimized for complete system integration on a desktop or notebook motherboard.
- Offers a full 16-bit internally decoded address bus, a Serial IRQ interface with PCI CLKRUN# support, relocatable configuration ports, and three DMA channel options.
- Supports the ISA Plug-and-Play Standard register set (Version 1.0a). The I/O Base Address, DMA Channel, and Hardware IRQ of each device in the SIO1049 may be reprogrammed through the internal configuration registers. There are multiple I/O address location options, a Serialized IRQ interface and three DMA channels.
- Communicates with x86-based chipsets through the LPC interface and includes 14 dedicated GPIO pins.

Block Diagram

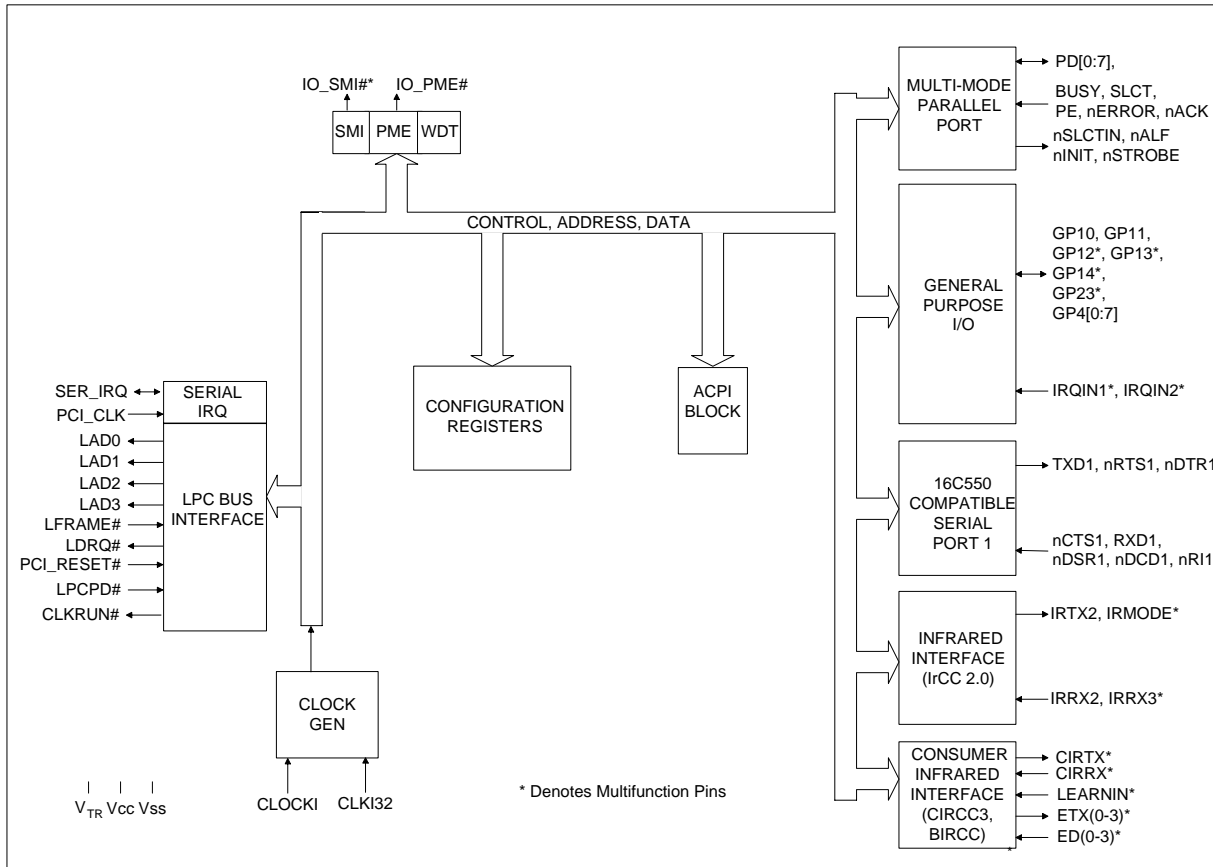

Figure 1 SIO1049 Block Diagram

Pin Configuration

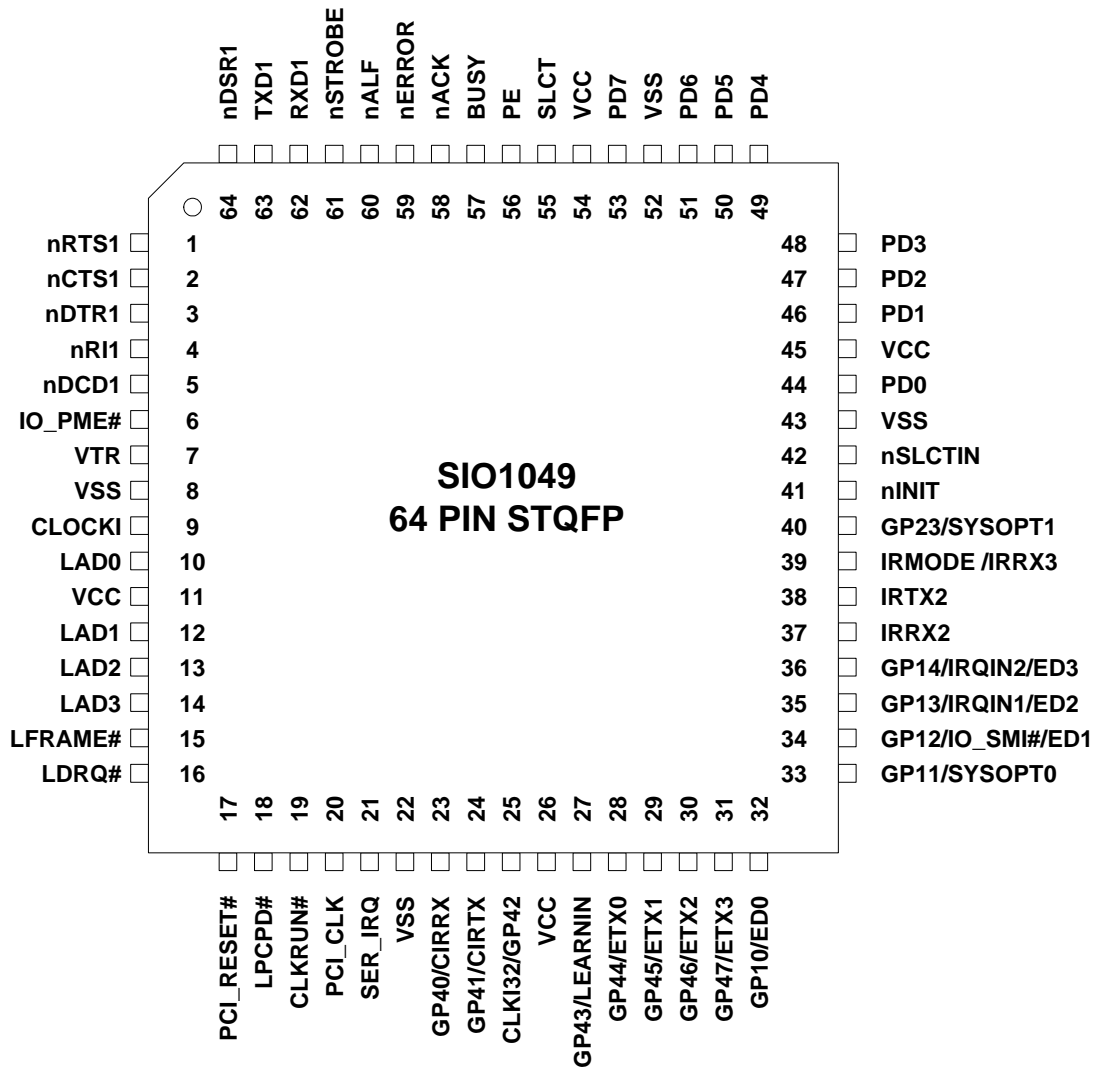

Figure 2 SIO1049 Pin Diagram

Package Outline

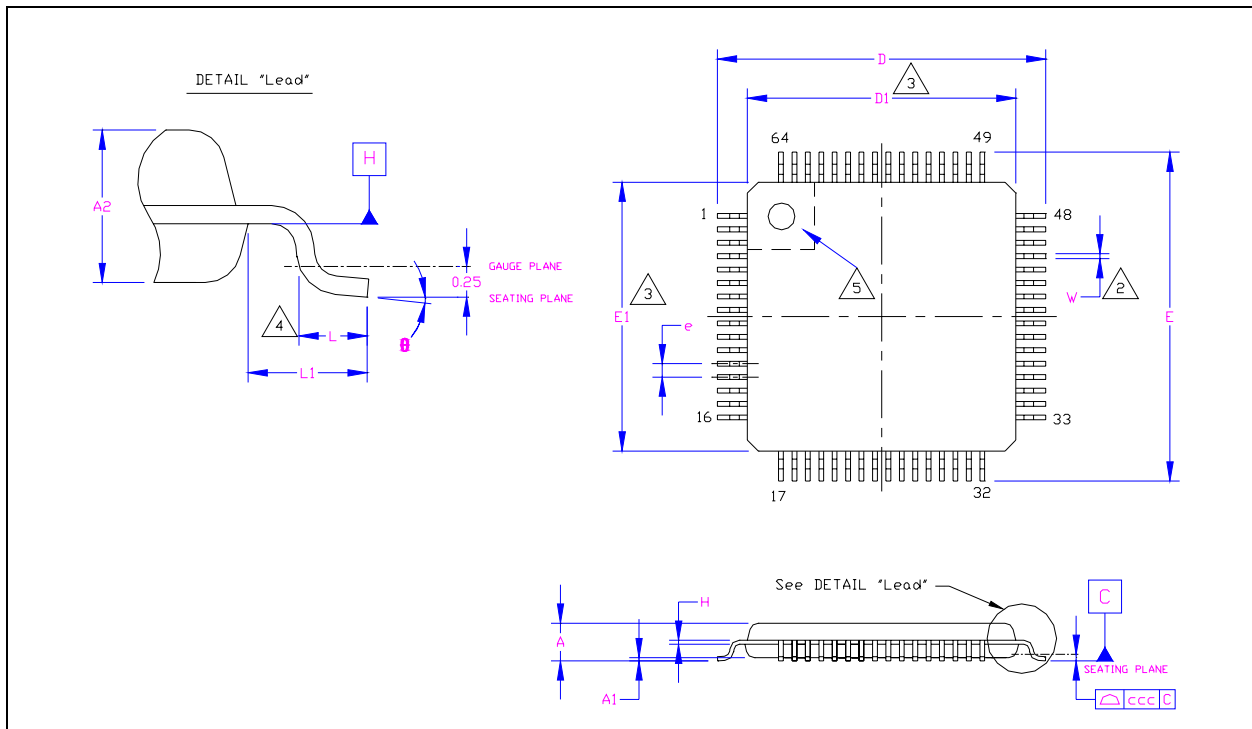

Figure 3 64 Pin STQFP Package Outline, 7X7X1.4 Body, 2 MM Footprint

Table 1 64 Pin STQFP Package Parameters

	MIN	NOMINAL	MAX	REMARKS
A	~	~	1.60	Overall Package Height
A1	0.05	~	0.15	Standoff
A2	1.35	1.40	1.45	Body Thickness
D	8.80	9.00	9.20	X Span
D1	6.80	7.00	7.20	X body Size
E	8.80	9.00	9.20	Y Span
E1	6.80	7.00	7.20	Y body Size
H	0.09	~	0.20	Lead Frame Thickness
L	0.45	0.60	0.75	Lead Foot Length
L1	~	1.00 REF.	~	Lead Length
e	0.40 Basic			Lead Pitch
	0°	~	7°	Lead Foot Angle
W	0.13	0.18	0.23	Lead Width
ccc	~	~	0.08	Coplanarity

Notes:

- Controlling Unit: millimeter.
- Tolerance on the true position of the leads is ± 0.035 mm maximum.
- Package body dimensions D1 and E1 do not include the mold protrusion. Maximum mold protrusion is 0.25 mm per side. D1 and E1 dimensions determined at datum plane H.
- Dimension for foot length L measured at the gauge plane 0.25 mm above the seating plane.
- Details of pin 1 identifier are optional but must be located within the zone indicated.