

Low frequency transistor

2SA2018 / 2SA2030

The transistor of 500mA class which went only into 2125 size conventionally was attained in 1608 sizes or 1208 sizes.

●Applications

For switching, for muting.

●Features

- 1) A collector current is large.
- 2) Collector saturation voltage is low.

$$V_{CE(sat)} \leq 250\text{mV}$$

$$\text{At } I_C = 200\text{mA} / I_B = 10\text{mA}$$

●Absolute maximum ratings (Ta=25°C)

Parameter	Symbol	Limits	Unit
Collector-base voltage	V_{CB0}	15	V
Collector-emitter voltage	V_{CE0}	12	V
Collector current	I_C	500	mA
	I_{CP}	1	A *
Collector power dissipation	P_C	150	mW
Junction temperature	T_j	150	°C
Storage temperature	T_{stg}	-55~+150	°C

*Single pulse, $P_w=1\text{ms}$

●External dimensions (Units : mm)

2SA2018		ROHM : EMT3 EIAJ : SC-75A JEDEC : SOT-416	(1) Emitter (2) Base (3) Collector
2SA2030		ROHM : VMT3	(1) Base (2) Emitter (3) Collector

●Electrical characteristics (Ta=25°C)

Parameter	Symbol	Min.	Typ.	Max.	Unit	Conditions
Collector-base breakdown voltage	BV_{CB0}	15	-	-	V	$I_C=10\mu\text{A}$
Collector-emitter breakdown voltage	BV_{CE0}	12	-	-	V	$I_C=1\text{mA}$
Emitter-base breakdown voltage	BV_{EB0}	6	-	-	V	$I_E=10\mu\text{A}$
Collector cutoff current	I_{CBO}	-	-	100	nA	$V_{CB}=15\text{V}$
DC current transfer ratio	h_{FE}	270	-	680	-	$V_{CE}=2\text{V} / I_C=10\text{mA}$
Collector-emitter saturation voltage	$V_{CE(sat)}$	-	100	250	mV	$I_C=200\text{mA} / I_B=10\text{mA}$
Transition frequency	f_T	-	260	-	MHz	$V_{CE}=2\text{V}, I_E=10\text{mA}, f_T=100\text{MHz}$
Output capacitance	C_{ob}	-	6.5	-	pF	$V_{CB}=10\text{V}, I_E=0\text{A}, f=1\text{MHz}$

●Packaging specifications and h_{FE}

Type	h_{FE}	Package name	Taping	
		Code	TL	T2L
		Basic ordering unit (pieces)	3000	8000
2SA2018			○	-
2SA2030			-	○

Transistors

● Electrical characteristic curves

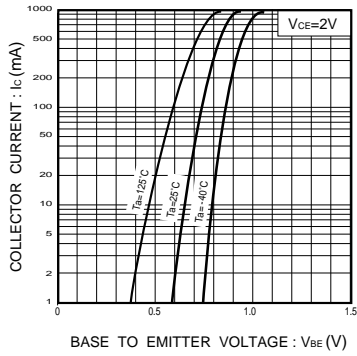

Fig.1 Grounded emitter propagation characteristics

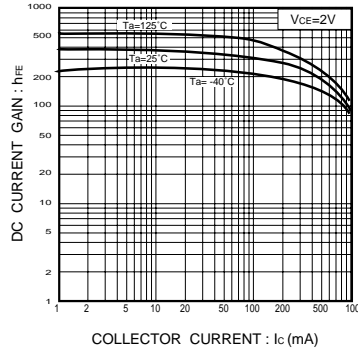

Fig.2 DC current gain vs. collector current

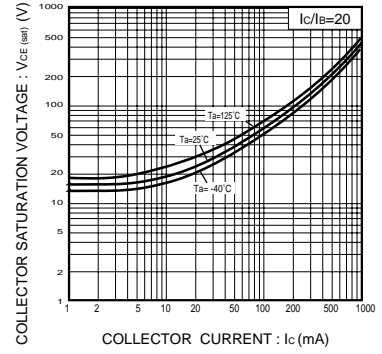

Fig.3 Collector-emitter saturation voltage vs. collector current (I)

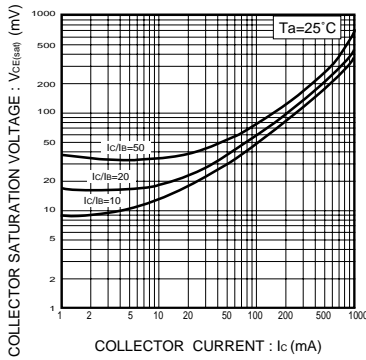

Fig.4 Collector-emitter saturation voltage vs. collector current

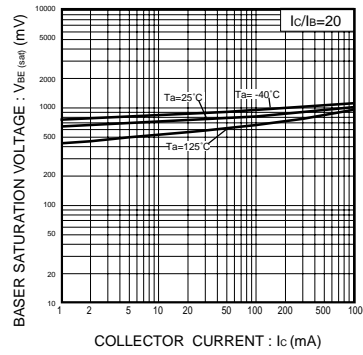

Fig.5 Base-emitter saturation voltage vs. collector current

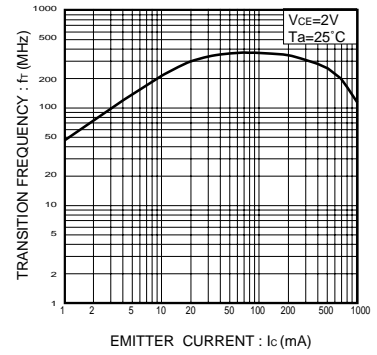

Fig.6 Gain bandwidth product vs. emitter current

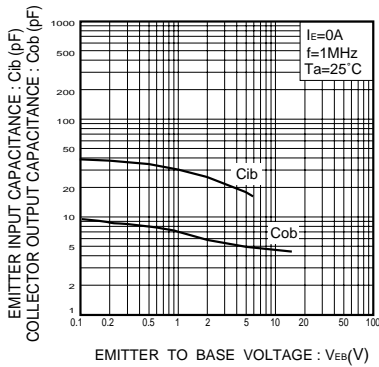

Fig.7 Collector output capacitance vs. collector-base voltage
Emitter input capacitance vs. emitter-base voltage