

General Description:

The Durel[®] D356A is part of a family of highly integrated EL drivers based on Durel's patented three-port (3P) topology, which offers built-in EMI shielding. This high efficiency device is well suited for backlighting most timepieces and liquid crystal displays for portable electronic applications.

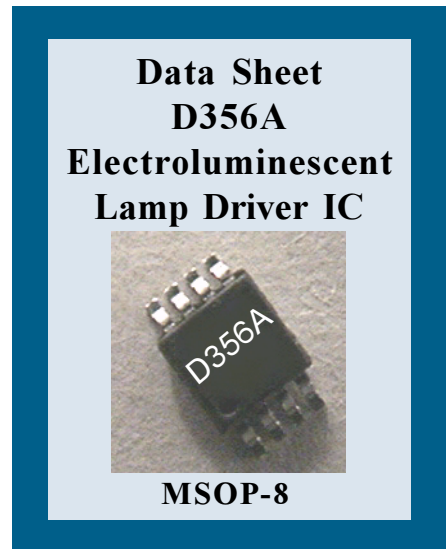

Features

- High Efficiency
- Low Voltage Operation
- Small System Footprint
- Capacitor or External Clock LF Control

Applications

- Watches
- Data Organizers/PDAs
- Pagers
- LCD and Keypad Backlighting

Lamp Driver Specifications:

(Using Standard Test Circuit at Ta=25 °C unless otherwise specified.)

Parameter	Symbol	Minimum	Typical	Maximum	Unit	Conditions
Standby Current			10	100	nA	E = GND
Supply Current	I		23	30	mA	E = 3.0V
Enable Current			50	75	uA	E = 3.0V
Output Voltage	Vout	110	135	220	Vpp	
Lamp Frequency	LF	230	310	390	Hz	CLF=5.0 nF
Inductor Frequency	HF		23		kHz	

Standard Test Circuit

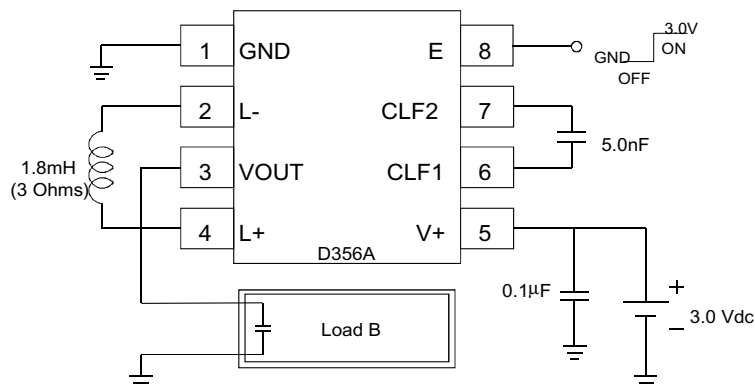

Load B*

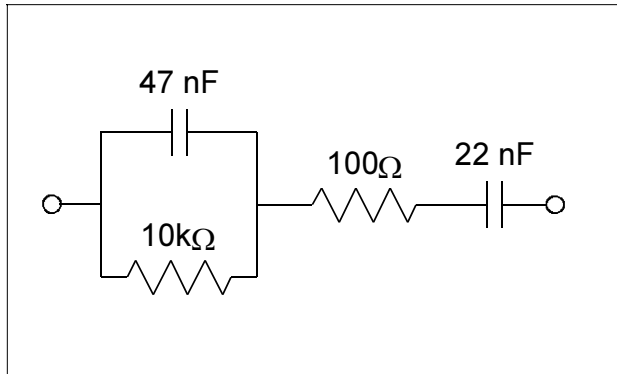

Typical Output Waveform

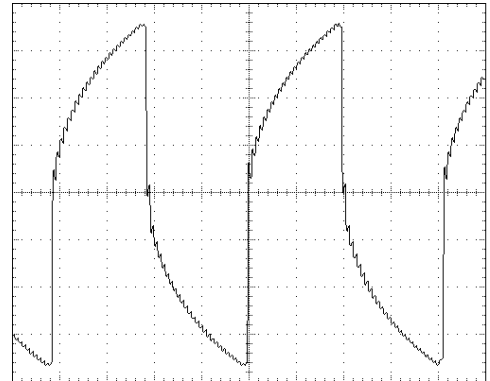

* Load B approximates a 5in² EL lamp.

Absolute Maximum Ratings:

Parameter	Symbol	Minimum	Maximum	Unit	Comments
Supply voltage					
Operating Range	V+	1.0	7.0	V	E = V+
Withstand Range		-0.5	10.0		E = GND
Enable Voltage	E	-0.5	(V+) +0.5	V	
Output Voltage	V _{OUT}		220	V _{pp}	Peak-to-peak voltage
CLF Voltage	V _{CLF}	0	(V+) +0.3	V	External clock input
Operating Temperature	T _a	-40	85	°C	
Storage Temperature	T _s	-65	150	°C	

Note: The above are stress ratings only. Functional operation of the device at these ratings or any other above those indicated in the specifications is not implied. Exposure to absolute maximum rating conditions for extended periods of time may affect reliability.

Physical Data:

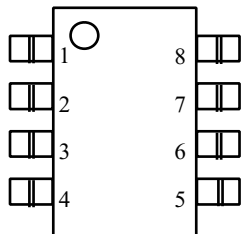

PIN #	NAME	FUNCTION
1	GND	System ground connection
2	L-	Negative input to inductor
3	VOUT	High voltage AC output to lamp
4	L+	Positive input to inductor
5	V+	DC power supply input
6	CLF1	Lamp frequency capacitor/clock input
7	CLF2	Lamp frequency capacitor/clock input
8	E	System enable

Note: Please consult factory for bare die dimensions and bond pad locations.

Typical Performance Characteristics Using Standard Test Circuit

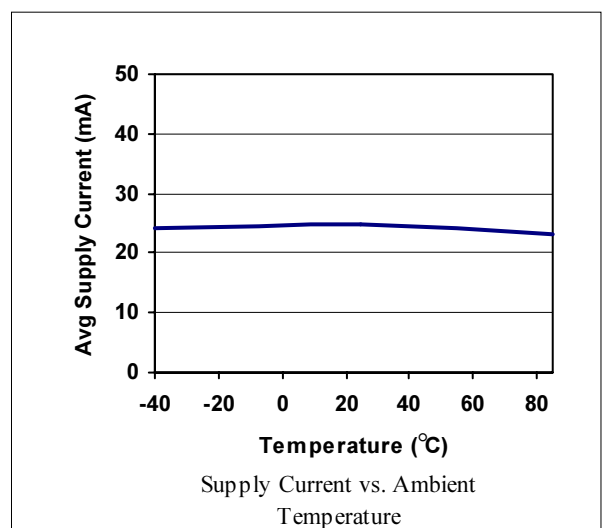
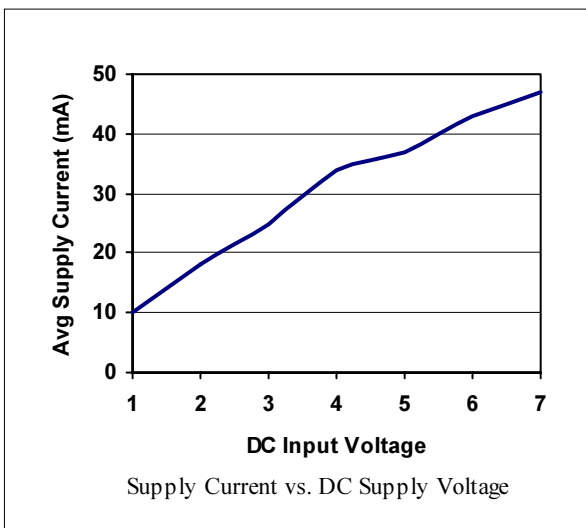
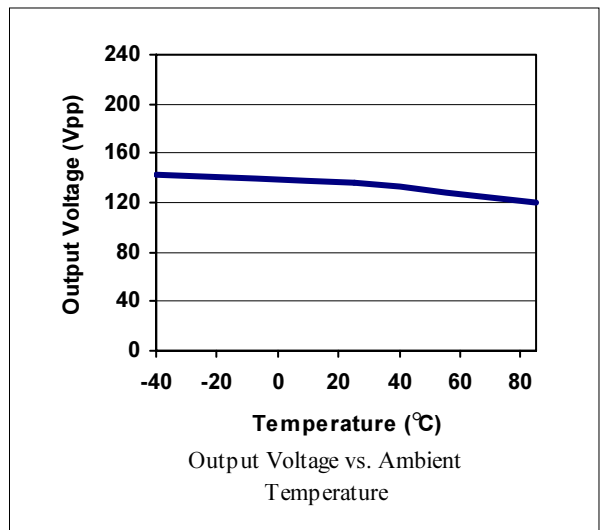
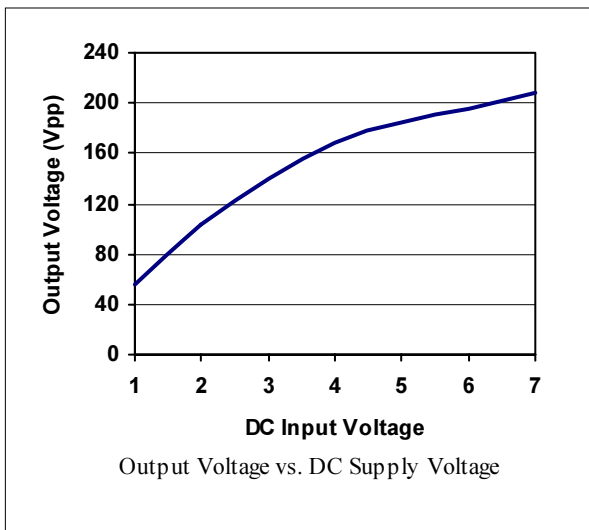
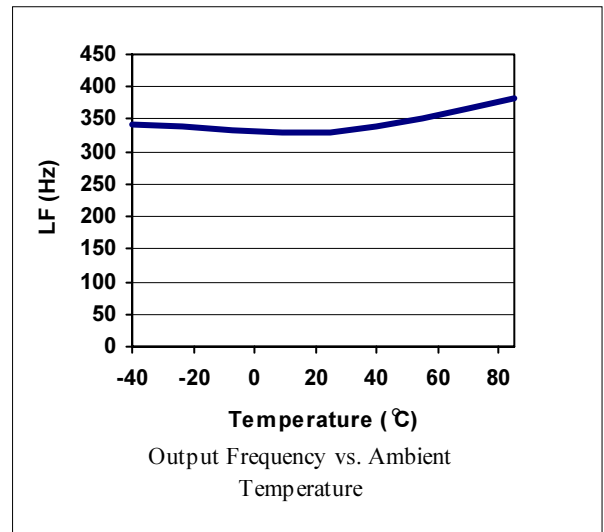
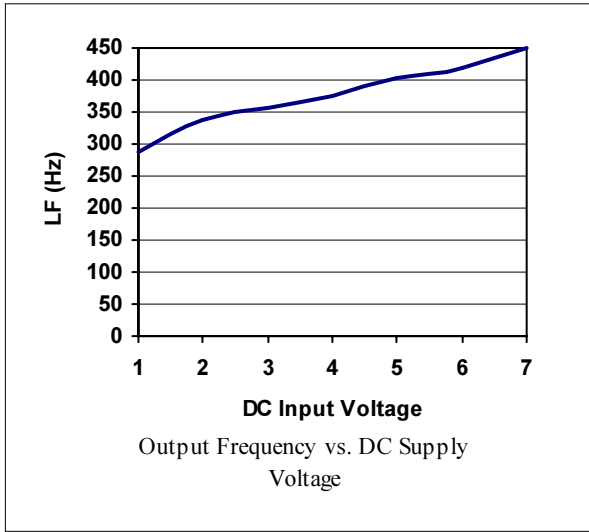

Block Diagram of the Driver Circuitry

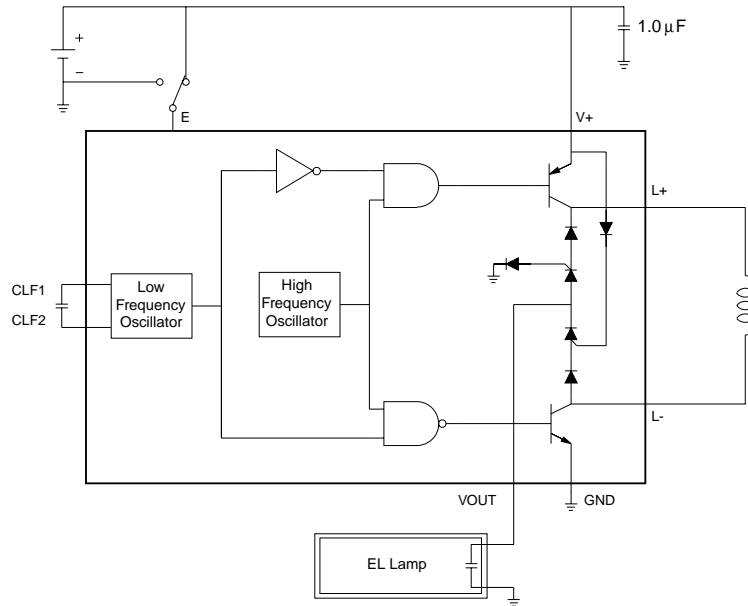

Theory of Operation

Electroluminescent (EL) lamps are essentially capacitors with one transparent electrode and a special phosphor material in the dielectric. When a strong AC voltage is applied across the EL lamp electrodes, the phosphor glows. The required AC voltage is typically not present in most systems and must be generated from a low voltage DC source. Thus, Durel developed its patented Three-Port (3P) switch-mode inverter circuit to convert the available DC supply to an optimal drive signal for high brightness and low-noise EL lamp applications. The Durel 3P topology offers the simplicity of a single DC input, single AC output, and a shared common ground that provides an integrated EMI shielding.

The D356A drives the EL lamp by repeatedly pumping charge through an external inductor with current from a DC source and discharging into the capacitance of the EL lamp load. With each high frequency (HF) cycle the voltage on the lamp is increased. At a period specified by the lamp frequency (LF) oscillator, the voltage on the lamp is discharged to ground and the polarity of the inductive charging is reversed. By this means, an alternating positive and negative voltage is developed at the single output lead of the device to one of the electrodes of the EL lamp. The other lamp electrode is commonly connected to a ground plane, which can then be considered as electrical shielding for any underlying circuitry on the application.

The EL driving system is divided into several parts: on-chip logic and control, on-chip high voltage output circuitry, discharge logic circuitry, and off-chip components. The on-chip logic controls the output frequency (LF), as well as the inductor switching frequency (HF), and HF and LF duty cycles. These signals are combined and buffered to regulate the high voltage output circuitry. The output circuitry handles the power through the inductor and delivers the high voltage to the lamp. The selection of off-chip components provides a degree of flexibility to accommodate various lamp sizes, system voltages, and brightness levels. Since a key objective for EL driver systems is to save space and cost, required off-chip components were kept to a minimum.

Durel provides a D356A Designer's Kit, which includes a printed circuit evaluation board intended to aid you in developing an EL lamp driver configuration using the D356A that meets your requirements. A section on designing with the D356A is included in this datasheet to serve as a guide to help you select the appropriate external components to complete your D356A EL driver system.

Typical D356A configurations for driving EL lamps in various applications are shown on the following page. The expected system outputs, such as lamp luminance, lamp output frequency and voltage and average supply current draw, for the various sample configurations are also shown with each respective figure.

Typical D356A EL Driver Configurations

1.5V Analog Watch

Typical Output

Luminance = 2.6 fL (9 cd/m²)
 Lamp Frequency = 220 Hz
 Supply Current = 11 mA
 V_{out} = 160 V_{pp}
 Load = 1 in² Durel®3 Green EL

2.2 mH
 Sumida
 CLS62-222KC

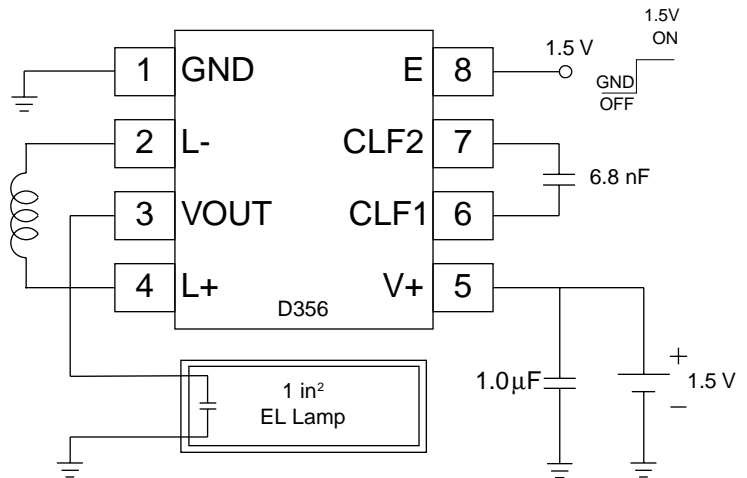

3.0V Handset LCD or Digital Watch

Typical Output

Luminance = 7.5 fL (26 cd/m²)
 Lamp Frequency = 475 Hz
 Supply Current = 13 mA
 V_{out} = 200 V_{pp}
 Load = 1 in² Durel®3 Green EL

4.7 mH
 Coilcraft
 DT1608C-475

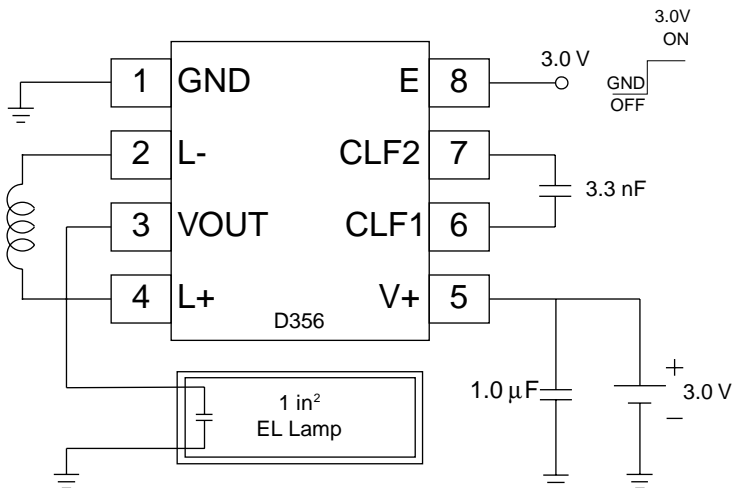

5.0V PDA

Typical Output

Luminance = 6 fL (21 cd/m²)
 Lamp Frequency = 360 Hz
 Supply Current = 18 mA
 V_{out} = 190 V_{pp}
 Load = 4 in² Durel® Green EL

5.0 mH
 Hitachi Metals
 MD735L502A

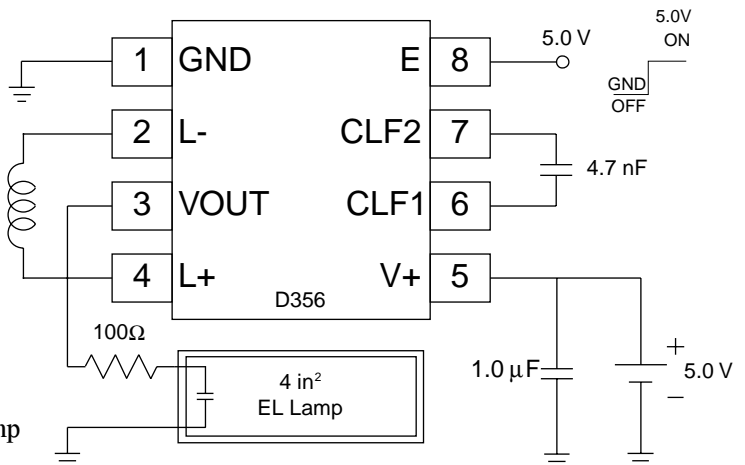

*A 100Ω resistor in series with the V_{OUT} to EL lamp may be necessary to reduce electrical noise.

Designing With D356A

I. Lamp Frequency Capacitor (CLF) Selection

Selecting the appropriate value of capacitor for the low frequency oscillator (CLF) will set the output frequency of the D356A inverter. Figure 1 graphically represents the inversely proportional relationship between the CLF capacitor value and the oscillator frequency. In this example at $V^+ = 3.0V$, $LF = 1600 \text{ nF}\cdot\text{Hz}/\text{CLF}$.

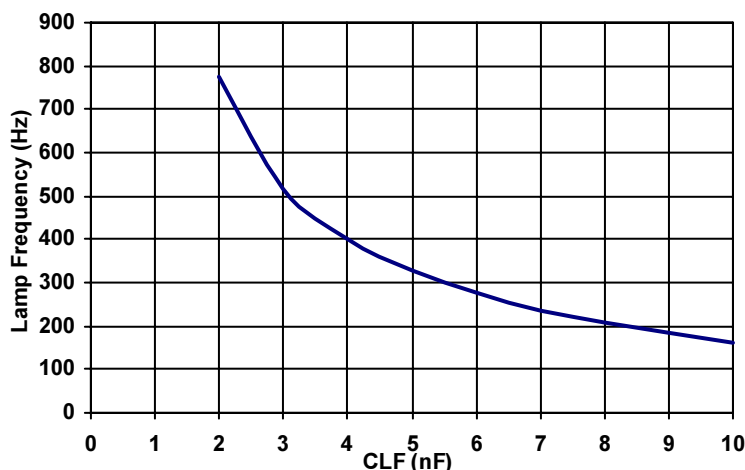

Figure 1: Typical Lamp Frequency vs. CLF Capacitor

Alternatively, the lamp frequency may also be controlled with an external clock signal with a 50% duty cycle. The output lamp frequency will be the same frequency as the input clock signal. For example, if a 250Hz input clock signal is used, the resulting lamp frequency will be 250Hz. The clock signal input voltage should not exceed V^+ .

The selection of the CLF value can also affect the brightness of the EL lamp because of its control of the lamp frequency (LF). Although input voltage and lamp size can change EL lamp frequency as well, LF mainly depends on the CLF value selected or the frequency of the input clock signal to CLF. The luminance of various sizes of Durel 3 Blue-green EL lamp driven by a D356A at $V^+ = 3.0V$ using the same inductor value is shown in Figure 2 with respect to lamp frequency.

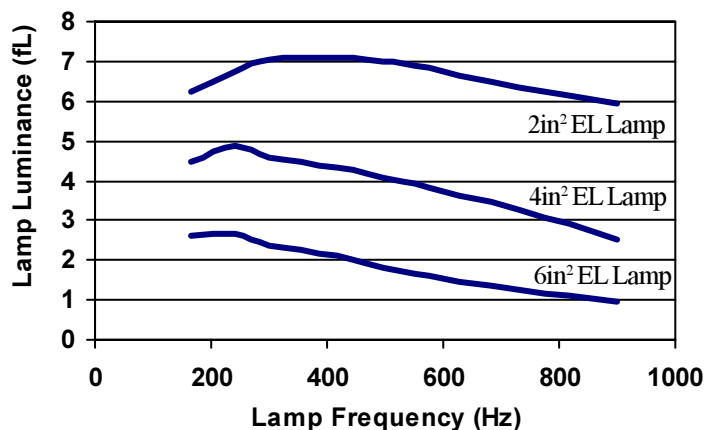

Figure 2: Typical Lamp Luminance vs. Lamp Frequency

II. Inductor (L) Selection

The external inductor (L) selection for a D356A circuit greatly affects the output capability and current draw of the driver. A careful designer will balance current draw considerations with output performance in the choice of an ideal inductor for a particular application. Figures 3, 4, and 5 show typical brightness and current draw of a D356A circuit with different inductor values, lamp sizes, and supply voltages. Please note that the DC resistance (DCR) of inductors with the same nominal inductance value may vary with manufacturer and inductor type. Thus, inductors made by a different manufacturer may yield different outputs, but the trend of the different curves should be similar. Lamp luminance is also a function of lamp size. In each example, a larger lamp will have less luminance with approximately the same current draw.

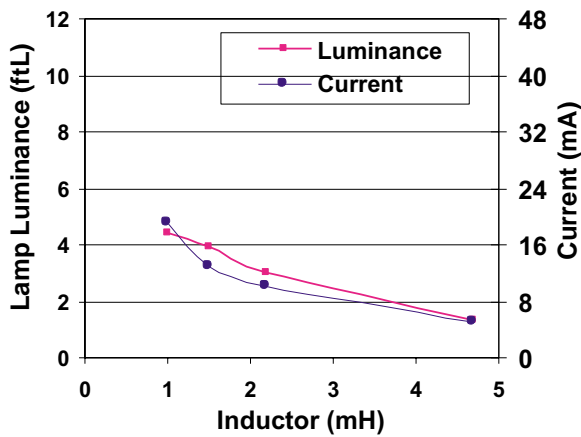

Figure 3: V+=1.5V, 1 in² EL Lamp

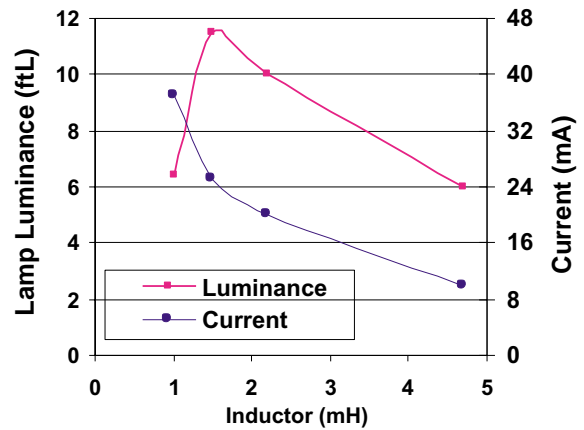

Figure 4: V+=3.0V, 1 in² EL Lamp

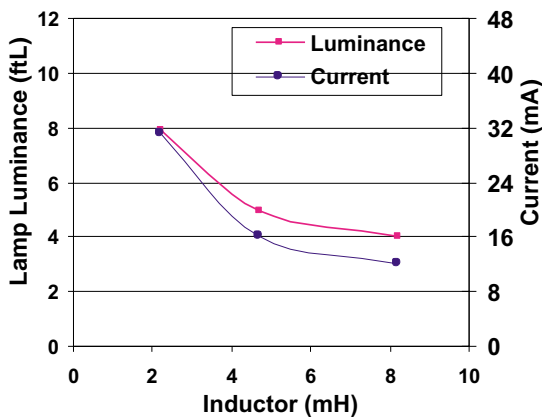
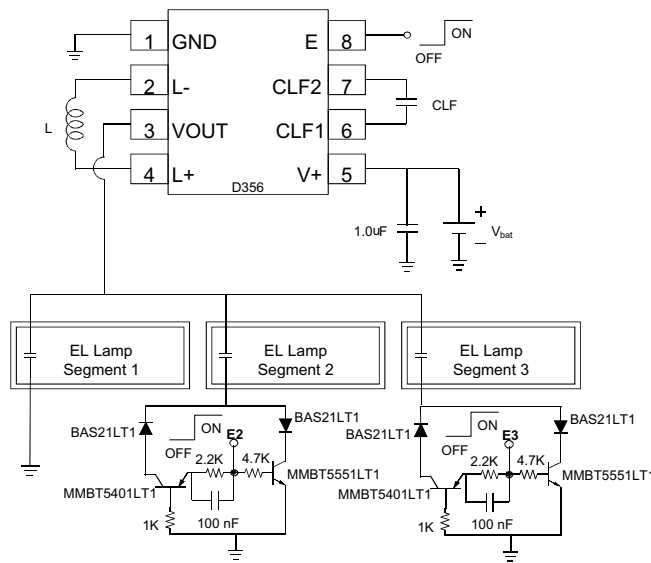

Figure 5: V+=5.0V, 4 in² EL Lamp

D356A Design Ideas

I. Driving Multi-segment Lamps

The D356A may be used to drive two or more EL lamps or EL lamp areas independently. An external switching circuit can be used to turn each lamp segment on or off. A high signal at the E input for the corresponding EL lamp will power the segment when the IC is enabled. In this example, Segment 1 is always on when the Durel D356A is enabled. Otherwise, always make sure that at least one segment is switched on when the driver IC is activated.



II. Two-Level Dimming

Toggle switching between two different EL lamp brightness levels may be achieved with the following circuit. When DIM is low, the external pnp transistor is saturated and the EL lamp runs at full brightness. When DIM is high, the external pnp turns off and the 47Ω resistor reduces the voltage at (V+) and dims the EL lamp.

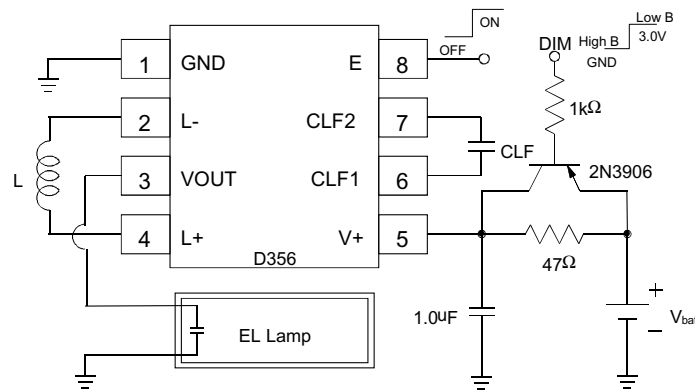

III. Lamp Frequency Control with an External Clock Signal

An external clock signal may be used to control the EL lamp frequency (LF). This technique allows the designer flexibility to synchronize the EL driver IC with other elements in the application. The output lamp frequency will be the same frequency as the input clock signal. For example, if a 250Hz input clock signal is used, the resulting lamp frequency will be 250Hz. The clock signal voltage should not exceed V_{+} .

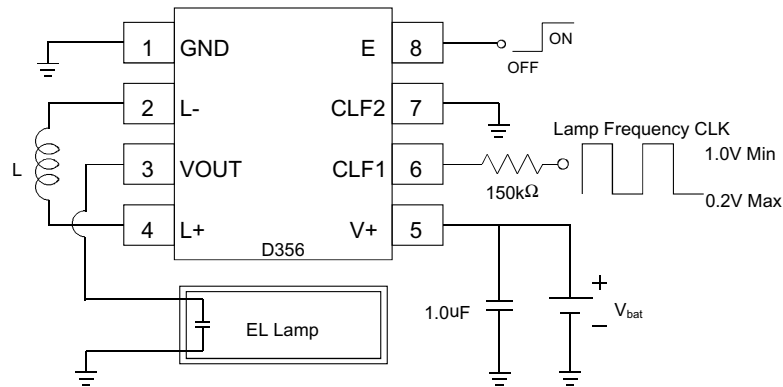

IV. EL Lamp Brightness Regulation

Regulating the DC supply input voltage to the D356A will result in a constant brightness level from the EL lamp, regardless of battery voltage. In this example, a Micrel voltage regulator is used.

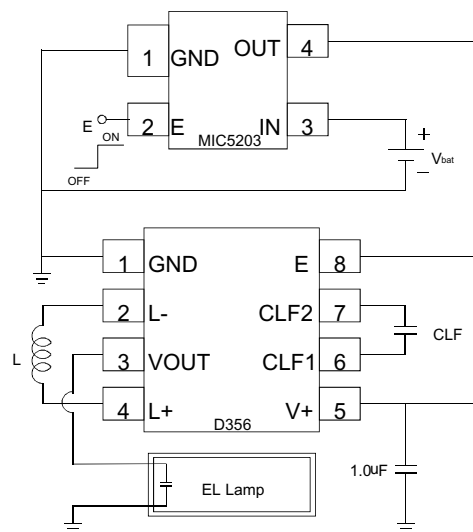

V. High EL Brightness Through Supply Voltage Doubling (Option 1)

Maximum brightness from a D356A is achieved at relatively high supply voltages (>3.0V). An external voltage boost circuit may be used to increase the voltage supplied to the D356A. In the following circuit, the National Semiconductor LM2665 is used to double the voltage supplied to the D356A. This can produce about twice the brightness of the D356A alone.

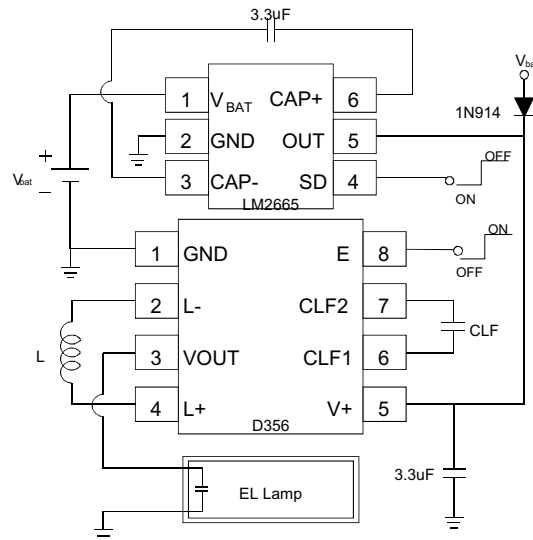

VI. High EL Brightness Through Supply Voltage Doubling (Option 2)

In many cases, a resistor may replace the diode in the previous circuit. The diode is used by the LM2665 during startup (see LM2665 datasheet). The circuit below ensures that the LM2665 starts properly before the D356A is turned on.

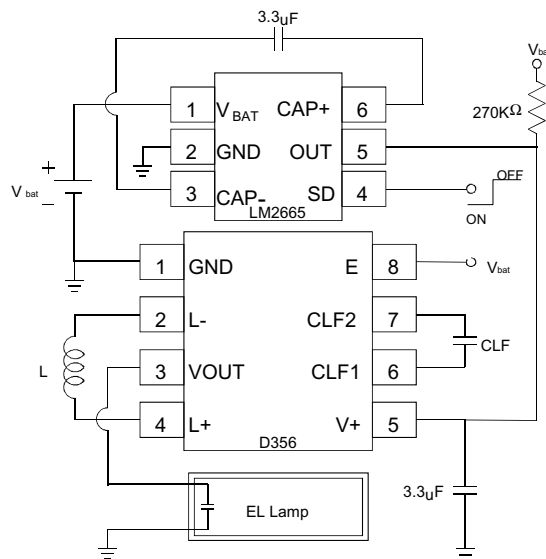

VII. High EL Brightness With Parallel D356A (Option 1)

Two or more D356A EL drivers may be operated in parallel to increase the brightness of the EL lamp by 50-100%. In this circuit, an external clock signal with 50% duty cycle is needed to synchronously drive both D356A ICs. The clock signal voltage should not exceed $V+$.

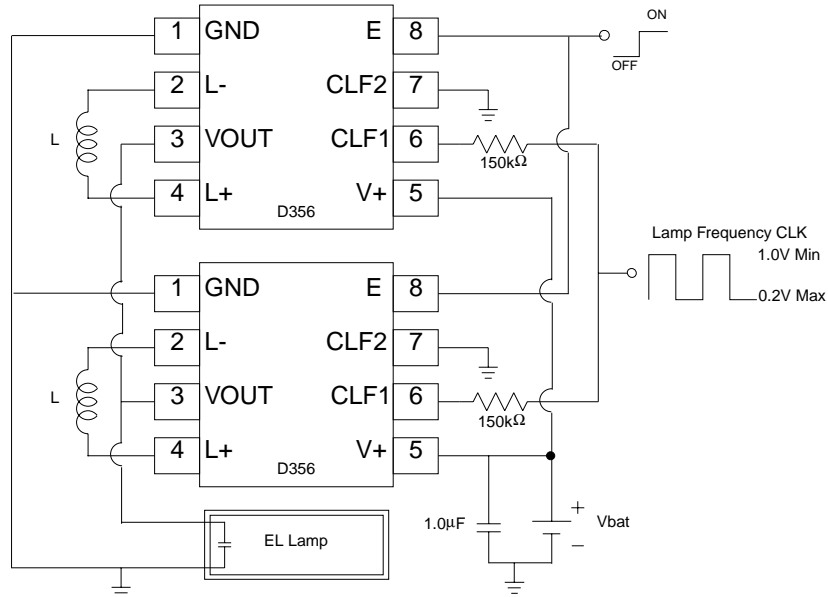

VIII. High EL Brightness With Parallel D356A (Option 2)

Two or more D356A EL drivers may be operated in parallel to increase the brightness of the EL lamp by 50-100%. In this circuit, two D356A ICs are operating synchronously using their internal oscillators. The lamp frequency is controlled by a shared CLF capacitor.

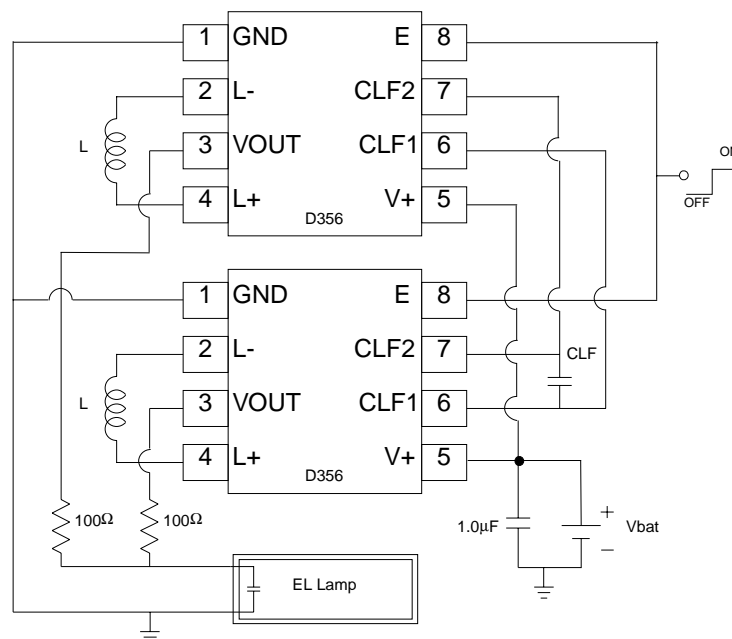

Ordering Information

The D356A IC is available as bare die in probed wafer form or in die tray, and in standard MSOP-8 plastic package per tube or per tape and reel. A Durel D356A Designer's Kit (1DDD356AA-K01) provides a vehicle for evaluating and identifying the optimum component values for any particular application using D356A. Durel engineers also provide full support to customers, including specialized circuit optimization and application retrofits.

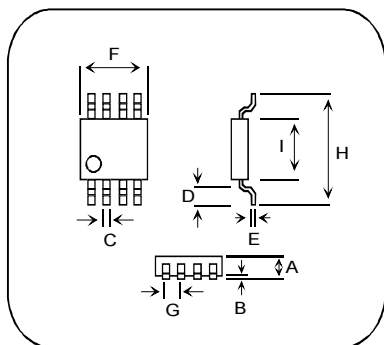

RECOMMENDED PAD LAYOUT

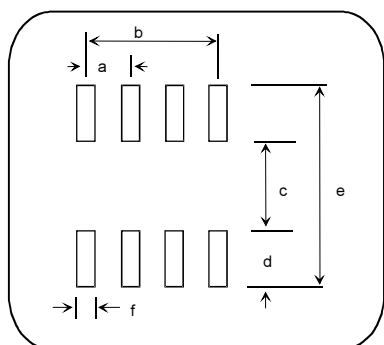

MSOPs in Tape and Reel: 1DDD356AA-M02

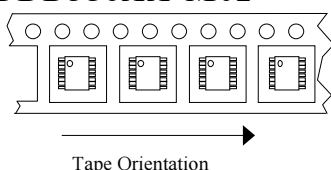

Embossed tape on 360 mm diameter reel per EIA-481-2.
2500 units per reel. Quantity marked on reel label.

Description	MSOP-8					
	Min.		Typical		Max.	
	mm.	in.	mm.	in.	mm.	in.
A	0.94	0.037	1.02	0.040	1.09	0.043
B	0.05	0.002	0.10	0.004	0.15	0.006
C	0.20	0.008	0.33	0.013	0.46	0.018
D	0.41	0.016	0.53	0.021	0.65	0.026
E	0.13	0.005	0.18	0.007	0.23	0.009
F	2.84	0.112	3.00	0.118	3.15	0.124
G	0.43	0.017	0.65	0.026	0.83	0.033
H	4.70	0.185	4.90	0.193	5.11	0.201
I	2.84	0.112	3.00	0.118	3.25	0.128

MSOPs are marked with part number (356A) and 3-digit wafer lot code. Bottom of marking is on the Pin 1 side.

	MSOP-8 PAD LAYOUT					
	Min.		Typical		Max.	
	mm.	in.	mm.	in.	mm.	in.
a	0.60	0.0236	0.6	0.0256	0.70	0.0276
b	1.90	0.0748	1.9	0.0768	2.00	0.0788
c	3.3	0.130			3.45	0.136
d	0.89	0.035	0.9	0.038	1.05	0.041
e	5.26	0.207			5.41	0.213
f	0.41	0.016	0.4	0.018	0.51	0.020

ISO 9001 Certified

DUREL Corporation

2225 W. Chandler Blvd.

Chandler, AZ 85224-6155

Tel: (480) 917-6000

FAX: (480) 917-6049

Website: <http://www.durel.com>

The DUREL name and logo are registered trademarks of DUREL CORPORATION.

This information is not intended to and does not create any warranties, express or implied, including any warranty of merchantability or fitness for a particular purpose. The relative merits of materials for a specific application should be determined by your evaluation.

This driver is covered by the following U.S. patents: #5,313,141, #5,347,198; #6,043,610. Corresponding foreign patents are issued and pending.