

XC866

8-Bit Single Chip Microcontroller

8bit

Microcontrollers



Never stop thinking.

Edition 2005-01

**Published by Infineon Technologies AG,
St.-Martin-Strasse 53,
81669 München, Germany**

**© Infineon Technologies AG 2005.
All Rights Reserved.**

Attention please!

The information herein is given to describe certain components and shall not be considered as a guarantee of characteristics.

Terms of delivery and rights to technical change reserved.

We hereby disclaim any and all warranties, including but not limited to warranties of non-infringement, regarding circuits, descriptions and charts stated herein.

Information

For further information on technology, delivery terms and conditions and prices please contact your nearest Infineon Technologies Office (www.infineon.com).

Warnings

Due to technical requirements components may contain dangerous substances. For information on the types in question please contact your nearest Infineon Technologies Office.

Infineon Technologies Components may only be used in life-support devices or systems with the express written approval of Infineon Technologies, if a failure of such components can reasonably be expected to cause the failure of that life-support device or system, or to affect the safety or effectiveness of that device or system. Life support devices or systems are intended to be implanted in the human body, or to support and/or maintain and sustain and/or protect human life. If they fail, it is reasonable to assume that the health of the user or other persons may be endangered.

XC866

8-Bit Single Chip Microcontroller

Microcontrollers



Never stop thinking.

XC866

Revision History: 2005-01

V 0.2

Previous Version:

We Listen to Your Comments

Any information within this document that you feel is wrong, unclear or missing at all?
Your feedback will help us to continuously improve the quality of this document.

Please send your proposal (including a reference to this document) to:

mcdocu.comments@infineon.com



Table of Contents		Page
1	Introduction	1-1
1.1	Feature Summary	1-3
1.2	Pin Configuration	1-5
1.3	Pin Definitions and Functions	1-6
1.4	Textual Convention	1-12
1.5	Reserved, Undefined and Unimplemented Terminology	1-13
1.6	Acronyms	1-14
2	Processor Architecture	2-1
2.1	Functional Description	2-2
2.2	CPU Register Description	2-4
2.2.1	Stack Pointer (SP)	2-4
2.2.2	Data Pointer (DPTR)	2-4
2.2.3	Accumulator (ACC)	2-4
2.2.4	B Register	2-4
2.2.5	Program Status Word	2-5
2.2.6	Extended Operation Register (EO)	2-6
2.2.7	Power Control Register (PCON)	2-7
2.3	Instruction Timing	2-8
3	Memory Organization	3-1
3.1	Program Memory	3-3
3.2	Data Memory	3-3
3.2.1	Internal Data Memory	3-3
3.2.2	External Data Memory	3-3
3.3	Special Function Registers	3-4
3.3.1	Address Extension by Mapping	3-4
3.3.2	Address Extension by Paging	3-6
3.3.3	Bit-Addressing	3-9
3.3.4	System Control Registers	3-10
3.3.4.1	Bit Protection Scheme	3-12
3.3.5	XC866 Register Overview	3-13
3.3.5.1	CPU Registers	3-13
3.3.5.2	System Control Registers	3-14
3.3.5.3	WDT Registers	3-16
3.3.5.4	Port Registers	3-16
3.3.5.5	ADC Registers	3-17
3.3.5.6	Timer 2 Registers	3-20
3.3.5.7	CCU6 Registers	3-20
3.3.5.8	SSC Registers	3-24
3.3.5.9	OCDS Registers	3-25
3.4	Boot ROM Operating Mode	3-26
3.4.1	User Mode	3-26

Table of Contents		Page
3.4.2	BootStrap Loader Mode	3-27
3.4.3	OCDS Mode	3-27
4	Flash Memory	4-1
4.1	Flash Memory Map	4-2
4.2	Flash Bank Sectorization	4-3
4.3	Wordline Address	4-5
4.4	Operating Modes	4-7
4.5	Error Detection and Correction	4-8
4.6	In-System Programming	4-9
4.7	In-Application Programming	4-10
4.7.1	D-Flash Programming	4-11
4.7.2	D-Flash Erasing	4-13
5	Interrupt System	5-1
5.1	Non-maskable Interrupt	5-1
5.2	Maskable Interrupts	5-1
5.2.1	Internal Interrupts	5-1
5.2.2	External Interrupts	5-2
5.2.3	Extended Interrupts	5-2
5.3	Interrupt Source and Vector	5-8
5.4	Interrupt Register Description	5-9
5.4.1	Interrupt Enable Registers	5-9
5.4.2	Interrupt Request Flags	5-14
5.4.3	Interrupt Priority Registers	5-19
5.4.4	Interrupt Priority	5-21
5.4.5	Interrupt Request Flags	5-22
5.5	Interrupt Handling	5-23
5.6	Interrupt Response Time	5-24
6	Parallel Ports	6-1
6.1	General Port Operation	6-2
6.1.1	General Register Description	6-5
6.1.1.1	Data Register	6-6
6.1.1.2	Direction Register	6-7
6.1.1.3	Open Drain Control Register	6-7
6.1.1.4	Pull-Up/Pull-Down Device Register	6-8
6.1.1.5	Alternate Input Functions	6-10
6.1.1.6	Alternate Output Functions	6-10
6.2	Register Map	6-11
6.3	Port 0	6-14
6.3.1	Functions	6-14
6.3.2	Register Description	6-16

Table of Contents		Page
6.4	Port 1	6-19
6.4.1	Functions	6-19
6.4.2	Register Description	6-21
6.5	Port 2	6-24
6.5.1	Functions	6-24
6.5.2	Register Description	6-26
6.6	Port 3	6-28
6.6.1	Functions	6-28
6.6.2	Register Description	6-31
7	Power Supply, Reset and Clock Management	7-1
7.1	Power Supply System with Embedded Voltage Regulator	7-1
7.2	Reset Control	7-3
7.2.1	Types of Reset	7-3
7.2.1.1	Power-On Reset	7-3
7.2.1.2	Hardware Reset	7-4
7.2.1.3	Watchdog Timer Reset	7-4
7.2.1.4	Power-Down Wake-Up Reset	7-4
7.2.1.5	Brownout Reset	7-5
7.2.2	Module Reset Behavior	7-6
7.2.3	Bootling Scheme	7-6
7.2.4	Register Description	7-7
7.3	Clock System	7-9
7.3.1	Clock Generation Unit	7-9
7.3.1.1	Functional Description	7-10
7.3.2	Clock Source Control	7-11
7.3.3	Clock Management	7-13
7.3.4	Register Description	7-14
8	Power Saving Modes	8-1
8.1	Functional Description	8-2
8.1.1	Idle Mode	8-2
8.1.2	Slow-Down Mode	8-2
8.1.3	Power-down Mode	8-3
8.1.4	Peripheral Clock Management	8-4
8.2	Register Description	8-6
9	Watchdog Timer	9-1
9.1	Functional Description	9-2
9.2	Register Map	9-5
9.3	Register Description	9-5
10	Serial Interfaces	10-1
10.1	UART	10-2

Table of Contents		Page
10.1.1	UART Modes	10-2
10.1.1.1	Mode 1, 8-Bit UART, Variable Baud Rate	10-2
10.1.1.2	Mode 2, 9-Bit UART, Fixed Baud Rate	10-5
10.1.1.3	Mode 3, 9-Bit UART, Variable Baud Rate	10-5
10.1.2	Multiprocessor Communication	10-7
10.1.3	Register Description	10-7
10.1.4	Baud Rate Generation	10-9
10.1.4.1	Baud-rate Generator	10-10
10.1.5	Interfaces of UART	10-13
10.2	LIN	10-14
10.2.1	LIN Protocol	10-14
10.2.2	LIN Header Transmission	10-16
10.2.3	Baud Rate Detection of LIN	10-17
10.3	High-Speed Synchronous Serial Interface	10-19
10.3.1	General Operation	10-20
10.3.1.1	Operating Mode Selection	10-20
10.3.1.2	Full-Duplex Operation	10-21
10.3.1.3	Half-Duplex Operation	10-24
10.3.1.4	Continuous Transfers	10-25
10.3.1.5	Port Control	10-25
10.3.1.6	Baud Rate Generation	10-26
10.3.1.7	Error Detection Mechanisms	10-27
10.3.2	Interrupts	10-30
10.3.3	Register Mapping	10-31
10.3.4	Register Description	10-32
10.3.4.1	Port Input Select Register	10-32
10.3.4.2	Configuration Register	10-33
10.3.4.3	Baud Rate Timer Reload Register	10-37
10.3.4.4	Transmit and Receive Buffer Register	10-38
11	Timers	11-1
11.1	Timer 0 and Timer 1	11-1
11.1.1	Basic Timer Operations	11-1
11.1.2	Timer Modes	11-2
11.1.2.1	Mode 0	11-3
11.1.2.2	Mode 1	11-4
11.1.2.3	Mode 2	11-5
11.1.2.4	Mode 3	11-6
11.1.3	Register Map	11-7
11.1.4	Register Description	11-8
11.2	Timer 2	11-13
11.2.1	Auto-Reload Mode	11-13
11.2.1.1	Up/Down Count Disabled	11-13

Table of Contents		Page
11.2.1.2	Up/Down Count Enabled	11-14
11.2.2	Capture Mode	11-16
11.2.3	Register Map	11-17
11.2.4	Register Description	11-17
12	Capture/Compare Unit 6	12-1
12.1	Functional Description	12-3
12.1.1	Timer T12	12-3
12.1.1.1	Timer Configuration	12-4
12.1.1.2	Counting Rules	12-4
12.1.1.3	Switching Rules	12-4
12.1.1.4	Compare Mode of T12	12-6
12.1.1.5	Duty Cycle of 0% and 100%	12-7
12.1.1.6	Dead-time Generation	12-8
12.1.1.7	Capture Mode	12-9
12.1.1.8	Single-Shot Mode	12-9
12.1.1.9	Hysteresis-Like Control Mode	12-10
12.1.2	Timer T13	12-11
12.1.2.1	Timer Configuration	12-11
12.1.2.2	Compare Mode	12-12
12.1.2.3	Single-Shot Mode	12-12
12.1.2.4	Synchronization of T13 to T12	12-13
12.1.3	Modulation Control	12-13
12.1.4	Trap Handling	12-16
12.1.5	Multi-Channel Mode	12-17
12.1.6	Hall Sensor Mode	12-19
12.1.6.1	Sampling of the Hall Pattern	12-19
12.1.6.2	Brushless-DC Control	12-20
12.1.7	Interrupt Generation	12-23
12.1.8	Port Connection	12-23
12.2	Register Map	12-26
12.3	Register Description	12-29
12.3.1	System Registers	12-31
12.3.1.1	Port Input Selection	12-31
12.3.2	Timer T12 – Related Registers	12-35
12.3.3	Timer T13 – Related Registers	12-41
12.3.4	Capture/Compare Control Registers	12-45
12.3.5	Modulation Control Registers	12-57
12.3.5.1	Global Module Control	12-57
12.3.5.2	Multi-Channel Control	12-65
12.3.6	Interrupt Control Registers	12-77
13	Analog-to-Digital Converter	13-1

Table of Contents		Page
13.1	Structure Overview	13-2
13.2	Clocking Scheme	13-3
13.2.1	Conversion Timing	13-4
13.3	Low Power Mode	13-7
13.4	Functional Description	13-8
13.4.1	Request Source Arbiter	13-9
13.4.2	Conversion Start Modes	13-10
13.4.3	Channel Control	13-10
13.4.4	Sequential Request Source	13-11
13.4.4.1	Overview	13-11
13.4.4.2	Request Source Control	13-12
13.4.5	Parallel Request Source	13-13
13.4.5.1	Overview	13-13
13.4.5.2	Request Source Control	13-13
13.4.5.3	External Trigger	13-14
13.4.5.4	Software Control	13-14
13.4.5.5	Autoscan	13-15
13.4.6	Wait-for-Read Mode	13-15
13.4.7	Result Generation	13-16
13.4.7.1	Overview	13-16
13.4.7.2	Limit Checking	13-17
13.4.7.3	Data Reduction Filter	13-18
13.4.7.4	Result FIFO Functionality	13-19
13.4.7.5	Result Register View	13-19
13.4.8	Interrupts	13-21
13.4.8.1	Event Interrupts	13-22
13.4.8.2	Channel Interrupts	13-23
13.4.9	External Trigger Inputs	13-25
13.5	ADC Module Initialization Sequence	13-26
13.6	Register Map	13-28
13.7	Register Description	13-31
13.7.1	General Function Registers	13-31
13.7.2	Priority and Arbitration Register	13-33
13.7.3	External Trigger Control Register	13-35
13.7.4	Channel Control Registers	13-36
13.7.5	Input Class Register	13-37
13.7.6	Sequential Source Registers	13-38
13.7.7	Parallel Source Registers	13-44
13.7.8	Result Registers	13-48
13.7.9	Interrupt Registers	13-52
14	On-Chip Debug Support	14-1
14.1	Functional Description	14-2

Table of Contents		Page
14.2	Debugging	14-3
14.2.1	Debug Events	14-3
14.2.1.1	Hardware Breakpoints	14-4
14.2.1.2	Software Breakpoints	14-5
14.2.1.3	External Breaks	14-6
14.2.2	Debug Actions	14-6
14.2.2.1	Call the Monitor Program	14-6
14.2.2.2	Activate the MBC pin	14-6
14.3	Register Description	14-7
14.3.1	JTAG ID Register	14-9
15	Index	15-1
15.1	Keyword Index	15-1
15.2	Register Index	15-6

1 Introduction

The XC866 is a member of the high-performance XC800 family of 8-bit microcontrollers. It is based on the XC800 Core that is compatible with the industry standard 8051 processor. The XC866 features a great number of enhancements to enable new application technologies through its highly integrated on-chip components, such as on-chip oscillator or an integrated voltage regulator, allowing a single voltage supply of 3.0 to 5.5 V. In addition, the XC866 is equipped with either embedded Flash memory to offer high flexibility in development and ramp-up, or compatible ROM versions to provide cost-saving potential in high-volume production.

The multi-bank Flash architecture supports In-Application Programming (IAP), allowing user program to run from one bank, while programming or erasing another bank. In-System Programming (ISP) is available through the Boot ROM-based Boot Strap Loader (BSL), enabling convenient programming and erasing of the embedded Flash via an external host (e.g., personal computer).

Other key features of the XC866 include a Capture/Compare Unit 6 (CCU6) for the generation of pulse width modulated signal with special modes for motor control, and a 10-bit Analog-to-Digital Converter (ADC) with extended functionalities like autoscan and result accumulation for anti-aliasing filtering or for averaging. Local Interconnect Network (LIN) applications are also supported through extended UART features and the provision of LIN low level drivers for most devices. For low power applications, various power saving modes are available for selection by the user. Control of the numerous on-chip peripheral functionalities is achieved by extending the Special Function Register (SFR) address range with an intelligent paging mechanism optimized for interrupt handling.

Figure 1-1 shows the functional units of the XC866.

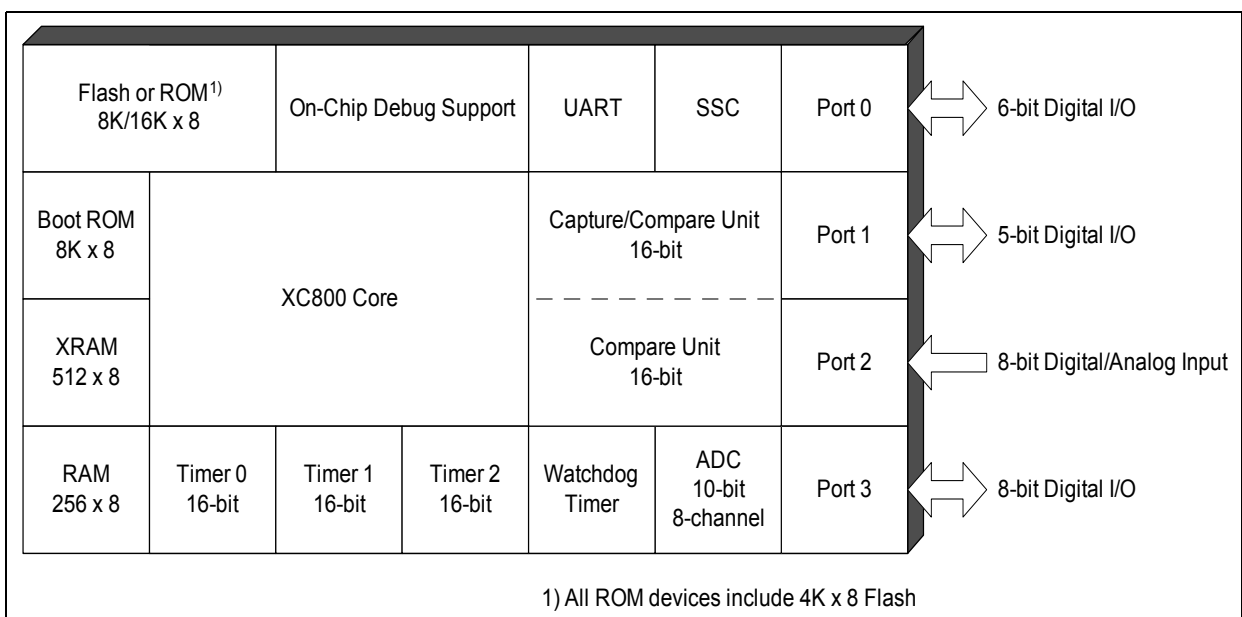

Figure 1-1 XC866 Functional Units

The XC866 product family features eight devices with different configurations and program memory sizes, offering cost-effective solution for different application requirements. In general, each device contains a non-volatile 8K × 8 read-only program memory, a volatile 768 × 8 read/write data memory, four ports, three 16-bit timers, a 16-bit capture/compare unit, a 16-bit compare timer, 14 interrupt vectors (and an NMI), four priority-level interrupt structure, two serial ports, versatile fail-safe mechanisms, on-chip debugging support logic and a 10-bit ADC.

The list of XC866 devices and their differences are summarized in [Table 1-1](#).

Table 1-1 Device Summary

Device Type	Device Name	Flash Size	ROM Size	LIN Support
Flash	XC866L-4FR	16 Kbytes	–	Yes
	XC866-4FR	16 Kbytes	–	No
	XC866L-2FR	8 Kbytes	–	Yes
	XC866-2FR	8 Kbytes	–	No
ROM	XC866L-4RR	4 Kbytes	16 Kbytes	Yes
	XC866-4RR	4 Kbytes	16 Kbytes	No
	XC866L-2RR	4 Kbytes	8 Kbytes	Yes
	XC866-2RR	4 Kbytes	8 Kbytes	No

The term “XC866” in this document refers to all devices of the XC866 family unless otherwise stated.

1.1 Feature Summary

The following list summarizes the main features of the XC866:

- High-performance XC800 Core
 - compatible with standard 8051 processor
 - two clocks per machine cycle architecture (for memory access without wait state)
 - two data pointers
- On-chip memory
 - 8 Kbytes of Boot ROM
 - 256 bytes of RAM
 - 512 bytes of XRAM
 - 8/16 Kbytes of Flash; or
8/16 Kbytes of ROM, with additional 4 Kbytes of Flash
- I/O port supply at 3.0 to 5.5 V and core logic supply at 2.5 V (generated by embedded voltage regulator)
- Power-on reset generation
- Brownout detection for core logic supply
- On-chip OSC and PLL for clock generation
 - PLL loss-of-lock detection
- Power saving modes
 - slow-down mode
 - idle mode
 - power-down mode with wake-up capability via RXD or EXINT0
 - clock gating control to each peripheral
- Programmable 16-bit Watchdog Timer (WDT)
- Four ports
 - 19 pins as digital I/O
 - 8 pins as digital/analog input
- 8-channel, 10-bit ADC
- Three 16-bit timers
 - Timer 0 and Timer 1 (T0 and T1)
 - Timer 2
- Capture/compare unit for PWM signal generation (CCU6)
- Full-duplex serial interface (UART)
- Synchronous serial channel (SSC)
- On-chip debug support
 - 1 Kbyte of monitor ROM (part of the 8-Kbyte Boot ROM)
 - 64 bytes of monitor RAM
- PG-TSSOP-38 pin package
- Temperature range T_A :
 - SAF (-40 to 85 °C)
 - SAK (-40 to 125 °C)

The block diagram of the XC866 is shown in **Figure 1-2**.

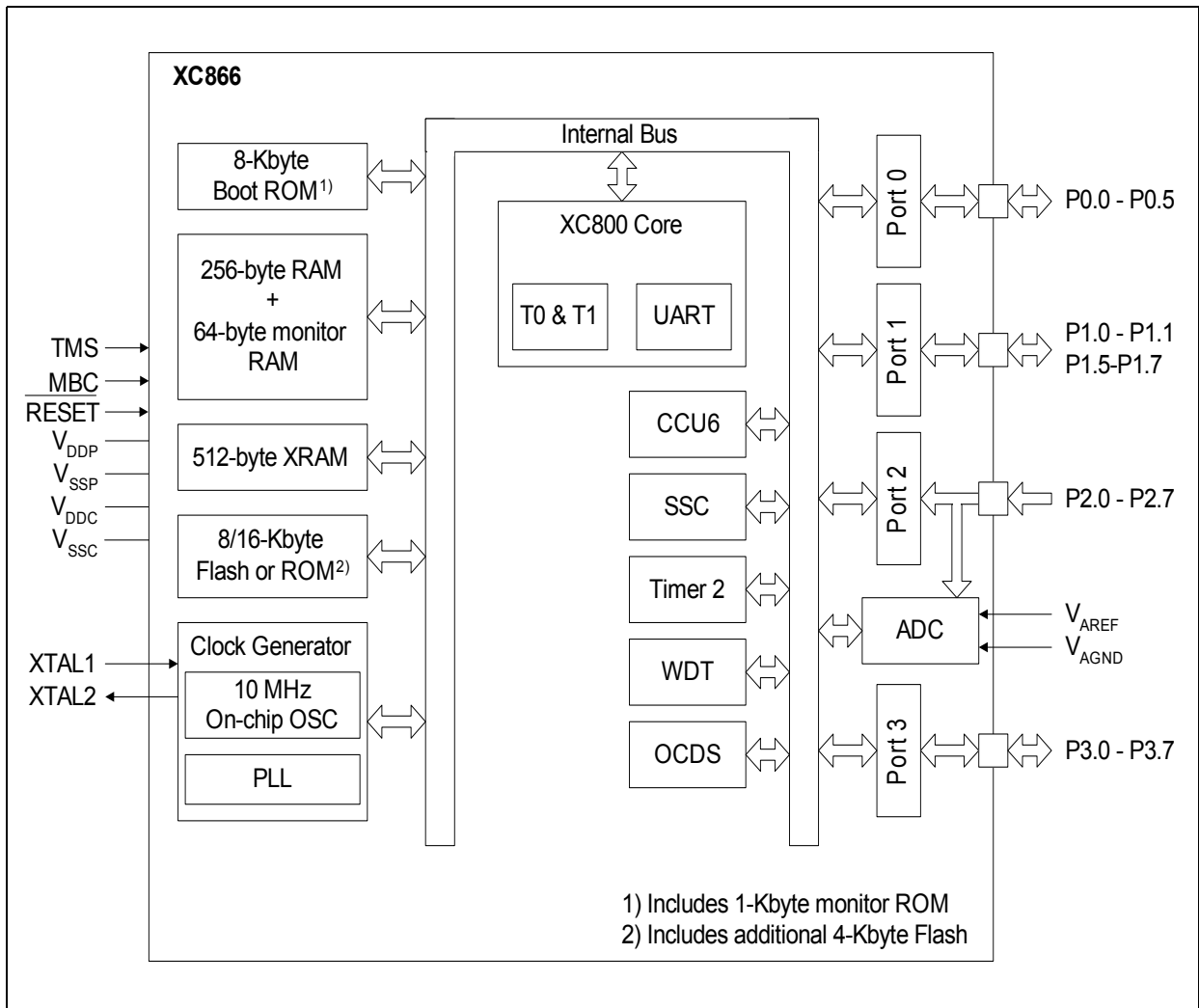

Figure 1-2 XC866 Block Diagram

1.2 Pin Configuration

The pin configuration of the XC866, based on the PG-TSSOP-38 package, is shown in [Figure 1-3](#).

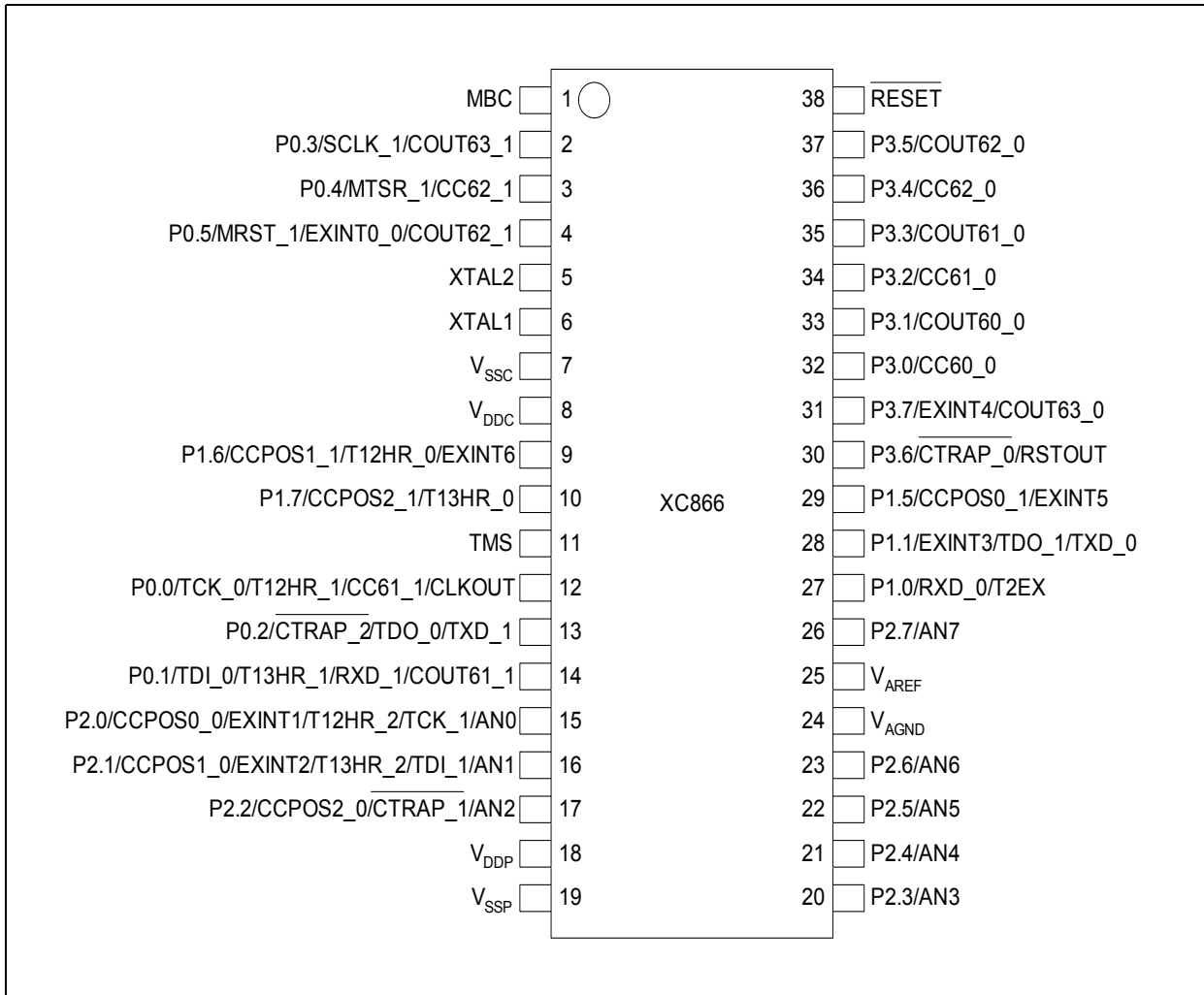

Figure 1-3 XC866 Pin Configuration, PG-TSSOP-38 Package (top view)

1.3 Pin Definitions and Functions

After reset, all pins are configured as input with one of the following:

- Pull-up device enabled (PU)
- Pull-down device enabled (PD)
- High impedance with both pull-up and pull-down devices disabled (Hi-Z)

The functions and default states of the XC866 external pins are provided in [Table 1-2](#).

Table 1-2 Pin Definitions and Functions

Symbol	Pin Number	Type	Reset State	Function
P0		I/O		Port 0 Port 0 is a 6-bit bidirectional general purpose I/O port. It can be used as alternate functions for the JTAG, CCU6, UART, and the SSC.
P0.0	12		Hi-Z	TCK_0 JTAG Clock Input T12HR_1 CCU6 Timer 12 Hardware Run Input CC61_1 Input/Output of Capture/Compare channel 1 CLKOUT 10 MHz On-Chip OSC Clock Output
P0.1	14		Hi-Z	TDI_0 JTAG Serial Data Input T13HR_1 CCU6 Timer 13 Hardware Run Input RXD_1 UART Receive Input COUT61_1 Output of Capture/Compare channel 1
P0.2	13		PU	CTRAP_2 CCU6 Trap Input TDO_0 JTAG Serial Data Output TXD_1 UART Transmit Output
P0.3	2		Hi-Z	SCK_1 SSC Clock Input/Output COUT63_1 Output of Capture/Compare channel 3
P0.4	3		Hi-Z	MTSR_1 SSC Master Transmit Output/ Slave Receive Input CC62_1 Input/Output of Capture/Compare channel 2

Table 1-2 Pin Definitions and Functions (cont'd)

Symbol	Pin Number	Type	Reset State	Function
P0.5	4		Hi-Z	MRST_1 SSC Master Receive Input/ Slave Transmit Output EXINT0_0 External Interrupt Input 0 COUT62_1 Output of Capture/Compare channel 2

Table 1-2 Pin Definitions and Functions (cont'd)

Symbol	Pin Number	Type	Reset State	Function
P1		I/O		Port 1 Port 1 is a 5-bit bidirectional general purpose I/O port. It can be used as alternate functions for the JTAG, CCU6, UART, and the SSC.
P1.0	27		PU	RXD_0 UART Receive Input T2EX Timer 2 External Trigger Input
P1.1	28		PU	EXINT3 External Interrupt Input 3 TDO_1 JTAG Serial Data Output TXD_0 UART Transmit Output
P1.5	29		PU	CCPOS0_1 CCU6 Hall Input 0 EXINT5 External Interrupt Input 5
P1.6	9		PU	CCPOS1_1 CCU6 Hall Input 1 T12HR_0 CCU6 Timer 12 Hardware Run Input
P1.7	10		PU	EXINT6 External Interrupt Input 6 CCPOS2_1 CCU6 Hall Input 2 T13HR_0 CCU6 Timer 13 Hardware Run Input
				P1.5 and P1.6 can be used as a software chip select output for the SSC.

Table 1-2 Pin Definitions and Functions (cont'd)

Symbol	Pin Number	Type	Reset State	Function
P2		I		Port 2 Port 2 is an 8-bit general purpose input-only port. It can be used as alternate functions for the digital inputs of the JTAG and CCU6. It is also used as the analog inputs for the ADC.
P2.0	15		Hi-Z	CCPOS0_0 CCU6 Hall Input 0 EXINT1 External Interrupt Input 1 T12HR_2 CCU6 Timer 12 Hardware Run Input TCK_1 JTAG Clock Input AN0 Analog Input 0
P2.1	16		Hi-Z	CCPOS1_0 CCU6 Hall Input 1 EXINT2 External Interrupt Input 2 T13HR_2 CCU6 Timer 13 Hardware Run Input TDI_1 JTAG Serial Data Input AN1 Analog Input 1
P2.2	17		Hi-Z	CCPOS2_0 CCU6 Hall Input 2 CTRAP_1 CCU6 Trap Input AN2 Analog Input 2
P2.3	20		Hi-Z	AN3 Analog Input 3
P2.4	21		Hi-Z	AN4 Analog Input 4
P2.5	22		Hi-Z	AN5 Analog Input 5
P2.6	23		Hi-Z	AN6 Analog Input 6
P2.7	26		Hi-Z	AN7 Analog Input 7

Table 1-2 Pin Definitions and Functions (cont'd)

Symbol	Pin Number	Type	Reset State	Function
P3		I		Port 3 Port 3 is a bidirectional general purpose I/O port. It can be used as alternate functions for the CCU6.
P3.0	32		Hi-Z	CC60_0 Input/Output of Capture/Compare channel 0
P3.1	33		Hi-Z	COOUT60_0 Output of Capture/Compare channel 0
P3.2	34		Hi-Z	CC61_0 Input/Output of Capture/Compare channel 1
P3.3	35		Hi-Z	COOUT61_0 Output of Capture/Compare channel 1
P3.4	36		Hi-Z	CC62_0 Input/Output of Capture/Compare channel 2
P3.5	37		Hi-Z	COOUT62_0 Output of Capture/Compare channel 2
P3.6	30		PD	$\overline{\text{CTRAP_0}}$ CCU6 Trap Input RSTOUT Reset output indication for internal reset condition in microcontroller
P3.7	31		Hi-Z	EXINT4 External Interrupt Input 4 COOUT63_0 Output of Capture/Compare channel 3

Table 1-2 Pin Definitions and Functions (cont'd)

Symbol	Pin Number	Type	Reset State	Function
V_{DDP}	18	–	–	I/O Port Supply (3.0 - 5.5 V)
V_{SSP}	19	–	–	I/O Port Ground
V_{DDC}	8	–	–	Core Supply Output (2.5 V)
V_{SSC}	7	–	–	Core Supply Ground
V_{AREF}	25	–	–	ADC Reference Voltage
V_{AGND}	24	–	–	ADC Reference Ground
XTAL1	6	I	Hi-Z	External Oscillator Input (backup for on-chip OSC, normally NC)
XTAL2	5	O	Hi-Z	External Oscillator Output (backup for on-chip OSC, normally NC)
TMS	11	I	PD	Test Mode Select
RESET	38	I	PU	Reset Input for PG-TSSOP-38 package
MBC	1	I	PU	Monitor & BootStrap Loader Control

1.4 Textual Convention

This document uses the following textual conventions for named components of the XC866:

- Functional units of the XC866 are shown in upper case. For example: “The SSC can be used to communicate with shift registers.”
- Pins using negative logic are indicated by an overbar. For example: “A reset input pin $\overline{\text{RESET}}$ is provided for the hardware reset.”
- Bit fields and bits in registers are generally referenced as “Register name.Bit field” or “Register name.Bit”. Most of the register names contain a module name prefix, separated by an underscore character “_” from the actual register name. In the example of “SSC_CON”, “SSC” is the module name prefix, and “CON” is the actual register name).
- Variables that are used to represent sets of processing units or registers appear in mixed-case type. For example, the register name “CC6xR” refers to multiple “CC6xR” registers with the variable x (x = 0, 1, 2). The bounds of the variables are always specified where the register expression is first used (e.g., “x = 0 - 2”), and is repeated as needed.
- The default radix is decimal. Hexadecimal constants have a suffix with the subscript letter “H” (e.g., C0_H). Binary constants have a suffix with the subscript letter “B” (e.g., 11_B).
- When the extents of register fields, groups of signals, or groups of pins are collectively named in the body of the document, they are represented as “NAME[A:B]”, which defines a range, from B to A, for the named group. Individual bits, signals, or pins are represented as “NAME[C]”, with the range of the variable C provided in the text (e.g., CFG[2:0] and TOS[0]).
- Units are abbreviated as follows:
 - **MHz** = Megahertz
 - **μs** = Microseconds
 - **kBaud, kbit** = 1000 characters/bits per second
 - **MBaud, Mbit** = 1,000,000 characters/bits per second
 - **Kbyte** = 1024 bytes of memory
 - **Mbyte** = 1,048,576 bytes of memory

In general, the *k* prefix scales a unit by 1000 whereas the *K* prefix scales a unit by 1024. Hence, the Kbyte unit scales the expression preceding it by 1024. The kBaud unit scales the expression preceding it by 1000. The *M* prefix scales by 1,000,000 or 1,048,576, and μ scales by 0.000001. For example, 1 Kbyte is 1024 bytes, 1 Mbyte is 1024 × 1024 bytes, 1 kBaud/kbit are 1000 characters/bits per second, 1 MBaud/Mbit are 1,000,000 characters/bits per second, and 1 MHz is 1,000,000 Hz.
- Data format quantities are defined as follows:
 - **byte** = 8-bit quantity

1.5 Reserved, Undefined and Unimplemented Terminology

In tables where register bit fields are defined, the following conventions are used to indicate undefined and unimplemented function. Further, types of bits and bit fields are defined using the abbreviations shown in [Table 1-3](#).

Table 1-3 Bit Function Terminology

Function of Bits	Description
Unimplemented	Register bit fields named “0” indicate unimplemented functions with the following behavior. <ul style="list-style-type: none"> – Reading these bit fields returns 0. – Writing to these bit fields has no effect. These bit fields are reserved. When writing, software should always set such bit fields to 0 in order to preserve compatibility with future products. Setting the bit fields to 1 may lead to unpredictable results.
Undefined	Certain bit combinations in a bit field can be labeled “Reserved”, indicating that the behavior of the XC866 is undefined for that combination of bits. Setting the register to undefined bit combinations may lead to unpredictable results. Such bit combinations are reserved. When writing, software must always set such bit fields to legal values as provided in the bit field description tables.
rw	The bit or bit field can be read and written.
r	The bit or bit field can only be read (read-only).
w	The bit or bit field can only be written (write-only). Reading always return 0.
h	The bit or bit field can also be modified by hardware (such as a status bit). This attribute can be combined with ‘rw’ or ‘r’ bits to ‘rwh’ and ‘rh’ bits, respectively.

1.6 Acronyms

Table 1-4 lists the acronyms used in this document.

Table 1-4 Acronyms

ADC	Analog-to-Digital Converter
ALU	Arithmetic/Logic Unit
BSL	BootStrap Loader
CCU6	Capture/Compare Unit 6
CGU	Clock Generation Unit
CPU	Central Processing Unit
ECC	Error Correction Code
EVR	Embedded Voltage Regulator
FIFO	First-In First-Out
GPIO	General Purpose I/O
IAP	In-Application Programming
I/O	Input/Output
ISP	In-System Programming
JTAG	Joint Test Action Group
LIN	Local Interconnect Network
NMI	Non-Maskable Interrupt
OCDS	On-Chip Debug Support
PC	Program Counter
POR	Power-On Reset
PLL	Phase-Locked Loop
PSW	Program Status Word
PWM	Pulse Width Modulation
RAM	Random Access Memory
ROM	Read-Only Memory
SFR	Special Function Register
SPI	Serial Peripheral Interface
SSC	Synchronous Serial Controller
UART	Universal Asynchronous Receiver/Transmitter
WDT	Watchdog Timer

2 Processor Architecture

The XC866 is based on a high-performance 8-bit Central Processing Unit (CPU) that is compatible with the standard 8051 processor. While the standard 8051 processor is designed around a 12-clock machine cycle, the XC866 CPU uses a 2-clock machine cycle. This allows fast access to ROM or RAM memories without wait state. Access to the Flash memory, however, requires an additional wait state (one machine cycle). See [Section 2.3](#). The instruction set consists of 45% one-byte, 41% two-byte and 14% three-byte instructions.

The XC866 CPU provides a range of debugging features, including basic stop/start, single-step execution, breakpoint support and read/write access to the data memory, program memory and SFRs.

Features:

- Two clocks per machine cycle architecture (for memory access without wait state)
- Wait state support for Flash memory
- Program memory download option
- 15-source, 4-level interrupt controller
- Two data pointers
- Power saving modes
- Dedicated debug mode and debug signals
- Two 16-bit timers (Timer 0 and Timer 1)
- Full-duplex serial port (UART)

2.1 Functional Description

Figure 2-1 shows the CPU functional blocks. The CPU consists of the instruction decoder, the arithmetic section, and the program control section. Each program instruction is decoded by the instruction decoder. This instruction decoder generates internal signals that control the functions of the individual units within the CPU. The internal signals have an effect on the source and destination of data transfers and control the arithmetic/logic unit (ALU) processing.

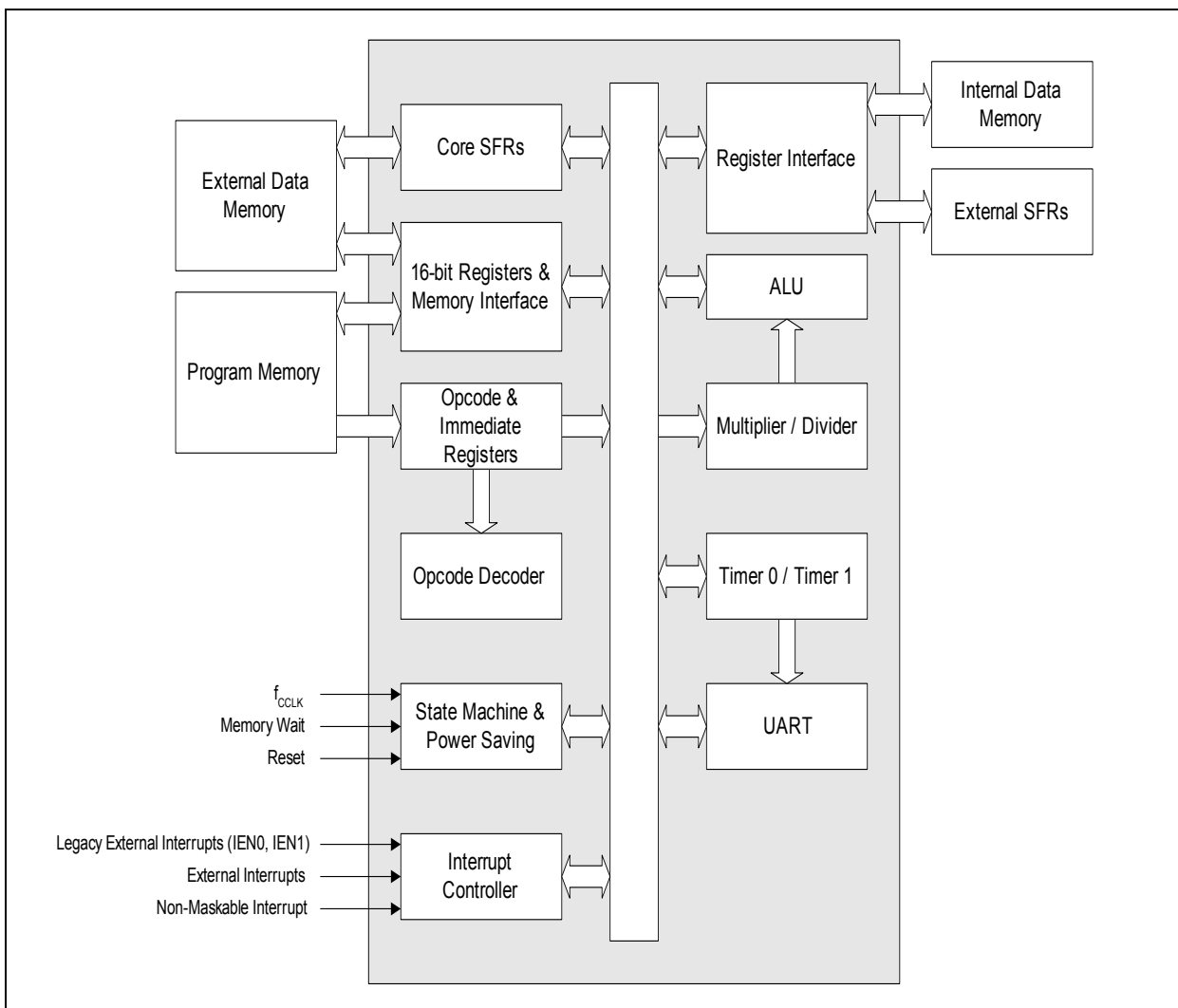

Figure 2-1 CPU Block Diagram

Processor Architecture

The arithmetic section of the processor performs extensive data manipulation and consists of the ALU, ACC register, B register, and PSW register.

The ALU accepts 8-bit data words from one or two sources, and generates an 8-bit result under the control of the instruction decoder. The ALU performs both arithmetic and logic operations. Arithmetic operations include add, subtract, multiply, divide, increment, decrement, BCD-decimal-add-adjust, and compare. Logic operations include AND, OR, Exclusive OR, complement, and rotate (right, left, or swap nibble (left four)). Also included is a Boolean processor performing the bit operations such as set, clear, complement, jump-if-set, jump-if-not-set, jump-if-set-and-clear, and move to/from carry. The ALU can perform the bit operations of logical AND or logical OR between any addressable bit (or its complement) and the carry flag, and place the new result in the carry flag.

The program control section controls the sequence in which the instructions stored in program memory are executed. The 16-bit Program Counter (PC) holds the address of the next instruction to be executed. The conditional branch logic enables internal and external events to the processor to cause a change in the program execution sequence.

2.2 CPU Register Description

The CPU registers occupy direct Internal Data Memory space locations in the range 80_H to FF_H.

2.2.1 Stack Pointer (SP)

The SP register contains the Stack Pointer (SP). The SP is used to load the Program Counter (PC) into Internal Data Memory during LCALL and ACALL instructions, and to retrieve the PC from memory during RET and RETI instructions. Data may also be saved on or retrieved from the stack using PUSH and POP instructions, respectively. Instructions that use the stack automatically pre-increment or post-decrement the stack pointer so that the stack pointer always points to the last byte written to the stack, i.e., the top of the stack. On reset, the SP is reset to 07_H. This causes the stack to begin at a location = 08_H above register bank zero. The SP can be read or written under software control.

2.2.2 Data Pointer (DPTR)

The Data Pointer (DPTR) is stored in registers DPL (Data Pointer Low byte) and DPH (Data Pointer High byte) to form 16-bit addresses for External Data Memory accesses (MOVX A,@DPTR and MOVX @DPTR,A), for program byte moves (MOVC A,@A+DPTR), and for indirect program jumps (JMP @A+DPTR).

Two true 16-bit operations are allowed on the Data Pointer: load immediate (MOV DPTR,#data) and increment (INC DPTR).

2.2.3 Accumulator (ACC)

This register provides one of the operands for most ALU operations. While ACC is the symbol for the accumulator register, the mnemonics for accumulator-specific instructions refer to the accumulator simply as "A".

2.2.4 B Register

The B register is used during multiply and divide operations to provide the second operand. For other instructions, it can be treated as another scratch pad register.

2.2.5 Program Status Word

The Program Status Word (PSW) contains several status bits that reflect the current state of the CPU.

PSW

Program Status Word Register

Reset Value: 00_H

7	6	5	4	3	2	1	0
CY	AC	F0	RS1	RS0	OV	F1	P
rw	rwh	rwh	rw	rw	rwh	rwh	rh

Field	Bits	Type	Description															
P	0	rh	Parity Flag Set/cleared by hardware after each instruction to indicate an odd/even number of “one” bits in the accumulator, i.e., even parity.															
F1	1	rwh	General Purpose Flag															
OV	2	rwh	Overflow Flag Used by arithmetic instructions															
RS0 RS1	3 4	rw	Register Bank Select These bits are used to select one of the four register banks. <table border="1" style="width: 100%; border-collapse: collapse;"> <thead> <tr> <th>RS1</th> <th>RS0</th> <th>Function</th> </tr> </thead> <tbody> <tr> <td style="text-align: center;">0</td> <td style="text-align: center;">0</td> <td>Bank 0 selected, data address 00_H-07_H</td> </tr> <tr> <td style="text-align: center;">0</td> <td style="text-align: center;">1</td> <td>Bank 1 selected, data address 08_H-0F_H</td> </tr> <tr> <td style="text-align: center;">1</td> <td style="text-align: center;">0</td> <td>Bank 2 selected, data address 10_H-17_H</td> </tr> <tr> <td style="text-align: center;">1</td> <td style="text-align: center;">1</td> <td>Bank 3 selected, data address 18_H-1F_H</td> </tr> </tbody> </table>	RS1	RS0	Function	0	0	Bank 0 selected, data address 00 _H -07 _H	0	1	Bank 1 selected, data address 08 _H -0F _H	1	0	Bank 2 selected, data address 10 _H -17 _H	1	1	Bank 3 selected, data address 18 _H -1F _H
RS1	RS0	Function																
0	0	Bank 0 selected, data address 00 _H -07 _H																
0	1	Bank 1 selected, data address 08 _H -0F _H																
1	0	Bank 2 selected, data address 10 _H -17 _H																
1	1	Bank 3 selected, data address 18 _H -1F _H																
F0	5	rwh	General Purpose Flag															
AC	6	rwh	Auxiliary Carry Flag Used by instructions that execute BCD operations															
CY	7	rw	Carry Flag Used by arithmetic instructions															

2.2.6 Extended Operation Register (EO)

The instruction set includes an additional instruction `MOVC @(DPTR++),A` which allows program memory to be written. This instruction may be used to download code into the program memory when the CPU is initialized and subsequently, also to provide software updates. The instruction copies the contents of the accumulator to the code memory at the location pointed to by the current data pointer, and then increments the data pointer.

The instruction uses the opcode `A5H`, which is the same as the software break instruction `TRAP` (see [Table 2-1](#)). Register bit `EO.TRAP_EN` is used to select the instruction executed by the opcode `A5H`. When `TRAP_EN` is 0 (default), the `A5H` opcode executes the `MOVC` instruction. When `TRAP_EN` is 1, the `A5H` opcode executes the software break instruction `TRAP`, which switches the CPU to debug mode for breakpoint processing.

EO

Extended Operation Register

Reset Value: `00H`

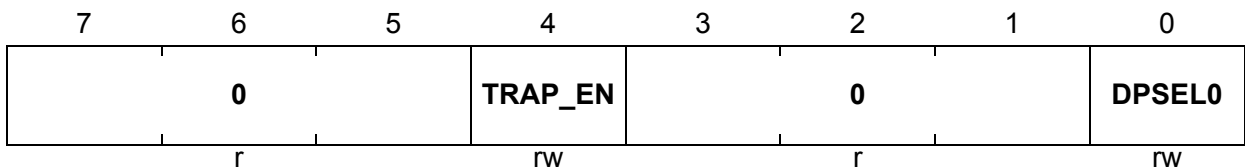

Field	Bits	Type	Description
DPSEL0	0	rw	Data Pointer Select 0 DPTR0 is selected. 1 DPTR1 is selected.
TRAP_EN	4	rw	TRAP Enable 0 Select <code>MOVC @(DPTR++),A</code> 1 Select software <code>TRAP</code> instruction
0	[3:1], [7:5]	r	Reserved Returns 0 if read; should be written with 0.

2.2.7 Power Control Register (PCON)

The CPU has two power-saving modes: idle mode and power-down mode. The idle mode can be entered via the PCON register. In idle mode, the clock to the CPU is stopped while the timers, serial port and interrupt controller continue to run using a half-speed clock. In power-down mode, the clock to the entire CPU is stopped.

PCON

Power Control Register

Reset Value: 00_H

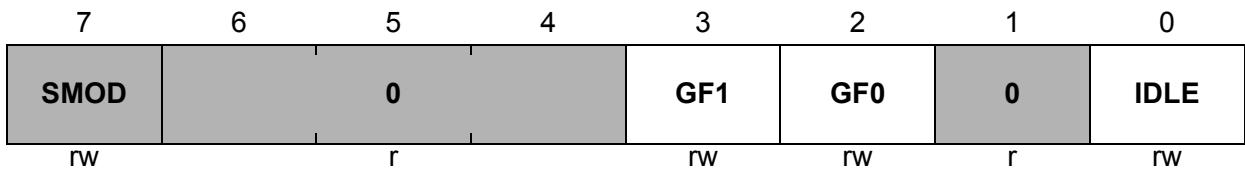

The functions of the shaded bits are not described here

Field	Bits	Type	Description
IDLE	0	rw	Idle Mode Enable 0 Do not enter idle mode 1 Enter idle mode
GF0	2	rw	General Purpose Flag Bit 0
GF1	3	rw	General Purpose Flag Bit 1

2.3 Instruction Timing

For memory access without wait state, a CPU machine cycle comprises two input clock periods referred to as Phase 1 (P1) and Phase 2 (P2) that correspond to two different CPU states. A CPU state within an instruction is denoted by reference to the machine cycle and state number, e.g., C2P1 is the first clock period within machine cycle 2. Memory accesses take place during one or both phases of the machine cycle. SFR writes only occur at the end of P2. An instruction takes one, two or four machine cycles to execute. Registers are generally updated and the next opcode read at the end of P2 of the last machine cycle for the instruction.

With each access to the Flash memory, instruction execution times are extended by one machine cycle (one wait state), starting from either P1 or P2.

Figure 2-2 shows the fetch/execute timing related to the internal states and phases. Execution of an instruction occurs at C1P1. For a 2-byte instruction, the second reading starts at C1P1.

Figure 2-2 (a) shows two timing diagrams for a 1-byte, 1-cycle ($1 \times$ machine cycle) instruction. The first diagram shows the instruction being executed within one machine cycle since the opcode (C1P2) is fetched from a memory without wait state. The second diagram shows the corresponding states of the same instruction being executed over two machine cycles (instruction time extended), with one wait state inserted for opcode fetching from the Flash memory.

Figure 2-2 (b) shows two timing diagrams for a 2-byte, 1-cycle ($1 \times$ machine cycle) instruction. The first diagram shows the instruction being executed within one machine cycle since the second byte (C1P1) and the opcode (C1P2) are fetched from a memory without wait state. The second diagram shows the corresponding states of the same instruction being executed over three machine cycles (instruction time extended), with one wait state inserted for each access to the Flash memory (two wait states inserted in total).

Figure 2-2 (c) shows two timing diagrams of a 1-byte, 2-cycle ($2 \times$ machine cycle) instruction. The first diagram shows the instruction being executed over two machine cycles with the opcode (C2P2) fetched from a memory without wait state. The second diagram shows the corresponding states of the same instruction being executed over three machine cycles (instruction time extended), with one wait state inserted for opcode fetching from the Flash memory.

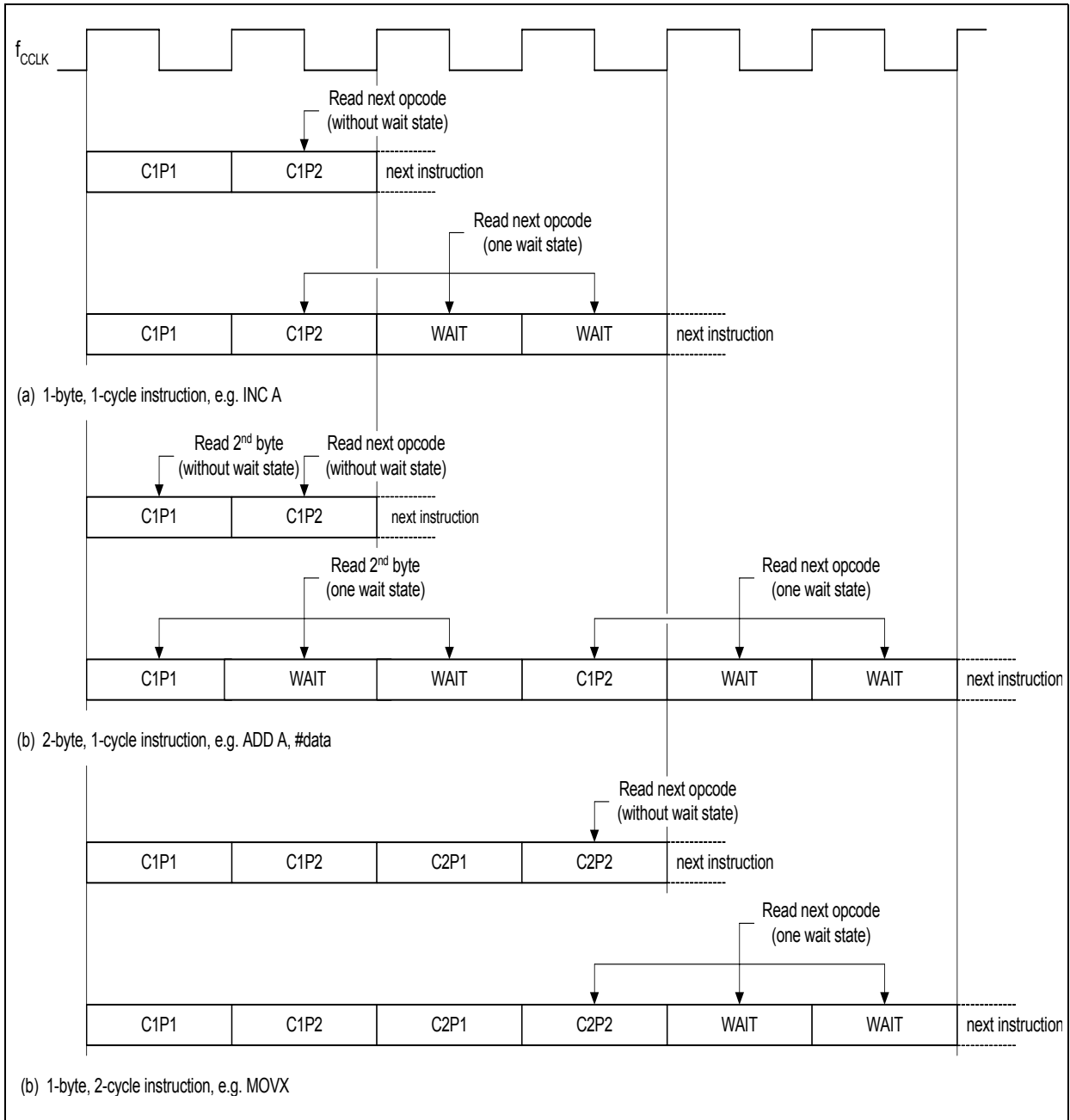

Figure 2-2 CPU Instruction Timing

Processor Architecture

Instructions are 1, 2 or 3 bytes long as indicated in the “Bytes” column of **Table 2-1**. For the XC866, the time taken for each instruction includes:

- decoding/executing the fetched opcode
- fetching the operand/s (for instructions > 1 byte)
- fetching the first byte (opcode) of the next instruction (due to XC866 CPU pipeline)

Note: The XC866 CPU fetches the opcode of the next instruction while executing the current instruction.

Table 2-1 provides a reference for the number of clock cycles required by each instruction. The first value applies to fetching operand(s) and opcode from fast program memory (e.g., Boot ROM and XRAM) without wait state. The second value applies to fetching operand(s) and opcode from slow program memory (e.g., Flash) with one wait state inserted. The instruction time for the standard 8051 processor is provided in the last column for performance comparison with the XC866 CPU. Even with one wait state inserted for each byte of operand/opcode fetched, the XC866 CPU executes instructions faster than the standard 8051 processor by a factor of between two (e.g., 2-byte, 1-cycle instructions) to six (e.g., 1-byte, 4-cycle instructions).

Table 2-1 CPU Instruction Timing

Mnemonic	Hex Code	Bytes	Number of f_{CLK} Cycles		
			XC866		8051
			no ws	1 ws	
ARITHMETIC					
ADD A,Rn	28-2F	1	2	4	12
ADD A,dir	25	2	2	6	12
ADD A,@Ri	26-27	1	2	4	12
ADD A,#data	24	2	2	6	12
ADDC A,Rn	38-3F	1	2	4	12
ADDC A,dir	35	2	2	6	12
ADDC A,@Ri	36-37	1	2	4	12
ADDC A,#data	34	2	2	6	12
SUBB A,Rn	98-9F	1	2	4	12
SUBB A,dir	95	2	2	6	12
SUBB A,@Ri	96-97	1	2	4	12
SUBB A,#data	94	2	2	6	12
INC A	04	1	2	4	12
INC Rn	08-0F	1	2	4	12

Table 2-1 CPU Instruction Timing (cont'd)

Mnemonic	Hex Code	Bytes	Number of f_{CLK} Cycles		
			XC866		8051
			no ws	1 ws	
INC dir	05	2	2	6	12
INC @Ri	06-07	1	2	4	12
DEC A	14	1	2	4	12
DEC Rn	18-1F	1	2	4	12
DEC dir	15	2	2	6	12
DEC @Ri	16-17	1	2	4	12
INC DPTR	A3	1	4	4	24
MUL AB	A4	1	8	8	48
DIV AB	84	1	8	8	48
DA A	D4	1	2	4	12
LOGICAL					
ANL A,Rn	58-5F	1	2	4	12
ANL A,dir	55	2	2	6	12
ANL A,@Ri	56-57	1	2	4	12
ANL A,#data	54	2	2	6	12
ANL dir,A	52	2	2	6	12
ANL dir,#data	53	3	4	10	24
ORL A,Rn	48-4F	1	2	4	12
ORL A,dir	45	2	2	6	12
ORL A,@Ri	46-47	1	2	4	12
ORL A,#data	44	2	2	6	12
ORL dir,A	42	2	2	6	12
ORL dir,#data	43	3	4	10	24
XRL A,Rn	68-6F	1	2	4	12
XRL A,dir	65	2	2	6	12
XRL A,@Ri	66-67	1	2	4	12
XRL A,#data	64	2	2	6	12
XRL dir,A	62	2	2	6	12

Table 2-1 CPU Instruction Timing (cont'd)

Mnemonic	Hex Code	Bytes	Number of f_{CLK} Cycles		
			XC866		8051
			no ws	1 ws	
XRL dir,#data	63	3	4	10	24
CLR A	E4	1	2	4	12
CPL A	F4	1	2	4	12
SWAP A	C4	1	2	4	12
RL A	23	1	2	4	12
RLC A	33	1	2	4	12
RR A	03	1	2	4	12
RRC A	13	1	2	4	12
DATA TRANSFER					
MOV A,Rn	E8-EF	1	2	4	12
MOV A,dir	E5	2	2	6	12
MOV A,@Ri	E6-E7	1	2	4	12
MOV A,#data	74	2	2	6	12
MOV Rn,A	F8-FF	1	2	4	12
MOV Rn,dir	A8-AF	2	4	8	24
MOV Rn,#data	78-7F	2	2	6	12
MOV dir,A	F5	2	2	6	12
MOV dir,Rn	88-8F	2	4	8	24
MOV dir,dir	85	3	4	10	24
MOV dir,@Ri	86-87	2	4	8	24
MOV dir,#data	75	3	4	10	24
MOV @Ri,A	F6-F7	1	2	4	12
MOV @Ri,dir	A6-A7	2	4	8	24
MOV @Ri,#data	76-77	2	2	6	12
MOV DPTR,#data	90	3	4	10	24
MOVC A,@A+DPTR	93	1	4	6	24
MOVC A,@A+PC	83	1	4	6	24
MOVX A,@Ri	E2-E3	1	4	6	24

Table 2-1 CPU Instruction Timing (cont'd)

Mnemonic	Hex Code	Bytes	Number of f_{CLK} Cycles		
			XC866		8051
			no ws	1 ws	
MOVX A,@DPTR	E0	1	4	6	24
MOVX @Ri,A	F2-F3	1	4	6	24
MOVX @DPTR,A	F0	1	4	6	24
PUSH dir	C0	2	4	8	24
POP dir	D0	2	4	8	24
XCH A,Rn	C8-CF	1	2	4	12
XCH A,dir	C5	2	2	6	12
XCH A,@Ri	C6-C7	1	2	4	12
XCHD A,@Ri	D6-D7	1	2	4	12
BOOLEAN					
CLR C	C3	1	2	4	12
CLR bit	C2	2	2	6	12
SETB C	D3	1	2	4	12
SETB bit	D2	2	2	6	12
CPL C	B3	1	2	4	12
CPL bit	B2	2	2	6	12
ANL C,bit	82	2	4	8	24
ANL C,/bit	B0	2	4	8	24
ORL C,bit	72	2	4	8	24
ORL C,/bit	A0	2	4	8	24
MOV C,bit	A2	2	2	6	12
MOV bit,C	92	2	4	8	24
BRANCHING					
ACALL addr11	11->F1	2	4	8	24
LCALL addr16	12	3	4	10	24
RET	22	1	4	4	24
RETI	32	1	4	4	24
AJMP addr 11	01->E1	2	4	8	24

Table 2-1 CPU Instruction Timing (cont'd)

Mnemonic	Hex Code	Bytes	Number of f_{CLK} Cycles		
			XC866		8051
			no ws	1 ws	
LJMP addr 16	02	3	4	10	24
SJMP rel	80	2	4	8	24
JC rel	40	2	4	8	24
JNC rel	50	2	4	8	24
JB bit,rel	20	3	4	10	24
JNB bit,rel	30	3	4	10	24
JBC bit,rel	10	3	4	10	24
JMP @A+DPTR	73	1	4	4	24
JZ rel	60	2	4	8	24
JNZ rel	70	2	4	8	24
CJNE A,dir,rel	B5	3	4	10	24
CJNE A,#d,rel	B4	3	4	10	24
CJNE Rn,#d,rel	B8-BF	3	4	10	24
CJNE @Ri,#d,rel	B6-B7	3	4	10	24
DJNZ Rn,rel	D8-DF	2	4	8	24
DJNZ dir,rel	D5	3	4	10	24
MISCELLANEOUS					
NOP	00	1	2	4	12
ADDITIONAL INSTRUCTIONS					
MOVC @(DPTR++),A	A5	1	4	4	–
TRAP	A5	1	2	tbd	–

3 Memory Organization

The XC866 CPU operates in the following five address spaces:

- 8 Kbytes of Boot ROM program memory
- 256 bytes of internal RAM data memory
- 512 bytes of XRAM memory
(XRAM can be read/written as program memory or external data memory)
- a 128-byte Special Function Register area
- 8/16 Kbytes of Flash program memory (Flash devices); or
8/16 Kbytes of ROM program memory, with additional 4 Kbytes of Flash
(ROM devices)

Figure 3-1 illustrates the memory address spaces of the 16-Kbyte Flash devices. For the 8-Kbyte Flash devices, the shaded banks are not available.

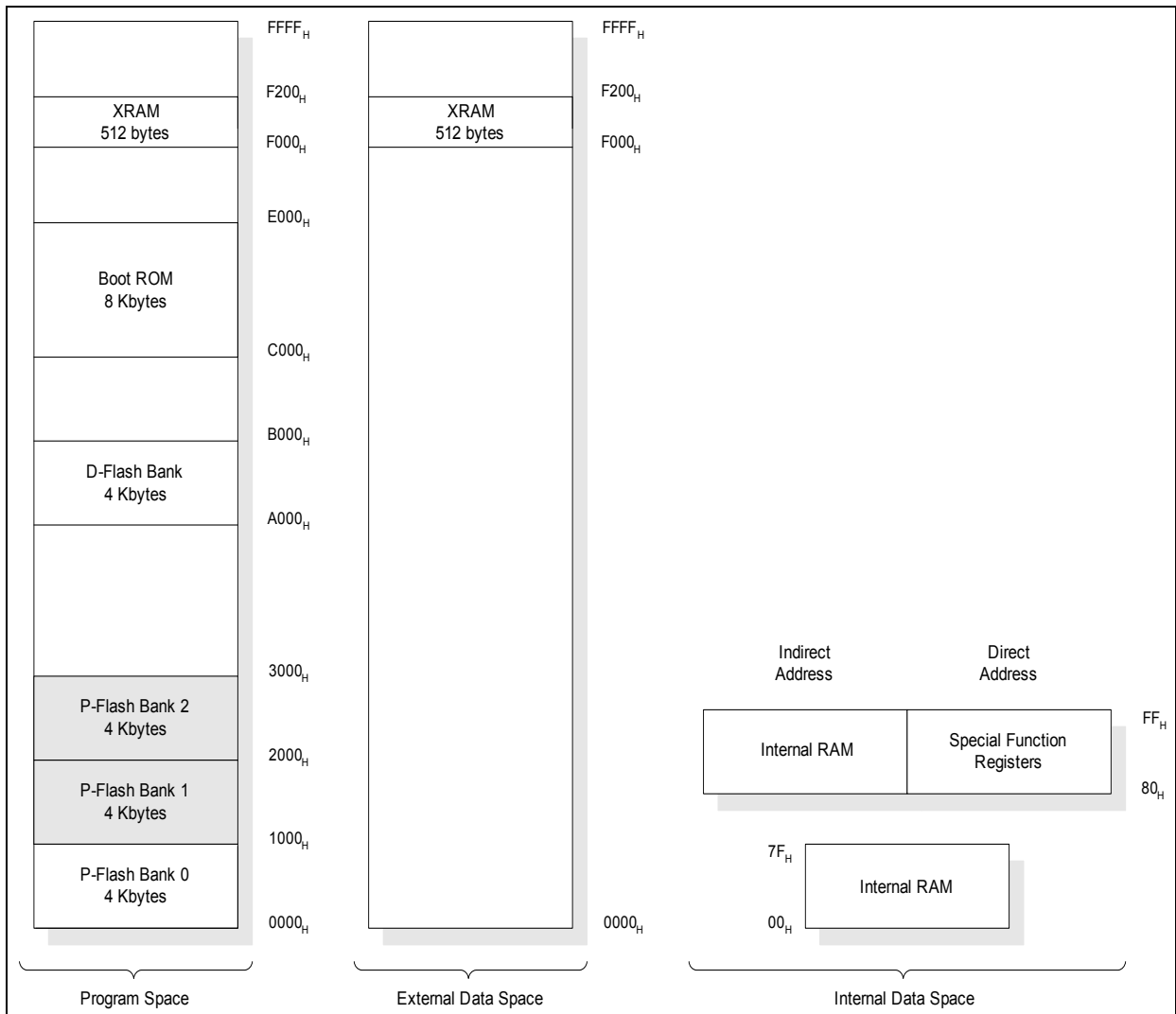

Figure 3-1 Memory Map of XC866 Flash Device

Memory Organization

Figure 3-2 illustrates the memory address spaces of the 16-Kbyte ROM devices. For the 8-Kbyte ROM devices, the shaded address regions are not available.

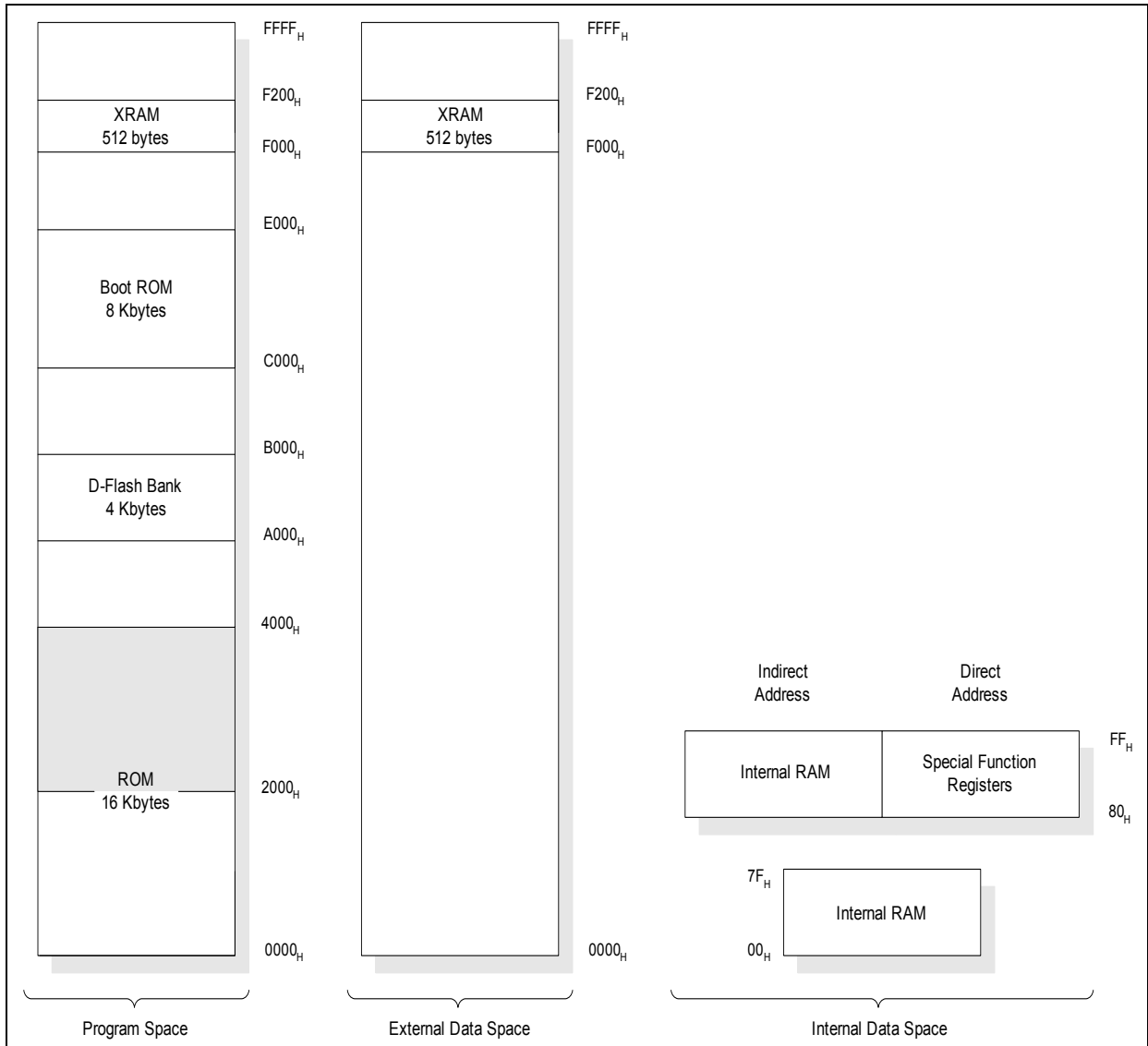

Figure 3-2 Memory Map of XC866 ROM Device

3.1 Program Memory

The performance of the CPU is optimized with a dedicated interface for direct interfacing with the program memory without using any port pin. This means that a code fetch can occur on every rising edge of the clock. Hence, there is no concept of 'internal' or 'external' program memory as all code is fetched from a single program memory interface.

3.2 Data Memory

The data memory space consists of an internal and external memory space. The labels 'internal' and 'external' for data memory are used to distinguish between the register memory and the 64-Kbyte data space accessed using 'MOVX' instructions. They do not imply that the external data memory is located off-chip.

3.2.1 Internal Data Memory

The internal data memory is divided into two physically separate and distinct blocks: the 256-byte RAM and the 128-byte Special Function Register (SFR) area. While the upper 128 bytes of RAM and the SFR area share the same address locations, they are accessed through different addressing modes. The lower 128 bytes of RAM can be accessed through either direct or register indirect addressing, while the upper 128 bytes of RAM can be accessed through register indirect addressing only. The SFRs are accessible through direct addressing.

The 16 bytes of RAM that occupy addresses from 20_H to 2F_H are bitaddressable. RAM occupying direct addresses from 30_H to 7F_H can be used as scratch pad registers or used for the stack.

3.2.2 External Data Memory

The 512-byte XRAM is mapped to both the external data memory area and the program memory area. It can be accessed using both 'MOVX' and 'MOVC' instructions.

3.3 Special Function Registers

The Special Function Registers (SFRs) occupy direct internal data memory space in the range 80_H to FF_H. All registers, except the program counter, reside in the SFR area. The SFRs include pointers and registers that provide an interface between the CPU and the on-chip peripherals. As the 128-SFR range is less than the total number of registers required, address extension mechanisms are required to increase the number of addressable SFRs. The address extension mechanisms include:

- Mapping
- Paging

3.3.1 Address Extension by Mapping

Address extension is performed at the system level by mapping. The SFR area is extended into two portions: the standard (non-mapped) SFR area and the mapped SFR area. Each portion supports the same address range 80_H to FF_H, bringing the number of addressable SFRs to 256. The extended address range is not directly controlled by the CPU instruction itself, but is derived from bit RMAP in the system control register SYSCON0 at address 8F_H. To access SFRs in the mapped area, bit RMAP in SFR SYSCON0 must be set. Alternatively, the SFRs in the standard area can be accessed by clearing bit RMAP. The SFR area can be selected as shown in [Figure 3-3](#).

SYSCON0

System Control Register 0

Reset Value: 00_H

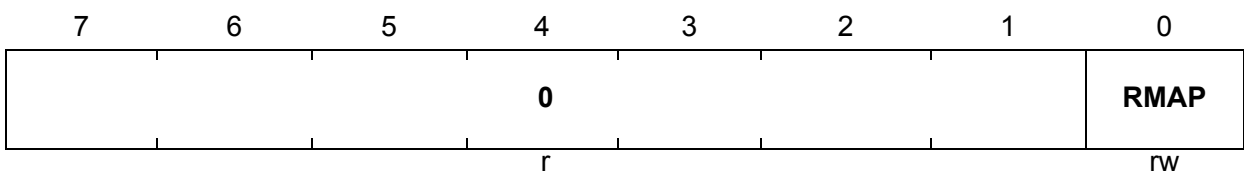

Field	Bits	Type	Description
RMAP	0	rw	Special Function Register Map Control 0 The access to the standard SFR area is enabled. 1 The access to the mapped SFR area is enabled.
0	[7:1]	r	Reserved Returns 0 if read; should be written with 0.

As long as bit RMAP is set, the mapped SFR area can be accessed. This bit is not cleared automatically by hardware. Thus, before standard/mapped registers are accessed, bit RMAP must be cleared/set, respectively, by software.

Memory Organization

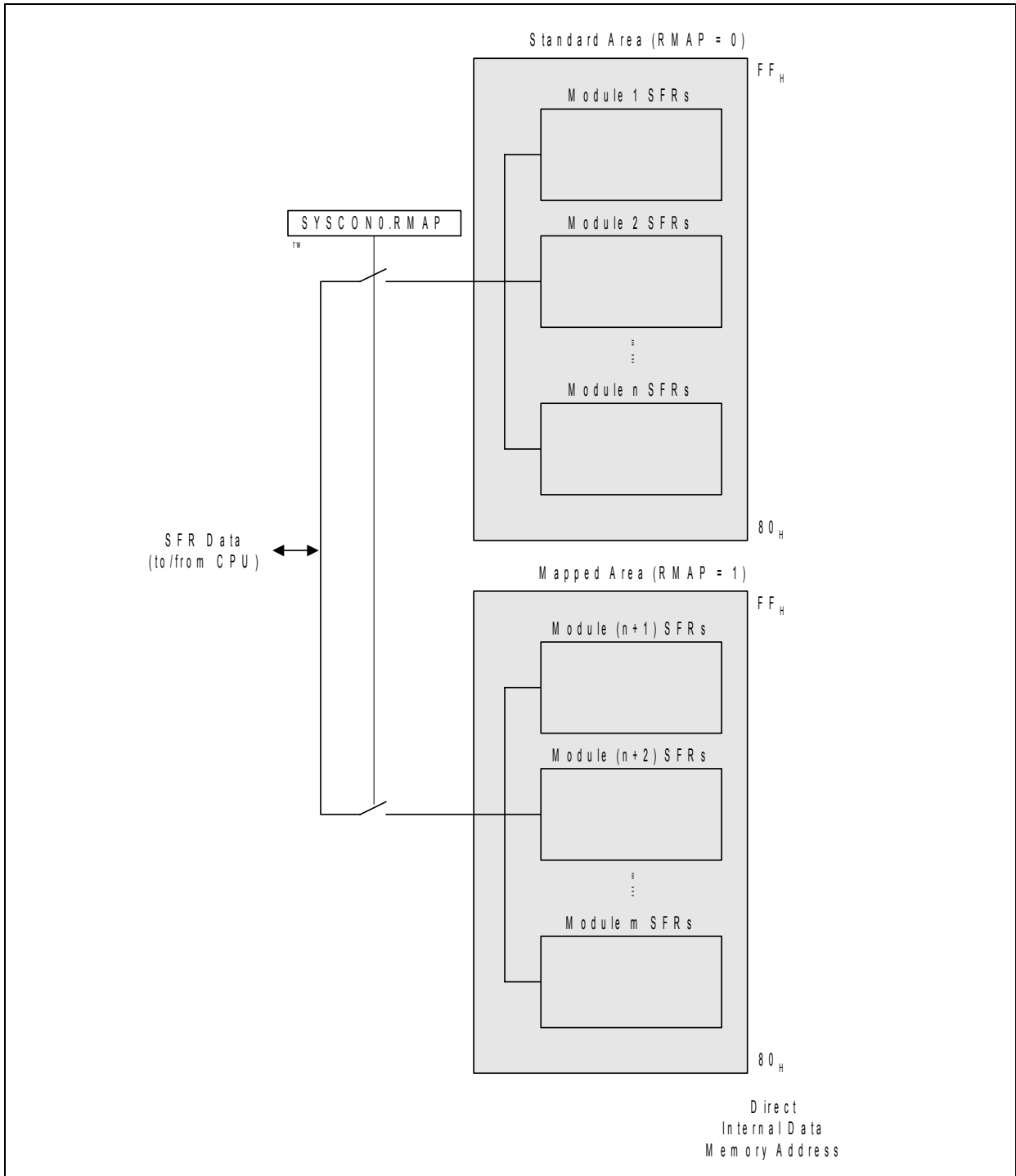

Figure 3-3 Address Extension by Mapping

3.3.2 Address Extension by Paging

Address extension is further performed at the module level by paging. With the address extension by mapping, the XC866 has a 256-SFR address range. However, this is still less than the total number of SFRs needed by the on-chip peripherals. To meet this requirement, some peripherals have a built-in local address extension mechanism for increasing the number of addressable SFRs. The extended address range is not directly controlled by the CPU instruction itself, but is derived from bit field PAGE in the module page register MOD_PAGE. Hence, the bit field PAGE must be programmed before accessing the SFR of the target module. Each module may contain a different number of pages and a different number of SFRs per page, depending on the specific requirement. Besides setting the correct RMAP bit value to select the SFR area, the user must also ensure that a valid PAGE is selected to target the desired SFR. A page inside the extended address range can be selected as shown in [Figure 3-4](#).

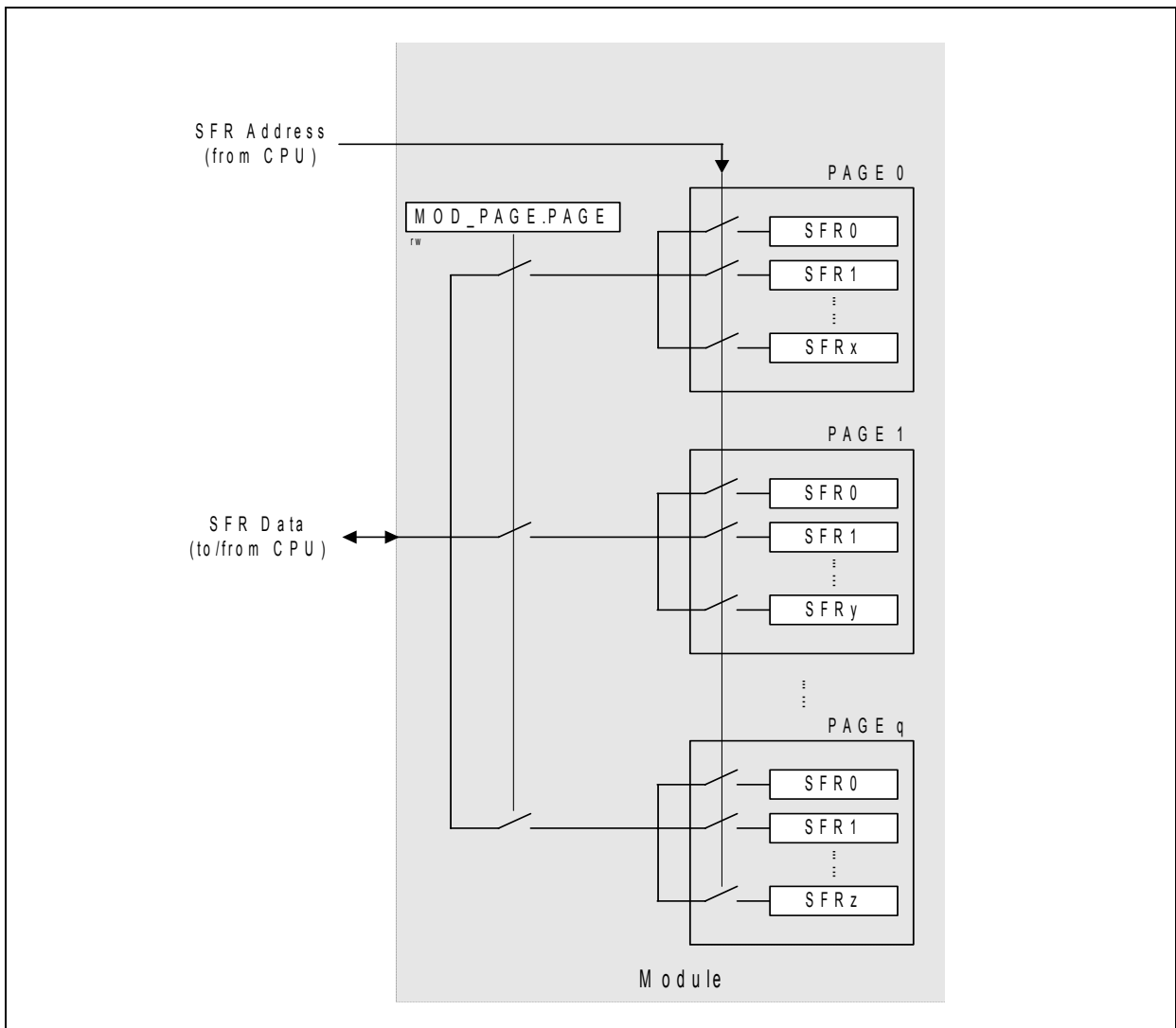

Figure 3-4 Address Extension by Paging

Memory Organization

In order to access a register located in a page different from the actual one, the current page must be left. This is done by reprogramming the bit field PAGE in the page register. Only then can the desired access be performed.

If an interrupt routine is initiated between the page register access and the module register access, and the interrupt needs to access a register located in another page, the current page setting can be saved, the new one programmed and finally, the old page setting restored. This is possible with the storage fields STx (x = 0 - 3) for the save and restore action of the current page setting. By indicating which storage bit field should be used in parallel with the new page value, a single write operation can:

- Save the contents of PAGE in STx before overwriting with the new value (this is done in the beginning of the interrupt routine to save the current page setting and program the new page number); or
- Overwrite the contents of PAGE with the contents of STx, ignoring the value written to the bit positions of PAGE (this is done at the end of the interrupt routine to restore the previous page setting before the interrupt occurred)

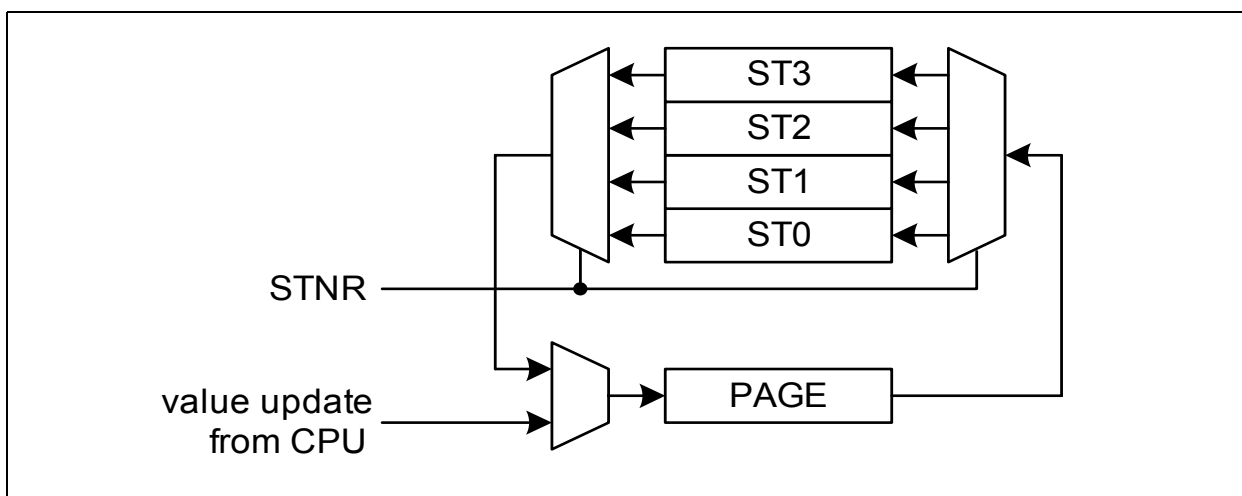

Figure 3-5 Storage Elements for Paging

With this mechanism, a certain number of interrupt routines (or other routines) can perform page changes without reading and storing the previously used page information. The use of only write operations makes the system simpler and faster. Consequently, this mechanism significantly improves the performance of short interrupt routines.

The XC866 supports local address extension for:

- Parallel Ports
- Analog-to-Digital Converter (ADC)
- Capture/Compare Unit 6 (CCU6)
- System Control Registers

Memory Organization

The page register has the following definition:

MOD_PAGE

Page Register for module MOD

Reset Value: 00_H

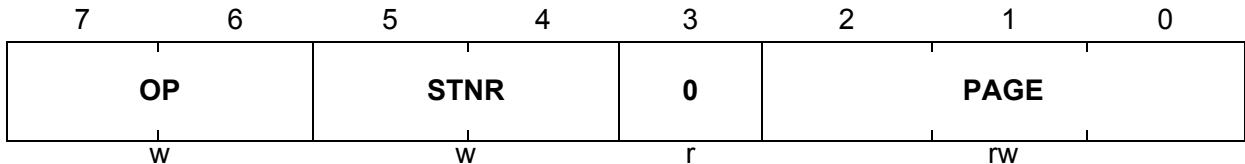

Field	Bits	Type	Description
PAGE	[2:0]	rw	<p>Page Bits When written, the value indicates the new page. When read, the value indicates the currently active page.</p>
STNR	[5:4]	w	<p>Storage Number This number indicates which storage bit field is the target of the operation defined by bit field OP. If OP = 10_B, the contents of PAGE are saved in STx before being overwritten with the new value. If OP = 11_B, the contents of PAGE are overwritten by the contents of STx. The value written to the bit positions of PAGE is ignored.</p> <p>00 ST0 is selected. 01 ST1 is selected. 10 ST2 is selected. 11 ST3 is selected.</p>

Memory Organization

Field	Bits	Type	Description
OP	[7:6]	w	Operation 0X Manual page mode. The value of STNR is ignored and PAGE is directly written. 10 New page programming with automatic page saving. The value written to the bit positions of PAGE is stored. In parallel, the previous contents of PAGE are saved in the storage bit field STx indicated by STNR. 11 Automatic restore page action. The value written to the bit positions PAGE is ignored and instead, PAGE is overwritten by the contents of the storage bit field STx indicated by STNR.
0	3	r	Reserved Returns 0 if read; should be written with 0.

3.3.3 Bit-Addressing

SFRs that have addresses in the form of 1XXXX000_B (e.g., 80_H, 88_H, 90_H, ..., F0_H, F8_H) are bitaddressable. The addresses of these bitaddressable SFRs appear in bold typeface in [Table 3-1](#) to [Table 3-9](#).

3.3.4 System Control Registers

The system control SFRs are used to control the overall system functionalities, such as interrupts, variable baud rate generation, clock management, bit protection scheme, oscillator and PLL control. The SFRs are located in the standard memory area (RMAP = 0) and organized into 2 pages. The SCU_PAGE register is located at B2_H. It contains the page value and page control information.

SCU_PAGE

Page Register for System Control

Reset Value: 00_H

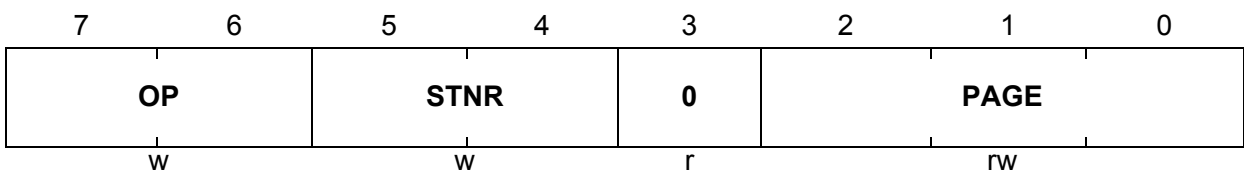

Field	Bits	Type	Description
PAGE	[2:0]	rw	<p>Page Bits When written, the value indicates the new page. When read, the value indicates the currently active page.</p>
STNR	[5:4]	w	<p>Storage Number This number indicates which storage bit field is the target of the operation defined by bit field OP. If OP = 10_B, the contents of PAGE are saved in STx before being overwritten with the new value. If OP = 11_B, the contents of PAGE are overwritten by the contents of STx. The value written to the bit positions of PAGE is ignored.</p> <p>00 ST0 is selected. 01 ST1 is selected. 10 ST2 is selected. 11 ST3 is selected.</p>

Memory Organization

Field	Bits	Type	Description
OP	[7:6]	w	<p>Operation</p> <p>0X Manual page mode. The value of STNR is ignored and PAGE is directly written.</p> <p>10 New page programming with automatic page saving. The value written to the bit positions of PAGE is stored. In parallel, the previous contents of PAGE are saved in the storage bit field STx indicated by STNR.</p> <p>11 Automatic restore page action. The value written to the bit positions PAGE is ignored and instead, PAGE is overwritten by the contents of the storage bit field STx indicated by STNR.</p>
0	3	r	<p>Reserved</p> <p>Returns 0 if read; should be written with 0.</p>

Memory Organization

3.3.4.1 Bit Protection Scheme

The bit protection scheme prevents direct software writing of selected bits (i.e., protected bits) using the PASSWD register. When the bit field MODE is 11_B, writing 10011_B to the bit field PASS opens access to writing of all protected bits, and writing 10101_B to the bit field PASS closes access to writing of all protected bits. Note that access is opened for maximum 32 CCLKs if the “close access” password is not written. If “open access” password is written again before the end of 32 CCLK cycles, there will be a recount of 32 CCLK cycles. The protected bits include NDIV, WDTEN, PD, and SD.

PASSWD

Password Register

Reset Value: 07_H

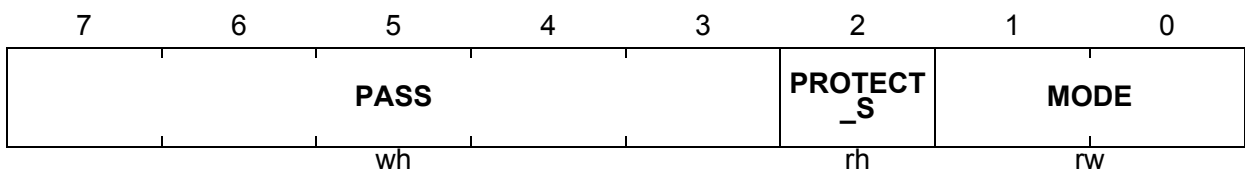

Field	Bits	Type	Description
MODE	[1:0]	rw	Bit Protection Scheme Control bits 00 Scheme Disabled 11 Scheme Enabled (default) Others: Scheme Enabled These two bits cannot be written directly. To change the value between 11 _B and 00 _B , the bit field PASS must be written with 11000 _B ; only then, will the MODE[1:0] be registered.
PROTECT_S	2	rh	Bit Protection Signal Status bit This bit shows the status of the protection. 0 Software is able to write to all protected bits. 1 Software is unable to write to any protected bits.
PASS	[7:3]	wh	Password bits The Bit Protection Scheme only recognizes three patterns. 11000 _B Enables writing of the bit field MODE. 10011 _B Opens access to writing of all protected bits. 10101 _B Closes access to writing of all protected bits.

3.3.5 XC866 Register Overview

The SFRs of the XC866 are organized into groups according to their functional units. The contents (bits) of the SFRs are summarized in [Section 3.3.5.1](#) to [Section 3.3.5.9](#).

Note: The addresses of the bitaddressable SFRs appear in bold typeface in [Table 3-1](#) to [Table 3-9](#).

3.3.5.1 CPU Registers

The CPU SFRs can be accessed in both the standard and mapped memory areas (RMAP = 0 or 1).

Table 3-1 CPU Register Overview

Addr	Register Name	Bit	7	6	5	4	3	2	1	0
RMAP = 0 or 1										
81 _H	SP Stack Pointer Register Reset: 07_H	Bit Field	SP							
		Type	rw							
82 _H	DPL Data Pointer Register Low Reset: 00_H	Bit Field	DPL7	DPL6	DPL5	DPL4	DPL3	DPL2	DPL1	DPL0
		Type	rw	rw	rw	rw	rw	rw	rw	rw
83 _H	DPH Data Pointer Register High Reset: 00_H	Bit Field	DPH7	DPH6	DPH5	DPH4	DPH3	DPH2	DPH1	DPH0
		Type	rw	rw	rw	rw	rw	rw	rw	rw
87 _H	PCON Power Control Register Reset: 00_H	Bit Field	SMOD	0			GF1	GF0	0	IDLE
		Type	rw	r			rw	rw	r	rw
88 _H	TCON Timer Control Register Reset: 00_H	Bit Field	TF1	TR1	TF0	TR0	IE1	IT1	IE0	IT0
		Type	rwh	rw	rwh	rw	rwh	rw	rwh	rw
89 _H	TMOD Timer Mode Register Reset: 00_H	Bit Field	GATE1	0	T1M		GATE0	0	T0M	
		Type	rw	r	rw		rw	r	rw	
8A _H	TL0 Timer 0 Register Low Reset: 00_H	Bit Field	VAL							
		Type	rwh							
8B _H	TL1 Timer 1 Register Low Reset: 00_H	Bit Field	VAL							
		Type	rwh							
8C _H	TH0 Timer 0 Register High Reset: 00_H	Bit Field	VAL							
		Type	rwh							
8D _H	TH1 Timer 1 Register High Reset: 00_H	Bit Field	VAL							
		Type	rwh							
98 _H	SCON Serial Channel Control Register Reset: 00_H	Bit Field	SM0	SM1	SM2	REN	TB8	RB8	TI	RI
		Type	rw	rw	rw	rw	rw	rwh	rwh	rwh
99 _H	SBUF Serial Data Buffer Register Reset: 00_H	Bit Field	VAL							
		Type	rwh							
A2 _H	EO Extended Operation Register Reset: 00_H	Bit Field	0			TRAP_EN	0			DPSEL0
		Type	r			rw	r			rw
A8 _H	IEN0 Interrupt Enable Register 0 Reset: 00_H	Bit Field	EA	0	ET2	ES	ET1	EX1	ET0	EX0
		Type	rw	r	rw	rw	rw	rw	rw	rw
B8 _H	IP Interrupt Priority Register Reset: 00_H	Bit Field	0		PT2	PS	PT1	PX1	PT0	PX0
		Type	r		rw	rw	rw	rw	rw	rw
B9 _H	IPH Interrupt Priority Register High Reset: 00_H	Bit Field	0		PT2H	PSH	PT1H	PX1H	PT0H	PX0H
		Type	r		rw	rw	rw	rw	rw	rw
D0 _H	PSW Program Status Word Register Reset: 00_H	Bit Field	CY	AC	F0	RS1	RS0	OV	F1	P
		Type	rw	rwh	rwh	rw	rw	rwh	rwh	rh

Memory Organization
Table 3-1 CPU Register Overview (cont'd)

Addr	Register Name	Reset:	Bit	7	6	5	4	3	2	1	0
E0 _H	ACC Accumulator Register	00_H	Bit Field	ACC7	ACC6	ACC5	ACC4	ACC3	ACC2	ACC1	ACC0
			Type	rw	rw	rw	rw	rw	rw	rw	rw
E8 _H	IEN1 Interrupt Enable Register 1	00_H	Bit Field	ECCIP 3	ECCIP 2	ECCIP 1	ECCIP 0	EXM	EX2	ESSC	EADC
			Type	rw	rw	rw	rw	rw	rw	rw	rw
F0 _H	B B Register	00_H	Bit Field	B7	B6	B5	B4	B3	B2	B1	B0
			Type	rw	rw	rw	rw	rw	rw	rw	rw
F8 _H	IP1 Interrupt Priority Register 1	00_H	Bit Field	PCCIP 3	PCCIP 2	PCCIP 1	PCCIP 0	PXM	PX2	PSSC	PADC
			Type	rw	rw	rw	rw	rw	rw	rw	rw
F9 _H	IPH1 Interrupt Priority Register 1 High	00_H	Bit Field	PCCIP 3H	PCCIP 2H	PCCIP 1H	PCCIP 0H	PXMH	PX2H	PSSCH	PADCH
			Type	rw	rw	rw	rw	rw	rw	rw	rw

3.3.5.2 System Control Registers

The system control SFRs can be accessed in the standard memory area (RMAP = 0).

Table 3-2 System Control Register Overview

Addr	Register Name	Reset:	Bit	7	6	5	4	3	2	1	0
RMAP = 0 or 1											
8F _H	SYSCON0 System Control Register 0	00_H	Bit Field	0							RMAP
			Type	r							rw
RMAP = 0											
BF _H	SCU_PAGE Page Register for System Control	00_H	Bit Field	OP		STNR		0	PAGE		
			Type	w		w		r	rw		
RMAP = 0, Page 0											
B3 _H	MODPISSEL Peripheral Input Select Register	00_H	Bit Field	0		JTAG TDIS	JTAG TCKS	0		EXINT OIS	URRIS
			Type	r		rw	rw	r		rw	rw
B4 _H	IRCON0 Interrupt Request Register 0	00_H	Bit Field	0	EXINT 6	EXINT 5	EXINT 4	EXINT 3	EXINT 2	EXINT 1	EXINT 0
			Type	r	rwh	rwh	rwh	rwh	rwh	rwh	rwh
B5 _H	IRCON1 Interrupt Request Register 1	00_H	Bit Field	0			ADCS RC1	ADCS RC0	RIR	TIR	EIR
			Type	r			rwh	rwh	rwh	rwh	rwh
B7 _H	EXICON0 External Interrupt Control Register 0	00_H	Bit Field	EXINT3		EXINT2		EXINT1		EXINT0	
			Type	rw		rw		rw		rw	
BA _H	EXICON1 External Interrupt Control Register 1	00_H	Bit Field	0		EXINT6		EXINT5		EXINT4	
			Type	r		rw		rw		rw	
BB _H	NMICON NMI Control Register	00_H	Bit Field	0	NMI ECC	NMI VDDP	NMI VDD	NMI OCDS	NMI FLASH TIMER	NMI PLL	NMI WDT
			Type	r	rw	rw	rw	rw	rw	rw	
BC _H	NMISR NMI Status Register	00_H	Bit Field	0	FNMI ECC	FNMI VDDP	FNMI VDD	FNMI OCDS	FNMI FLASH TIMER	FNMI PLL	FNMI WDT
			Type	r	rwh	rwh	rwh	rwh	rwh	rwh	
BD _H	BCON Baud Rate Control Register	00_H	Bit Field	BGSEL		T2EXIS	BREN	BRPRE			R
			Type	rw		rw	rw	rw			rw
BE _H	BG Baud Rate Timer/Reload Register	00_H	Bit Field	BR_VALUE							
			Type	rw							

Memory Organization
Table 3-2 System Control Register Overview (cont'd)

Addr	Register Name	Bit	7	6	5	4	3	2	1	0	
RMAP = 0, Page 1											
B3 _H	ID Identity Register Reset: 01_H	Bit Field	PRODIG				VERID				
		Type	r				r				
B4 _H	PMCON0 Power Mode Control Register 0 Reset: 00_H	Bit Field	0	WDT RST	WKRS	WK SEL	SD	PD	WS		
		Type	r	rwh	rwh	rw	rw	rwh	rw		
B5 _H	PMCON1 Power Mode Control Register 1 Reset: 00_H	Bit Field	0				T2_DIS	CCU _DIS	SSC _DIS	ADC _DIS	
		Type	r				rw	rw	rw	rw	
B6 _H	OSC_CON OSC Control Register Reset: 08_H	Bit Field	0			OSC PD	XPD	OSC SS	ORD RES	OSCR	
		Type	r			rw	rw	rw	rwh	rw	
B7 _H	PLL_CON PLL Control Register Reset: 20_H	Bit Field	NDIV				VCO BYP	OSC DISC	RESLD	LOCK	
		Type	rw				rw	rw	rwh	rh	
BA _H	CMCON Clock Control Register Reset: 00_H	Bit Field	0				CLKREL				
		Type	r				rw				
BB _H	PASSWD Password Register Reset: 07_H	Bit Field	PASS					PROTE CT_S	MODE		
		Type	wh					rh	rw		
BC _H	FEAL Flash Error Address Register Low Reset: 00_H	Bit Field	ECCERRADDR[7:0]								
		Type	rh								
BD _H	FEAH Flash Error Address Register High Reset: 00_H	Bit Field	ECCERRADDR[15:8]								
		Type	rh								

3.3.5.3 WDT Registers

The WDT SFRs can be accessed in the mapped memory area (RMAP = 1).

Table 3-3 WDT Register Overview

Addr	Register Name	Bit	7	6	5	4	3	2	1	0
RMAP = 1										
BB _H	WDTCON Watchdog Timer Control Register Reset: 00 _H	Bit Field	0	WINB EN	WDT PR	0	WDT EN	WDT RS	WDT IN	
		Type	r	rw	rh	r	rw	rwh	rw	
BC _H	WDTREL Watchdog Timer Reload Register Reset: 00 _H	Bit Field	WDTREL							
		Type	rw							
BD _H	WDTWINB Watchdog Window-Boundary Count Register Reset: 00 _H	Bit Field	WDTWINB							
		Type	rw							
BE _H	WDTL Watchdog Timer Register Low Reset: 00 _H	Bit Field	WDT[7:0]							
		Type	rh							
BF _H	WDTH Watchdog Timer Register High Reset: 00 _H	Bit Field	WDT[15:8]							
		Type	rh							

3.3.5.4 Port Registers

The Port SFRs can be accessed in the standard memory area (RMAP = 0).

Table 3-4 Port Register Overview

Addr	Register Name	Bit	7	6	5	4	3	2	1	0
RMAP = 0										
B2 _H	PORT_PAGE Page Register for PORT Reset: 00 _H	Bit Field	OP	STNR	0	PAGE				
		Type	w	w	r	rw				
RMAP = 0, Page 0										
80 _H	P0_DATA P0 Data Register Reset: 00 _H	Bit Field	0	P5	P4	P3	P2	P1	P0	
		Type	r	rw	rw	rw	rw	rw	rw	rw
86 _H	P0_DIR P0 Direction Register Reset: 00 _H	Bit Field	0	P5	P4	P3	P2	P1	P0	
		Type	r	rw	rw	rw	rw	rw	rw	rw
90 _H	P1_DATA P1 Data Register Reset: 00 _H	Bit Field	P7	P6	P5	0		P1	P0	
		Type	rw	rw	rw	r		rw	rw	
91 _H	P1_DIR P1 Direction Register Reset: 00 _H	Bit Field	P7	P6	P5	0		P1	P0	
		Type	rw	rw	rw	r		rw	rw	
A0 _H	P2_DATA P2 Data Register Reset: 00 _H	Bit Field	P7	P6	P5	P4	P3	P2	P1	P0
		Type	rw	rw	rw	rw	rw	rw	rw	rw
B0 _H	P3_DATA P3 Data Register Reset: 00 _H	Bit Field	P7	P6	P5	P4	P3	P2	P1	P0
		Type	rw	rw	rw	rw	rw	rw	rw	rw
B1 _H	P3_DIR P3 Direction Register Reset: 00 _H	Bit Field	P7	P6	P5	P4	P3	P2	P1	P0
		Type	rw	rw	rw	rw	rw	rw	rw	rw
RMAP = 0, Page 1										
80 _H	P0_PUDSEL P0 Pull-Up/Pull-Down Select Register Reset: FF _H	Bit Field	0	P5	P4	P3	P2	P1	P0	
		Type	r	rw	rw	rw	rw	rw	rw	rw
86 _H	P0_PUDEN P0 Pull-Up/Pull-Down Enable Register Reset: C4 _H	Bit Field	0	P5	P4	P3	P2	P1	P0	
		Type	r	rw	rw	rw	rw	rw	rw	rw
90 _H	P1_PUDSEL P1 Pull-Up/Pull-Down Select Register Reset: FF _H	Bit Field	P7	P6	P5	0		P1	P0	
		Type	rw	rw	rw	r		rw	rw	

Memory Organization
Table 3-4 Port Register Overview (cont'd)

Addr	Register Name	Bit	7	6	5	4	3	2	1	0
91 _H	P1_PU DEN P1 Pull-Up/Pull-Down Enable Register Reset: FF _H	Bit Field	P7	P6	P5	0			P1	P0
		Type	rw	rw	rw	r			rw	rw
A0 _H	P2_PU DSEL P2 Pull-Up/Pull-Down Select Register Reset: FF _H	Bit Field	P7	P6	P5	P4	P3	P2	P1	P0
		Type	rw	rw	rw	rw	rw	rw	rw	rw
A1 _H	P2_PU DEN P2 Pull-Up/Pull-Down Enable Register Reset: 00 _H	Bit Field	P7	P6	P5	P4	P3	P2	P1	P0
		Type	rw	rw	rw	rw	rw	rw	rw	rw
B0 _H	P3_PU DSEL P3 Pull-Up/Pull-Down Select Register Reset: BF _H	Bit Field	P7	P6	P5	P4	P3	P2	P1	P0
		Type	rw	rw	rw	rw	rw	rw	rw	rw
B1 _H	P3_PU DEN P3 Pull-Up/Pull-Down Enable Register Reset: 40 _H	Bit Field	P7	P6	P5	P4	P3	P2	P1	P0
		Type	rw	rw	rw	rw	rw	rw	rw	rw
RMAP = 0, Page 2										
80 _H	P0_ALTSEL0 P0 Alternate Select 0 Register Reset: 00 _H	Bit Field	0		P5	P4	P3	P2	P1	P0
		Type	r		rw	rw	rw	rw	rw	rw
86 _H	P0_ALTSEL1 P0 Alternate Select 1 Register Reset: 00 _H	Bit Field	0		P5	P4	P3	P2	P1	P0
		Type	r		rw	rw	rw	rw	rw	rw
90 _H	P1_ALTSEL0 P1 Alternate Select 0 Register Reset: 00 _H	Bit Field	P7	P6	P5	0			P1	P0
		Type	rw	rw	rw	r			rw	rw
91 _H	P1_ALTSEL1 P1 Alternate Select 1 Register Reset: 00 _H	Bit Field	P7	P6	P5	0			P1	P0
		Type	rw	rw	rw	r			rw	rw
B0 _H	P3_ALTSEL0 P3 Alternate Select 0 Register Reset: 00 _H	Bit Field	P7	P6	P5	P4	P3	P2	P1	P0
		Type	rw	rw	rw	rw	rw	rw	rw	rw
B1 _H	P3_ALTSEL1 P3 Alternate Select 1 Register Reset: 00 _H	Bit Field	P7	P6	P5	P4	P3	P2	P1	P0
		Type	rw	rw	rw	rw	rw	rw	rw	rw
RMAP = 0, Page 3										
80 _H	P0_OD P0 Open Drain Control Register Reset: 00 _H	Bit Field	0		P5	P4	P3	P2	P1	P0
		Type	r		rw	rw	rw	rw	rw	rw
90 _H	P1_OD P1 Open Drain Control Register Reset: 00 _H	Bit Field	P7	P6	P5	0			P1	P0
		Type	rw	rw	rw	r			rw	rw
B0 _H	P3_OD P3 Open Drain Control Register Reset: 00 _H	Bit Field	P7	P6	P5	P4	P3	P2	P1	P0
		Type	rw	rw	rw	rw	rw	rw	rw	rw

3.3.5.5 ADC Registers

The ADC SFRs can be accessed in the standard memory area (RMAP = 0).

Table 3-5 ADC Register Overview

Addr	Register Name	Bit	7	6	5	4	3	2	1	0
RMAP = 0										
D1 _H	ADC_PAGE Page Register for ADC Reset: 00 _H	Bit Field	OP		STNR		0	PAGE		
		Type	w		w		r	rw		
RMAP = 0, Page 0										
CA _H	ADC_GLOBCTR Global Control Register Reset: 00 _H	Bit Field	ANON	DW	CTC		0			
		Type	rw	rw	rw		r			
CB _H	ADC_GLOBSTR Global Status Register Reset: 00 _H	Bit Field	0		CHNR			0	SAM PLE	BUSY
		Type	r		rh			r	rh	rh
CC _H	ADC_PRAR Priority and Arbitration Register Reset: 00 _H	Bit Field	ASEN1	ASEN0	0	ARBM	CSM1	PRI01	CSM0	PRI00
		Type	rw	rw	r	rw	rw	rw	rw	rw
CD _H	ADC_LCBR Limit Check Boundary Register Reset: B7 _H	Bit Field	BOUND1				BOUND0			
		Type	rw				rw			

Memory Organization
Table 3-5 ADC Register Overview (cont'd)

Addr	Register Name	Reset	Bit	7	6	5	4	3	2	1	0	
CE _H	ADC_INPCR0 Input Class Register 0	Reset: 00 _H	Bit Field	STC								
			Type	rw								
CF _H	ADC_ETRCR External Trigger Control Register	Reset: 00 _H	Bit Field	SYNEN 1	SYNEN 0	ETRSEL1			ETRSEL0			
			Type	rw	rw	rw			rw			
RMAP = 0, Page 1												
CA _H	ADC_CHCTR0 Channel Control Register 0	Reset: 00 _H	Bit Field	0	LCC			0	RESRSEL			
			Type	r	rw			r	rw			
CB _H	ADC_CHCTR1 Channel Control Register 1	Reset: 00 _H	Bit Field	0	LCC			0	RESRSEL			
			Type	r	rw			r	rw			
CC _H	ADC_CHCTR2 Channel Control Register 2	Reset: 00 _H	Bit Field	0	LCC			0	RESRSEL			
			Type	r	rw			r	rw			
CD _H	ADC_CHCTR3 Channel Control Register 3	Reset: 00 _H	Bit Field	0	LCC			0	RESRSEL			
			Type	r	rw			r	rw			
CE _H	ADC_CHCTR4 Channel Control Register 4	Reset: 00 _H	Bit Field	0	LCC			0	RESRSEL			
			Type	r	rw			r	rw			
CF _H	ADC_CHCTR5 Channel Control Register 5	Reset: 00 _H	Bit Field	0	LCC			0	RESRSEL			
			Type	r	rw			r	rw			
D2 _H	ADC_CHCTR6 Channel Control Register 6	Reset: 00 _H	Bit Field	0	LCC			0	RESRSEL			
			Type	r	rw			r	rw			
D3 _H	ADC_CHCTR7 Channel Control Register 7	Reset: 00 _H	Bit Field	0	LCC			0	RESRSEL			
			Type	r	rw			r	rw			
RMAP = 0, Page 2												
CA _H	ADC_RESR0L Result Register 0 Low	Reset: 00 _H	Bit Field	RESULT[1:0]	0	VF	DRC	CHNR				
			Type	rh	r	rh	rh	rh				
CB _H	ADC_RESR0H Result Register 0 High	Reset: 00 _H	Bit Field	RESULT[9:2]								
			Type	rh								
CC _H	ADC_RESR1L Result Register 1 Low	Reset: 00 _H	Bit Field	RESULT[1:0]	0	VF	DRC	CHNR				
			Type	rh	r	rh	rh	rh				
CD _H	ADC_RESR1H Result Register 1 High	Reset: 00 _H	Bit Field	RESULT[9:2]								
			Type	rh								
CE _H	ADC_RESR2L Result Register 2 Low	Reset: 00 _H	Bit Field	RESULT[1:0]	0	VF	DRC	CHNR				
			Type	rh	r	rh	rh	rh				
CF _H	ADC_RESR2H Result Register 2 High	Reset: 00 _H	Bit Field	RESULT[9:2]								
			Type	rh								
D2 _H	ADC_RESR3L Result Register 3 Low	Reset: 00 _H	Bit Field	RESULT[1:0]	0	VF	DRC	CHNR				
			Type	rh	r	rh	rh	rh				
D3 _H	ADC_RESR3H Result Register 3 High	Reset: 00 _H	Bit Field	RESULT[9:2]								
			Type	rh								
RMAP = 0, Page 3												
CA _H	ADC_RESRA0L Result Register 0, View A Low	Reset: 00 _H	Bit Field	RESULT[2:0]			VF	DRC	CHNR			
			Type	rh			rh	rh	rh			
CB _H	ADC_RESRA0H Result Register 0, View A High	Reset: 00 _H	Bit Field	RESULT[10:3]								
			Type	rh								
CC _H	ADC_RESRA1L Result Register 1, View A Low	Reset: 00 _H	Bit Field	RESULT[2:0]			VF	DRC	CHNR			
			Type	rh			rh	rh	rh			
CD _H	ADC_RESRA1H Result Register 1, View A High	Reset: 00 _H	Bit Field	RESULT[10:3]								
			Type	rh								
CE _H	ADC_RESRA2L Result Register 2, View A Low	Reset: 00 _H	Bit Field	RESULT[2:0]			VF	DRC	CHNR			
			Type	rh			rh	rh	rh			

Memory Organization
Table 3-5 ADC Register Overview (cont'd)

Addr	Register Name	Bit	7	6	5	4	3	2	1	0
CF _H	ADC_RESRA2H Reset: 00 _H Result Register 2, View A High	Bit Field	RESULT[10:3]							
		Type	rh							
D2 _H	ADC_RESRA3L Reset: 00 _H Result Register 3, View A Low	Bit Field	RESULT[2:0]			VF	DRC	CHNR		
		Type	rh			rh	rh	rh		
D3 _H	ADC_RESRA3H Reset: 00 _H Result Register 3, View A High	Bit Field	RESULT[10:3]							
		Type	rh							
RMAP = 0, Page 4										
CA _H	ADC_RCR0 Reset: 00 _H Result Control Register 0	Bit Field	VFCTR	WFR	FEN	IEN	0			DRCT R
		Type	rw	rw	rw	rw	r			rw
CB _H	ADC_RCR1 Reset: 00 _H Result Control Register 1	Bit Field	VFCTR	WFR	FEN	IEN	0			DRCT R
		Type	rw	rw	rw	rw	r			rw
CC _H	ADC_RCR2 Reset: 00 _H Result Control Register 2	Bit Field	VFCTR	WFR	FEN	IEN	0			DRCT R
		Type	rw	rw	rw	rw	r			rw
CD _H	ADC_RCR3 Reset: 00 _H Result Control Register 3	Bit Field	VFCTR	WFR	FEN	IEN	0			DRCT R
		Type	rw	rw	rw	rw	r			rw
CE _H	ADC_VFCR Reset: 00 _H Valid Flag Clear Register	Bit Field	0				VFC3	VFC2	VFC1	VFC0
		Type	r				w	w	w	w
RMAP = 0, Page 5										
CA _H	ADC_CHINFR Reset: 00 _H Channel Interrupt Flag Register	Bit Field	CHINF 7	CHINF 6	CHINF 5	CHINF 4	CHINF 3	CHINF 2	CHINF 1	CHINF 0
		Type	rh	rh	rh	rh	rh	rh	rh	rh
CB _H	ADC_CHINCR Reset: 00 _H Channel Interrupt Clear Register	Bit Field	CHINC 7	CHINC 6	CHINC 5	CHINC 4	CHINC 3	CHINC 2	CHINC 1	CHINC 0
		Type	w	w	w	w	w	w	w	w
CC _H	ADC_CHINSR Reset: 00 _H Channel Interrupt Set Register	Bit Field	CHINS 7	CHINS 6	CHINS 5	CHINS 4	CHINS 3	CHINS 2	CHINS 1	CHINS 0
		Type	w	w	w	w	w	w	w	w
CD _H	ADC_CHINPR Reset: 00 _H Channel Interrupt Node Pointer Register	Bit Field	CHINP 7	CHINP 6	CHINP 5	CHINP 4	CHINP 3	CHINP 2	CHINP 1	CHINP 0
		Type	rw	rw	rw	rw	rw	rw	rw	rw
CE _H	ADC_EVINFR Reset: 00 _H Event Interrupt Flag Register	Bit Field	EVINF 7	EVINF 6	EVINF 5	EVINF 4	0		EVINF 1	EVINF 0
		Type	rh	rh	rh	rh	r		rh	rh
CF _H	ADC_EVINCR Reset: 00 _H Event Interrupt Clear Flag Register	Bit Field	EVINC 7	EVINC 6	EVINC 5	EVINC 4	0		EVINC 1	EVINC 0
		Type	w	w	w	w	r		w	w
D2 _H	ADC_EVINSR Reset: 00 _H Event Interrupt Set Flag Register	Bit Field	EVINS 7	EVINS 6	EVINS 5	EVINS 4	0		EVINS 1	EVINS 0
		Type	w	w	w	w	r		w	w
D3 _H	ADC_EVINPR Reset: 00 _H Event Interrupt Node Pointer Register	Bit Field	EVINP 7	EVINP 6	EVINP 5	EVINP 4	0		EVINP 1	EVINP 0
		Type	rw	rw	rw	rw	r		rw	rw
RMAP = 0, Page 6										
CA _H	ADC_CRGR1 Reset: 00 _H Conversion Request Control Register 1	Bit Field	CH7	CH6	CH5	CH4	0			
		Type	rwh	rwh	rwh	rwh	r			
CB _H	ADC_CRPR1 Reset: 00 _H Conversion Request Pending Register 1	Bit Field	CHP7	CHP6	CHP5	CHP4	0			
		Type	rwh	rwh	rwh	rwh	r			

Memory Organization
Table 3-5 ADC Register Overview (cont'd)

Addr	Register Name	Bit	7	6	5	4	3	2	1	0
CC _H	ADC_CRMR1 Reset: 00 _H Conversion Request Mode Register 1	Bit Field	0	LDEV	CLR PND	SCAN	ENSI	ENTR	ENGT	
		Type	r	w	w	rw	rw	rw	rw	
CD _H	ADC_QMR0 Reset: 00 _H Queue Mode Register 0	Bit Field	CEV	TREV	FLUSH	CLR _V	TRMD	ENTR	ENGT	
		Type	w	w	w	w	rw	rw	rw	
CE _H	ADC_QSR0 Reset: 20 _H Queue Status Register 0	Bit Field	0		EMPTY	EV	0			
		Type	r		rh	rh	r			
CF _H	ADC_Q0R0 Reset: 00 _H Queue 0 Register 0	Bit Field	EXTR	ENSI	RF	V	0	REQCHNR		
		Type	rh	rh	rh	rh	r	rh		
D2 _H	ADC_QBUR0 Reset: 00 _H Queue Backup Register 0	Bit Field	EXTR	ENSI	RF	V	0	REQCHNR		
		Type	rh	rh	rh	rh	r	rh		
D2 _H	ADC_QINR0 Reset: 00 _H Queue Input Register 0	Bit Field	EXTR	ENSI	RF	0		REQCHNR		
		Type	w	w	w	r		w		

3.3.5.6 Timer 2 Registers

The Timer 2 SFRs can be accessed in the standard memory area (RMAP = 0).

Table 3-6 Timer 2 Register Overview

Addr	Register Name	Bit	7	6	5	4	3	2	1	0
C0 _H	T2_T2CON Reset: 00 _H Timer 2 Control Register	Bit Field	TF2	EXF2	0		EXEN2	TR2	C/T2	CP/ RL2
		Type	rwh	rwh	r		rw	rwh	rw	rw
C1 _H	T2_T2MOD Reset: 00 _H Timer 2 Mode Register	Bit Field	0		EDGE SEL	PREN	T2PRE		DCEN	
		Type	r		rw	rw	rw		rw	
C2 _H	T2_RC2L Reset: 00 _H Timer 2 Reload/Capture Register Low	Bit Field	RC2[7:0]							
		Type	rwh							
C3 _H	T2_RC2H Reset: 00 _H Timer 2 Reload/Capture Register High	Bit Field	RC2[15:8]							
		Type	rwh							
C4 _H	T2_T2L Reset: 00 _H Timer 2 Register Low	Bit Field	THL2[7:0]							
		Type	rwh							
C5 _H	T2_T2H Reset: 00 _H Timer 2 Register High	Bit Field	THL2[15:8]							
		Type	rwh							

3.3.5.7 CCU6 Registers

The CCU6 SFRs can be accessed in the standard memory area (RMAP = 0).

Table 3-7 CCU6 Register Overview

Addr	Register Name	Bit	7	6	5	4	3	2	1	0
RMAP = 0										
A3 _H	CCU6_PAGE Reset: 00 _H Page Register for CCU6	Bit Field	OP		STNR		0	PAGE		
		Type	w		w		r	rw		
RMAP = 0, Page 0										
9A _H	CCU6_CC63SRL Reset: 00 _H Capture/Compare Shadow Register for Channel CC63 Low	Bit Field	CC63SL							
		Type	rw							

Memory Organization
Table 3-7 CCU6 Register Overview (cont'd)

Addr	Register Name	Bit	7	6	5	4	3	2	1	0
9B _H	CCU6_CC63SRH Reset: 00 _H Capture/Compare Shadow Register for Channel CC63 High	Bit Field	CC63SH							
		Type	rw							
9C _H	CCU6_TCTR4L Reset: 00 _H Timer Control Register 4 Low	Bit Field	T12 STD	T12 STR	0	DTRES		T12 RES	T12RS	T12RR
		Type	w	w	r	w	w	w	w	
9D _H	CCU6_TCTR4H Reset: 00 _H Timer Control Register 4 High	Bit Field	T13 STD	T13 STR	0		T13 RES		T13RS	T13RR
		Type	w	w	r		w	w	w	
9E _H	CCU6_MCMOUTSL Reset: 00 _H Multi-Channel Mode Output Shadow Register Low	Bit Field	STRM CM	0	MCMPS					
		Type	w	r	rw					
9F _H	CCU6_MCMOUTSH Reset: 00 _H Multi-Channel Mode Output Shadow Register High	Bit Field	STRHP	0	CURHS			EXPHS		
		Type	w	r	rw			rw		
A4 _H	CCU6_ISR_L Reset: 00 _H Capture/Compare Interrupt Status Reset Register Low	Bit Field	RT12P M	RT12O M	RCC62 F	RCC62 R	RCC61 F	RCC61 R	RCC60 F	RCC60 R
		Type	w	w	w	w	w	w	w	w
A5 _H	CCU6_ISR_H Reset: 00 _H Capture/Compare Interrupt Status Reset Register High	Bit Field	RSTR	RIDL	RWHE	RCHE	0	RTRPF	RT13 PM	RT13 CM
		Type	w	w	w	w	r	w	w	w
A6 _H	CCU6_CMPMODIFL Reset: 00 _H Compare State Modification Register Low	Bit Field	0	MCC63 S	0		MCC62 S		MCC61 S	MCC60 S
		Type	r	w	r		w	w	w	
A7 _H	CCU6_CMPMODIFH Reset: 00 _H Compare State Modification Register High	Bit Field	0	MCC63 R	0		MCC62 R		MCC61 R	MCC60 R
		Type	r	w	r		w	w	w	
FA _H	CCU6_CC60SRL Reset: 00 _H Capture/Compare Shadow Register for Channel CC60 Low	Bit Field	CC60SL							
		Type	rwh							
FB _H	CCU6_CC60SRH Reset: 00 _H Capture/Compare Shadow Register for Channel CC60 High	Bit Field	CC60SH							
		Type	rwh							
FC _H	CCU6_CC61SRL Reset: 00 _H Capture/Compare Shadow Register for Channel CC61 Low	Bit Field	CC61SL							
		Type	rwh							
FD _H	CCU6_CC61SRH Reset: 00 _H Capture/Compare Shadow Register for Channel CC61 High	Bit Field	CC61SH							
		Type	rwh							
FE _H	CCU6_CC62SRL Reset: 00 _H Capture/Compare Shadow Register for Channel CC62 Low	Bit Field	CC62SL							
		Type	rwh							
FF _H	CCU6_CC62SRH Reset: 00 _H Capture/Compare Shadow Register for Channel CC62 High	Bit Field	CC62SH							
		Type	rwh							
RMAP = 0, Page 1										
9A _H	CCU6_CC63R_L Reset: 00 _H Capture/Compare Register for Channel CC63 Low	Bit Field	CC63VL							
		Type	rh							
9B _H	CCU6_CC63R_H Reset: 00 _H Capture/Compare Register for Channel CC63 High	Bit Field	CC63VH							
		Type	rh							
9C _H	CCU6_T12PRL Reset: 00 _H Timer T12 Period Register Low	Bit Field	T12PVL							
		Type	rwh							

Memory Organization
Table 3-7 CCU6 Register Overview (cont'd)

Addr	Register Name	Bit	7	6	5	4	3	2	1	0	
9D _H	CCU6_T12PRH Reset: 00 _H Timer T12 Period Register High	Bit Field	T12PVH								
		Type	rwh								
9E _H	CCU6_T13PRL Reset: 00 _H Timer T13 Period Register Low	Bit Field	T13PVL								
		Type	rwh								
9F _H	CCU6_T13PRH Reset: 00 _H Timer T13 Period Register High	Bit Field	T13PVH								
		Type	rwh								
A4 _H	CCU6_T12DTCL Reset: 00 _H Dead-Time Control Register for Timer T12 Low	Bit Field	DTM								
		Type	rw								
A5 _H	CCU6_T12DTCH Reset: 00 _H Dead-Time Control Register for Timer T12 High	Bit Field	0	DTR2	DTR1	DTR0	0	DTE2	DTE1	DTE0	
		Type	r	rh	rh	rh	r	rw	rw	rw	
A6 _H	CCU6_TCTRL0L Reset: 00 _H Timer Control Register 0 Low	Bit Field	CTM	CDIR	STE12	T12R	T12 PRE	T12CLK			
		Type	rw	rh	rh	rh	rw	rw			
A7 _H	CCU6_TCTRL0H Reset: 00 _H Timer Control Register 0 High	Bit Field	0		STE13	T13R	T13 PRE	T13CLK			
		Type	r		rh	rh	rw	rw			
FA _H	CCU6_CC60RL Reset: 00 _H Capture/Compare Register for Channel CC60 Low	Bit Field	CC60VL								
		Type	rh								
FB _H	CCU6_CC60RH Reset: 00 _H Capture/Compare Register for Channel CC60 High	Bit Field	CC60VH								
		Type	rh								
FC _H	CCU6_CC61RL Reset: 00 _H Capture/Compare Register for Channel CC61 Low	Bit Field	CC61VL								
		Type	rh								
FD _H	CCU6_CC61RH Reset: 00 _H Capture/Compare Register for Channel CC61 High	Bit Field	CC61VH								
		Type	rh								
FE _H	CCU6_CC62RL Reset: 00 _H Capture/Compare Register for Channel CC62 Low	Bit Field	CC62VL								
		Type	rh								
FF _H	CCU6_CC62RH Reset: 00 _H Capture/Compare Register for Channel CC62 High	Bit Field	CC62VH								
		Type	rh								
RMAP = 0, Page 2											
9A _H	CCU6_T12MSELL Reset: 00 _H T12 Capture/Compare Mode Select Register Low	Bit Field	MSEL61				MSEL60				
		Type	rw				rw				
9B _H	CCU6_T12MSELH Reset: 00 _H T12 Capture/Compare Mode Select Register High	Bit Field	DBYP	HSYNC			MSEL62				
		Type	rw	rw			rw				
9C _H	CCU6_IENL Reset: 00 _H Capture/Compare Interrupt Enable Register Low	Bit Field	ENT12 PM	ENT12 OM	ENCC 62F	ENCC 62R	ENCC 61F	ENCC 61R	ENCC 60F	ENCC 60R	
		Type	rw	rw	rw	rw	rw	rw	rw	rw	
9D _H	CCU6_IENH Reset: 00 _H Capture/Compare Interrupt Enable Register High	Bit Field	ENSTR	EN IDLE	EN WHE	EN CHE	0	EN TRPF	ENT13 PM	ENT13 CM	
		Type	rw	rw	rw	rw	r	rw	rw	rw	
9E _H	CCU6_INPL Reset: 40 _H Capture/Compare Interrupt Node Pointer Register Low	Bit Field	INPCHC		INPCC62		INPCC61		INPCC60		
		Type	rw		rw		rw		rw		

Memory Organization
Table 3-7 CCU6 Register Overview (cont'd)

Addr	Register Name	Bit	7	6	5	4	3	2	1	0	
9F _H	CCU6_INPH Reset: 39_H Capture/Compare Interrupt Node Pointer Register High	Bit Field	0		INPT13		INPT12		INPERR		
		Type	r		rw		rw		rw		
A4 _H	CCU6_ISSL Reset: 00_H Capture/Compare Interrupt Status Set Register Low	Bit Field	ST12P M	ST12O M	SCC62 F	SCC62 R	SCC61 F	SCC61 R	SCC60 F	SCC60 R	
		Type	w	w	w	w	w	w	w	w	
A5 _H	CCU6_ISSH Reset: 00_H Capture/Compare Interrupt Status Set Register High	Bit Field	SSTR	SIDLE	SWHE	SCHE	SWHC	STRPF	ST13 PM	ST13 CM	
		Type	w	w	w	w	w	w	w	w	
A6 _H	CCU6_PSLR Reset: 00_H Passive State Level Register	Bit Field	PSL63	0	PSL						
		Type	rwh	r	rwh						
A7 _H	CCU6_MCMCTR Reset: 00_H Multi-Channel Mode Control Register	Bit Field	0			SWSYN		0	SWSEL		
		Type	r			rw		r	rw		
FA _H	CCU6_TCTR2L Reset: 00_H Timer Control Register 2 Low	Bit Field	0	T13TED		T13TEC			T13 SSC	T12 SSC	
		Type	r	rw		rw			rw	rw	
FB _H	CCU6_TCTR2H Reset: 00_H Timer Control Register 2 High	Bit Field	0				T13RSEL		T12RSEL		
		Type	r				rw		rw		
FC _H	CCU6_MODCTRL Reset: 00_H Modulation Control Register Low	Bit Field	MC MEN	0	T12MODEN						
		Type	rw	r	rw						
FD _H	CCU6_MODCTRH Reset: 00_H Modulation Control Register High	Bit Field	ECT13 O	0	T13MODEN						
		Type	rw	r	rw						
FE _H	CCU6_TRPCTRL Reset: 00_H Trap Control Register Low	Bit Field	0					TRPM2	TRPM1	TRPM0	
		Type	r					rw	rw	rw	
FF _H	CCU6_TRPCTRH Reset: 00_H Trap Control Register High	Bit Field	TRPPE N	TRPEN 13	TRPEN						
		Type	rw	rw	rw						
RMAP = 0, Page 3											
9A _H	CCU6_MCMOUTL Reset: 00_H Multi-Channel Mode Output Register Low	Bit Field	0	R	MCMCP						
		Type	r	rh	rh						
9B _H	CCU6_MCMOUTH Reset: 00_H Multi-Channel Mode Output Register High	Bit Field	0		CURH			EXPH			
		Type	r		rh			rh			
9C _H	CCU6_ISL Reset: 00_H Capture/Compare Interrupt Status Register Low	Bit Field	T12PM	T12OM	ICC62F	ICC62 R	ICC61F	ICC61 R	ICC60F	ICC60 R	
		Type	rh	rh	rh	rh	rh	rh	rh	rh	
9D _H	CCU6_ISH Reset: 00_H Capture/Compare Interrupt Status Register High	Bit Field	STR	IDLE	WHE	CHE	TRPS	TRPF	T13PM	T13CM	
		Type	rh	rh	rh	rh	rh	rh	rh	rh	
9E _H	CCU6_PISEL0L Reset: 00_H Port Input Select Register 0 Low	Bit Field	ISTRP		ISCC62		ISCC61		ISCC60		
		Type	rw		rw		rw		rw		
9F _H	CCU6_PISEL0H Reset: 00_H Port Input Select Register 0 High	Bit Field	IST12HR		ISPOS2		ISPOS1		ISPOS0		
		Type	rw		rw		rw		rw		
A4 _H	CCU6_PISEL2 Reset: 00_H Port Input Select Register 2	Bit Field	0							IST13HR	
		Type	r							rw	
FA _H	CCU6_T12L Reset: 00_H Timer T12 Counter Register Low	Bit Field	T12CVL								
		Type	rwh								

Memory Organization
Table 3-7 CCU6 Register Overview (cont'd)

Addr	Register Name	Bit	7	6	5	4	3	2	1	0
FB _H	CCU6_T12H Reset: 00_H Timer T12 Counter Register High	Bit Field	T12CVH							
		Type	rwh							
FC _H	CCU6_T13L Reset: 00_H Timer T13 Counter Register Low	Bit Field	T13CVL							
		Type	rwh							
FD _H	CCU6_T13H Reset: 00_H Timer T13 Counter Register High	Bit Field	T13CVH							
		Type	rwh							
FE _H	CCU6_CMPSTATL Reset: 00_H Compare State Register Low	Bit Field	0	CC63 ST	CCPO S2	CCPO S1	CCPO S0	CC62 ST	CC61 ST	CC60 ST
		Type	r	rh	rh	rh	rh	rh	rh	rh
FF _H	CCU6_CMPSTATH Reset: 00_H Compare State Register High	Bit Field	T13IM	COU T63PS	COU T62PS	CC62 PS	COU T61PS	CC61 PS	COU T60PS	CC60 PS
		Type	rwh	rwh	rwh	rwh	rwh	rwh	rwh	rwh

3.3.5.8 SSC Registers

The SSC SFRs can be accessed in the standard memory area (RMAP = 0).

Table 3-8 SSC Register Overview

Addr	Register Name	Bit	7	6	5	4	3	2	1	0	
RMAP = 0											
A9 _H	SSC_PISEL Reset: 00_H Port Input Select Register	Bit Field	0					CIS	SIS	MIS	
		Type	r					rw	rw	rw	
AA _H	SSC_CONL Reset: 00_H Control Register Low <i>Programming Mode</i>	Bit Field	LB	PO	PH	HB	BM				
		Type	rw	rw	rw	rw	rw				
	<i>Operating Mode</i>	Bit Field	0					BC			
		Type	r					rh			
AB _H	SSC_CONH Reset: 00_H Control Register High <i>Programming Mode</i>	Bit Field	EN	MS	0	AREN	BEN	PEN	REN	TEN	
		Type	rw	rw	r	rw	rw	rw	rw	rw	
	<i>Operating Mode</i>	Bit Field	EN	MS	0	BSY	BE	PE	RE	TE	
		Type	rw	rw	r	rh	rwh	rwh	rwh	rwh	
AC _H	SSC_TBL Reset: 00_H Transmitter Buffer Register Low	Bit Field	TB_VALUE								
		Type	rw								
AD _H	SSC_RBL Reset: 00_H Receiver Buffer Register Low	Bit Field	RB_VALUE								
		Type	rh								
AE _H	SSC_BRL Reset: 00_H Baudrate Timer Reload Register Low	Bit Field	BR_VALUE[7:0]								
		Type	rw								
AF _H	SSC_BRH Reset: 00_H Baudrate Timer Reload Register High	Bit Field	BR_VALUE[15:8]								
		Type	rw								

3.3.5.9 OCDS Registers

The OCDS SFRs can be accessed in the mapped memory area (RMAP = 1).

Table 3-9 OCDS Register Overview

Addr	Register Name	Bit	7	6	5	4	3	2	1	0	
RMAP = 1											
E9 _H	MMCR2 Monitor Mode Control Register 2 Reset: 00_H	Bit Field	EXBC_P	EXBC	MBCO_N_P	MBCO_N	MMEP_P	MMEP	MMEP	MMOD_E	JENA
		Type	w	rw	w	rwh	w	rwh	rwh	rh	rh
F1 _H	MMCR Monitor Mode Control Register Reset: 00_H	Bit Field	MEXIT_P	MEXIT	MSTEP_P	MSTEP	MRAM_S_P	MRAM_S	TRF	RRF	
		Type	w	hw	w	rw	w	rwh	rh	rh	
F2 _H	MMSR Monitor Mode Status Register Reset: 00_H	Bit Field	MBCA_M	MBCIN	EXBF	SWBF	HWB3_F	HWB2_F	HWB1_F	HWB0_F	
		Type	rw	rh	rwh	rwh	rwh	rwh	rwh	rwh	
F3 _H	MMBPCR BreakPoints Control Register Reset: 00_H	Bit Field	SWBC	HWB3C		HWB2C		HWB1_C	HWB0C		
		Type	rw	rw		rw		rw	rw		
F4 _H	MMICR Monitor Mode Interrupt Control Register Reset: 00_H	Bit Field	DVECT	DRETR	0		MMUIE_P	MMUIE	RRIE_P	RRIE	
		Type	rwh	rwh	r		w	rw	w	rw	
F5 _H	MMDR Monitor Mode Data Register <i>Receive</i> Reset: 00_H	Bit Field	MMRR								
		Type	rh								
	<i>Transmit</i>	Bit Field	MMTR								
		Type	w								
F6 _H	HWBPSR Hardware Breakpoints Select Register Reset: 00_H	Bit Field	0			BPSEL_P	BPSEL				
		Type	r			w	rw				
F7 _H	HWBPDR Hardware Breakpoints Data Register Reset: 00_H	Bit Field	HWBPxx								
		Type	rw								

3.4 Boot ROM Operating Mode

After a reset, the CPU will always start by executing the Boot ROM code which occupies the program memory address space $0000_H - 1FFF_H$. The Boot ROM start-up procedure will first switch the address space for the Boot ROM to $C000_H - DFFF_H$, as shown in **Figure 3-6**. As a result, the program memory (Flash or ROM) previously occupying the address range $C000_H - DFFF_H$ will be mapped to $0000_H - 1FFF_H$ instead. After the address space switch, the remaining Boot ROM start-up procedure will be executed from $C00X_H$. This includes checking the latched values of pins MBC, TMS and P0.0 to enter the selected Boot ROM operating modes. Refer to **Chapter 7.2.3** for the selection of different Boot ROM operating modes. The memory organization of the XC866 shown in this document is after the address space switch where the different operating modes are executed.

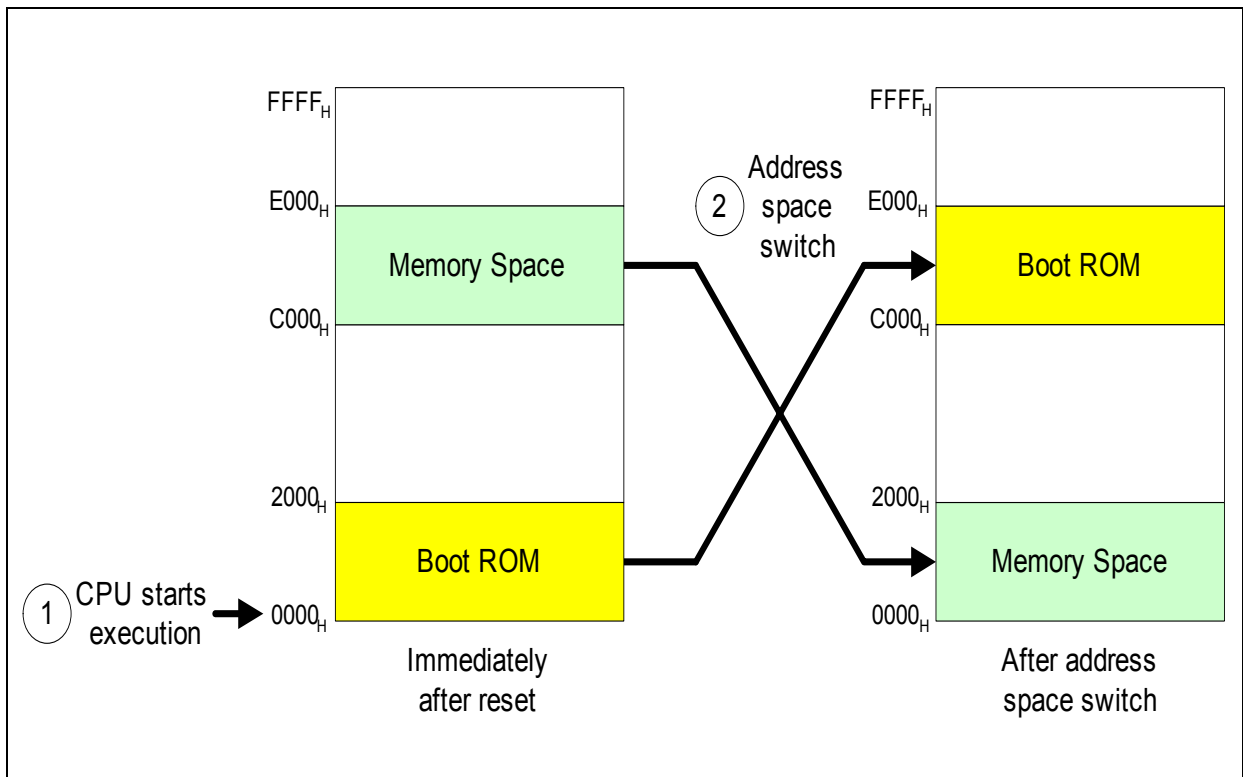

Figure 3-6 Boot ROM Address Space Switch

3.4.1 User Mode

If $(MBC, TMS, P0.0) = (1, x, x)$, the Boot ROM will jump to program memory address 0000_H to execute the user code in the Flash or ROM memory. This is the normal operating mode of the XC866.

3.4.2 BootStrap Loader Mode

If (MBC, TMS, P0.0) = (0, 0, x), the software routines of the BootStrap Loader (BSL) located in the Boot ROM will be executed, allowing the XRAM and Flash memory (if available) to be programmed, erased and executed. Refer to [Chapter 4.6](#) for the different BSL working modes.

3.4.3 OCDS Mode

If (MBC, TMS, P0.0) = (0, 1, 1), the OCDS mode will be entered for debugging program code. The OCDS hardware is initialized and a jump to program memory address 0000_H is next performed. The user code in the Flash or ROM memory is executed and the debugging process may be started.

During the OCDS mode, the lowest 64 bytes (00_H – 3F_H) in the internal data memory address range may be alternatively mapped to the 64-byte monitor RAM or the internal data RAM.

4 Flash Memory

The Flash memory provides an embedded user-programmable non-volatile memory, allowing fast and reliable storage of user code and data. It is operated from a single 2.5 V supply from the Embedded Voltage Regulator (EVR) and does not require additional programming or erasing voltage. The sectorization of the Flash memory allows each sector to be erased independently.

Features:

- In-System Programming (ISP) via UART
- In-Application Programming (IAP)
- Error Correction Code (ECC) for dynamic correction of single-bit errors
- 32-byte minimum program width
- 1-sector minimum erase width
- 1-byte read access
- $3 \times$ CCLK period read access time (inclusive of one wait state)

4.1 Flash Memory Map

The XC866 product family offers four Flash devices with either 8 Kbytes or 16 Kbytes of embedded Flash memory. These Flash memory sizes are made up of two or four 4-Kbyte Flash banks, respectively. Each Flash device consists of Program Flash (P-Flash) bank(s) and a single Data Flash (D-Flash) bank with different sectorization. The program memory map for the two different Flash sizes is shown in [Figure 4-1](#).

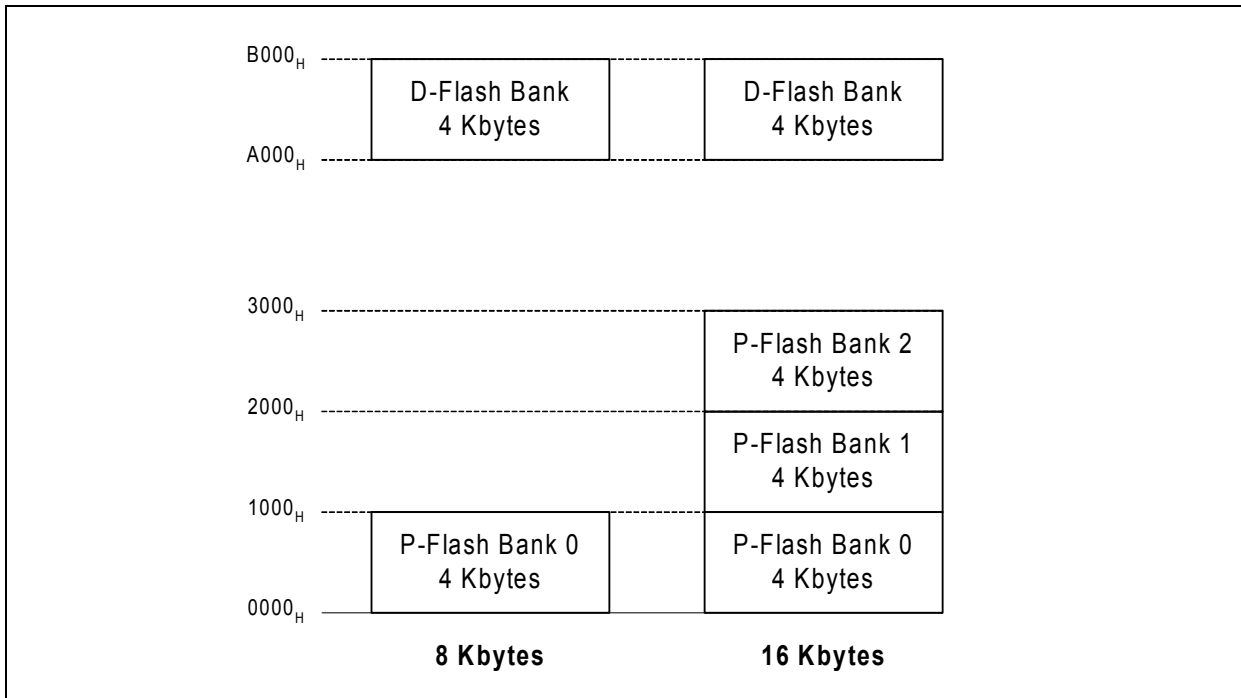

Figure 4-1 Flash Memory Map

For the 8-Kbyte Flash devices, P-Flash bank 0 is available and occupies the lower part of the program memory address, starting from 0000_H where the reset and interrupt vectors are located. For the 16-Kbyte Flash devices, two additional P-Flash banks (1 and 2) are provided for storing user code:

- P-Flash bank 1 occupies the address range 1000_H – 1FFF_H
- P-Flash bank 2 occupies 2000_H – 2FFF_H

All devices in the XC866 product family (including ROM devices) offer a 4-Kbyte D-Flash bank, occupying the address region A000_H – AFFF_H.

4.2 Flash Bank Sectorization

The XC866 Flash devices consist of two types of 4-Kbyte banks, namely Program Flash (P-Flash) bank and Data Flash (D-Flash) bank, with different sectorization as shown in **Figure 4-2**. Both types can be used for code and data storage. The label “Data” neither implies that the D-Flash is mapped to the data memory region, nor that it can only be used for data storage. It is used to distinguish the different Flash bank sectorizations.

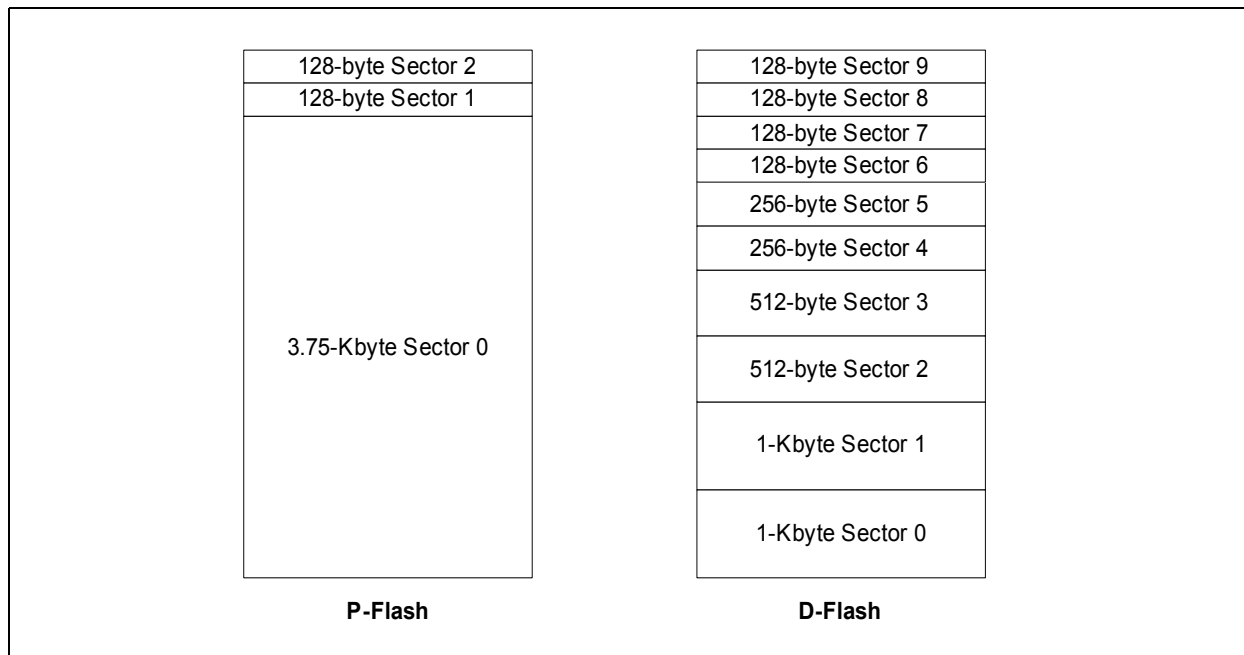

Figure 4-2 Flash Bank Sectorization

Sector Partitioning in P-Flash:

- One 3.75-Kbyte sector
- Two 128-byte sectors

Sector Partitioning in D-Flash:

- Two 1-Kbyte sectors
- Two 512-byte sectors
- Two 256-byte sectors
- Four 128-byte sectors

The internal structure of each Flash bank represents a sector architecture for flexible erase capability. The minimum erase width is always a complete sector, and sectors can be erased separately or in parallel. Contrary to standard EPROMs, erased Flash memory cells contain 0s.

Flash Memory

The D-Flash bank is divided into more physical sectors for extended erasing and reprogramming capability; even numbers for each sector size are provided to allow greater flexibility and the ability to adapt to a wide range of application requirements.

For example, the user's program can implement a buffer mechanism for each sector. Double copies of each data set can be stored in separate sectors of similar size to ensure that a backup copy of the data set is available in the event that the actual data set is corrupted or erased.

Alternatively, the user can implement an algorithm for EEPROM emulation, which uses the D-Flash bank like a circular stack memory; the latest data updates are always programmed on top of the actual region. When the top of the sector is reached, all actual data (representing the EEPROM data) is copied to the bottom area of the next sector and the last sector is then erased. This round robin procedure, using multifold replications of the emulated EEPROM size, significantly increases the endurance. To speed up data search, the RAM can be used to contain the pointer to the valid data set.

4.3 Wordline Address

The wordline (WL) addresses of the P-Flash and D-Flash banks are given in [Figure 4-3](#).

P-Flash 2				P-Flash 1				P-Flash 0				D-Flash			
Byte 31	Byte 2	Byte 1	Byte 0	Byte 31	Byte 2	Byte 1	Byte 0	Byte 31	Byte 2	Byte 1	Byte 0	Byte 31	Byte 2	Byte 1	Byte 0
2FF _H	2FE _H	2FE _{1H}	2FE _{0H}	1FF _H	1FE _H	1FE _{1H}	1FE _{0H}	0FF _H	0FE _H	0FE _{1H}	0FE _{0H}	AFF _H	AFE _H	AFE _{1H}	AFE _{0H}
2F9 _H	2F8 _H	2F8 _{1H}	2F8 _{0H}	1F9 _H	1F8 _H	1F8 _{1H}	1F8 _{0H}	0F9 _H	0F8 _H	0F8 _{1H}	0F8 _{0H}	AF9 _H	AF8 _H	AF8 _{1H}	AF8 _{0H}
2F7 _H	2F6 _H	2F6 _{1H}	2F6 _{0H}	1F7 _H	1F6 _H	1F6 _{1H}	1F6 _{0H}	0F7 _H	0F6 _H	0F6 _{1H}	0F6 _{0H}	AF7 _H	AF6 _H	AF6 _{1H}	AF6 _{0H}
2F1 _H	2F0 _H	2F0 _{1H}	2F0 _{0H}	1F1 _H	1F0 _H	1F0 _{1H}	1F0 _{0H}	0F1 _H	0F0 _H	0F0 _{1H}	0F0 _{0H}	AF1 _H	AF0 _H	AF0 _{1H}	AF0 _{0H}
2EF _H	2EE _H	2EE _{1H}	2EE _{0H}	1EF _H	1EE _H	1EE _{1H}	1EE _{0H}	0EF _H	0EE _H	0EE _{1H}	0EE _{0H}	AEE _H	AEE _{2H}	AEE _{1H}	AEE _{0H}
207 _H	206 _H	206 _{1H}	206 _{0H}	107 _H	106 _H	106 _{1H}	106 _{0H}	007 _H	006 _H	006 _{1H}	006 _{0H}	AE9 _H	AE8 _H	AE8 _{1H}	AE8 _{0H}
205 _H	204 _H	204 _{1H}	204 _{0H}	105 _H	104 _H	104 _{1H}	104 _{0H}	005 _H	004 _H	004 _{1H}	004 _{0H}	AE7 _H	AE6 _H	AE6 _{1H}	AE6 _{0H}
203 _H	202 _H	202 _{1H}	202 _{0H}	103 _H	102 _H	102 _{1H}	102 _{0H}	003 _H	002 _H	002 _{1H}	002 _{0H}	AE1 _H	AE0 _H	AE0 _{1H}	AE0 _{0H}
201 _H	200 _H	200 _{1H}	200 _{0H}	101 _H	100 _H	100 _{1H}	100 _{0H}	001 _H	000 _H	000 _{1H}	000 _{0H}	ADFF _H	ADE _{2H}	ADE _{1H}	ADE _{0H}
1F9 _H	1F8 _H	1F8 _{1H}	1F8 _{0H}	107 _H	106 _H	106 _{1H}	106 _{0H}	0FF _H	0FE _H	0FE _{1H}	0FE _{0H}	AD1 _H	AD0 _H	AD0 _{1H}	AD0 _{0H}
1F7 _H	1F6 _H	1F6 _{1H}	1F6 _{0H}	105 _H	104 _H	104 _{1H}	104 _{0H}	0F9 _H	0F8 _H	0F8 _{1H}	0F8 _{0H}	ACFF _H	ACE _{2H}	ACE _{1H}	ACE _{0H}
1F1 _H	1F0 _H	1F0 _{1H}	1F0 _{0H}	103 _H	102 _H	102 _{1H}	102 _{0H}	0F7 _H	0F6 _H	0F6 _{1H}	0F6 _{0H}	AC1 _H	AC0 _H	AC0 _{1H}	AC0 _{0H}
1EF _H	1EE _H	1EE _{1H}	1EE _{0H}	101 _H	100 _H	100 _{1H}	100 _{0H}	0F1 _H	0F0 _H	0F0 _{1H}	0F0 _{0H}	ABFF _H	ABE _{2H}	ABE _{1H}	ABE _{0H}
107 _H	106 _H	106 _{1H}	106 _{0H}	0FF _H	0FE _H	0FE _{1H}	0FE _{0H}	007 _H	006 _H	006 _{1H}	006 _{0H}	AA3 _H	AA2 _H	AA2 _{1H}	AA2 _{0H}
105 _H	104 _H	104 _{1H}	104 _{0H}	0F9 _H	0F8 _H	0F8 _{1H}	0F8 _{0H}	005 _H	004 _H	004 _{1H}	004 _{0H}	AA1 _H	AA0 _H	AA0 _{1H}	AA0 _{0H}
103 _H	102 _H	102 _{1H}	102 _{0H}	0F7 _H	0F6 _H	0F6 _{1H}	0F6 _{0H}	003 _H	002 _H	002 _{1H}	002 _{0H}	A9FF _H	A9E _{2H}	A9E _{1H}	A9E _{0H}
101 _H	100 _H	100 _{1H}	100 _{0H}	0F1 _H	0F0 _H	0F0 _{1H}	0F0 _{0H}	001 _H	000 _H	000 _{1H}	000 _{0H}	A7FF _H	A7E _{2H}	A7E _{1H}	A7E _{0H}
0F9 _H	0F8 _H	0F8 _{1H}	0F8 _{0H}	007 _H	006 _H	006 _{1H}	006 _{0H}	007 _H	006 _H	006 _{1H}	006 _{0H}	A45 _H	A44 _H	A44 _{1H}	A44 _{0H}
0F7 _H	0F6 _H	0F6 _{1H}	0F6 _{0H}	005 _H	004 _H	004 _{1H}	004 _{0H}	005 _H	004 _H	004 _{1H}	004 _{0H}	A43 _H	A42 _H	A42 _{1H}	A42 _{0H}
0F1 _H	0F0 _H	0F0 _{1H}	0F0 _{0H}	003 _H	002 _H	002 _{1H}	002 _{0H}	003 _H	002 _H	002 _{1H}	002 _{0H}	A41 _H	A40 _H	A40 _{1H}	A40 _{0H}
0EF _H	0EE _H	0EE _{1H}	0EE _{0H}	001 _H	000 _H	000 _{1H}	000 _{0H}	001 _H	000 _H	000 _{1H}	000 _{0H}	A3FF _H	A3E _{2H}	A3E _{1H}	A3E _{0H}
007 _H	006 _H	006 _{1H}	006 _{0H}	007 _H	006 _H	006 _{1H}	006 _{0H}	007 _H	006 _H	006 _{1H}	006 _{0H}	A05 _H	A04 _H	A04 _{1H}	A04 _{0H}
005 _H	004 _H	004 _{1H}	004 _{0H}	005 _H	004 _H	004 _{1H}	004 _{0H}	005 _H	004 _H	004 _{1H}	004 _{0H}	A03 _H	A02 _H	A02 _{1H}	A02 _{0H}
003 _H	002 _H	002 _{1H}	002 _{0H}	003 _H	002 _H	002 _{1H}	002 _{0H}	003 _H	002 _H	002 _{1H}	002 _{0H}	A01 _H	A00 _H	A00 _{1H}	A00 _{0H}
001 _H	000 _H	000 _{1H}	000 _{0H}	001 _H	000 _H	000 _{1H}	000 _{0H}	001 _H	000 _H	000 _{1H}	000 _{0H}				

Figure 4-3 Flash Wordline Addresses

A WL address can be calculated as follow:

$$0000_H + 20_H \times n, \text{ with } 0 \leq n \leq 127 \text{ for P-Flash 0} \quad [4.1]$$

$$1000_H + 20_H \times n, \text{ with } 0 \leq n \leq 127 \text{ for P-Flash 1} \quad [4.2]$$

$$2000_H + 20_H \times n, \text{ with } 0 \leq n \leq 127 \text{ for P-Flash 2} \quad [4.3]$$

$$A000_H + 20_H \times n, \text{ with } 0 \leq n \leq 127 \text{ for D-Flash} \quad [4.4]$$

Only one out of all the wordlines in the Flash banks can be programmed at a time. The width of each WL is 32 bytes (minimum/maximum program width). Before programming can be done, the user must first write 32 bytes of data into the IRAM using MOV instructions. Then, the BootStrap Loader (BSL) routine (see [Section 4.6](#)) or D-Flash program subroutine (see [Section 4.7.1](#)) will transfer these IRAM data to the corresponding write buffer of the targeted Flash bank. After 32 bytes of data are assembled in the write buffers, the programming sequence will start the charge pumps, storing the data content into the Flash cells along the selected WL. The WL is selected via the WL addresses shown in [Figure 4-3](#). It is necessary to fill the IRAM with 32 bytes of data, otherwise the previous values stored in the write buffers will remain and be programmed into the WL.

For the P-Flash banks, a programmed WL must be erased before it can be reprogrammed again as the Flash cells can only withstand one gate disturb. This means that the entire sector containing the WL must be erased since it is impossible to erase a single WL.

For the D-Flash bank, the same WL can be programmed twice before erasing is required as the Flash cells are able to withstand two gate disturbs. Hence, it is possible to program the same WL, for example, with 16 bytes of data in two times (see [Figure 4-4](#)).

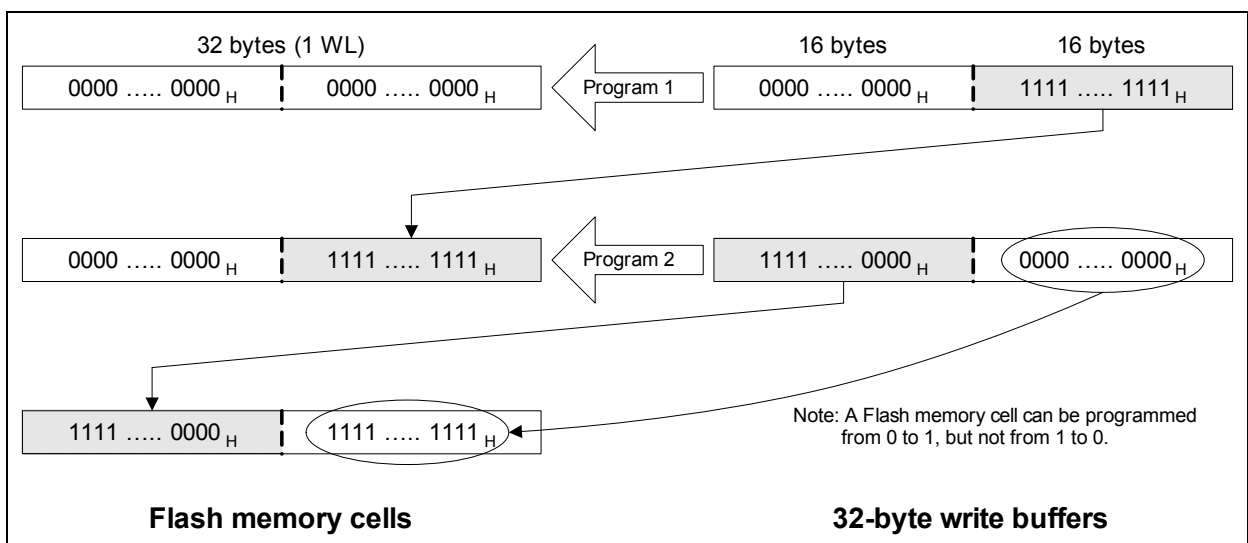

Figure 4-4 D-Flash Program

4.4 Operating Modes

The Flash operating modes for each bank are shown in [Figure 4-5](#).

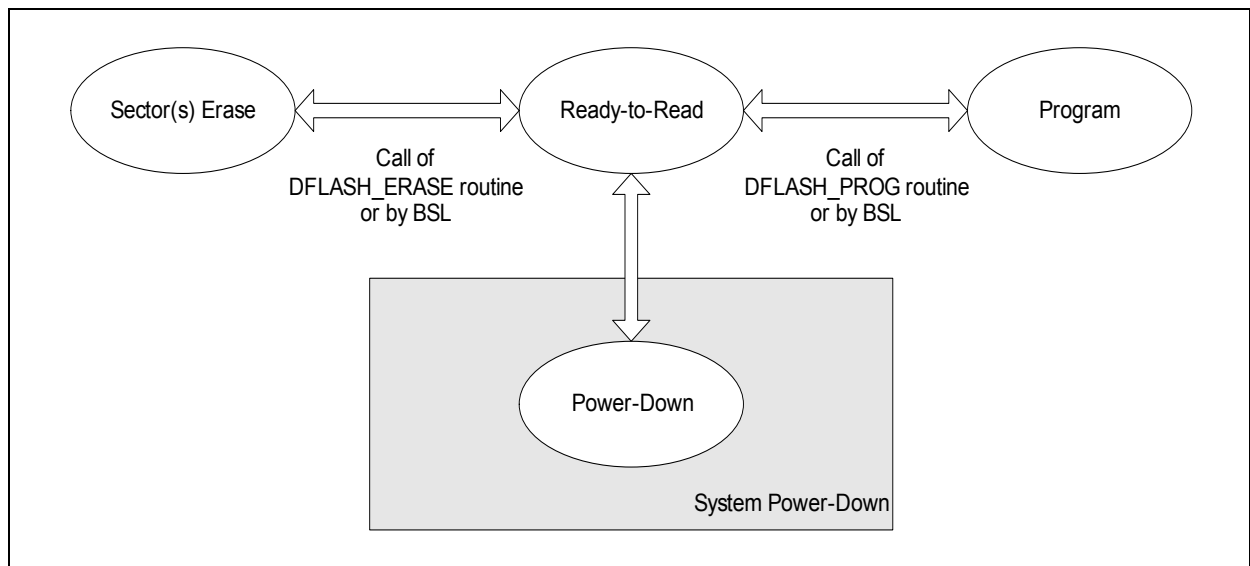

Figure 4-5 Flash Operating Modes

In general, the Flash operating modes are controlled by the BSL and D-Flash program/erase subroutines (see [Section 4.7](#)).

Each Flash bank must be in ready-to-read mode before the program mode or sector(s) erase mode can be entered. In the ready-to-read mode, the 32-byte write buffers for each Flash bank can be written, and the memory cell contents can be read via CPU access. In the program mode, data in the 32-byte write buffers is programmed into the Flash memory cells of the targeted wordline.

The operating modes for each Flash bank are enforced by its state machine to ensure the correct sequence of Flash mode transition. This avoids inadvertent destruction of the Flash contents with a reasonably low software overhead. The state machine also ensures that a Flash bank is blocked (no read access possible) while it is being programmed or erased. However, it is possible to program/erase one Flash bank while reading from another.

When the user sets bit `PMCON0.PD = 1` to enter the system power-down mode, the Flash banks will automatically be brought to its power-down state by hardware. Upon wake-up from system power-down, the Flash banks are brought to ready-to-read mode to allow access by the CPU.

4.5 Error Detection and Correction

The 8-bit data from the CPU is encoded with an Error Correction Code (ECC) before being stored in the Flash memory. During a read access, data is retrieved from the Flash memory and decoded for dynamic error detection and correction.

The correction algorithm (hamming code) has the capability to:

- Detect and correct all 1-bit errors
- Detect all 2-bit errors, but cannot correct

A corrected 1-bit error (result is valid) and an uncorrected 2-bit error (result is invalid) are not distinguished, with an ECC non-maskable interrupt (NMI) generated for both cases. The 16-bit Flash address at which the ECC error occurs is stored in the system control SFRs FEAL and FEAH, and can be accessed by the interrupt service routine to determine the Flash bank/sector in which the error occurred.

FEAL

Flash Error Address Register Low

Reset Value: 00_H

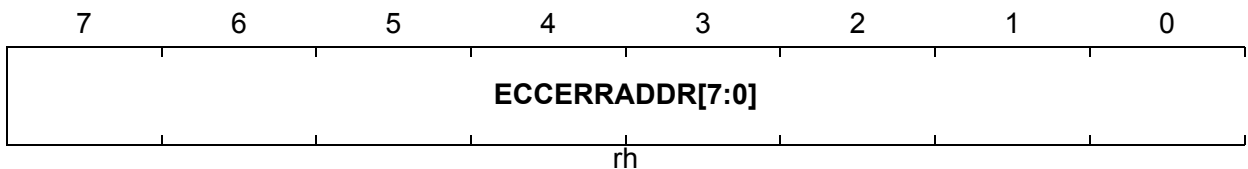

FEAH

Flash Error Address Register High

Reset Value: 00_H

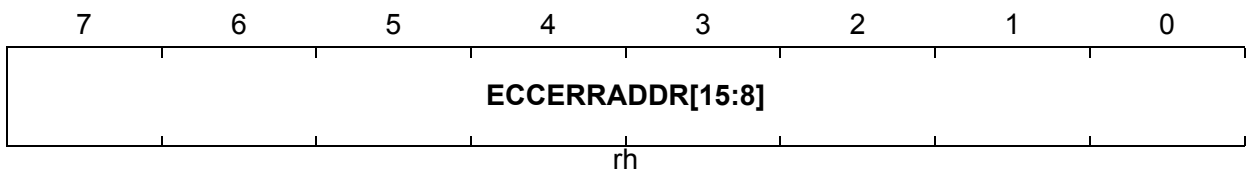

Field	Bits	Type	Description
ECCERRADDR	[7:0] of FEAL, [7:0] of FEAH	rh	ECC Error Address Value

4.6 In-System Programming

In-System Programming (ISP) of the Flash memory is supported via the Boot ROM-based BootStrap Loader (BSL), allowing a blank microcontroller device mounted onto an application board to be programmed with the user-code, and also a previously programmed device to be erased then reprogrammed without removal from the board. This feature offers ease-of-use and versatility for the embedded design.

ISP is supported through the microcontroller's serial interface (UART) which is connected to the personal computer host via the commonly available RS-232 serial cable. The BSL mode is selected if the latched values of the MBC and TMS pins are 0 after power-on or hardware reset. The BSL routine will first perform an automatic synchronization with the transfer speed (baud rate) of the serial communication partner (personal computer host). Communication between the BSL routine and the host is done via a simple transfer protocol; information is sent from the host to the microcontroller in blocks with specified block structure, and the BSL routine acknowledges the received data by returning a single acknowledge or error byte. User can program, erase or execute the P-Flash and/or D-Flash bank(s).

The available working modes are:

- Transfer user program from host to XRAM and/or Flash
- Execute user program in XRAM
- Execute user program in Flash
- Erase Flash sector(s) from the same or different bank(s)

4.7 In-Application Programming

In most applications, data in the D-Flash needs to be modified during program execution. In-Application Programming (IAP) is supported so that users can program or erase the D-Flash data from their Flash user program by calling some special subroutines that utilize the Flash Timer NMI. Hence, it is necessary to incorporate a Flash Timer NMI service routine code as part of the Flash user program. The Flash Timer NMI service routine is required as part of the D-Flash program and erase sequences.

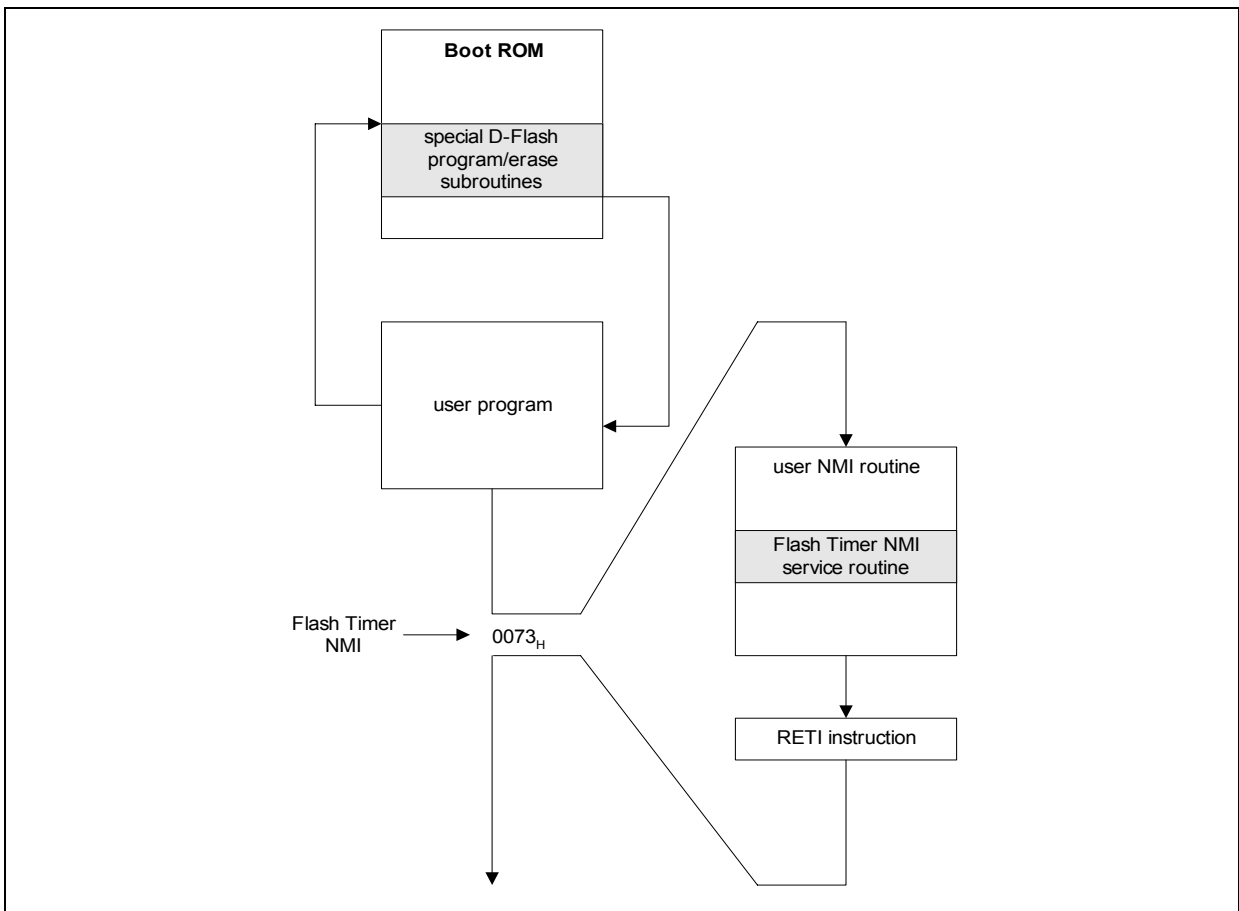

Figure 4-6 D-Flash Program/Erase Flow

4.7.1 D-Flash Programming

The Flash program subroutine can be called by the user to program 32 bytes of data into a single D-Flash wordline (WL). At the beginning of this subroutine, the Flash Timer NMI is enabled to enter the Flash Timer NMI service routine at each of the several timer underflows throughout the programming sequence.

Before calling this subroutine, the user must ensure that the 32-byte WL contents are stored incrementally in the IRAM, starting from the address specified in R0 of Register Bank 3. In addition, the input DPTR0 (EO.DPSEL0 = 0) must contain the D-Flash WL address. Otherwise, bit PSW.CY will be set and no programming will occur. If valid inputs are available before calling the subroutine, the microcontroller will continue to initialize the programming sequence (includes transferring the 32-byte IRAM data to the D-Flash write buffers), exit the subroutine and then return to the user program code. User program code will continue execution, from where it last stopped, until the next Flash Timer NMI is triggered and the Flash Timer NMI service routine entered (see [Figure 4-6](#)). The Flash Timer NMI service routine will first check the Flash Timer NMI status bit (NMISR.FNMIFLASHTIMER = 1) to ensure that the NMI source is from the Flash Timer before executing the remaining service routine instructions.

Table 4-1 D-Flash Program Subroutine

Subroutine	DFF6 _H : DFLASH_PROG
Input	DPTR0: D-Flash WL address
	R0 of Register Bank 3 (IRAM address 18 _H): IRAM start address for 32-byte D-Flash data
	32-byte D-Flash data
Output	PSW.CY: 0 = D-Flash programming is in progress 1 = DPTR0 is not pointing to valid D-Flash WL address
	DPTR0 is incremented by 20 _H
	Flash Timer NMI is enabled (NMICON.NMIFLASHTIMER = 1)
Stack size required	8
Resources used/destroyed	PSW.CY, A, SCU_PAGE, DPTR1
Resources reserved¹⁾	R0 – R7 of Register Bank 3 (IRAM address 18 _H – 1F _H)
	IRAM address 36 _H – 3D _H
Machine cycles taken²⁾	904

Flash Memory

- 1) The data in the reserved resources must not be altered throughout the programming period (including Flash Timer NMI servicing) to ensure correct programming flow.
- 2) Estimated value without wait state.

Upon completing the D-Flash programming sequence, the Flash Timer NMI will be disabled (NMICON.NMIFLASHTIMER = 0) by the program subroutine.

For 'end of D-Flash programming' indication, the user can check one of the following:

- Bit NMICON.NMIFLASHTIMER is cleared
- R3 of Register Bank 3 (IRAM address 1B_H) is 03_H

A manual check on the D-Flash data is necessary to determine the success of the programming via using the MOVC instruction to read out the D-Flash data.

4.7.2 D-Flash Erasing

The Flash erase subroutine can be called by the user to erase the sector(s) of the D-Flash bank. For each erasing sequence, it is possible to select one sector, a combination of several sectors or all 10 sectors to be erased. At the beginning of this subroutine, the Flash Timer NMI is enabled to enter the Flash Timer NMI service routine at each of the several timer underflows throughout the erasing sequence.

Before calling this subroutine, the user must ensure that R3 and R4 of Register Bank 3 are set accordingly. The microcontroller will first initialize the erasing sequence, exit the subroutine, then return to the user program code. User program code will continue execution, from where it last stopped, until the next Flash Timer NMI is triggered and the Flash Timer NMI service routine is entered (see [Figure 4-6](#)). The Flash Timer NMI service routine will first perform a check on the Flash Timer NMI status bit (NMISR.FNMIFLASHTIMER = 1) to ensure that the NMI source is from the Flash Timer before executing the remaining service routine instructions.

Table 4-2 D-Flash Erase Subroutine

Subroutine	DFF9 _H : DFLASH_ERASE
Input	R3 of Register Bank 3 (IRAM address 1B _H): Select sector(s) to be erased for D-Flash bank. LSB represents sector 0, MSB represents sector 7.
	R4 of Register Bank 3 (IRAM address 1C _H): Select sector(s) to be erased for D-Flash bank. LSB represents sector 8, bit 1 represents sector 9.
Output	Flash Timer NMI is enabled (NMICON.NMIFLASHTIMER = 1)
Stack size required	8
Resources used/destroyed	PSW.CY, A, SCU_PAGE, DPTR1
Resources reserved¹⁾	R0 – R7 of Register Bank 3 (IRAM address 18 _H – 1F _H)
	IRAM address 36 _H – 3D _H
Machine cycles taken ²⁾	358

¹⁾ The data in the reserved resources must not be altered throughout the erasing period (including Flash Timer NMI servicing) to ensure correct erasing flow.

²⁾ Estimated value without wait state.

Flash Memory

Upon completing the D-Flash erasing sequence, the Flash Timer NMI will be disabled (NMICON.NMIFLASHTIMER = 0) by the erase subroutine.

For 'end of D-Flash erasing' indication, the user can check for one of the following:

- Bit NMICON.NMIFLASHTIMER is cleared
- R3 of Register Bank 3 (IRAM address 1B_H) is 03_H

A manual check on the D-Flash data is necessary to determine the success of the erasing via a MOVC instruction.

5 Interrupt System

The XC800 Core supports one non-maskable interrupt (NMI) and 14 maskable interrupt requests. In addition to the standard interrupt functions supported by the core, e.g., configurable interrupt priority and interrupt masking, the XC866 interrupt system provides extended interrupt support capabilities such as the mapping of each interrupt vector to several interrupt sources to increase the number of interrupt sources supported, and additional status registers for detecting and determining the interrupt source.

5.1 Non-maskable Interrupt

The Non-Maskable Interrupt (NMI) is similar to regular interrupts, except it has the highest priority (over other regular interrupts) when addressing important system events. In the XC866, any one of the following seven events can generate an NMI:

- WDT prewarning has occurred
- The PLL has lost the lock to the external crystal
- Flash Timer has overflowed
- JTAG-receiving or user interrupt is requested in monitor mode
- VDD is below the prewarning voltage level (2.3 V)
- VDDP is below the prewarning voltage level (4.0 V if the external power supply is 5.0 V)
- Flash ECC error has occurred

The NMISR register is used to hold the NMI request flags for these events. Corresponding bits in the NMICON register determine whether the NMI requests will be accepted or ignored. When any enabled NMI request is serviced, the software routine may clear the NMI request flags in the NMISR register.

5.2 Maskable Interrupts

All regular interrupts are called maskable interrupts. A maskable interrupt can be masked or temporarily ignored by the processor while it completes its task. These interrupts can be classified into three types: internal interrupts, external interrupts, and extended interrupts.

5.2.1 Internal Interrupts

There are three internal interrupts that proceed from Timer 0, Timer 1, and UART. These interrupt request signals go directly to the XC800 Core and their interrupt status is maintained by the core.

Two interrupt flags TF0 and TF1 in the TCON register are set whenever Timer 0 or Timer 1, respectively, overflows. TF0 and TF1 are automatically cleared by hardware on entry to the corresponding interrupt service routine.

The UART interrupt source comprises the logical OR of the two serial interface interrupts. The interrupt flags RI and TI in register SCON are set automatically upon receipt or transmission of a data frame. These two bits must be cleared by software.

5.2.2 External Interrupts

Seven external interrupts, EXT_INT[6:0], are driven into the XC866 from the ports. External interrupts can be positive, negative or double edge triggered. Registers EXICON0 and EXICON1 specify the active edge for the triggering of the external interrupt.

Among the external interrupts, external interrupt 0 and external interrupt 1 can also be selected without edge detection. The interrupt request signal (caused with/without the edge triggered) to the core can further be programmed to either level activated or negative transition activated by setting or clearing bit ITx (x = 0 or 1), respectively, in the TCON register.

If the external interrupt is positive (negative) edge triggered, the external source must hold the request pin low (high) for at least one CCLK cycle, and then hold it high (low) for at least one CCLK cycle to ensure that the transition is recognized. If edge detection is bypassed for external interrupt 0 and external interrupt 1, the external source must hold the request pin “high” or “low” for at least two CCLK cycles.

5.2.3 Extended Interrupts

The extended interrupts are mainly for on-chip peripherals, which send interrupt requests to the core. There are nine interrupt request signals, XINTR_SRC[13:5], that are driven to the core, and each in turn receives an acknowledge signal XINTR_ACK[13:5] from the core.

Some interrupt sources have their own request flag(s) located in a special function register (e.g., TCON, T2CON, SCON). Registers IRCON0 and IRCON1 are used to hold other interrupt request flags for extended and external interrupts.

As the peripherals/devices have more interrupts lines than the core supports, some interrupts can be multiplexed and use the same interrupt input to the core. A few critical peripheral (e.g., timers, CCU6) interrupts are connected directly to the interrupt inputs of the core.

Each interrupt input requested by the corresponding flag can be individually enabled or disabled by the enable/disabled bit in the SFR IEN0 or IEN1. In addition, there is a global enable bit EA (contained in Register IEN0) for all interrupts, which when cleared, disables all interrupts independent of their individual enable bits.

Figure 5-1 to **Figure 5-5** give a general overview of the interrupt sources and illustrate the request and control flags.

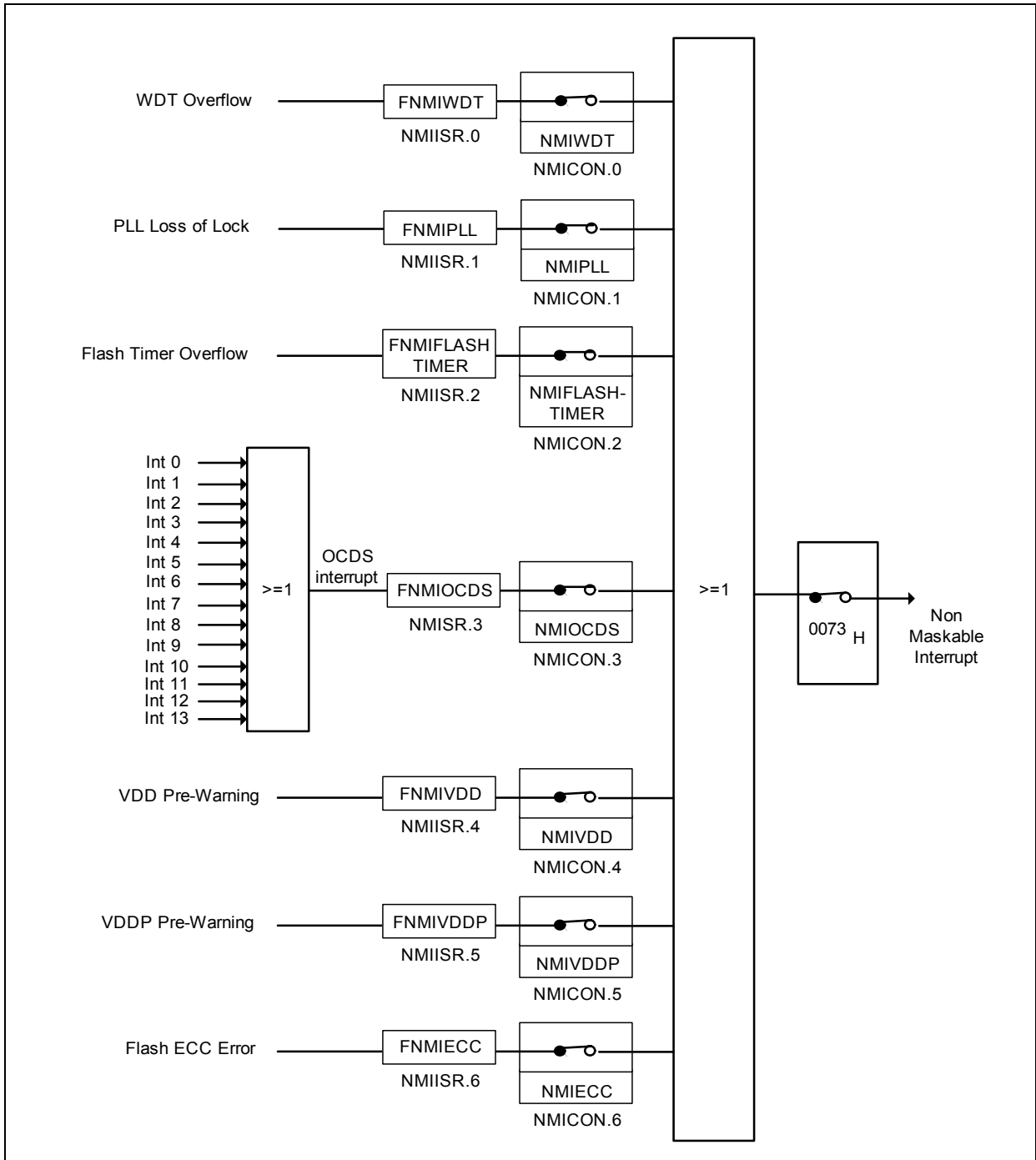

Figure 5-1 Non-Maskable Interrupt Request Source

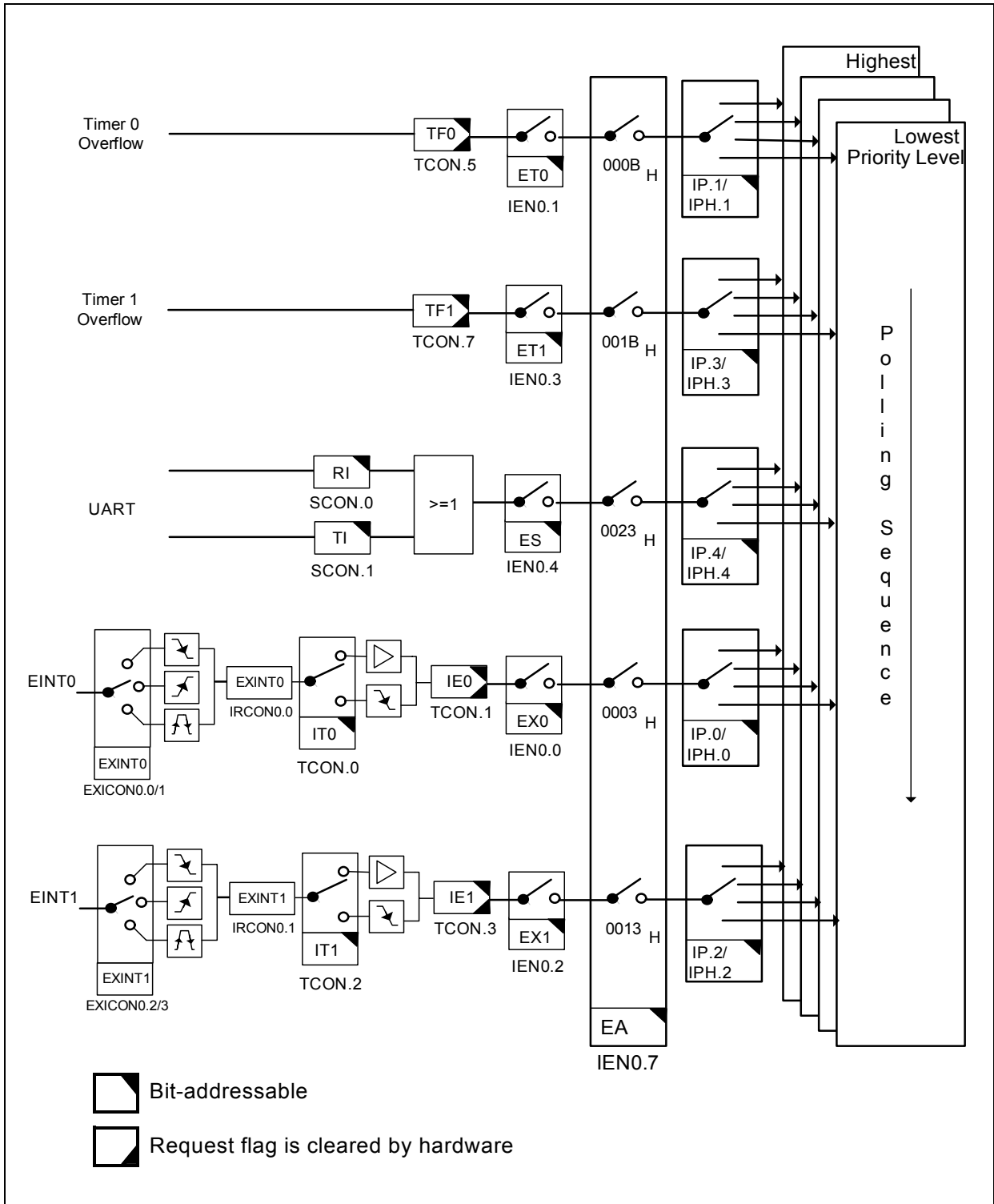

Figure 5-2 Interrupt Request Sources (Part 1)

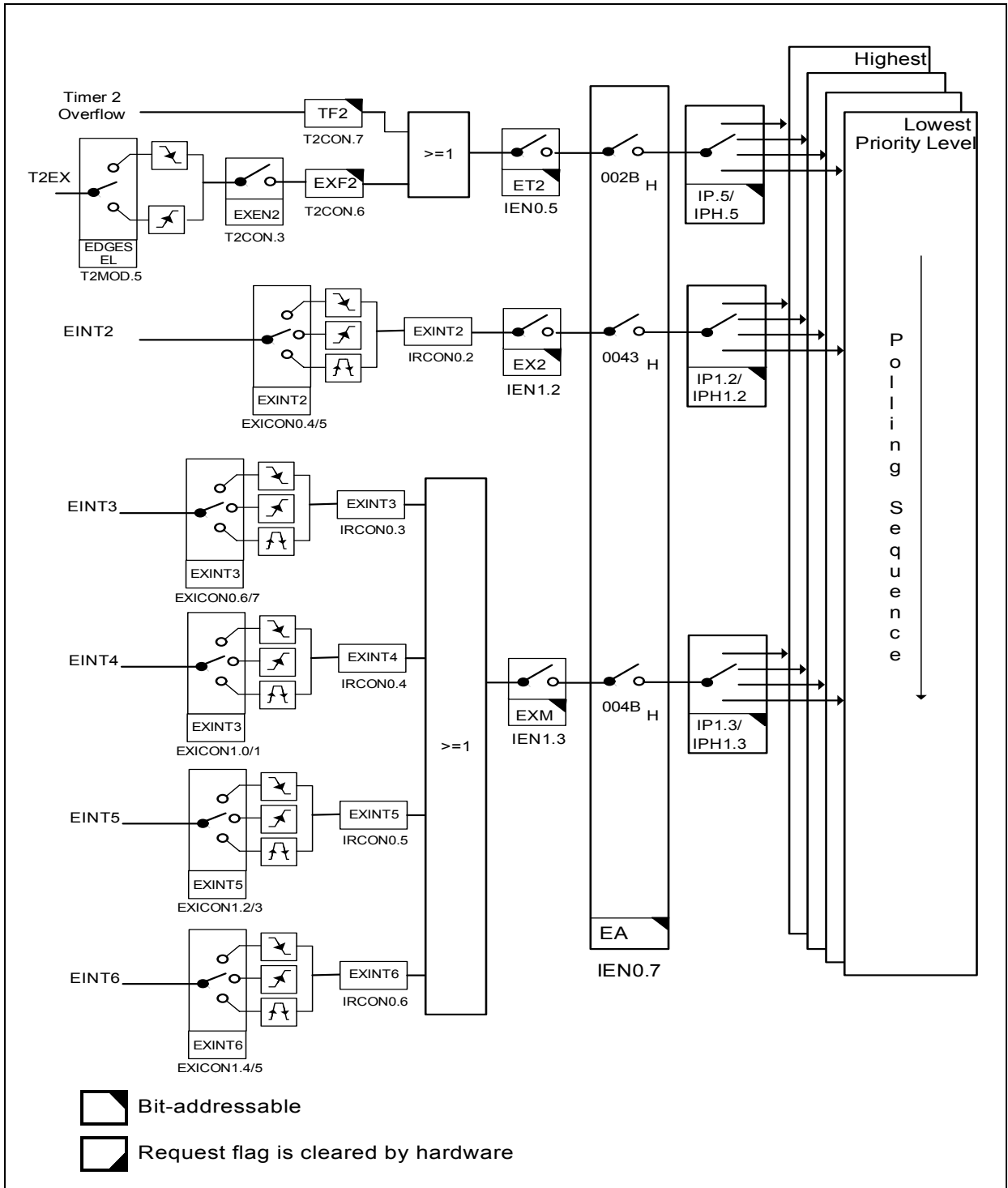

Figure 5-3 Interrupt Request Sources (Part 2)

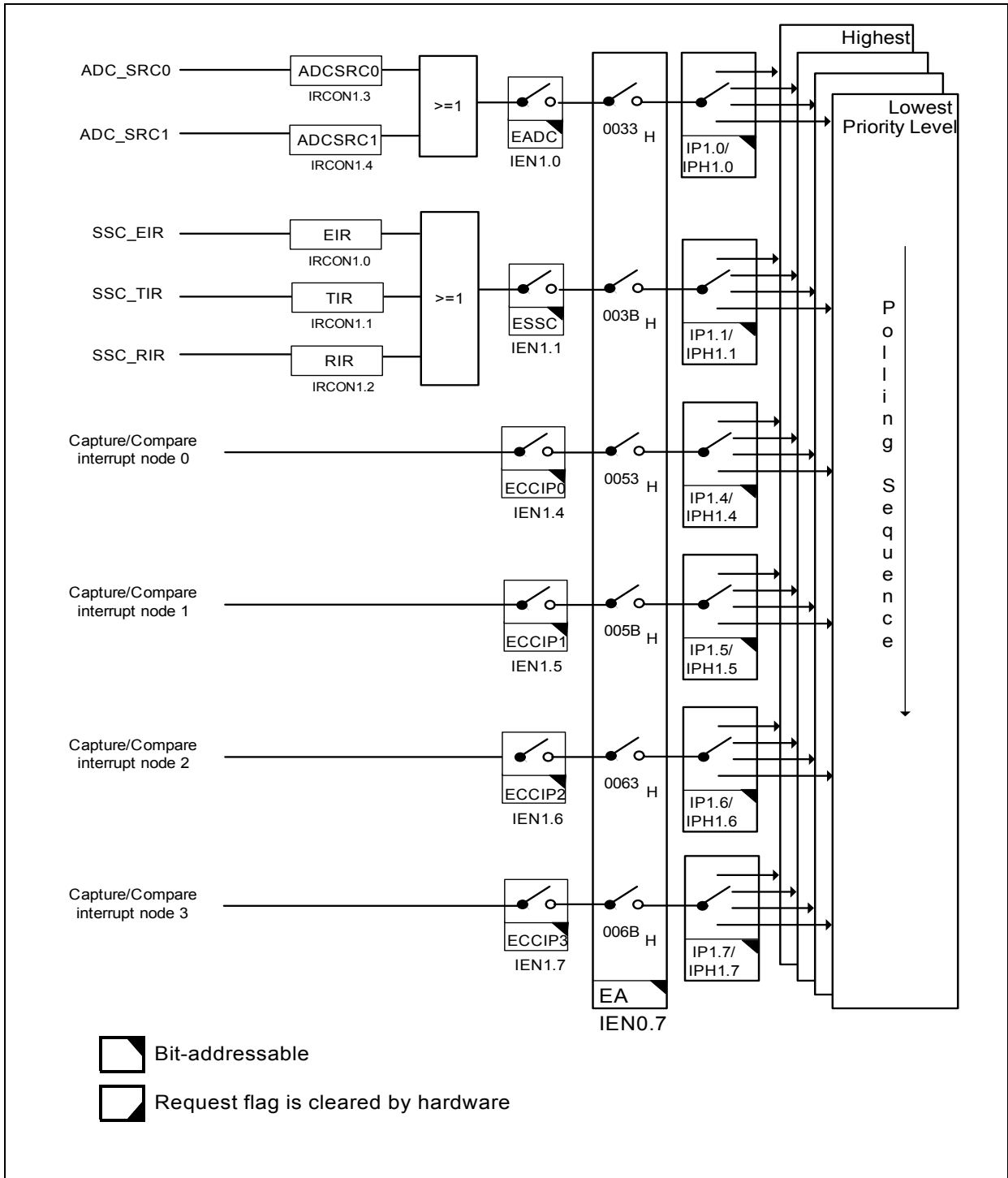

Figure 5-4 Interrupt Request Sources (Part 3)

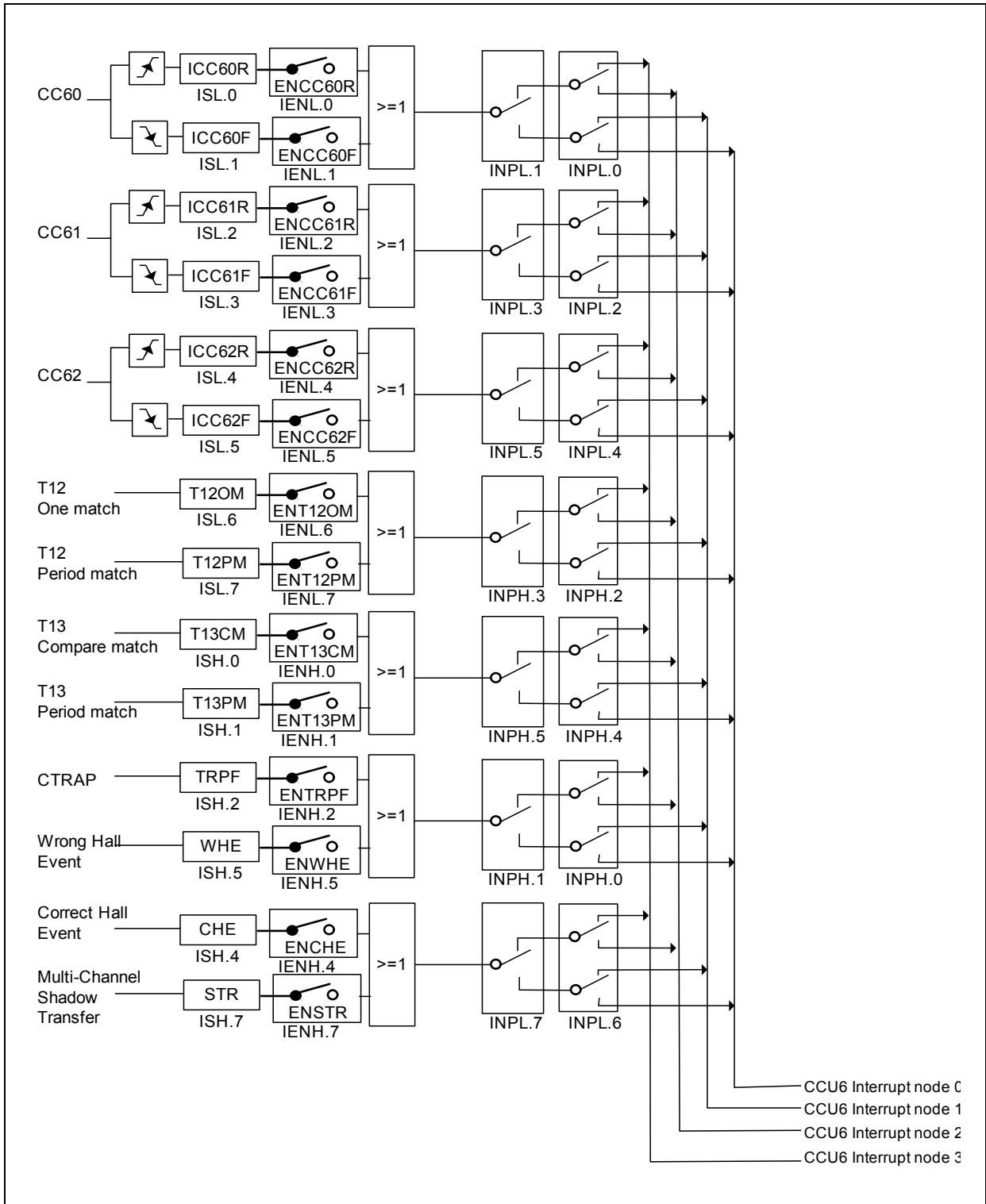

Figure 5-5 Interrupt Request Sources (Part 4)

5.3 Interrupt Source and Vector

Each interrupt input has an associated interrupt vector address. This vector is accessed in order to service the corresponding interrupt source. The assignment of the XC866 interrupt sources is summarized in [Table 5-1](#).

Table 5-1 Interrupt Vector Addresses

Interrupt Input	Vector Address	Interrupt Sources
NMI	0073 _H	Watchdog Timer, PLL, Flash Interface Timer, OCDS, VDD and VDDP prewarning, Flash ECC
XINTR0	0003 _H	External Interrupt 0
XINTR1	000B _H	Timer 0
XINTR2	0013 _H	External Interrupt 1
XINTR3	001B _H	Timer 1
XINTR4	0023 _H	UART
XINTR5	002B _H	Timer 2
XINTR6	0033 _H	ADC_SRC[1:0]
XINTR7	003B _H	SSC
XINTR8	0043 _H	External Interrupt 2
XINTR9	004B _H	External Interrupt [6:3]
XINTR10	0053 _H	CCU6 INP0
XINTR11	005B _H	CCU6 INP1
XINTR12	0063 _H	CCU6 INP2
XINTR13	006B _H	CCU6 INP3

5.4 Interrupt Register Description

5.4.1 Interrupt Enable Registers

Each interrupt input can be individually enabled or disabled by setting or clearing the corresponding bit in the interrupt enable registers IEN0 or IEN1. Register IEN0 also contains the global enable/disable bit (EA), which can be cleared to disable all interrupts.

The NMI interrupt is shared by a number of sources, each of which can be enabled or disabled individually via register NMICON.

After reset, the enable bits of IEN0, IEN1 and NMICON are cleared to 0. This implies that the corresponding interrupts are disabled.

IEN0

Interrupt Enable Register 0

Reset Value: 00_H

7	6	5	4	3	2	1	0
EA	0	ET2	ES	ET1	EX1	ET0	EX0
rw	r	rw	rw	rw	rw	rw	rw

Field	Bits	Type	Description
EX0	0	rw	Enable External Interrupt 0 0 External Interrupt 0 is disabled. 1 External Interrupt 0 is enabled.
ET0	1	rw	Enable Timer 0 Overflow Interrupt 0 Timer 0 Overflow interrupt is disabled. 1 Timer 0 Overflow interrupt is enabled.
EX1	2	rw	Enable External Interrupt 1 0 External interrupt 1 is disabled. 1 External interrupt 1 is enabled.
ET1	3	rw	Enable Timer 1 Overflow Interrupt 0 Timer 1 Overflow interrupt is disabled. 1 Timer 1 Overflow interrupt is enabled.
ES	4	rw	Enable Serial Port Interrupt 0 Serial Port interrupt is disabled. 1 Serial Port interrupt is enabled.
ET2	5	rw	Enable Timer 2 Interrupt 0 Timer 2 interrupt is disabled. 1 Timer 2 interrupt is enabled.

Interrupt System

Field	Bits	Type	Description
EA	7	rw	Enable/Disable All Interrupts 0 No interrupt will be acknowledged 1 Each interrupt source is individually enabled or disabled by setting or clearing its enable bit.
0	6	r	Reserved Returns 0 if read; should be written with 0.

IEN1
Interrupt Enable Register 1
Reset Value: 00_H

7	6	5	4	3	2	1	0
ECCIP3	ECCIP2	ECCIP1	ECCIP0	EXM	EX2	ESSC	EADC
rw	rw	rw	rw	rw	rw	rw	rw

Field	Bits	Type	Description
EADC	0	rw	ADC Interrupt Enable 0 ADC interrupts are disabled. 1 ADC interrupts are enabled.
ESSC	1	rw	SSC Interrupt Enable 0 SSC interrupts are disabled. 1 SSC interrupts are enabled.
EX2	2	rw	External Interrupt 2 Enable 0 External interrupt 2 is disabled. 1 External interrupt 2 is enabled.
EXM	3	rw	External Interrupts [6:3] Enable 0 External interrupts [6:3] are disabled. 1 External interrupt [6:3] are enabled.
ECCIP0	4	rw	CCU6 Interrupt Node Pointer 0 Enable 0 CCU6 Interrupt Node Pointer 0 is disabled. 1 CCU6 Interrupt Node Pointer 0 is enabled.
ECCIP1	5	rw	CCU6 Interrupt Node Pointer 1 Enable 0 CCU6 Interrupt Node Pointer 1 is disabled. 1 CCU6 Interrupt Node Pointer 1 is enabled.

Interrupt System

Field	Bits	Type	Description
ECCIP2	6	rw	CCU6 Interrupt Node Pointer 2 Enable 0 CCU6 Interrupt Node Pointer 2 is disabled. 1 CCU6 Interrupt Node Pointer 2 is enabled.
ECCIP3	7	rw	CCU6 Interrupt Node Pointer 3 Enable 0 CCU6 Interrupt Node Pointer 3 is disabled. 1 CCU6 Interrupt Node Pointer 3 is enabled.

NMICON
NMI Control Register
Reset Value: 00_H

7	6	5	4	3	2	1	0
0	NMIECC	NMIVDDP	NMIVDD	NMIOCDS	NMI-FLASH-TIMER	NMIPLL	NMIWDT
r	rw	rw	rw	rw	rw	rw	rw

Field	Bits	Type	Description
NMIWDT	0	rw	Watchdog Timer NMI Enable 0 WDT NMI is disabled. 1 WDT NMI is enabled.
NMIPLL	1	rw	PLL Loss of Lock NMI Enable 0 PLL Loss of Lock NMI is disabled. 1 PLL Loss of Lock NMI is enabled.
NMIFLASH-TIMER	2	rw	Flash Timer NMI Enable 0 Flash Timer NMI is disabled. 1 Flash Timer NMI is enabled.
NMIOCDS	3	rw	OCDS NMI Enable 0 OCDS NMI is disabled. 1 OCDS NMI is enabled.
NMIVDD	4	rw	VDD Prewarning NMI Enable 0 VDD NMI is disabled. 1 VDD NMI is enabled.
NMIVDDP	5	rw	VDDP Prewarning NMI Enable 0 VDDP NMI is disabled. 1 VDDP NMI is enabled. <i>Note: When the external power supply is 3.3 V, the user must disable NMIVDDP.</i>

Interrupt System

Field	Bits	Type	Description
NMIECC	6	rw	ECC NMI Enable 0 ECC NMI is disabled. 1 ECC NMI is enabled.
0	7	r	Reserved Returns 0 if read; should be written with 0.

EXICON0

External Interrupt Control Register 0

Reset Value: 00_H

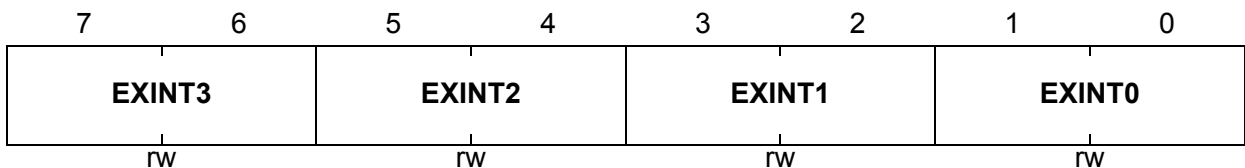

Field	Bits	Type	Description
EXINT0	[1:0]	rw	External Interrupt 0 Trigger Select 00 Interrupt on falling edge 01 Interrupt on rising edge 10 Interrupt on both rising and falling edge 11 Bypass the edge detection
EXINT1	[3:2]	rw	External Interrupt 1 Trigger Select 00 Interrupt on falling edge 01 Interrupt on rising edge 10 Interrupt on both rising and falling edge 11 Bypass the edge detection
EXINT2	[5:4]	rw	External Interrupt 2 Trigger Select 00 Interrupt on falling edge 01 Interrupt on rising edge 10 Interrupt on both rising and falling edge 11 Reserved
EXINT3	[7:6]	rw	External Interrupt 3 Trigger Select 00 Interrupt on falling edge 01 Interrupt on rising edge 10 Interrupt on both rising and falling edge 11 Reserved

EXICON1

External Interrupt Control Register 1

Reset Value: 00_H

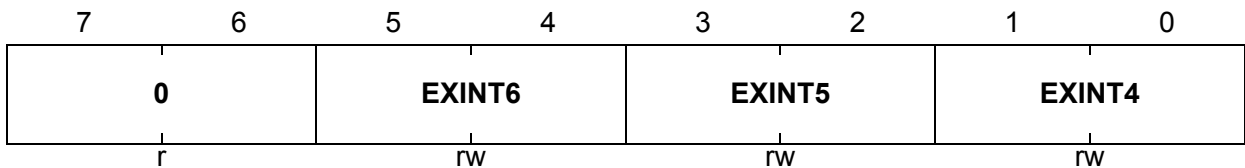

Field	Bits	Type	Description
EXINT4	[1:0]	rw	External Interrupt 4 Trigger Select 00 Interrupt on falling edge 01 Interrupt on rising edge 10 Interrupt on both rising and falling edge 11 Reserved
EXINT5	[3:2]	rw	External Interrupt 5 Trigger Select 00 Interrupt on falling edge 01 Interrupt on rising edge 10 Interrupt on both rising and falling edge 11 Reserved
EXINT6	[5:4]	rw	External Interrupt 6 Trigger Select 00 Interrupt on falling edge 01 Interrupt on rising edge 10 Interrupt on both rising and falling edge 11 Reserved
0	[7:6]	r	Reserved Returns 0 if read; should be written with 0.

5.4.2 Interrupt Request Flags

The interrupt request flags for the different sources are located in several Special Function Registers (SFRs). This section details the locations and meanings of these interrupt request flags.

IRCON0

Interrupt Request Register 0

Reset Value: 00_H

7	6	5	4	3	2	1	0
0	EXINT6	EXINT5	EXINT4	EXINT3	EXINT2	EXINT1	EXINT0
r	rwh	rwh	rwh	rwh	rwh	rwh	rwh

Field	Bits	Type	Description
EXINT_x (x = 0 - 6)	[6:0]	rwh	Interrupt Request Flag for External Interrupts This bit is set by hardware and can only be cleared by software. 0 Interrupt request is not active. 1 Interrupt request is active.
0	7	r	Reserved Returns 0 if read; should be written with 0.

Interrupt System

IRCON1

Interrupt Request Register 1

Reset Value: 00_H

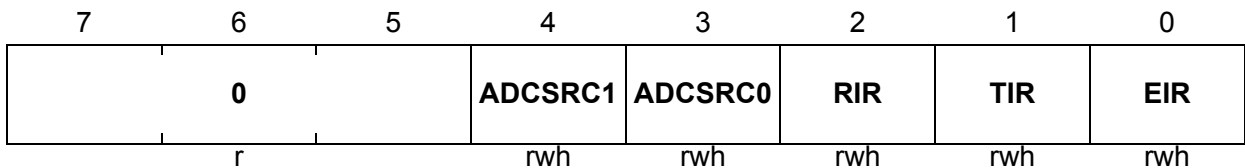

Field	Bits	Type	Description
EIR	0	rwh	Error Interrupt Request Flag for SSC This bit is set by hardware and can only be cleared by software. 0 Interrupt request is not active. 1 Interrupt request is active.
TIR	1	rwh	Transmit Interrupt Request Flag for SSC This bit is set by hardware and can only be cleared by software. 0 Interrupt request is not active. 1 Interrupt request is active.
RIR	2	rwh	Receive Interrupt Request Flag for SSC This bit is set by hardware and can only be cleared by software. 0 Interrupt request is not active. 1 Interrupt request is active.
ADCSRC0	3	rwh	Interrupt Request 0 Flag for ADC This bit is set by hardware and can only be cleared by software. 0 Interrupt request is not active. 1 Interrupt request is active.
ADCSRC1	4	rwh	Interrupt Request 1 Flag for ADC This bit is set by hardware and can only be cleared by software. 0 Interrupt request is not active. 1 Interrupt request is active.
0	[7:5]	r	Reserved Returns 0 if read; should be written with 0.

TCON
Timer Control Register

Reset Value: 00_H

7	6	5	4	3	2	1	0
TF1	TR1	TF0	TR0	IE1	IT1	IE0	IT0
rwh	rw	rwh	rw	rwh	rw	rwh	rw



The functions of the shaded bits are not described here

Field	Bits	Type	Description
IT0	0	rw	External Interrupt 0 Level/Edge Trigger Control Flag 0 Low level triggered external interrupt 0 is selected. 1 Falling edge triggered external interrupt 0 is selected.
IE0	1	rwh	External Interrupt 0 Request Flag Set by hardware when external interrupt 0 edge is detected. Cleared by hardware when the processor vectors to interrupt routine.
IT1	2	rw	External Interrupt 1 Level/Edge Trigger Control Flag 0 Low level triggered external interrupt 1 is selected. 1 Falling edge triggered external interrupt 1 is selected.
IE1	3	rwh	External Interrupt 1 Request Flag Set by hardware when external interrupt 1 edge is detected. Cleared by hardware when the processor vectors to interrupt routine.
TF0	5	rwh	Timer 0 Overflow Flag Set by hardware on Timer/Counter 0 overflow. Cleared by hardware when processor vectors to interrupt routine.

Interrupt System

Field	Bits	Type	Description
TF1	7	rwh	Timer 1 Overflow Flag Set by hardware on Timer/Counter 1 overflow. Cleared by hardware when processor vectors to interrupt routine.

SCON

Serial Channel Control Register

Reset Value: 00_H

7	6	5	4	3	2	1	0
SM0	SM1	SM2	REN	TB8	RB8	TI	RI
rw	rw	rw	rw	rw	rwh	rwh	rwh



The functions of the shaded bits are not described here

Field	Bits	Type	Description
RI	0	rwh	Serial Interface Receiver Interrupt Flag Set by hardware if a serial data byte has been received. Must be cleared by software.
TI	1	rwh	Serial Interface Transmitter Interrupt Flag Set by hardware at the end of a serial data transmission. Must be cleared by software.

NMISR

NMI Status Register

Reset Value: 00_H

7	6	5	4	3	2	1	0
0	FNMIIECC	FNMI VDDP	FNMI VDD	FNMI OCDS	FNMI-FLASH-TIMER	FNMIPLL	FNMIWDT
r	rwh	rwh	rwh	rwh	rwh	rwh	rwh

Field	Bits	Type	Description
FNMIWDT	0	rwh	Watchdog Timer NMI Flag 0 No Watchdog NMI occurred. 1 WDT prewarning has occurred.

Interrupt System

Field	Bits	Type	Description
FNMIPLL	1	rwh	PLL NMI Flag 0 No PLL NMI occurred. 1 The PLL has lost the lock to the external crystal.
FNMIFLASH-TIMER	2	rwh	Flash Timer NMI Flag 0 No Flash NMI occurred. 1 Flash Timer has overflowed.
FNMIOCDS	3	rwh	OCDS NMI Flag 0 No OCDS NMI occurred. 1 JTAG-receiving or user interrupt requested in monitor mode.
FNMIVDD	4	rwh	VDD Prewarning NMI Flag 0 No VDD NMI occurred. 1 V_{DD} is below the prewarning voltage level (2.3 V).
FNMIVDDP	5	rwh	VDDP Prewarning NMI Flag 0 No VDDP NMI occurred. 1 V_{DDP} is below the prewarning voltage level (4.0 V if the external power supply is 5.0 V).
FNMIECC	6	rwh	ECC NMI Flag 0 No ECC error occurred. 1 ECC error has occurred.
0	7	r	Reserved Returns 0 if read; should be written with 0.

Register NMISR can only be cleared by software or reset to the default value after the power-on reset/hardware reset/brownout reset. The register value is retained on any other reset such as watchdog timer reset or power-down wake-up reset. This allows the system to detect what caused the previous NMI.

5.4.3 Interrupt Priority Registers

Each interrupt source can be individually programmed to one of the four possible priority levels. Two pairs of interrupt priority registers are available to program the priority level of each interrupt vector. The first pair of registers is SFRs IP and IPH.

IP

Interrupt Priority Register

Reset Value: 00_H

7	6	5	4	3	2	1	0
0	PT2	PS	PT1	PX1	PT0	PX0	
r	rw	rw	rw	rw	rw	rw	rw

IPH

Interrupt Priority Register High

Reset Value: 00_H

7	6	5	4	3	2	1	0
0	PT2H	PSH	PT1H	PX1H	PT0H	PX0H	
r	rw	rw	rw	rw	rw	rw	rw

Field	Bits	Type	Description
PX0, PX0H	0	rw	Priority Level for External Interrupt 0
PT0, PT0H	1	rw	Priority Level for Timer 0 Overflow Interrupt
PX1, PX1H	2	rw	Priority Level for External Interrupt 1
PT1, PT1H	3	rw	Priority Level for Timer 1 Overflow Interrupt
PS, PSH	4	rw	Priority Level for Serial Port Interrupt
PT2, PT2H	5	rw	Priority Level for Timer 2 Interrupt
0	[7:6]	r	Reserved Returns 0 if read; should be written with 0.

Interrupt System

The second pair of interrupt priority registers is SFRs IP1 and IPH1.

IP1

Interrupt Priority Register 1

Reset Value: 00_H

7	6	5	4	3	2	1	0
PCCIP3	PCCIP2	PCCIP1	PCCIP0	PXM	PX2	PSSC	PADC
rw	rw	rw	rw	rw	rw	rw	rw

IPH1

Interrupt Priority Register 1 High

Reset Value: 00_H

7	6	5	4	3	2	1	0
PCCIP3H	PCCIP2H	PCCIP1H	PCCIP0H	PXMH	PX2H	PSSCH	PADCH
rw	rw	rw	rw	rw	rw	rw	rw

Field	Bits	Type	Description
PADC, PADCH	0	rw	Priority Level for ADC Interrupt
PSSC, PSSCH	1	rw	Priority Level for SSC Interrupt
PX2, PX2H	2	rw	Priority Level for External Interrupt 2
PXM, PXMH	3	rw	Priority Level for External Interrupt 3 to 6
PCCIP0, PCCIP0H	4	rw	Priority Level for CCU6 Interrupt Node Pointer 0
PCCIP1, PCCIP1H	5	rw	Priority Level for CCU6 Interrupt Node Pointer 1
PCCIP2, PCCIP2H	6	rw	Priority Level for CCU6 Interrupt Node Pointer 2
PCCIP3, PCCIP3H	7	rw	Priority Level for CCU6 Interrupt Node Pointer 3

5.4.4 Interrupt Priority

The respective bit fields of the interrupt priority registers together select one of the four priority levels as shown in [Table 5-2](#).

Table 5-2 Interrupt Priority Level Selection

IPH.x / IPH1.x	IP.x / IP1.x	Priority Level
0	0	Level 0 (lowest)
0	1	Level 1
1	0	Level 2
1	1	Level 3 (highest)

Note: As the NMI has the highest priority, it does not use the level selection shown in [Table 5-2](#).

A low-priority interrupt can be interrupted by a high-priority interrupt, but not by another interrupt of the same or lower priority. Further, an interrupt of the highest priority cannot be interrupted by any other interrupt source.

If two or more requests of different priority levels are received simultaneously, the request of the highest priority is serviced first. If requests of the same priority are received simultaneously, an internal polling sequence determines which request is serviced first. Thus, within each priority level, there is a second priority structure determined by the polling sequence as shown in [Table 5-3](#).

Table 5-3 Priority Structure within Interrupt Level

Source	Level
Non-Maskable Interrupt (NMI)	(highest)
External Interrupt 0	1
Timer 0 Interrupt	2
External Interrupt 1	3
Timer 1 Interrupt	4
UART Interrupt	5
Timer 2 Interrupt	6
ADC Interrupt	7
SSC Interrupt	8
External Interrupt 2	9
External Interrupt [6:3]	10
CCU6 Interrupt Node Pointer 0	11

Table 5-3 Priority Structure within Interrupt Level (cont'd)

Source	Level
CCU6 Interrupt Node Pointer 1	12
CCU6 Interrupt Node Pointer 2	13
CCU6 Interrupt Node Pointer 3	14

5.4.5 Interrupt Request Flags

The interrupt request flags are located in different SFRs. [Table 5-4](#) shows the bit locations of the interrupt request flags. Detailed information about the interrupt request flags is provided in the respective peripheral chapters.

Table 5-4 Locations of the Interrupt Request Flags

Interrupt Source	Request Flags	SFR
Timer 0 Interrupt	TF0	TCON
Timer 1 Interrupt	TF1	TCON
Timer 2 Interrupt	TF2	T2CON
	EXF2	T2CON
UART	RI	SCON
	TI	SCON
External Interrupt 0	IE0	TCON
External Interrupt 1	IE1	TCON
External Interrupt 2	EXINT2	IRCON0
External Interrupt 3	EXINT3	IRCON0
External Interrupt 4	EXINT4	IRCON0
External Interrupt 5	EXINT5	IRCON0
External Interrupt 6	EXINT6	IRCON0
ADC Interrupt	ADCSRC0	IRCON1
	ADCSRC1	IRCON1
SSC Interrupt	EIR	IRCON1
	TIR	IRCON1
	RIR	IRCON1
CCU6 Node 0 Interrupt	See note ¹⁾	INPL/INPH
CCU6 Node 1 Interrupt	See note ¹⁾	INPL/INPH
CCU6 Node 2 Interrupt	See note ¹⁾	INPL/INPH

Table 5-4 Locations of the Interrupt Request Flags (cont'd)

Interrupt Source	Request Flags	SFR
CCU6 Node 3 Interrupt	See note ¹⁾	INPL/INPH
Watchdog Timer NMI	FNMIWDT	NMISR
PLL NMI	FNMIPLL	NMISR
Flash Timer NMI	FNMI FLASHTIMER	NMISR
OCDS NMI	FNMIOCDS	NMISR
VDD NMI	FNMIVDD	NMISR
VDDP NMI	FNMIVDDP	NMISR
ECC NMI	FNMIIECC	NMISR

¹⁾ Different CCU6 interrupts can be assigned to different CCU6 interrupt nodes[3:0], which are selected via registers INPL/INPH.

5.5 Interrupt Handling

The interrupt flags are sampled at phase 2 in each machine cycle. The sampled flags are then polled during the following machine cycle. If one of the flags was in a set condition at phase 2 of the preceding cycle, the polling cycle will find it and the interrupt system will generate an LCALL to the appropriate service routine, provided this hardware-generated LCALL is not blocked by any of the following conditions:

- An interrupt of equal or higher priority is already in progress.
- The current (polling) cycle is not in the final cycle of the instruction in progress.
- The instruction in progress is RETI or any write access to registers IEN0/IEN1 or IP,IPH/IP1,IP1H.

Any of these three conditions will block the generation of the LCALL to the interrupt service routine. Condition 2 ensures that the instruction in progress is completed before vectoring to any service routine. Condition 3 ensures that if the instruction in progress is RETI or any write access to registers IEN0/IEN1 or IP,IPH/IP1,IP1H, then at least one more instruction will be executed before any interrupt is vectored to; this delay guarantees that changes of the interrupt status can be observed by the CPU.

The polling cycle is repeated with each machine cycle, and the values polled are the values that were present at phase 2 of the previous machine cycle. Note that if any interrupt flag is active but was not responded to for one of the conditions already mentioned, or if the flag was no longer active at the time of removal of the blocking condition, the denied interrupt will not be serviced. In other words, the fact that the interrupt flag was once active but not serviced is not remembered. Every polling cycle interrogates only the pending interrupt requests.

Figure 5-6 shows the timing example for extended interrupts.

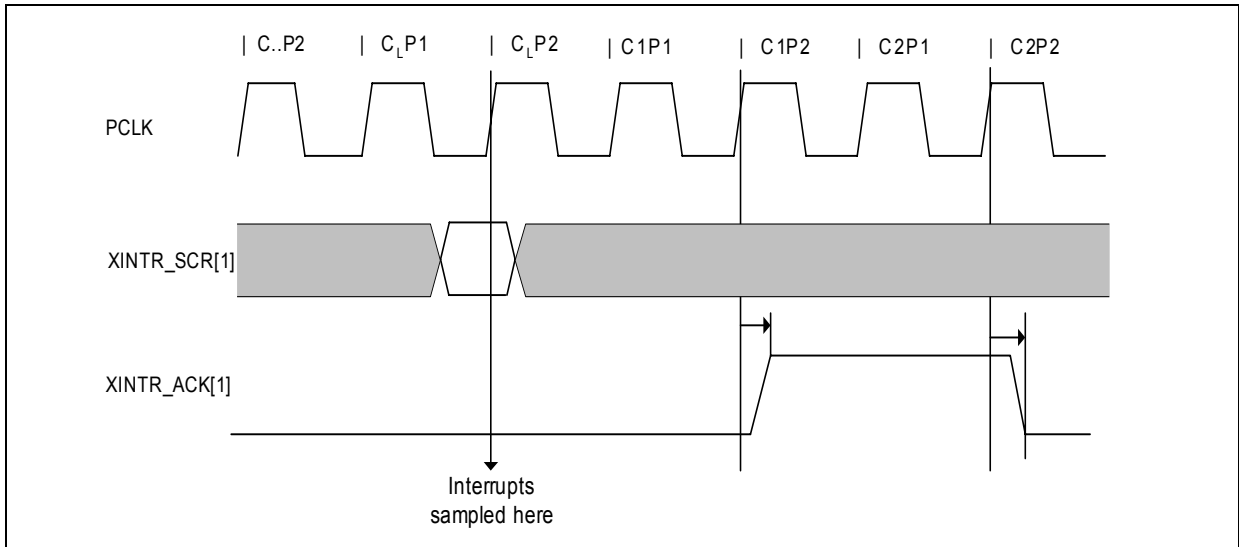

Figure 5-6 Timing for Extended Interrupt

The processor acknowledges an interrupt request by executing a hardware generated LCALL to the appropriate servicing routine. In some cases, hardware also clears the flag that generated the interrupt, while in other cases, the flag must be cleared by the user's software. The hardware-generated LCALL pushes the contents of the Program Counter (PC) onto the stack (but it does not save the PSW) and reloads the PC with an address that depends on the source of the interrupt being vectored to, as shown in the [Table 5-1](#).

Program execution returns to the next instruction after calling the interrupt when the RETI instruction is encountered. The RETI instruction informs the processor that the interrupt routine is no longer in progress, then pops the two top bytes from the stack and reloads the PC. Execution of the interrupted program continues from the point where it was stopped. Note that the RETI instruction is important because it informs the processor that the program has left the current interrupt priority level. A simple RET instruction would also have returned execution to the interrupted program, but it would have left the interrupt control system on the assumption that an interrupt was still in progress. In this case, no interrupt of the same or lower priority level would be acknowledged.

5.6 Interrupt Response Time

If an interrupt is recognized, its corresponding request flag is set at phase 2 in every machine cycle. The value is not polled by the circuitry until the next machine cycle. If the request is active and conditions are right for it to be acknowledged, a hardware subroutine call to the requested service routine will be the next instruction to be executed. The call itself takes two machine cycles. Thus, a minimum of three complete machine cycles will elapse from activation of the interrupt request to the beginning of execution of the first instruction of the service routine. A longer response time would be obtained if the request is blocked by one of the three previously listed conditions. If an

Interrupt System

interrupt of equal or higher priority is already in progress, the additional wait time will depend on the nature of the other interrupt's service routine. If the instruction in progress is not in its final cycle, the additional wait time cannot be more than three machine cycles. The longest instructions (MUL and DIV) are only four machine cycles long. If the instruction in progress is RETI or a write access to registers IEN0, IEN1 or IP(H), IP1(H), the additional wait time cannot be more than five cycles (a maximum of one more machine cycle to complete the instruction in progress, plus four machine cycles to complete the next instruction, if the instruction is MUL or DIV). Thus, in a single interrupt system, if the wait states are not considered, the response time is between three and nine machine cycles.

6 Parallel Ports

The XC866 has 27 port pins organized into four parallel ports, Port 0 (P0) to Port 3 (P3). Each pin has a pair of internal pull-up and pull-down devices that can be individually enabled or disabled. Ports P0, P1 and P3 are bidirectional and can be used as general purpose input/output (GPIO) or to perform alternate input/output functions for the on-chip peripherals. When configured as an output, the open drain mode can be selected. Port P2 is an input-only port, providing general purpose input functions, alternate input functions for the on-chip peripherals, and also analog inputs for the Analog-to-Digital Converter (ADC).

Bidirectional Port Features:

- Configurable pin direction
- Configurable pull-up/pull-down devices
- Configurable open drain mode
- Transfer of data through digital inputs and outputs (general purpose I/O)
- Alternate input/output for on-chip peripherals

Input Port Features:

- Configurable pull-up/pull-down devices
- Receive of data through digital input (general purpose input)
- Alternate input for on-chip peripherals
- Analog input for ADC module

6.1 General Port Operation

Figure 6-1 shows the block diagram of an XC866 bidirectional port pin. Each port pin is equipped with a number of control and data bits, thus enabling very flexible usage of the pin. By defining the contents of the control register, each individual pin can be configured as an input or an output. The user can also configure each pin as an open drain pin with or without internal pull-up/pull-down device.

Each bidirectional port pin can be configured for input or output operation. Switching between input and output mode is accomplished through the register `Px_DIR` ($x = 0, 1$ or 3), which enables or disables the output and input drivers. A port pin can only be configured as either input or output mode at any one time.

In input mode (default after reset), the output driver is switched off (high-impedance). The actual voltage level present at the port pin is translated into a logic 0 or 1 via a Schmitt-Trigger device and can be read via the register `Px_DATA`.

In output mode, the output driver is activated and drives the value supplied through the multiplexer to the port pin. In the output driver, each port line can be switched to open drain mode or normal mode (push-pull mode) via the register `Px_OD`.

The output multiplexer in front of the output driver enables the port output function to be used for different purposes. If the pin is used for general purpose output, the multiplexer is switched by software to the data register `Px_DATA`. Software can set or clear the bit in `Px_DATA` and therefore directly influence the state of the port pin. If an on-chip peripheral uses the pin for output signals, alternate output lines (AltDataOut) can be switched via the multiplexer to the output driver circuitry. Selection of the alternate function is defined in registers `Px_ALTSEL0` and `Px_ALTSEL1`. When a port pin is used as an alternate function, its direction must be set accordingly in the register `Px_DIR`.

Each pin can also be programmed to activate an internal weak pull-up or pull-down device. Register `Px_PUDSEL` selects whether a pull-up or the pull-down device is activated while register `Px_PUDEN` enables or disables the pull device.

To achieve high speed I/O data transfer, each I/O pin can be switched for direct connection to the various inputs of the peripheral units (AltDataIn). The function of the input line from the pin to the data register `Px_DATA` and to AltDataIn is independent of whether the port pin operates as input or output. This means that when the pin is in output mode, the level of the pin can be read by software via `Px_DATA` or a peripheral can use the pin level as an input. This offers additional advantages in an application:

- When the pin is configured as general purpose output, the data written to the data register `Px_DATA` by software can be used as input data to an on-chip peripheral. This enables, for example, peripheral tests via software without external circuitry. Examples for this can be the triggering of a timer count input, generating an external interrupt, or simulating the incoming serial data stream to a serial port receive input via software.

Parallel Ports

- When the pin is configured for alternate output function, the output data that is driven to the pin by a peripheral can be read through software via Px_DATA or used by the same or another peripheral as input data. This enables testing of peripheral functions or provides additional connections between on-chip peripherals via the same pin without external wires.

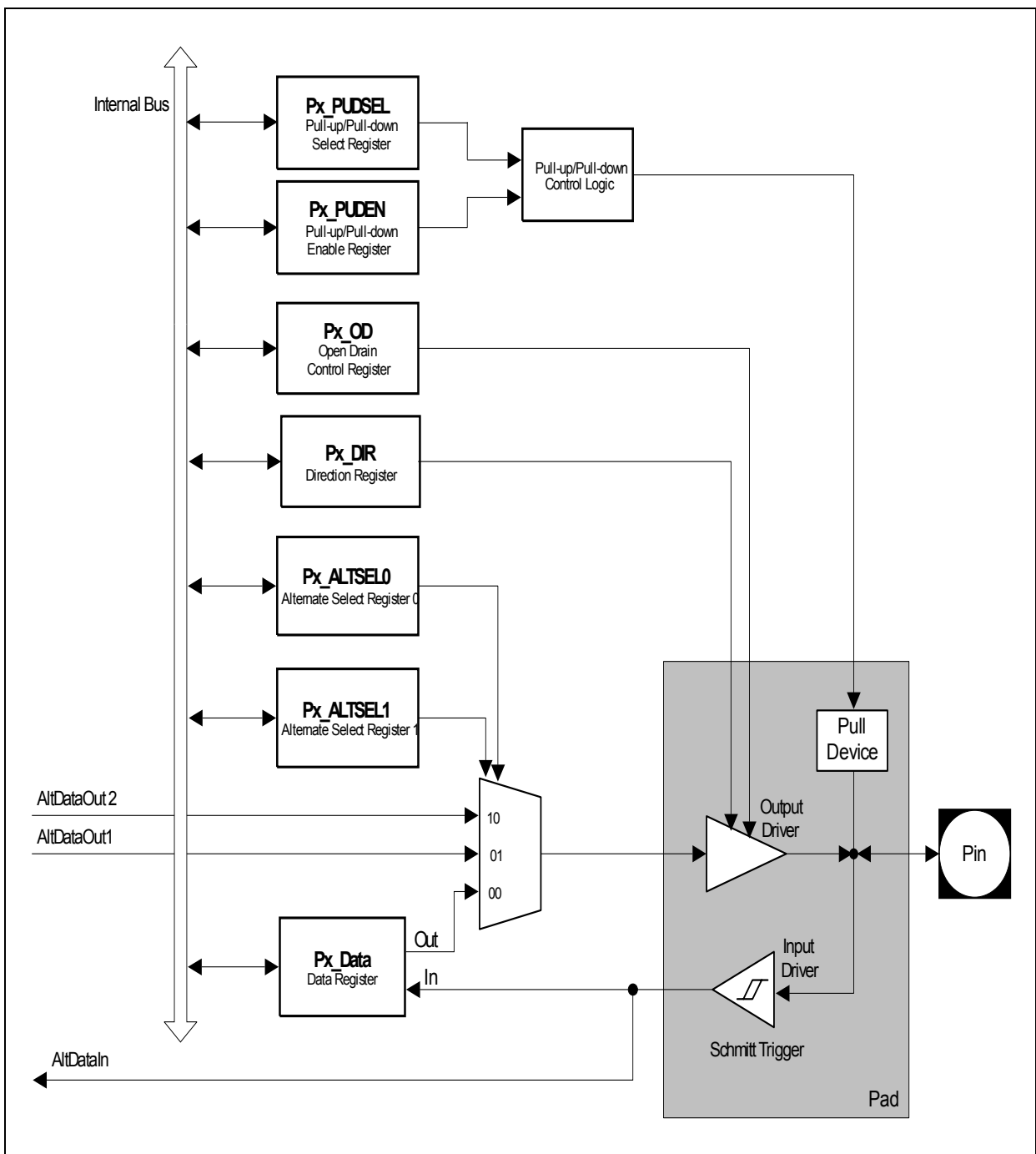

Figure 6-1 General Structure of Bidirectional Port

Figure 6-2 shows the structure of an input-only port pin. Each P2 pin can only function in input mode. The actual voltage level present at the port pin is translated into a logic 0 or 1 via a Schmitt-Trigger device and can be read via the register P2_DATA. Each pin can also be programmed to activate an internal weak pull-up or pull-down device. Register P2_PUDSEL selects whether a pull-up or the pull-down device is activated while register P2_PUDEN enables or disables the pull device. The analog input (AnalogIn) bypasses the digital circuitry and Schmitt-Trigger device for direct feed-through to the ADC input channel.

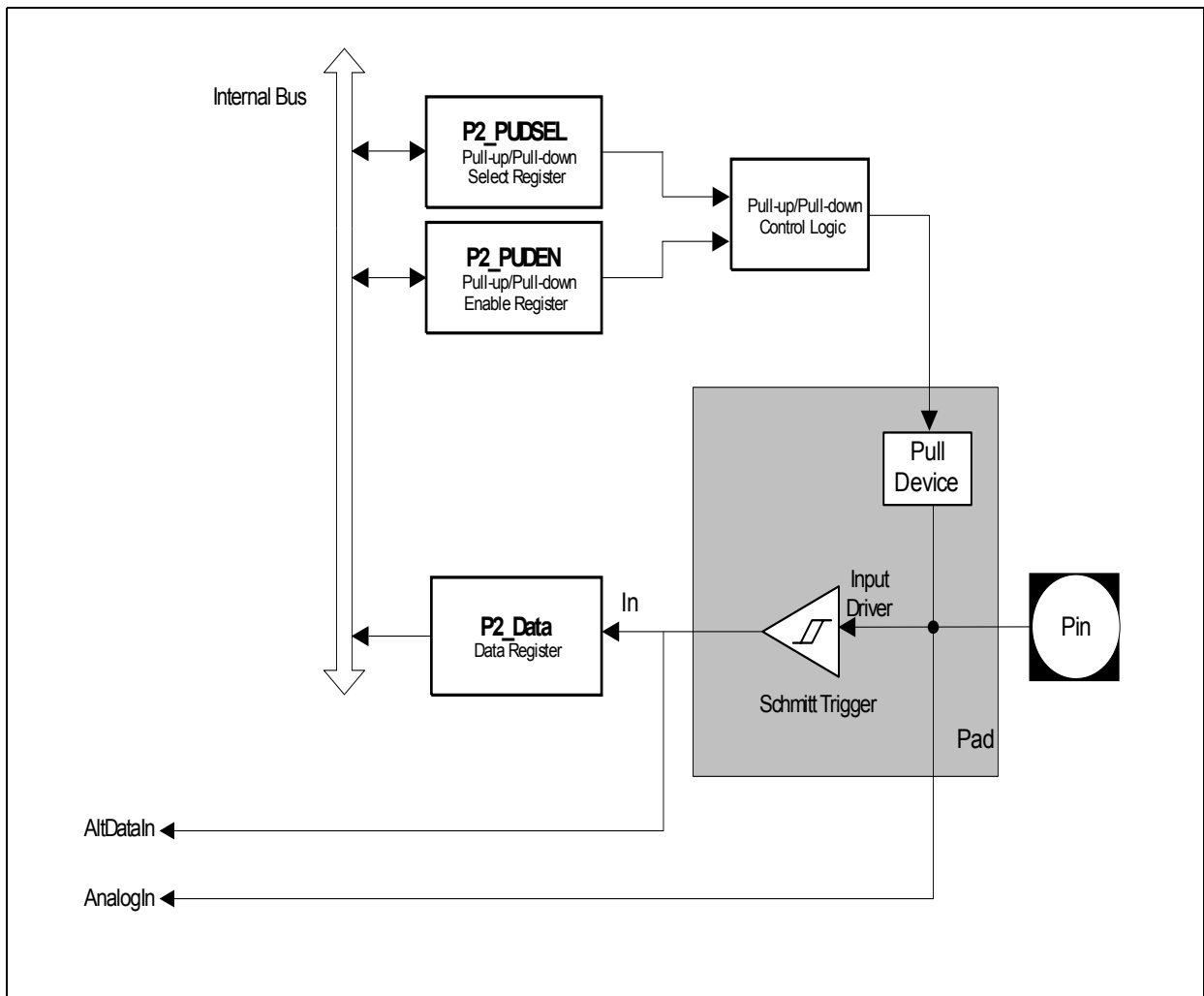

Figure 6-2 General Structure of Input Port

6.1.1 General Register Description

The individual control and data bits of each parallel port are implemented in a number of 8-bit registers. Bits with the same meaning and function are assembled together in the same register. The registers configure and use the port as general purpose I/O or alternate function input/output.

For port P2, not all the registers in [Table 6-1](#) are implemented. The availability and definition of registers specific to each port is defined in [Section 6.3](#) to [Section 6.6](#). This section provides only an overview of the different port registers.

Table 6-1 Port Registers

Register Short Name	Register Full Name	Description see
Px_DATA	Port x Data Register	Page 6-6
Px_DIR	Port x Direction Register	Page 6-7
Px_OD	Port x Open Drain Control Register	Page 6-7
Px_PUDSEL	Port x Pull-Up/Pull-Down Select Register	Page 6-8
Px_PUDEN	Port x Pull-Up/Pull-Down Enable Register	Page 6-8
Px_ALTSEL0	Port x Alternate Select Register 0	Page 6-10
Px_ALTSEL1	Port x Alternate Select Register 1	Page 6-10

6.1.1.1 Data Register

If a port pin is used as general purpose output, output data is written into the data register Px_DATA. If a port pin is used as general purpose input, the latched value of the port pin can be read through register Px_DATA.

Note: A port pin that has been assigned as input will latch in the active internal pull-up/pull-down setting if it is not driven by an external source. This results in register Px_DATA being updated with the active pull value.

Px_DATA Port x Data Register

7	6	5	4	3	2	1	0
P7	P6	P5	P4	P3	P2	P1	P0
rw	rw	rw	rw	rw	rw	rw	rw

Field	Bits	Type	Description
Pn (n = 0 – 7)	n	rw	Port x Pin n Data Value 0 Port x pin n data value = 0 1 Port x pin n data value = 1

Bit Px_DATA.n can only be written if the corresponding pin is set to output (Px_DIR.n = 1) and cannot be written if the corresponding pin is set to input (Px_DIR.n = 0). The content of Px_DATA.n is output on the assigned pin if the pin is assigned as GPIO pin and the direction is switched/set to output. A read operation of Px_DATA returns the register value and not the state of the corresponding Px_DATA pin.

6.1.1.2 Direction Register

The direction of port pins is controlled by the respective direction register Px_DIR.

Px_DIR

Port x Direction Register

7	6	5	4	3	2	1	0
P7	P6	P5	P4	P3	P2	P1	P0
rw	rw	rw	rw	rw	rw	rw	rw

Field	Bits	Type	Description
Pn (n = 0 – 7)	n	rw	Port x Pin n Direction Control 0 Direction is set to input. 1 Direction is set to output.

6.1.1.3 Open Drain Control Register

Each pin in output mode can be switched to open drain mode. If driven with 1, no driver will be activated and the pin output state depends on the internal pull-up/pull-down device setting. If driven with 0, the driver's pull-down transistor will be activated.

The open drain mode is controlled by the register Px_OD.

Px_OD

Port x Open Drain Control Register

7	6	5	4	3	2	1	0
P7	P6	P5	P4	P3	P2	P1	P0
rw	rw	rw	rw	rw	rw	rw	rw

Field	Bits	Type	Description
Pn (n = 0 – 7)	n	rw	Port x Pin n Open Drain Mode 0 Normal mode; output is actively driven for 0 and 1 state 1 Open drain mode; output is actively driven only for 0 state

6.1.1.4 Pull-Up/Pull-Down Device Register

Internal pull-up/pull-down devices can be optionally applied to a port pin. This offers the possibility of configuring the following input characteristics:

- tristate
- high-impedance with a weak pull-up device
- high-impedance with a weak pull-down device

and the following output characteristics:

- push/pull (optional pull-up/pull-down)
- open drain with internal pull-up
- open drain with external pull-up

The pull-up/pull-down device can be fixed or controlled via the registers Px_PUDSEL and Px_PUDEN. Register Px_PUDSEL selects the type of pull-up/pull-down device, while register Px_PUDEN enables or disables it. The pull-up/pull-down device can be selected pinwise.

Px_PUDSEL

Port x Pull-Up/Pull-Down Select Register

7	6	5	4	3	2	1	0
P7	P6	P5	P4	P3	P2	P1	P0
rw	rw	rw	rw	rw	rw	rw	rw

Field	Bits	Type	Description
Pn (n = 0 – 7)	n	rw	Pull-Up/Pull-Down Select Port x Bit n 0 Pull-down device is selected. 1 Pull-up device is selected.

Px_PUDEN

Port x Pull-Up/Pull-Down Enable Register

7	6	5	4	3	2	1	0
P7	P6	P5	P4	P3	P2	P1	P0
rw	rw	rw	rw	rw	rw	rw	rw

Parallel Ports

Field	Bits	Type	Description
Pn (n = 0 – 7)	n	rw	Pull-Up/Pull-Down Enable at Port x Bit n 0 Pull-up or Pull-down device is disabled. 1 Pull-up or Pull-down device is enabled.

6.1.1.5 Alternate Input Functions

The number of alternate functions that uses a pin for input is not limited. Each port control logic of an I/O pin provides several input paths:

- Digital input value via register
- Direct digital input value

6.1.1.6 Alternate Output Functions

Alternate functions are selected via an output multiplexer. This multiplexer can be controlled by the following registers:

- Register Px_ALTSEL0
- Register Px_ALTSEL1

Selection of alternate functions is defined in registers Px_ALTSEL0 and Px_ALTSEL1.

Px_ALTSELn (n = 0 - 1)

Port x Alternate Select Register

7	6	5	4	3	2	1	0
P7	P6	P5	P4	P3	P2	P1	P0
rw	rw	rw	rw	rw	rw	rw	rw

Function of Bits Px_ALTSEL0.Pn and Px_ALTSEL1.Pn

Px_ALTSEL0.Pn	Px_ALTSEL1.Pn	Function
0	0	Normal GPIO
1	0	Alternate Output 1
0	1	Alternate Output 2
1	1	Reserved

Note: Set Px_ALTSEL0.Pn and Px_ALTSEL1.Pn to select only implemented alternate output functions.

6.2 Register Map

The Port SFRs are located in the standard memory area (RMAP = 0) and are organized into 4 pages. The PORT_PAGE register is located at address B2_H. It contains the page value and page control information.

PORT_PAGE

Page Register for PORT

Reset Value: 00_H

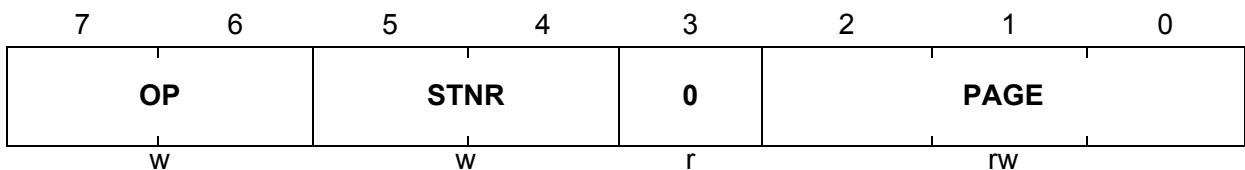

Field	Bits	Type	Description
PAGE	[2:0]	rw	<p>Page Bits</p> <p>When written, the value indicates the new page. When read, the value indicates the currently active page.</p>
STNR	[5:4]	w	<p>Storage Number</p> <p>This number indicates which storage bit field is the target of the operation defined by bit field OP. If OP = 10_B, the contents of PAGE are saved in STx before being overwritten with the new value. If OP = 11_B, the contents of PAGE are overwritten by the contents of STx. The value written to the bit positions of PAGE is ignored.</p> <p>00 ST0 is selected. 01 ST1 is selected. 10 ST2 is selected. 11 ST3 is selected.</p>

Parallel Ports

Field	Bits	Type	Description
OP	[7:6]	w	<p>Operation</p> <p>0X Manual page mode. The value of STNR is ignored and PAGE is directly written.</p> <p>10 New page programming with automatic page saving. The value written to the bit positions of PAGE is stored. In parallel, the previous contents of PAGE are saved in the storage bit field STx indicated by STNR.</p> <p>11 Automatic restore page action. The value written to the bit positions PAGE is ignored and instead, PAGE is overwritten by the contents of the storage bit field STx indicated by STNR.</p>
0	3	r	<p>Reserved</p> <p>Returns 0 if read; should be written with 0.</p>

The addresses of the Port SFRs are listed in [Table 6-2](#).

Table 6-2 SFR Address List for Pages 0-3

Address	Page 0	Page 1	Page 2	Page 3
80 _H	P0_DATA	P0_PUDSEL	P0_ALTSEL0	P0_OD
86 _H	P0_DIR	P0_PUDEN	P0_ALTSEL1	–
90 _H	P1_DATA	P1_PUDSEL	P1_ALTSEL0	P1_OD
91 _H	P1_DIR	P1_PUDEN	P1_ALTSEL1	–
A0 _H	P2_DATA	P2_PUDSEL	–	–
A1 _H	–	P2_PUDEN	–	–
B0 _H	P3_DATA	P3_PUDSEL	P3_ALTSEL0	P3_OD
B1 _H	P3_DIR	P3_PUDEN	P3_ALTSEL1	–

6.3 Port 0

Port P0 is a 6-bit general purpose bidirectional port. The registers of P0 are summarized in [Table 6-3](#).

Table 6-3 Port 0 Registers

Register Short Name	Register Full Name
P0_DATA	Port 0 Data Register
P0_DIR	Port 0 Direction Register
P0_OD	Port 0 Open Drain Control Register
P0_PUDSEL	Port 0 Pull-Up/Pull-Down Select Register
P0_PUDEN	Port 0 Pull-Up/Pull-Down Enable Register
P0_ALTSEL0	Port 0 Alternate Select Register 0
P0_ALTSEL1	Port 0 Alternate Select Register 1

6.3.1 Functions

Table 6-4 Port 0 Input/Output Functions

Port Pin	Input/Output	Select	Connected Signal(s)	From/to Module
P0.0	Input	GPI	P0_DATA.P0	–
		ALT1	TCK_0	JTAG
		ALT2	T12HR_1	CCU6
		ALT3	CC61_1	CCU6
	Output	GPO	P0_DATA.P0	–
		ALT1	CLKOUT	On-chip OSC
ALT2		CC61_1	CCU6	
P0.1	Input	GPI	P0_DATA.P1	–
		ALT1	TDI_0	JTAG
		ALT2	T13HR_1	CCU6
		ALT3	RXD_1	UART
	Output	GPO	P0_DATA.P1	–
		ALT1	–	–
ALT2		COUT61_1	CCU6	

Table 6-4 Port 0 Input/Output Functions (cont'd)

Port Pin	Input/Output	Select	Connected Signal(s)	From/to Module
P0.2	Input	GPI	P0_DATA.P2	–
		ALT1	–	–
		ALT2	CTRAP_2	CCU6
		ALT3	–	–
	Output	GPO	P0_DATA.P2	–
		ALT1	TDO_0	JTAG
ALT2		TXD_1	UART	
P0.3	Input	GPI	P0_DATA.P3	–
		ALT1	SCK_1	SSC
		ALT2	–	–
		ALT3	–	–
	Output	GPO	P0_DATA.P3	–
		ALT1	SCK_1	SSC
ALT2		COOUT63_1	CCU6	
P0.4	Input	GPI	P0_DATA.P4	–
		ALT1	MTSR_1	SSC
		ALT2	–	–
		ALT3	CC62_1	CCU6
	Output	GPO	P0_DATA.P4	–
		ALT1	MTSR_1	SSC
ALT2		CC62_1	CCU6	
P0.5	Input	GPI	P0_DATA.P5	–
		ALT1	MRST_1	SSC
		ALT2	EXINT0_0	External interrupt 0
		ALT3	–	–
	Output	GPO	P0_DATA.P5	–
		ALT1	MRST_1	SSC
ALT2		COOUT62_1	CCU6	

6.3.2 Register Description

P0_DATA

Port 0 Data Register

Reset Value: 00_H

7	6	5	4	3	2	1	0
0	P5	P4	P3	P2	P1	P0	
r	rw	rw	rw	rw	rw	rw	rw

Field	Bits	Type	Description
Pn (n = 0 – 5)	n	rw	Port 0 Pin n Data Value 0 Port 0 pin n data value = 0 (default) 1 Port 0 pin n data value = 1
0	[7:6]	r	Reserved Returns 0 if read; should be written with 0.

P0_DIR

Port 0 Direction Register

Reset Value: 00_H

7	6	5	4	3	2	1	0
0	P5	P4	P3	P2	P1	P0	
r	rw	rw	rw	rw	rw	rw	rw

Field	Bits	Type	Description
Pn (n = 0 – 5)	n	rw	Port 0 Pin n Direction Control 0 Direction is set to input (default). 1 Direction is set to output.
0	[7:6]	r	Reserved Returns 0 if read; should be written with 0.

P0_OD

Port 0 Open Drain Control Register

Reset Value: 00_H

7	6	5	4	3	2	1	0
0	P5	P4	P3	P2	P1	P0	
r	rw	rw	rw	rw	rw	rw	rw

Field	Bits	Type	Description
Pn (n = 0 – 5)	n	rw	Port 0 Pin n Open Drain Mode 0 Normal mode; output is actively driven for 0 and 1 state (default) 1 Open drain mode; output is actively driven only for 0 state
0	[7:6]	r	Reserved Returns 0 if read; should be written with 0.

P0_PUDSEL

Port 0 Pull-Up/Pull-Down Select Register

Reset Value: FF_H

7	6	5	4	3	2	1	0
0	P5	P4	P3	P2	P1	P0	
r	rw	rw	rw	rw	rw	rw	rw

Field	Bits	Type	Description
Pn (n = 0 – 5)	n	rw	Pull-Up/Pull-Down Select Port 0 Bit n 0 Pull-down device is selected. 1 Pull-up device is selected (default).
0	[7:6]	r	Reserved Returns 0 if read; should be written with 0.

P0_PUDEN

Port 0 Pull-Up/Pull-Down Enable Register

Reset Value: C4_H

7	6	5	4	3	2	1	0
0	P5	P4	P3	P2	P1	P0	
r	rw	rw	rw	rw	rw	rw	rw

Field	Bits	Type	Description
Pn (n = 0 – 5)	n	rw	Pull-Up/Pull-Down Enable at Port 0 Bit n 0 Pull-up or Pull-down device is disabled. 1 Pull-up or Pull-down device is enabled (default).
0	[7:6]	r	Reserved Returns 0 if read; should be written with 0.

P0_ALTSELn (n = 0 – 1)

Port 0 Alternate Select Register

Reset Value: 00_H

7	6	5	4	3	2	1	0
0	P5	P4	P3	P2	P1	P0	
r	rw	rw	rw	rw	rw	rw	rw

Table 6-5 Function of Bits P0_ALTSEL0.Pn and P0_ALTSEL1.Pn

P0_ALTSEL0.Pn	P0_ALTSEL1.Pn	Function
0	0	Normal GPIO
1	0	Alternate Output 1
0	1	Alternate Output 2
1	1	Reserved

6.4 Port 1

Port P1 is a 5-bit general purpose bidirectional port. The registers of P1 are summarized in [Table 6-6](#).

Table 6-6 Port 1 Registers

Register Short Name	Register Full Name
P1_DATA	Port 1 Data Register
P1_DIR	Port 1 Direction Register
P1_OD	Port 1 Open Drain Control Register
P1_PUDSEL	Port 1 Pull-Up/Pull-Down Select Register
P1_PUDEN	Port 1 Pull-Up/Pull-Down Enable Register
P1_ALTSEL0	Port 1 Alternate Select Register 0
P1_ALTSEL1	Port 1 Alternate Select Register 1

6.4.1 Functions

Table 6-7 Port 1 Input/Output Functions

Port Pin	Input/Output	Select	Connected Signal(s)	From/to Module
P1.0	Input	GPI	P1_DATA.P0	–
		ALT 1	RXD_0	UART
		ALT 2	T2EX	Timer 2
		ALT 3	–	–
	Output	GPO	P1_DATA.P0	–
		ALT1	–	–
ALT2		–	–	
P1.1	Input	GPI	P1_DATA.P1	–
		ALT 1	–	–
		ALT 2	EXINT3	External interrupt 3
		ALT 3	–	–
	Output	GPO	P1_DATA.P1	–
		ALT1	TDO_1	JTAG
ALT2		TXD_0	UART	

Table 6-7 Port 1 Input/Output Functions (cont'd)

Port Pin	Input/Output	Select	Connected Signal(s)	From/to Module
P1.5	Input	GPI	P1_DATA.P5	–
		ALT 1	CCPOS0_1	CCU6
		ALT 2	EXINT5	External interrupt 5
		ALT 3	–	–
	Output	GPO	P1_DATA.P5 ¹⁾	–
		ALT1	–	–
		ALT2	–	–
P1.6	Input	GPI	P1_DATA.P6	–
		ALT 1	CCPOS1_1	CCU6
		ALT 2	T12HR_0	CCU6
		ALT 3	EXINT6	External interrupt 6
	Output	GPO	P1_DATA.P6 ²⁾	–
		ALT1	–	–
		ALT2	–	–
P1.7	Input	GPI	P1_DATA.P7	–
		ALT 1	CCPOS2_1	CCU6
		ALT 2	T13HR_0	CCU6
		ALT 3	–	–
	Output	GPO	P1_DATA.P7	–
		ALT1	–	–
		ALT2	–	–

1) P1.5 can be used as a software Chip Select function for the SSC.

2) P1.6 can be used as a software Chip Select function for the SSC.

6.4.2 Register Description

P1_DATA

Port 1 Data Register

Reset Value: 00_H

7	6	5	4	3	2	1	0
P7	P6	P5	0			P1	P0
rw	rw	rw	r			rw	rw

Field	Bits	Type	Description
Pn (n = 0 – 1, 5 – 7)	n	rw	Port 1 Pin n Data Value 0 Port 1 pin n data value = 0 (default) 1 Port 1 pin n data value = 1
0	[4:2]	r	Reserved Returns 0 if read; should be written with 0.

P1_DIR

Port 1 Direction Register

Reset Value: 00_H

7	6	5	4	3	2	1	0
P7	P6	P5	0			P1	P0
rw	rw	rw	r			rw	rw

Field	Bits	Type	Description
Pn (n = 0 – 1, 5 – 7)	n	rw	Port 1 Pin n Direction Control 0 Direction is set to input (default). 1 Direction is set to output.
0	[4:2]	r	Reserved Returns 0 if read; should be written with 0.

P1_OD

Port 1 Open Drain Control Register

Reset Value: 00_H

7	6	5	4	3	2	1	0
P7	P6	P5	0			P1	P0
rw	rw	rw	r			rw	rw

Field	Bits	Type	Description
Pn (n = 0 – 1, 5 – 7)	n	rw	Port 1 Pin n Open Drain Mode 0 Normal mode; output is actively driven for 0 and 1 state (default) 1 Open drain mode; output is actively driven only for 0 state
0	[4:2]	r	Reserved Returns 0 if read; should be written with 0.

P1_PUDSEL

Port 1 Pull-Up/Pull-Down Select Register

Reset Value: FF_H

7	6	5	4	3	2	1	0
P7	P6	P5	0			P1	P0
rw	rw	rw	r			rw	rw

Field	Bits	Type	Description
Pn (n = 0 – 1, 5 – 7)	n	rw	Pull-Up/Pull-Down Select Port 1 Bit n 0 Pull-down device is selected. 1 Pull-up device is selected (default).
0	[4:2]	r	Reserved Returns 0 if read; should be written with 0.

P1_PUDEN

Port 1 Pull-Up/Pull-Down Enable Register

Reset Value: FF_H

7	6	5	4	3	2	1	0
P7	P6	P5	0			P1	P0
rw	rw	rw	r			rw	rw

Field	Bits	Type	Description
Pn (n = 0 – 1, 5 – 7)	n	rw	Pull-Up/Pull-Down Enable at Port 1 Bit n 0 Pull-up or Pull-down device is disabled. 1 Pull-up or Pull-down device is enabled (default).
0	[4:2]	r	Reserved Returns 0 if read; should be written with 0.

P1_ALTSELn (n = 0 – 1)

Port 1 Alternate Select Register

Reset Value: 00_H

7	6	5	4	3	2	1	0
P7	P6	P5	0			P1	P0
rw	rw	rw	r			rw	rw

Table 6-8 Function of Bits P1_ALTSEL0.Pn and P1_ALTSEL1.Pn

P1_ALTSEL0.Pn	P1_ALTSEL1.Pn	Function
0	0	Normal GPIO
1	0	Alternate Output 1
0	1	Alternate Output 2
1	1	Reserved

6.5 Port 2

Port P2 is an 8-bit general purpose input-only port. The registers of P2 are summarized in [Table 6-9](#).

Table 6-9 Port 2 Registers

Register Short Name	Register Full Name
P2_DATA	Port 2 Data Register
P2_PUDSEL	Port 2 Pull-Up/Pull-Down Select Register
P2_PUDEN	Port 2 Pull-Up/Pull-Down Enable Register

6.5.1 Functions

Table 6-10 Port 2 Input Functions

Port Pin	Input/Output	Select	Connected Signal(s)	From/to Module
P2.0	Input	GPI	P2_DATA.P0	–
		ALT 1	CCPOS0_0	CCU6
		ALT 2	EXINT1	External interrupt 1
		ALT 3	T12HR_2	CCU6
		ALT 4	TCK_1	JTAG
		ANALOG	AN0	ADC
P2.1	Input	GPI	P2_DATA.P1	–
		ALT 1	CCPOS1_0	CCU6
		ALT 2	EXINT2	External interrupt 2
		ALT 3	T13HR_2	CCU6
		ALT 4	TDI_1	JTAG
		ANALOG	AN1	ADC
P2.2	Input	GPI	P2_DATA.P2	–
		ALT 1	CCPOS2_0	CCU6
		ALT 2	–	–
		ALT 3	CTR \overline AP_1	CCU6
		ALT 4	–	–
		ANALOG	AN2	ADC

Table 6-10 Port 2 Input Functions (cont'd)

Port Pin	Input/Output	Select	Connected Signal(s)	From/to Module
P2.3	Input	GPI	P2_DATA.P3	–
		ALT 1	–	–
		ALT 2	–	–
		ALT 3	–	–
		ANALOG	AN3	ADC
P2.4	Input	GPI	P2_DATA.P4	–
		ALT 1	–	–
		ALT 2	–	–
		ALT 3	–	–
		ANALOG	AN4	ADC
P2.5	Input	GPI	P2_DATA.P5	–
		ALT 1	–	–
		ALT 2	–	–
		ALT 3	–	–
		ANALOG	AN5	ADC
P2.6	Input	GPI	P2_DATA.P6	–
		ALT 1	–	–
		ALT 2	–	–
		ALT 3	–	–
		ANALOG	AN6	ADC
P2.7	Input	GPI	P2_DATA.P7	–
		ALT 1	–	–
		ALT 2	–	–
		ALT 3	–	–
		ANALOG	AN7	ADC

6.5.2 Register Description

P2_DATA

Port 2 Data Register

Reset Value: 00_H

7	6	5	4	3	2	1	0
P7	P6	P5	P4	P3	P2	P1	P0
r	r	r	r	r	r	r	r

Field	Bits	Type	Description
Pn (n = 0 – 7)	n	r	Port 2 Pin n Data Value 0 Port 2 pin n data value = 0 (default) 1 Port 2 pin n data value = 1

P2_PUDSEL

Port 2 Pull-Up/Pull-Down Select Register

Reset Value: FF_H

7	6	5	4	3	2	1	0
P7	P6	P5	P4	P3	P2	P1	P0
rw	rw	rw	rw	rw	rw	rw	rw

Field	Bits	Type	Description
Pn (n = 0 – 7)	n	rw	Pull-Up/Pull-Down Select Port 2 Bit n 0 Pull-down device is selected. 1 Pull-up device is selected.

P2_PUDEN

Port 2 Pull-Up/Pull-Down Enable Register

Reset Value: 00_H

7	6	5	4	3	2	1	0
P7	P6	P5	P4	P3	P2	P1	P0
rw	rw	rw	rw	rw	rw	rw	rw

Field	Bits	Type	Description
Pn (n = 0 – 7)	n	rw	Pull-Up/Pull-Down Enable at Port 2 Bit n 0 Pull-up or Pull-down device is disabled (default). 1 Pull-up or Pull-down device is enabled.

6.6 Port 3

Port P3 is an 8-bit general purpose bidirectional port. The registers of P3 are summarized in [Table 6-11](#).

Table 6-11 Port 3 Registers

Register Short Name	Register Full Name
P3_DATA	Port 3 Data Register
P3_DIR	Port 3 Direction Register
P3_OD	Port 3 Open Drain Control Register
P3_PUDSEL	Port 3 Pull-Up/Pull-Down Select Register
P3_PUDEN	Port 3 Pull-Up/Pull-Down Enable Register
P3_ALTSEL0	Port 3 Alternate Select Register 0
P3_ALTSEL1	Port 3 Alternate Select Register 1

6.6.1 Functions

Table 6-12 Port 3 Input/Output Functions

Port Pin	Input/Output	Select	Connected Signal(s)	From/to Module
P3.0	Input	GPI	P3_DATA.P0	–
		ALT 1	CC60_0	CCU6
		ALT 2	–	–
		ALT 3	–	–
	Output	GPO	P3_DATA.P0	–
		ALT1	CC60_0	CCU6
ALT2		–	–	
P3.1	Input	GPI	P3_DATA.P1	–
		ALT 1	–	–
		ALT 2	–	–
		ALT 3	–	–
	Output	GPO	P3_DATA.P1	–
		ALT1	COUT60_0	CCU6
ALT2		–	–	

Table 6-12 Port 3 Input/Output Functions (cont'd)

Port Pin	Input/Output	Select	Connected Signal(s)	From/to Module
P3.2	Input	GPI	P3_DATA.P2	–
		ALT 1	CC61_0	CCU6
		ALT 2	–	–
		ALT 3	–	–
	Output	GPO	P3_DATA.P3	–
		ALT1	CC61_0	CCU6
ALT2		–	–	
P3.3	Input	GPI	P3_DATA.P3	–
		ALT 1	–	–
		ALT 2	–	–
		ALT 3	–	–
	Output	GPO	P3_DATA.P3	–
		ALT1	COU61_0	CCU6
ALT2		–	–	
P3.4	Input	GPI	P3_DATA.P4	–
		ALT 1	CC62_0	CCU6
		ALT 2	–	–
		ALT 3	–	–
	Output	GPO	P3_DATA.P4	–
		ALT1	CC62_0	CCU6
ALT2		–	–	
P3.5	Input	GPI	P3_DATA.P5	–
		ALT 1	–	–
		ALT 2	–	–
		ALT 3	–	–
	Output	GPO	P3_DATA.P5	–
		ALT1	COU62_0	CCU6
ALT2		–	–	

Table 6-12 Port 3 Input/Output Functions (cont'd)

Port Pin	Input/Output	Select	Connected Signal(s)	From/to Module
P3.6	Input	GPI	P3_DATA.P6	–
		ALT 1	CTRAP_0	CCU6
		ALT 2	–	–
		ALT 3	–	–
	Output	GPO	P3_DATA.P6	–
		ALT1	–	–
ALT2		RSTOUT	Internal reset	
P3.7	Input	GPI	P3_DATA.P7	–
		ALT 1	–	–
		ALT 2	EXINT4	External interrupt 4
		ALT 3	–	–
	Output	GPO	P3_DATA.P7	–
		ALT1	COU63	CCU6
ALT2		–	–	

6.6.2 Register Description

P3_DATA

Port 3 Data Register

Reset Value: 00_H

7	6	5	4	3	2	1	0
P7	P6	P5	P4	P3	P2	P1	P0
rw	rw	rw	rw	rw	rw	rw	rw

Field	Bits	Type	Description
Pn (n = 0 – 7)	n	rw	Port 3 Pin n Data Value 0 Port 3 pin n data value = 0 (default) 1 Port 3 pin n data value = 1

P3_DIR

Port 3 Direction Register

Reset Value: 00_H

7	6	5	4	3	2	1	0
P7	P6	P5	P4	P3	P2	P1	P0
rw	rw	rw	rw	rw	rw	rw	rw

Field	Bits	Type	Description
Pn (n = 0 – 7)	n	rw	Port 3 Pin n Direction Control 0 Direction is set to input (default). 1 Direction is set to output.

P3_OD

Port 3 Open Drain Control Register

Reset Value: 00_H

7	6	5	4	3	2	1	0
P7	P6	P5	P4	P3	P2	P1	P0
rw	rw	rw	rw	rw	rw	rw	rw

Field	Bits	Type	Description
Pn (n = 0 – 7)	n	rw	Port 3 Pin n Open Drain Mode 0 Normal mode; output is actively driven for 0 and 1 state (default) 1 Open drain mode; output is actively driven only for 0 state

P3_PUDSEL

Port 3 Pull-Up/Pull-Down Select Register

Reset Value: BF_H

7	6	5	4	3	2	1	0
P7	P6	P5	P4	P3	P2	P1	P0
rw	rw	rw	rw	rw	rw	rw	rw

Field	Bits	Type	Description
Pn (n = 0 – 7)	n	rw	Pull-Up/Pull-Down Select Port 3 Bit n 0 Pull-down device is selected. 1 Pull-up device is selected.

P3_PUDEN

Port 3 Pull-Up/Pull-Down Enable Register

Reset Value: 40_H

7	6	5	4	3	2	1	0
P7	P6	P5	P4	P3	P2	P1	P0
rw	rw	rw	rw	rw	rw	rw	rw

Field	Bits	Type	Description
Pn (n = 0 – 7)	n	rw	Pull-Up/Pull-Down Enable at Port 3 Bit n 0 Pull-up or Pull-down device is disabled. 1 Pull-up or Pull-down device is enabled.

P3_ALTSELn (n = 0 – 1)

Port 3 Alternate Select Register

Reset Value: 00_H

7	6	5	4	3	2	1	0
P7	P6	P5	P4	P3	P2	P1	P0
rw	rw	rw	rw	rw	rw	rw	rw

Table 6-13 Function of Bits P3_ALTSEL0.Pn and P3_ALTSEL1.Pn

P3_ALTSEL0.Pn	P3_ALTSEL1.Pn	Function
0	0	Normal GPIO
1	0	Alternate Output 1
0	1	Alternate Output 2
1	1	Reserved

7 Power Supply, Reset and Clock Management

The XC866 provides a range of utility features for secure system performance under critical conditions (e.g., brownout).

The power supply to the core, memories and the peripherals is regulated by the Embedded Voltage Regulator (EVR), with detection circuitries to ensure that the supplied voltages are within the specified operating range. The main voltage and low power voltage regulators in the EVR may be independently switched off to reduce power consumption for the different power saving modes.

At the center of the XC866 clock system is the Clock Generation Unit (CGU), which generates a master clock frequency using the Phase-Locked Loop (PLL) and oscillator units. In-phase synchronized clock signals are derived from the master clock and distributed throughout the system. A programmable clock divider is available for scaling the master clock into lower frequencies for power savings.

7.1 Power Supply System with Embedded Voltage Regulator

The XC866 microcontroller requires two different levels of power supply:

- 3.3 V or 5.0 V for the Embedded Voltage Regulator (EVR) and Ports
- 2.5 V for the core, memory, on-chip oscillator, and peripherals

Figure 7-1 shows the XC866 power supply system. A power supply of 3.3 V or 5.0 V must be provided from the external power supply pin. The 2.5 V power supply for the logic is generated by the EVR. The EVR helps reduce the power consumption of the whole chip and the complexity of the application board design.

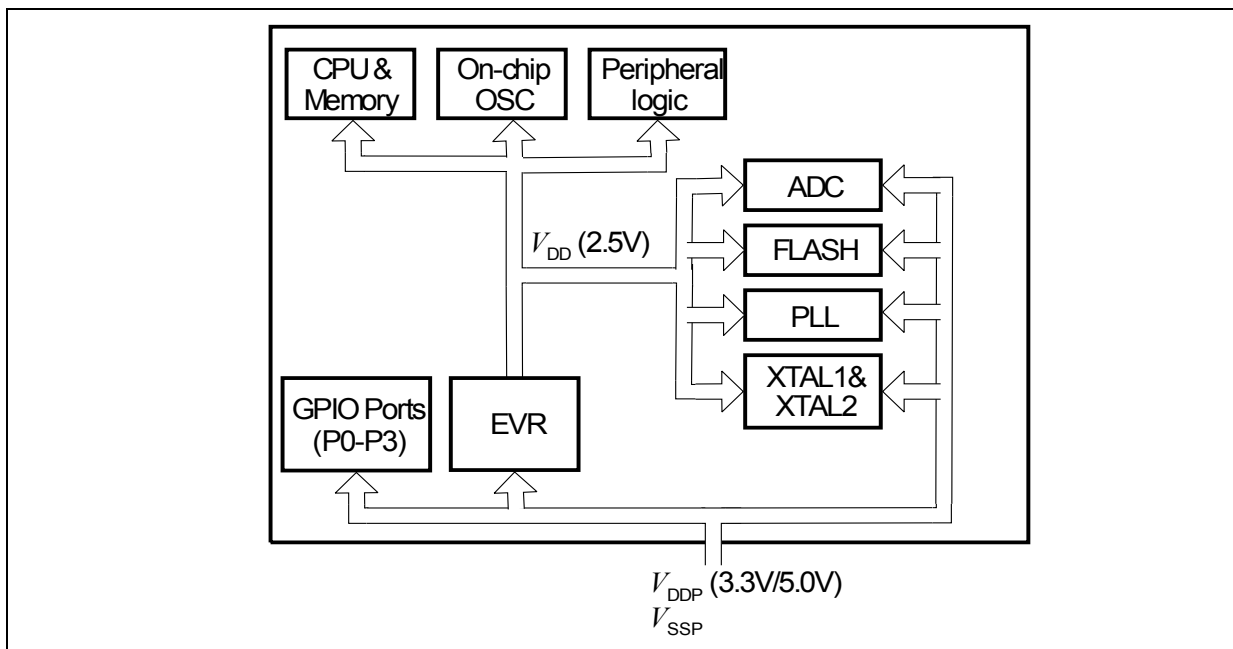

Figure 7-1 XC866 Power Supply System

EVR Features:

- Input voltage (V_{DDP}): 3.3 V/5.0 V
- Output voltage (V_{DD}): 2.5 V +/-7.5%
- Low power voltage regulator provided in power-down mode
- V_{DD} and V_{DDP} prewarning detection
- V_{DD} brownout detection

The EVR consists of a main voltage regulator and a low power voltage regulator. In active mode, both voltage regulators are enabled. In power-down mode, the main voltage regulator is switched off, while the low power voltage regulator continues to function and provide power supply to the system with low power consumption.

The EVR has the V_{DD} and V_{DDP} detectors. There are two threshold voltage levels for V_{DD} detection: prewarning (2.3 V) and brownout (2.1 V). When V_{DD} is below 2.3 V, the V_{DD} NMI flag `NMISR.FNMIVDD` is set and an NMI request to the CPU is activated if V_{DD} NMI is enabled (`NMICON.NMIVDD`). If V_{DD} is below 2.1 V, the brownout reset will be activated, putting the microcontroller into a reset state.

For V_{DDP} , there is only one prewarning threshold of 4.0 V if the external power supply is 5.0 V. When V_{DDP} is below 4.0 V, the V_{DDP} NMI flag `NMISR.FNMIVDDP` is set and an NMI request to the CPU is activated if V_{DDP} NMI is enabled (`NMICON.NMIVDDP`).

If an external power supply of 3.3 V is used, the user must disable V_{DDP} detector by clearing bit `NMICON.NMIVDDP`. In power-down mode, the V_{DD} detector is switched off and V_{DDP} detector will continue to function.

The EVR also has a power-on reset (POR) detector for V_{DD} to ensure correct power up. The voltage level detection of POR is 1.6 V. The monitoring function is used in both active mode and power-down mode. During power up, after V_{DD} exceeds 1.6 V, the reset of EVR is extended by a delay that is typically 300 μ s. In active mode, V_{DD} is monitored mainly by the V_{DD} detector, and a reset is generated when V_{DD} drops below 2.1 V. In power-down mode, the V_{DD} is monitored by the POR and a reset is generated when V_{DD} drops below 1.6 V.

7.2 Reset Control

The XC866 has five types of reset: power-on reset, hardware reset, watchdog timer reset, power-down wake-up reset, and brownout reset.

When the XC866 is first powered up, the status of certain pins (see [Table 7-2](#)) must be defined to ensure proper start operation of the device. At the end of a reset sequence, the sampled values are latched to select the desired boot option, which cannot be modified until the next power-on reset or hardware reset. This guarantees stable conditions during the normal operation of the device.

The hardware reset function can be used during normal operation or when the chip is in power-down mode. A reset input pin RESET is provided for the hardware reset.

The Watchdog Timer (WDT) module is also capable of resetting the device if it detects a malfunction in the system.

Another type of reset that needs to be detected is a reset while the device is in power-down mode (wake-up reset). While the contents of the static RAM are undefined after a power-on reset, they are well defined after a wake-up reset from power-down mode.

A brownout reset is triggered if the V_{DD} supply voltage dips below 2.1 V.

7.2.1 Types of Reset

7.2.1.1 Power-On Reset

The supply voltage V_{DDP} is used to power up the chip. The EVR is the first module in the chip to be reset, which includes:

1. Startup of the main voltage regulator and the low power voltage regulator.
2. When V_{DDP} and V_{DD} reach the threshold of the V_{DDP} and V_{DD} detectors, the reset of EVR becomes inactive.

When the system starts up, the PLL is disconnected from the oscillator and will run at its base frequency. Once the EVR is stable, provided the oscillator is running, the PLL is connected and the continuous lock detection ensures that PLL starts functioning. Following this, as soon as the system clock is stable, each 4-Kbyte Flash bank will enter the ready-to-read mode.

The status of pins MBC, TMS and P0.0 is latched by the reset. The latched values are used to select the boot options (see [Section 7.2.3](#)). A correctly executed reset leaves the system in a defined state. The program execution starts from location 0000_H.

[Figure 7-2](#) shows the power-on reset sequence.

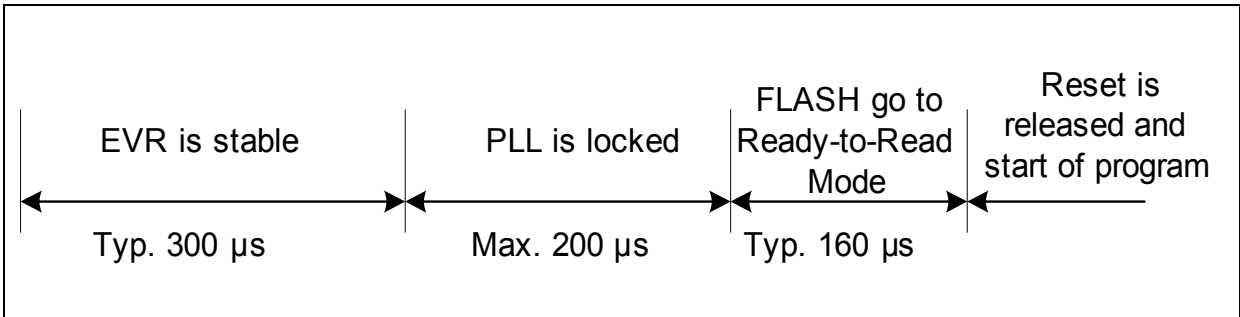

Figure 7-2 Power-on Reset

7.2.1.2 Hardware Reset

An external hardware reset sequence is started when the reset input pin $\overline{\text{RESET}}$ is asserted low. The $\overline{\text{RESET}}$ pin must be held low for at least 1ms. After the $\overline{\text{RESET}}$ pin is deasserted, the reset sequence is the same as the power-on reset sequence, as shown in Figure 7-2. A hardware reset through $\overline{\text{RESET}}$ pin will terminate the idle mode or the power-down mode.

The status of pins MBC, TMS and P0.0 is latched by the reset. The latched value is used to select the boot options (see Section 7.2.3).

7.2.1.3 Watchdog Timer Reset

The watchdog timer reset is an internal reset. The Watchdog Timer (WDT) maintains a counter that must be refreshed or cleared periodically. If the WDT is not serviced correctly and in time, it will generate an NMI request to the CPU and then reset the device after a predefined time-out period. Bit PMCON0.WDTRST is used to indicate the watchdog timer reset status.

For watchdog timer reset, as the EVR is already stable and PLL lock detection is not needed, the timing for watchdog timer reset is approximately 200 µs, which is shorter as compared to the other types of reset.

7.2.1.4 Power-Down Wake-Up Reset

Power is still applied to the XC866 during power-down mode, as the low power voltage regulator is still operating. If power-down mode is entered appropriately, all important system state will have been preserved in the Flash by software.

If the XC866 is in power-down mode, three options are available to awaken it:

- through RXD
- through EXINT0
- through RXD or EXINT0

Power Supply, Reset and Clock Management

Selection of these options is made via the control bit PMCON0.WS. The wake-up from power-down can be with reset or without reset; this is chosen by the PMCON0.WKSET bit. The wake-up status (with or without reset) is indicated by the PMCON0.WKRS bit.

Figure 7-3 shows the power-down wake-up reset sequence. The EVR takes approximately 150 μ s to become stable, which is a shorter time period as compared to the power-on reset.

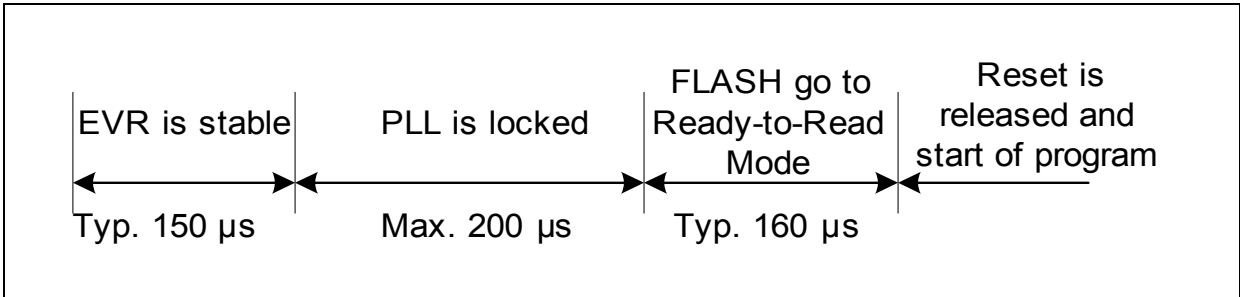

Figure 7-3 Power-down Wake-up Reset

In addition to the above-mentioned three options, the power-down mode can also be exited by the hardware reset through RESET pin.

7.2.1.5 Brownout Reset

In active mode, the V_{DD} detector in EVR detects brownout when the core supply voltage V_{DD} dips below the threshold voltage V_{DD_TH} (2.1 V). The brownout will cause the device to be reset. In power-down mode, the V_{DD} is monitored by the POR in EVR and a reset is generated when V_{DD} drops below 1.6 V.

Once the brownout reset takes place, the reset sequence is the same as the power-on reset sequence, as shown in **Figure 7-2**.

7.2.2 Module Reset Behavior

Table 7-1 shows how the functions of the XC866 are affected by the various reset types. A “■” means that this function is reset to its default state.

Table 7-1 Effect of Reset on Device Functions

Module/ Function	Wake-Up Reset	Watchdog Reset	Hardware Reset	Power-On Reset	Brownout Reset
CPU Core	■	■	■	■	■
Peripherals	■	■	■	■	■
On-Chip Static RAM	Not affected, reliable	Not affected, reliable	Not affected, reliable	Affected, un- reliable	Affected, un- reliable
Oscillator, PLL	■	Not affected	■	■	■
Port Pins	See Chapter 6 , “Parallel Ports”				
EVR	The voltage regulator is switched on	Not affected	■	■	■
FLASH	■	■	■	■	■
NMI	■	Disabled	Disabled	■	■

7.2.3 Booting Scheme

When the XC866 is reset, it must identify the type of configuration with which to start the different modes once the reset sequence is complete. Thus, boot configuration information that is required for activation of special modes and conditions needs to be applied by the external world through input pins. After power-on reset or hardware reset, the pins MBC, TMS and P0.0 collectively select the different boot options. **Table 7-2** shows the available boot options in the XC866.

Table 7-2 XC866 Boot Selections

MBC	TMS	P0.0	Type of Mode	PC Start Value
1	x	x	User Mode; OSC/PLL non-bypassed	0000 _H
0	0	x	BSL Mode; OSC/PLL non-bypassed	0000 _H
0	1	0	OCDS Mode; OSC/PLL non-bypassed	0000 _H

Power Supply, Reset and Clock Management

7.2.4 Register Description

PMCON0

Power Mode Control Register 0

Reset Value: See [Table 7-3](#)

7	6	5	4	3	2	1	0
0	WDTRST	WKRS	WKSEL	SD	PD	WS	
r	rwh	rwh	rw	rw	rwh	rw	



The functions of the shaded bits are not described here

Field	Bits	Type	Description
WS	[1:0]	rw	Wake-Up Source Select 00 No wake-up is selected. 01 Wake-up source RXD is selected. 10 Wake-up source EXINT0 is selected. 11 Wake-up source RXD or EXINT0 is selected.
WKSEL	4	rw	Wake-Up Reset Select Bit 0 Wake-up without reset 1 Wake-up with reset
WKRS	5	rwh	Wake-Up Indication Bit 0 No wake-up occurred. 1 Wake-up has occurred. This bit can only be set by hardware and reset by software.
WDTRST	6	rwh	Watchdog Timer Reset Indication Bit 0 No watchdog timer reset occurred. 1 Watchdog timer reset has occurred. This bit can only be set by hardware and reset by software.
0	7	r	Reserved Returns 0 if read; should be written with 0.

Power Supply, Reset and Clock Management**Table 7-3 Reset Values of Register PMCON0**

Reset Source	Reset Value
Power-on Reset/Hardware Reset/Brownout Reset	0000 0000 _B
Watchdog Timer Reset	0100 0000 _B
Power-down Wake-up Reset	0010 0000 _B

7.3 Clock System

The XC866 clock system performs the following functions:

- Acquires and buffers incoming clock signals to create a master clock frequency
- Distributes in-phase synchronized clock signals throughout the system
- Divides a system master clock frequency into lower frequencies for power saving mode

7.3.1 Clock Generation Unit

The Clock Generation Unit (CGU) in the XC866 consists of an oscillator circuit and a Phase-Locked Loop (PLL). In the XC866, the oscillator can be from either of these two sources: the on-chip oscillator (10 MHz) or the external oscillator (3 MHz to 12 MHz). The term “oscillator” is used to refer to both on-chip oscillator and external oscillator, unless otherwise stated. After the reset, the on-chip oscillator will be used by default. The external oscillator can be selected via software. The PLL can convert a low-frequency external clock signal from the oscillator circuit to a high-speed internal clock for maximum performance.

Figure 7-4 shows the block diagram of CGU.

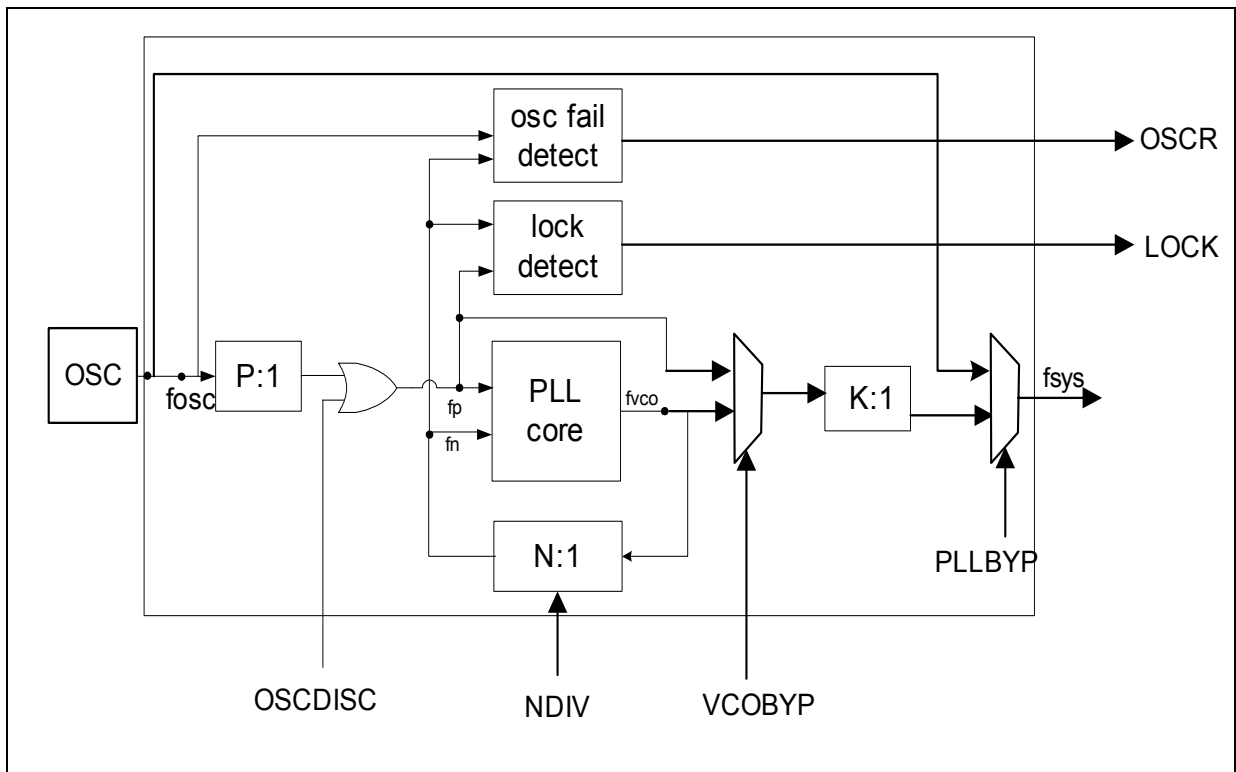

Figure 7-4 CGU Block Diagram

7.3.1.1 Functional Description

When the XC866 is powered up, the PLL is disconnected from the oscillator and will run at its VCO base frequency. After the EVR is stable, provided the oscillator is running, the PLL will be connected and the continuous lock detection will ensure that the PLL starts functioning. Once reset has been released, bit OSCR will be set to 1 if the oscillator is running and bit LOCK will be set to 1 if the PLL is locked.

Loss-of-Lock Operation

If the PLL is not the system's clock source ($VCOBYP = 1$) when the loss of lock is detected, only the lock flag is reset ($PLL_CON.LOCK = 0$) and no further action is taken. This allows the PLL parameters to be switched dynamically.

If PLL loses its lock to the oscillator, the PLL Loss-of-Lock NMI flag $NMISR.FNMIPLL$ is set and an NMI request to the CPU is activated if PLL NMI is enabled ($NMICON.NMIPLL$). In addition, the LOCK flag in PLL_CON is reset. PLL VCO gradually slows down to its base frequency. Emergency routines can be executed with the XC866 clocked with this base frequency.

The XC866 remains in this loss-of-lock state until the next power-on reset, hardware reset or after a successful lock recovery has been performed.

Loss-of-Lock Recovery

If PLL has lost its lock to the oscillator, the PLL can be re-locked by software. The following sequence must be performed:

1. Disconnect the oscillator from the PLL ($OSCDISC = 1$).
2. Set the N-divider of the PLL to the value 16 ($PLL_CON.NDIV = 0010_B$).
3. Wait for 50 μs until the oscillator is stable.
4. Restart the Oscillator Run Detection by setting bit $OSC_CON.ORDRES$.

If bit $OSC_CON.OSCR$ is set, then:

1. Select the VCO bypass mode ($VCOBYP = 1$).
2. Reconnect oscillator to the PLL ($OSCDISC = 0$).
3. Reprogram the $NDIV$ factor to the original value.
4. The $RESLD$ bit must be set and the LOCK flag checked. Only if the LOCK flag is set again can the VCO bypass mode be deselected and normal operation resumed.

If neither OSCR nor LOCK is set, emergency measures must be executed. Emergency measures such as a system shut down can be carried out by the user.

Changing PLL Parameters

To change the PLL parameters, first check if the oscillator is running (`OSC_CON.OSCR = 1`). In this case:

1. Select VCO bypass mode (`VCOBYP = 1`).
2. Connect oscillator to PLL (`OSCDISC = 0`).
3. Program desired `NDIV` value.
4. Wait till the `LOCK` bit has been set.
5. Disable VCO bypass mode.

Select the External Oscillator

To select the external oscillator, the following sequence must be performed:

1. Select the VCO bypass mode (`VCOBYP = 1`).
2. Disconnect the oscillator from the PLL (`OSCDISC = 1`).
3. External OSC is powered up by resetting bit `XPD`.
4. The source of external oscillator is selected by setting bit `OSCSS`.
5. Wait for 50 μ s until the external oscillator is stable.
6. Restart the Oscillator Run Detection by setting bit `OSC_CON.ORDRES`.

If bit `OSC_CON.OSCR` is set, then:

1. Select the VCO bypass mode (`VCOBYP = 1`).
2. Reconnect oscillator to the PLL (`OSCDISC = 0`).
3. Reprogram the `NDIV` factor to the required value.
4. The `RESLD` bit must be set and the `LOCK` flag checked. Only if the `LOCK` flag is set again, can the VCO bypass mode be deselected and normal operation resumed.

In order to minimize power consumption while the on-chip oscillator is used, `XTAL` is powered down by setting bit `XPD`, but when the external oscillator is used, the on-chip oscillator cannot be powered down by setting bit `OSCPD`.

7.3.2 Clock Source Control

The clock system provides four ways to generate CPU clock:

Direct Drive (PLL Bypass Operation)

In PLL bypass operation, the system clock has exactly the same frequency as the external clock source. The PLL bypass is set inactive in the XC866.

$$f_{\text{SYS}} = f_{\text{OSC}}$$

PLL Base Mode

The system clock is derived from the VCO base frequency clock divided by the K factor. Both VCO bypass and PLL bypass must be inactive for this PLL mode.

$$f_{\text{SYS}} = f_{\text{VCObase}} \times \frac{1}{K}$$

Prescaler Mode (VCO Bypass Operation)

In VCO bypass operation, the system clock is derived from the oscillator clock, divided by the P and K factors.

$$f_{\text{SYS}} = f_{\text{OSC}} \times \frac{1}{P \times K}$$

PLL Mode

The system clock is derived from the oscillator clock, divided by the P factor, multiplied by the N factor, and divided by the K factor. Both VCO bypass and PLL bypass must be inactive for this PLL mode.

$$f_{\text{SYS}} = f_{\text{OSC}} \times \frac{N}{P \times K}$$

In normal running mode, the system works in the PLL mode.

For different source oscillator, the selection of typical output frequency $f_{\text{sys}} = 80$ MHz is shown in [Table 7-4](#).

Table 7-4 System frequency ($f_{\text{sys}} = 80$ MHz)

Oscillator	fosc	N	P	K	fsys
On-chip	10 MHz	16	1	2	80 MHz
External	10 MHz	16	1	2	80 MHz
	8 MHz	20	1	2	80 MHz
	5 MHz	32	1	2	80 MHz

For the XC866, the values of P and K are fixed to “1” and “2”, respectively. In order to obtain the required f_{sys} , the value of N can be selected by bit NDIV for different oscillator inputs. See [Table 7-4](#). The output frequency needs to be within the range 75 MHz to 80 MHz.

Table 7-5 shows the VCO range in the XC866.

Table 7-5 VCO Ranges

f_{VCOmin}	f_{VCOmax}	$f_{VCOFREEmin}$	$f_{VCOFREEmax}$	Unit
150	200	40	130	MHz

7.3.3 Clock Management

The Clock Management sub-module generates all clock signals required within the microcontroller from the basic clock. It consists of:

- Basic clock slow down circuitry
- Centralized enable/disable circuit for clock control

Figure 7-5 shows the clock generation from the system frequency f_{sys} . In normal running mode, the typical frequencies of different modules are as follows:

- CPU clock: CCLK, SCLK = 26.7 MHz
- CCU6 clock: FCLK = 26.7 MHz
- Other peripherals: PCLK = 26.7 MHz
- Flash Interface clock: CCLK3 = 80 MHz and CCLK = 26.7 MHz

Furthermore, the oscillator clock outputs to pin CLKOUT(P0.0). In idle mode, only the CPU clock CCLK is disabled. In power-down mode, CCLK, SCLK, FCLK, CCLK3 and PCLK are all disabled. If slow-down mode is enabled, the clock to the core and peripherals will be divided by a programmable factor that is selected by the bit field CMCON.CLKREL.

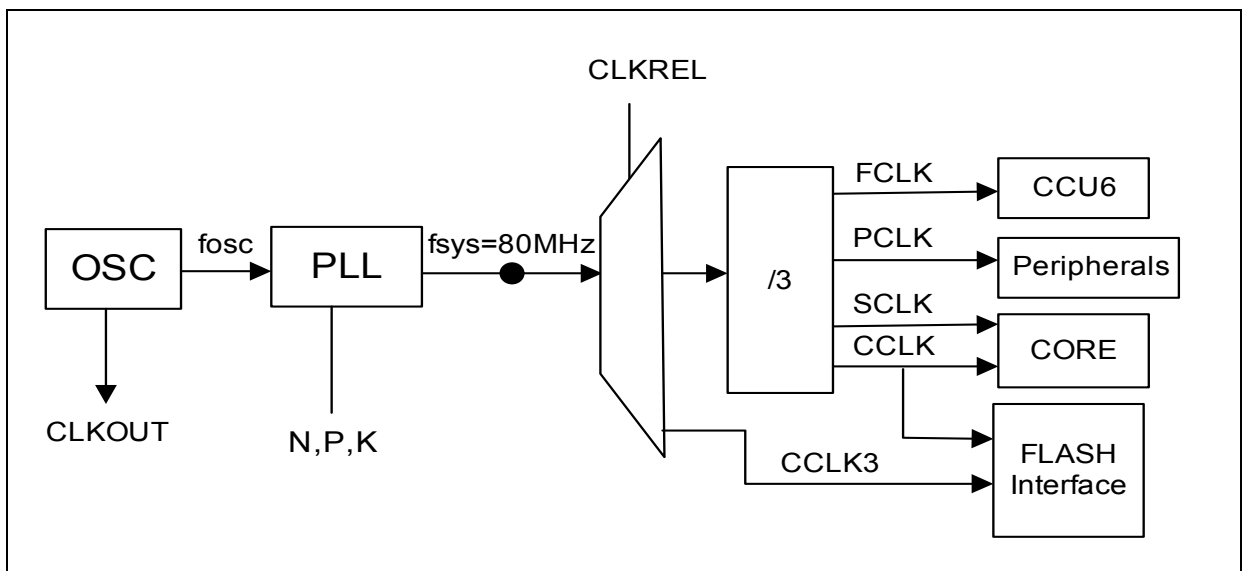

Figure 7-5 Clock Generation from f_{sys}

Power Supply, Reset and Clock Management
7.3.4 Register Description
OSC_CON
OSC Control Register
Reset Value: 0000 1000_B

7	6	5	4	3	2	1	0
0			OSCPD	XPD	OSCSS	ORDRES	OSCR
r			rw	rw	rw	rwh	rh

Field	Bits	Type	Description
OSCR	0	rh	Oscillator Run Status Bit This bit shows the state of the oscillator run detection. 0 The oscillator is not running. 1 The oscillator is running.
ORDRES	1	rwh	Oscillator Run Detection Reset 0 No operation 1 The oscillator run detection logic is reset and restarted. This bit will automatically be reset to 0.
OSCSS	2	rw	Oscillator Source Select 0 On-chip oscillator is selected. 1 External oscillator is selected.
XPD	3	rw	XTAL Power-down Control 0 XTAL is not powered down. 1 XTAL is powered down.
OSCPD	4	rw	On-chip OSC Power-down Control 0 The on-chip oscillator is not powered down. 1 The on-chip oscillator is powered down.
0	[7:5]	r	Reserved Returns 0 if read; should be written with 0.

Note: The reset value of register OSC_CON is 0000 1000_B. One clock cycle after reset, bit OSCR will be set to 1 if the oscillator is running, then the value 0000 1001_B will be observed.

Power Supply, Reset and Clock Management

PLL_CON

PLL Control Register

Reset Value: 0010 0000_B

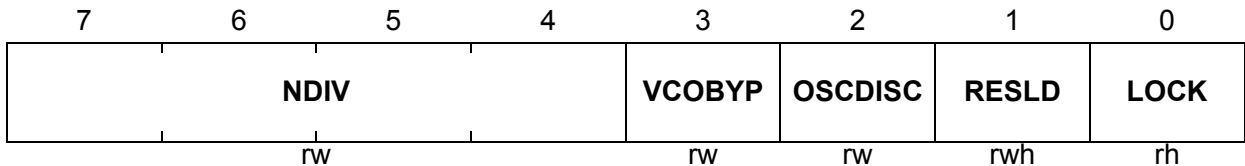

Field	Bits	Type	Description
LOCK	0	rh	PLL Lock Status Flag 0 PLL is not locked. 1 PLL is locked.
RESLD	1	rwh	Restart Lock Detection Setting this bit will reset the PLL lock status flag and restart the lock detection. This bit will automatically be reset to 0 and thus always be read back as 0. 0 No effect 1 Reset lock flag and restart lock detection
OSCDISC	2	rw	Oscillator Disconnect 0 Oscillator is connected to the PLL. 1 Oscillator is disconnected from the PLL.
VCOBYP	3	rw	PLL VCO Bypass Mode Select 0 Normal operation (default) 1 VCO bypass mode (PLL output clock is derived from input clock divided by P- and K-dividers).

Power Supply, Reset and Clock Management

Field	Bits	Type	Description
NDIV	[7:4]	rw	PLL N-Divider 0000 _B N = 14 0001 _B N = 15 0010 _B N = 16 0011 _B N = 17 0100 _B N = 18 0101 _B N = 19 0110 _B N = 20 0111 _B N = 21 1000 _B N = 24 1001 _B N = 28 1010 _B N = 30 1011 _B N = 32 1100 _B N = 40 1101 _B N = 42 1110 _B N = 45 1111 _B N = 50 The NDIV bit is a protected bit. When the Protection Scheme (see Chapter 3.3.4.1) is activated, this bit cannot be written directly.

Note: The reset value of register PLL_CON is 0010 0000_B. One clock cycle after reset, bit LOCK will be set to 1 if the PLL is locked, then the value 0010 0001_B will be observed.

Power Supply, Reset and Clock Management

CMCON

Clock Control Register

Reset Value: 00_H

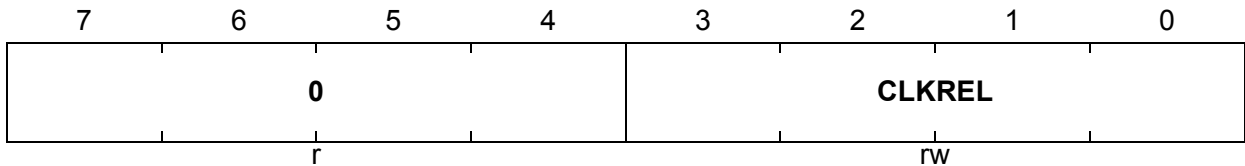

Field	Bits	Type	Description
CLKREL	[3:0]	rw	Clock Divider 0000 _B fsys/1 0001 _B fsys/2 0010 _B fsys/4 0011 _B fsys/8 0100 _B fsys/16 0101 _B fsys/32 0110 _B fsys/64 0111 _B fsys/128 1000 _B fsys/256 1001 _B fsys/512 1010 _B fsys/1024 1011 _B fsys/2048 1100 _B Reserved 1101 _B Reserved 1110 _B Reserved 1111 _B Reserved
0	[7:4]	r	Reserved Returns 0 if read; should be written with 0.

Note: Registers OSC_CON, PLL_CON and CMCON are not reset during the watchdog timer reset.

8 Power Saving Modes

The power saving modes in the XC866 provide flexible power consumption through a combination of techniques, including:

- Stopping the CPU clock
- Stopping the clocks of individual system components
- Reducing clock speed of some peripheral components
- Power-down of the entire system with fast restart capability

After a reset, the active mode (normal operating mode) is selected by default (see [Figure 8-1](#)) and the system runs in the main system clock frequency. From active mode, different power saving modes can be selected by software. They are:

- Idle mode
- Slow-down mode
- Power-down mode

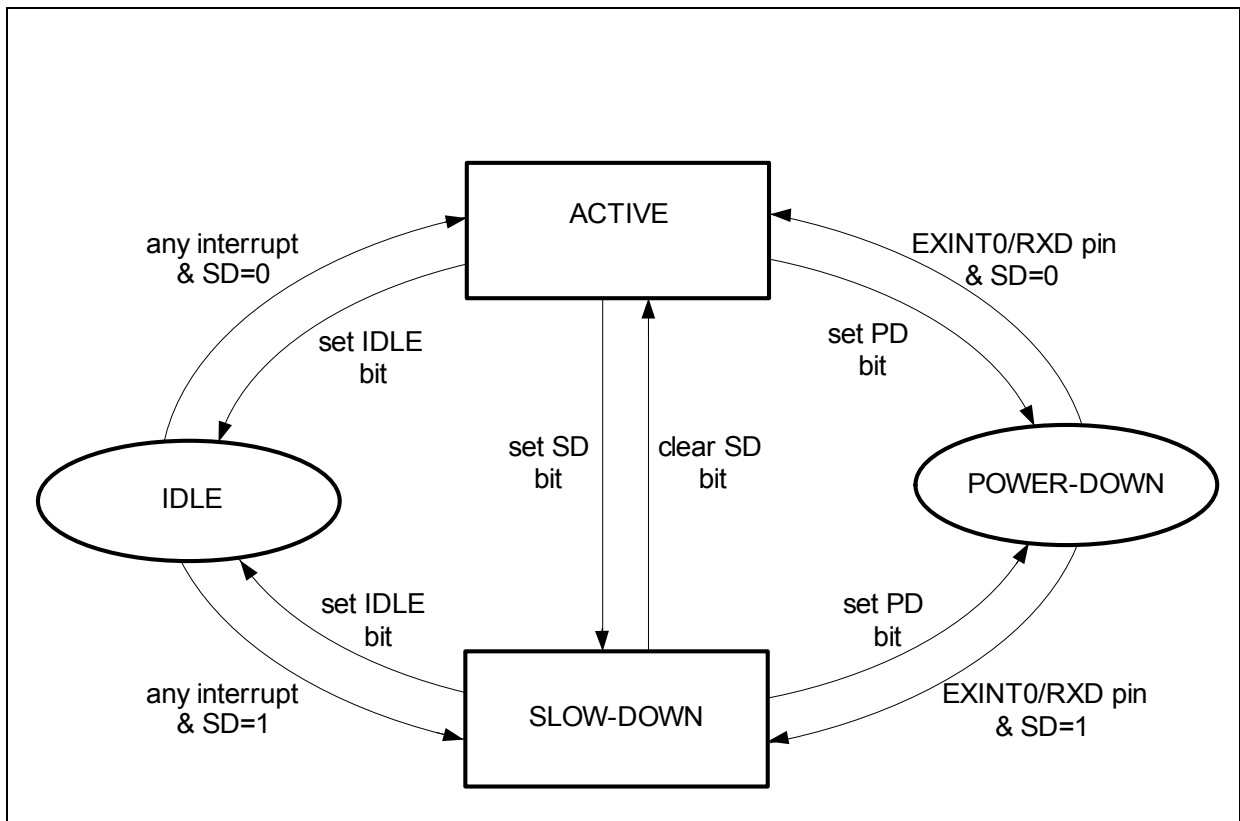

Figure 8-1 Transition between Power Saving Modes

8.1 Functional Description

This section describes the various power saving modes, their operations, and how they are entered and exited.

8.1.1 Idle Mode

The idle mode is used to reduce power consumption by stopping the core's clock.

In idle mode, the oscillator continues to run, but the core is stopped with its clock disabled. Peripherals whose input clocks are not disabled are still functional. The user should disable the Watchdog Timer (WDT) before the system enters the idle mode; otherwise, it will generate an internal reset when an overflow occurs and thus will disrupt the idle mode. The CPU status is preserved in its entirety: the stack pointer, program counter, program status word, accumulator, and all other registers maintain their data during idle mode. The port pins hold the logical state they had at the time the idle mode was activated.

Software requests idle mode by setting the bit PCON.IDLE to 1.

The system will return to active mode on occurrence of any of the following conditions:

- The idle mode can be terminated by activating any enabled interrupt. The CPU operation is resumed and the interrupt will be serviced. Upon RETI instruction, the core will return to execute the next instruction after the instruction which sets the IDLE bit to 1.
- An external hard reset signal ($\overline{\text{RESET}}$) is asserted.

8.1.2 Slow-Down Mode

The slow-down mode is used to reduce power consumption by decreasing the internal clock in the device.

The slow-down mode is activated by setting the bit SD in SFR PMCON0. The bit field CMCON.CLKREL is used to select different slow-down frequency. The CPU and peripherals are clocked at this lower frequency. The slow-down mode is terminated by clearing bit SD.

The slow-down mode can be combined with the idle mode by performing the following sequence:

1. The slow-down mode is activated by setting the bit PMCON0.SD.
2. The idle mode is activated by setting the bit PCON.IDLE.

There are two ways to terminate the combined idle and slow-down modes:

- The idle mode can be terminated by activation of any enabled interrupt. CPU operation is resumed, and the interrupt will be serviced. The next instruction to be executed after the RETI instruction will be the one following the instruction that had set the bit IDLE. Nevertheless, the slow-down mode stays enabled and if required

Power Saving Modes

termination must be done by clearing the bit SD in the corresponding interrupt service routine or at any point in the program where the user no longer requires the slow-down mode.

- The other way of terminating the combined idle and slow-down mode is through a hardware reset.

8.1.3 Power-down Mode

In power-down mode, the oscillator and the PLL are turned off. The FLASH is put into the power-down mode. The main voltage regulator is switched off, but the low power voltage regulator continues to operate. Therefore, all functions of the microcontroller are stopped and only the contents of the FLASH, on-chip RAM, XRAM and the SFRs are maintained. The port pins hold the logical state they had when the power-down mode was activated. For the digital ports, the user must take care from external side that the ports are not floating in power-down mode. This can be done with external pull-up/pull-down or putting the port to output.

In power-down mode, the clock is turned off. Hence, it cannot be awakened by an interrupt or by the WDT. It will be awakened only when it receives an external wake-up signal or reset signal.

Entering Power-down Mode

Software requests power-down mode by setting the bit PMCON0.PD to 1.

If the external wake-up from power-down is used, software must prepare the external environment of the XC866 to trigger one of these signals under the appropriate conditions before entering power-down mode. A wake-up circuit is used to detect a wake-up signal and activate the power-up. During power-down, this circuit remains active. It does not depend on any clocks. Exit from power-down mode can be achieved by applying a falling edge trigger into the:

- EXINT0 pin
- RXD pin
- RXD pin or EXINT0 pin

The wake-up source can be selected by the WS bit of the PMCON0 register. The wake-up with reset or without reset is selected by bit PMCON0.WKSET. The wake-up source and wake-up type must be selected before the system enters the power-down mode.

Exiting Power-down Mode

If power-down mode is exited via a hardware reset, the device is put into the hardware reset state.

When the wake-up source and wake-up type have been selected prior to entering power-down mode, the power-down mode can be exited via EXINT0 pin/RXD pin.

Power Saving Modes

Bit MODPSEL.URRIS is used to select one of the two RXD inputs and bit MODPSEL.EXINT0IS is used to select one of the two EXINT0 inputs.

If bit WKSEL was set to 1 before entering power-down mode, the system will execute a reset sequence similar to the power-on reset sequence. Therefore, all port pins are put into their reset state and will remain in this state until they are affected by program execution.

If bit WKSEL was cleared to 0 before entering power-down mode, a fast wake-up sequence is used. The port pins continue to hold their state which was valid during power-down mode until they are affected by program execution.

The wake-up from power-down without reset uses the following procedures:

1. In power-down mode, EXINT0 pin/RXD pin must be held at high level.
2. Power-down mode is exited when EXINT0 pin/RXD pin goes low for at least 100 ns.
3. The main voltage regulator is switched on and takes approximately 150 μ s to become stable.
4. The on-chip oscillator and the PLL are started. Typically, the on-chip oscillator takes approximately 500 ns to stabilize. The PLL will be locked within 200 μ s after the on-chip oscillator clock is detected for stable nominal frequency.
5. Subsequently, the FLASH will enter ready-to-read mode. This does not require the typical 160 μ s as is the case for the normal reset. The timing for this part can be ignored.
6. The CPU operation is resumed. If wake-up source is EXINT0 pin, the interrupt will be serviced if EXINT0 is enabled before entering power-down mode. Upon RETI instruction, the core will return to execute the next instruction after the instruction which sets the PD bit. If wake-up source is RXD pin, the core will return to execute the next instruction after the instruction which sets the PD bit.

8.1.4 Peripheral Clock Management

The degree of reduction in power consumption that can be achieved by this feature depends on the number of peripherals running. Peripherals that are not required for a particular functionality can be disabled by gating off the clock inputs. For example, in idle mode, if all timers are stopped, and ADC, CCU6 and the serial interfaces are not running, maximum power reduction can be achieved. However, the user must take care in determining which peripherals should continue running and which must be stopped during active and idle modes.

The ADC, SSC, CCU6 and Timer 2 can be disabled (clock is gated off) by setting the corresponding bit in the PMCON1 register. Furthermore, the analog part of the ADC module may be disabled by resetting the GLOBCTR.ANON bit. This feature causes the generation of f_{ADCI} to be stopped and allows a reduction in power consumption when no conversion is needed.

Power Saving Modes

In order to save power consumption when the on-chip oscillator is used, XTAL should be powered down by setting bit OSC_CON.XPD. However, when the external oscillator is used, the on-chip oscillator cannot be powered down by setting bit OSC_CON.OSCPD.

8.2 Register Description

PMCON0

Power Mode Control Register 0

Reset Value: See [Table 8-1](#)

7	6	5	4	3	2	1	0
0	WDTRST	WKRS	WKSEL	SD	PD	WS	
r	rwh	rwh	rw	rw	rwh	rw	



The functions of the shaded bits are not described here

Field	Bits	Type	Description
WS	[1:0]	rw	Wake-up Source Select 00 No wake-up is selected. 01 Wake-up source RXD is selected. 10 Wake-up source EXINT0 is selected. 11 Wake-up source RXD or EXINT0 is selected.
PD	2	rwh	Power-down Enable. Active High. Setting this bit will cause the chip to enter power-down mode. It is reset by wake-up circuit. The PD bit is a protected bit. When the Protection Scheme (see Chapter 3.3.4.1) is activated, this bit cannot be written directly.
SD	3	rw	Slow-down Enable. Active High. Setting this bit will cause the chip to enter slow-down mode. It is reset by the user. The SD bit is a protected bit. When the Protection Scheme is activated, this bit cannot be written directly.
WKSEL	4	rw	Wake-up Reset Select Bit 0 Wake-up without reset 1 Wake-up with reset
WKRS	5	rwh	Wake-up Indication Bit 0 No wake-up occurred. 1 Wake-up has occurred. This bit can only be set by hardware and reset by software.

Power Saving Modes

Field	Bits	Type	Description
0	7	r	Reserved Returns 0 if read; should be written with 0.

Table 8-1 Reset Values of Register PMCON0

Reset Source	Reset Values
Power-on Reset/Hardware Reset/Brownout Reset	0000 0000 _B
Watchdog Timer Reset	0100 0000 _B
Power-down Wake-up Reset	0010 0000 _B

PCON

Power Control Register

Reset Value: 00_H

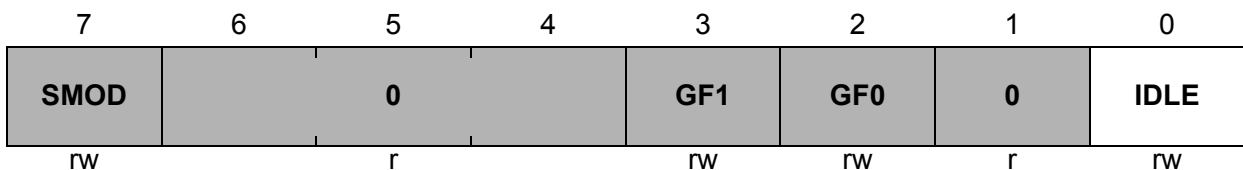

The functions of the shaded bits are not described here

Field	Bits	Type	Description
IDLE	0	rw	Idle Mode Enable 0 Do not enter idle mode 1 Enter idle mode

MODPISEL

Peripheral Input Select Register

Reset Value: 00_H

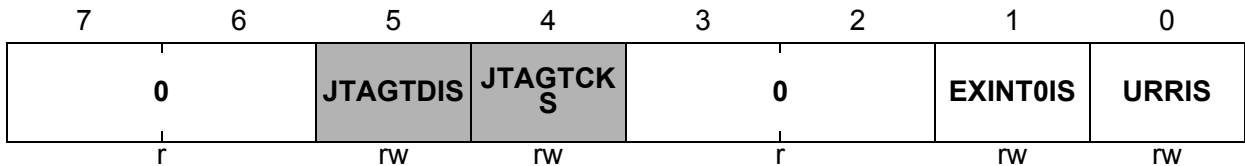

The functions of the shaded bits are not described here

Field	Bits	Type	Description
URRIS	0	rw	UART Receive Input Select 0 UART Receiver Input RXD_0 is selected. 1 UART Receiver Input RXD_1 is selected.
EXINT0IS	1	rw	External Interrupt 0 Input Select 0 External Interrupt Input EXINT0_0 is selected. 1 External Interrupt Input EXINT0_1 is selected.
0	[3:2], [7:6]	r	Reserved Returns 0 if read; should be written with 0.

PMCON1

Power Mode Control Register 1

Reset Value: 00_H

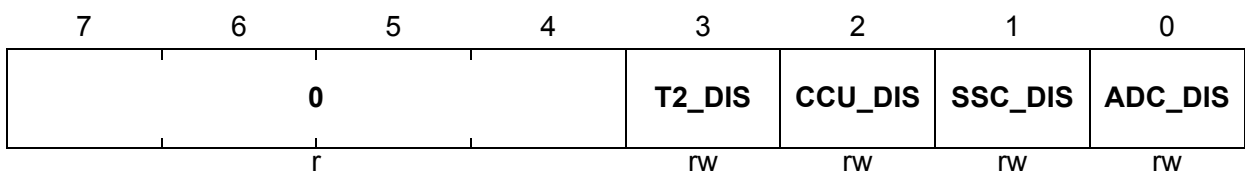

Field	Bits	Type	Description
ADC_DIS	0	rw	ADC Disable Request. Active high. 0 ADC is in normal operation (default). 1 ADC is disabled.
SSC_DIS	1	rw	SSC Disable Request. Active high. 0 SSC is in normal operation (default). 1 SSC is disabled.

Power Saving Modes

Field	Bits	Type	Description
CCU_DIS	2	rw	CCU6 Disable Request. Active High. 0 CCU6 is in normal operation (default). 1 CCU6 is disabled.
T2_DIS	3	rw	Timer 2 Disable Request. Active High. 0 Timer 2 is in normal operation (default). 1 Timer 2 is disabled.
0	[7:4]	r	Reserved Returns 0 if read; should be written with 0.

ADC_GLOBCTR

Global Control Register

Reset Value: 00_H

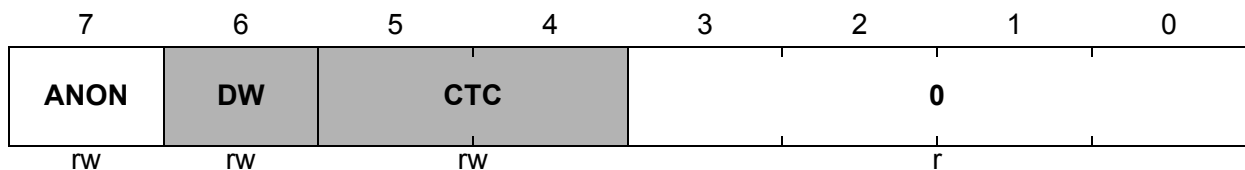

The functions of the shaded bits are not described here

Field	Bits	Type	Description
ANON	7	rw	Analog Part Switched On This bit enables the analog part of the ADC module and defines its operation mode. 0 The analog part is switched off and conversions are not possible. To achieve minimal power consumption, the internal analog circuitry is in its power-down state and the generation of f_{ADC1} is stopped. 1 The analog part of the ADC module is switched on and conversions are possible. The automatic power-down capability of the analog part is disabled.
0	[3:0]	r	Reserved Returns 0 if read; should be written with 0.

Power Saving Modes

OSC_CON

OSC Control Register

Reset Value: 0000 1000_B

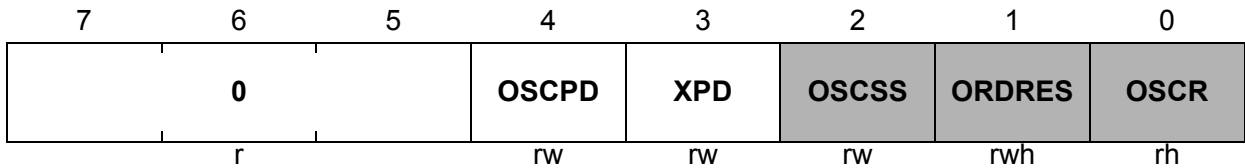

The functions of the shaded bits are not described here

Field	Bits	Type	Description
XPD	3	rw	XTAL Power-down Control 0 XTAL is not powered down. 1 XTAL is powered down.
OSCPD	4	rw	On-chip OSC Power-down Control 0 The on-chip oscillator is not powered down. 1 The on-chip oscillator is powered down.
0	[7:5]	r	Reserved Returns 0 if read; should be written with 0.

9 Watchdog Timer

The Watchdog Timer (WDT) provides a highly reliable and secure way to detect and recover from software or hardware failures. The WDT is reset at a regular interval that is predefined by the user. The CPU must service the WDT within this time interval to prevent the WDT from causing an XC866 system reset. Hence, routine service of the WDT confirms that the system is functioning properly. This ensures that an accidental malfunction of the XC866 will be aborted in a user-specified time period.

Features:

- 16-bit Watchdog Timer
- Programmable reload value for upper 8 bits of timer
- Programmable window boundary
- Selectable input frequency of $f_{PCLK}/2$ or $f_{PCLK}/128$

9.1 Functional Description

The Watchdog Timer (WDT) is a 16-bit timer, which is incremented by a count rate of $f_{PCLK}/2$ or $f_{PCLK}/128$. This 16-bit timer is realized as two concatenated 8-bit timers. The upper 8 bits of the WDT can be preset to a user-programmable value via a watchdog service access in order to modify the watchdog expire time period. The lower 8 bits are reset on each service access. **Figure 9-1** shows the block diagram of the WDT unit.

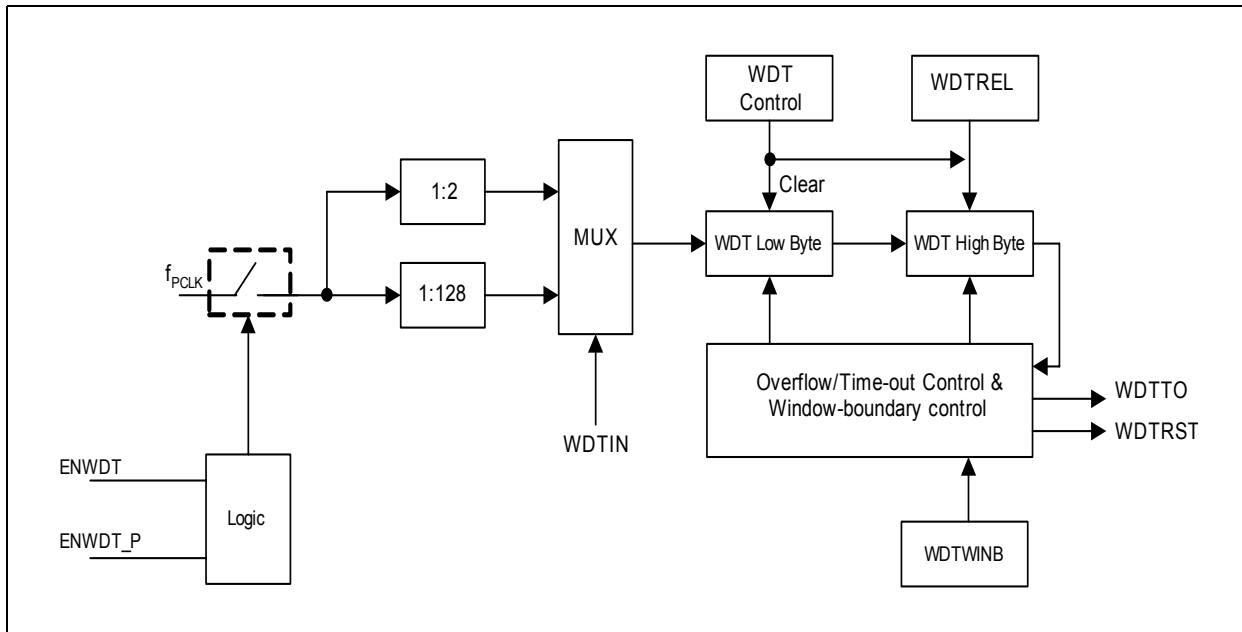

Figure 9-1 WDT Block Diagram

If the WDT is enabled by setting bit WDTEN to 1, the timer is set to a user-defined start value and begins counting up. It must be serviced before the counter overflows. Servicing is performed through the refresh operation (setting WDTRS to 1). This reloads the timer with the start value, and normal operation continues.

If the WDT is not serviced before the timer overflows, a system malfunction is assumed and normal mode is terminated. A WDT NMI request (WDTTO) is then asserted and prewarning is entered. The prewarning lasts for 30_H count. During the prewarning period, refreshing of the WDT is ignored and the WDT cannot be disabled. A reset (WDRST) of the XC866 is imminent and can no longer be stopped. The occurrence of a WDT reset is indicated by the bit WDRST, which is set to 1 once hardware detects the assertion of the signal WDRST. If refresh happens at the same time an overflow occurs, WDT will not go into prewarning period.

The WDT must be serviced periodically so that its count value will not overflow. Servicing the WDT clears the low byte and reloads the high byte with the preset value in bit field WDTREL. Servicing the WDT also clears the bit WDTRS.

The WDT has a “programmable window boundary”, which disallows any refresh during the WDT’s count-up. A refresh during this window-boundary constitutes an invalid

Watchdog Timer

access to the WDT and causes the WDT to activate WDTRST, although no NMI request is generated in this instance. The window boundary is from 0000_H to the value obtained from the concatenation of WDTWINB and 00_H. This feature can be enabled by WINBEN. After being serviced, the WDT continues counting up from the value (<WDTREL> * 2⁸). The time period for an overflow of the WDT is programmable in two ways:

- the input frequency to the WDT can be selected via bit WDTIN in register WDTCON to be either f_{PCLK}/2 or f_{PCLK}/128.
- the reload value WDTREL for the high byte of WDT can be programmed in register WDTREL.

The period P_{WDT} between servicing the WDT and the next overflow can be determined by the following formula:

$$P_{WDT} = \frac{2^{(1 + WDTIN \times 6)} \times (2^{16} - WDTREL \times 2^8)}{f_{PCLK}}$$

If the Window-Boundary Refresh feature of the WDT is enabled, the period P_{WDT} between servicing the WDT and the next overflow is shortened if WDTWINB is greater than WDTREL. See also [Figure 9-2](#). This period can be calculated by the same formula by replacing WDTREL with WDTWINB. In order for this feature to be useful, WDTWINB cannot be smaller than WDTREL.

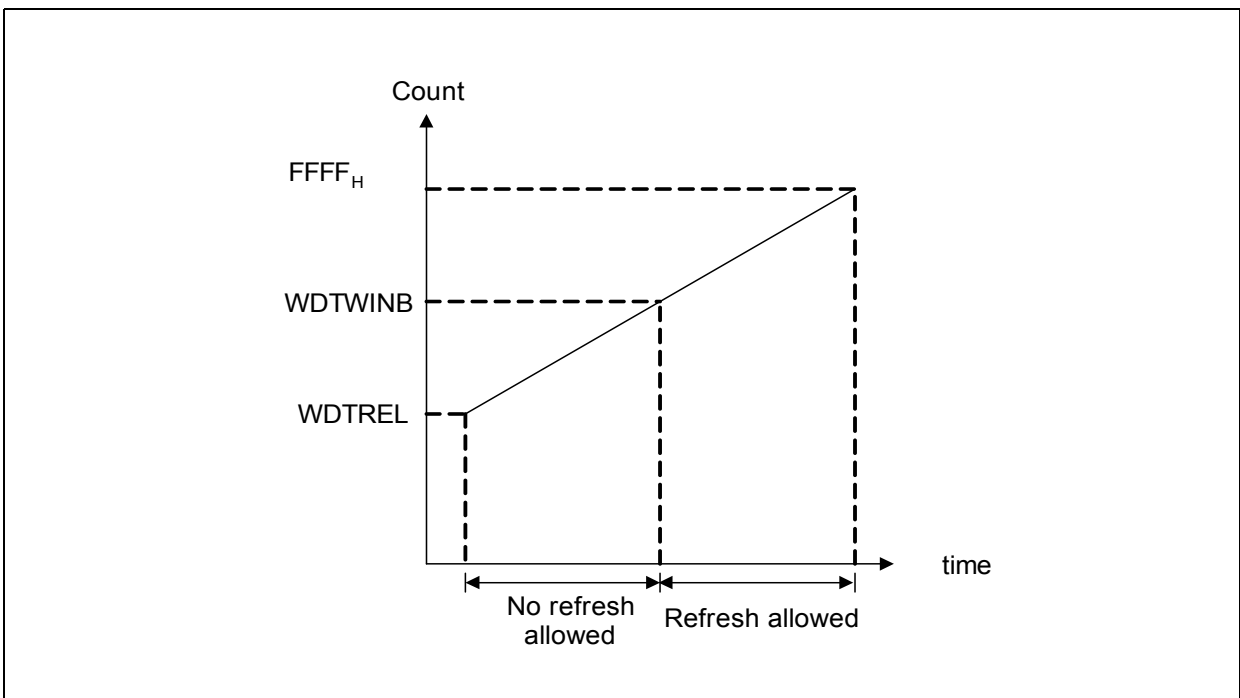

Figure 9-2 WDT Timing Diagram

Watchdog Timer

Table 9-1 lists the possible ranges for the watchdog time which can be achieved using a certain module clock. Some numbers are rounded to 3 significant digits.

Table 9-1 Watchdog Time Ranges

Reload value in WDTREL	Prescaler for f_{PCLK}					
	2 (WDTIN = 0)			128 (WDTIN = 1)		
	20 MHz	16 MHz	12 MHz	20 MHz	16 MHz	12 MHz
FF _H	25.6 μ s	32.0 μ s	42.67 μ s	1.64 ms	2.05 ms	2.73 ms
7F _H	3.3 ms	4.13 ms	5.5 ms	211 ms	264 ms	352 ms
00 _H	6.55 ms	8.19 ms	10.92 ms	419 ms	524 ms	699 ms

Note: For safety reasons, the user is advised to rewrite WDTCON each time before the WDT is serviced.

9.2 Register Map

The WDT SFRs are located in the mapped SFR area. [Table 9-2](#) lists the addresses of these SFRs.

Table 9-2 SFR Address list

Address	Name
BB _H	WDTCON
BC _H	WDTREL
BD _H	WDTWINB
BE _H	WDTL
BF _H	WDTH

9.3 Register Description

The current count value of the WDT is contained in the Watchdog Timer Register WDT, which is a non-bitaddressable read-only register. The operation of the WDT is controlled by its bitaddressable WDT Control Register WDTCON. This register also selects the input clock prescaling factor. The register WDTREL specifies the reload value for the high byte of the timer.

WDTREL

Watchdog Timer Reload Register

Reset Value: 00_H

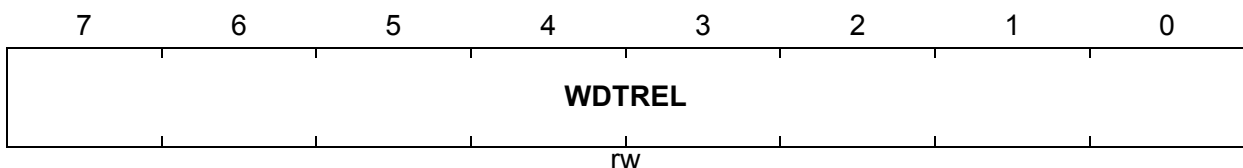

Field	Bits	Type	Description
WDTREL	[7:0]	rw	Watchdog Timer Reload Value (for the high byte of WDT) A new reload value can be written to WDTREL and this value is loaded to the upper 8 bits of the WDT upon the enabling of the timer or the next service for refresh.

Watchdog Timer

WDTCON

Watchdog Timer Control Register

Reset Value: 00_H

7	6	5	4	3	2	1	0
0	WINBEN	WDTPR	0	WDTEN	WDTRS	WDTIN	
r	rw	rh	r	rw	rwh	rw	

Field	Bits	Type	Description
WDTIN	0	rw	Watchdog Timer Input Frequency Selection 0 Input frequency is $f_{WDT}/2$. 1 Input frequency is $f_{WDT}/128$.
WDTRS	1	rwh	WDT Refresh Start Active high. Set to start refresh operation on the WDT. Cleared automatically by hardware.
WDTEN	2	rw	WDT Enable 0 WDT is disabled. 1 WDT is enabled. WDTEN is a protected bit. If the Protection Scheme (see Chapter 3.3.4.1) is activated, then this bit cannot be written directly.
WDTPR	4	rh	Watchdog Prewarning Mode Flag 0 Normal mode (default after reset) 1 The Watchdog is operating in prewarning mode. This bit is set to 1 when a Watchdog error is detected. The WDT has issued an NMI trap and is in prewarning mode. A reset of the chip occurs after the prewarning period has expired.
WINBEN	5	rw	Watchdog Window-Boundary Enable 0 Watchdog Window-Boundary feature is disabled (default). 1 Watchdog Window-Boundary feature is enabled.
0	3, [7:6]	r	Reserved Returns 0 if read; should be written with 0.

Watchdog Timer

WDTL

Watchdog Timer Register Low

Reset Value: 00_H

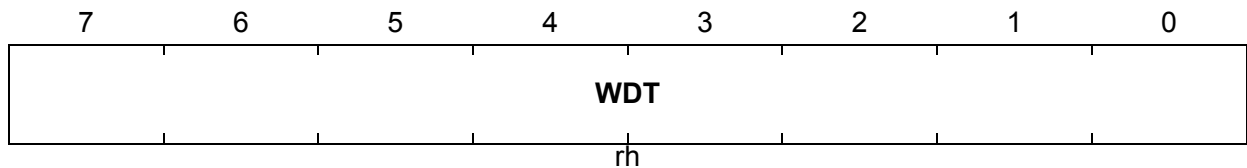

WDTH

Watchdog Timer Register High

Reset Value: 00_H

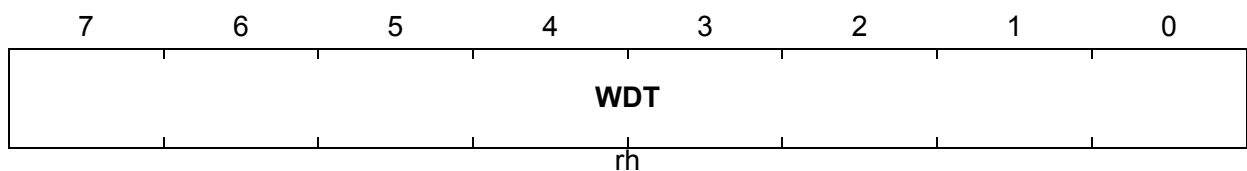

Field	Bits	Type	Description
WDT	[7:0] of WDTL, [7:0] of WDTH	rh	Watchdog Timer Current Value

WDTWINB

Watchdog Window-Boundary Count

Reset Value: 00_H

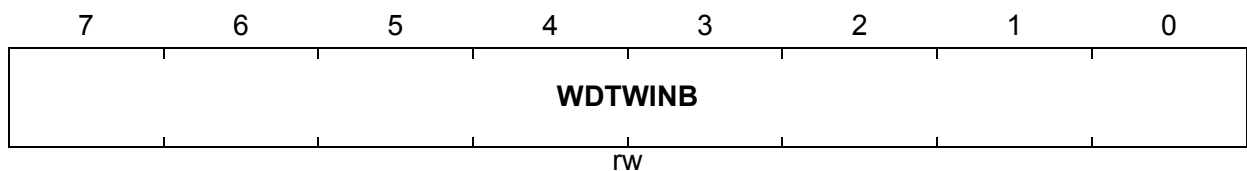

Field	Bits	Type	Description
WDTWINB	[7:0]	rw	Watchdog Window-Boundary Count Value This value is programmable. The WDT cannot do a refresh within the Window Boundary range from 0000 _H to the value obtained from the concatenation of WDTWINB and 00 _H , as it would cause WDTRST to be asserted. WDTWINB is matched to WDTH.

PMCON0

Power Mode Control Register 0

Reset Value: See [Table 8-1](#)

7	6	5	4	3	2	1	0
0	WDTRST	WKRS	WKSEL	SD	PD	WS	
r	rwh	rwh	rw	rw	rwh	rw	



The functions of the shaded bits are not described here

Field	Bits	Type	Description
WDTRST	6	rwh	Watchdog Timer Reset Indication Bit 0 No WDT reset has occurred. 1 WDT reset has occurred.
0	7	r	Reserved Returns 0 if read; should be written with 0.

10 Serial Interfaces

The XC866 contains two serial interfaces, the Universal Asynchronous Receiver/Transmitter (UART) and the High-Speed Synchronous Serial Interface (SSC), for serial communication with external devices. Additionally, the UART can be used to support the Local Interconnect Network (LIN) protocol.

UART Features:

- Full-duplex asynchronous modes
 - 8-bit or 9-bit data frames, LSB first
 - fixed or variable baud rate
- Receive buffered
- Multiprocessor communication
- Interrupt generation on the completion of a data transmission or reception

LIN Features:

- Master and slave mode operation

SSC Features:

- Master and slave mode operation
 - Full-duplex or half-duplex operation
- Transmit and receive buffered
- Flexible data format
 - Programmable number of data bits: 2 to 8 bits
 - Programmable shift direction: LSB or MSB shift first
 - Programmable clock polarity: idle low or high state for the shift clock
 - Programmable clock/data phase: data shift with leading or trailing edge of the shift clock
- Variable baud rate
- Compatible with Serial Peripheral Interface (SPI)
- Interrupt generation
 - On a transmitter empty condition
 - On a receiver full condition
 - On an error condition (receive, phase, baud rate, transmit error)

10.1 UART

The UART provides a full-duplex asynchronous receiver/transmitter, i.e., it can transmit and receive simultaneously. It is also receive-buffered, i.e., it can commence reception of a second byte before a previously received byte has been read from the receive register. However, if the first byte still has not been read by the time reception of the second byte is complete, one of the bytes will be lost.

10.1.1 UART Modes

The UART can be used in three asynchronous modes. In mode 1, it operates as an 8-bit serial port, and in modes 2 and 3, it operates as a 9-bit serial port. The only difference between mode 2 and mode 3 is the baud rate, which is fixed in mode 2 but variable in mode 3. The variable baud rate is derived from the dedicated baud-rate generator.

The different modes are selected by setting bits SM0 and SM1 to their corresponding values, as shown in [Table 10-1](#). The selection where the value of both SM0 and SM1 is zero, is reserved.

Table 10-1 UART Modes

SM0	SM1	Operating Mode	Baud Rate
0	0	Reserved	–
0	1	Mode 1: 8-bit shift UART	Variable
1	0	Mode 2: 9-bit shift UART	$f_{PCLK}/32$ or $f_{PCLK}/64$
1	1	Mode 3: 9-bit shift UART	Variable

10.1.1.1 Mode 1, 8-Bit UART, Variable Baud Rate

In mode 1, the UART behaves as an 8-bit serial port. A start bit (0), 8 data bits, and a stop bit (1) are transmitted on TXD or received on RXD at the baud rate set by the underflow rate on the dedicated baud-rate generator. This baud rate is variable.

The transmission cycle is activated by a write to SBUF. The data is transferred to the transmit register and a 1 is loaded to the 9th bit position. At phase 1 of the machine cycle after the next rollover in the divide-by-16 counter, the start bit is copied to TXD, and data is activated one bit time later. One bit time after the data is activated, the data starts getting shifted right with zeros shifted in from the left. When the MSB gets to the output position, the control block executes one last shift and sets the TI bit.

Reception is started by a high to low transition on RXD (sampled at 16 times the baud rate). The divide-by-16 counter is then reset and 1111 1111_B is written to the receive register. If a valid start bit (0) is then detected (based on two out of three samples), it is shifted into the register followed by 8 data bits. If the transition is not followed by a valid start bit, the controller goes back to looking for a high to low transition on RXD. When the

Serial Interfaces

start bit reaches the leftmost position, the control block executes one last shift, then loads SBUF with the 8 data bits, loads RB8 (SCON.2) with the stop bit, and sets the RI bit, provided RI = 0, and either SM2 = 0 (see [Section 10.1.2](#)) or the received stop bit = 1. If none of these conditions is met, the received byte is lost.

The associated timings for transmit/receive in mode 1 are illustrated in [Figure 10-1](#).

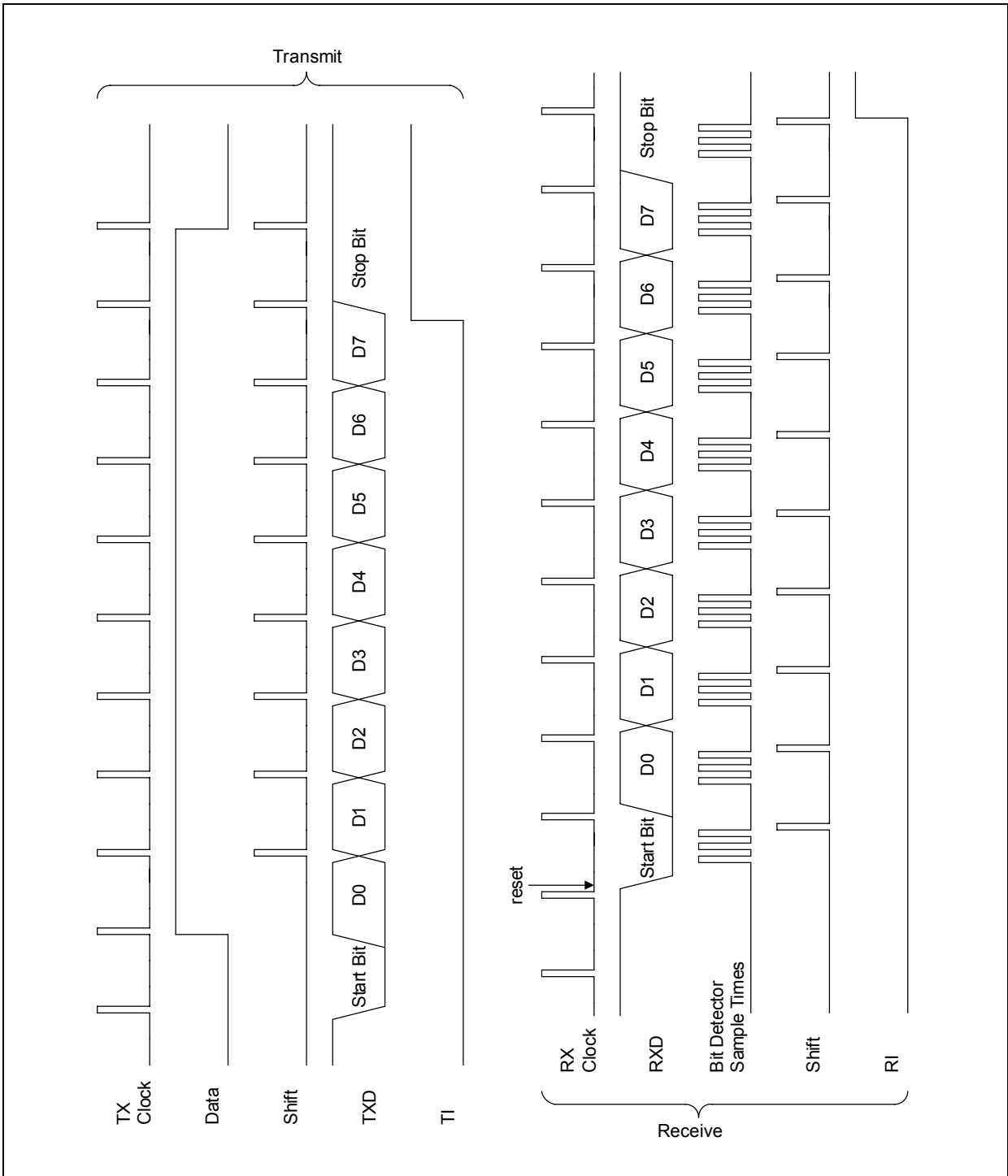

Figure 10-1 Serial Interface, Mode 1, Timing Diagram

10.1.1.2 Mode 2, 9-Bit UART, Fixed Baud Rate

In mode 2, the UART behaves as a 9-bit serial port. A start bit (0), 8 data bits plus a programmable 9th bit and a stop bit (1) are transmitted on TXD or received on RXD. The 9th bit for transmission is taken from TB8 (SCON.3) while for reception, the 9th bit received is placed in RB8 (SCON.2).

The transmission cycle is activated by a write to SBUF. The data is transferred to the transmit register and TB8 is copied into the 9th bit position. At phase 1 of the machine cycle following the next rollover in the divide-by-16 counter, the start bit is copied to TXD and data is activated one bit time later. One bit time after the data is activated, the data starts shifting right. For the first shift, a stop bit (1) is shifted in from the left and for subsequent shifts, zeros are shifted in. When the TB8 bit gets to the output position, the control block executes one last shift and sets the TI bit.

Reception is started by a high to low transition on RXD (sampled at 16 times the baud rate). The divide-by-16 counter is then reset and 1111 1111_B is written to the receive register. If a valid start bit (0) is then detected (based on two out of three samples), it is shifted into the register followed by 8 data bits. If the transition is not followed by a valid start bit, the controller goes back to looking for a high to low transition on RXD. When the start bit reaches the leftmost position, the control block executes one last shift, then loads SBUF with the 8 data bits, loads RB8 (SCON.2) with the 9th data bit, and sets the RI bit, provided RI = 0, and either SM2 = 0 (see [Section 10.1.2](#)) or the 9th bit = 1. If none of these conditions is met, the received byte is lost.

The baud rate for the transfer is either $f_{PCLK}/64$ or $f_{PCLK}/32$, depending on the setting of the top bit (SMOD) of the PCON (Power Control) register, which acts as a Double Baud Rate selector.

10.1.1.3 Mode 3, 9-Bit UART, Variable Baud Rate

Mode 3 is the same as mode 2 in all respects except that the baud rate is variable and is set by the underflow rate on the dedicated baud-rate generator.

In all modes, transmission is initiated by any instruction that uses SBUF as a destination register. Reception is initiated in the modes by the incoming start bit if REN = 1.

The serial interface also provides interrupt requests when transmission or reception of the frames has been completed. The corresponding interrupt request flags are TI or RI, respectively. If the serial interrupt is not used (i.e., serial interrupt not enabled), TI and RI can also be used for polling the serial interface.

The associated timings for transmit/receive in modes 2 and 3 are illustrated in [Figure 10-2](#).

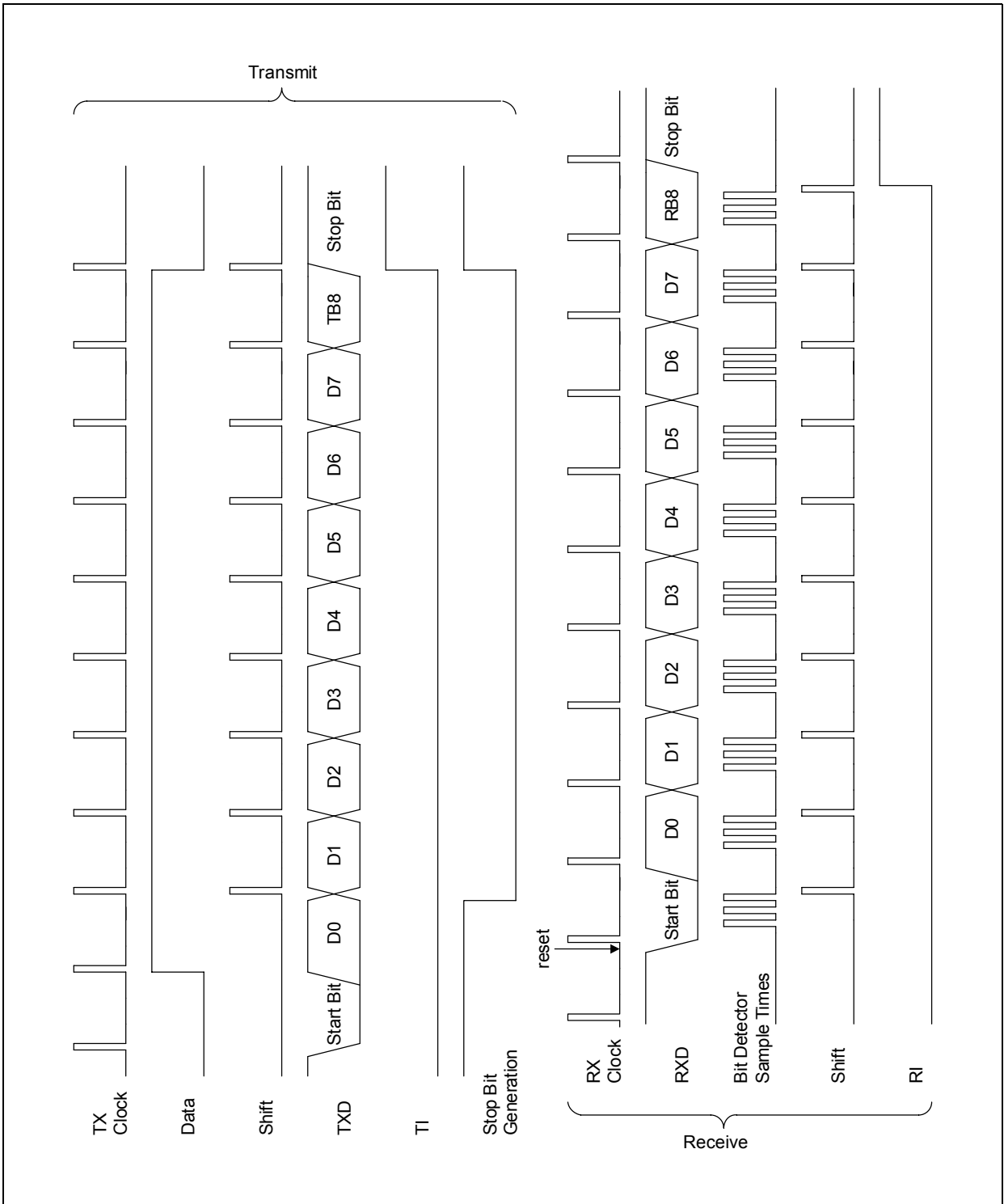

Figure 10-2 Serial Interface, Modes 2 and 3, Timing Diagram

10.1.2 Multiprocessor Communication

Modes 2 and 3 have a special provision for multiprocessor communication using a system of address bytes with bit 9 = 1 and data bytes with bit 9 = 0. In these modes, 9 data bits are received. The 9th data bit goes into RB8. The communication always ends with one stop bit. The port can be programmed such that when the stop bit is received, the serial port interrupt will be activated only if RB8 = 1.

This feature is enabled by setting bit SM2 in SCON. One of the ways to use this feature in multiprocessor systems is described in the following paragraph.

When the master processor wants to transmit a block of data to one of several slaves, it first sends out an address byte that identifies the target slave. An address byte differs from a data byte in that the 9th bit is 1 in an address byte and 0 in a data byte. With SM2 = 1, no slave will be interrupted by a data byte. An address byte, however, will interrupt all slaves, so that each slave can examine the received byte and see if it is being addressed. The addressed slave will clear its SM2 bit and prepare to receive the data bytes that will be coming. The slaves that were not being addressed retain their SM2s as set and ignore the incoming data bytes.

Bit SM2 can be used in mode 1 to check the validity of the stop bit. In a mode 1 reception, if SM2 = 1, the receive interrupt will not be activated unless a valid stop bit is received.

10.1.3 Register Description

The UART uses two Special Function Registers (SFRs), SCON and SBUF. SCON is the control register and SBUF is the data register. On reset, both SCON and SBUF return 00_H. The serial port control and status register is the SFR SCON. This register contains not only the mode selection bits, but also the 9th data bit for transmit and receive (TB8 and RB8) and the serial port interrupt bits (TI and RI).

SBUF is the receive and transmit buffer of the serial interface. Writing to SBUF loads the transmit register and initiates transmission. This register is used for both transmit and receive data. Transmit data is written to this location and receive data is read from this location, but the two paths are independent.

Reading out SBUF accesses a physically separate receive register.

SBUF

Serial Data Buffer

Reset Value: 00_H

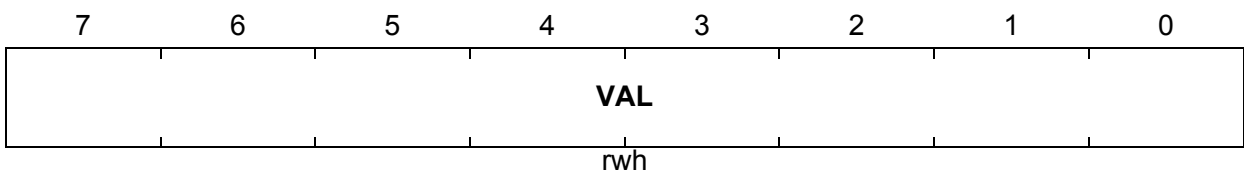

Serial Interfaces

Field	Bits	Type	Description
VAL	[7:0]	rwh	Serial Interface Buffer Register

SCON
Serial Channel Control Register
Reset Value: 00_H

7	6	5	4	3	2	1	0
SM0	SM1	SM2	REN	TB8	RB8	TI	RI
rw	rw	rw	rw	rw	rwh	rwh	rwh

Field	Bits	Type	Description
RI	0	rwh	Receive Interrupt Flag This is set by hardware at the half point of the stop bit in modes 1, 2, and 3. Must be cleared by software.
TI	1	rwh	Transmit Interrupt Flag This is set by hardware at the beginning of the stop bit in modes 1, 2, and 3. Must be cleared by software.
RB8	2	rwh	Serial Port Receiver Bit 9 In modes 2 and 3, this is the 9th data bit received. In mode 1, this is the stop bit received.
TB8	3	rw	Serial Port Transmitter Bit 9 In modes 2 and 3, this is the 9th data bit sent.
REN	4	rw	Enable Receiver of Serial Port 0 Serial reception is disabled. 1 Serial reception is enabled.
SM2	5	rw	Enable Serial Port Multiprocessor Communication in Modes 2 and 3 In mode 2 or 3, if SM2 is set to 1, RI will not be activated if the received 9th data bit (RB8) is 0. In mode 1, if SM2 is set to 1, RI will not be activated if a valid stop bit (RB8) was not received.

Field	Bits	Type	Description															
SM1 SM0	6 7	rw	Serial Port Operating Mode Selection <table border="1" style="margin-top: 10px;"> <thead> <tr> <th>SM0</th> <th>SM1</th> <th>Selected operating mode</th> </tr> </thead> <tbody> <tr> <td>0</td> <td>0</td> <td>Mode 0: Reserved</td> </tr> <tr> <td>0</td> <td>1</td> <td>Mode 1: 8-bit UART, variable baud rate</td> </tr> <tr> <td>1</td> <td>0</td> <td>Mode 2: 9-bit UART, fixed baud rate ($f_{PCLK}/32$ or $f_{PCLK}/64$)</td> </tr> <tr> <td>1</td> <td>1</td> <td>Mode 3: 9-bit UART, variable baud rate</td> </tr> </tbody> </table>	SM0	SM1	Selected operating mode	0	0	Mode 0: Reserved	0	1	Mode 1: 8-bit UART, variable baud rate	1	0	Mode 2: 9-bit UART, fixed baud rate ($f_{PCLK}/32$ or $f_{PCLK}/64$)	1	1	Mode 3: 9-bit UART, variable baud rate
SM0	SM1	Selected operating mode																
0	0	Mode 0: Reserved																
0	1	Mode 1: 8-bit UART, variable baud rate																
1	0	Mode 2: 9-bit UART, fixed baud rate ($f_{PCLK}/32$ or $f_{PCLK}/64$)																
1	1	Mode 3: 9-bit UART, variable baud rate																

10.1.4 Baud Rate Generation

There are several ways to generate the baud rate clock for the serial port, depending on the mode in which it is operating.

“Baud rate clock” and “baud rate” must be distinguished from each other. The serial interface requires a clock rate that is 16 times the baud rate for internal synchronization. Therefore, the baud-rate generators must provide a “baud rate clock” to the serial interface where it is divided by 16 to obtain the actual “baud rate”. The abbreviation f_{PCLK} refers to the input clock frequency.

In mode 2, the baud rate is either $f_{PCLK}/64$ or $f_{PCLK}/32$ depending on the setting of PCON.SM0D, which acts as a Double Baud Rate selector.

However, when the serial port is being used in either mode 1 or mode 3, it has a variable baud rate principally set by the underflow rate of the dedicated baud-rate generator.

Serial Interfaces

The fixed baud rate of the serial port in mode 2 is controlled by bit SMOD in SFR PCON, as shown below. The variable baud rate supplied by the dedicated baud-rate generator, for modes 1 and 3, is unaffected by this bit.

PCON

Power Control Register

Reset Value: 00_H

7	6	5	4	3	2	1	0
SMOD	0			GF1	GF0	0	IDLE
rw	r			rw	rw	r	rw



The functions of the shaded bits are not described here

Field	Bits	Type	Description
SMOD	7	rw	<p>Double Baud Rate Enable</p> <p>0 Do not double the baud rate of serial interface in mode 2.</p> <p>1 Double baud rate of serial interface in mode 2.</p>

Note: Depending on the programmed operating mode, different paths are selected for the baud rate clock.

10.1.4.1 Baud-rate Generator

The XC866 provides a dedicated baud-rate generator to generate the baud rate for the UART module. It has programmable 8-bit reload value and 3-bit prescaler.

The baud-rate generator is clocked with a clock (f_{DIV}) derived via a prescaler from the input clock f_{CLK} . The baud rate timer counts downwards and can be started or stopped through the baud rate control run bit BCON.R. Each underflow of the timer provides one clock pulse to the serial channel. The timer is reloaded with the value stored in its 8-bit reload register each time it underflows. The prescaler is selected by the bit field BCON.BRPRE.

Register BG is the dual-function Baud-rate Generator/Reload register. Reading BG returns the contents of the timer, while writing to BG always updates the reload register.

An auto-reload of the timer with the contents of the reload register is performed each time BG is written to. However, if BCON.R is cleared at the time a write operation to BG is performed, the timer will not be reloaded until the first instruction cycle after BCON.R is set.

The baud rate of the baud-rate generator depends on the following bits and register values:

- Input clock f_{PCLK}
- Value of register BCON.BRPRE
- Value of the 8-bit reload register BG

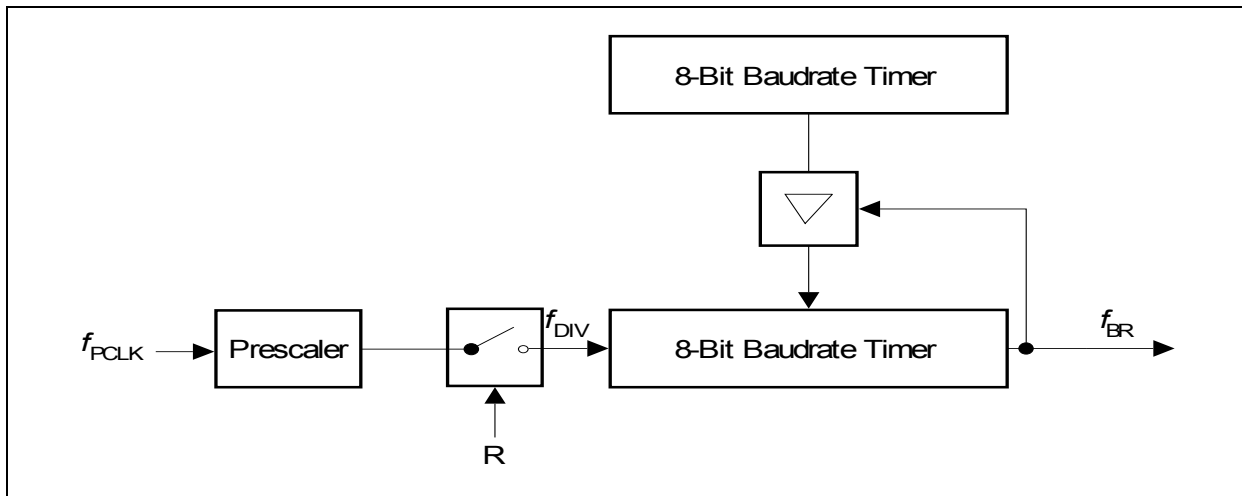

Figure 10-3 Baud-rate Generator Circuitry

The serial interface requires a clock rate which is 16 times the baud rate for internal synchronization. Therefore, the baud-rate generators must provide a “baud rate clock” to the serial interface, which is divided by 16 and results in the actual baud rate. The following formula includes the factor and calculates the final baud rate.

$$\text{baud rate} = \frac{f_{PCLK}}{16 \times \text{PRE} \times (\text{BG} + 1)}$$

The value of PRE (prescaler) is chosen by the bit BCON.BRPRE. BG represents the contents of the reload register BG.BR_VALUE, which is taken as unsigned 8-bit integer. The maximum baud rate that can be achieved for a module clock of 26.7 MHz is 1.67 MBaud. [Table 10-2](#) lists various commonly used baud rates together with the required reload values and the deviation errors compared to the intended baud rate.

Table 10-2 Typical Baud Rates of UART

Baud rate ($f_{PCLK} = 26.7 \text{ MHz}$)	PRE	Reload Value	Deviation Error
19.2 kBaud	1 (BRPRE=000)	87 (57_H)	-0.22 %
9600 Baud	1 (BRPRE=000)	174 (AE_H)	-0.22 %
4800 Baud	2 (BRPRE=001)	174 (AE_H)	-0.22 %
2400 Baud	4 (BRPRE=010)	174 (AE_H)	-0.22 %

Register BCON contains control bits for baud-rate generator and the prescaler bit field.

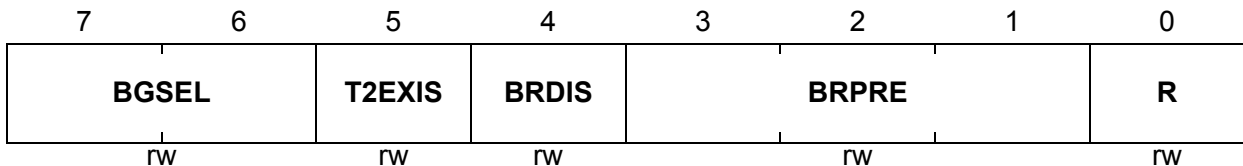
BCON
Baud Rate Control Register
Reset Value: 00_H

Field	Bits	Type	Description
R	0	rw	Baud-rate Generator Run Control Bit 0 Baud-rate generator is disabled. 1 Baud-rate generator is enabled. <i>Note: BR_VALUE should only be written if R = 0.</i>
BRPRE	[3:1]	rw	Prescaler Bit Selects the input clock for f_{DIV} which is derived from the peripheral clock. 000 $f_{DIV} = f_{PCLK}$ 001 $f_{DIV} = f_{PCLK}/2$ 010 $f_{DIV} = f_{PCLK}/4$ 011 $f_{DIV} = f_{PCLK}/8$ 100 $f_{DIV} = f_{PCLK}/16$ 101 $f_{DIV} = f_{PCLK}/32$ Others: reserved
BRDIS	4	rw	Baud Rate Detection Disable 0 Baud rate detection is enabled. 1 Baud rate detection is disabled.
T2EXIS	5	rw	T2EX Function Select 0 T2EX is selected for baud rate detection. 1 T2EX is selected for Timer 2 function.
BGSEL	[7:6]	rw	Baud Rate Select for detection 00 10 kHz to 20 kHz 01 5 kHz to 10 kHz 10 2.5 kHz to 5 kHz 11 1.25 kHz to 2.5 kHz

Register BG contains the 8-bit reload value for the baud rate timer.

BG

Baud Rate Timer/Reload Register

Reset Value: 00_H

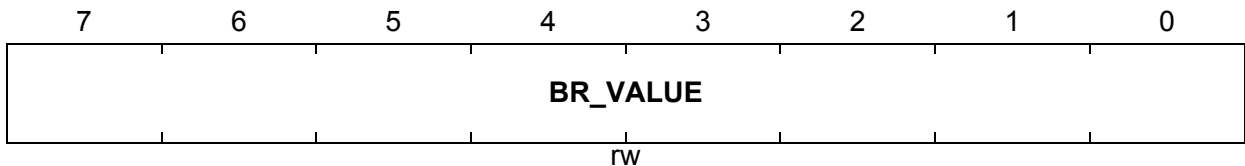

Field	Bits	Type	Description
BR_VALUE	[7:0]	rw	<p>Baud Rate Timer/Reload Value Reading returns the 8-bit content of the baud rate timer; writing loads the baud rate timer/reload value. <i>Note: BG should only be written if R = 0.</i></p>

10.1.5 Interfaces of UART

The UART has two input/output lines; TXD for data transmission and RXD for data reception.

Data that is shifted into the UART module through RXD can be selected from two different sources, RXD_0 and RXD_1. This selection is performed by the SFR bit MODPISEL.URRIS.

MODPISEL

Peripheral Input Select Register

Reset Value: 00_H

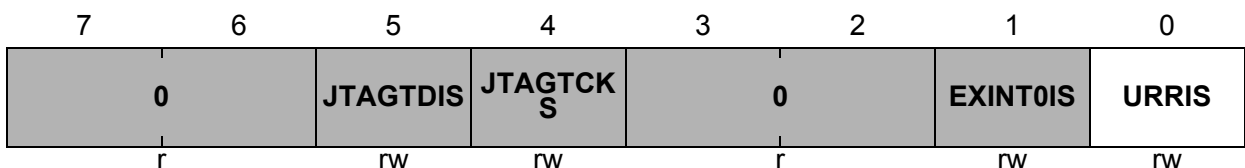

The functions of the shaded bits are not described here

Field	Bits	Type	Description
URRIS	0	rw	<p>UART Receive Input Select 0 UART Receiver Input RXD_0 is selected. 1 UART Receiver Input RXD_1 is selected.</p>

10.2 LIN

The UART can be used to support the Local Interconnect Network (LIN) protocol for both master and slave operations. The LIN baud rate detection feature provides the capability to detect the baud rate within LIN protocol using Timer 2. This allows the UART to be synchronized to the LIN baud rate for data transmission and reception.

10.2.1 LIN Protocol

LIN is a holistic communication concept for local interconnected networks in vehicles. The communication is based on the SCI (UART) data format, a single-master/multiple-slave concept, a clock synchronization for nodes without stabilized time base. An attractive feature of LIN is self-synchronization of the slave nodes without a crystal or ceramic resonator, which significantly reduces the cost of hardware platform. Hence, the baud rate must be calculated and returned with every message frame.

The structure of a LIN frame is shown in [Figure 10-4](#). The frame consists of the:

- header, which comprises a Break (13-bit time low), Synch Byte (55_H), and ID field
- response time
- data bytes (according to UART protocol)
- checksum

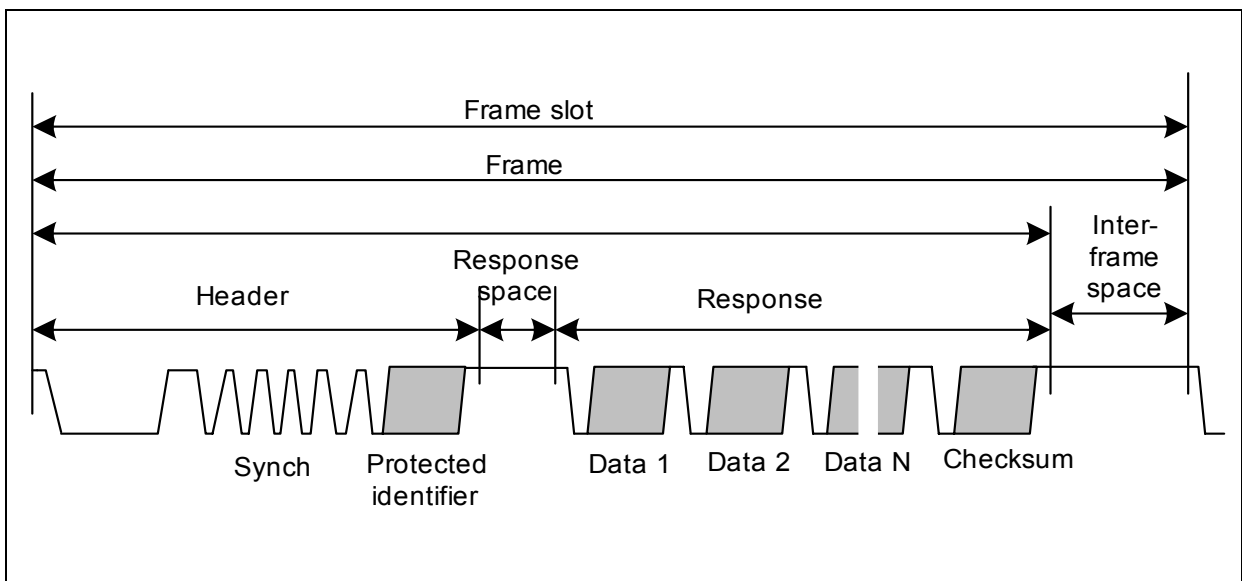

Figure 10-4 The Structure of LIN Frame

Each byte field is transmitted as a serial byte, as shown in [Figure 10-5](#). The LSB of the data is sent first and the MSB is sent last. The start bit is encoded as a bit with value zero (dominant) and the stop bit is encoded as a bit with value one (recessive).

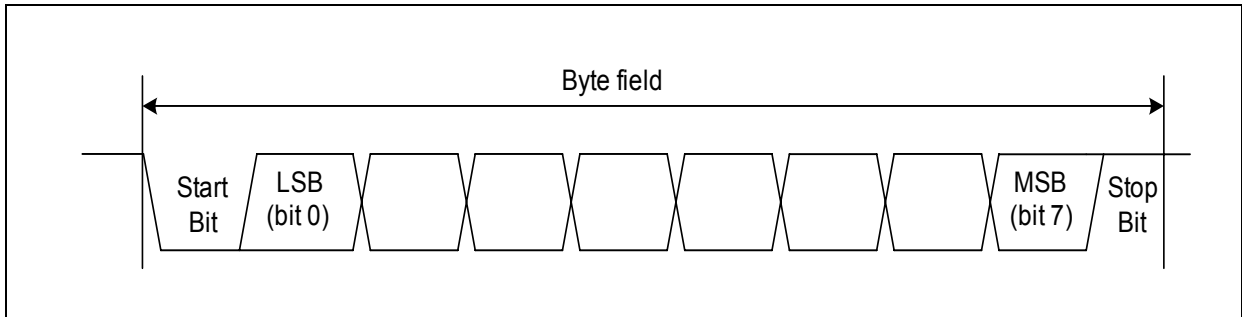

Figure 10-5 The Structure of Byte Field

The break is used to signal the beginning of a new frame. It is the only field that does not comply with **Figure 10-5**. A break is always generated by the master task (in the master mode) and it must be at least 13 bits of dominant value, including the start bit, followed by a break delimiter, as shown in **Figure 10-6**. The break delimiter will be at least one nominal bit time long.

A slave node will use a break detection threshold of 11 nominal bit times.

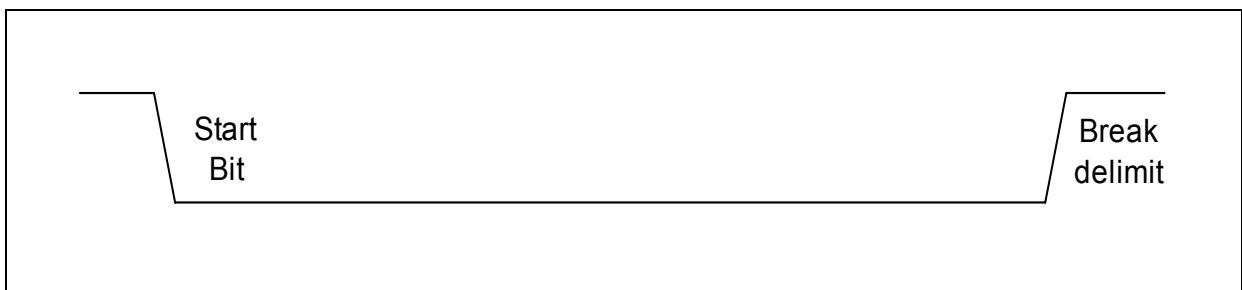

Figure 10-6 The Break Field

Synch Byte is a specific pattern for determination of time base. The byte field is with the data value 55_H, as shown in **Figure 10-7**.

A slave task is always able to detect the Break/Synch sequence, even if it expects a byte field (assuming the byte fields are separated from each other). If this happens, detection of the Break/Synch sequence will abort the transfer in progress and processing of the new frame will commence.

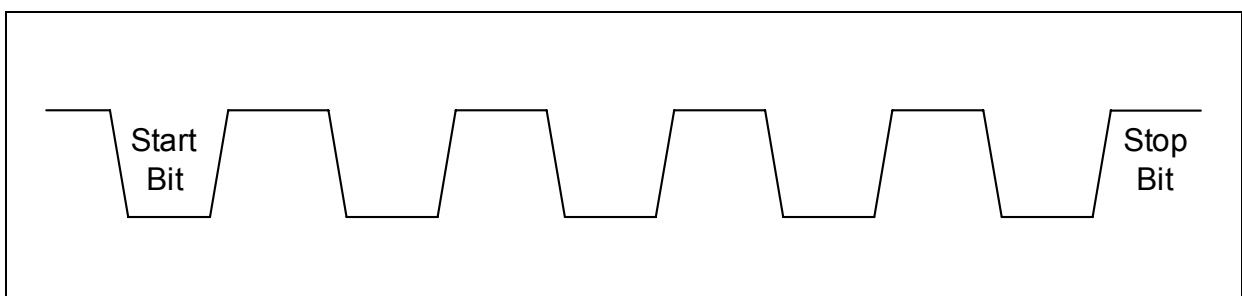

Figure 10-7 The Synch Byte Field

The slave task will receive and transmit data when an appropriate ID is sent by the master:

1. Slave waits for Synch Break
2. Slave synchronizes on Synch Byte
3. Slave snoops for ID
4. According to ID, slave determines whether to receive or transmit data, or do nothing
5. When transmitting, the slave sends 2, 4 or 8 data bytes, followed by check byte

10.2.2 LIN Header Transmission

LIN header transmission is only applicable in master mode. In the LIN communication, a master task decides when and which frame is to be transferred on the bus. It also identifies a slave task to provide the data transported by each frame. The information needed for the handshaking between the master and slave tasks is provided by the master task through the header portion of the frame.

The header consists of a break and synch pattern followed by an identifier. Among these three fields, only the break pattern cannot be transmitted as a normal 8-bit UART data. The break must contain a dominant value of 13 bits or more to ensure proper synchronization of slave nodes.

The UART can be used to transmit a 20-bit break field by the following sequence:

Step 1: Set the UART to mode 1:

- This configures the UART as an 8-bit UART with a variable baud rate.

Step 2: Set the baud rate to two times of the desired baud rate

Step 3: Write 00_H to the transmit buffer to begin transmission

By having two times of the desired baud rate, the 10-bit UART frame consisting of the start, stop and 8 data bits will achieve the effect of a 20-bit break field on the LIN bus. For subsequent synch and identifier fields, the baud rate must then be adjusted back to the initial value.

10.2.3 Baud Rate Detection of LIN

In the LIN communication, a slave task is required to be synchronized at the beginning of the protected identifier field of frame. For this purpose, every frame starts with a sequence consisting of a break field followed by a synch byte field. This sequence is unique and provides enough information for any slave task to detect the beginning of a new frame and be synchronized at the start of the identifier field.

In order to detect the baud rate of LIN, the bit timing T_{bit} is calculated by measuring the time between the falling edges of pattern. In baud rate detection mode, the timing of the two bits in Synch Byte field is captured, which is shown in [Figure 10-8](#).

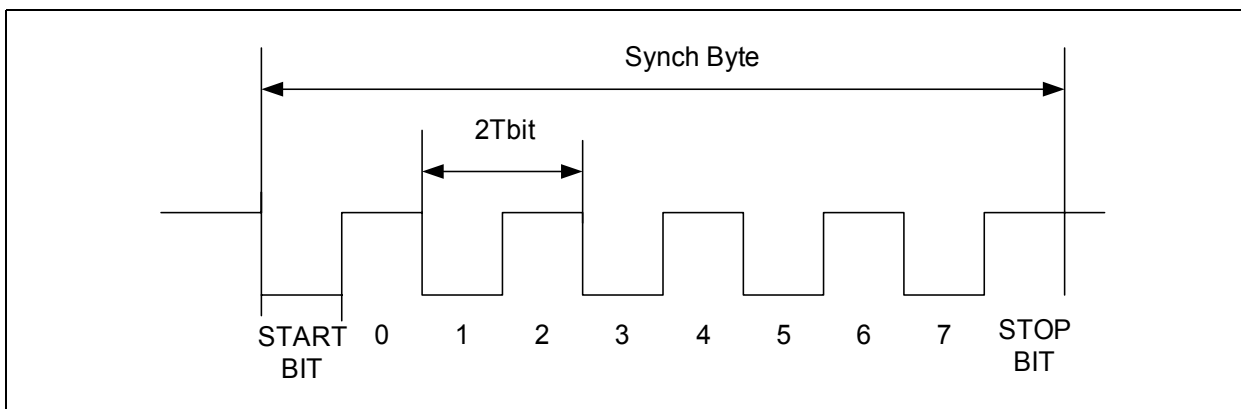

Figure 10-8 The Bit Timing in Synch Byte

Register bits 4-7 of BCON register (see [Page 10-12](#)) are used for the LIN baud rate detection. Register bit BRDIS is used to enable/disable the baud rate detection. Register bit T2EXIS is used to choose the T2EX pin (P1.0) for the baud rate detection purpose or for the normal Timer 2 function use. Users should specify the baud rate range via the register bit BGSEL if they know the range of the LIN baud rate. The baud rate detection unit will use different sampling rates for different baud rates according to this information. This will result in accurate baud rate detection.

The following sequence is generally executed to start the baud rate detection:

Step1: With the first falling edge of RXD:

- If the system is in the power-down mode and PMCON0.WS = 01, a wake-up from the power-down through the RXD pin will be activated.
- Once the system enters normal mode, the following settings must be done by software:
 - Bit PMCON1.T2_DIS is set to 0 (enable Timer 2)
 - Bit BCON.BRDIS is set to 0 (enable baud rate detection)
 - Bit BCON.T2EXIS is set to 0 (T2EX pin is used for baud rate detection)
 - Provide the baud rate range via bit BCON.BGSEL
 - Bits T2CON.CP/RL2 and T2CON.EXEN2 are set to 1. T2MOD.EDGESEL is set to 0. (Timer 2 is set to the capture mode with falling edge trigger)

- The UART is running with an estimated baud rate, which is generated by the baud-rate generator. (See [Section 10.1.4.1](#))

Step 2: With the second falling edge of Synch Byte:

- Start Timer 2 by hardware (Bit 1 of Synch Byte field).

Step 3: With the third falling edge of Synch Byte:

- The capture action of Timer 2 will be triggered and lead to a capture of the time of bit 1 and bit 2 in Synch Byte field. The contents of the timer register (THL2) are captured into the RC2 register. The captured value is 2 LIN bit times long. If the capture signal is detected while the counter is being incremented, the counter is first incremented before the capture operation is performed. This ensures that the latest value of the timer register is always captured.
- When the capture operation is completed, bit T2CON.EXF2 is set and can be used to generate an interrupt request.
- The software will use the RC2 value of Timer 2 to retrieve the reload value BG_VALUE and prescaler BRPRE of the baud-rate generator.
- The software updates the baud-rate generator with the new BG value and prescaler value, and generates the new baud rate.

The reload register of Timer 2 (RC2) is reloaded with value 0000_H by software.

10.3 High-Speed Synchronous Serial Interface

The SSC supports full-duplex and half-duplex synchronous communication. The serial clock signal can be generated by the SSC internally (master mode), using its own 16-bit baud-rate generator, or can be received from an external master (slave mode). Data width, shift direction, clock polarity and phase are programmable. This allows communication with SPI-compatible devices or devices using other synchronous serial interfaces.

Data is transmitted or received on lines TXD and RXD, which are normally connected to the pins MTSR (Master Transmit/Slave Receive) and MRST (Master Receive/Slave Transmit). The clock signal is output via line MS_CLK (Master Serial Shift Clock) or input via line SS_CLK (Slave Serial Shift Clock). Both lines are normally connected to the pin SCLK. Transmission and reception of data are double-buffered.

Figure 10-9 shows the block diagram of the SSC.

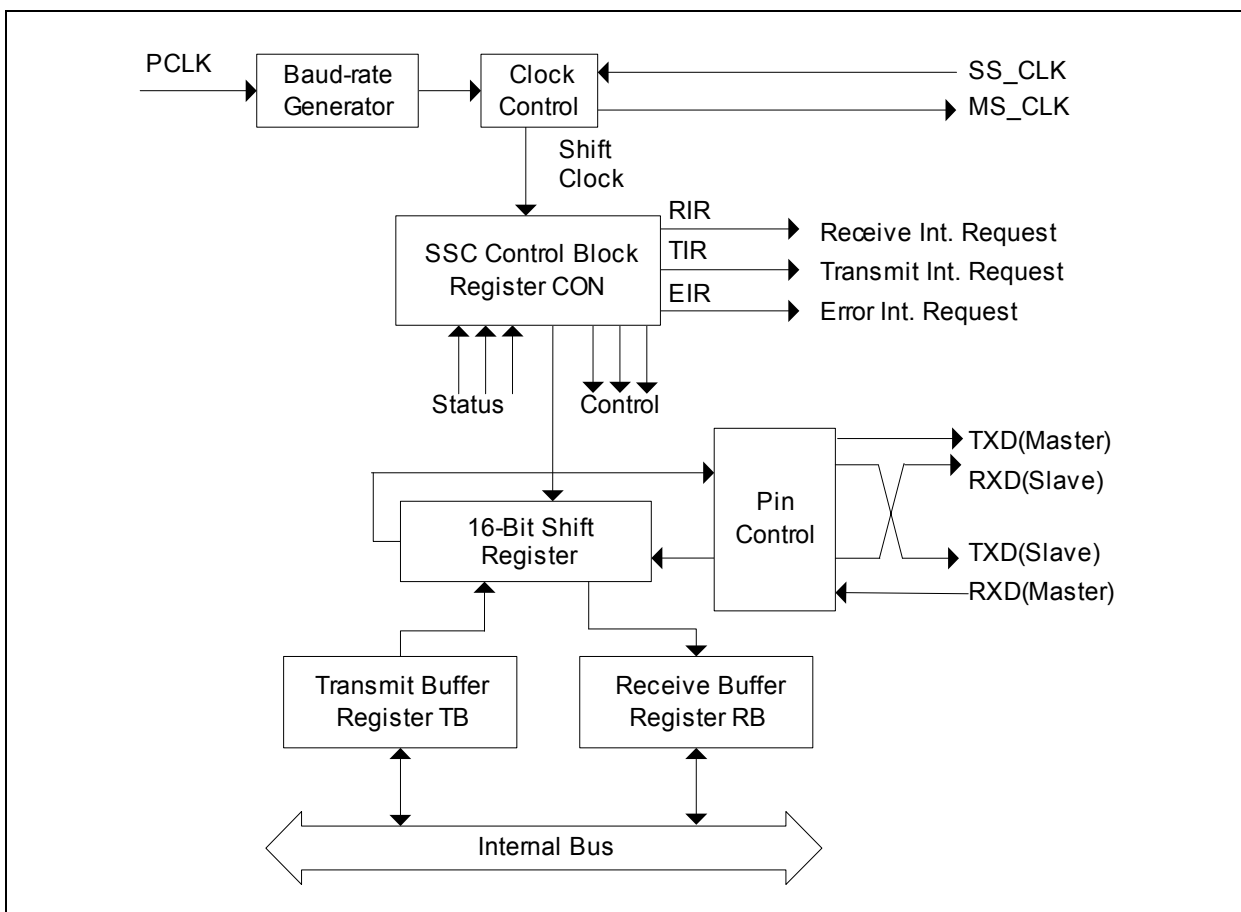

Figure 10-9 Synchronous Serial Channel SSC Block Diagram

10.3.1 General Operation

10.3.1.1 Operating Mode Selection

The operating mode of the serial channel SSC is controlled by its control register CON. This register has a double function:

- During programming (SSC disabled by CON.EN = 0), it provides access to a set of control bits
- During operation (SSC enabled by CON.EN = 1), it provides access to a set of status flags.

The shift register of the SSC is connected to both the transmit lines and the receive lines via the pin control logic. Transmission and reception of serial data are synchronized and take place at the same time, i.e., the same number of transmitted bits is also received. Transmit data is written into the Transmitter Buffer register (TB) and is moved to the shift register as soon as this is empty. An SSC master (CON.MS = 1) immediately begins transmitting, while an SSC slave (CON.MS = 0) will wait for an active shift clock. When the transfer starts, the busy flag CON.BSY is set and the Transmit Interrupt Request line (TIR) will be activated to indicate that register TB may be reloaded again. When the programmed number of bits (2...8) have been transferred, the contents of the shift register are moved to the Receiver Buffer register (RB) and the Receive Interrupt Request line (RIR) will be activated. If no further transfer is to take place (TB is empty), CON.BSY will be cleared at the same time. Software should not modify CON.BSY, as this flag is hardware controlled.

Note: Only one SSC can be the master at a given time.

The transfer of serial data bits can be programmed in a number of ways:

- The data width can be specified from 2 to 8 bits
- A transfer may start with either the LSB or the MSB
- The shift clock may be idle low or idle high
- The data bits may be shifted with the leading edge or the trailing edge of the shift clock signal
- The baud rate may be set within a certain range depending on the module clock
- The shift clock can be generated (MS_CLK) or can be received (SS_CLK)

These features allow the SSC to be adapted to a wide range of applications requiring serial data transfer.

The Data Width Selection supports the transfer of frames of any data length, from 2-bit "characters" up to 8-bit "characters". Starting with the LSB (CON.HB = 0) allows communication with SSC devices in synchronous mode or with serial interfaces such as the one in 8051. Starting with the MSB (CON.HB = 1) allows operation compatible with the SPI interface.

Regardless of the data width selected and whether the MSB or the LSB is transmitted first, the transfer data is always right-aligned in registers TB and RB, with the LSB of the

transfer data in bit 0 of these registers. The data bits are rearranged for transfer by the internal shift register logic. The unselected bits of TB are ignored; the unselected bits of RB will not be valid and should be ignored by the receiver service routine.

The Clock Control allows the transmit and receive behavior of the SSC to be adapted to a variety of serial interfaces. A specific shift clock edge (rising or falling) is used to shift out transmit data, while the other shift clock edge is used to latch in receive data. Bit CON.PH selects the leading edge or the trailing edge for each function. Bit CON.PO selects the level of the shift clock line in the idle state. Thus, for an idle-high clock, the leading edge is a falling one, a 1 - to - 0 transition (see [Figure 10-10](#)).

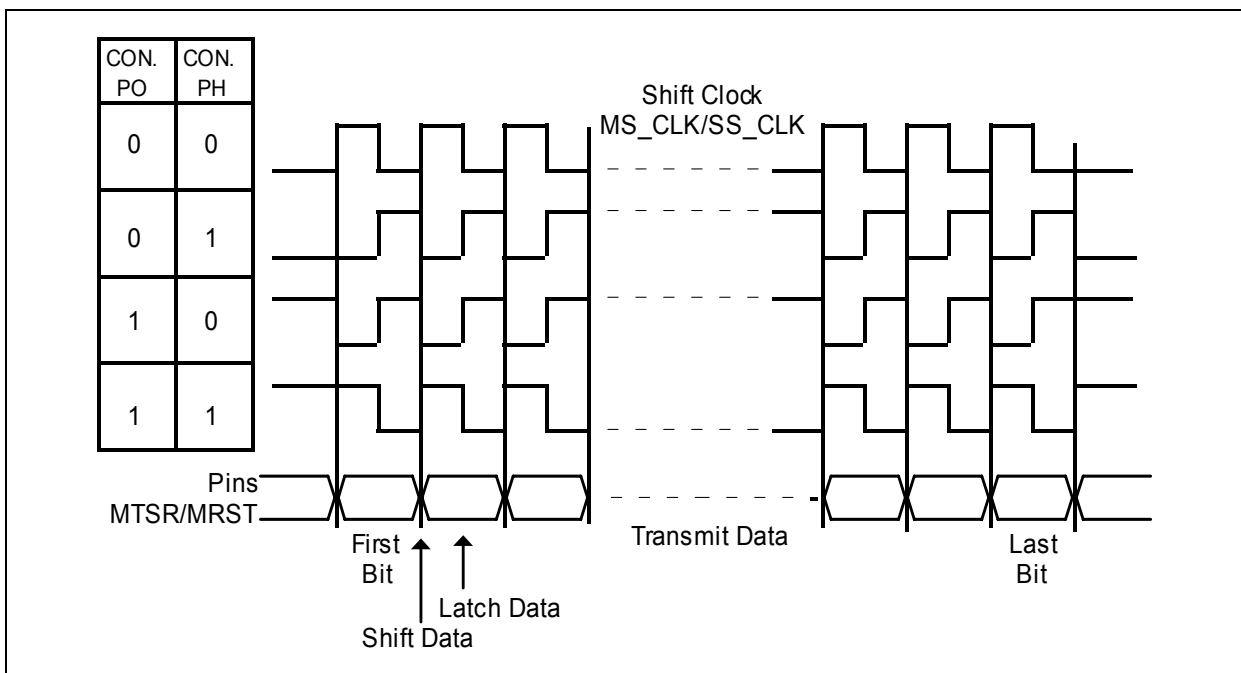

Figure 10-10 Serial Clock Phase and Polarity Options

When initializing the devices for serial communication, one device must be selected for master operation while all other devices must be programmed for slave operation.

10.3.1.2 Full-Duplex Operation

The various devices are connected through three lines. The definition of these lines is always determined by the master: the line connected to the master's data output line TXD is the transmit line; the receive line is connected to its data input line RXD; the shift clock line is either MS_CLK or SS_CLK. Only the device selected for master operation generates and outputs the shift clock on line MS_CLK. Since all slaves receive this clock, their pin SCLK must be switched to input mode. The external connections are hard-wired, and the function and direction of these pins are determined by the master or slave operation of the individual device.

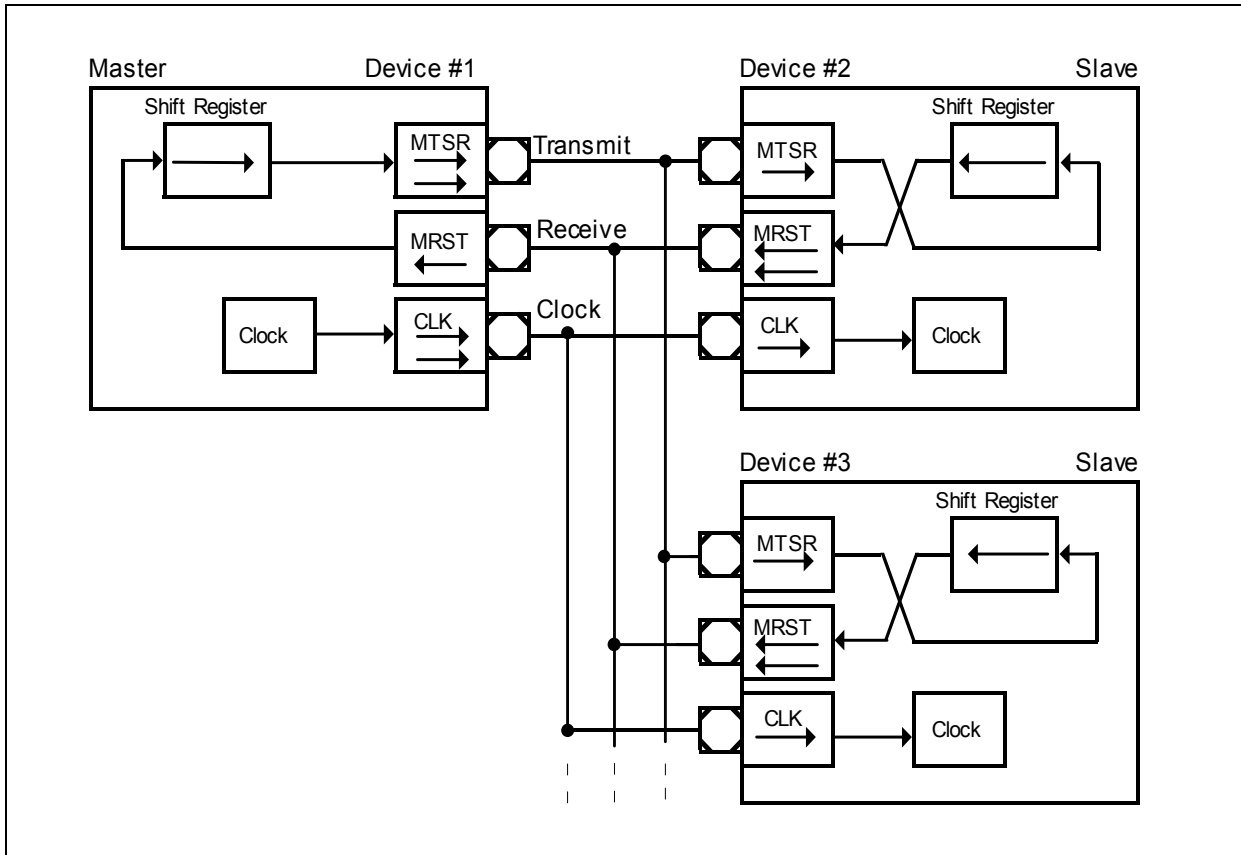

Figure 10-11 SSC Full-Duplex Configuration

The data output pins MRST of all slave devices are connected together onto the single receive line in the configuration shown in **Figure 10-11**. During a transfer, each slave shifts out data from its shift register. There are two ways to avoid collisions on the receive line due to different slave data:

- Only one slave drives the line, i.e., enables the driver of its MRST pin. All the other slaves must have their MRST pins programmed as input so only one slave can put its data onto the master's receive line. Only the receiving of data from the master is possible. The master selects the slave device from which it expects data either by separate select lines, or by sending a special command to this slave. The selected slave then switches its MRST line to output until it gets a de-selection signal or command.
- The slaves use open drain output on MRST. This forms a wired-AND connection. The receive line needs an external pull-up in this case. Corruption of the data on the receive line sent by the selected slave is avoided when all slaves not selected for transmission to the master send ones only. Because this high level is not actively driven onto the line, but only held through the pull-up device, the selected slave can pull this line actively to a low level when transmitting a zero bit. The master selects the

Serial Interfaces

slave device from which it expects data either by separate select lines or by sending a special command to this slave.

After performing the necessary initialization of the SSC, the serial interfaces can be enabled. For a master device, the clock line will now go to its programmed polarity. The data line will go to either 0 or 1 until the first transfer starts. After a transfer, the data line will always remain at the logic level of the last transmitted data bit.

When the serial interfaces are enabled, the master device can initiate the first data transfer by writing the transmit data into register TB. This value is copied into the shift register (assumed to be empty at this time), and the selected first bit of the transmit data will be placed onto the TXD line on the next clock from the baud-rate generator (transmission starts only if CON.EN = 1). Depending on the selected clock phase, a clock pulse will also be generated on the MS_CLK line. At the same time, with the opposite clock edge, the master latches and shifts in the data detected at its input line RXD. This “exchanges” the transmit data with the receive data. Because the clock line is connected to all slaves, their shift registers will be shifted synchronously with the master’s shift register—shifting out the data contained in the registers, and shifting in the data detected at the input line.

With the start of the transfer, the busy flag CON.BSY is set and the TIR will be activated to indicate that register TB may be reloaded again. After the preprogrammed number of clock pulses (via the data width selection), the data transmitted by the master is contained in all the slaves’ shift registers, while the master’s shift register holds the data of the selected slave. In the master and all slaves, the contents of the shift register are copied into the receive buffer RB and the RIR is activated. If no further transfer is to take place (TB is empty), CON.BSY will be cleared at the same time. Software should not modify CON.BSY, as this flag is hardware controlled.

When configured as a slave device, the SSC will immediately output the selected first bit (MSB or LSB of the transfer data) at the output pin once the contents of the transmit buffer are copied into the slave's shift register. Bit CON.BSY is not set until the first clock edge at SS_CLK appears.

Note: On the SSC, a transmission and a reception take place at the same time, regardless of whether valid data has been transmitted or received.

Note: The initialization of the CLK pin on the master requires some attention in order to avoid undesired clock transitions, which may disturb the other devices. Before the clock pin is switched to output via the related direction control register, the clock output level will be selected in the control register CON and the alternate output be prepared via the related ALTSEL register, or the output latch must be loaded with the clock idle level.

10.3.1.3 Half-Duplex Operation

In a half-duplex mode, only one data line is necessary for both receiving and transmitting of data. The data exchange line is connected to both the MTSR and MRST pins of each device, the shift clock line is connected to the SCLK pin.

The master device controls the data transfer by generating the shift clock, while the slave devices receive it. Due to the fact that all transmit and receive pins are connected to one data exchange line, serial data may be moved between arbitrary stations.

As in full-duplex mode, there are two ways to avoid collisions on the data exchange line:

- only the transmitting device may enable its transmit pin driver
- the non-transmitting devices use open drain output and send only ones.

Since the data inputs and outputs are connected together, a transmitting device will clock in its own data at the input pin (MRST for a master device, MTSR for a slave). By this method, any corruptions on the common data exchange line are detected if the received data is not equal to the transmitted data.

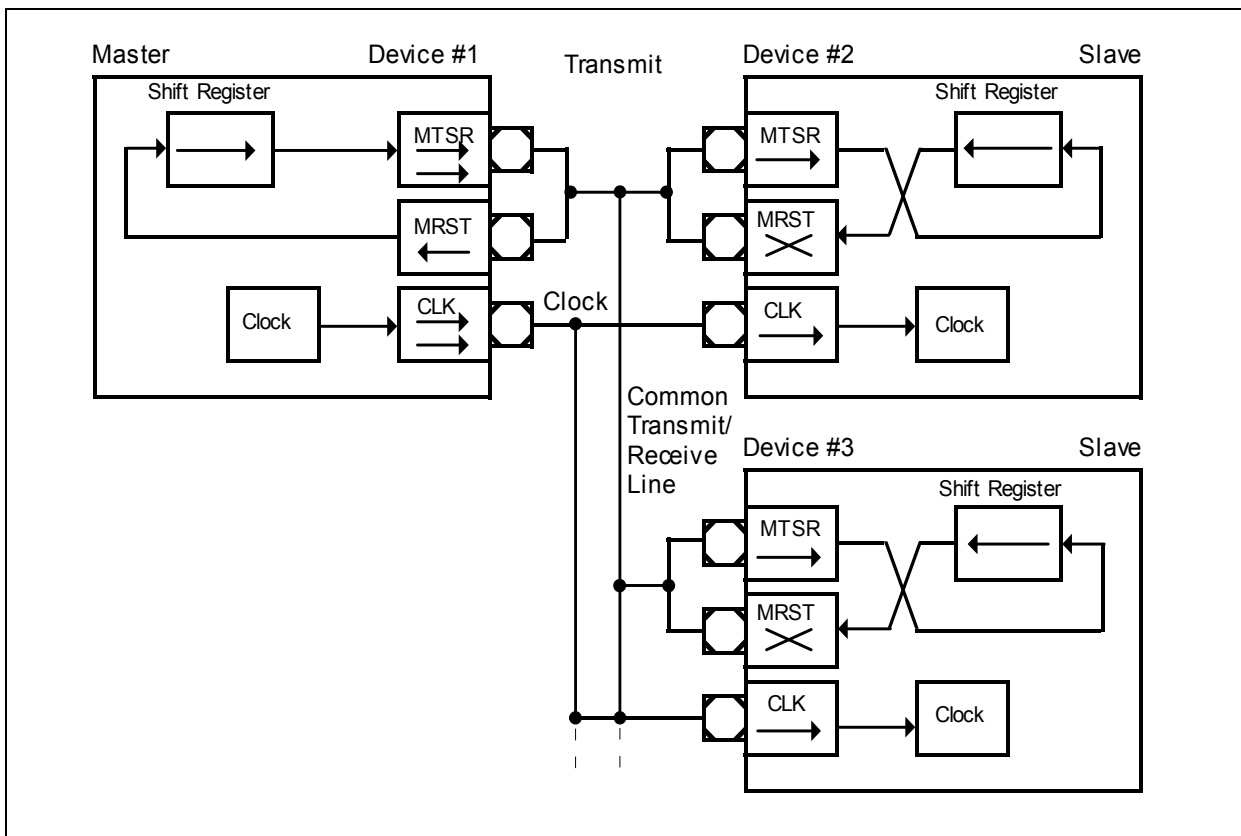

Figure 10-12 SSC Half-Duplex Configuration

10.3.1.4 Continuous Transfers

When the transmit interrupt request flag is set, it indicates that the transmit buffer TB is empty and ready to be loaded with the next transmit data. If TB has been reloaded by the time the current transmission is finished, the data is immediately transferred to the shift register and the next transmission will start without any additional delay. On the data line, there is no gap between the two successive frames. For example, two byte transfers would look the same as one word transfer. This feature can be used to interface with devices that can operate with or require more than 8 data bits per transfer. It is just a matter of software specifying the total data frame length. This option can also be used to interface with byte-wide and word-wide devices.

Note: This feature allows only multiples of the selected basic data width, because it would require disabling/enabling of the SSC to reprogram the basic data width on-the-fly.

10.3.1.5 Port Control

The SSC uses three lines to communicate with the external world as shown in [Figure 10-13](#). Pin SCLK serves as the clock line, while pins MRST and MTSR serve as the serial data input/output lines.

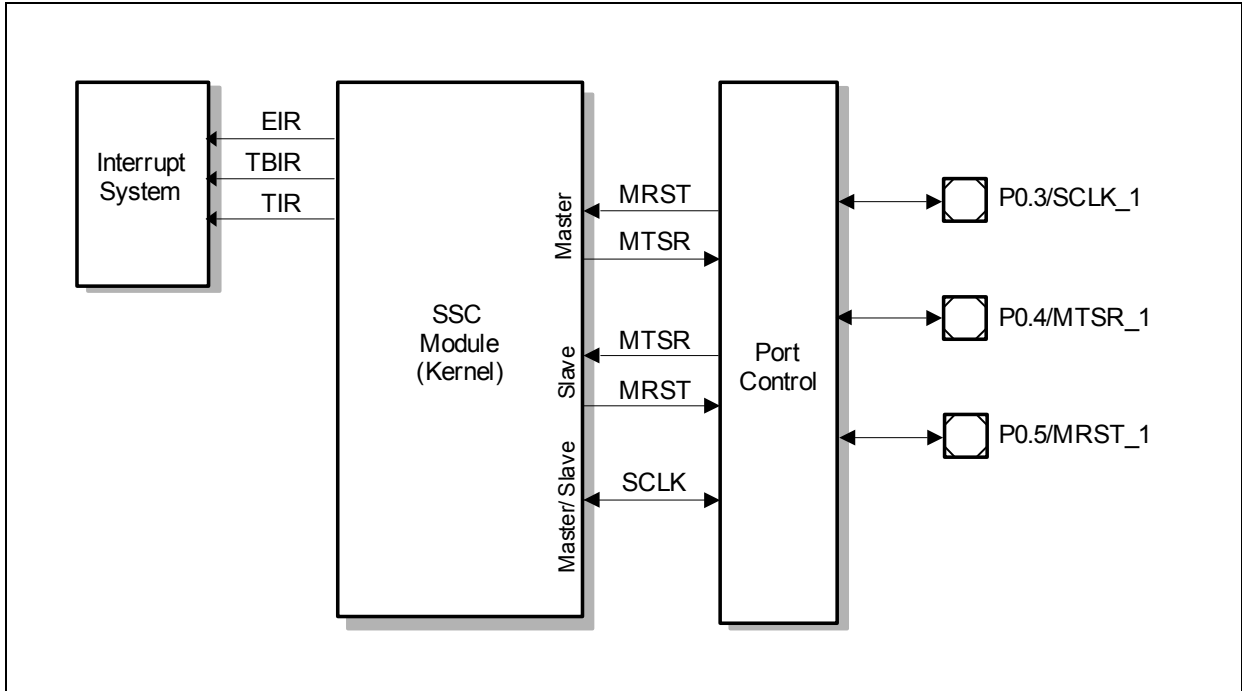

Figure 10-13 SSC Module I/O Interface

Operation of the SSC I/O lines depends on the selected operating mode (master or slave). The direction of the port lines depends on the operating mode. The SSC will

automatically use the correct kernel output or kernel input line of the ports when switching modes.

Since the SSC I/O lines are connected with the bidirectional lines of the general purpose I/O ports, software I/O control is used to control the port pins assigned to these lines. The port registers must be programmed for alternate output and input selection. When switching between master and slave modes, port registers must be reprogrammed.

10.3.1.6 Baud Rate Generation

The serial channel SSC has its own dedicated 16-bit baud-rate generator with 16-bit reload capability, allowing baud rate generation independent of the timers. [Figure 10-14](#) shows the baud-rate generator.

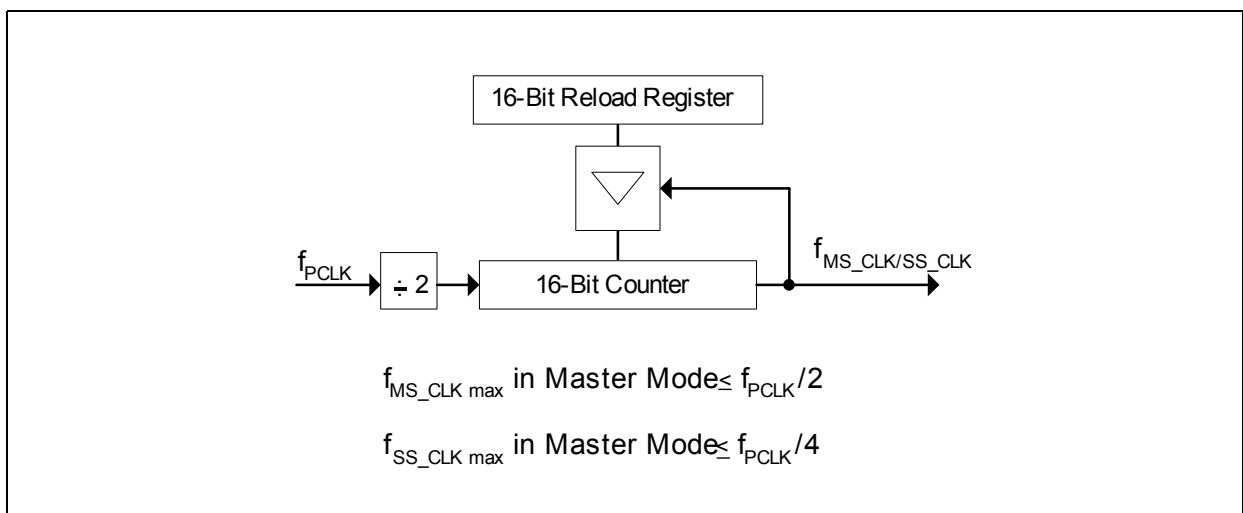

Figure 10-14 SSC Baud-rate Generator

The baud-rate generator is clocked with the module clock f_{PCLK} . The timer counts downwards. Register BR is the dual-function Baud-rate Generator/Reload register. Reading BR, while the SSC is enabled, returns the contents of the timer. Reading BR, while the SSC is disabled, returns the programmed reload value. In this mode, the desired reload value can be written to BR.

Note: Never write to BR while the SSC is enabled.

The formulas below calculate either the resulting baud rate for a given reload value, or the required reload value for a given baud rate:

$$\text{Baud rate} = \frac{f_{PCLK}}{2 \times (
 + 1)} \qquad BR = \frac{f_{PCLK}}{2 \times \text{Baud rate}} - 1$$

 represents the contents of the reload register, taken as an unsigned 16-bit integer, while baud rate is equal to f_{MS_CLK/SS_CLK} as shown in [Figure 10-14](#).

The maximum baud rate that can be achieved when using a module clock of 26.7 MHz is 13.3 MBaud in master mode (with $\langle BR \rangle = 0000_H$) or 6.7 MBaud in slave mode (with $\langle BR \rangle = 0001_H$).

Table 10-3 lists some possible baud rates together with the required reload values and the resulting deviation errors, assuming a module clock frequency of 26.7 MHz.

Table 10-3 Typical Baud Rates of the SSC ($f_{hw_clk} = 26.7$ MHz)

Reload Value	Baud Rate (= f_{MS_CLK/SS_CLK})	Deviation
0000 _H	13.3 MBaud (only in Master mode)	0.0%
0001 _H	6.7 MBaud	0.0%
0009 _H	1.3 MBaud	0.0%
000C _H	1 MBaud	2.5%
0011 _H	750 kBaud	1.2%
0013 _H	666.7 kBaud	0.0%
0015 _H	600 kBaud	1.0%
001A _H	500 kBaud	1.2%
0031 _H	266.7 kBaud	0.0%
0042 _H	200 kBaud	0.5%
0063 _H	133.3 kBaud	0.0%
0084 _H	100 kBaud	0.25%
FFFF _H	203.45 Baud	0.0%

10.3.1.7 Error Detection Mechanisms

The SSC is able to detect four different error conditions. Receive Error and Phase Error are detected in all modes; Transmit Error and Baud Rate Error apply only to slave mode. When an error is detected, the respective error flag is set and an error interrupt request will be generated by activating the Error Interrupt Request line (EIR) (see [Figure 10-15](#)). The error interrupt handler may then check the error flags to determine the cause of the error interrupt. The error flags are not reset automatically, but rather must be cleared by software after servicing. This allows servicing of some error conditions via interrupt, while the others may be polled by software.

Note: The error interrupt handler must clear the associated (enabled) error flag(s) to prevent repeated interrupt requests.

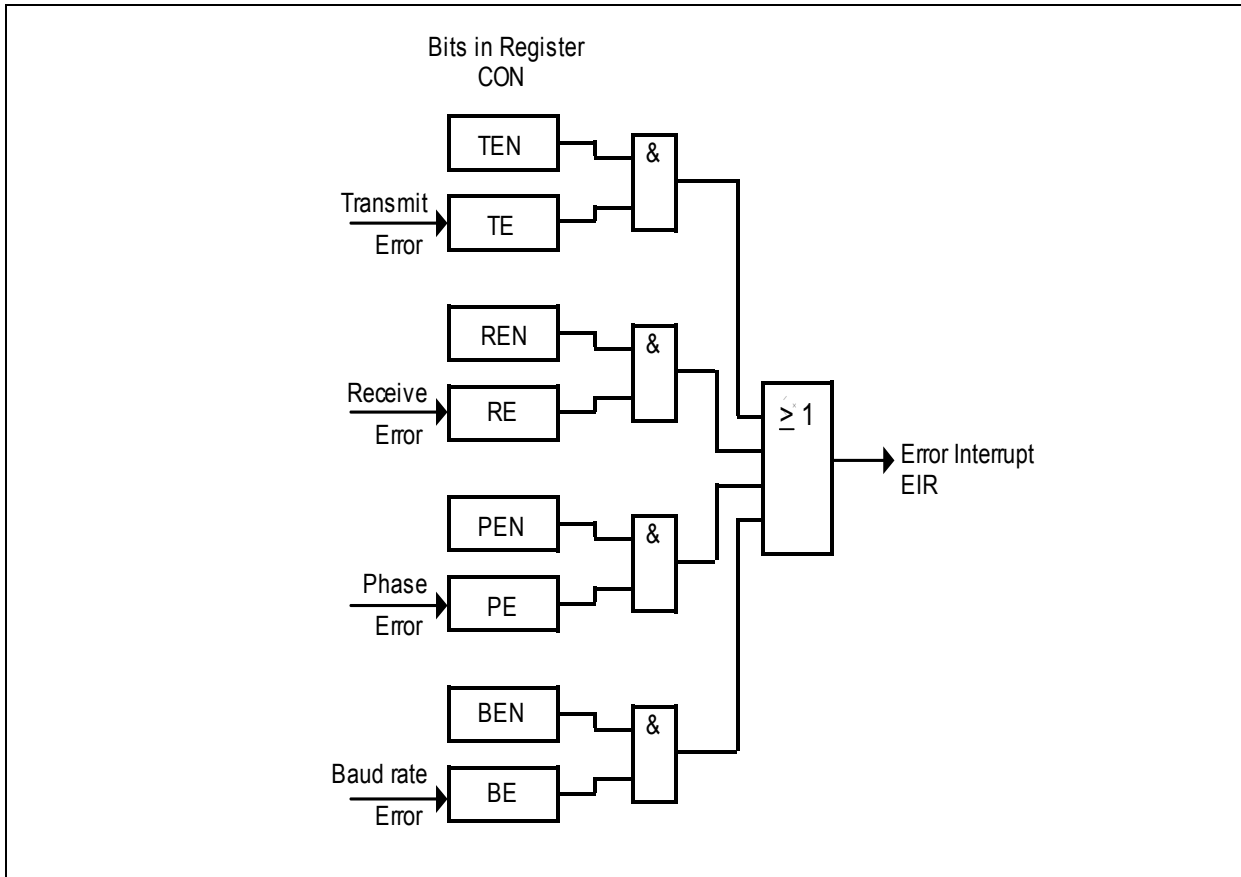

Figure 10-15 SSC Error Interrupt Control

A **Receive Error** (master or slave mode) is detected when a new data frame is completely received, but the previous data was not read out of the register RB. This condition sets the error flag CON.RE and, when enabled via CON.REN, sets the EIR. The old data in the receive buffer RB will be overwritten with the new value and this lost data is irretrievable.

A **Phase Error** (master or slave mode) is detected when the incoming data at pin MRST (master mode) or MTSR (slave mode), sampled with the same frequency as the module clock, changes between one cycle before and two cycles after the latching edge of the shift clock signal SCLK. This condition sets the error flag CON.PE and, when enabled via CON.PEN, sets the EIR.

A **Baud Rate Error** (slave mode) is detected when the incoming clock signal deviates from the programmed baud rate by more than 100%, i.e., it is either more than double or less than half the expected baud rate. This condition sets the error flag CON.BE and, when enabled via CON.BEN, sets the EIR. Using this error detection capability requires that the slave's baud-rate generator be programmed to the same baud rate as the master device. This feature detects false, additional or missing pulses on the clock line (within a certain frame).

Note: If this error condition occurs and bit CON.REN = 1, an automatic reset of the SSC will be performed. This is done to re-initialize the SSC if too few or too many clock pulses have been detected.

A **Transmit Error** (slave mode) is detected when a transfer was initiated by the master (SS_CLK gets active), but the transmit buffer TB of the slave had not been updated since the last transfer. This condition sets the error flag CON.TE and, when enabled via CON.TEN, sets the EIR. If a transfer starts without the transmit buffer having been updated, the slave will shift out the 'old' contents of the shift register, which normally is the data received during the last transfer. This may lead to corruption of the data on the transmit/receive line in half-duplex mode (open drain configuration) if this slave is not selected for transmission. This mode requires that slaves not selected for transmission only shift out ones; that is, their transmit buffers must be loaded with 'FFFF_H' prior to any transfer.

Note: A slave with push/pull output drivers not selected for transmission, will normally have its output drivers switched off. However, in order to avoid possible conflicts or misinterpretations, it is recommended to always load the slave's transmit buffer prior to any transfer.

The cause of an error interrupt request (receive, phase, baud rate or transmit error) can be identified by the error status flags in control register CON.

Note: In contrast to the EIR, the error status flags CON.TE, CON.RE, CON.PE, and CON.BE are not reset automatically upon entry into the error interrupt service routine, but must be cleared by software.

10.3.2 Interrupts

An overview of the various interrupts in SSC is provided in [Table 10-4](#).

Table 10-4 SSC Interrupt Sources

Interrupt	Signal	Description
Transmission starts	TIR	Indicates that the transmit buffer can be reloaded with new data.
Transmission ends	RIR	The configured number of bits have been transmitted and shifted to the receive buffer.
Receive Error	EIR	This interrupt occurs if a new data frame is completely received and the last data in the receive buffer was not read.
Phase Error	EIR	This interrupt is generated if the incoming data changes between one cycle before and two cycles after the latching edge of the shift clock signal SCLK.
Baud Rate Error (Slave mode only)	EIR	This interrupt is generated when the incoming clock signal deviates from the programmed baud rate by more than 100%.
Transmit Error (Slave mode only)	EIR	This interrupt is generated when TB was not updated since the last transfer if a transfer is initiated by a master.

10.3.3 Register Mapping

The addresses of the kernel SFRs are listed in [Table 10-5](#).

Table 10-5 SFR Address List

Address	Register
A9 _H	PISEL
AA _H	CONL
AB _H	CONH
AC _H	TBL
AD _H	RBL
AE _H	BRL
AF _H	BRH

10.3.4 Register Description

All SSC register names described in this section will be referenced in other chapters of this document with the module name prefix “SSC_”, e.g., SSC_PISEL.

10.3.4.1 Port Input Select Register

The PISEL register controls the receiver input selection of the SSC module.

PISEL

Port Input Select Register

Reset Value: 00_H

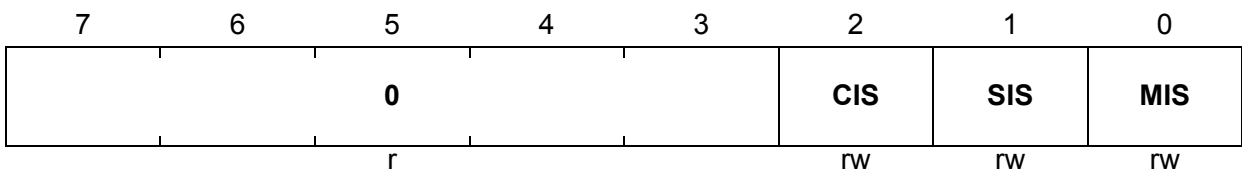

Field	Bits	Type	Description
MIS	0	rw	Master Mode Receiver Input Select 0 Receiver input is disabled for master mode. 1 Receiver input is enabled for master mode.
SIS	1	rw	Slave Mode Receiver Input Select 0 Receiver input is disabled for slave mode. 1 Receiver input is enabled for slave mode.
CIS	2	rw	Slave Mode Clock Input Select 0 Clock input is disabled. 1 Clock input is enabled.
0	[7:3]	r	Reserved Returns 0 if read; should be written with 0.

10.3.4.2 Configuration Register

The operating mode of the serial channel SSC is controlled by the control register CON. This register contains control bits for mode and error check selection, and status flags for error identification. Depending on bit EN, either control functions or status flags and master/slave control are enabled.

CON.EN = 0: Programming Mode

CONL

Control Register Low

Reset Value: 00_H

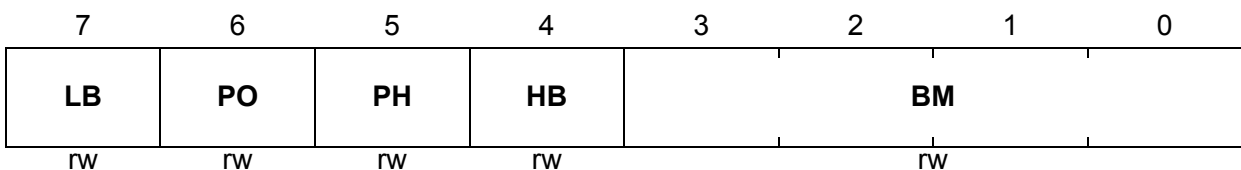

Field	Bits	Type	Description
BM	[3:0]	rw	Data Width Selection 0000 Reserved. Do not use this combination. 0001 - 0111 Transfer Data Width is 2...8 bits (<BM>+1) <i>Note: BM[3] is fixed to 0.</i>
HB	4	rw	Heading Control 0 Transmit/Receive LSB First 1 Transmit/Receive MSB First
PH	5	rw	Clock Phase Control 0 Shift transmit data on the leading clock edge, latch on trailing edge 1 Latch receive data on leading clock edge, shift on trailing edge
PO	6	rw	Clock Polarity Control 0 Idle clock line is low, leading clock edge is low-to-high transition 1 Idle clock line is high, leading clock edge is high-to-low transition
LB	7	rw	Loop Back Control 0 Normal output 1 Receive input is connected with transmit output (half-duplex mode)

CONH
Control Register High
Reset Value: 00_H

7	6	5	4	3	2	1	0
EN	MS	0	AREN	BEN	PEN	REN	TEN
rw	rw	r	rw	rw	rw	rw	rw

Field	Bits	Type	Description
TEN	0	rw	Transmit Error Enable 0 Ignore transmit errors 1 Check transmit errors
REN	1	rw	Receive Error Enable 0 Ignore receive errors 1 Check receive errors
PEN	2	rw	Phase Error Enable 0 Ignore phase errors 1 Check phase errors
BEN	3	rw	Baud Rate Error Enable 0 Ignore baud rate errors 1 Check baud rate errors
AREN	4	rw	Automatic Reset Enable 0 No additional action upon a baud rate error 1 The SSC is automatically reset upon a baud rate error.
MS	6	rw	Master Select 0 Slave mode. Operate on shift clock received via SCLK. 1 Master mode. Generate shift clock and output it via SCLK.
EN	7	rw	Enable Bit = 0 Transmission and reception disabled. Access to control bits.
0	5	r	Reserved Returns 0 if read; should be written with 0.

CON.EN = 1: Operating Mode

CONL

Control Register Low

Reset Value: 00_H

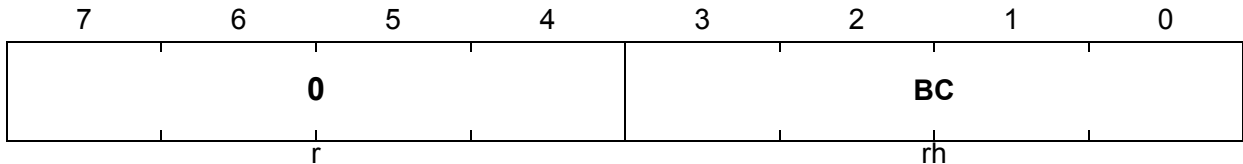

Field	Bits	Type	Description
BC	[3:0]	rh	Bit Count Field 0001 - 1111 Shift counter is updated with every shifted bit
0	[7:4]	r	Reserved Returns 0 if read; should be written with 0.

CONH

Control Register High

Reset Value: 00_H



Field	Bits	Type	Description
TE	0	rwh	Transmit Error Flag 0 No error 1 Transfer starts with the slave's transmit buffer not being updated
RE	1	rwh	Receive Error Flag 0 No error 1 Reception completed before the receive buffer was read
PE	2	rwh	Phase Error Flag 0 No error 1 Received data changes around sampling clock edge

Serial Interfaces

Field	Bits	Type	Description
BE	3	rwh	Baud rate Error Flag 0 No error 1 More than factor 2 or 0.5 between slave's actual and expected baud rate
BSY	4	rh	Busy Flag Set while a transfer is in progress
MS	6	rw	Master Select Bit 0 Slave mode. Operate on shift clock received via SCLK. 1 Master mode. Generate shift clock and output it via SCLK.
EN	7	rw	Enable Bit = 1 Transmission and reception enabled. Access to status flags and Master/Slave control.
0	5	r	Reserved Returns 0 if read; should be written with 0.

Note: The target of an access to CON (control bits or flags) is determined by the state of CON.EN prior to the access; that is, writing C057_H to CON in programming mode (CON.EN = 0) will initialize the SSC (CON.EN was 0) and then turn it on (CON.EN = 1). When writing to CON, ensure that reserved locations receive zeros.

10.3.4.3 Baud Rate Timer Reload Register

The SSC baud rate timer reload register BR contains the 16-bit reload value for the baud rate timer.

BRL

Baud Rate Timer Reload Register Low

Reset Value: 00_H

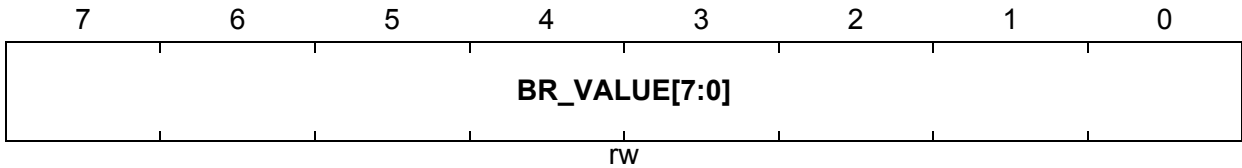

BRH

Baud Rate Timer Reload Register High

Reset Value: 00_H

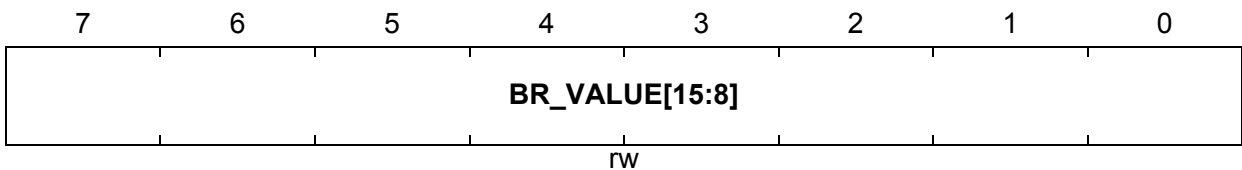

Field	Bits	Type	Description
BR_VALUE	[7:0] of BRL, [7:0] of BRH	rw	Baud Rate Timer/Reload Register Value Reading BR returns the 16-bit contents of the baud rate timer. Writing to BR loads the baud rate timer reload register with BR_VALUE.

10.3.4.4 Transmit and Receive Buffer Register

The SSC transmitter buffer register TB contains the transmit data value.

TBL

Transmitter Buffer Register Low

Reset Value: 00_H

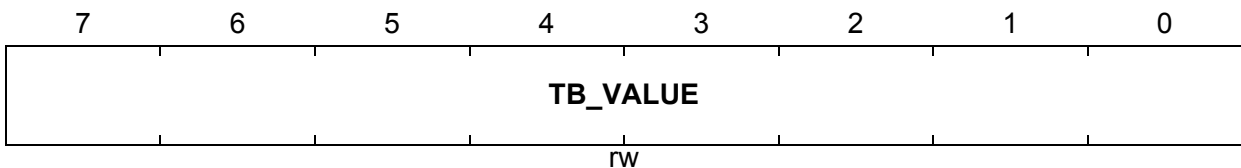

Field	Bits	Type	Description
TB_VALUE	[7:0]	rw	Transmit Data Register Value TB_VALUE is the data value to be transmitted. Unselected bits of TB are ignored during transmission.

The SSC receiver buffer register RB contains the receive data value.

RBL

Receiver Buffer Register Low

Reset Value: 00_H

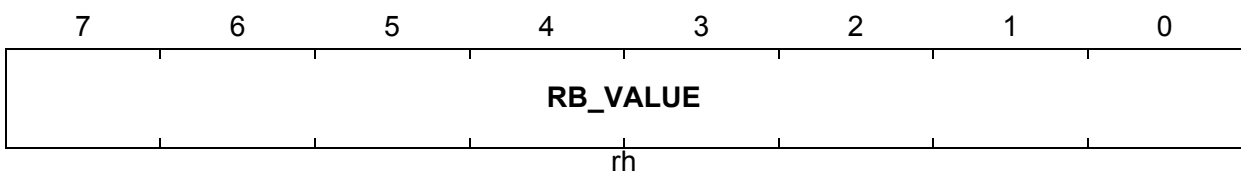

Field	Bits	Type	Description
RB_VALUE	[7:0]	rh	Receive Data Register Value RB contains the received data value RB_VALUE. Unselected bits of RB will not be valid and should be ignored.

11 Timers

The XC866 provides three 16-bit timers, Timer 0, Timer 1 and Timer 2. They are useful in many timing applications such as measuring the time interval between events and generating signals at regular intervals.

Timer 0 and Timer 1 Features:

- Four operational modes:
 - Mode 0: 13-bit timer
 - Mode 1: 16-bit timer
 - Mode 2: 8-bit timer with auto-reload
 - Mode 3: Two 8-bit timers

Timer 2 Features:

- Selectable up/down counting
- 16-bit auto-reload mode
- 1 channel, 16-bit capture mode

11.1 Timer 0 and Timer 1

Timer 0 and Timer 1 are count-up timers which are incremented every machine cycle, or in terms of the input clock, every 2 PCLK cycles. Both have four modes of operation that are used in a variety of applications.

11.1.1 Basic Timer Operations

The operations of the two timers are controlled using the Special Function Registers (SFRs) TCON and TMOD. To enable a timer, i.e., allow the timer to run, its control bit TCON.TR_x is set.

Note: The "x" (e.g., TCON.TR_x) in this chapter denotes either 0 or 1.

Each timer consists of two 8-bit registers, TL_x (low byte) and TH_x (high byte), which default to 00_H on reset. Setting or clearing TCON.TR_x does not affect the timer registers.

Timer Overflow

When a timer overflow occurs, the timer overflow flag TCON.TF_x is set, and an interrupt may be raised if the interrupt enable control bit IEN0.ET_x is set. The overflow flag is automatically cleared when the interrupt service routine is entered.

When Timer 0 operates in mode 3, the Timer 1 control bits TR1, TF1 and ET1 are reserved for TH0. See [Section 11.1.2.4](#).

External Control

In addition to pure software control, the timers can be enabled or disabled through external port control. When a timer is enabled (TCON.TRx = 1) and TMOD.GATE_x is set, the respective timer will only run if the core external interrupt EXINT_x = 1. This facilitates pulse width measurements. However, this is not applicable for Timer 1 in mode 3.

If TMOD.GATE_x is cleared, the timer reverts to pure software control.

11.1.2 Timer Modes

Timers 0 and 1 are fully compatible and can be configured in four different operating modes, as shown in [Table 11-1](#). The bit field TxM in register TMOD selects the operating mode to be used for each timer.

In modes 0, 1 and 2, the two timers operate independently, but in mode 3, their functions are specialized.

Table 11-1 Timer 0 and Timer 1 Modes

Mode	Operation
0	13-bit timer The timer is essentially an 8-bit counter with a divide-by-32 prescaler. This mode is included solely for compatibility with Intel 8048 devices.
1	16-bit timer The timer registers, TL _x and TH _x , are concatenated to form a 16-bit counter.
2	8-bit timer with auto-reload The timer register TL _x is reloaded with a user-defined 8-bit value in TH _x upon overflow.
3	Timer 0 operates as two 8-bit timers The timer registers, TL0 and TH0, operate as two separate 8-bit counters. Timer 1 is halted and retains its count even if enabled.

11.1.2.1 Mode 0

Putting either Timer 0 or Timer 1 into mode 0 configures it as an 8-bit timer with a divide-by-32 prescaler. **Figure 11-1** shows the mode 0 operation.

In this mode, the timer register is configured as a 13-bit register. As the count rolls over from all 1s to all 0s, it sets the timer overflow flag TFX. The overflow flag TFX can then be used to request an interrupt. The counted input is enabled for the timer when TRx = 1 and either GATEx = 0 or EXINTx = 1 (setting GATEx = 1 allows the timer to be controlled by external input EXINTx to facilitate pulse width measurements). TRx is a control bit in the register TCON; bit GATEx is in register TMOD.

The 13-bit register consists of all the 8 bits of THx and the lower 5 bits of TLx. The upper 3 bits of TLx are indeterminate and should be ignored. Setting the run flag (TRx) does not clear the registers.

Mode 0 operation is the same for Timer 0 and Timer 1.

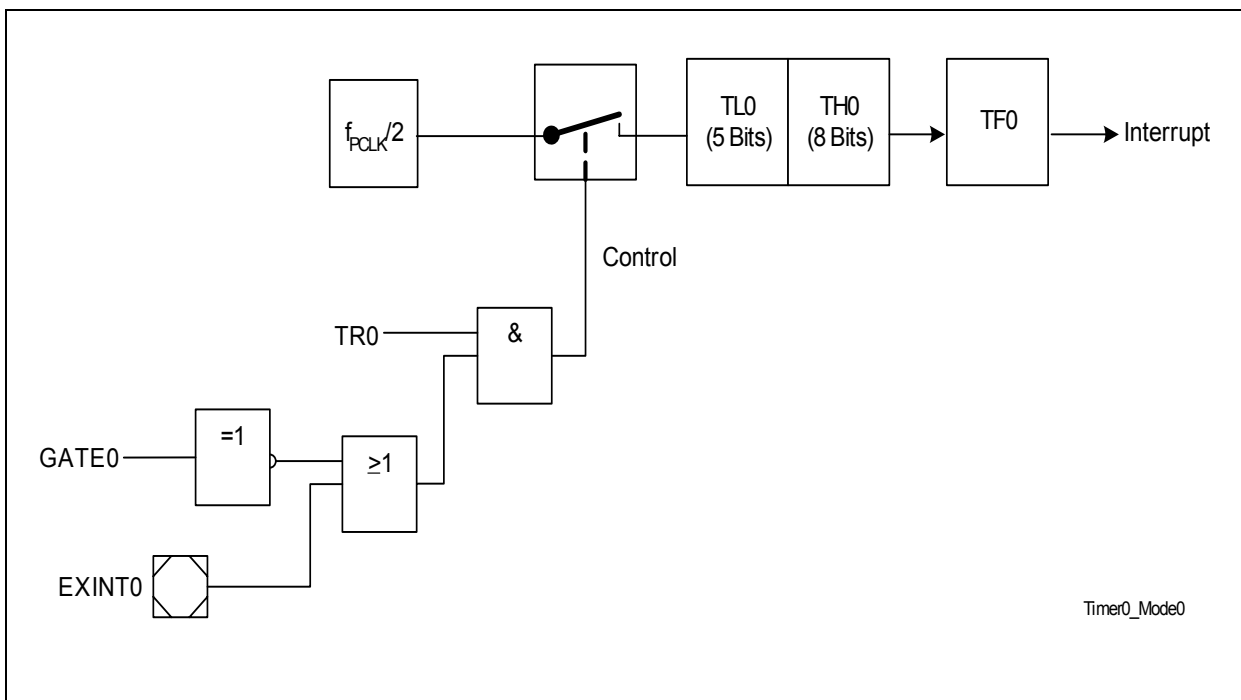

Figure 11-1 Timer 0, Mode 0: 13-bit Timer

11.1.2.2 Mode 1

Mode 1 operation is similar to that of mode 0, except that the timer register runs with all 16 bits. Mode 1 operation for Timer 0 is shown in **Figure 11-2**.

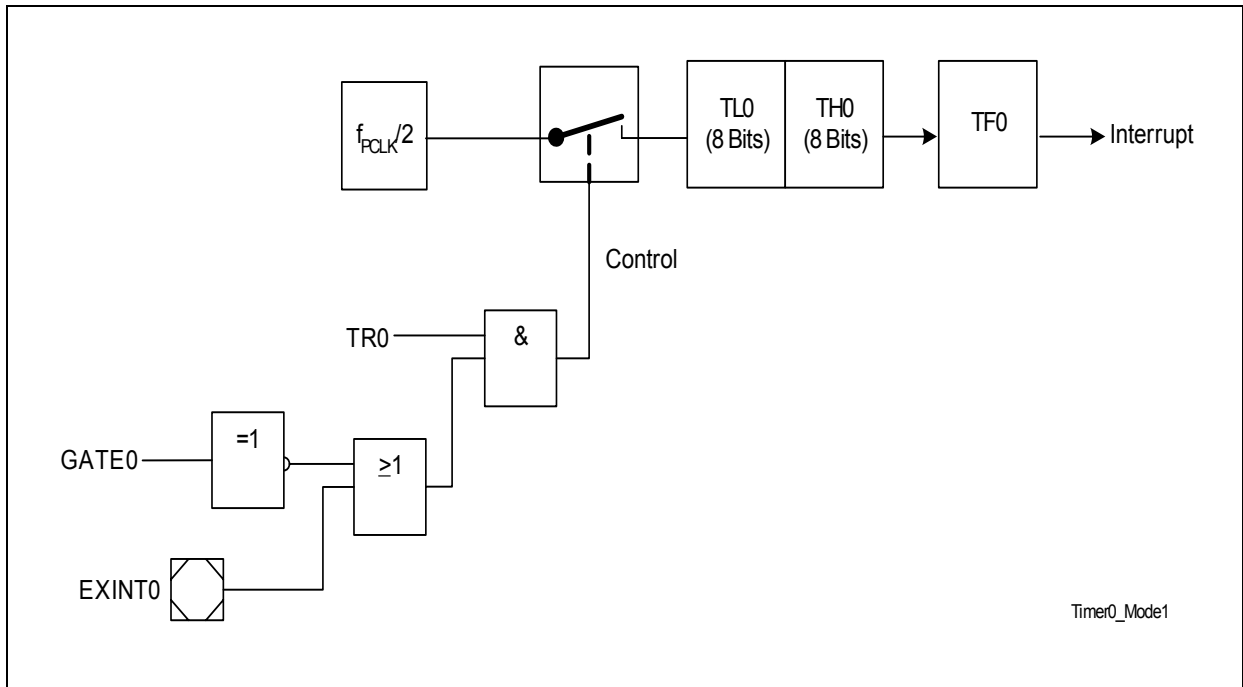

Figure 11-2 Timer 0, Mode 1: 16-bit Timer

11.1.2.3 Mode 2

In mode 2 operation, the timer is configured as an 8-bit counter (TLx) with automatic reload, as shown in **Figure 11-3** for Timer 0.

An overflow from TLx not only sets TFX, but also reloads TLx with the contents of THx that has been preset by software. The reload leaves THx unchanged.

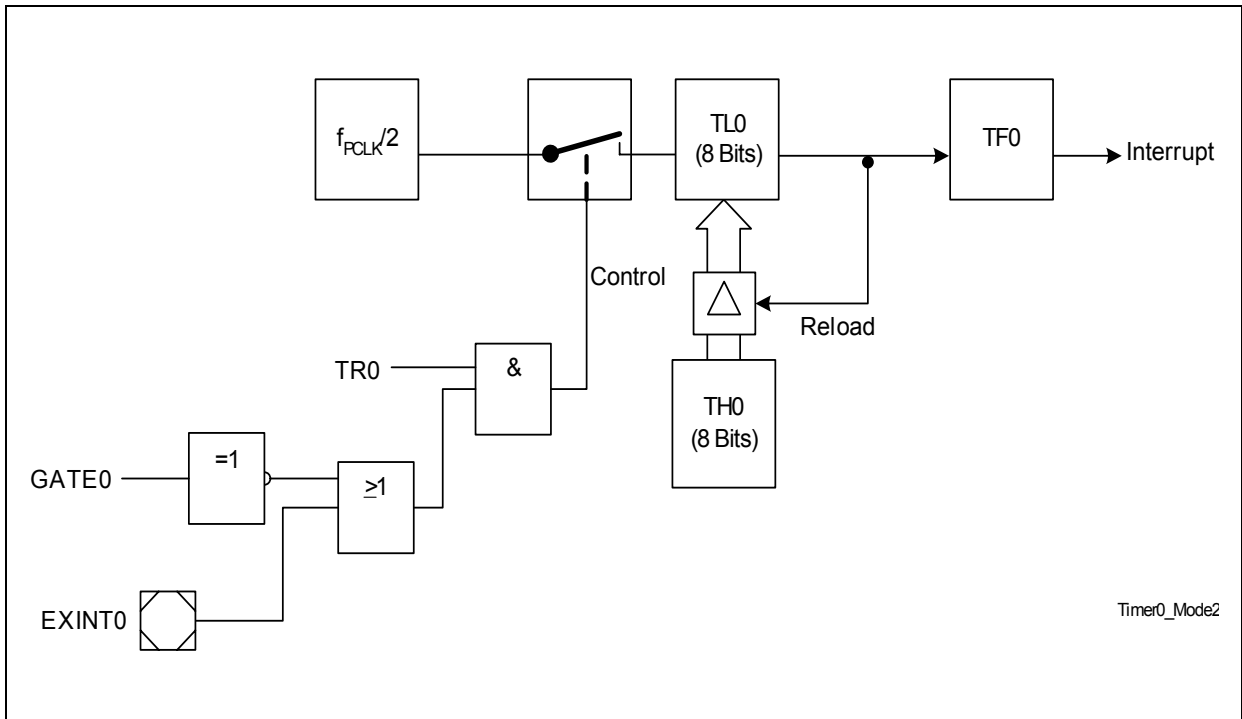

Figure 11-3 Timer 0, Mode 2: 8-bit Timer with Auto-Reload

11.1.2.4 Mode 3

In mode 3, Timer 0 and Timer 1 behave differently. Timer 0 in mode 3 establishes TL0 and TH0 as two separate counters. Timer 1 in mode 3 simply holds its count. The effect is the same as setting TR1 = 0.

The logic for mode 3 operation for Timer 0 is shown in **Figure 11-4**. TL0 uses the Timer 0 control bits GATE0, TR0 and TF0, while TH0 is locked into a timer function (counting machine cycles) and takes over the use of TR1 and TF1 from Timer 1. Thus, TH0 now sets TF1 upon overflow and generates an interrupt if ET1 is set.

Mode 3 is provided for applications requiring an extra 8-bit timer. When Timer 0 is in mode 3 and TR1 is set, Timer 1 can be turned on by switching it to any of the other modes and turned off by switching it into mode 3.

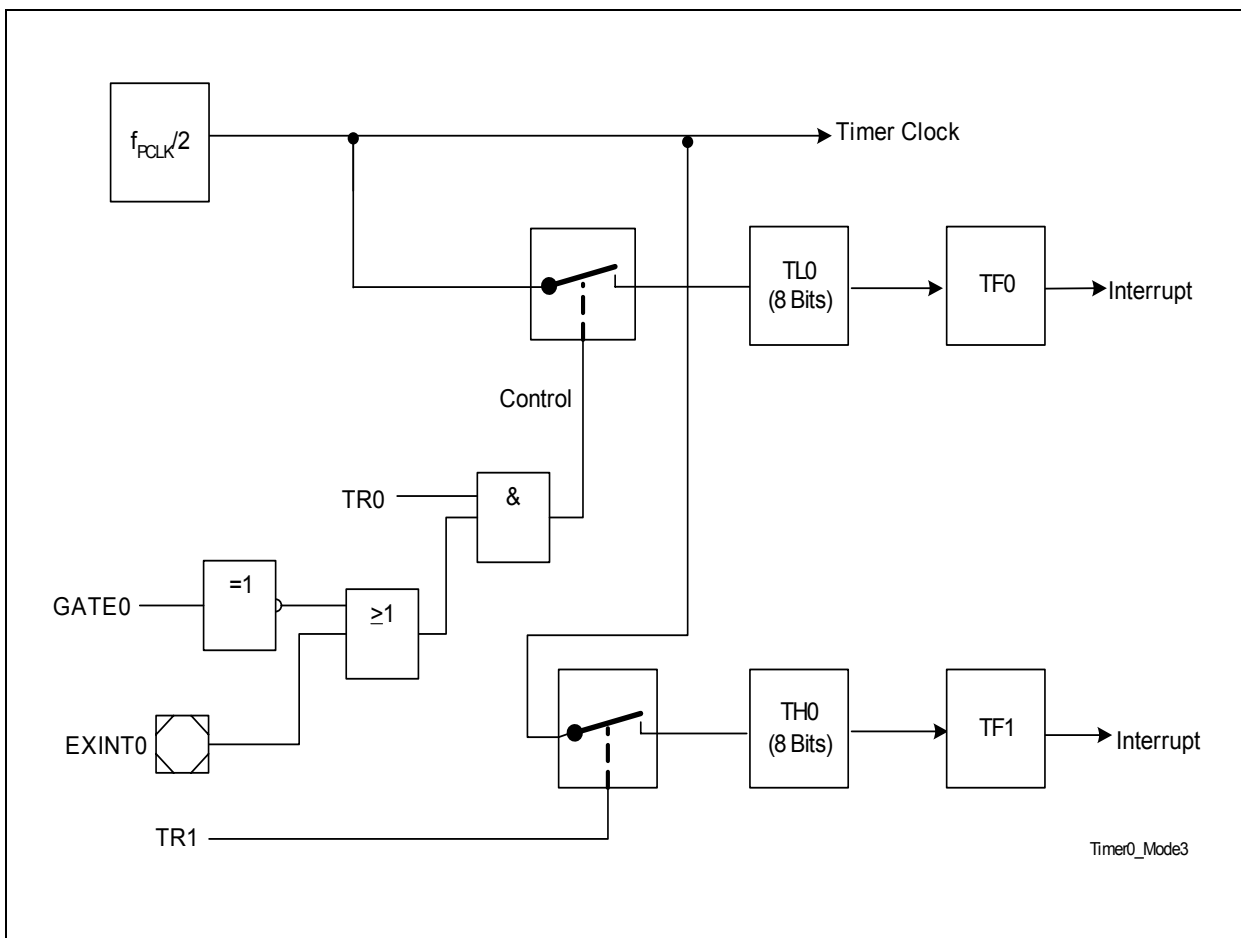

Figure 11-4 Timer 0, Mode 3: Two 8-bit Timers

11.1.3 Register Map

Seven SFRs control the operations of Timer 0 and Timer 1. They can be accessed from both the standard (non-mapped) and mapped SFR area. [Table 11-2](#) lists the addresses of these SFRs.

Table 11-2 SFR Address List

Address	Register
88 _H	TCON
89 _H	TMOD
8A _H	TL0
8B _H	TL1
8C _H	TH0
8D _H	TH1

11.1.4 Register Description

The low and high bytes of both Timer 0 and Timer 1 can be combined to a one-timer configuration depending on the mode used.

TLx (x = 0 - 1)

Timer x Register Low

Reset Value: 00_H

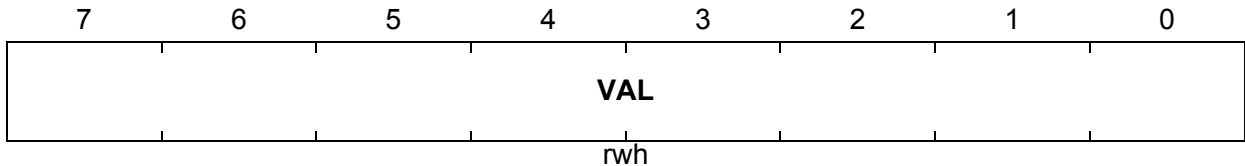

THx (x = 0 - 1)

Timer x Register High

Reset Value: 00_H

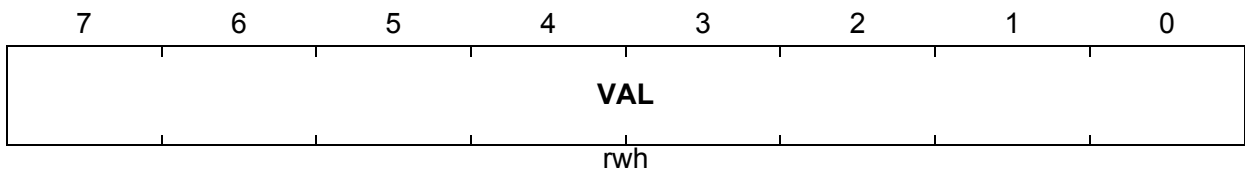

Field	Bits	Type	Description	
TLx.VAL (x = 0 - 1)	[7:0]	rwh	Timer 0/1 Low Register	
			Operating Mode	Description
			0	“TLx” holds the 5-bit prescaler value.
			1	“TLx” holds the lower 8-bit part of the 16-bit timer value.
			2	“TLx” holds the 8-bit timer value.
3	TL0 holds the 8-bit timer value; TL1 is not used.			

Field	Bits	Type	Description	
THx.VAL (x = 0 - 1)	[7:0]	rwh	Timer 0/1 High Register	
			Operating Mode	Description
			0	“THx” holds the 8-bit timer value.
			1	“THx” holds the higher 8-bit part of the 16-bit timer value.
			2	“THx” holds the 8-bit reload value.
3	TH0 holds the 8-bit timer value; TH1 is not used.			

Register TCON controls the operations of Timer 0 and Timer 1.

TCON

Timer Control Register

Reset Value: 00_H

7	6	5	4	3	2	1	0
TF1	TR1	TF0	TR0	IE1	IT1	IE0	IT0
rw	rw	rw	rw	rw	rw	rw	rw



The functions of the shaded bits are not described here

Field	Bits	Type	Description
TR0	4	rw	Timer 0 Run Control 0 Timer is halted 1 Timer runs
TF0	5	rw	Timer 0 Overflow Flag Set by hardware when Timer 0 overflows. Cleared by hardware when the processor calls the interrupt service routine.
TR1	6	rw	Timer 1 Run Control¹⁾ 0 Timer is halted 1 Timer runs
TF1	7	rw	Timer 1 Overflow Flag Set by hardware when Timer 1 ²⁾ overflows. Cleared by hardware when the processor calls the interrupt service routine.

1) Also affects TH0 if Timer 0 operates in mode 3.

2) TF1 is set by TH0 instead if Timer 0 operates in mode 3.

Register TMOD contains bits that select the operating modes of Timer 0 and Timer 1.

TMOD

Timer Mode Register

Reset Value: 00_H

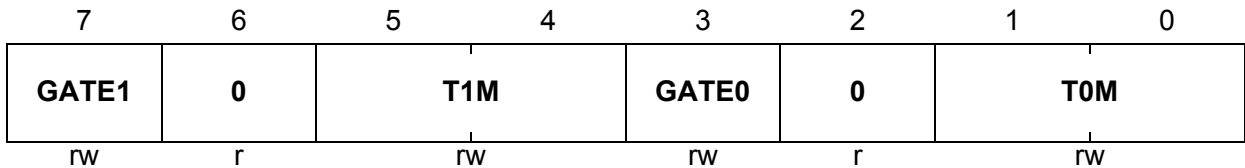

Field	Bits	Type	Description										
T0M[1:0] T1M[1:0]	[1:0] [5:4]	rw	<p>Mode select bits</p> <table border="1" style="width: 100%; border-collapse: collapse;"> <thead> <tr> <th style="text-align: left;">T0M/T1M [1:0]</th> <th style="text-align: left;">Function</th> </tr> </thead> <tbody> <tr> <td style="text-align: center;">00</td> <td>13-bit timer (M8048 compatible mode)</td> </tr> <tr> <td style="text-align: center;">01</td> <td>16-bit timer</td> </tr> <tr> <td style="text-align: center;">10</td> <td>8-bit auto-reload timer</td> </tr> <tr> <td style="text-align: center;">11</td> <td> <p>Timer 0: Timer 0 is divided into two parts. TL0 is an 8-bit timer controlled by the standard Timer 0 control bits, and TH0 is the other 8-bit timer controlled by the standard Timer 1 control bits.</p> <p>Timer 1: TL1 and TH1 are held (Timer 1 is stopped).</p> </td> </tr> </tbody> </table>	T0M/T1M [1:0]	Function	00	13-bit timer (M8048 compatible mode)	01	16-bit timer	10	8-bit auto-reload timer	11	<p>Timer 0: Timer 0 is divided into two parts. TL0 is an 8-bit timer controlled by the standard Timer 0 control bits, and TH0 is the other 8-bit timer controlled by the standard Timer 1 control bits.</p> <p>Timer 1: TL1 and TH1 are held (Timer 1 is stopped).</p>
T0M/T1M [1:0]	Function												
00	13-bit timer (M8048 compatible mode)												
01	16-bit timer												
10	8-bit auto-reload timer												
11	<p>Timer 0: Timer 0 is divided into two parts. TL0 is an 8-bit timer controlled by the standard Timer 0 control bits, and TH0 is the other 8-bit timer controlled by the standard Timer 1 control bits.</p> <p>Timer 1: TL1 and TH1 are held (Timer 1 is stopped).</p>												
GATE0	3	rw	<p>Timer 0 Gate Flag</p> <p>0 Timer 0 will only run if TCON.TR0 = 1 (software control).</p> <p>1 Timer 0 will only run if EXINT0 pin = 1 (hardware control) and TCON.TR0 is set.</p>										
GATE1	7	rw	<p>Timer 1 Gate Flag</p> <p>0 Timer 1 will only run if TCON.TR1 = 1 (software control).</p> <p>1 Timer 1 will only run if EXINT1 pin = 1 (hardware control) and TCON.TR1 is set.</p>										

Field	Bits	Type	Description
0	2, 6	r	Reserved Returns 0 if read; should be written with 0.

Register IEN0 contains bits that enable interrupt operations in Timer 0 and Timer 1.

IEN0

Interrupt Enable Register

Reset Value: 00_H

7	6	5	4	3	2	1	0
EA	0	ET2	ES	ET1	EX1	ET0	EX0
rw	r	rw	rw	rw	rw	rw	rw



The functions of the shaded bits are not described here

Field	Bits	Type	Description
ET0	1	rw	Timer 0 Overflow Interrupt Enable 0 Timer 0 interrupt is disabled. 1 Timer 0 interrupt is enabled.
ET1	3	rw	Timer 1 Overflow Interrupt Enable¹⁾ 0 Timer 1 interrupt is disabled. 1 Timer 1 interrupt is enabled.

¹⁾ When Timer 0 operates in mode 3, this interrupt indicates an overflow in the Timer 0 register, TH0.

11.2 Timer 2

Timer 2 is a 16-bit general purpose timer that has two modes of operation, a 16-bit auto-reload mode and a 16-bit one channel capture mode. If the prescaler is disabled, Timer 2 counts with an input clock of PCLK/12.

11.2.1 Auto-Reload Mode

The auto-reload mode is selected when the bit $\overline{CP/RL2}$ in register T2CON is zero. In this mode, Timer 2 counts to an overflow value and then reloads its register contents with a 16-bit start value for a fresh counting sequence. The overflow condition is indicated by setting bit TF2 in the T2CON register. This will then generate an interrupt request to the core. The overflow flag TF2 must be cleared by software.

The auto-reload mode is further classified into two categories depending upon the DCEN control bit in register T2MOD.

11.2.1.1 Up/Down Count Disabled

If DCEN = 0, the up-down count selection is disabled. The timer, therefore, functions as a pure up counting timer only. The operational block diagram is shown in [Figure 11-5](#).

If the T2CON register bit EXEN2 = 0, the timer starts to count up to a maximum of $FFFF_H$ once the timer is started by setting the bit TR2 in register T2CON to 1. Upon overflow, bit TF2 is set and the timer register is reloaded with the 16-bit reload value of the RC2 register. This reload value is chosen by software, prior to the occurrence of an overflow condition. A fresh count sequence is started and the timer counts up from this reload value as in the previous count sequence.

If EXEN2 = 1, the timer counts up to a maximum of $FFFF_H$ once TR2 is set. A 16-bit reload of the timer registers from register RC2 is triggered either by an overflow condition or by a negative/positive edge (chosen by the bit EDGESEL in register T2MOD) at input pin T2EX. If an overflow caused the reload, the overflow flag TF2 is set. If a negative/positive transition at pin T2EX caused the reload, bit EXF2 in register T2CON is set. In either case, an interrupt is generated to the core and the timer proceeds to its next count sequence. The EXF2 flag, similar to the TF2, must be cleared by software.

Note: When T2EX is used for the Timer 2 function, the bit BCON.T2EXIS must be set.

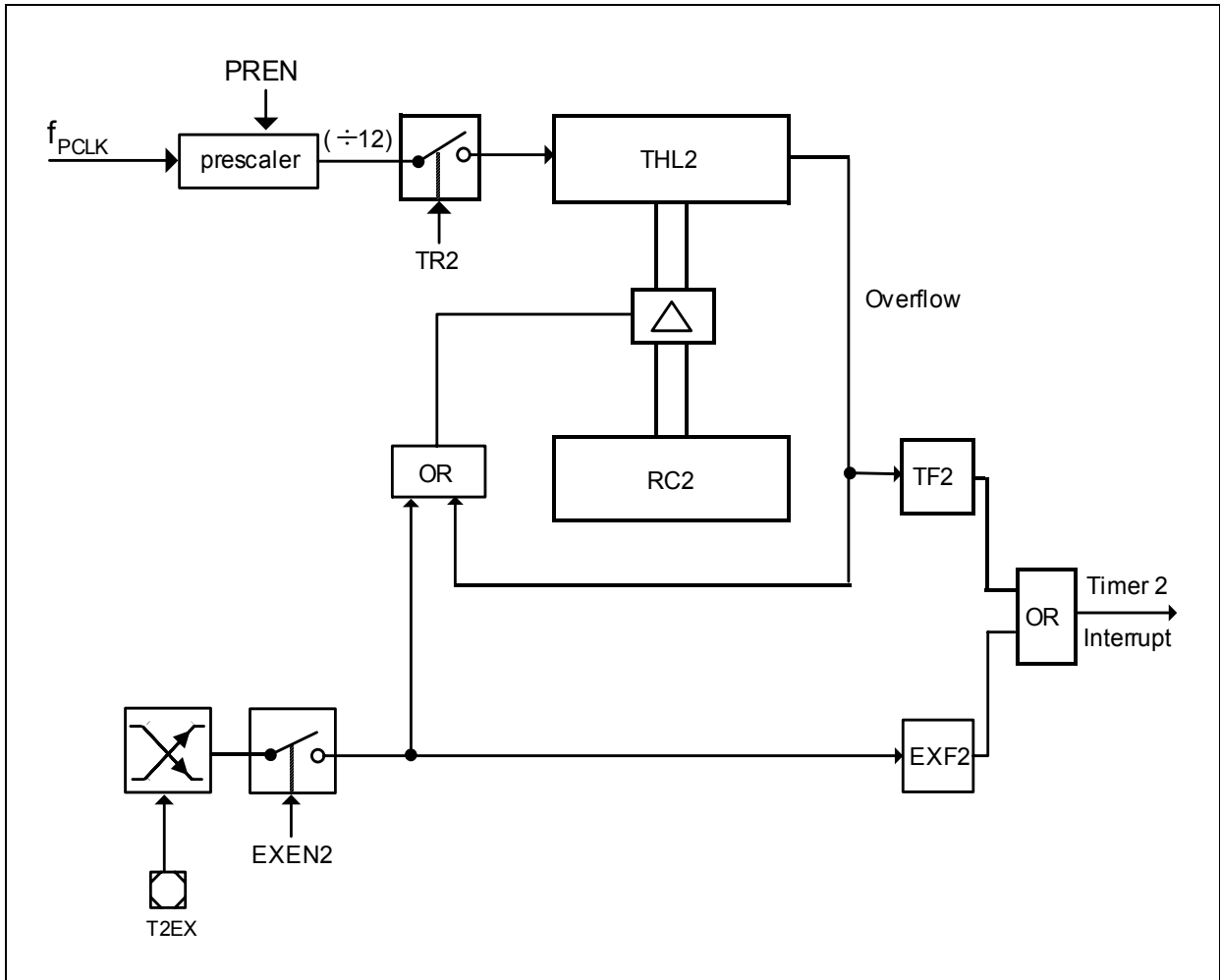

Figure 11-5 Auto-Reload Mode (DCEN = 0)

11.2.1.2 Up/Down Count Enabled

If DCEN = 1, the up-down count selection is enabled. The direction of count is determined by the level at input pin T2EX. The operational block diagram is shown in [Figure 11-6](#).

A logic 1 at pin T2EX sets the Timer 2 to up counting mode. The timer, therefore, counts up to a maximum of $FFFF_H$. Upon overflow, bit TF2 is set and the timer register is reloaded with a 16-bit reload value of the RC2 register. A fresh count sequence is started and the timer counts up from this reload value as in the previous count sequence. This reload value is chosen by software, prior to the occurrence of an overflow condition.

A logic 0 at pin T2EX sets the Timer 2 to down counting mode. The timer counts down and underflows when the THL2 value reaches the value stored at register RC2. The underflow condition sets the TF2 flag and causes $FFFF_H$ to be reloaded into the THL2

register. A fresh down counting sequence is started and the timer counts down as in the previous counting sequence.

In this mode, bit EXF2 toggles whenever an overflow or an underflow condition is detected. This flag, however, does not generate an interrupt request.

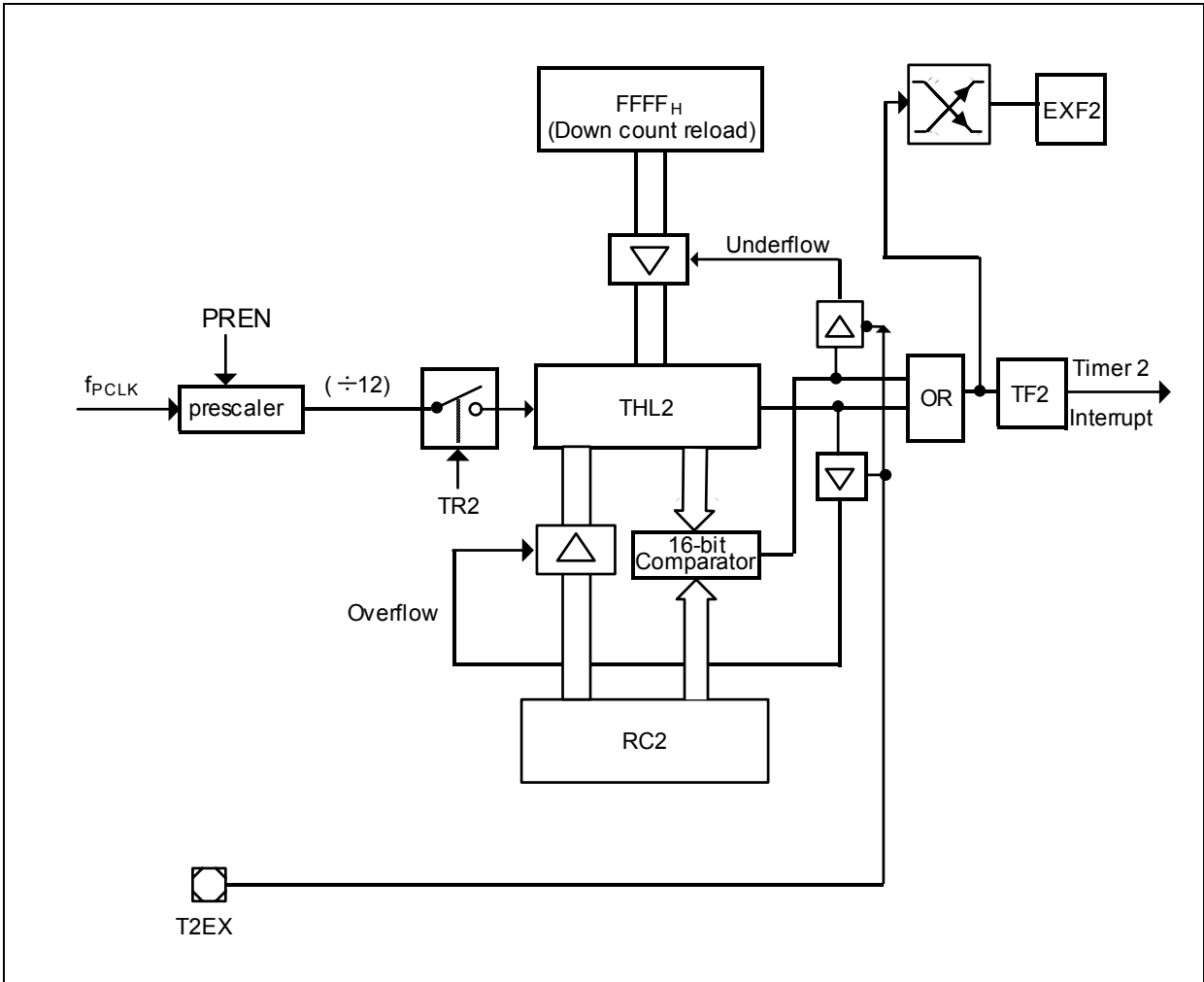

Figure 11-6 Auto-Reload Mode (DCEN = 1)

11.2.2 Capture Mode

In order to enter the 16-bit capture mode, bits $\overline{CP/RL2}$ and EXEN2 in register T2CON must be set. In this mode, the down count function must remain disabled. The timer functions as a 16-bit timer and always counts up to $FFFF_H$, after which, an overflow condition occurs. Upon overflow, bit TF2 is set and the timer reloads its registers with 0000_H . The setting of TF2 generates an interrupt request to the core.

Additionally, with a falling/rising edge (chosen by T2MOD.EDGESEL) on pin T2EX, the contents of the timer register (THL2) are captured into the RC2 register. If the capture signal is detected while the counter is being incremented, the counter is first incremented before the capture operation is performed. This ensures that the latest value of the timer register is always captured.

When the capture operation is completed, bit EXF2 is set and can be used to generate an interrupt request. **Figure 11-7** describes the capture function of Timer 2.

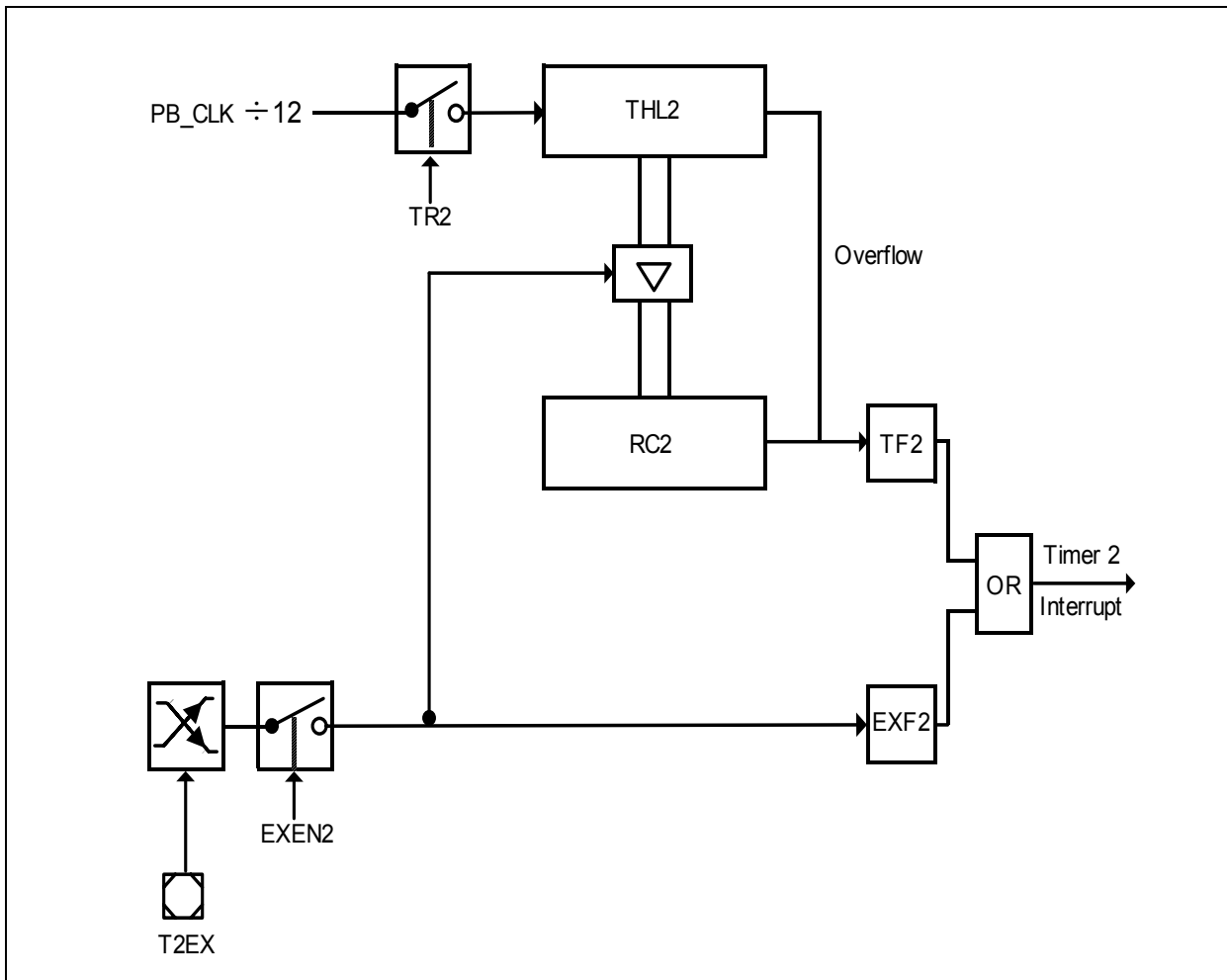

Figure 11-7 Capture Mode

11.2.3 Register Map

All Timer 2 register names described in the following sections will be referenced in other chapters of this document with the module name prefix “T2_”, e.g., T2_T2CON.

The Timer 2 SFRs are located in the standard (non-mapped) SFR area. **Table 11-3** lists the addresses of these SFRs.

Table 11-3 SFR Address List

Address	Register
C0 _H	T2CON
C1 _H	T2MOD
C2 _H	RC2L
C3 _H	RC2H
C4 _H	T2L
C5 _H	T2H

11.2.4 Register Description

Register T2MOD is used to configure Timer 2 for the various modes of operation.

T2MOD

Timer 2 Mode Register

Reset Value: 00_H

7	6	5	4	3	2	1	0
0	EDGESEL	PREN	T2PRE			DCEN	
r	rw	rw	rw			rw	

Field	Bits	Type	Description
DCEN	0	rw	Up/Down Counter Enable 0 Up/Down Counter function is disabled. 1 Up/Down Counter function is enabled and controlled by pin T2EX (Up = 1, Down = 0).

Field	Bits	Type	Description
T2PRE	[3:1]	rw	Timer 2 Prescaler Bit Selects the input clock for Timer 2 which is derived from the peripheral clock. 000 $f_{T2} = f_{PCLK}$ 001 $f_{T2} = f_{PCLK}/2$ 010 $f_{T2} = f_{PCLK}/4$ 011 $f_{T2} = f_{PCLK}/8$ 100 $f_{T2} = f_{PCLK}/16$ Others: reserved
PREN	4	rw	Prescaler Enable 0 Prescaler is disabled and the 2/12 divider takes effect. 1 Prescaler is enabled (see T2PRE bit) and the 2/12 divider is bypassed.
EDGESEL	5	rw	Edge Select in Capture Mode/Reload Mode 0 The falling edge at pin T2EX is selected. 1 The rising edge at pin T2EX is selected.
0	[7:6]	r	Reserved Returns 0 if read; should be written with 0.

Register T2CON controls the operating modes of Timer 2. In addition, it contains the status flags for interrupt generation.

T2CON
Timer 2 Control Register
Reset Value: 00_H

7	6	5	4	3	2	1	0
TF2	EXF2	0		EXEN2	TR2	0	CP/RL2
rwh	rwh	r		rw	rwh	r	rw

Field	Bits	Type	Description
CP/RL2	0	rw	Capture/Reload Select 0 Reload upon overflow or upon negative/positive transition at pin T2EX (when EXEN2 = 1). 1 Capture Timer 2 data register contents on the negative/positive transition at pin T2EX, provided EXEN2 = 1. The negative or positive transition at pin T2EX is selected by bit EDGESEL.
TR2	2	rwh	Timer 2 Start/Stop Control 0 Stop Timer 2 1 Start Timer 2
EXEN2	3	rw	Timer 2 External Enable Control 0 External events are disabled. 1 External events are enabled in capture/reload mode.
EXF2	6	rwh	Timer 2 External Flag In capture/reload mode, this bit is set by hardware when a negative/positive transition occurs at pin T2EX, if bit EXEN2 = 1. An interrupt request to the core is generated, unless bit DCEN = 1. This bit must be cleared by software.
TF2	7	rwh	Timer 2 Overflow/Underflow Flag Set by a Timer 2 overflow/underflow. Must be cleared by software.
0	1, [5:4]	r	Reserved Returns 0 if read; should be written with 0.

Register RC2 is used for a 16-bit reload of the timer count upon overflow or a capture of current timer count depending on the mode selected.

RC2L

Timer 2 Reload/Capture Register Low

Reset Value: 00_H

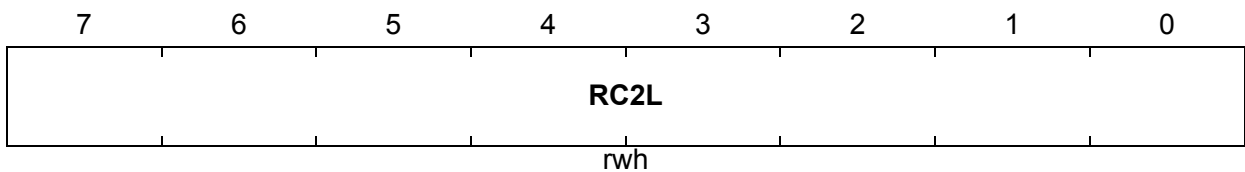

RC2H

Timer 2 Reload/Capture Register High

Reset Value: 00_H

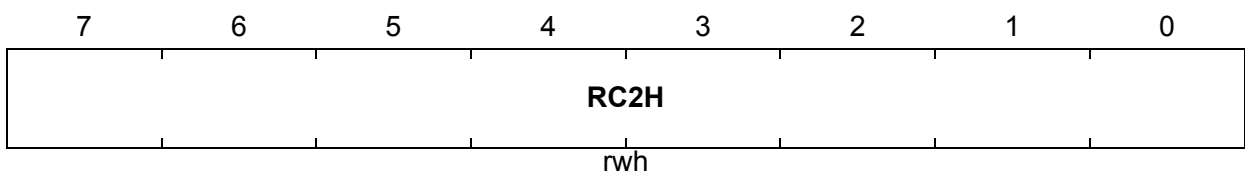

Field	Bits	Type	Description
RC2	[7:0] of RC2L, [7:0] of RC2H	rwh	Reload/Capture Value If CP/RL2 = 0, these contents are loaded into the timer register upon an overflow condition. If CP/RL2 = 1, this register is loaded with the current timer count upon a negative/positive transition at pin T2EX when EXEN2 = 1.

Register T2 holds the current 16-bit value of the Timer 2 count.

T2L

Timer 2 Register Low

Reset Value: 00_H

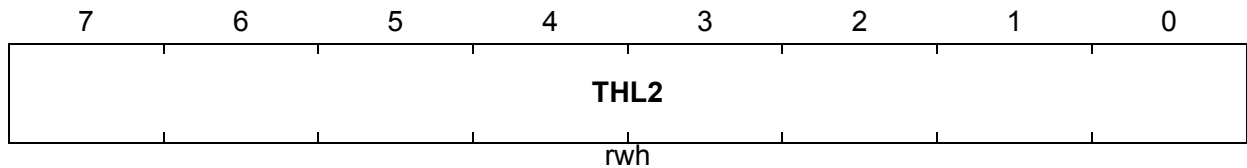

T2H

Timer 2 Register High

Reset Value: 00_H

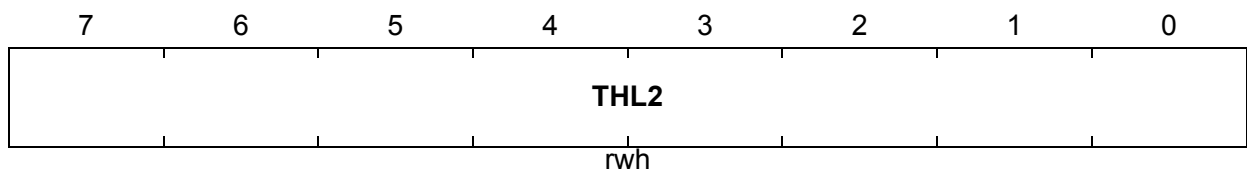

Field	Bits	Type	Description
THL2	[7:0] of T2L, [7:0] of T2H	rwh	Timer 2 Value These bits indicate the current timer value.

12 Capture/Compare Unit 6

The Capture/Compare Unit 6 (CCU6) provides two independent timers (T12, T13), which can be used for Pulse Width Modulation (PWM) generation, especially for AC-motor control. The CCU6 also supports special control modes for block commutation and multi-phase machines. The block diagram of the CCU6 module is shown in [Figure 12-1](#).

The timer T12 can function in capture and/or compare mode for its three channels. The timer T13 can work in compare mode only.

The multi-channel control unit generates output patterns, which can be modulated by T12 and/or T13. The modulation sources can be selected and combined for the signal modulation.

Timer T12 Features:

- Three capture/compare channels, each channel can be used either as a capture or as a compare channel
- Supports generation of a three-phase PWM (six outputs, individual signals for highside and lowside switches)
- 16-bit resolution, maximum count frequency = peripheral clock frequency
- Dead-time control for each channel to avoid short-circuits in the power stage
- Concurrent update of the required T12/13 registers
- Generation of center-aligned and edge-aligned PWM
- Supports single-shot mode
- Supports many interrupt request sources
- Hysteresis-like control mode

Timer T13 Features:

- One independent compare channel with one output
- 16-bit resolution, maximum count frequency = peripheral clock frequency
- Can be synchronized to T12
- Interrupt generation at period-match and compare-match
- Supports single-shot mode

Additional Features:

- Implements block commutation for Brushless DC-drives
- Position detection via Hall-sensor pattern
- Automatic rotational speed measurement for block commutation
- Integrated error handling
- Fast emergency stop without CPU load via external signal ($\overline{\text{CTRAP}}$)
- Control modes for multi-channel AC-drives
- Output levels can be selected and adapted to the power stage

Capture/Compare Unit 6

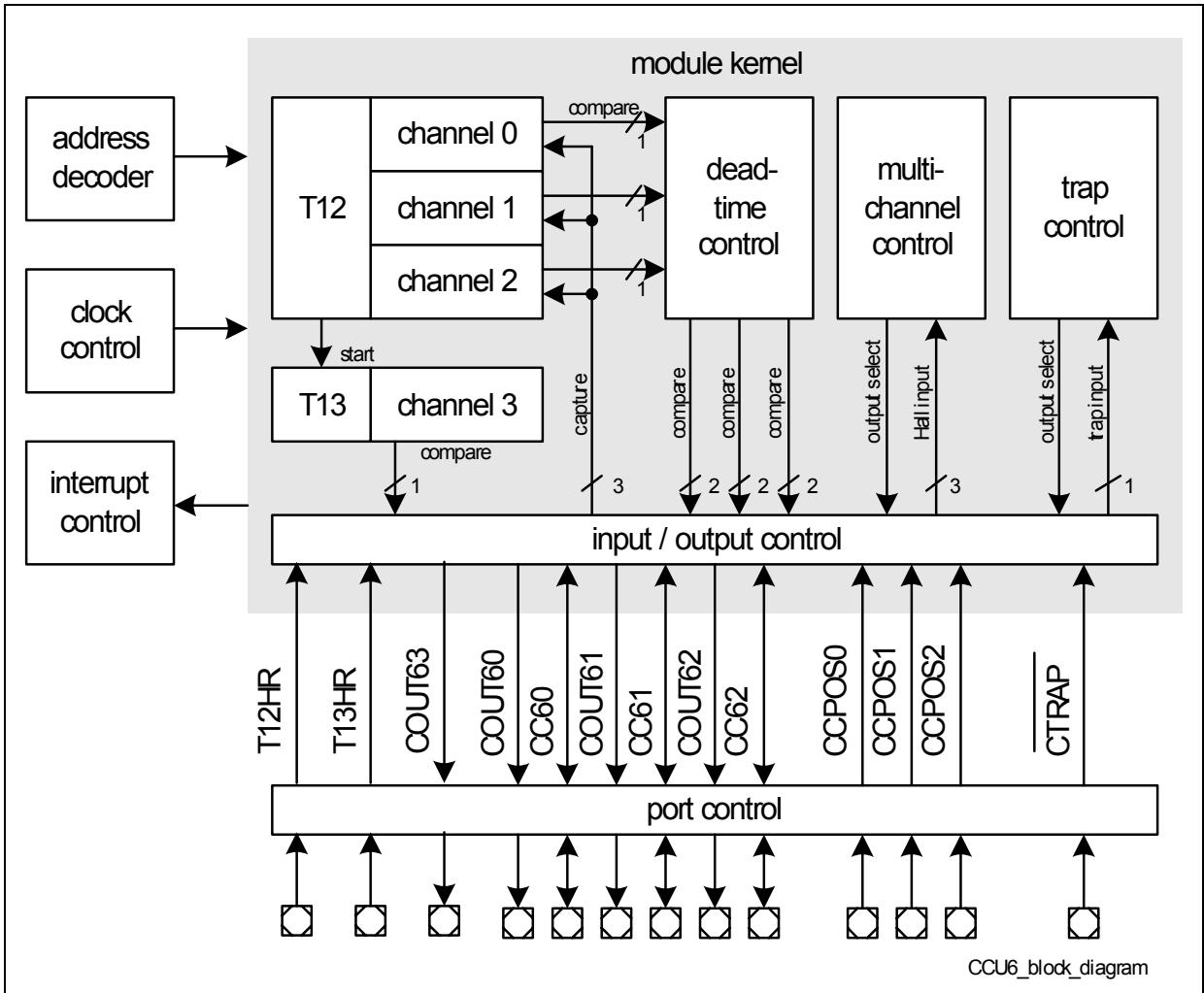

Figure 12-1 CCU6 Block Diagram

12.1 Functional Description

12.1.1 Timer T12

The timer T12 is built with three channels in capture/compare mode. The input clock for timer T12 can be from f_{CCU6} to a maximum of $f_{CCU6}/128$ and is configured by bit field T12CLK. In order to support higher clock frequencies, an additional prescaler factor of 1/256 can be enabled for the prescaler of T12 if bit T12PRE = 1.

The timer period, compare values, passive state selects bits and passive levels bits are written to shadow registers and not directly to the actual registers, while the read access targets the registers actually used (except for the three compare channels, where both the actual and the shadow registers can be read). The transfer from the shadow registers to the actual registers is enabled by setting the shadow transfer enable bit STE12.

If this transfer is enabled, the shadow registers are copied to the respective registers as soon as the associated timer reaches the value zero the next time (being cleared in edge-aligned mode or counting down to 1 in center-aligned mode). When timer T12 is operating in center-aligned mode, it will also copy the registers (if enabled by STE12) if it reaches the currently programmed period value (counting up).

When timer T12 is stopped, the shadow transfer takes place immediately if the corresponding bit STE12 is set. Once the transfer is complete, the respective bit STE12 is cleared automatically.

Figure 12-2 shows an overview of Timer T12.

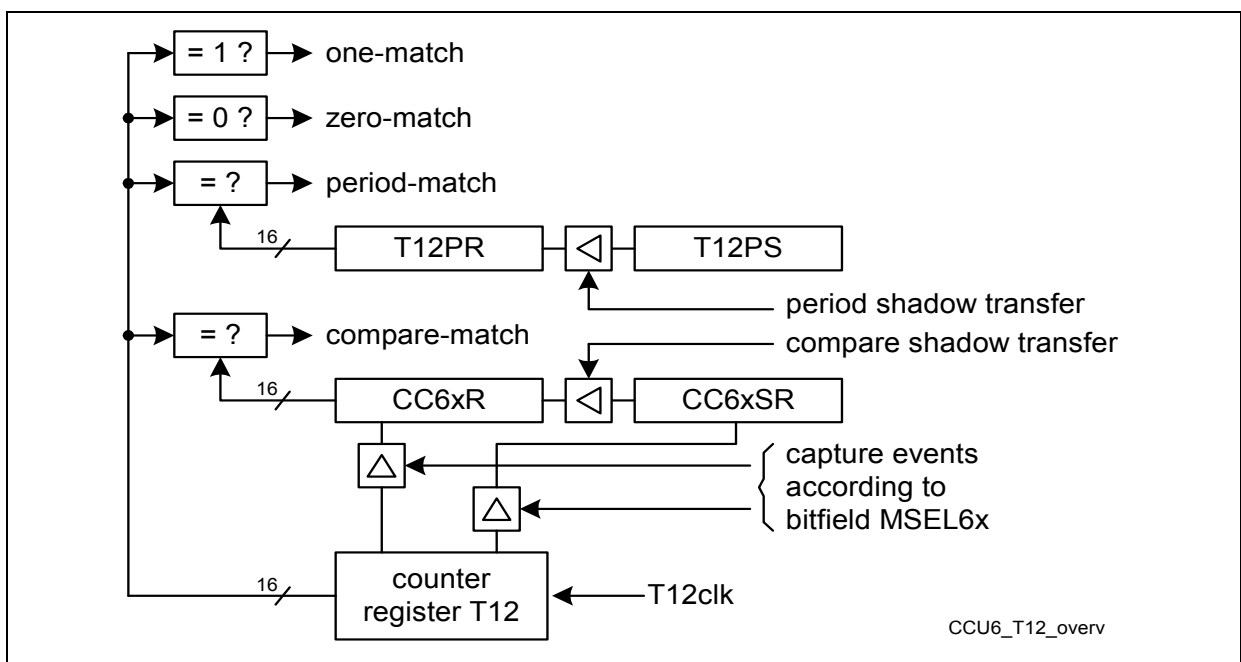

Figure 12-2 T12 Overview

12.1.1.1 Timer Configuration

Register T12 represents the counting value of timer T12. It can be written only while timer T12 is stopped. Write actions while T12 is running are not taken into account. Register T12 can always be read by software.

In edge-aligned mode, T12 only counts up, whereas in center-aligned mode, T12 can count up and down.

Timer T12 can be started and stopped by using bit T12R by hardware or software.

- Bit field T12RSEL defines the event on pin T12HR: rising edge, falling edge, or either of these two edges, that can set the run bit T12R by hardware.
- If bit field T12RSEL = 00_B, the external setting of T12R is disabled and the timer run bit can only be controlled by software. Bit T12R is set/reset by software by setting bit T12RR or T12RS.
- In single-shot mode, bit T12R is reset by hardware according to the function defined by bit T12SSC. If bit T12SSC = 1, the bit T12R is reset by hardware when:
 - T12 reaches its period value in edge-aligned mode
 - T12 reaches the value 1 while counting down in center-aligned mode

Register T12 can be reset to zero by setting bit T12RES. Setting of T12RES has no impact on run bit T12R.

12.1.1.2 Counting Rules

With reference to the T12 input clock, the counting sequence is defined by the following counting rules:

T12 in edge-aligned mode (Bit CTM = 0):

The count direction is set to counting up (CDIR = 0). The counter is reset to zero if a period-match is detected, and the T12 shadow register transfer takes place if STE12 = 1.

T12 in center-aligned mode (Bit CTM = 1):

- The count direction is set to counting up (CDIR = 0) if a one-match is detected while counting down.
- The count direction is set to counting down (CDIR = 1) if a period-match is detected while counting up.
- If STE12 = 1, shadow transfer takes place when:
 - a period-match is detected while counting up
 - a one-match is detected while counting down

The timer T12 prescaler is reset when T12 is not running to ensure reproducible timings and delays.

12.1.1.3 Switching Rules

Compare actions take place in parallel for the three compare channels. Depending on the count direction, the compare matches have different meanings. In order to get the

Capture/Compare Unit 6

PWM information independent of the output levels, two different states have been introduced for the compare actions: the active state and the passive state. Both these states are used to generate the desired PWM as a combination of the control by T13, the trap control unit and the multi-channel control unit. If the active state is interpreted as a 1 and the passive state as a 0, the state information is combined with a logical AND function.

- active AND active = active
- active AND passive = passive
- passive AND passive = passive

The compare states change with the detected compare-matches and are indicated by the CC6xST bits. The compare states of T12 are defined as follows:

- passive if the counter value is below the compare value
- active if the counter value is above the compare value

This leads to the following switching rules for the compare states:

- set to the active state when the counter value reaches the compare value while counting up
- reset to the passive state when the counter value reaches the compare value while counting down
- reset to the passive state in case of a zero-match without compare-match while counting up
- set to the active state in case of a zero-match with a parallel compare-match while counting up

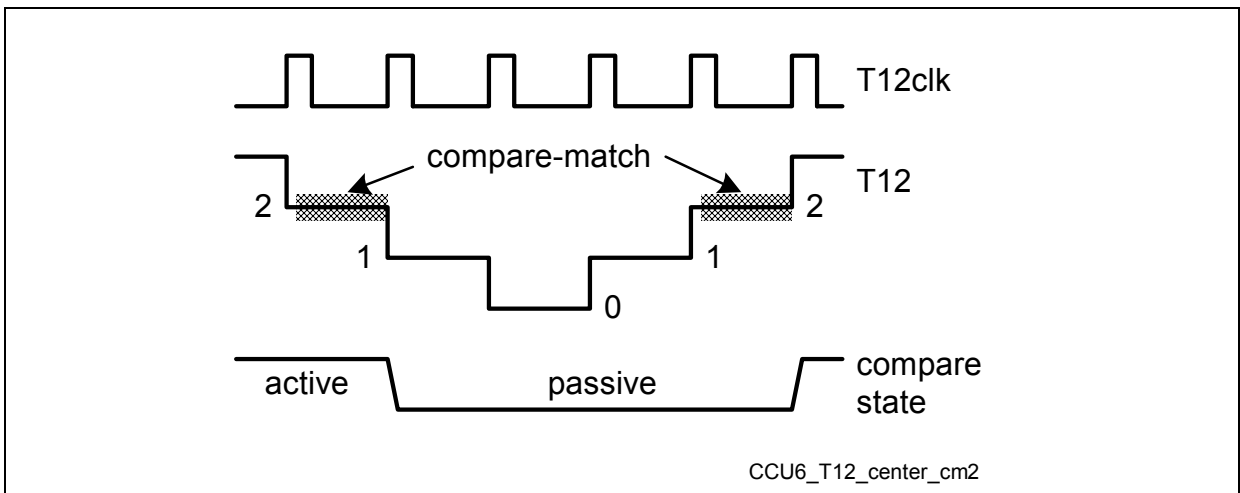

Figure 12-3 Compared States for Compare Value = 2

The switching rules are considered only while the timer is running. As a result, write actions to the timer registers while the timer is stopped do not lead to compare actions.

12.1.1.4 Compare Mode of T12

In compare mode, the registers CC6xR ($x = 0 - 2$) are the actual compare registers for T12. The values stored in CC6xR are compared (all three channels in parallel) to the counter value of T12. The register CC6xR can only be read by software and the modification of the value is done by a shadow register transfer from register CC6xSR.

Register T12PR contains the period value for timer T12. The period value is compared to the actual counter value of T12 and the resulting counter actions depend on the defined counting rules.

Figure 12-4 shows an example in the center-aligned mode without dead-time. The bit CC6xST indicates the occurrence of a capture or compare event of the corresponding channel. It can be set (if it is 0) by the following events:

- a software set (MCC6xS)
- a compare set event (T12 counter value above the compare value) if the T12 runs and if the T12 set event is enabled
- upon a capture set event

The bit CC6xST can be reset (if it is 1) by the following events:

- a software reset (MCC6xR)
- a compare reset event (T12 counter value below the compare value) if the T12 runs and if the T12 reset event is enabled (including in single-shot mode at the end of the T12 period)
- a reset event in the hysteresis-like control mode

The bit CC6xPS represents passive state select bit. The timer T12's two output lines (CC6x, COU6x) can be selected to be in the passive state while CC6xST is 0 (with CC6xPS = 0) or while CC6xST is 1 (with CC6xPS = 1).

The output level that is driven while the output is in the passive state is defined by the corresponding bit in bit field PSL.

Hardware modifications of the compare state bits are only possible while timer T12 is running. Therefore, the bit T12R can be used to enable/disable the modification by hardware.

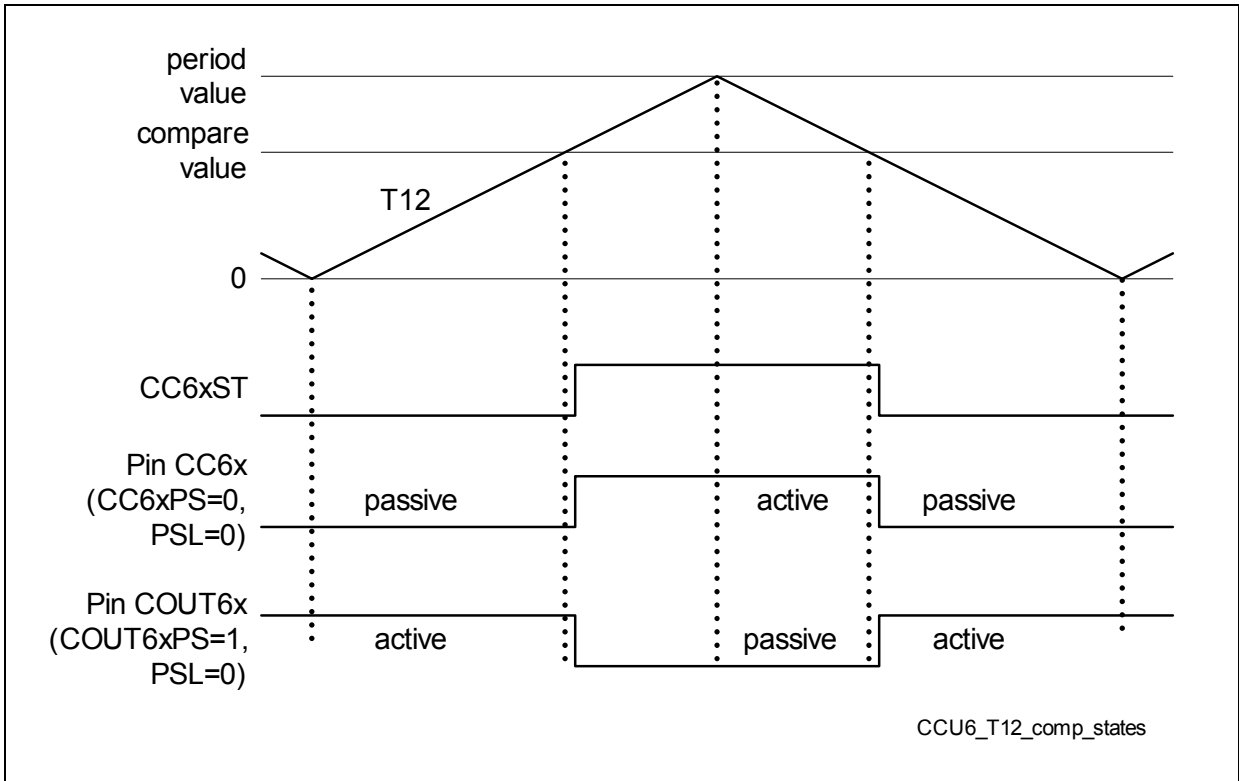

Figure 12-4 Compare States of Timer T12

For the hysteresis-like compare mode ($MSEL6x = 1001_B$) (see [Section 12.1.1.9](#)), the setting of the compare state bit is possible only while the corresponding input $CCPOSx = 1$ (inactive).

If the hall sensor mode ($MSEL6x = 1000_B$) is selected (see [Section 12.1.6](#)), the compare state bits of the compare channels 1 and 2 are modified by the timer T12 in order to indicate that a programmed time interval has elapsed.

The set is only generated when bit CC6xST is reset; a reset can only take place when the bit is set. Thus, the events triggering the set and reset actions of the CC6xST bit must be combined. This OR-combination of the resulting set and reset permits the reload of the dead-time counter to be triggered (see [Figure 12-5](#)). This is triggered only if bit CC6xST is changed, permitting a correct PWM generation with dead-time and the complete duty cycle range of 0% to 100% in edge-aligned and center-aligned modes.

12.1.1.5 Duty Cycle of 0% and 100%

These counting and switching rules ensure a PWM functionality in the full range between 0% and 100% duty cycle (duty cycle = active time/total PWM period). In order to obtain a duty cycle of 0% (compare state never active), a compare value of $T12P+1$ must be programmed (for both compare modes). A compare value of 0 will lead to a duty cycle of 100% (compare state always active).

12.1.1.6 Dead-time Generation

In most cases, the switching behavior of the connected power switches is not symmetrical with respect to the times needed to switch on and to switch off. A general problem arises if the time taken to switch on is less than the time to switch off the power device. This leads to a short-circuit in the inverter bridge leg, which may damage the entire system. In order to solve this problem by hardware, the CCU6 contains a programmable dead-time counter, which delays the passive to active edge of the switching signals (the active to passive edge is not delayed).

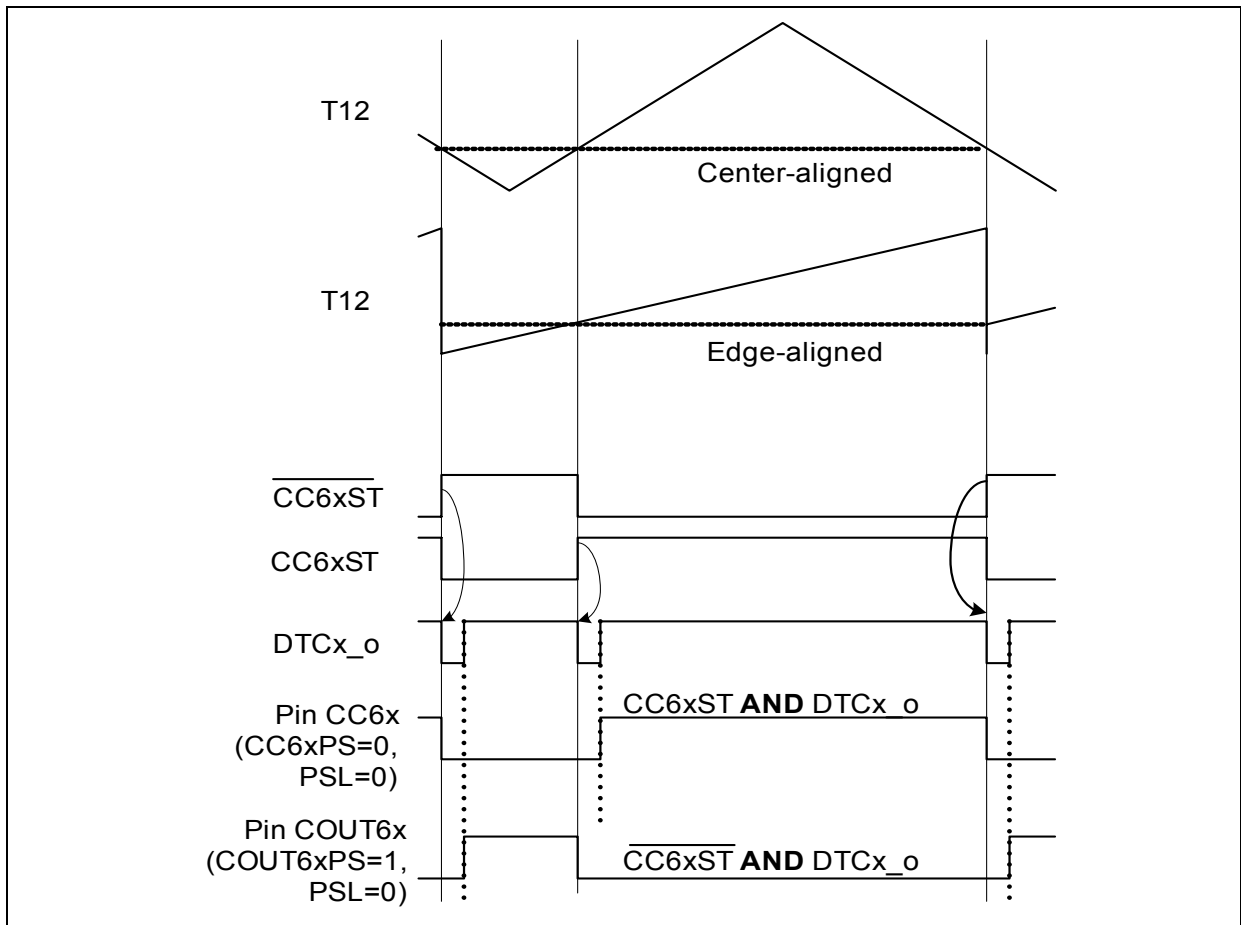

Figure 12-5 PWM-signals with Dead-time Generation

Register T12DTC controls the dead-time generation for the timer T12 compare channels. Each channel can be independently enabled/disabled for dead-time generation by bit DTE_x. If enabled, the transition from passive state to active state is delayed by the value defined by bit field DTM (8-bit down counter, clocked with T12CLK). The dead-time counter can only be reloaded when it is zero.

Each of the three channels works independently with its own dead-time counter, trigger and enable signals. The value of bit field DTM is valid for all three channels.

12.1.1.7 Capture Mode

In capture mode, the bits CC6xST indicate the occurrence of the selected capture event according to the bit fields MSEL6x.

- MSEL6x = 01XX_B, double register capture mode (see [Table 12-5](#))
- MSEL6x = 101X_B or 11XX_B, multi-input capture modes (see [Table 12-7](#))

A rising and/or a falling edge on the pins CC6x or CCPOSx can be selected as the capture event that is used to transfer the contents of timer T12 to the CC6xR and CC6xSR registers. In order to work in capture mode, the capture pins must be configured as inputs.

There are several ways to store the captured values in the registers. For example, in double register capture mode, the timer value is stored in the channel shadow register CC6xSR. The value previously stored in this register is simultaneously copied to the channel register CC6xR. The software can then check the newly captured value while still preserving the possibility of reading the value captured earlier.

Note: In capture mode, a shadow transfer can be requested according to the shadow transfer rules, except for the capture/compare registers that are left unchanged.

12.1.1.8 Single-Shot Mode

The single-shot mode of timer T12 is selected when bit T12SSC is set to 1. In single-shot mode, the timer T12 stops automatically at the end of its counting period. [Figure 12-6](#) shows the functionality at the end of the timer period in edge-aligned and center-aligned modes. If the end of period event is detected while bit T12SSC is set, the bit T12R and all CC6xST bits are reset.

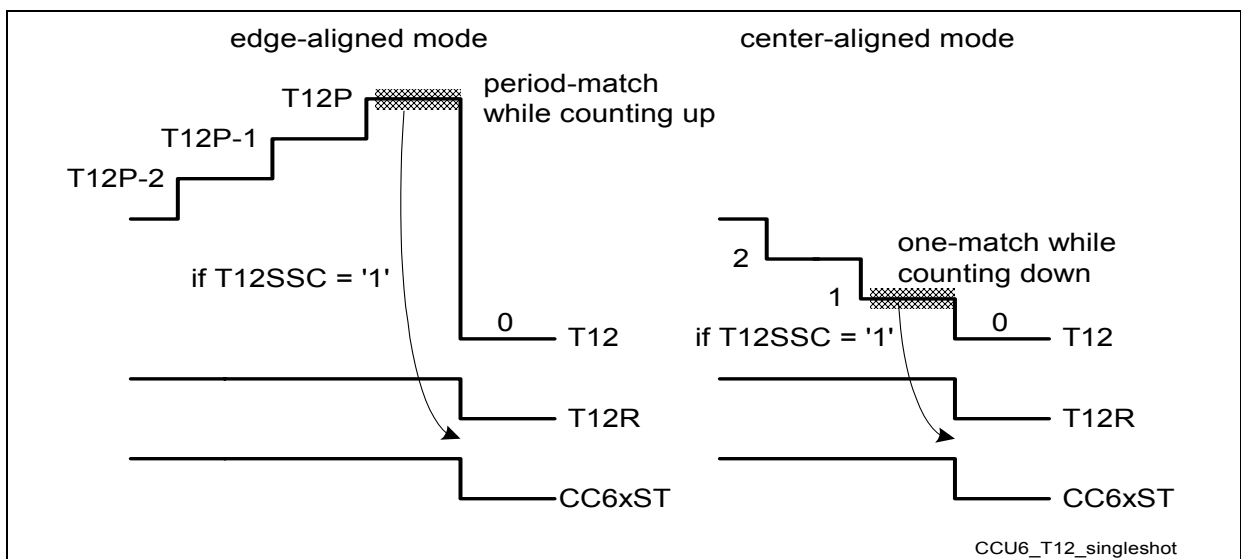

Figure 12-6 End of Single-Shot Mode of T12

12.1.1.9 Hysteresis-Like Control Mode

The hysteresis-like control mode ($MSEL6x = 1001_B$) offers the possibility of switching off the PWM output, if the input $CCPOSx$ becomes 0, by resetting bit $CC6xST$. This can be used as a simple motor control feature by using a comparator to indicate, for example, over-current. While $CCPOSx = 0$, the PWM outputs of the corresponding channel are driving their passive levels. The setting of bit $CC6xST$ is only possible while $CCPOSx = 1$. **Figure 12-7** shows an example of hysteresis-like control mode.

This mode can be used to introduce a timing-related behavior to a hysteresis controller. A standard hysteresis controller detects if a value exceeds a limit and switches its output according to the compare result. Depending on the operating conditions, the switching frequency and the duty cycle may change constantly.

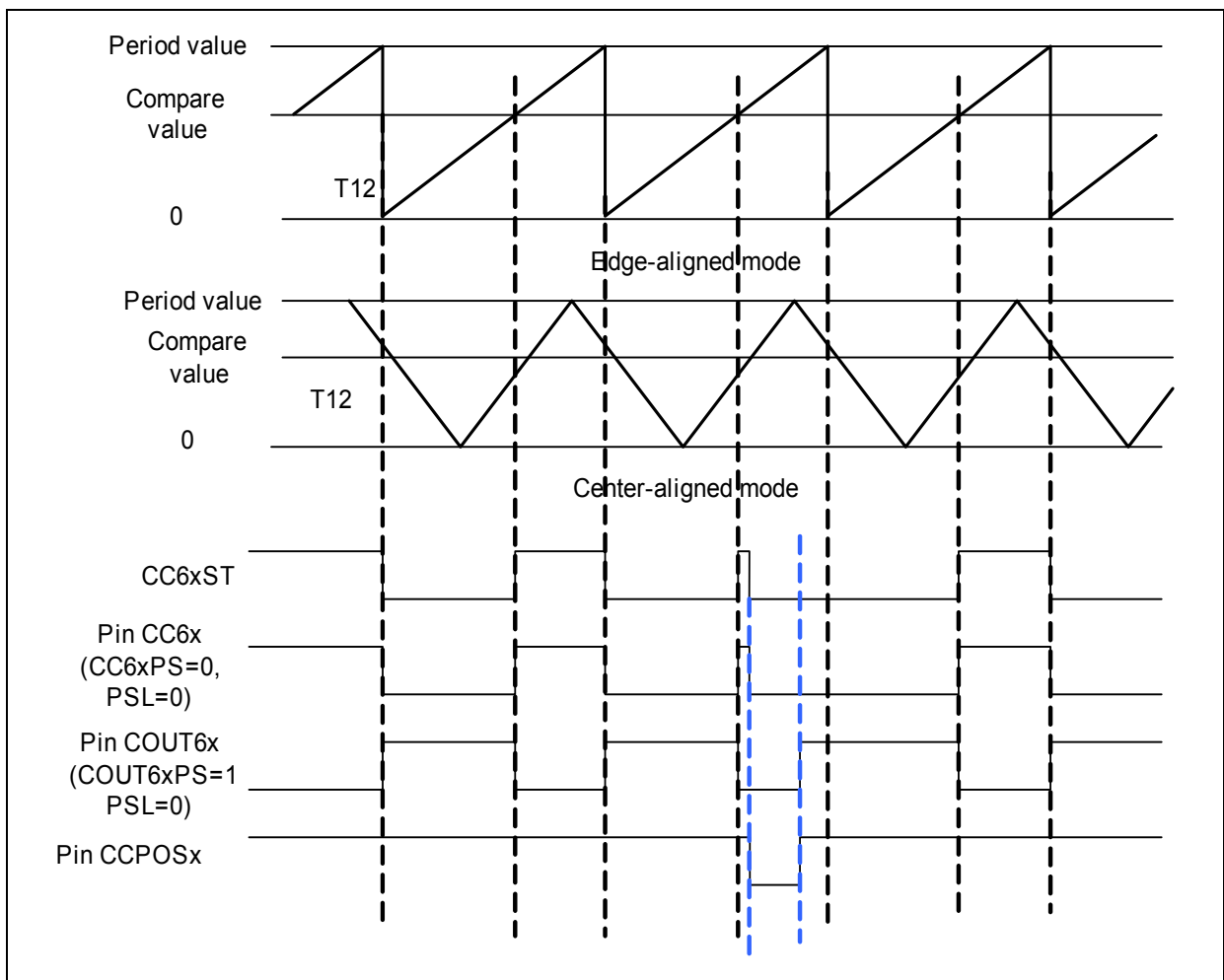

Figure 12-7 Hysteresis-Like Control Mode

12.1.2 Timer T13

The timer T13 is similar to timer T12, except that it has only one channel in compare mode. The counter can only count up (similar to the edge-aligned mode of T12). The input clock for timer T13 can be from f_{CCU6} to a maximum of $f_{CCU6}/128$ and is configured by bit field T13CLK. In order to support higher clock frequencies, an additional prescaler factor of $1/256$ can be enabled for the prescaler of T13 if bit T13PRE = 1.

The T13 shadow transfer, in case of a period-match, is enabled by bit STE13. During the T13 shadow transfer, the contents of register CC63SR are transferred to register CC63R. Both registers can be read by software, while only the shadow register can be written by software.

The bits CC63PS, T13IM and PSL63 have shadow bits. The contents of these shadow bits are transferred to the actually used bits during the T13 shadow transfer. Write actions target the shadow bits, while read actions deliver the value of the actually used bits.

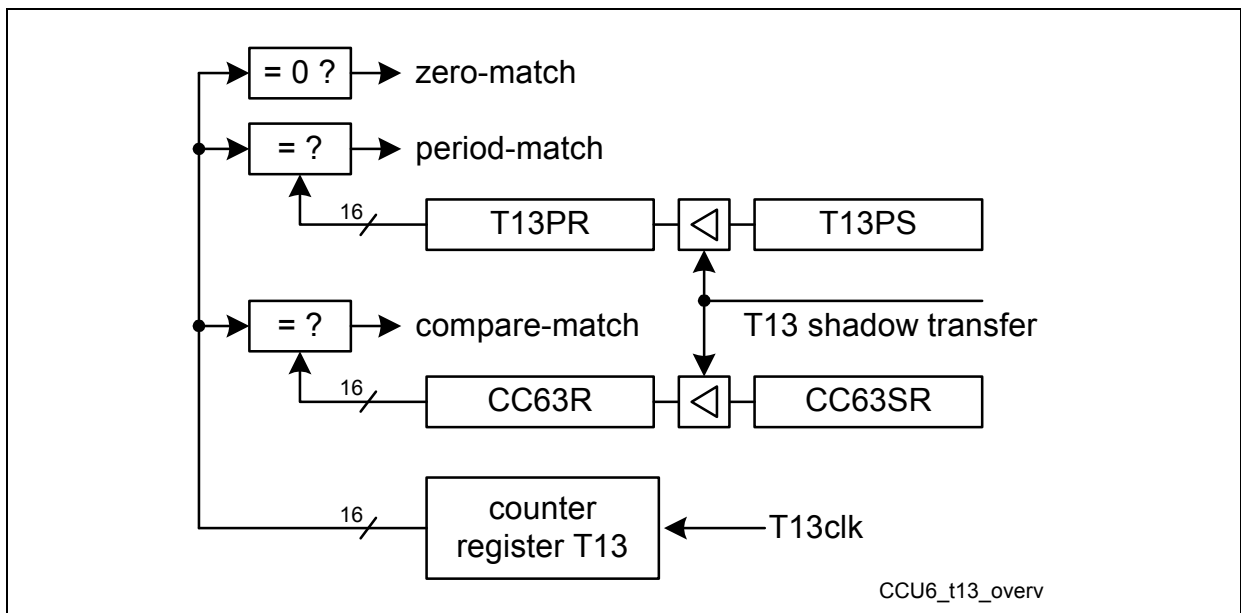

Figure 12-8 T13 Overview

Timer T13 counts according to the same counting and switching rules as timer T12 in edge-aligned mode. Figure 12-8 shows an overview of Timer T13.

12.1.2.1 Timer Configuration

Register T13 represents the counting value of timer T13. It can be written only while the timer T13 is stopped. Write actions are not taken into account while T13 is running. Register T13 can always be read by software. Timer T13 supports only edge-aligned mode (counting up).

Timer T13 can be started and stopped by using bit T13R by hardware or software.

- Bit T13R is set/reset by software by setting bit T13RR or T13RS.
- In single-shot mode, if bit T13SSC = 1, the bit T13R is reset by hardware when T13 reaches its period value.
- Bit fields T13TEC and T13TED select the trigger event that will set bit T13R for synchronization of different T12 compare events.

The T13 counter register can be reset to zero by setting bit T13RES. Setting of T13RES has no impact on bit T13R.

12.1.2.2 Compare Mode

Register CC63R is the actual compare register for T13. The value stored in CC63R is compared to the counter value of T13. The register CC63R can only be read by software and the modification of the value is done by a shadow register transfer from register CC63SR. The corresponding shadow register CC63SR can be read and written by software.

Register T13PR contains the period value for timer T13. The period value is compared to the actual counter value of T13 and the resulting counter actions depend on the defined counting rules.

The bit CC63ST indicates the occurrence of a compare event of the corresponding channel. It can be set (if it is 0) by the following events:

- a software set (MCC63S)
- a compare set event (T13 counter value above the compare value) if the T13 runs and if the T13 set event is enabled

The bit CC63ST can be reset (if it is 1) by the following events:

- a software reset (MCC63R)
- a compare reset event (T13 counter value below the compare value) if the T13 runs and if the T13 reset event is enabled (including in single-shot mode at the end of the T13 period)

Timer T13 is used to modulate the other output signals with a T13 PWM. In order to decouple COUT63 from the internal modulation, the compare state can be selected independently by bits T13IM and COUT63PS.

12.1.2.3 Single-Shot Mode

The single-shot mode of timer T13 is selected when bit T13SSC is set to 1. In single-shot mode, the timer T13 stops automatically at the end of its counting period. If the end of period event is detected while bit T13SSC is set, the bit T13R and the bit CC63ST are reset.

12.1.2.4 Synchronization of T13 to T12

The timer T13 can be synchronized on a T12 event. The events include:

- a T12 compare event on channel 0
- a T12 compare event on channel 1
- a T12 compare event on channel 2
- any T12 compare event on channel 0, 1, or 2
- a period-match of T12
- a zero-match of T12 (while counting up)
- any edge of inputs CCPOSx

The bit fields T13TEC and T13TED select the event that is used to start timer T13. This event sets bit T13R by hardware and T13 starts counting. Combined with the single-shot mode, this can be used to generate a programmable delay after a T12 event.

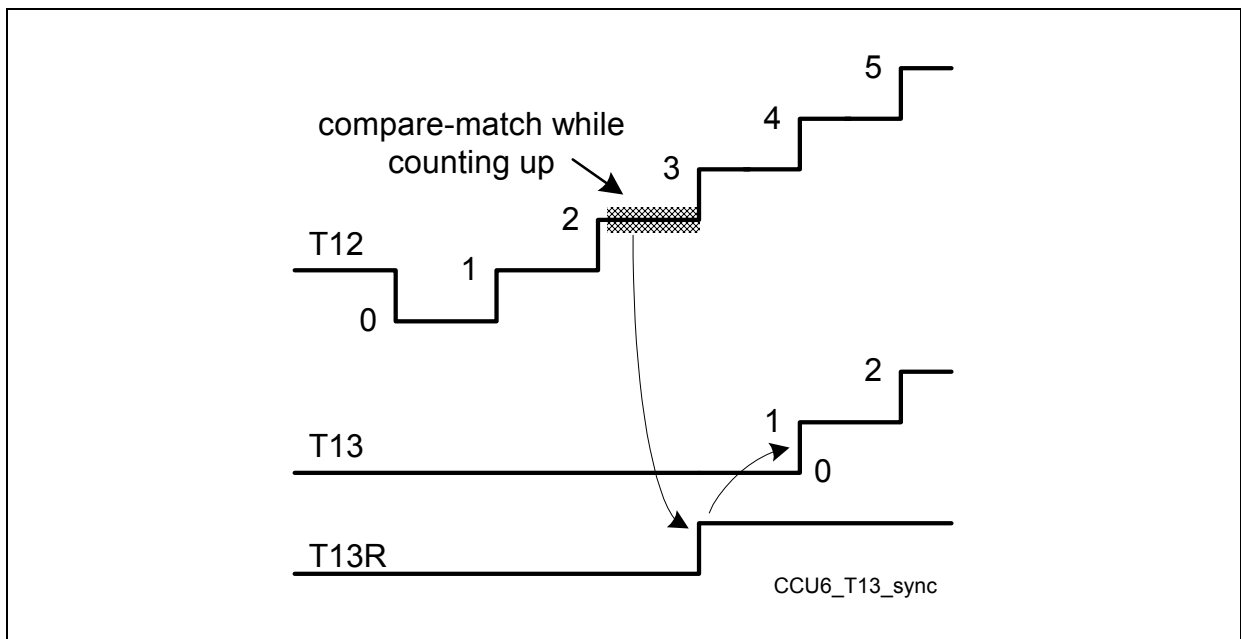

Figure 12-9 Synchronization of T13 to T12

Figure 12-9 shows the synchronization of T13 to a T12 event. The selected event in this example is a compare-match (compare value = 2) while counting up. The clocks of T12 and T13 can be different (use other prescaler factor), but in this example T12CLK is shown as equal to T13CLK for the sake of simplicity.

12.1.3 Modulation Control

The modulation control part combines the different modulation sources (CC6x_T12_o and COUT6x_T12_o are the output signals that are configured with CC6xPS/COUT6xPS; MOD_T13_o is the output signal after T13 Inverted Modulation (T13IM)). Each modulation source can be individually enabled per output line. Furthermore, the

trap functionality is taken into account to disable the modulation of the corresponding output line during the trap state (if enabled).

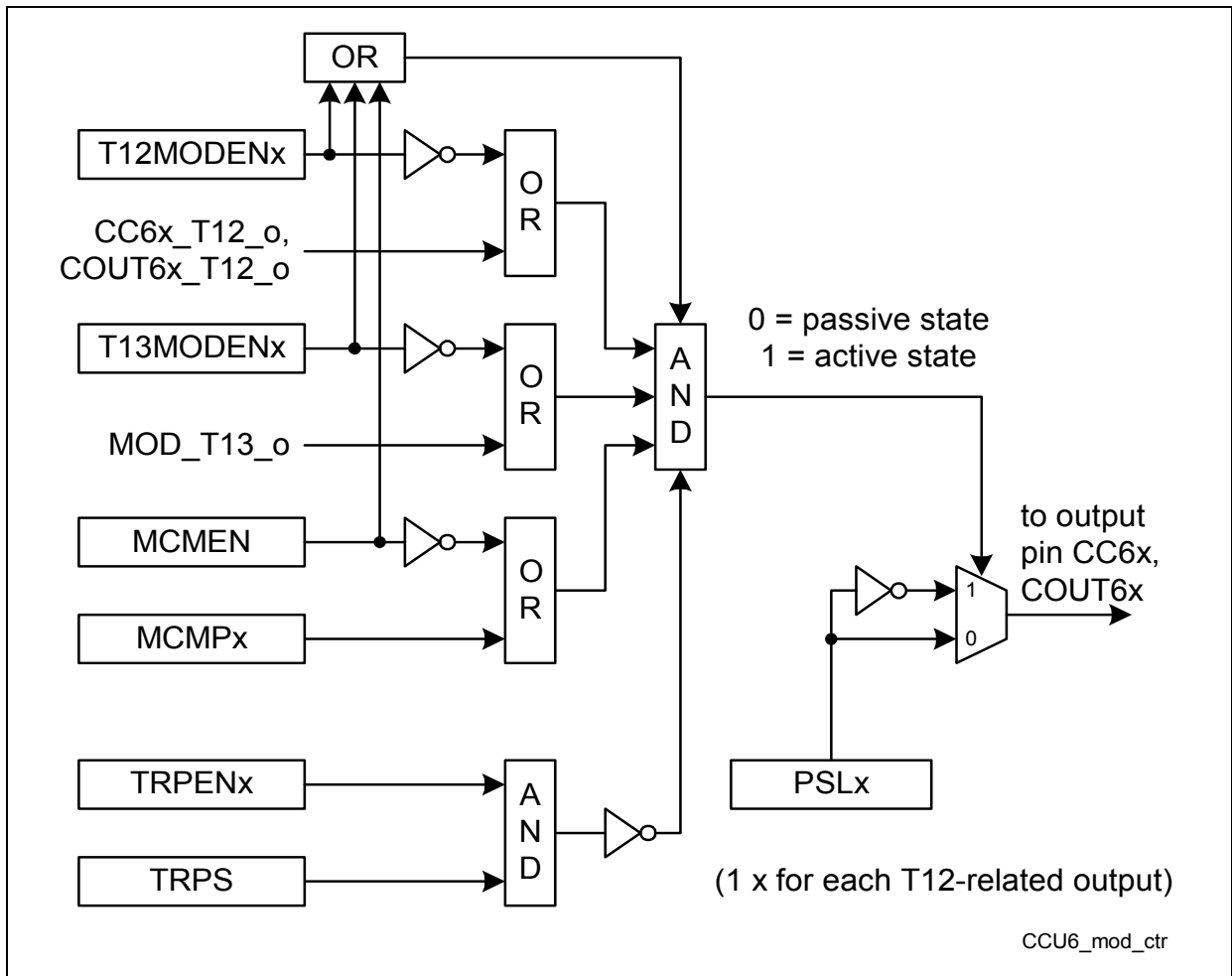

Figure 12-10 Modulation Control of T12-related Outputs

For each of the six T12-related output lines (represented by “x”) in the [Figure 12-10](#):

- T12MODENx enables the modulation by a PWM pattern generated by timer T12
- T13MODENx enables the modulation by a PWM pattern generated by timer T13
- MCMPx chooses the multi-channel patterns
- TRPENx enables the trap functionality
- PSLx defines the output level that is driven while the output is in the passive state

As shown in [Figure 12-11](#), the modulation control part for the T13-related output COUT63 combines the T13 output signal (COUT63_T13_o is the output signal that is configured by COUT63PS) and the enable bit ECT13O with the trap functionality. The output level of the passive state is selected by bit PSL63.

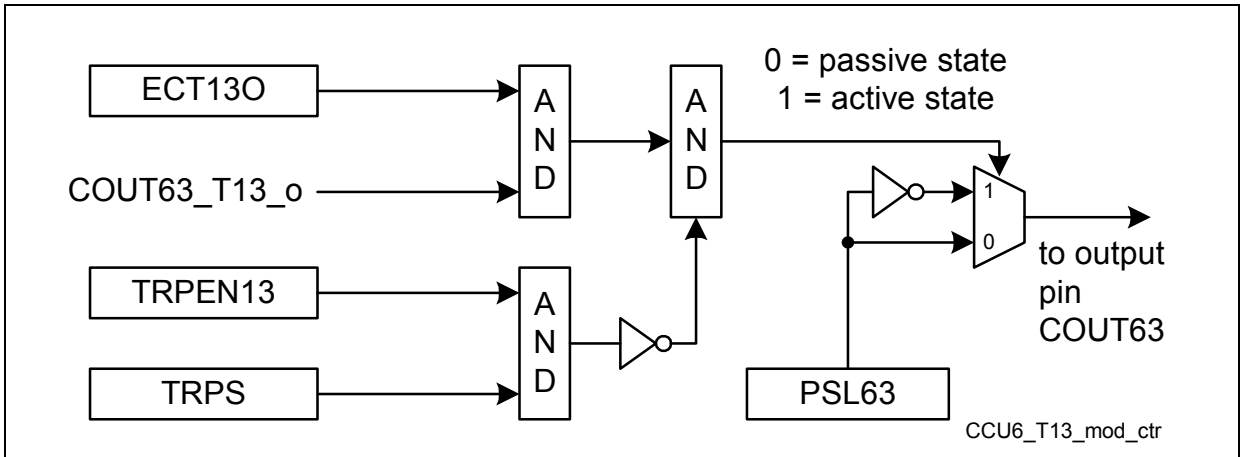

Figure 12-11 Modulation Control of the T13-related Output COUT63

Figure 12-12 shows a modulation control example for CC60 and COUT60.

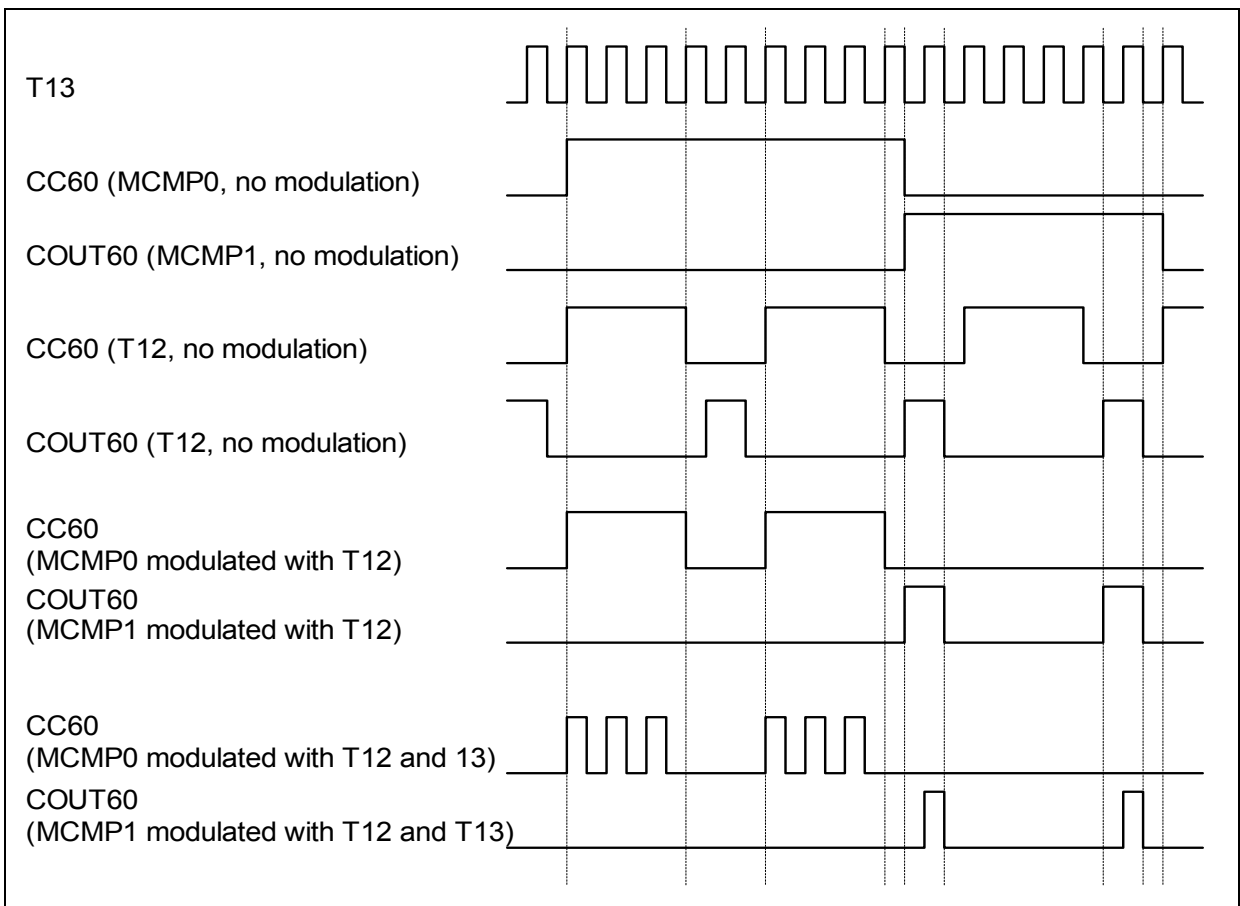

Figure 12-12 Modulation Control Example for CC60 and COUT60

12.1.4 Trap Handling

The trap functionality permits the PWM outputs to react to the state of the input pin $\overline{\text{CTRAP}}$. This functionality can be used to switch off the power devices if the trap input becomes active (e.g., as emergency stop).

During the trap state, the selected outputs are forced into the passive state and no active modulation is possible. The trap state is entered immediately by hardware if the $\overline{\text{CTRAP}}$ input signal becomes active and the trap function is enabled by bit TRPPEN. It can also be entered by software by setting bit TRPF (trap input flag), thus leading to TRPS = 1 (trap state indication flag). The trap state can be left when the input is inactive by software control and synchronized to the following events:

- TRPF is automatically reset after $\overline{\text{CTRAP}}$ becomes inactive (if TRPM2 = 0)
- TRPF must be reset by software after $\overline{\text{CTRAP}}$ becomes inactive (if TRPM2 = 1)
- synchronized to T12 PWM after TRPF is reset (T12 period-match in edge-aligned mode or one-match while counting down in center-aligned mode)
- synchronized to T13 PWM after TRPF is reset (T13 period-match)
- no synchronization to T12 or T13

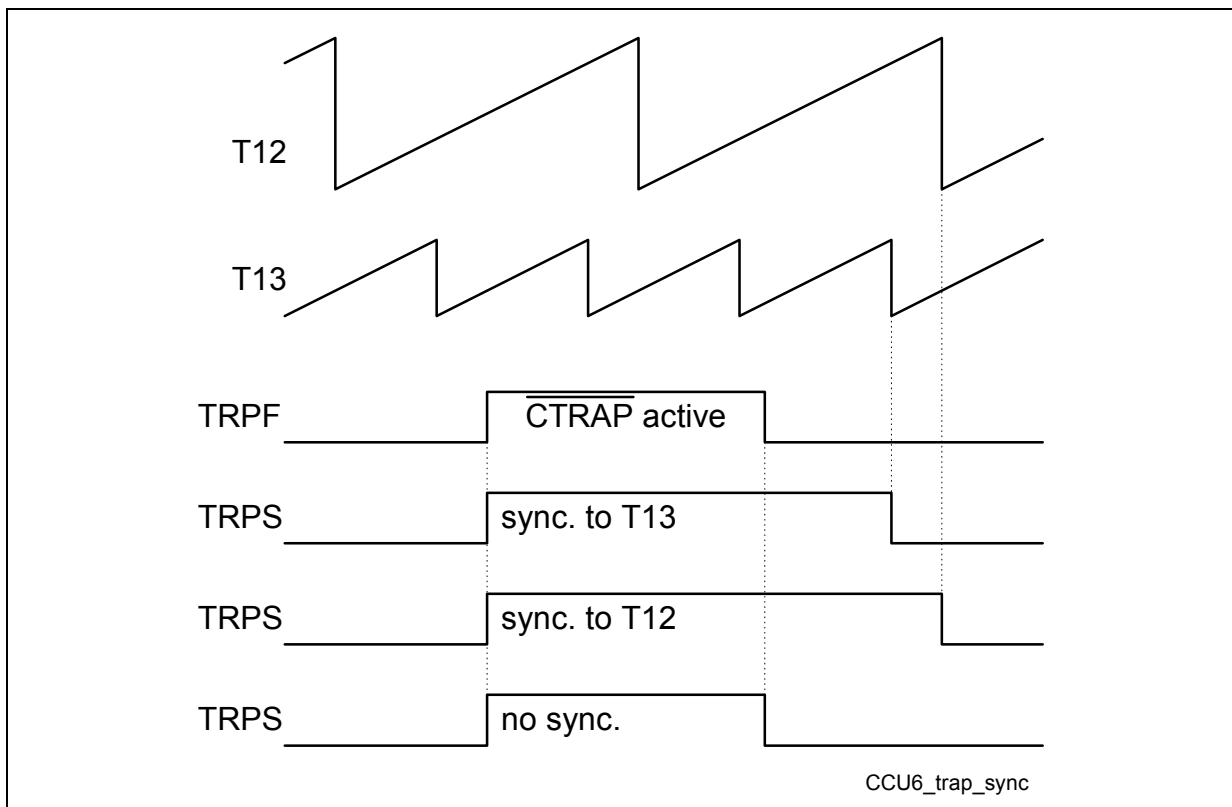

Figure 12-13 Trap State Synchronization (with TRM2 = 0)

12.1.5 Multi-Channel Mode

The multi-channel mode offers the possibility of modulating all six T12-related outputs. The bits in bit field MCMP are used to select the outputs that may become active. If the multi-channel mode is enabled (bit MCMEN = 1), only those outputs that have a 1 at the corresponding bit positions in bit field MCMP may become active.

This bit field has its own shadow bit field MCMPS, which can be written by software. The transfer of the new value in MCMPS to the bit field MCMP can be triggered by and synchronized to T12 or T13 events. This structure permits the software to write the new value, which is then taken into account by the hardware at a well-defined moment and synchronized to a PWM period. This avoids unintended pulses due to unsynchronized modulation sources (T12, T13, SW).

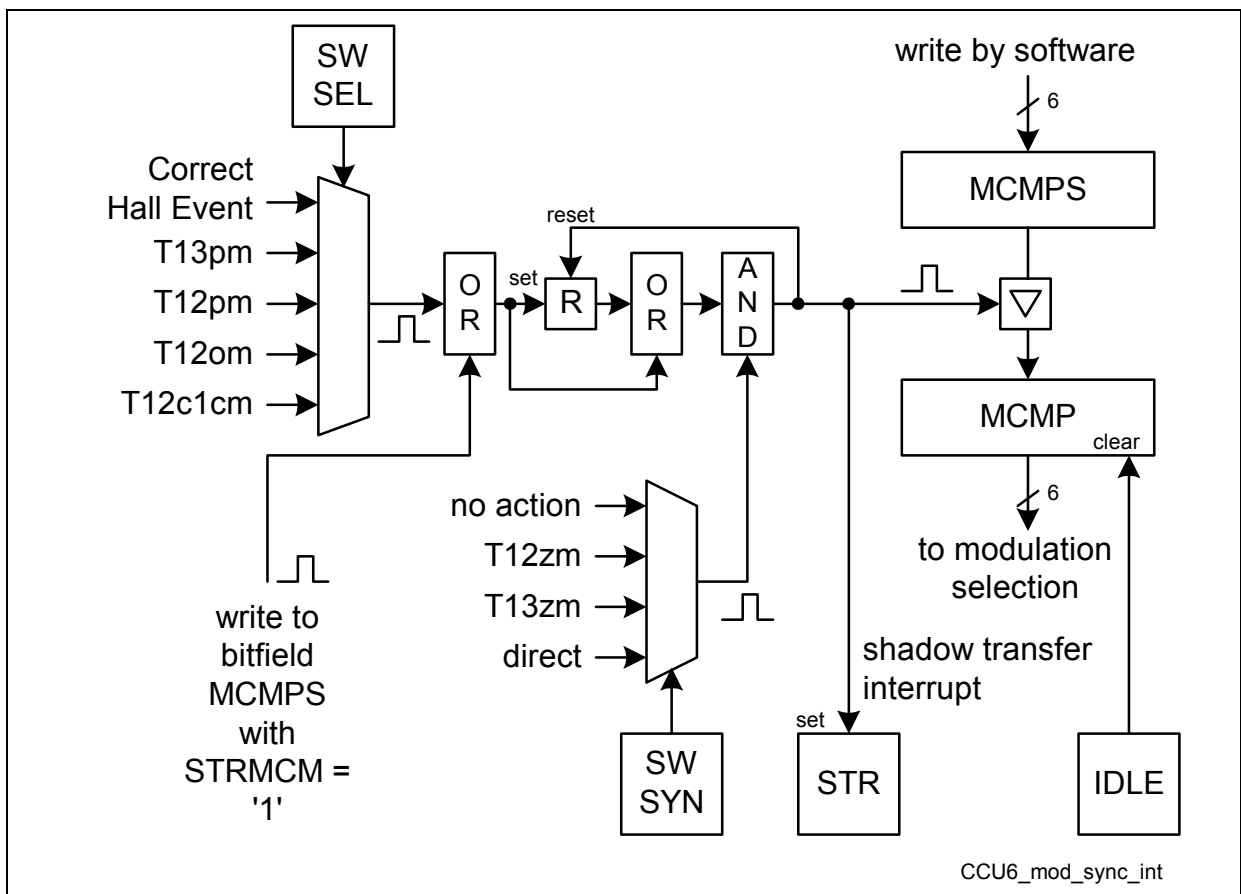

Figure 12-14 Modulation Selection and Synchronization

Figure 12-14 shows the modulation selection for the multi-channel mode. The event that triggers the update of bit field MCMP is chosen by SWSEL. If the selected switching event occurs, the reminder flag R is set. This flag monitors the update request and it is automatically reset when the update takes place. In order to synchronize the update of MCMP to a PWM generated by T12 or T13, bit field SWSYN allows the selection of the

Capture/Compare Unit 6

synchronization event, which leads to the transfer from MCMPS to MCMP. Due to this structure, an update takes place with a new PWM period.

The update can also be requested by software by writing to bit field MCMPS with the shadow transfer request bit STRMCM set. If this bit is set during the write action to the register, the flag R is automatically set. By using this, the update takes place completely under software control.

A shadow transfer interrupt can be generated when the shadow transfer takes place. The possible hardware request events are:

- a T12 period-match while counting up (T12pm)
- a T12 one-match while counting down (T12om)
- a T13 period-match (T13pm)
- a T12 compare-match of channel 1 (T12c1cm)
- a correct Hall event

The possible hardware synchronization events are:

- a T12 zero-match while counting up (T12zm)
- a T13 zero-match (T13zm)

12.1.6 Hall Sensor Mode

In **Brushless-DC** motors, the next multi-channel state values depend on the pattern of the Hall inputs. There is a strong correlation between the **Hall pattern** (CURH) and the **modulation pattern** (MCMP). Because of different machine types, the modulation pattern for driving the motor can vary. Therefore, it is beneficial to have wide flexibility in defining the correlation between the Hall pattern and the corresponding modulation pattern. The CCU6 offers this by having a register which contains the actual Hall pattern (CURHS), the next expected Hall pattern (EXPHS), and its output pattern (MCMPS). At every correct Hall event, a new Hall pattern with its corresponding output pattern can be loaded (from a predefined table) by software into the register MCMOUTS. This shadow register can also be loaded by a write action on MCMOUTS with bit STRHP = 1. In case of a phase delay (generated by T12 channel 1), a new pattern can be loaded when the multi-channel mode shadow transfer (indicated by bit STR) occurs.

12.1.6.1 Sampling of the Hall Pattern

The Hall pattern (on CCPOSx) is sampled with the module clock f_{CCU6} . By using the dead-time counter DTC0 (mode MSEL6x = 1000_B), a hardware **noise filter** can be implemented to suppress spikes on the Hall inputs. In case of a Hall event, the DTC0 is reloaded, and it starts counting and generates a delay between the detected event and the sampling point. After the counter value of 1 is reached, the CCPOSx inputs are sampled (without noise and spikes) and are compared to the current Hall pattern (CURH) and to the expected Hall pattern (EXPH). If the sampled pattern equals to the current pattern, it means that the edge on CCPOSx was due to a noise spike and no action will be triggered (implicit noise filter by delay). If the sampled pattern equals to the next expected pattern, the edge on CCPOSx was a correct Hall event, and the bit CHE is set which causes an interrupt.

If it is required that the multi-channel mode and the Hall pattern comparison work independently of timer T12, the delay generation by DTC0 can be bypassed. In this case, timer T12 can be used for other purposes.

Bit field HSYNC defines the source for the sampling of the Hall input pattern and the comparison to the current and the expected Hall pattern bit fields. The hall compare action can also be triggered by software by writing a 1 to bit SWHC. The triggering sources for the sampling by hardware include:

- Any edge at one of the inputs CCPOSx (x = 0 - 2)
- A T13 compare-match
- A T13 period-match
- A T12 period-match (while counting up)
- A T12 one-match (while counting down)
- A T12 compare-match of channel 0 (while counting up)
- A T12 compare-match of channel 0 (while counting down)

This correct Hall event can be used as a transfer request event for register MCMOUTS. The transfer from MCMOUTS to MCMOUT transfers the new CURH-pattern as well as the next EXPH-pattern. In case the sampled Hall inputs were neither the current nor the expected Hall pattern, the bit WHE (wrong Hall event) is set, which can also cause an interrupt and set the IDLE mode to clear MCMP (modulation outputs are inactive). To restart from IDLE, the transfer request of MCMOUTS must be initiated by software (bit STRHP and bit fields SWSEL/SWSYN).

12.1.6.2 Brushless-DC Control

For **Brushless-DC** motors, there is a special mode ($MSEL6x = 1000_B$) which is triggered by a change of the Hall inputs (CCPOSx). In this case, T12's channel 0 acts in capture function, channel 1 and 2 act in compare function (without output modulation), and the multi-channel-block is used to trigger the output switching together with a possible modulation of T13.

After the detection of a valid Hall edge, the T12 count value is captured to channel 0 (representing the actual motor speed) and the T12 is reset. When the timer reaches the compare value in channel 1, the next multi-channel state is switched by triggering the shadow transfer of bit field MCMP (if enabled in bit field SWEN). This trigger event can be combined with several conditions which are necessary to implement noise filtering (correct Hall event) and to synchronize the next multi-channel state to the modulation sources (avoiding spikes on the output lines). This compare function of channel 1 can be used as a phase delay for the position input to the output switching which is necessary if a sensorless back-EMF technique is used instead of Hall sensors. The compare value in channel 2 can be used as a time-out trigger (interrupt) indicating that the motor's destination speed is far below the desired value (which can be caused by an abnormal load change). In this mode, the modulation of T12 must be disabled ($T12MODENx = 0$).

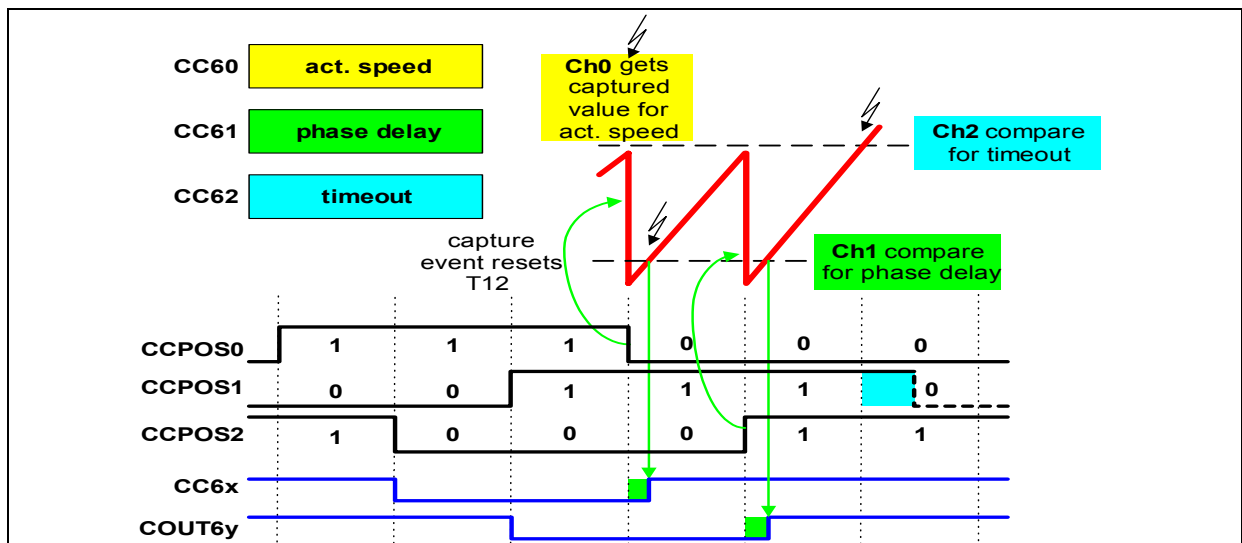

Figure 12-15 Timer T12 Brushless-DC Mode (all $MSEL6x = 1000_B$)

Capture/Compare Unit 6

Table 12-1 lists an example of block commutation in BLDC motor control. If the input signal combination CCPOS0-CCPOS2 changes its state, the outputs CC6x and COUT6x are set to their new states.

Figure 12-16 shows the block commutation in rotate left mode and **Figure 12-17** shows the block commutation in rotate right mode. These figures are derived directly from **Table 12-1**.

Table 12-1 Block Commutation Control Table

Mode	CCPOS0- CCPOS2 Inputs			CC60 - CC62 Outputs			COUT60 - COUT62 Outputs		
	CCP OS0	CCP OS1	CCP OS2	CC60	CC61	CC62	COUT6 0	COUT6 1	COUT6 2
Rotate left, 0° phase shift	1	0	1	inactive	inactive	active	inactive	active	inactive
	1	0	0	inactive	inactive	active	active	inactive	inactive
	1	1	0	inactive	active	inactive	active	inactive	inactive
	0	1	0	inactive	active	inactive	inactive	inactive	active
	0	1	1	active	inactive	inactive	inactive	inactive	active
	0	0	1	active	inactive	inactive	inactive	active	inactive
Rotate right	1	1	0	active	inactive	inactive	inactive	active	inactive
	1	0	0	active	inactive	inactive	inactive	inactive	active
	1	0	1	inactive	active	inactive	inactive	inactive	active
	0	0	1	inactive	active	inactive	active	inactive	inactive
	0	1	1	inactive	inactive	active	active	inactive	inactive
	0	1	0	inactive	inactive	active	inactive	active	inactive
Slow-down	X	X	X	inactive	inactive	inactive	active	active	active
Idle ¹⁾	X	X	X	inactive	inactive	inactive	inactive	inactive	inactive

¹⁾ In case the sampled Hall inputs were neither the current nor the expected Hall pattern, the bit WHE (Wrong Hall Event) is set, which can also cause an interrupt and set the IDLE mode to clear MCMP (modulation outputs are inactive).

Capture/Compare Unit 6

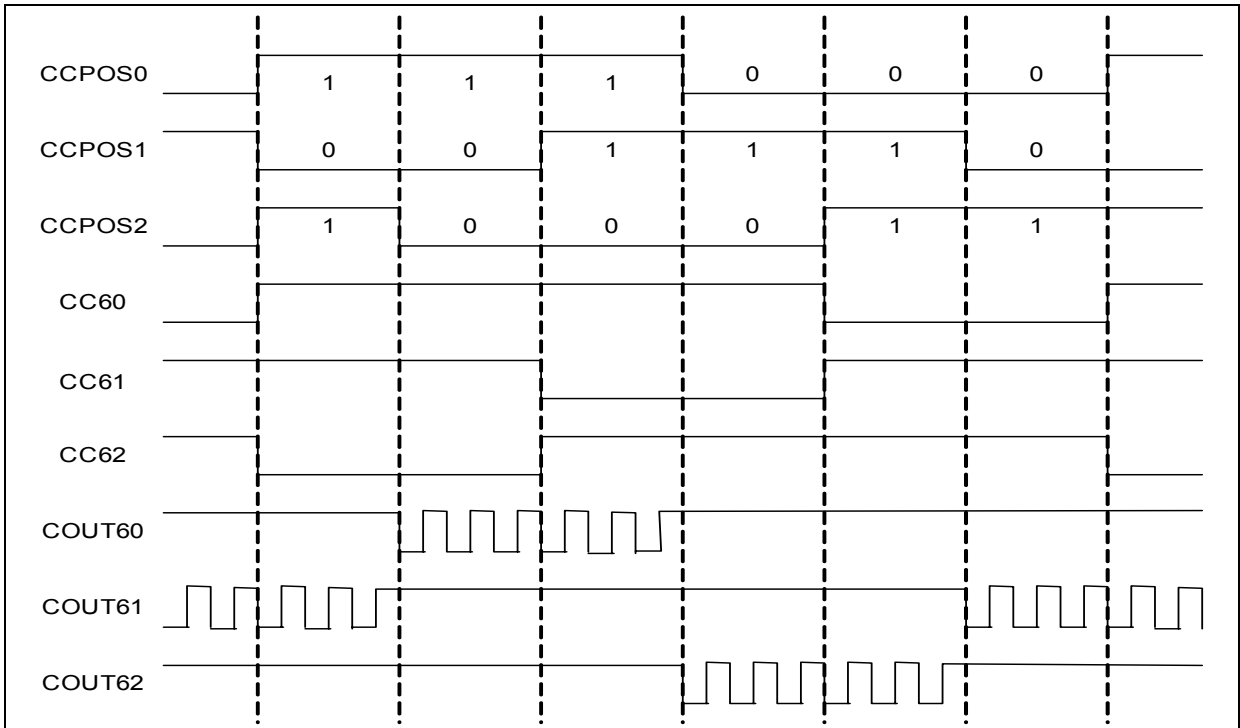

Figure 12-16 Block Commutation in Rotate Left Mode

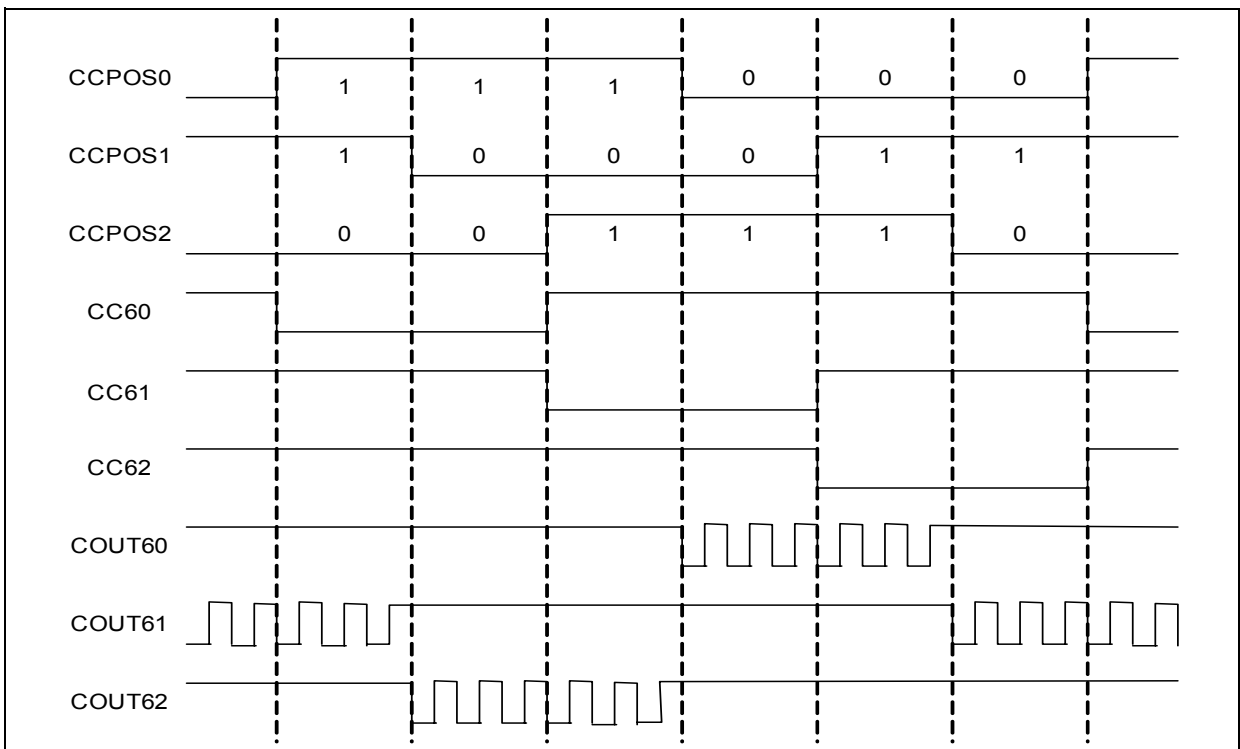

Figure 12-17 Block Commutation in Rotate Right Mode

12.1.7 Interrupt Generation

The interrupt generation can be triggered by the interrupt event or the setting of the corresponding interrupt bit in register IS by software. The interrupt is generated independently of the interrupt flag in register IS. Register IS can only be read; write actions have no impact on the contents of this register. The software can set or reset the bits individually by writing to register ISS or register ISR, respectively.

If enabled by the related interrupt enable bit in register IEN, an interrupt will be generated. The interrupt sources of the CCU6 module can be mapped to four interrupt output lines by programming the interrupt node pointer register INP.

12.1.8 Port Connection

Table 12-2 shows how bits and bit fields must be programmed for the required I/O functionality of the CCU6 I/O lines. This table also shows the values of the peripheral input select registers.

Table 12-2 CCU6 I/O Control Selection

Port Lines	PISEL Register Bit	Input/Output Control Register Bits	I/O
P3.6/CTRAP_0	ISTRP = 00 _B	P3_DIR.P6 = 0 _B	Input
P2.2/CTRAP_1	ISTRP = 01 _B	P2_DIR.P2 = 0 _B	Input
P0.2/CTRAP_2	ISTRP = 10 _B	P0_DIR.P2 = 0 _B	Input
P2.0/CCPOS0_0	ISPOS0 = 00 _B	P2_DIR.P0 = 0 _B	Input
P1.5/CCPOS0_1	ISPOS0 = 01 _B	P1_DIR.P5 = 0 _B	Input
P2.1/CCPOS1_0	ISPOS1 = 00 _B	P2_DIR.P1 = 0 _B	Input
P1.6/CCPOS1_1	ISPOS1 = 01 _B	P1_DIR.P6 = 0 _B	Input
P2.2/CCPOS2_0	ISPOS2 = 00 _B	P2_DIR.P2 = 0 _B	Input
P1.7/CCPOS2_1	ISPOS2 = 01 _B	P1_DIR.P7 = 0 _B	Input
P3.0/CC60	–	P3_DIR.P0 = 0 _B	Input
	–	P3_DIR.P0 = 1 _B	Output
		P3_ALTSEL0.P0 = 1 _B P3_ALTSEL1.P0 = 0 _B	
P3.1/COU60	–	P3_DIR.P1 = 1 _B	Output
		P3_ALTSEL0.P1 = 1 _B	
		P3_ALTSEL1.P1 = 0 _B	

Capture/Compare Unit 6
Table 12-2 CCU6 I/O Control Selection (cont'd)

Port Lines	PISEL Register Bit	Input/Output Control Register Bits	I/O
P3.2/CC61_0	ISCC61 = 00	P3_DIR.P2 = 0 _B	Input
	–	P3_DIR.P2 = 1 _B	Output
		P3_ALTSEL0.P2 = 1 _B	
		P3_ALTSEL1.P2 = 0 _B	
P0.0/CC61_1	ISCC61 = 01	P0_DIR.P0 = 0 _B	Input
	–	P0_DIR.P0 = 1 _B	Output
		P0_ALTSEL0.P0 = 0 _B	
		P0_ALTSEL1.P0 = 1 _B	
P3.3/COU61_0	–	P3_DIR.P3 = 1 _B	Output
		P3_ALTSEL0.P3 = 1 _B	
		P3_ALTSEL1.P3 = 0 _B	
P0.0/COU61_1	–	P0_DIR.P0 = 1 _B	Output
		P0_ALTSEL0.P0 = 0 _B	
		P0_ALTSEL1.P0 = 1 _B	
P3.4/CC62_0	ISCC62 = 00	P3_DIR.P4 = 0 _B	Input
	–	P3_DIR.P4 = 1 _B	Output
		P3_ALTSEL0.P4 = 1 _B	
		P3_ALTSEL1.P4 = 0 _B	
P0.4/CC62_1	ISCC62 = 01	P0_DIR.P4 = 0 _B	Input
	–	P0_DIR.P4 = 1 _B	Output
		P0_ALTSEL0.P4 = 0 _B	
		P0_ALTSEL1.P4 = 1 _B	
P3.5/COU62_0	–	P3_DIR.P5 = 1 _B	Output
		P3_ALTSEL0.P5 = 1 _B	
		P3_ALTSEL1.P5 = 0 _B	
P0.5/COU62_1	–	P0_DIR.P5 = 1 _B	Output
		P0_ALTSEL0.P5 = 0 _B	
		P0_ALTSEL1.P5 = 1 _B	

Table 12-2 CCU6 I/O Control Selection (cont'd)

Port Lines	PISEL Register Bit	Input/Output Control Register Bits	I/O
P3.7/COUT63_0	–	P3_DIR.P7 = 1 _B	Output
		P3_ALTSEL0.P7 = 1 _B	
		P3_ALTSEL1.P7 = 0 _B	
P0.3/COUT63_1	–	P0_DIR.P3 = 1 _B	Output
		P0_ALTSEL0.P3 = 0 _B	
		P0_ALTSEL1.P3 = 1 _B	
P1.6/T12HR_0	IST12HR = 00	P1_DIR.P6 = 0 _B	Input
P0.0/T12HR_1	IST12HR = 01	P0_DIR.P0 = 0 _B	Input
P2.0/T12HR_2	IST12HR = 10	P2_DIR.P0 = 0 _B	Input
P1.7/T13HR_0	IST13HR = 00	P1_DIR.P7 = 0 _B	Input
P0.1/T13HR_1	IST13HR = 01	P0_DIR.P1 = 0 _B	Input
P2.1/T13HR_2	IST13HR = 10	P2_DIR.P1 = 0 _B	Input

12.2 Register Map

The CCU6 SFRs are located in the standard memory area (RMAP = 0) and are organized into 4 pages. The CCU6_PAGE register is located at address A3_H. It contains the page value and the page control information.

CCU6_PAGE

Page Register for CCU6

Reset Value: 00_H

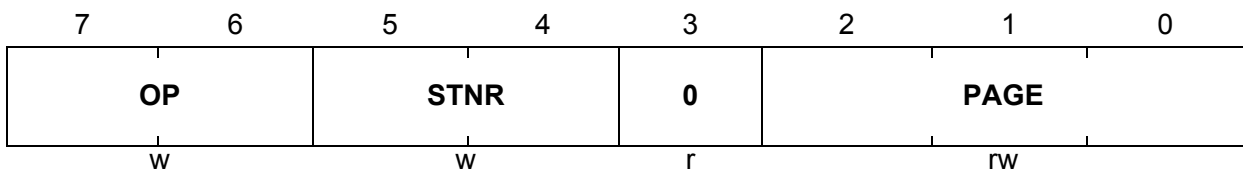

Field	Bits	Type	Description
PAGE	[2:0]	rw	<p>Page Bits</p> <p>When written, the value indicates the new page address.</p> <p>When read, the value indicates the currently active page = addr [y:x+1].</p>
STNR	[5:4]	w	<p>Storage Number</p> <p>This number indicates which storage bit field is the target of the operation defined by bit field OP.</p> <p>If OP = 10_B, the contents of PAGE are saved in STx before being overwritten with the new value.</p> <p>If OP = 11_B, the contents of PAGE are overwritten by the contents of STx. The value written to the bit positions of PAGE is ignored.</p> <p>00 ST0 is selected. 01 ST1 is selected. 10 ST2 is selected. 11 ST3 is selected.</p>

Capture/Compare Unit 6

Field	Bits	Type	Description
OP	[7:6]	w	<p>Operation</p> <p>0X Manual page mode. The value of STNR is ignored and PAGE is directly written.</p> <p>10 New page programming with automatic page saving. The value written to the bit positions of PAGE is stored. In parallel, the previous contents of PAGE are saved in the storage bit field STx indicated by STNR.</p> <p>11 Automatic restore page action. The value written to the bit positions PAGE is ignored and instead, PAGE is overwritten by the contents of the storage bit field STx indicated by STNR.</p>
0	3	r	<p>Reserved</p> <p>Returns 0 if read; should be written with 0.</p>

Capture/Compare Unit 6

All CCU6 register names described in the following sections will be referenced in other chapters of this document with the module name prefix “CCU6_”, e.g., CCU6_CC63SRL.

The addresses (non-mapped) of the CCU6 SFRs are listed in [Table 12-3](#).

Table 12-3 SFR Address List for Pages 0-3

Address	Page 0	Page 1	Page 2	Page 3
9A _H	CC63SRL	CC63RL	T12MSELL	MCMOUTL
9B _H	CC63SRH	CC63RH	T12MSELH	MCMOUTH
9C _H	TCTR4L	T12PRL	IENL	ISL
9D _H	TCTR4H	T12PRH	IENH	ISH
9E _H	MCMOUTSL	T13PRL	INPL	PISEL0L
9F _H	MCMOUTSH	T13PRH	INPH	PISEL0H
A4 _H	ISRL	T12DTCL	ISSL	PISEL2
A5 _H	ISRH	T12DTCH	ISSH	–
A6 _H	CMPMODIFL	TCTR0L	PSLR	–
A7 _H	CMPMODIFH	TCTR0H	MCMCTR	–
FA _H	CC60SRL	CC60RL	TCTR2L	T12L
FB _H	CC60SRH	CC60RH	TCTR2H	T12H
FC _H	CC61SRL	CC61RL	MODCTRL	T13L
FD _H	CC61SRH	CC61RH	MODCTRH	T13H
FE _H	CC62SRL	CC62RL	TRPCTRL	CMPSTATL
FF _H	CC62SRH	CC62RH	TRPCTRH	CMPSTATH

12.3 Register Description

Table 12-4 shows all registers associated with the CCU6 module.

Table 12-4 CCU6 Module Registers

Register Short Name	Register Full Name	Description see
System Registers		
PISEL0L	Port Input Select Register 0 Low	Page 12-31
PISEL0H	Port Input Select Register 0 High	Page 12-33
PISEL2	Port Input Select Register 2	Page 12-34
T12 Registers		
T12L	Timer T12 Counter Register Low	Page 12-35
T12H	Timer T12 Counter Register High	Page 12-35
T12PRL	Timer T12 Period Register Low	Page 12-36
T12PRH	Timer T12 Period Register High	Page 12-36
CC6xRL	Capture/Compare Register for Channel CC6x Low	Page 12-37
CC6xRH	Capture/Compare Register for Channel CC6x High	Page 12-37
CC6xSRL	Capture/Compare Shadow Register for Channel CC6x Low	Page 12-38
CC6xSRH	Capture/Compare Shadow Register for Channel CC6x High	Page 12-38
T12DTCL	Dead-Time Control Register for Timer T12 Low	Page 12-39
T12DTCH	Dead-Time Control Register for Timer T12 High	Page 12-39
T13 Registers		
T13L	Timer T13 Counter Register Low	Page 12-41
T13H	Timer T13 Counter Register High	Page 12-41
T13PRL	Timer T13 Period Register Low	Page 12-42
T13PRH	Timer T13 Period Register High	Page 12-42
CC63RL	Capture/Compare Register for Channel CC63 Low	Page 12-43
CC63RH	Capture/Compare Register for Channel CC63 High	Page 12-44

Table 12-4 CCU6 Module Registers (cont'd)

Register Short Name	Register Full Name	Description see
CC63SRL	Capture/Compare Shadow Register for Channel CC63 Low	Page 12-44
CC63SRH	Capture/Compare Shadow Register for Channel CC63 High	Page 12-44
CCU6 Control Registers		
CMPSTATL	Compare State Register Low	Page 12-45
CMPSTATH	Compare State Register High	Page 12-46
CMPMODIFL	Compare State Modification Register Low	Page 12-47
CMPMODIFH	Compare State Modification Register High	Page 12-47
TCTR0L	Timer Control Register 0 Low	Page 12-48
TCTR0H	Timer Control Register 0 High	Page 12-49
TCTR2L	Timer Control Register 2 Low	Page 12-52
TCTR2H	Timer Control Register 2 High	Page 12-54
TCTR4L	Timer Control Register 4 Low	Page 12-55
TCTR4H	Timer Control Register 4 High	Page 12-56
Modulation Control Registers		
MODCTRL	Modulation Control Register Low	Page 12-57
MODCTRH	Modulation Control Register High	Page 12-58
TRPCTRL	Trap Control Register Low	Page 12-60
TRPCTRH	Trap Control Register High	Page 12-61
PSLR	Passive State Level Register	Page 12-63
MCMOUTSL	Multi_Channel Mode Output Shadow Register Low	Page 12-65
MCMOUTSH	Multi_Channel Mode Output Shadow Register High	Page 12-66
MCMOUTL	Multi_Channel Mode Output Register Low	Page 12-67
MCMOUTH	Multi_Channel Mode Output Register High	Page 12-69
MCMCTR	Multi_Channel Mode Control Register	Page 12-70
T12MSELL	T12 Capture/Compare Mode Select Register Low	Page 12-72

Table 12-4 CCU6 Module Registers (cont'd)

Register Short Name	Register Full Name	Description see
T12MSELH	T12 Capture/Compare Mode Select Register High	Page 12-73
Interrupt Control Registers		
ISL	Interrupt Status Register Low	Page 12-77
ISH	Interrupt Status Register High	Page 12-78
ISSL	Interrupt Status Set Register Low	Page 12-80
ISSH	Interrupt Status Set Register High	Page 12-81
ISRL	Interrupt Status Reset Register Low	Page 12-82
ISRH	Interrupt Status Reset Register High	Page 12-83
IENL	Interrupt Enable Register Low	Page 12-84
IENH	Interrupt Enable Register High	Page 12-85
INPL	Interrupt Node Pointer Register Low	Page 12-88
INPH	Interrupt Node Pointer Register High	Page 12-89

Note: For all CCU6 registers: the write-only bit positions (indicated by “w”) always deliver the value of 0 when they are read out. If a hardware and a software request to modify a bit occur simultaneously, the software wins.

12.3.1 System Registers

12.3.1.1 Port Input Selection

Registers PISEL0 and PISEL2 contain bit fields that select the actual input signals for the module inputs. This permits the pin functionality of the device to be adapted as per the application’s requirements. The output pins are chosen according to the registers in the ports.

PISEL0L

Port Input Select Register 0 Low

Reset Value: 00_H

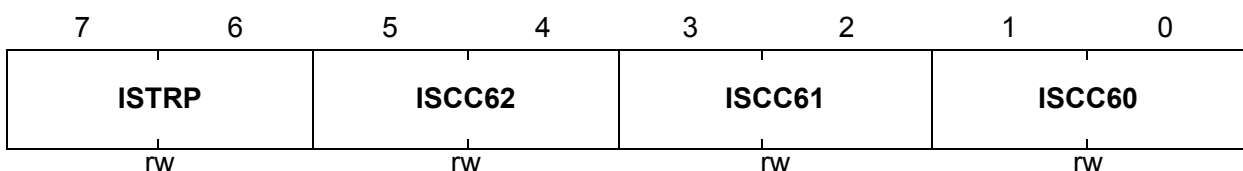

Capture/Compare Unit 6

Field	Bits	Type	Description
ISCC60	[1:0]	rw	<p>Input Select for CC60</p> <p>This bit field defines the port pin that is used for the CC60 capture input signal.</p> <p>00 The input pin is selected for CC60_0. 01 Reserved 10 Reserved 11 Reserved</p>
ISCC61	[3:2]	rw	<p>Input Select for CC61</p> <p>This bit field defines the port pin that is used for the CC61 capture input signal.</p> <p>00 The input pin is selected for CC61_0. 01 The input pin is selected for CC61_1. 10 Reserved 11 Reserved</p>
ISCC62	[5:4]	rw	<p>Input Select for CC62</p> <p>This bit field defines the port pin that is used for the CC62 capture input signal.</p> <p>00 The input pin is selected for CC62_0. 01 The input pin is selected for CC62_1. 10 Reserved 11 Reserved</p>
ISTRP	[7:6]	rw	<p>Input Select for CTRAP</p> <p>This bit field defines the port pin that is used for the CTRAP input signal.</p> <p>00 The input pin is selected for <u>CTRAP_0</u>. 01 The input pin is selected for <u>CTRAP_1</u>. 10 The input pin is selected for <u>CTRAP_2</u>. 11 Reserved</p>

PISEL0H

Port Input Select Register 0 High

Reset Value: 00_H

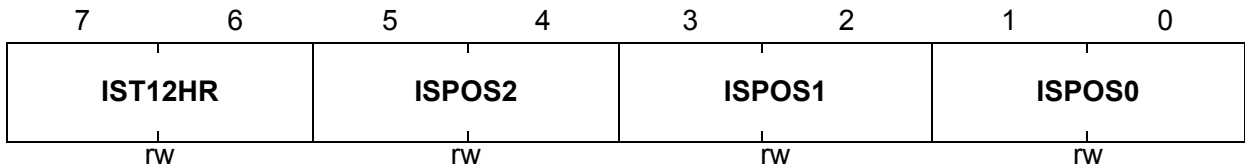

Field	Bits	Type	Description
ISPOS0	[1:0]	rw	<p>Input Select for CCPOS0 This bit field defines the port pin that is used for the CCPOS0 input signal.</p> <p>00 The input pin is selected for CCPOS0_0. 01 The input pin is selected for CCPOS0_1. 10 Reserved 11 Reserved</p>
ISPOS1	[3:2]	rw	<p>Input Select for CCPOS1 This bit field defines the port pin that is used for the CCPOS1 input signal.</p> <p>00 The input pin is selected for CCPOS1_0. 01 The input pin is selected for CCPOS1_1. 10 Reserved 11 Reserved</p>
ISPOS2	[5:4]	rw	<p>Input Select for CCPOS2 This bit field defines the port pin that is used for the CCPOS2 input signal.</p> <p>00 The input pin is selected for CCPOS2_0. 01 The input pin is selected for CCPOS2_1. 10 Reserved 11 Reserved</p>
IST12HR	[7:6]	rw	<p>Input Select for T12HR This bit field defines the port pin that is used for the T12HR input signal.</p> <p>00 The input pin is selected for T12HR_0. 01 The input pin is selected for T12HR_1. 10 The input pin is selected for T12HR_2. 11 Reserved</p>

PISEL2

Port Input Select Register 2

Reset Value: 00_H

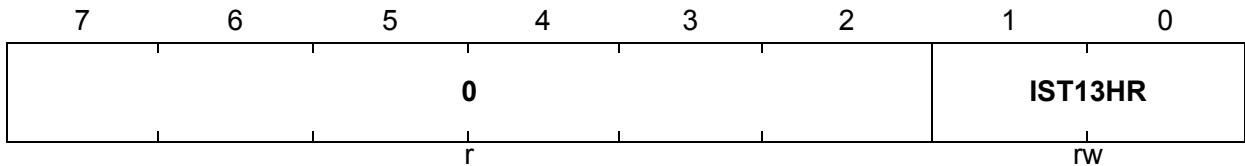

Field	Bits	Type	Description
IST13HR	[1:0]	rw	Input Select for T13HR This bit field defines the port pin that is used for the T13HR input signal. 00 The input pin is selected for T13HR_0. 01 The input pin is selected for T13HR_1. 10 The input pin is selected for T13HR_2. 11 Reserved
0	[7:2]	r	Reserved Returns 0 if read; should be written with 0.

12.3.2 Timer T12 – Related Registers

The generation of the patterns for a 3-channel PWM is based on timer T12. The registers related to timer T12 can be concurrently updated (with well-defined conditions) in order to ensure consistency of the three PWM channels.

Timer T12 supports capture and compare modes, which can be independently selected for its three channels CC60, CC61 and CC62.

T12L

Timer T12 Counter Register Low

Reset Value: 00_H

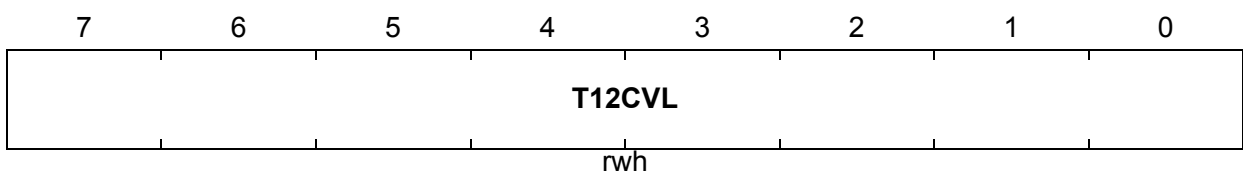

T12H

Timer T12 Counter Register High

Reset Value: 00_H

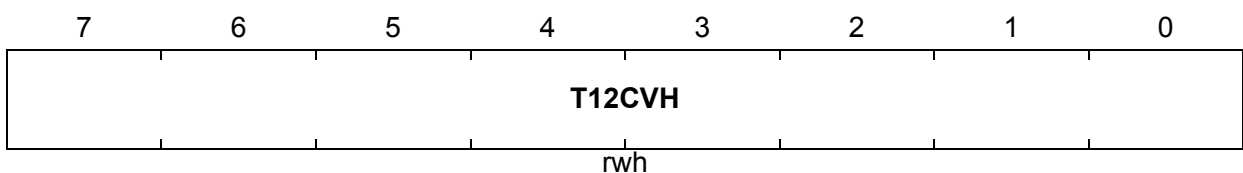

Field	Bits	Type	Description
T12CV	[7:0] of T12L, [7:0] of T12H	rwh	Timer T12 Counter Value This register represents the 16-bit counter value of timer T12.

Note: Once timer T12 is stopped, the internal clock divider is reset in order to ensure reproducible timings and delays.

T12PRL

Timer T12 Period Register Low

Reset Value: 00_H

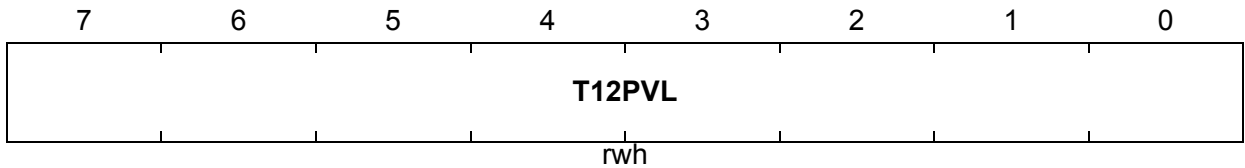

T12PRH

Timer T12 Period Register High

Reset Value: 00_H

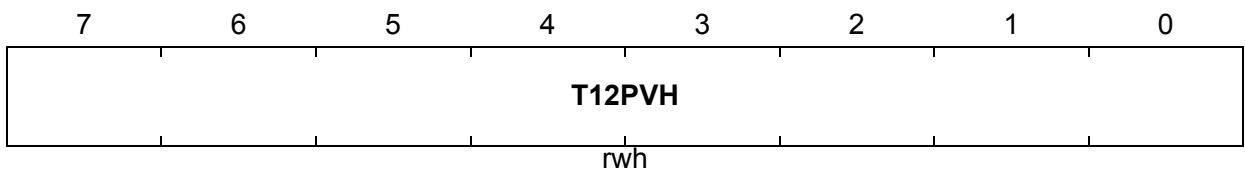

Field	Bits	Type	Description
T12PV	[7:0] of T12PRL, [7:0] of T12PRH	rwh	T12 Period Value The value T12PV defines the counter value for T12, which leads to a period-match. On reaching this value, the timer T12 is set to zero (edge-aligned mode) or changes its count direction to down counting (center-aligned mode).

Capture/Compare Unit 6

CC6xRL (x = 0 - 2)

Capture/Compare Register for Channel CC6x Low

Reset Value: 00_H

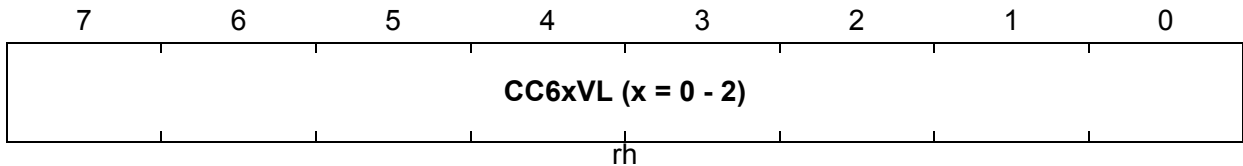

CC6xRH (x = 0 - 2)

Capture/Compare Register for Channel CC6x High

Reset Value: 00_H

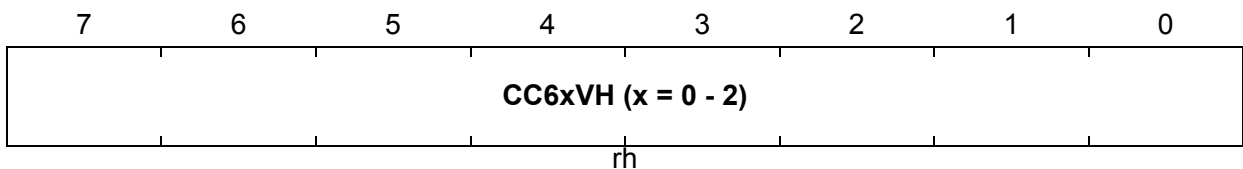

Field	Bits	Type	Description
CC6xV (x = 0 - 2)	[7:0] of CC6xRL, [7:0] of CC6xRH	rh	Channel x Capture/Compare Value In compare mode, the bit fields CC6xV contain the values that are compared to the T12 counter value. In capture mode, the captured value of T12 can be read from these registers.

Capture/Compare Unit 6

CC6xSRL (x = 0 - 2)

Capture/Compare Shadow Register for Channel CC6x Low

Reset Value: 00_H

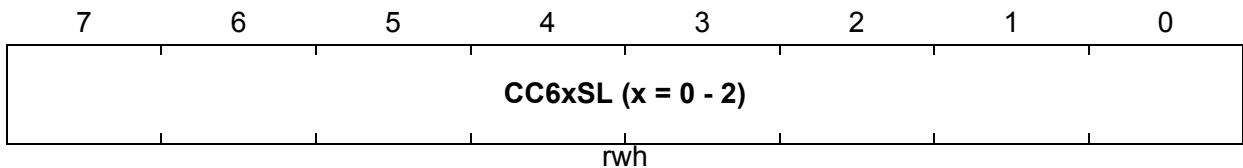

CC6xSRH (x = 0 - 2)

Capture/Compare Shadow Register for Channel CC6x High

Reset Value: 00_H

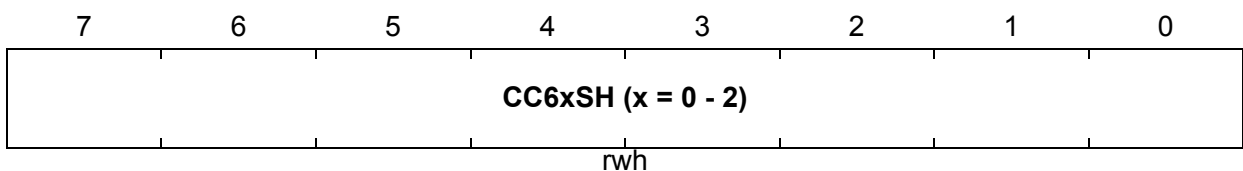

Field	Bits	Type	Description
CC6xS (x = 0 - 2)	[7:0] of CC6xSRL, [7:0] of CC6xSRH	rwh	Shadow Register for Channel x Capture/Compare Value In compare mode, the contents of bit fields CC6xS are transferred to the bit fields CC6xV during a shadow transfer. In capture mode, the captured value of T12 can be read from these registers.

T12DTCL

Dead-Time Control Register for Timer T12 Low

Reset Value: 00_H

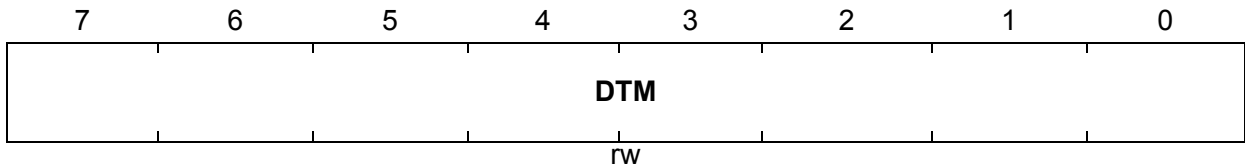

Field	Bits	Type	Description
DTM	[7:0]	rw	Dead-Time Bit field DTM determines the programmable delay between switching from the passive state to the active state of the selected outputs. The switching from the active state to the passive state is not delayed.

T12DTCH

Dead-Time Control Register for Timer T12 High

Reset Value: 00_H

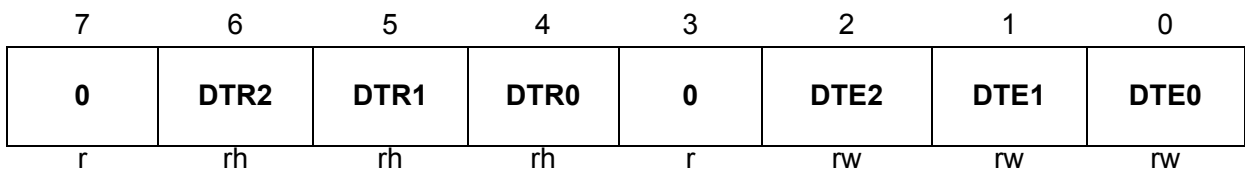

Field	Bits	Type	Description
DTE0 DTE1 DTE2	0 1 2	rw	Dead-Time Enable Bits Bits DTE _x (x = 0 - 2) enable and disable the dead-time generation for each compare channel (0, 1, 2) of timer T12. 0 Dead-time generation is disabled. The corresponding outputs switch from the passive state to the active state (according to the actual compare status) without any delay. 1 Dead-time generation is enabled. The corresponding outputs switch from the passive state to the active state (according to the compare status) with the delay programmed in bit field DTM.

Capture/Compare Unit 6

Field	Bits	Type	Description
DTR0 DTR1 DTR2	4 5 6	rh	Dead-Time Run Indication Bits Bits DTRx (x = 0 - 2) indicate the status of the dead-time generation for each compare channel (0, 1, 2) of timer T12. 0 The value of the corresponding dead-time counter channel is 0. 1 The value of the corresponding dead-time counter channel is not 0.
0	3, 7	r	Reserved Returns 0 if read; should be written with 0.

*Note: The dead-time counters are clocked with the same frequency as T12. This structure allows symmetrical dead-time generation in center-aligned and in edge-aligned PWM mode. A duty cycle of 50% leads to CC6x; COU6x is switched on for: 0.5 * period - dead-time.*

Note: The dead-time counters are not reset by bit T12RES, but by bit DTRES.

12.3.3 Timer T13 – Related Registers

The generation of the patterns for a single-channel PWM is based on timer T13. The registers related to timer T13 can be concurrently updated (with well-defined conditions) in order to ensure consistency of the PWM signal. Timer T13 can be synchronized to several timer T12 events.

Timer T13 supports only compare mode on its compare channel CC63.

T13L

Timer T13 Counter Register Low

Reset Value: 00_H

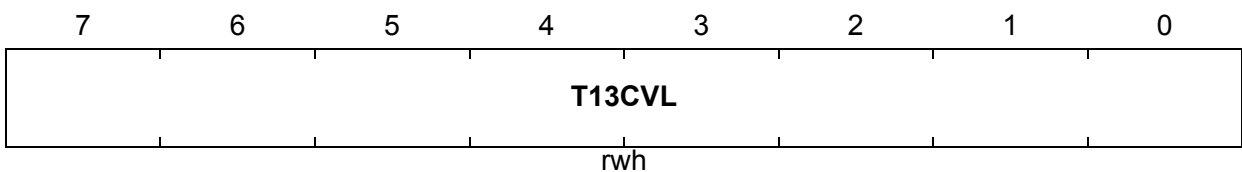

T13H

Timer T13 Counter Register High

Reset Value: 00_H

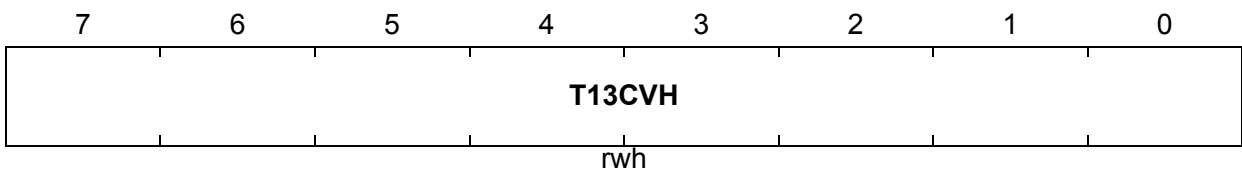

Field	Bits	Type	Description
T13CV	[7:0] of T13L, [7:0] of T13H	rwh	Timer T13 Counter Value This register represents the 16-bit counter value of timer T13.

Note: Once timer T13 is stopped, the internal clock divider is reset in order to ensure reproducible timings and delays.

T13PRL

Timer T13 Period Register Low

Reset Value: 00_H

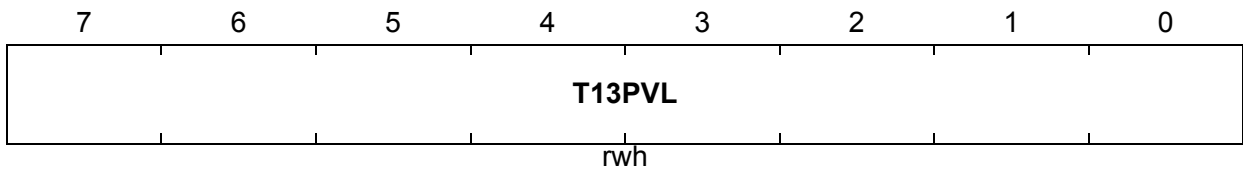

T13PRH

Timer T13 Period Register High

Reset Value: 00_H

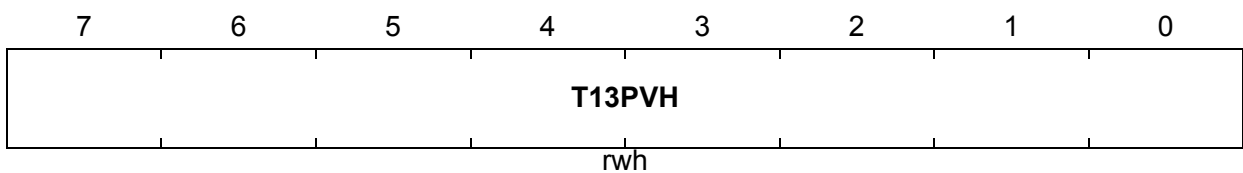

Field	Bits	Type	Description
T13PV	[7:0] of T13PRL, [7:0] of T13PRH	rwh	T13 Period Value The value T13PV defines the counter value for T13, which leads to a period-match. On reaching this value, the timer T13 is set to zero.

Capture/Compare Unit 6

CC63RL

Capture/Compare Register for Channel CC63 Low

Reset Value: 00_H

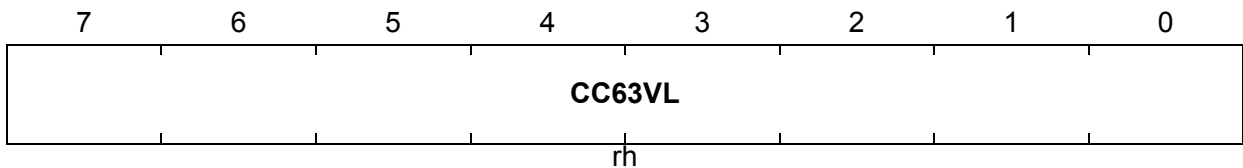

CC63RH

Capture/Compare Register for Channel CC63 High

Reset Value: 00_H

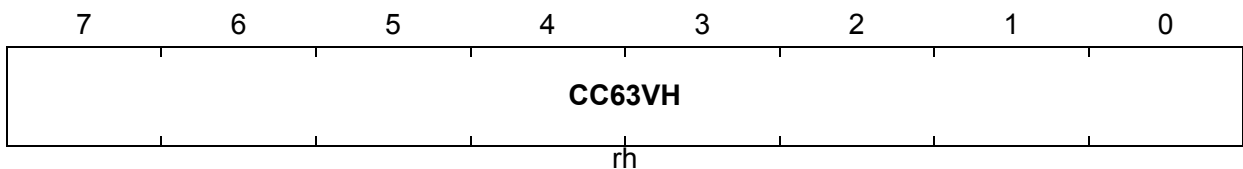

Field	Bits	Type	Description
CC63V	[7:0] of CC63RL, [7:0] of CC63RH	rh	Channel CC63 Compare Value The bit fields CC63V contain the values that are compared to the T13 counter value.

Capture/Compare Unit 6

CC63SRL

Capture/Compare Shadow Register for Channel CC63 Low

Reset Value: 00_H

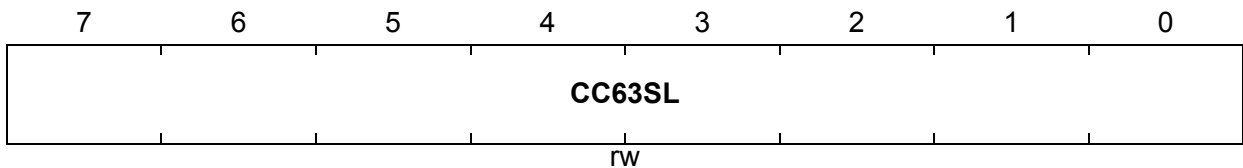

CC63SRH

Capture/Compare Shadow Register for Channel CC63 High

Reset Value: 00_H

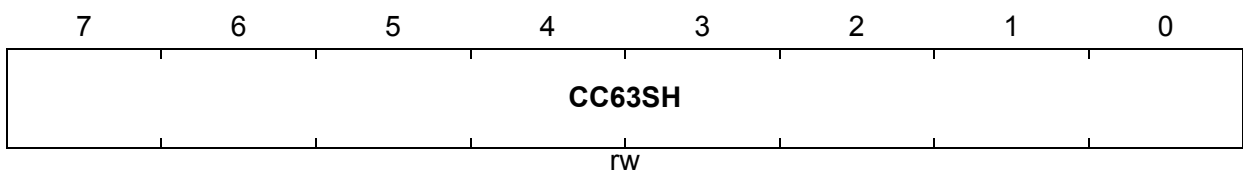

Field	Bits	Type	Description
CC63S	[7:0] of CC63SRL, [7:0] of CC63SRH	rw	Shadow Register for Channel CC63 Compare Value The contents of bit fields CC63S are transferred to the bit fields CC63V during a shadow transfer.

12.3.4 Capture/Compare Control Registers

Register CMPSTAT contains status bits that monitor the current capture and compare state, and control bits that define the active/passive state of the compare channels.

CMPSTATL

Compare State Register Low

Reset Value: 00_H

7	6	5	4	3	2	1	0
0	CC 63ST	CC POS 2	CC POS 1	CC POS 0	CC 62ST	CC 61ST	CC 60ST
r	rh	rh	rh	rh	rh	rh	rh

Field	Bits	Type	Description
CC60ST CC61ST CC62ST CC63ST 1)	0 1 2 6	rh	Capture/Compare State Bits Bits CC6xST monitor the state of the capture/compare channels. Bits CC6xST (x = 0 - 2) are related to T12; bit CC63ST is related to T13. 0 In compare mode, the timer count is less than the compare value. In capture mode, the selected edge has not been detected since the bit was reset by software. 1 In compare mode, the counter value is greater than or equal to the compare value. In capture mode, the selected edge has been detected.
CCPOS0 CCPOS1 CCPOS2	3 4 5	rh	Sampled Hall Pattern Bits Bits CCPOSx (x = 0 - 2) indicate the value of the input Hall pattern that has been compared to the current and expected value. The value is sampled when the event hcrdy (Hall compare ready) occurs. 0 The input CCPOSx has been sampled as 0. 1 The input CCPOSx has been sampled as 1.
0	7	r	Reserved Returns 0 if read; should be written with 0.

1) These bits are set and reset according to the T12 and T13 switching rules.

Capture/Compare Unit 6

CMPSTATH

Compare State Register High

Reset Value: 00_H

7	6	5	4	3	2	1	0
T13 IM	C OUT63PS	C OUT62PS	CC 62PS	C OUT61PS	CC 61PS	C OUT60PS	CC 60PS
rwh	rwh	rwh	rwh	rwh	rwh	rwh	rwh

Field	Bits	Type	Description
CC60PS CC61PS CC62PS COUT60PS COUT61PS COUT62PS COUT63PS 1)	0 2 4 1 3 5 6	rwh	Passive State Select for Compare Outputs Bits CC6xPS and COUT6xPS (x = 0 - 2) select the state of the corresponding compare channel, which is considered to be the passive state. During the passive state, the passive level (defined in register PSLR) is driven by the output pin. Bits CC6xPS and COUT6xPS are related to T12, while bit CC63PS is related to T13. 0 The corresponding compare output drives passive level while CC6xST is 0. 1 The corresponding compare output drives passive level while CC6xST is 1. In capture mode, these bits are not used.
T13IM ²⁾	7	rwh	T13 Inverted Modulation Bit T13IM inverts the T13 signal for the modulation of the CC6x and COUT6x (x = 0 - 2) signals. 0 T13 output is not inverted. 1 T13 output is inverted for further modulation.

1) These bits have shadow bits and are updated in parallel to the capture/compare registers of T12 and T13, respectively. A read action targets the actually used values, whereas a write action targets the shadow bits.

2) This bit has a shadow bit and is updated in parallel to the compare and period registers of T13. A read action targets the actually used values, whereas a write action targets the shadow bit.

Capture/Compare Unit 6

Register CMPMODIF contains control bits that allow modification by software of the capture/compare state bits.

CMPMODIFL

Compare State Modification Register Low

Reset Value: 00_H

7	6	5	4	3	2	1	0
0	MCC 63S	0			MCC 62S	MCC 61S	MCC 60S
r	w	r			w	w	w

CMPMODIFH

Compare State Modification Register High

Reset Value: 00_H

7	6	5	4	3	2	1	0
0	MCC 63R	0			MCC 62R	MCC 61R	MCC 60R
r	w	r			w	w	w

Field	Bits	Type	Description
MCC60S ¹⁾	0	w	Capture/Compare Status Modification Bits These bits are used to set (MCC6xS) or reset (MCC6xR) the corresponding CC6xST bits by software. This feature allows the user to individually change the status of the output lines by software, e.g., when the corresponding compare timer is stopped. This enables a manipulation of CC6xST bits by a single data write action. MCC6xR, MCC6xS = 0,0 Bit CC6xST is not changed. 0,1 Bit CC6xST is set. 1,0 Bit CC6xST is reset. 1,1 Reserved (toggle)
MCC61S ¹⁾	1		
MCC62S ¹⁾	2		
MCC63S ¹⁾	6		
MCC60R ²⁾	0		
MCC61R ²⁾	1		
MCC62R ²⁾	2		
MCC63R ²⁾	6		
0	[5:3], 7	r	Reserved Returns 0 if read; should be written with 0.

¹⁾ This bit field is contained in the Compare State Modification Register Low.

²⁾ This bit field is contained in the Compare State Modification Register High.

Capture/Compare Unit 6

Register TCTR0 controls the basic functionality of both timers T12 and T13.

TCTR0L

Timer Control Register 0 Low

Reset Value: 00_H

7	6	5	4	3	2	1	0
CTM	CDIR	STE12	T12R	T12 PRE	T12CLK		
rw	rh	rh	rh	rw	rw		

Field	Bits	Type	Description
T12CLK	[2:0]	rw	<p>Timer T12 Input Clock Select Selects the input clock for timer T12 which is derived from the peripheral clock according to the equation $f_{T12} = f_{CCU6}/2^{<T12CLK>}$.</p> <p>000 $f_{T12} = f_{CCU6}$ 001 $f_{T12} = f_{CCU6}/2$ 010 $f_{T12} = f_{CCU6}/4$ 011 $f_{T12} = f_{CCU6}/8$ 100 $f_{T12} = f_{CCU6}/16$ 101 $f_{T12} = f_{CCU6}/32$ 110 $f_{T12} = f_{CCU6}/64$ 111 $f_{T12} = f_{CCU6}/128$</p>
T12PRE	3	rw	<p>Timer T12 Prescaler Bit In order to support higher clock frequencies, an additional prescaler factor of 1/256 can be enabled for the prescaler for T12.</p> <p>0 The additional prescaler for T12 is disabled. 1 The additional prescaler for T12 is enabled.</p>
T12R¹⁾	4	rh	<p>Timer T12 Run Bit T12R starts and stops timer T12. It is set/reset by software by setting bit T12RR or T12RS, or it is reset by hardware according to the function defined by bit T12SSC.</p> <p>0 Timer T12 is stopped. 1 Timer T12 is running.</p>

Capture/Compare Unit 6

Field	Bits	Type	Description
STE12	5	rh	<p>Timer T12 Shadow Transfer Enable</p> <p>Bit STE12 enables or disables the shadow transfer of the T12 period value, the compare values and passive state select bits and levels from their shadow registers to the actual registers if a T12 shadow transfer event is detected. Bit STE12 is cleared by hardware after the shadow transfer.</p> <p>A T12 shadow transfer event is a period-match while counting up or a one-match while counting down.</p> <p>0 The shadow register transfer is disabled. 1 The shadow register transfer is enabled.</p>
CDIR	6	rh	<p>Count Direction of Timer T12</p> <p>This bit is set/reset according to the counting rules of T12.</p> <p>0 T12 counts up. 1 T12 counts down.</p>
CTM	7	rw	<p>T12 Operating Mode</p> <p>0 Edge-aligned mode: T12 always counts up and continues counting from zero after reaching the period value.</p> <p>1 Center-aligned mode: T12 counts down after detecting a period-match and counts up after detecting a one-match.</p>

¹⁾ A concurrent set/reset action on T12R (from T12SSC, T12RR or T12RS) will have no effect. The bit T12R will remain unchanged.

TCTR0H

Timer Control Register 0 High

Reset Value: 00_H

7	6	5	4	3	2	1	0
0	STE 13	T13R	T13 PRE	T13CLK			
r	rh	rh	rw	rw			

Field	Bits	Type	Description
T13CLK	[2:0]	rw	Timer T13 Input Clock Select Selects the input clock for timer T13 which is derived from the peripheral clock according to the equation $f_{T13} = f_{CCU6}/2^{<T13CLK>}$. 000 $f_{T13} = f_{CCU6}$ 001 $f_{T13} = f_{CCU6}/2$ 010 $f_{T13} = f_{CCU6}/4$ 011 $f_{T13} = f_{CCU6}/8$ 100 $f_{T13} = f_{CCU6}/16$ 101 $f_{T13} = f_{CCU6}/32$ 110 $f_{T13} = f_{CCU6}/64$ 111 $f_{T13} = f_{CCU6}/128$
T13PRE	3	rw	Timer T13 Prescaler Bit In order to support higher clock frequencies, an additional prescaler factor of 1/256 can be enabled for the prescaler for T13. 0 The additional prescaler for T13 is disabled. 1 The additional prescaler for T13 is enabled.
T13R¹⁾	4	rh	Timer T13 Run Bit T13R starts and stops timer T13. It is set/reset by software by setting bit T13RR or T13RS, or it is set/reset by hardware according to the function defined by bit T13SSC, and bit fields T13TEC and T13TED. 0 Timer T13 is stopped. 1 Timer T13 is running.
STE13	5	rh	Timer T13 Shadow Transfer Enable Bit STE13 enables or disables the shadow transfer of the T13 period value, the compare value and passive state select bit and level from their shadow registers to the actual registers if a T13 shadow transfer event is detected. Bit STE13 is cleared by hardware after the shadow transfer. A T13 shadow transfer event is a period-match. 0 The shadow register transfer is disabled. 1 The shadow register transfer is enabled.
0	[7:6]	r	Reserved Returns 0 if read; should be written with 0.

¹⁾ A concurrent set/reset action on T13R (from T13SSC, T13TEC, T13RR or T13RS) will have no effect. The bit T12R will remain unchanged.

Capture/Compare Unit 6

Note: A write action to the bit field T12CLK or bit T12PRE is only taken into account when the timer T12 is not running ($T12R = 0$). A write action to the bit field T13CLK or bit T13PRE is only taken into account when the timer T13 is not running ($T13R = 0$).

Capture/Compare Unit 6

Register TCTR2 controls the single-shot and the synchronization functionality of both timers T12 and T13. Both timers can run in single-shot mode. In this mode, they stop their counting sequence automatically after one counting period with a count value of zero. The single-shot mode and the synchronization of T13 to T12 allow the generation of events with a programmable delay after well-defined PWM actions of T12. For example, this feature can be used to trigger AD conversions, after a specified delay (to avoid problems due to switching noise), synchronously to a PWM event.

TCTR2L
Timer Control Register 2 Low
Reset Value: 00_H

7	6	5	4	3	2	1	0
0	T13 TED		T13 TEC		T13 SSC		T12 SSC
r	rw		rw		rw		rw

Field	Bits	Type	Description
T12SSC	0	rw	Timer T12 Single-Shot Control This bit controls the single-shot mode of T12. 0 The single-shot mode is disabled, no hardware action on T12R. 1 The single-shot mode is enabled, the bit T12R is reset by hardware if: <ul style="list-style-type: none"> – T12 reaches its period value in edge-aligned mode – T12 reaches the value 1 while counting down in center-aligned mode. In parallel to the reset action of bit T12R, the bits CC6xST (x = 0 - 2) are reset.
T13SSC	1	rw	Timer T13 Single-Shot Control This bit controls the single-shot mode of T13. 0 No hardware action on T13R 1 The single-shot mode is enabled, the bit T13R is reset by hardware if T13 reaches its period value. In parallel to the reset action of bit T13R, the bit CC63ST is reset.

Field	Bits	Type	Description
T13TEC	[4:2]	rw	T13 Trigger Event Control Bit field T13TEC selects the trigger event to start T13 (automatic set of T13R for synchronization to T12 compare signals) according to following combinations: 000 No action 001 Set T13R on a T12 compare event on channel 0 010 Set T13R on a T12 compare event on channel 1 011 Set T13R on a T12 compare event on channel 2 100 Set T13R on any T12 compare event on channel 0, 1, or 2 101 Set T13R upon a period-match of T12 110 Set T13R upon a zero-match of T12 (while counting up) 111 Set T13R on any edge of inputs CCPOSx
T13TED¹⁾	[6:5]	rw	Timer T13 Trigger Event Direction Bit field T13TED delivers additional information to control the automatic set of bit T13R in case the trigger action defined by T13TEC is detected. 00 Reserved, no action 01 While T12 is counting up 10 While T12 is counting down 11 Independent of the count direction of T12
0	7	r	Reserved Returns 0 if read; should be written with 0.

¹⁾ Example:

If the timer T13 is intended to start at any compare event on T12 (T13TEC = 100_B), the trigger event direction can be programmed to:

- counting up >> a T12 channel 0, 1, 2 compare match triggers T13R only while T12 is counting up
- counting down >> a T12 channel 0, 1, 2 compare match triggers T13R only while T12 is counting down
- independent of bit CDIR >> each T12 channel 0, 1, 2 compare match triggers T13R

The timer count direction is taken from the value of bit CDIR. As a result, if T12 is running in edge-aligned mode (counting up only), T13 can only be started automatically if bit field T13TED = 01_B or 11_B.

Capture/Compare Unit 6

TCTR2H

Timer Control Register 2 High

Reset Value: 00_H

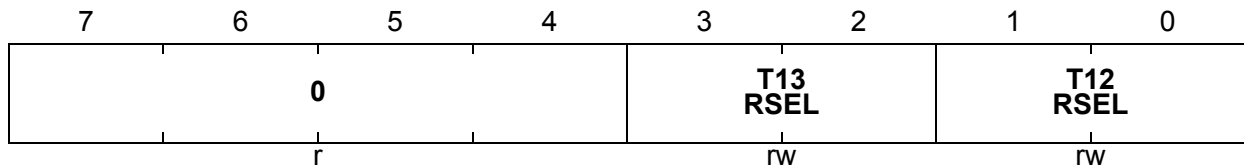

Field	Bits	Type	Description
T12RSEL	[1:0]	rw	<p>Timer T12 External Run Selection Bit field T12RSEL defines the event of signal T12HR that can set the run bit T12R by hardware.</p> <p>00 The external setting of T12R is disabled. 01 Bit T12R is set if a rising edge of signal T12HR is detected. 10 Bit T12R is set if a falling edge of signal T12HR is detected. 11 Bit T12R is set if an edge of signal T12HR is detected.</p>
T13RSEL	[3:2]	rw	<p>Timer T13 External Run Selection Bit field T13RSEL defines the event of signal T13HR that can set the run bit T13R by hardware.</p> <p>00 The external setting of T13R is disabled. 01 Bit T13R is set if a rising edge of signal T13HR is detected. 10 Bit T13R is set if a falling edge of signal T13HR is detected. 11 Bit T13R is set if an edge of signal T13HR is detected.</p>
0	[7:4]	r	<p>Reserved Returns 0 if read; should be written with 0.</p>

Capture/Compare Unit 6

Register TCTR4 allows the software control of the run bits T12R and T13R through independent set and reset conditions. Furthermore, the timers can be reset (while running) and the bits STE12 and STE13 can be controlled by software.

TCTR4L
Timer Control Register 4 Low
Reset Value: 00_H

7	6	5	4	3	2	1	0
T12 STD	T12 STR	0		DT RES	T12 RES	T12 RS	T12 RR
w	w	r		w	w	w	w

Field	Bits	Type	Description
T12RR	0	w	Timer T12 Run Reset Setting this bit resets the T12R bit. 0 T12R is not influenced. 1 T12R is cleared, T12 stops counting
T12RS	1	w	Timer T12 Run Set Setting this bit sets the T12R bit. 0 T12R is not influenced. 1 T12R is set, T12 counts.
T12RES	2	w	Timer T12 Reset 0 No effect on T12 1 The T12 counter register is reset to zero. The switching of the output signals is according to the switching rules. Setting of T12RES has no impact on bit T12R.
DTRES	3	w	Dead-Time Counter Reset 0 No effect on the dead-time counters 1 The three dead-time counter channels are reset to zero.
T12STR	6	w	Timer T12 Shadow Transfer Request 0 No action 1 STE12 is set, enabling the shadow transfer.
T12STD	7	w	Timer T12 Shadow Transfer Disable 0 No action 1 STE12 is reset without triggering the shadow transfer.
0	[5:4]	r	Reserved Returns 0 if read; should be written with 0.

TCTR4H

Timer Control Register 4 High

Reset Value: 00_H

7	6	5	4	3	2	1	0
T13 STD	T13 STR	0			T13 RES	T13 RS	T13 RR
w	w	r			w	w	w

Field	Bits	Type	Description
T13RR	0	w	Timer T13 Run Reset Setting this bit resets the T13R bit. 0 T13R is not influenced. 1 T13R is cleared, T13 stops counting.
T13RS	1	w	Timer T13 Run Set Setting this bit sets the T13R bit. 0 T13R is not influenced. 1 T13R is set, T13 counts.
T13RES	2	w	Timer T13 Reset 0 No effect on T13 1 The T13 counter register is reset to zero. The switching of the output signals is according to the switching rules. Setting of T13RES has no impact on bit T13R.
T13STR	6	w	Timer T13 Shadow Transfer Request 0 No action 1 STE13 is set, enabling the shadow transfer.
T13STD	7	w	Timer T13 Shadow Transfer Disable 0 No action 1 STE13 is reset without triggering the shadow transfer.
0	[5:3]	r	Reserved Returns 0 if read; should be written with 0.

Note: A simultaneous write of a 1 to bits which set and reset the same bit will trigger no action (for example, writing 1 to bits T13RR and T13RS will not modify bit T13R). The corresponding bit will remain unchanged.

12.3.5 Modulation Control Registers

12.3.5.1 Global Module Control

Register MODCTR contains control bits that enable the modulation of the corresponding output signal by PWM pattern generated by the timers T12 and T13. Furthermore, the multi-channel mode can be enabled as additional modulation source for the output signals.

MODCTRL

Modulation Control Register Low

Reset Value: 00_H

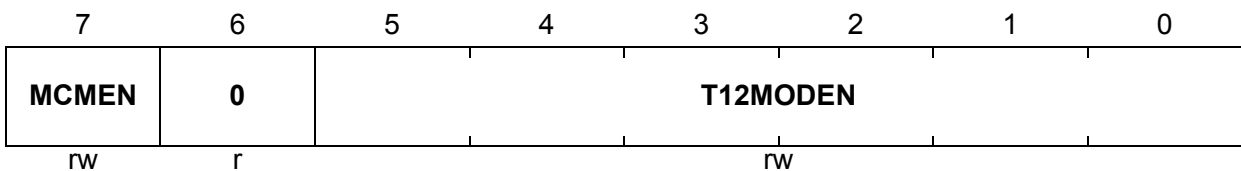

Field	Bits	Type	Description
T12MODEN	[5:0]	rw	<p>T12 Modulation Enable</p> <p>Setting these bits enables the modulation of the corresponding compare channel by a PWM pattern generated by timer T12. The bit positions correspond to the following output signals:</p> <ul style="list-style-type: none"> Bit 0 Modulation of CC60 Bit 1 Modulation of COUT60 Bit 2 Modulation of CC61 Bit 3 Modulation of COUT61 Bit 4 Modulation of CC62 Bit 5 Modulation of COUT62 <p>The enable feature of the modulation is defined as follows:</p> <ul style="list-style-type: none"> 0 The modulation of the corresponding output signal by a T12 PWM pattern is disabled. 1 The modulation of the corresponding output signal by a T12 PWM pattern is enabled.

Capture/Compare Unit 6

Field	Bits	Type	Description
MCMEN	7	rw	Multi-Channel Mode Enable 0 The modulation of the corresponding output signal by a multi-channel pattern according to bit field MCMP is disabled. 1 The modulation of the corresponding output signal by a multi-channel pattern according to bit field MCMP is enabled.
0	6	r	Reserved Returns 0 if read; should be written with 0.

MODCTRH

Modulation Control Register High

Reset Value: 00_H

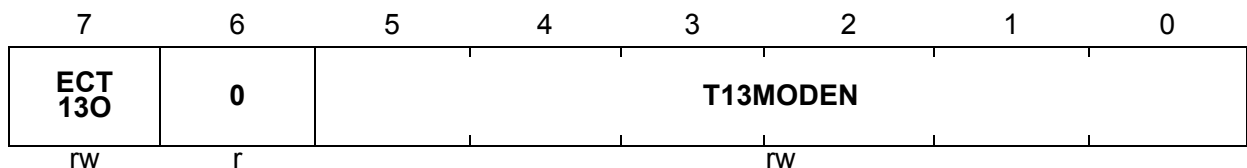

Field	Bits	Type	Description
T13MODEN	[5:0]	rw	T13 Modulation Enable Setting these bits enables the modulation of the corresponding compare channel by a PWM pattern generated by timer T13. The bit positions correspond to the following output signals: Bit 0 Modulation of CC60 Bit 1 Modulation of COUT60 Bit 2 Modulation of CC61 Bit 3 Modulation of COUT61 Bit 4 Modulation of CC62 Bit 5 Modulation of COUT62 The enable feature of the modulation is defined as follows: 0 The modulation of the corresponding output signal by a T13 PWM pattern is disabled. 1 The modulation of the corresponding output signal by a T13 PWM pattern is enabled.

Capture/Compare Unit 6

Field	Bits	Type	Description
ECT130	7	rw	<p>Enable Compare Timer T13 Output</p> <p>0 The alternate output function COUT63 is disabled.</p> <p>1 The alternate output function COUT63 is enabled for the PWM signal generated by T13.</p>
0	6	r	<p>Reserved</p> <p>Returns 0 if read; should be written with 0.</p>

Capture/Compare Unit 6

Register TRPCTR controls the trap functionality. It contains independent enable bits for each output signal and control bits to select the behavior in case of a trap condition. The trap condition is a low level on the CTRAP input pin, which is monitored (inverted level) by bit TRPF (in register IS). While TRPF = 1 (trap input active), the trap state bit TRPS (in register IS) is set to 1.

TRPCTRL

Trap Control Register Low

Reset Value: 00_H

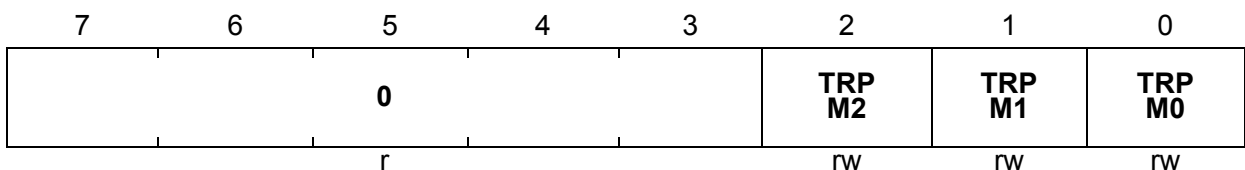

Field	Bits	Type	Description
TRPM0, TRPM1	[1:0]	rw	<p>Trap Mode Control Bits 0, 1</p> <p>These two bits define the behavior of the selected outputs when leaving the trap state after the trap condition has become inactive again. A synchronization to the timer driving the PWM pattern avoids unintended short pulses when leaving the trap state. The combination (TRPM0 and TRPM1) leads to:</p> <p>00 The trap state is left (return to normal operation according to TRPM2) when a zero-match of T12 (while counting up) is detected (synchronization to T12).</p> <p>01 The trap state is left (return to normal operation according to TRPM2) when a zero-match of T13 is detected (synchronization to T13).</p> <p>10 Reserved</p> <p>11 The trap state is left (return to normal operation according to TRPM2) immediately without any synchronization to T12 or T13.</p>

Capture/Compare Unit 6

Field	Bits	Type	Description
TRPM2	2	rw	<p>Trap Mode Control Bit 2</p> <p>0 The trap state can be left (return to normal operation = bit TRPS = 0) as soon as the input <u>CTRAP</u> becomes inactive. Bit TRPF is <u>automatically</u> cleared by hardware if the input pin <u>CTRAP</u> becomes 1. Bit TRPS is automatically cleared by hardware if bit TRPF is 0 and if the synchronization condition (according to TRPM0 and TRPM1) is detected.</p> <p>1 The trap state can be left (return to normal operation = bit TRPS = 0) as soon as <u>bit TRPF</u> is reset by software after the input <u>CTRAP</u> becomes inactive (TRPF is not cleared by hardware). Bit TRPS is automatically cleared by hardware if bit TRPF = 0 and if the synchronization condition (according to TRPM0 and TRPM1) is detected.</p>
0	[7:3]	r	<p>Reserved</p> <p>Returns 0 if read; should be written with 0.</p>

TRPCTRH

Trap Control Register High

Reset Value: 00_H

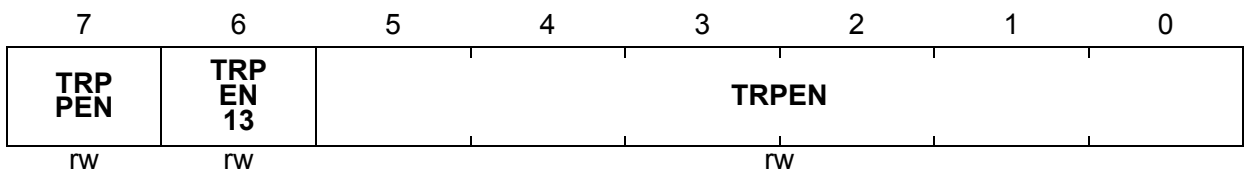

Field	Bits	Type	Description
TRPEN	[5:0]	rw	<p>Trap Enable Control</p> <p>Setting these bits enables the trap functionality for the following corresponding output signals:</p> <ul style="list-style-type: none"> Bit 0 Trap functionality of CC60 Bit 1 Trap functionality of COUT60 Bit 2 Trap functionality of CC61 Bit 3 Trap functionality of COUT61 Bit 4 Trap functionality of CC62 Bit 5 Trap functionality of COUT62 <p>The enable feature of the trap functionality is defined as follows:</p> <ul style="list-style-type: none"> 0 The trap functionality of the corresponding output signal is disabled. The output state is independent of bit TRPS. 1 The trap functionality of the corresponding output signal is enabled. The output is set to the passive state while TRPS = 1.
TRPEN13	6	rw	<p>Trap Enable Control for Timer T13</p> <ul style="list-style-type: none"> 0 The trap functionality for T13 is disabled. Timer T13 (if selected and enabled) provides PWM functionality even while TRPS = 1. 1 The trap functionality for T13 is enabled. The timer T13 PWM output signal is set to the passive state while TRPS = 1.
TRPPEN	7	rw	<p>Trap Pin Enable</p> <ul style="list-style-type: none"> 0 <u>The trap</u> functionality based on the input pin CTRAP is disabled. A trap can only be generated by software by setting bit TRPF. 1 <u>The trap</u> functionality based on the input pin CTRAP is enabled. A trap can be <u>generated</u> by software by setting bit TRPF or by CTRAP = 0.

Capture/Compare Unit 6

Register PSLR defines the passive state level driven by the output pins of the module. The passive state level is the value that is driven by the port pin during the passive state of the output. During the active state, the corresponding output pin drives the active state level, which is the inverted passive state level. The passive state level permits the adaptation of the driven output levels to the driver polarity (inverted or not inverted) of the connected power stage.

PSLR

Passive State Level Register

Reset Value: 00_H

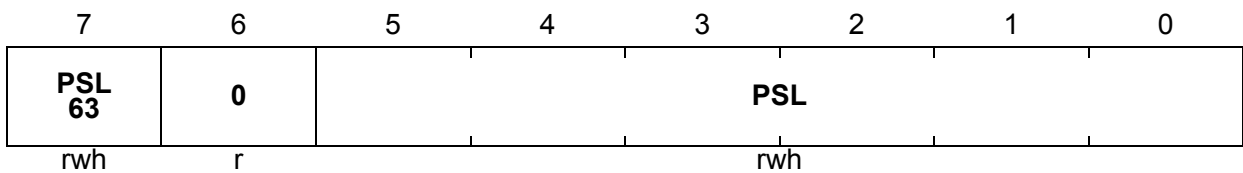

Field	Bits	Type	Description
PSL¹⁾	[5:0]	rwh	<p>Compare Outputs Passive State Level</p> <p>The bits of this bit field define the passive level driven by the module outputs during the passive state. The bit positions are:</p> <p>Bit 0 Passive level for output CC60 Bit 1 Passive level for output COUT60 Bit 2 Passive level for output CC61 Bit 3 Passive level for output COUT61 Bit 4 Passive level for output CC62 Bit 5 Passive level for output COUT62</p> <p>The value of each bit position is defined as:</p> <p>0 The passive level is 0. 1 The passive level is 1.</p>
PSL63²⁾	7	rwh	<p>Passive State Level of Output COUT63</p> <p>This bit field defines the passive level of the output pin COUT63.</p> <p>0 The passive level is 0. 1 The passive level is 1.</p>
0	6	r	<p>Reserved</p> <p>Returns 0 if read; should be written with 0.</p>

¹⁾ Bit field PSL has a shadow register to allow for updates without undesired pulses on the output lines. The bits are updated with the T12 shadow transfer. A read action targets the actually used values, while a write action targets the shadow bits.

Capture/Compare Unit 6

- 2) Bit PSL63 has a shadow register to allow for updates without undesired pulses on the output line. The bit is updated with the T13 shadow transfer. A read action targets the actually used values, while a write action targets the shadow bits.

12.3.5.2 Multi-Channel Control

Register MCMOUTS contains bits that control the output states for multi-channel mode. Furthermore, the appropriate signals for the block commutation by Hall sensors can be selected. This register is a shadow register (that can be written) for register MCMOUT, which indicates the currently active signals.

MCMOUTSL

Multi-Channel Mode Output Shadow Register Low

Reset Value: 00_H

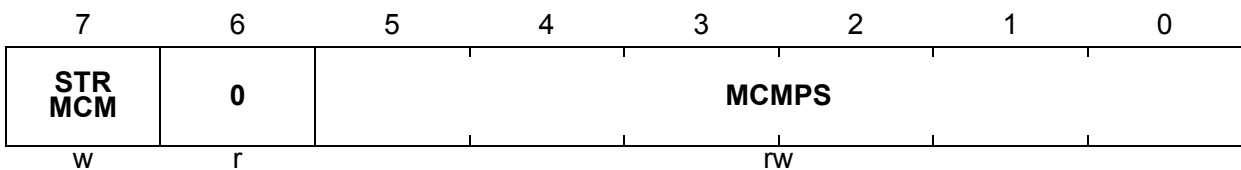

Field	Bits	Type	Description
MCMPS	[5:0]	rw	Multi-Channel PWM Pattern Shadow Bit field MCMPS is the shadow bit field for bit field MCMP. The multi-channel shadow transfer is triggered according to the transfer conditions defined by register MCMCTR.
STRMCM	7	w	Shadow Transfer Request for MCMPS Setting this bit during a write action leads to an immediate update of bit field MCMP by the value written to bit field MCMPS. This functionality permits an update triggered by software. When read, this bit always delivers 0. 0 Bit field MCMP is updated according to the defined hardware action. The write access to bit field MCMPS does not modify bit field MCMP. 1 Bit field MCMP is updated by the value written to bit field MCMPS.
0	6	r	Reserved Returns 0 if read; should be written with 0.

Capture/Compare Unit 6

MCMOUTSH

Multi-Channel Mode Output Shadow Register High

Reset Value: 00_H

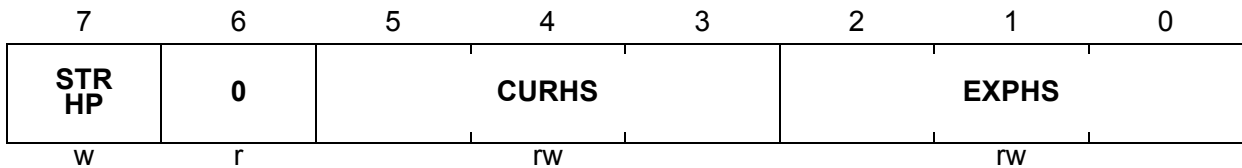

Field	Bits	Type	Description
EXPHS	[2:0]	rw	Expected Hall Pattern Shadow Bit field EXPHS is the shadow bit field for bit field EXPH. The bit field is transferred to bit field EXPH if an edge on the hall input pins CCPOSx (x = 0 - 2) is detected.
CURHS	[5:3]	rw	Current Hall Pattern Shadow Bit field CURHS is the shadow bit field for bit field CURH. The bit field is transferred to bit field CURH if an edge on the hall input pins CCPOSx (x = 0 - 2) is detected.
STRHP	7	w	Shadow Transfer Request for the Hall Pattern Setting these bits during a write action leads to an immediate update of bit fields CURH and EXPH by the value written to bit fields CURHS and EXPHS. This functionality permits an update triggered by software. When read, this bit always delivers 0. 0 The bit fields CURH and EXPH are updated according to the defined hardware action. The write access to bit fields CURHS and EXPHS does not modify the bit fields CURH and EXPH. 1 The bit fields CURH and EXPH are updated by the value written to the bit fields CURHS and EXPHS.
0	6	r	Reserved Returns 0 if read; should be written with 0.

Capture/Compare Unit 6

Register MCMOUT specifies the multi-channel control bits that are currently used.

MCMOUTL

Multi-Channel Mode Output Register Low

Reset Value: 00_H

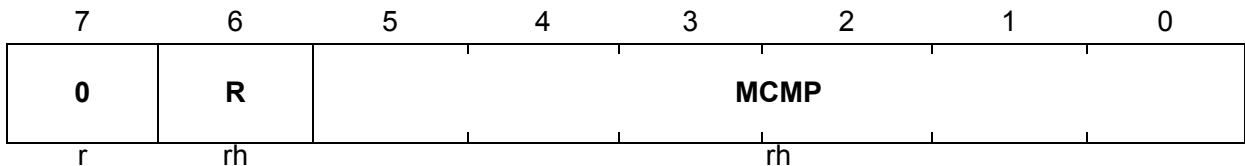

Field	Bits	Type	Description
MCMP¹⁾	[5:0]	rh	<p>Multi-Channel PWM Pattern</p> <p>Bit field MCMP is written by a shadow transfer from bit field MCMPS. It contains the output pattern for the multi-channel mode. If this mode is enabled by bit MCMEN in register MODCTR, the output state of the following output signal can be modified:</p> <p>Bit 0 Multi-channel state for output CC60 Bit 1 Multi-channel state for output COUT60 Bit 2 Multi-channel state for output CC61 Bit 3 Multi-channel state for output COUT61 Bit 4 Multi-channel state for output CC62 Bit 5 Multi-channel state for output COUT62</p> <p>The multi-channel patterns can set the related output to the passive state.</p> <p>0 The output is set to the passive state. The PWM generated by T12 or T13 is not taken into account.</p> <p>1 The output can deliver the PWM generated by T12 or T13 (according to register MODCTR).</p>

Capture/Compare Unit 6

Field	Bits	Type	Description
R	6	rh	<p>Reminder Flag</p> <p>This reminder flag indicates that the shadow transfer from bit field MCMPS to MCMP has been requested by the selected trigger source. This bit is cleared when the shadow transfer takes place and while MCMEN = 0.</p> <p>0 No shadow transfer from MCMPS to MCMP is requested</p> <p>1 A shadow transfer from MCMPS to MCMP has been requested by the selected trigger source, but has not been executed, because the selected synchronization condition has not occurred.</p>
0	7	r	<p>Reserved</p> <p>Returns 0 if read; should be written with 0.</p>

1) While IDLE = 1, bit field MCMP is cleared.

MCMOUTH

Multi-Channel Mode Output Register High

Reset Value: 00_H

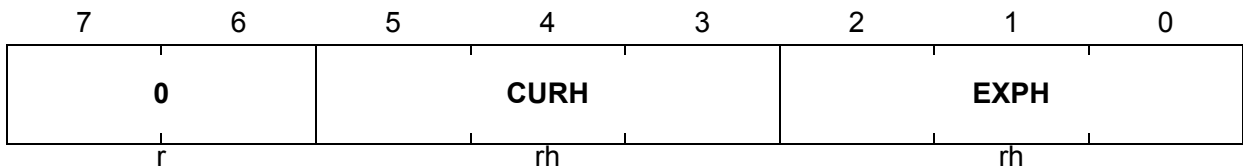

Field	Bits	Type	Description
EXPH ¹⁾	[2:0]	rh	<p>Expected Hall Pattern</p> <p>Bit field EXPH is written by a shadow transfer from bit field EXPHS. The contents are compared after every detected edge at the hall input pins in order to detect the occurrence of the next desired (expected) hall pattern or a wrong pattern.</p> <p>If the current hall pattern at the hall input pins is equal to the bit field EXPH, bit CHE (correct hall event) is set and an interrupt request is generated (if enabled by bit ENCHE).</p> <p>If the current hall pattern at the hall input pins is not equal to the bit fields CURH or EXPH, bit WHE (wrong hall event) is set and an interrupt request is generated (if enabled by bit ENWHE).</p>
CURH	[5:3]	rh	<p>Current Hall Pattern</p> <p>Bit field CURH is written by a shadow transfer from bit field CURHS. The contents are compared after every detected edge at the hall input pins in order to detect the occurrence of the next desired (expected) hall pattern or a wrong pattern.</p> <p>If the current Hall input pattern is equal to bit field CURH, the detected edge at the hall input pins was an invalid transition (e.g., a spike).</p>
0	[7:6]	r	<p>Reserved</p> <p>Returns 0 if read; should be written with 0.</p>

¹⁾ The bits in the bit fields EXPH and CURH correspond to the hall patterns at the input pins CCPOS_x (x = 0 - 2) in the following order (EXPH.2, EXPH.1, EXPH.0), (CURH.2, CURH.1, CURH.0), (CCPOS2, CCPOS1, CCPOS0).

Capture/Compare Unit 6

Register MCMCTR contains control bits for the multi-channel functionality.

MCMCTR

Multi-Channel Mode Control Register

Reset Value: 00_H

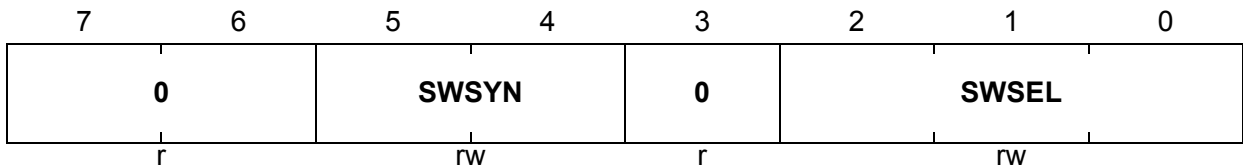

Field	Bits	Type	Description
SWSEL	[2:0]	rw	<p>Switching Selection Bit field SWSEL selects one of the following trigger request sources (next multi-channel event) for the shadow transfer from MCMPS to MCMP. The trigger request is stored in the reminder flag R until the shadow transfer is done and flag R is cleared automatically with the shadow transfer. The shadow transfer takes place synchronously with an event selected in bit field SWSYN.</p> <p>000 No trigger request will be generated 001 Correct hall pattern on CCPOSx detected 010 T13 period-match detected (while counting up) 011 T12 one-match (while counting down) 100 T12 channel 1 compare-match detected (phase delay function) 101 T12 period match detected (while counting up); else reserved, no trigger request will be generated</p>

Capture/Compare Unit 6

Field	Bits	Type	Description
SWSYN	[5:4]	rw	<p>Switching Synchronization Bit field SWSYN triggers the shadow transfer between MCMPS and MCMP if it has been requested before (flag R set by an event selected by SWSEL). This feature permits the synchronization of the outputs to the PWM source that is used for modulation (T12 or T13).</p> <p>00 Direct; the trigger event directly causes the shadow transfer</p> <p>01 T13 zero-match triggers the shadow transfer</p> <p>10 A T12 zero-match (while counting up) triggers the shadow transfer</p> <p>11 Reserved; no action</p>
0	3, [7:6]	r	<p>Reserved Returns 0 if read; should be written with 0.</p>

Note: The generation of the shadow transfer request by hardware is only enabled if bit MCMEN = 1.

Capture/Compare Unit 6

Register T12MSEL contains control bits that select the capture/compare functionality of the three channels of timer T12.

T12MSELL

T12 Capture/Compare Mode Select Register Low

Reset Value: 00_H

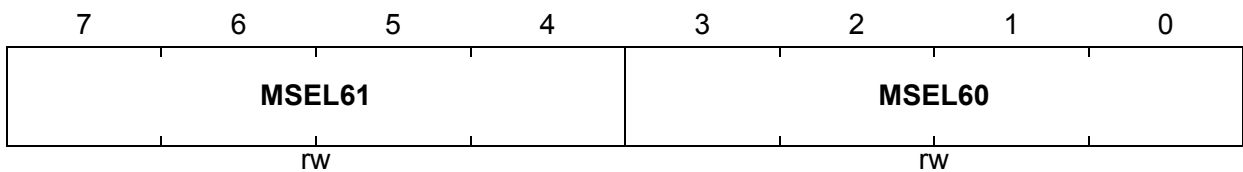

Field	Bits	Type	Description
MSEL60, MSEL61	[3:0], [7:4]	rw	<p>Capture/Compare Mode Selection</p> <p>These bit fields select the operating mode of the three timer T12 capture/compare channels. Each channel (n = 0 - 2) can be programmed individually either for compare or capture operation according to:</p> <p>0000 Compare outputs disabled, pins CC6n and COUT6n can be used for I/O pins. No capture action.</p> <p>0001 Compare output on pin CC6n, pin COUT6n can be used for I/O pins. No capture action.</p> <p>0010 Compare output on pin COUT6n, pin CC6n can be used for I/O pins. No capture action.</p> <p>0011 Compare output on pins COUT6n and CC6n</p> <p>01XX Double-register capture modes, see Table 12-5.</p> <p>1000 Hall sensor mode, see Table 12-6. In order to enable the hall edge detection, MSEL6x (x = 0 - 2) must be programmed to hall sensor mode.</p> <p>1001 Hysteresis-like mode, see Table 12-6</p> <p>101X Multi-input capture modes, see Table 12-7</p> <p>11XX Multi-input capture modes, see Table 12-7</p>

Capture/Compare Unit 6

T12MSELH

T12 Capture/Compare Mode Select Register High

Reset Value: 00_H

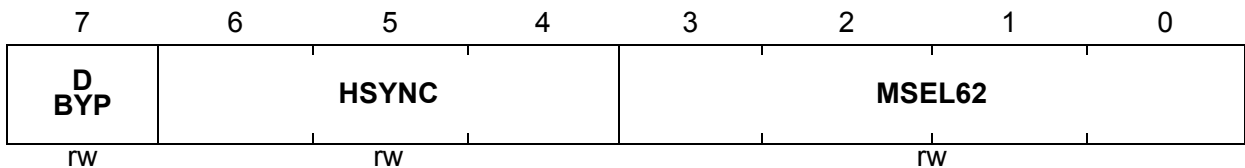

Field	Bits	Type	Description
MSEL62	[3:0]	rw	<p>Capture/Compare Mode Selection</p> <p>These bit fields select the operating mode of the three timer T12 capture/compare channels. Each channel (n = 0 - 2) can be programmed individually either for compare or capture operation according to:</p> <p>0000 Compare outputs disabled, pins CC6n and COUT6n can be used for I/O pins. No capture action.</p> <p>0001 Compare output on pin CC6n, pin COUT6n can be used for I/O pins. No capture action.</p> <p>0010 Compare output on pin COUT6n, pin CC6n can be used for I/O pins. No capture action.</p> <p>0011 Compare output on pins COUT6n and CC6n.</p> <p>01XX Double-register capture modes, see Table 12-5.</p> <p>1000 Hall sensor mode, see Table 12-6. In order to enable the hall edge detection, all three MSEL6x must be programmed to hall sensor mode.</p> <p>1001 Hysteresis-like mode, see Table 12-6.</p> <p>101X Multi-input capture modes, see Table 12-7.</p> <p>11XX Multi-input capture modes, see Table 12-7.</p>

Field	Bits	Type	Description
HSYNC	[6:4]	rw	<p>Hall Synchronization</p> <p>Bit field HSYNC defines the source for the sampling of the Hall input pattern and the comparison to the current and the expected Hall pattern bit fields. In all modes, a trigger by software by writing a 1 to bit SWHC is possible.</p> <p>000 Any edge at one of the inputs CCPOSx (x = 0 - 2) triggers the sampling.</p> <p>001 A T13 compare-match triggers the sampling.</p> <p>010 A T13 period-match triggers the sampling.</p> <p>011 The Hall sampling triggered by hardware sources is switched off.</p> <p>100 A T12 period-match (while counting up) triggers the sampling.</p> <p>101 A T12 one-match (while counting down) triggers the sampling.</p> <p>110 A T12 compare-match of channel 0 (while counting up) triggers the sampling.</p> <p>111 A T12 compare-match of channel 0 (while counting down) triggers the sampling.</p>
DBYP	7	rw	<p>Delay Bypass</p> <p>Bit DBYP determines if the source signal for the sampling of the Hall input pattern (selected by HSYNC) uses the dead-time counter DTC0 of timer T12 as additional delay or if the delay is bypassed.</p> <p>0 The delay bypass is not active. The dead-time counter DTC0 generates a delay after the source signal becomes active.</p> <p>1 The delay bypass is active. The dead-time counter DTC0 is not used by the sampling of the Hall pattern.</p>

Note: In the capture modes, all edges at the CC6x inputs lead to the setting of the corresponding interrupt status flags in register IS. In order to monitor the selected capture events at the CCPOSx inputs in the multi-input capture modes, the CC6xST bits of the corresponding channel are set when detecting the selected event. The interrupt status bits and the CC6xST bits must be reset by software.

Table 12-5 Double-Register Compare Modes

Description	
Double-Register Capture Modes	
0100	The contents of T12 are stored in CC6nR after a rising edge and in CC6nSR after a falling edge on the input pin CC6n.
0101	The value stored in CC6nSR is copied to CC6nR after a rising edge on the input pin CC6n. The actual timer value of T12 is simultaneously stored in the shadow register CC6nSR. This feature is useful for time measurements between consecutive rising edges on pins CC6n. COUT6n is I/O pin.
0110	The value stored in CC6nSR is copied to CC6nR after a falling edge on the input pin CC6n. The actual timer value of T12 is simultaneously stored in the shadow register CC6nSR. This feature is useful for time measurements between consecutive falling edges on pins CC6n. COUT6n is I/O pin.
0111	The value stored in CC6nSR is copied to CC6nR after any edge on the input pin CC6n. The actual timer value of T12 is simultaneously stored in the shadow register CC6nSR. This feature is useful for time measurements between consecutive edges on pins CC6n. COUT6n is I/O pin.

Table 12-6 Combined T12 Modes

Description	
Combined T12 Modes	
1000	Hall sensor mode: Capture mode for channel 0, compare mode for channels 1 and 2. The contents of T12 are captured into CC60 at a valid hall event (which is a reference to the actual speed). CC61 can be used for a phase delay function between hall event and output switching. CC62 can act as a time-out trigger if the expected hall event is too late. The value 1000 _B must be programmed to MSEL0, MSEL1 and MSEL2 if the hall signals are used. In this mode, the contents of timer T12 are captured in CC60 and T12 is reset after the detection of a valid hall event. In order to avoid noise effects, the dead-time counter channel 0 is started after an edge has been detected at the hall inputs. On reaching the value of 000001 _B , the hall inputs are sampled and the pattern comparison is done.
1001	Hysteresis-like control mode with dead-time generation: The negative edge of the CCPOSx input signal is used to reset bit CC6nST. As a result, the output signals can be switched to passive state immediately and switched back to active state (with dead-time) if the CCPOSx is high and the bit CC6nST is set by a compare event.

Table 12-7 Multi-Input Capture Modes

Description	
Multi-Input Capture Modes	
1010	The timer value of T12 is stored in CC6nR after a rising edge at the input pin CC6n. The timer value of T12 is stored in CC6nSR after a falling edge at the input pin CCPOSx.
1011	The timer value of T12 is stored in CC6nR after a falling edge at the input pin CC6n. The timer value of T12 is stored in CC6nSR after a rising edge at the input pin CCPOSx.
1100	The timer value of T12 is stored in CC6nR after a rising edge at the input pin CC6n. The timer value of T12 is stored in CC6nSR after a rising edge at the input pin CCPOSx.
1101	The timer value of T12 is stored in CC6nR after a falling edge at the input pin CC6n. The timer value of T12 is stored in CC6nSR after a falling edge at the input pin CCPOSx.
1110	The timer value of T12 is stored in CC6nR after any edge at the input pin CC6n. The timer value of T12 is stored in CC6nSR after any edge at the input pin CCPOSx.
1111	Reserved (no capture or compare action)

12.3.6 Interrupt Control Registers

ISL

Capture/Compare Interrupt Status Register Low

Reset Value: 00_H

7	6	5	4	3	2	1	0
T12 PM	T12 OM	ICC 62F	ICC 62R	ICC 61F	ICC 61R	ICC 60F	ICC 60R
rh	rh	rh	rh	rh	rh	rh	rh

Field	Bits	Type	Description
ICC60R, ICC61R, ICC62R	0, 2, 4	rh	<p>Capture, Compare-Match Rising Edge Flag In compare mode, a compare-match has been detected while T12 was counting up. In capture mode, a rising edge has been detected at the input CC6x (x = 0 - 2).</p> <p>0 The event has not occurred since this bit was reset. 1 The event described above has been detected.</p>
ICC60F, ICC61F, ICC62F	1, 3, 5	rh	<p>Capture, Compare-Match Falling Edge Flag In compare mode, a compare-match has been detected while T12 was counting down. In capture mode, a falling edge has been detected at the input CC6x (x = 0 - 2).</p> <p>0 The event has not occurred since this bit was reset. 1 The event described above has been detected.</p>
T12OM	6	rh	<p>Timer T12 One-Match Flag 0 A timer T12 one-match (while counting down) has not been detected since this bit was reset. 1 A timer T12 one-match (while counting down) has been detected.</p>
T12PM	7	rh	<p>Timer T12 Period-Match Flag 0 A timer T12 period-match (while counting up) has not been detected since this bit was reset. 1 A timer T12 period-match (while counting up) has been detected.</p>

Capture/Compare Unit 6

ISH

Capture/Compare Interrupt Status Register High

Reset Value: 00_H

7	6	5	4	3	2	1	0
STR	IDLE	WHE	CHE	TRP S	TRP F	T13 PM	T13 CM
rh	rh	rh	rh	rh	rh	rh	rh

Field	Bits	Type	Description
T13CM	0	rh	Timer T13 Compare-Match Flag 0 A timer T13 compare-match has not been detected since this bit was reset. 1 A timer T13 compare-match has been detected.
T13PM	1	rh	Timer T13 Period-Match Flag 0 A timer T13 period-match has not been detected since this bit was reset. 1 A timer T13 period-match has been detected.
TRPF	2	rh	Trap Flag The trap flag TRPF will be set by hardware if TRPPEN = 1 and CTRAP = 0 or by software. If TRPM2 = 0, bit TRPF is reset by hardware if the input CTRAP becomes inactive (TRPPEN = 1). If TRPM2 = 1, bit TRPF must be reset by software in order to leave the trap state. 0 The trap condition has not been detected. 1 The trap condition has been detected (input CTRAP has been 0 or by software).
TRPS¹⁾	3	rh	Trap State 0 The trap state is not active. 1 The trap state is active. Bit TRPS is set while bit TRPF = 1. It is reset according to the mode selected in register TRPCTR.
CHE²⁾	4	rh	Correct Hall Event 0 A transition to a correct (expected) hall event has not been detected since this bit was reset. 1 A transition to a correct (expected) hall event has been detected.

Capture/Compare Unit 6

Field	Bits	Type	Description
WHE ³⁾	5	rh	Wrong Hall Event 0 A transition to a wrong hall event (not the expected one) has not been detected since this bit was reset. 1 A transition to a wrong hall event (not the expected one) has been detected.
IDLE ⁴⁾	6	rh	IDLE State This bit is set together with bit WHE (wrong hall event) and it must be reset by software. 0 No action 1 Bit field MCMP is cleared, the selected outputs are set to passive state.
STR	7	rh	Multi-Channel Mode Shadow Transfer Request This bit is set when a shadow transfer from MCMOUTS to MCMOUT takes places in multi-channel mode. 0 The shadow transfer has not taken place. 1 The shadow transfer has taken place.

- 1) During the trap state, the selected outputs are set to the passive state. The logic level driven during the passive state is defined by the corresponding bit in register PSLR. Bit TRPS = 1 and TRPF = 0 can occur if the trap condition is no longer active but the selected synchronization has not yet taken place.
- 2) On every valid hall edge, the contents of EXPH are compared with the pattern on pin CCPOSx and if both are equal, bit CHE is set.
- 3) On every valid hall edge, the contents of EXPH are compared with the pattern on pin CCPOSx. If both comparisons (CURH and EXPH with CCPOSx) are not true, bit WHE (wrong hall event) is set.
- 4) Bit field MCMP is held to 0 by hardware as long as IDLE = 1.

Note: Not all bits in register IS can generate an interrupt. Other status bits have been added, which have a similar structure for their set and reset actions.

Note: The interrupt generation is independent of the value of the bits in register IS, e.g., the interrupt will be generated (if enabled) even if the corresponding bit is already set. The trigger for an interrupt generation is the detection of a set condition (by hardware or software) for the corresponding bit in register IS.

Note: In compare mode (and hall mode), the timer-related interrupts are only generated while the timer is running (TxR = 1). In capture mode, the capture interrupts are also generated when the timer T12 is stopped.

Capture/Compare Unit 6

ISSL

Capture/Compare Interrupt Status Set Register Low

Reset Value: 00_H

7	6	5	4	3	2	1	0
S T12 PM	S T12 OM	S CC 62F	S CC 62R	S CC 61F	S CC 61R	S CC 60F	S CC 60R
W	W	W	W	W	W	W	W

Field	Bits	Type	Description
SCC60R	0	w	Set Capture, Compare-Match Rising Edge Flag 0 No action 1 Bit ICC60R in register IS will be set.
SCC60F	1	w	Set Capture, Compare-Match Falling Edge Flag 0 No action 1 Bit ICC60F in register IS will be set.
SCC61R	2	w	Set Capture, Compare-Match Rising Edge Flag 0 No action 1 Bit ICC61R in register IS will be set.
SCC61F	3	w	Set Capture, Compare-Match Falling Edge Flag 0 No action 1 Bit ICC61F in register IS will be set.
SCC62R	4	w	Set Capture, Compare-Match Rising Edge Flag 0 No action 1 Bit ICC62R in register IS will be set.
SCC62F	5	w	Set Capture, Compare-Match Falling Edge Flag 0 No action 1 Bit ICC62F in register IS will be set.
ST12OM	6	w	Set Timer T12 One-Match Flag 0 No action 1 Bit T12OM in register IS will be set.
ST12PM	7	w	Set Timer T12 Period-Match Flag 0 No action 1 Bit T12PM in register IS will be set.

Note: If the setting by hardware of the corresponding flags leads to an interrupt, the setting by software has the same effect.

Capture/Compare Unit 6

ISSH

Capture/Compare Interrupt Status Set Register High

Reset Value: 00_H

7	6	5	4	3	2	1	0
S STR	S IDLE	S WHE	S CHE	S WHC	S TRPF	S T13 PM	S T13 CM
W	W	W	W	W	W	W	W

Field	Bits	Type	Description
ST13CM	0	w	Set Timer T13 Compare-Match Flag 0 No action 1 Bit T13CM in register IS will be set.
ST13PM	1	w	Set Timer T13 Period-Match Flag 0 No action 1 Bit T13PM in register IS will be set.
STRPF	2	w	Set Trap Flag 0 No action 1 Bits TRPF and TRPS in register IS will be set.
SWHC	3	w	Software Hall Compare 0 No action 1 The Hall compare action is triggered.
SCHE	4	w	Set Correct Hall Event Flag 0 No action 1 Bit CHE in register IS will be set.
SWHE	5	w	Set Wrong Hall Event Flag 0 No action 1 Bit WHE in register IS will be set.
SIDLE	6	w	Set IDLE Flag 0 No action 1 Bit IDLE in register IS will be set.
SSTR	7	w	Set STR Flag 0 No action 1 Bit STR in register IS will be set.

Capture/Compare Unit 6

Register ISR contains the individual interrupt request reset bits to reset the corresponding flags by software.

ISRL

Capture/Compare Interrupt Status Reset Register Low

Reset Value: 00_H

7	6	5	4	3	2	1	0
R T12 PM	R T12 OM	R CC 62F	R CC 62R	R CC 61F	R CC 61R	R CC 60F	R CC 60R
w	w	w	w	w	w	w	w

Field	Bits	Type	Description
RCC60R	0	w	Reset Capture, Compare-Match Rising Edge Flag 0 No action 1 Bit ICC60R in register IS will be reset.
RCC60F	1	w	Reset Capture, Compare-Match Falling Edge Flag 0 No action 1 Bit ICC60F in register IS will be reset.
RCC61R	2	w	Reset Capture, Compare-Match Rising Edge Flag 0 No action 1 Bit ICC61R in register IS will be reset.
RCC61F	3	w	Reset Capture, Compare-Match Falling Edge Flag 0 No action 1 Bit ICC61F in register IS will be reset.
RCC62R	4	w	Reset Capture, Compare-Match Rising Edge Flag 0 No action 1 Bit ICC62R in register IS will be reset.
RCC62F	5	w	Reset Capture, Compare-Match Falling Edge Flag 0 No action 1 Bit ICC62F in register IS will be reset.
RT12OM	6	w	Reset Timer T12 One-Match Flag 0 No action 1 Bit T12OM in register IS will be reset.
RT12PM	7	w	Reset Timer T12 Period-Match Flag 0 No action 1 Bit T12PM in register IS will be reset.

Capture/Compare Unit 6

ISRH

Capture/Compare Interrupt Status Reset Register High

Reset Value: 00_H

7	6	5	4	3	2	1	0
R STR	R IDLE	R WHE	R CHE	0	R TRPF	R T13 PM	R T13 CM
w	w	w	w	r	w	w	w

Field	Bits	Type	Description
RT13CM	0	w	Reset Timer T13 Compare-Match Flag 0 No action 1 Bit T13CM in register IS will be reset.
RT13PM	1	w	Reset Timer T13 Period-Match Flag 0 No action 1 Bit T13PM in register IS will be reset.
RTRPF	2	w	Reset Trap Flag 0 No action 1 Bit TRPF in register IS will be reset (not taken into account while input $\overline{\text{CTRAP}} = 0$ and TRPPEN = 1).
RCHE	4	w	Reset Correct Hall Event Flag 0 No action 1 Bit CHE in register IS will be reset.
RWHE	5	w	Reset Wrong Hall Event Flag 0 No action 1 Bit WHE in register IS will be reset.
RIDLE	6	w	Reset IDLE Flag 0 No action 1 Bit IDLE in register IS will be reset.
RSTR	7	w	Reset STR Flag 0 No action 1 Bit STR in register IS will be reset.
0	3	r	Reserved Returns 0 if read; should be written with 0.

Capture/Compare Unit 6

IENL

Capture/Compare Interrupt Enable Register Low

Reset Value: 00_H

7	6	5	4	3	2	1	0
EN T12 PM	EN T12 OM	EN CC 62F	EN CC 62R	EN CC 61F	EN CC 61R	EN CC 60F	EN CC 60R
rw	rw	rw	rw	rw	rw	rw	rw

Field	Bits	Type	Description
ENCC60R	0	rw	<p>Capture, Compare-Match Rising Edge Interrupt Enable for Channel 0</p> <p>0 No interrupt will be generated if the set condition for bit ICC60R in register IS occurs.</p> <p>1 An interrupt will be generated if the set condition for bit ICC60R in register IS occurs. The interrupt line that will be activated is selected by bit field INPCC60.</p>
ENCC60F	1	rw	<p>Capture, Compare-Match Falling Edge Interrupt Enable for Channel 0</p> <p>0 No interrupt will be generated if the set condition for bit ICC60F in register IS occurs.</p> <p>1 An interrupt will be generated if the set condition for bit ICC60F in register IS occurs. The interrupt line that will be activated is selected by bit field INPCC60.</p>
ENCC61R	2	rw	<p>Capture, Compare-Match Rising Edge Interrupt Enable for Channel 1</p> <p>0 No interrupt will be generated if the set condition for bit ICC61R in register IS occurs.</p> <p>1 An interrupt will be generated if the set condition for bit ICC61R in register IS occurs. The interrupt line that will be activated is selected by bit field INPCC61.</p>
ENCC61F	3	rw	<p>Capture, Compare-Match Falling Edge Interrupt Enable for Channel 1</p> <p>0 No interrupt will be generated if the set condition for bit ICC61F in register IS occurs.</p> <p>1 An interrupt will be generated if the set condition for bit ICC61F in register IS occurs. The interrupt line that will be activated is selected by bit field INPCC61.</p>

Capture/Compare Unit 6

Field	Bits	Type	Description
ENCC62R	4	rw	Capture, Compare-Match Rising Edge Interrupt Enable for Channel 2 0 No interrupt will be generated if the set condition for bit ICC62R in register IS occurs. 1 An interrupt will be generated if the set condition for bit ICC62R in register IS occurs. The interrupt line that will be activated is selected by bit field INPCC62.
ENCC62F	5	rw	Capture, Compare-Match Falling Edge Interrupt Enable for Channel 2 0 No interrupt will be generated if the set condition for bit ICC62F in register IS occurs. 1 An interrupt will be generated if the set condition for bit ICC62F in register IS occurs. The interrupt line that will be activated is selected by bit field INPCC62.
ENT12OM	6	rw	Enable Interrupt for T12 One-Match 0 No interrupt will be generated if the set condition for bit T12OM in register IS occurs. 1 An interrupt will be generated if the set condition for bit T12OM in register IS occurs. The interrupt line that will be activated is selected by bit field INPT12.
ENT12PM	7	rw	Enable Interrupt for T12 Period-Match 0 No interrupt will be generated if the set condition for bit T12PM in register IS occurs. 1 An interrupt will be generated if the set condition for bit T12PM in register IS occurs. The interrupt line that will be activated is selected by bit field INPT12.

IENH

Capture/Compare Interrupt Enable Register High

Reset Value: 00_H

7	6	5	4	3	2	1	0
EN STR	EN IDLE	EN WHE	EN CHE	0	EN TRPF	EN T13 PM	EN T13 CM
rw	rw	rw	rw	r	rw	rw	rw

Capture/Compare Unit 6

Field	Bits	Type	Description
ENT13CM	0	rw	<p>Enable Interrupt for T13 Compare-Match</p> <p>0 No interrupt will be generated if the set condition for bit T13CM in register IS occurs.</p> <p>1 An interrupt will be generated if the set condition for bit T13CM in register IS occurs. The interrupt line that will be activated is selected by bit field INPT13.</p>
ENT13PM	1	rw	<p>Enable Interrupt for T13 Period-Match</p> <p>0 No interrupt will be generated if the set condition for bit T13PM in register IS occurs.</p> <p>1 An interrupt will be generated if the set condition for bit T13PM in register IS occurs. The interrupt line that will be activated is selected by bit field INPT13.</p>
ENTRPF	2	rw	<p>Enable Interrupt for Trap Flag</p> <p>0 No interrupt will be generated if the set condition for bit TRPF in register IS occurs.</p> <p>1 An interrupt will be generated if the set condition for bit TRPF in register IS occurs. The interrupt line that will be activated is selected by bit field INPERR.</p>
ENCHE	4	rw	<p>Enable Interrupt for Correct Hall Event</p> <p>0 No interrupt will be generated if the set condition for bit CHE in register IS occurs.</p> <p>1 An interrupt will be generated if the set condition for bit CHE in register IS occurs. The interrupt line that will be activated is selected by bit field INPCHE.</p>
ENWHE	5	rw	<p>Enable Interrupt for Wrong Hall Event</p> <p>0 No interrupt will be generated if the set condition for bit WHE in register IS occurs.</p> <p>1 An interrupt will be generated if the set condition for bit WHE in register IS occurs. The interrupt line that will be activated is selected by bit field INPERR.</p>

Capture/Compare Unit 6

Field	Bits	Type	Description
ENIDLE	6	rw	Enable Idle This bit enables the automatic entering of the idle state (bit IDLE will be set) after a wrong hall event has been detected (bit WHE is set). During the idle state, the bit field MCMP is automatically cleared. 0 The bit IDLE is not automatically set when a wrong hall event is detected. 1 The bit IDLE is automatically set when a wrong hall event is detected.
ENSTR	7	rw	Enable Multi-Channel Mode Shadow Transfer Interrupt 0 No interrupt will be generated if the set condition for bit STR in register IS occurs. 1 An interrupt will be generated if the set condition for bit STR in register IS occurs. The interrupt line that will be activated is selected by bit field INPCHE.
0	3	r	Reserved Returns 0 if read; should be written with 0.

Capture/Compare Unit 6

INPL

Capture/Compare Interrupt Node Pointer Register Low

Reset Value: 40_H

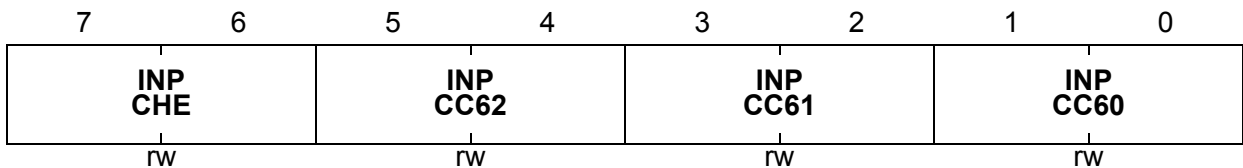

Field	Bits	Type	Description
INPCC60	[1:0]	rw	<p>Interrupt Node Pointer for Channel 0 Interrupts This bit field defines the interrupt output line, which is activated due to a set condition for bit ICC60R (if enabled by bit ENCC60R) or for bit ICC60F (if enabled by bit ENCC60F).</p> <p>00 Interrupt output line SR0 is selected. 01 Interrupt output line SR1 is selected. 10 Interrupt output line SR2 is selected. 11 Interrupt output line SR3 is selected.</p>
INPCC61	[3:2]	rw	<p>Interrupt Node Pointer for Channel 1 Interrupts This bit field defines the interrupt output line, which is activated due to a set condition for bit ICC61R (if enabled by bit ENCC61R) or for bit ICC61F (if enabled by bit ENCC61F).</p> <p>00 Interrupt output line SR0 is selected. 01 Interrupt output line SR1 is selected. 10 Interrupt output line SR2 is selected. 11 Interrupt output line SR3 is selected.</p>

Capture/Compare Unit 6

Field	Bits	Type	Description
INPCC62	[5:4]	rw	<p>Interrupt Node Pointer for Channel 2 Interrupts This bit field defines the interrupt output line, which is activated due to a set condition for bit ICC62R (if enabled by bit ENCC62R) or for bit ICC62F (if enabled by bit ENCC62F).</p> <p>00 Interrupt output line SR0 is selected. 01 Interrupt output line SR1 is selected. 10 Interrupt output line SR2 is selected. 11 Interrupt output line SR3 is selected.</p>
INPCHE	[7:6]	rw	<p>Interrupt Node Pointer for the CHE Interrupt This bit field defines the interrupt output line, which is activated due to a set condition for bit CHE (if enabled by bit ENCHE) or for bit STR (if enabled by bit ENSTR).</p> <p>00 Interrupt output line SR0 is selected. 01 Interrupt output line SR1 is selected. 10 Interrupt output line SR2 is selected. 11 Interrupt output line SR3 is selected.</p>

INPH

Capture/Compare Interrupt Node Pointer Register High

Reset Value: 39_H

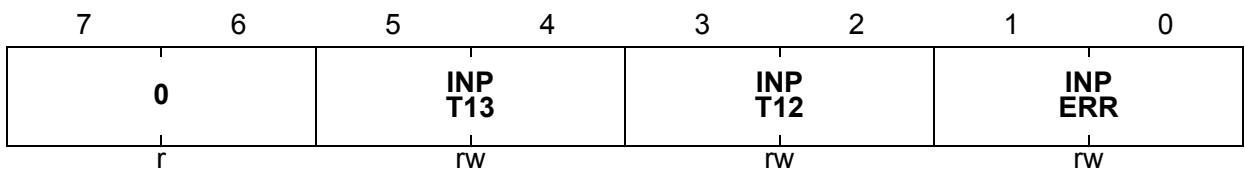

Capture/Compare Unit 6

Field	Bits	Type	Description
INPERR	[1:0]	rw	Interrupt Node Pointer for Error Interrupts This bit field defines the interrupt output line, which is activated due to a set condition for bit TRPF (if enabled by bit ENTRPF) or for bit WHE (if enabled by bit ENWHE). 00 Interrupt output line SR0 is selected. 01 Interrupt output line SR1 is selected. 10 Interrupt output line SR2 is selected. 11 Interrupt output line SR3 is selected.
INPT12	[3:2]	rw	Interrupt Node Pointer for Timer T12 Interrupts This bit field defines the interrupt output line, which is activated due to a set condition for bit T12OM (if enabled by bit ENT12OM) or for bit T12PM (if enabled by bit ENT12PM). 00 Interrupt output line SR0 is selected. 01 Interrupt output line SR1 is selected. 10 Interrupt output line SR2 is selected. 11 Interrupt output line SR3 is selected.
INPT13	[5:4]	rw	Interrupt Node Pointer for Timer T13 Interrupts This bit field defines the interrupt output line, which is activated due to a set condition for bit T13CM (if enabled by bit ENT13CM) or for bit T13PM (if enabled by bit ENT13PM). 00 Interrupt output line SR0 is selected. 01 Interrupt output line SR1 is selected. 10 Interrupt output line SR2 is selected. 11 Interrupt output line SR3 is selected.
0	[7:6]	r	Reserved Returns 0 if read; should be written with 0.

13 Analog-to-Digital Converter

The XC866 includes a high-performance 10-bit Analog-to-Digital Converter (ADC) with eight multiplexed analog input channels. The ADC uses a successive approximation technique to convert the analog voltage levels from up to eight different sources.

Features:

- Successive approximation
- 8-bit or 10-bit resolution
(TUE of ± 1 LSB and ± 2 LSB, respectively)
- Eight analog channels
- Four independent result registers
(configurable for FIFO functionality)
- Result data protection for slow CPU access
(wait-for-read mode)
- Single conversion mode
- Autoscan functionality
- Limit checking for conversion results
- Data reduction filter
(accumulation of up to 2 conversion results)
- Two independent conversion request sources with programmable priority
- Selectable conversion request trigger
- Flexible interrupt generation with configurable service nodes
- Programmable sample time
- Programmable clock divider
- Cancel/restart feature for running conversions
- Integrated sample and hold circuitry
- Compensation of offset errors
- Low power modes

13.1 Structure Overview

The ADC module consists of two main parts, i.e., analog and digital, with each containing independent building blocks.

The analog part includes:

- Analog input multiplexer (for selecting the channel to be converted)
- Analog converter stage (e.g., capacitor network and comparator as part of the ADC)
- Digital control part of the analog converter stage (for controlling the analog-to-digital conversion process and generating the conversion result)

The digital part defines and controls the overall functionality of the ADC module, and includes:

- Digital data and conversion request handling (for controlling the conversion trigger mechanisms and handling the conversion results)
- Bus interface to the device-internal data bus (for controlling the interrupts and register accesses)

The block diagram of the ADC module is shown in **Figure 13-1**. The analog input channel x ($x = 0 - 7$) is available at port pin P2.x/ANx.

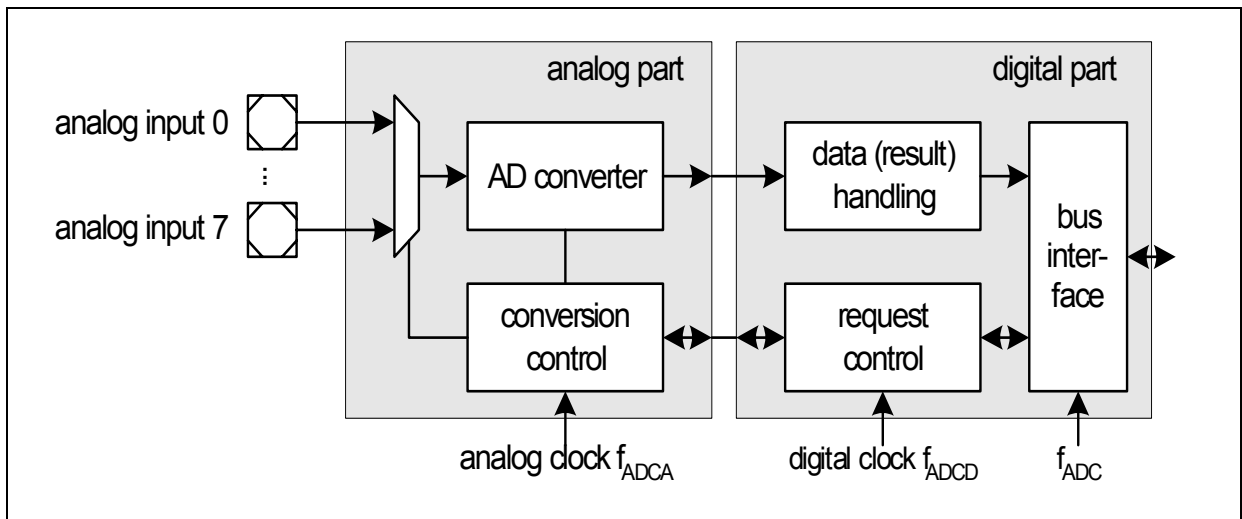

Figure 13-1 Overview of ADC Building Blocks

13.2 Clocking Scheme

A common module clock f_{ADC} generates the various clock signals used by the analog and digital parts of the ADC module:

- f_{ADCA} is input clock for the analog part.
- f_{ADCI} is internal clock for the analog part (defines the time base for conversion length and the sample time). This clock is generated internally in the analog part, based on the input clock f_{ADCA} to generate a correct duty cycle for the analog components.
- f_{ADCD} is input clock for the digital part. This clock is used for the arbiter (defines the duration of an arbitration round) and other digital control structures (e.g., registers and the interrupt generation).

The internal clock for the analog part f_{ADCI} is limited to a maximum frequency of 10 MHz. Therefore, the ADC clock prescaler must be programmed to a value that ensures f_{ADCI} does not exceed 10 MHz. The prescaler ratio is selected by bit field CTC in register GLOBCTR. A prescaling ratio of 32 can be selected when the maximum performance of the ADC is not required.

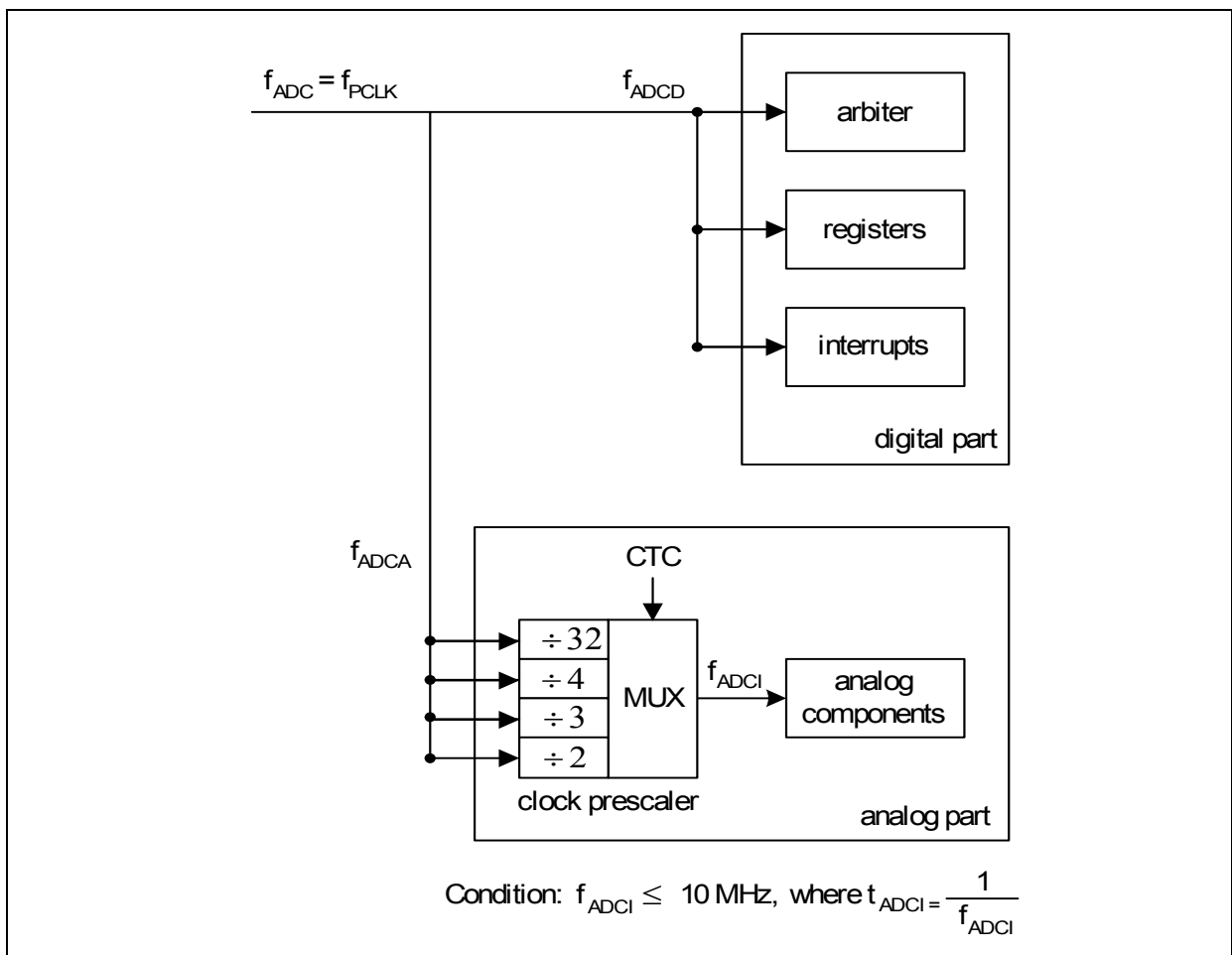

Figure 13-2 Clocking Scheme

Analog-to-Digital Converter

For module clock $f_{ADC} = 26.7$ MHz, the analog clock f_{ADCI} frequency can be selected as shown in **Table 13-1**.

Table 13-1 f_{ADCI} Frequency Selection

Module Clock f_{ADC}	CTC	Prescaling Ratio	Analog Clock f_{ADCI}
26.7 MHz	00 _B	÷ 2	13.3 MHz (N.A)
	01 _B	÷ 3	8.9 MHz
	10 _B	÷ 4	6.7 MHz
	11 _B (default)	÷ 32	833.3 kHz

As f_{ADCI} cannot exceed 10 MHz, bit field CTC should not be set to 00_B when f_{ADC} is 26.7 MHz. During slow-down mode where f_{ADC} may be reduced to 13.3 MHz, 6.7 MHz etc., CTC can be set to 00_B as long as the divided analog clock f_{ADCI} does not exceed 10 MHz. However, it is important to note that the conversion error could increase due to loss of charges on the capacitors, if f_{ADC} becomes too low during slow-down mode.

13.2.1 Conversion Timing

The analog-to-digital conversion procedure consists of the following phases:

- Synchronization phase (t_{SYN})
- Sample phase (t_S)
- Conversion phase
- Write result phase (t_{WR})

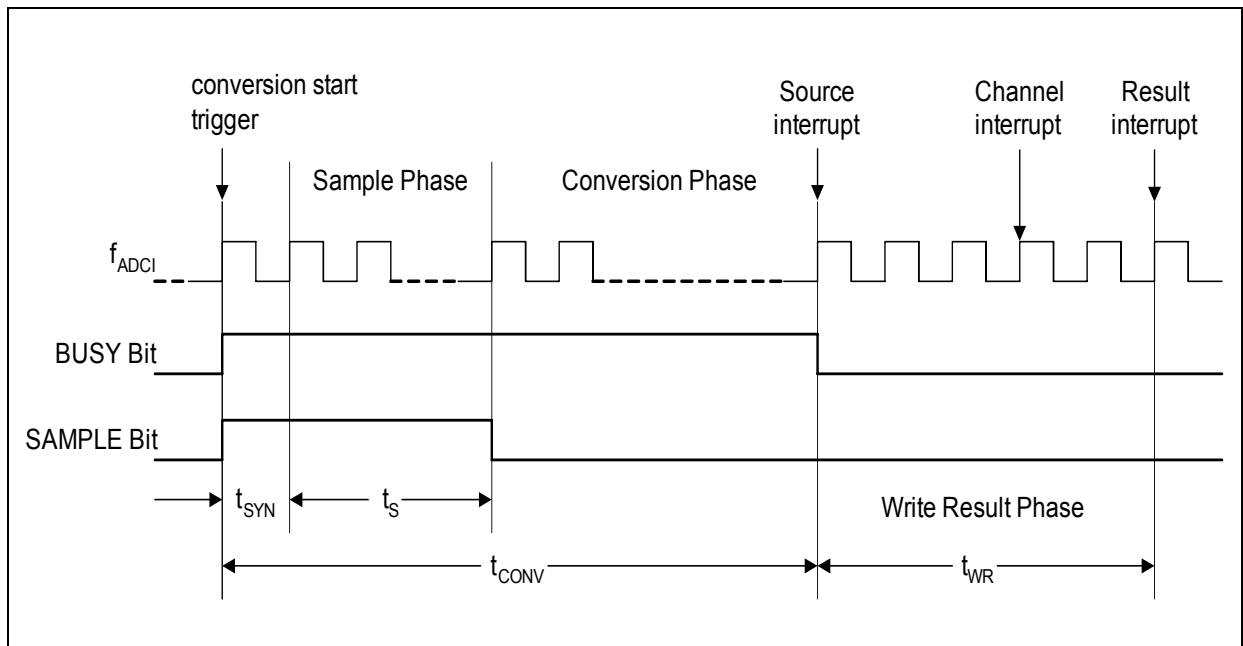

Figure 13-3 Conversion Timing

Synchronization Phase t_{SYN}

One f_{ADCI} period is required for synchronization between the conversion start trigger (from the digital part) and the beginning of the sample phase (in the analog part). The BUSY and SAMPLE bits will be set with the conversion start trigger.

Sample Phase t_S

During this period, the analog input voltage is sampled. The internal capacitor array is connected to the selected analog input channel and is loaded with the analog voltage to be converted. The analog voltage is internally fed to a voltage comparator. With the beginning of the sampling phase, the SAMPLE and BUSY flags in register GLOBSTR are set. The duration of this phase is common to all analog input channels and is controlled by bit field STC in register INPCR0:

$$t_S = (2 + STC) \times t_{ADCI} \quad [13.1]$$

Conversion Phase

During the conversion phase, the analog voltage is converted into an 8-bit or 10-bit digital value using the successive approximation technique with a binary weighted capacitor network. At the beginning of the conversion phase, the SAMPLE flag is reset (to indicate the sample phase is over), while the BUSY flag continues to be asserted. The BUSY flag is deasserted only at the end of the conversion phase with the corresponding source interrupt (of the source that started the conversion) asserted.

Write Result Phase t_{WR}

At the end of the conversion phase, the corresponding channel interrupt (of the converted channel) is asserted three f_{ADCI} periods later, after the limit checking has been performed. The result interrupt is asserted, once the conversion result has been written into the target result register.

Total Conversion Time t_{CONV}

The total conversion time (synchronizing + sampling + charge redistribution) t_{CONV} is given by:

$$t_{\text{CONV}} = t_{\text{ADC}} \times (1 + r \times (3 + n + \text{STC})) \quad [13.2]$$

where

$r = \text{CTC} + 2$ for $\text{CTC} = 00_{\text{B}}, 01_{\text{B}}$ or 10_{B} ,

$r = 32$ for $\text{CTC} = 11_{\text{B}}$,

$\text{CTC} = \text{Conversion Time Control}$,

$\text{STC} = \text{Sample Time Control}$,

$n = 8$ or 10 (for 8-bit and 10-bit conversion, respectively),

$t_{\text{ADC}} = 1 / f_{\text{ADC}}$

Example:

$\text{STC} = 00_{\text{H}}$,

$\text{CTC} = 01_{\text{B}}$,

$f_{\text{ADC}} = 26.7 \text{ MHz}$,

$n = 10$,

$$t_{\text{CONV}} = t_{\text{ADC}} \times (1 + 3 \times (3 + 10 + 0)) = 1.5 \mu\text{s}$$

13.3 Low Power Mode

The ADC module may be disabled, either partially or completely, when no conversion is required in order to reduce power consumption:

- The analog part of the ADC module may be disabled by resetting the ANON bit. This causes the generation of f_{ADCI} to be stopped and results in a reduction in power consumption. Conversions are possible only by enabling the analog part (ANON = 1) again. The wake-up time is approximately 100 ns.
Refer to [Section 13.7.1](#) for register description of disabling the ADC analog part.
- If the ADC functionality is not required at all, it can be completely disabled by gating off its clock input (f_{ADC}) for maximal power reduction. This is done by setting bit ADC_DIS in register PMCON1 as described below. Refer to [Chapter 8.1.4](#) for details on peripheral clock management.

PMCON1

Power Mode Control Register 1

Reset Value: 00_H

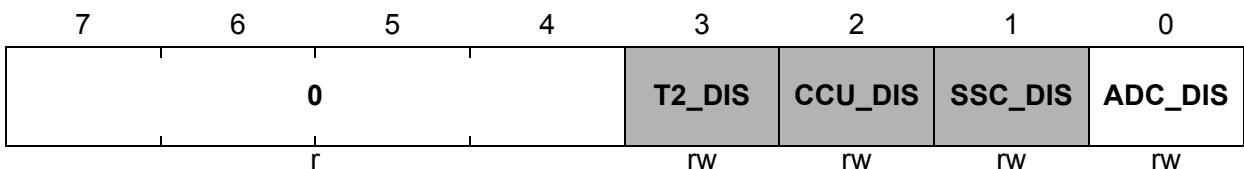

The function of the shaded bit is not described here

Field	Bits	Type	Description
ADC_DIS	0	rw	ADC Disable Request. Active high. 0 ADC is in normal operation (default) 1 Request to disable the ADC
0	[7:4]	r	Reserved Returns 0 if read; should be written with 0.

13.4 Functional Description

The ADC module functionality includes:

- Two different conversion request sources (sequential and parallel) with independent registers. The request sources are used to trigger conversions due to external events (synchronization to PWM signals), sequencing schemes, etc.
- An arbiter that regularly scans the request sources to find the channel with the highest priority for the next conversion. The priority of each source can be programmed individually to obtain the required flexibility to cover the desired range of applications.
- Control registers for each of the eight channels that define the behavior of each analog input (such as the interrupt behavior, a pointer to a result register, a pointer to a channel class, etc.).
- An input class register that delivers general channel control information (sample time) from a centralized location.
- Four result registers (instead of one result register per analog input channel) for storing the conversion results and controlling the data reduction. This allows the creation of result data FIFOs.
- A decimation stage for conversion results, adding the incoming result to the value already stored in the targeted result register. This stage allows fast consecutive conversions without the risk of data loss for slow CPU clock frequency.

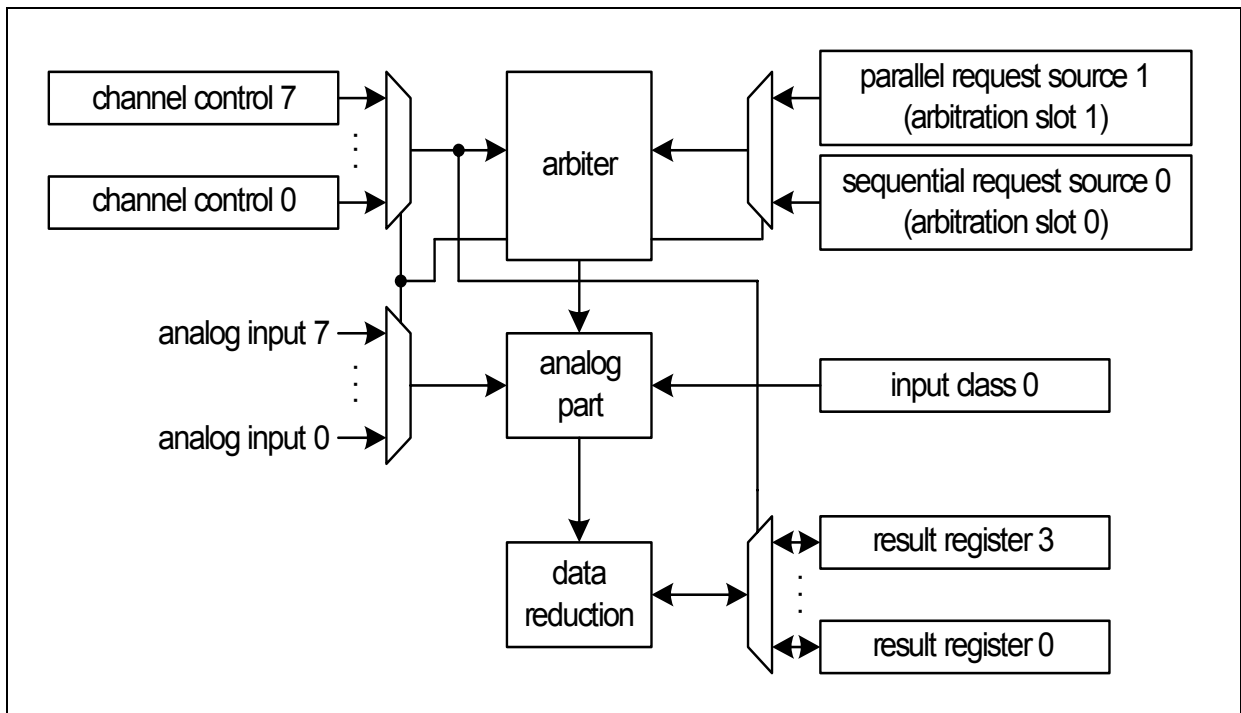

Figure 13-4 ADC Block Diagram

13.4.1 Request Source Arbiter

The arbiter can operate in two modes that are selectable by bit ARBM:

- Permanent arbitration:
In this mode, the arbiter will continuously poll the request sources even when there is no pending conversion request.
- Arbitration started by pending conversion request:
In this mode, the arbiter will start polling the request sources only if there is at least one conversion pending request.

Once started, the arbiter polls the two request sources (source x at slot x , $x = 0 - 1$) to find the analog channel with the highest priority that must be converted. For each arbitration slot, the arbiter polls the request pending signal (REQPND) and the channel number valid signal (REQCHNRV) of one request source. The sum of all arbitration slots is called an arbitration round. An arbitration slot must be enabled ($ASEN_x = 1$) before it can take part in the arbitration.

Each request source has a source priority that can be programmed via bit $PRIO_x$. Starting with request source 0 (arbitration slot 0), the arbiter checks if a request source has a pending request ($REQPND = 1$) for a conversion. If more than one request source is found with the same programmed priority level and a pending conversion request, the channel specified by the request source that was found first is selected. The REQCHNRV signal is also checked by the arbiter and a conversion can only be started if $REQCHNRV = 1$ (and $REQPND = 1$). If both request sources are programmed with the same priority, the channel number specified by request source 0 will be converted first since it is connected to arbitration slot 0.

The period t_{ARB} of a complete arbitration round is fixed at:

$$t_{ARB} = 4 * t_{ADCD} \quad [13.3]$$

Refer to [Section 13.7.2](#) for register description of priority and arbitration control.

13.4.2 Conversion Start Modes

At the end of each arbitration round, the arbiter would have found the request source with the highest priority and a pending conversion request. It stores the arbitration result, namely the channel number, the sample time and the targeted result register for further actions.

If the analog part is idle, a conversion can be started immediately. If a conversion is currently running, the arbitration result is compared to the priority of the currently running conversion. If the current conversion has the same or a higher priority, it will continue to completion. Immediately after its completion, the next conversion can begin. As soon as the analog part is idle and the arbiter has output a conversion request, the conversion will start.

In case the new conversion request has a higher priority than the current conversion, two conversion start modes exist (selectable by bit CSM_x, x = 0 - 1):

- **Wait-for-Start:**
In this mode, the current conversion is completed normally. The pending conversion request will be treated immediately after the conversion is completed. The conversion start takes place as soon as possible.
- **Cancel-Inject-Repeat:**
In this mode, the current conversion is aborted immediately if a new request with a higher priority has been found. The new conversion is started as soon as possible after the abort action. The aborted conversion request is restored in the request source that has requested the aborted conversion. As a result, it takes part in the next arbitration round. The priority of an active request source (including pending or active conversion) must not be changed by software. The abort will not be accepted during the last 3 clock cycles of a running conversion.

Refer to [Section 13.7.2](#) for register description relating to conversion start control.

13.4.3 Channel Control

Each channel has its own control information that defines the target result register for the conversion result (see [Section 13.7.4](#)). The only control information that is common to all channels is the sampling time defined by the input class register (see [Section 13.7.5](#)).

13.4.4 Sequential Request Source

13.4.4.1 Overview

The sequential request source at arbitration slot 0 requests one conversion after another for channel numbers between 0 and 7. The queue stage stores the requested channel number and some additional control information. As a result, the order in which the channels are to be converted is freely programmable without restrictions in the sequence. The additional control information is used to enable the request source interrupt (when the requested channel conversion is completed) and to enable the automatic refill process.

A sequential source consists of a queue stage (Q0R0), a backup stage (QBUR0) and a mode control register (QMR0). The backup stage stores the information about the latest conversion requested after it has been aborted. If the backup register contains an aborted request ($V = 1$), it is treated before the entry in the queue stage. This implies that only the bit V in the backup register is cleared when the requested conversion is started. If the bit V in the backup register is not set, the bit V in the queue stage is reset when the requested conversion is started. The request source can take part in the source arbitration if the backup stage or queue stage contains a valid request ($V = 1$).

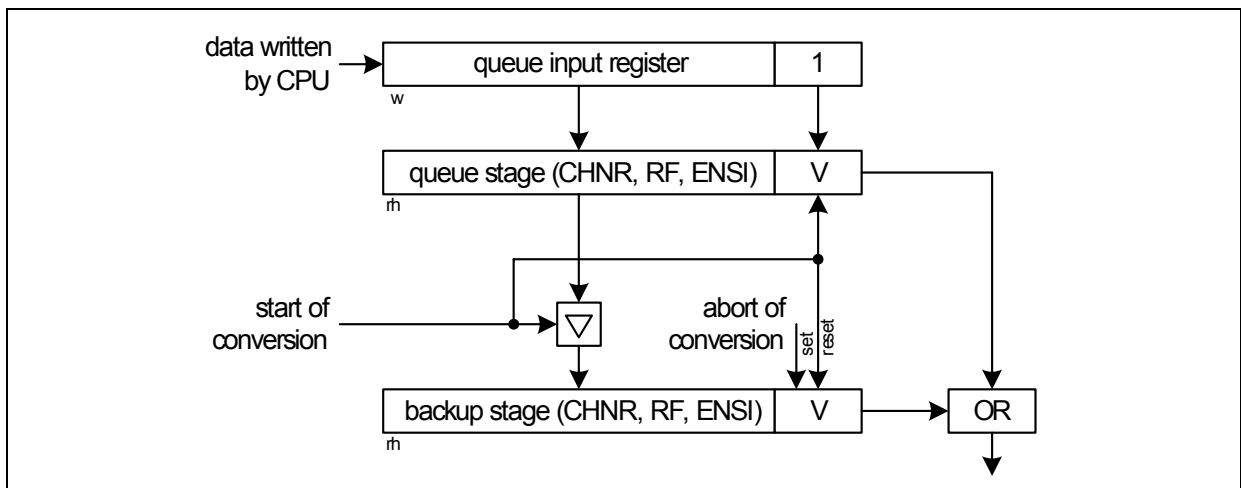

Figure 13-5 Base Structure of Sequential Request Source

The automatic refill feature can be activated ($RF = 1$) to allow automatic re-insertion of the pending request into the queue stage after a successful execution (conversion start). Otherwise, the pending request will be discarded once it is executed. While the automatic refill feature is enabled, software should not write data to the queue input register.

The write address in which to enter a conversion request is given by the write-only queue input register (QINR0). If the queue stage is empty ($V = 0$), the written value will be stored there (bit V becomes set), or else the write action is ignored.

Refer to [Section 13.7.6](#) for description of the sequential request source registers.

13.4.4.2 Request Source Control

If the conversion requested by the source is not related to an external trigger event ($EXTR = 0$), the valid bit $V = 1$ directly requests the conversion by setting signals $REQPND$ and $REQCHNRV$ to 1. In this case, no conversion will be requested if $V = 0$. A gating mechanism allows the user to enable/disable conversion requests according to bit $ENGT$.

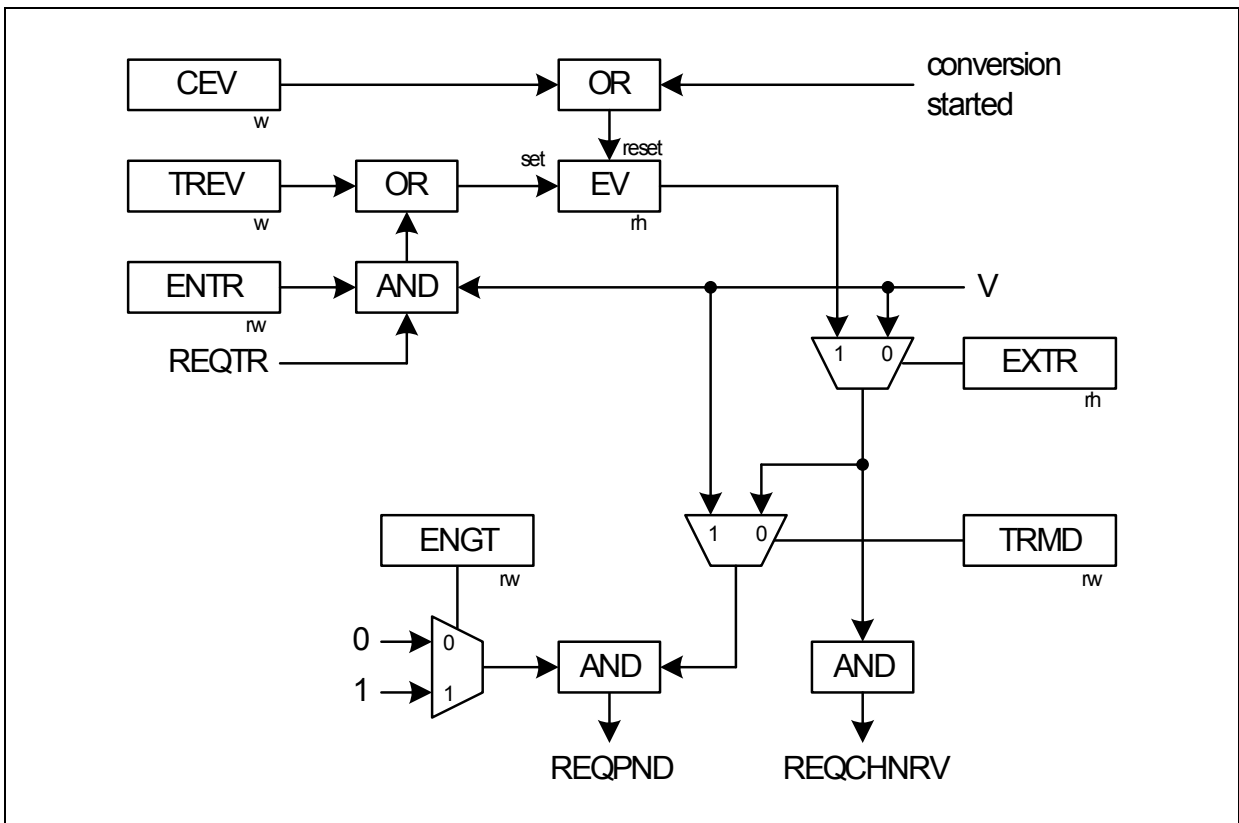

Figure 13-6 Sequential Request Source Control

If the requested conversion is sensitive to an external trigger event ($EXTR = 1$), the signal $REQTR$ can be taken into account (with $ENTR = 1$) or the software can write $TREV = 1$. Both actions set the event flag EV . The event flag $EV = 1$ indicates that an external event has taken place and a conversion can be requested (EV can be set only if a conversion request is valid with $V = 1$). In this case, the signal $REQCHNRV$ is derived from bit EV .

Bit $TRMD$ (trigger mode) offers the possibility to wait, with the valid bit already set, for an event to be detected before taking part in the arbitration. This ensures that the reaction to an event is with minimum delay. If this feature is not desired ($TRMD = 0$), the event bit EV can be used to generate both $REQPND$ and $REQCHNRV$.

13.4.5 Parallel Request Source

13.4.5.1 Overview

The parallel request source at arbitration slot 1 generates one or more conversion requests for channel numbers between 4 and 7 in parallel. The requests are always treated one after the other (in separate arbitration rounds) in a predefined sequence (higher channel numbers before lower channel numbers).

The parallel request source consists of a conversion request control register (CRCR1), a conversion request pending register (CRPR1) and a conversion request mode register (CRMR1). The contents of the conversion request control register are copied (overwrite) to the conversion request pending register when a selected load event (LDE) occurs. The type of the event defines the behavior and the trigger of the request source.

The activation of a conversion request to the arbiter may be started if the content of the conversion pending register is not 0. The highest bit position number among the pending bits with values equal to 1 specifies the channel number for conversion. To take part in the source arbitration, both the REQCHNRV and REQPND signals must be 1.

Refer to [Section 13.7.7](#) for description of the parallel request source registers.

13.4.5.2 Request Source Control

All conversion pending bits are ORed together to deliver an intermediate signal PND for generating REQCHNRV and REQPND. The signal PND is gated with bit ENGT, allowing the user to enable/disable conversion requests. See [Figure 13-7](#).

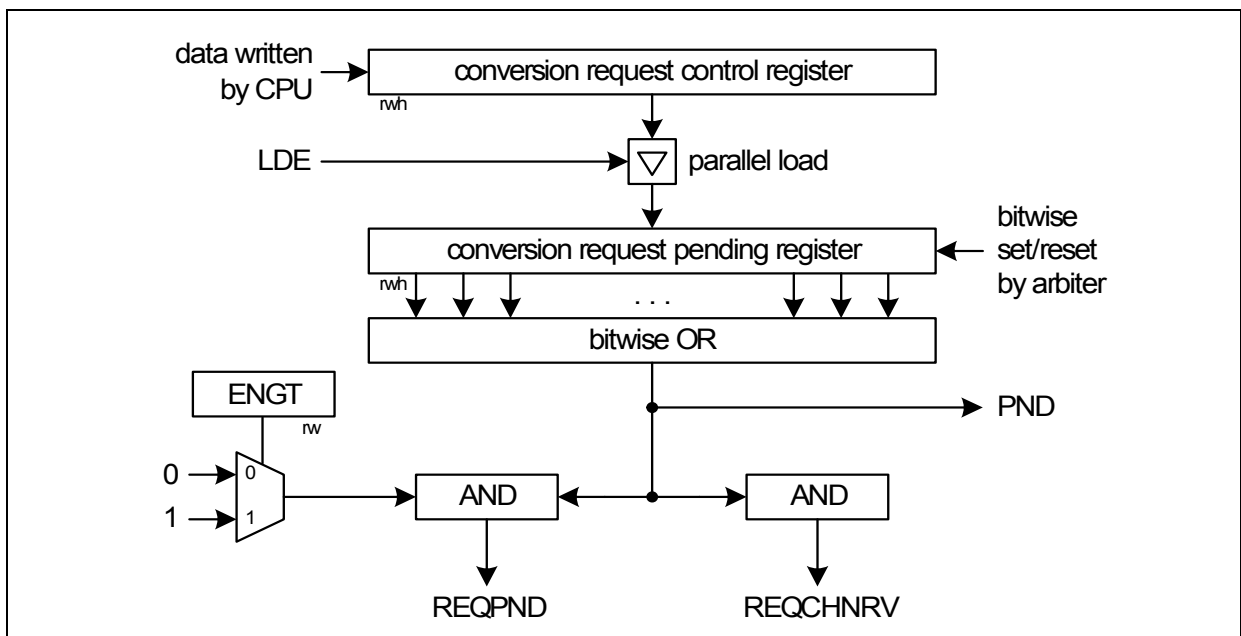

Figure 13-7 Parallel Request Source Control

The load event for a parallel load can be:

- External trigger at the input line REQTR. See [Section 13.4.5.3](#).
- Write operation to a specific address of the conversion request control register. See [Section 13.4.5.4](#).
- Write operation with LDEV = 1 to the request source mode register. See [Section 13.4.5.4](#).
- Source internal action (conversion completed and PND = 0 for autoscan mode). See [Section 13.4.5.5](#).

Each bit (bit x, x = 4 - 7) in the conversion request control/pending registers corresponds to one analog input channel. The bit position directly defines the channel number. The bits in the conversion request pending register can be set or reset bitwisely by the arbiter:

- The corresponding bit in the conversion request pending register is automatically reset when the arbiter indicates the start of conversion for this channel.
- The bit is automatically set when the arbiter indicates that the conversion has been aborted.

A source interrupt can be generated (if enabled) when a conversion (requested by this source) is completed while PND = 0. These rules apply only if the request source has triggered the conversion.

13.4.5.3 External Trigger

The conversion request for the parallel source (and also the sequential source) can be synchronized to an external trigger event. For the parallel source, this is done by coupling the reload event to a request trigger input, REQTR.

13.4.5.4 Software Control

The load event for the parallel source can also be generated under software control in two ways:

- The conversion request control register can be written at two different addresses (CRCR1 and CRPR1). Accessed at CRCR1, the write action changes only the bits in this register. Accessed at CRPR1, the load event will take place one clock cycle after the write access. This automatic load event can be used to start conversions with a single move operation. In this case, the information about the channels to be converted is given as an argument in the move instruction.
- Bit LDEV can be written with 1 by software to trigger the load event. In this case, the load event does not contain any information about the channels to be converted, but always takes the contents of the conversion request control register. This allows the conversion request control register to be written at a second address without triggering the load event.

13.4.5.5 Autoscan

The autoscan is a functionality of the parallel source. If autoscan mode is enabled, the load event takes place when the conversion is completed while $PND = 0$, provided the parallel request source has triggered the conversion. This automatic reload feature allows channels 4 and 7 to be constantly scanned for pending conversion requests without the need for external trigger or software action.

13.4.6 Wait-for-Read Mode

The wait-for-read mode can be used for all request sources to allow the CPU to treat each conversion result independently without the risk of data loss. Data loss can occur if the CPU does not read a conversion result in a result register before a new result overwrites the previous one.

In wait-for-read mode, the conversion request generated by a request source for a specific channel will be disabled (and conversion not possible) if the targeted result register contains valid data (indicated by its valid flag being set). Conversion of the requested channel will not start unless the valid flag of the targeted result register is cleared (data is invalid). The wait-for-read mode for a result register can be enabled by setting bit WFR (see [Section 13.7.8](#)).

13.4.7 Result Generation

13.4.7.1 Overview

The result generation of the ADC module consists of several parts:

- A limit checking unit, comparing the conversion result to two selected boundary values (BOUND0 and BOUND1). A channel interrupt can be generated according to the limit check result.
- A data reduction filter, accumulating the conversion results. The accumulation is done by adding the new conversion result to the value stored in the selected result register.
- Four result registers, storing the conversion results. The software can read the conversion result from the result registers. The result register used to store the conversion result is selected individually for each input channel.

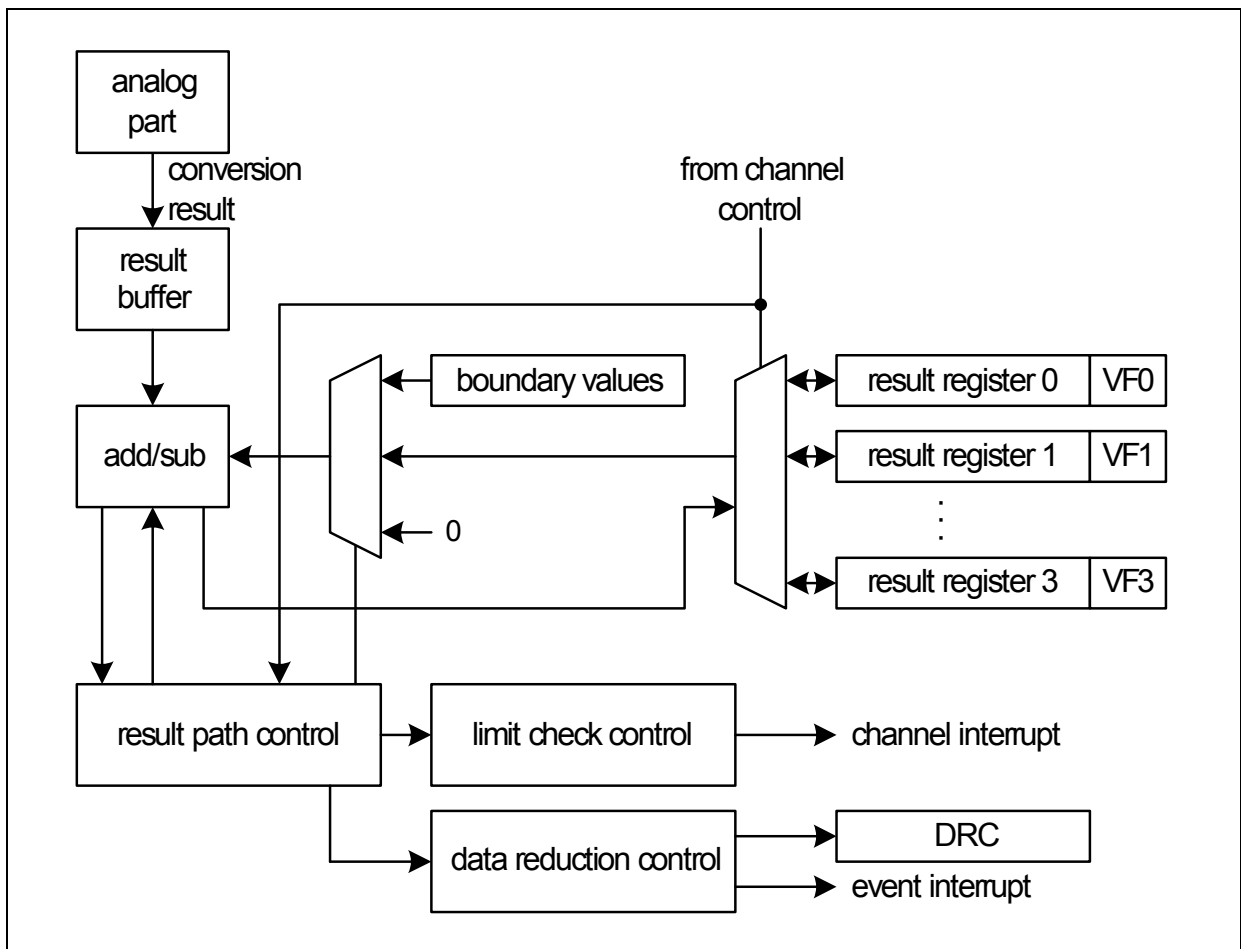

Figure 13-8 Result Path

Refer to [Section 13.7.8](#) for description of the result generation registers.

13.4.7.2 Limit Checking

The limit checking and the data reduction filter are based on a common add/subtract structure. The incoming result is compared with BOUND0, then with BOUND1. Depending on the result flags (lower-than compare), the limit checking unit can generate a channel interrupt. It can become active when the valid result of the data reduction filter is stored in the selected result register.

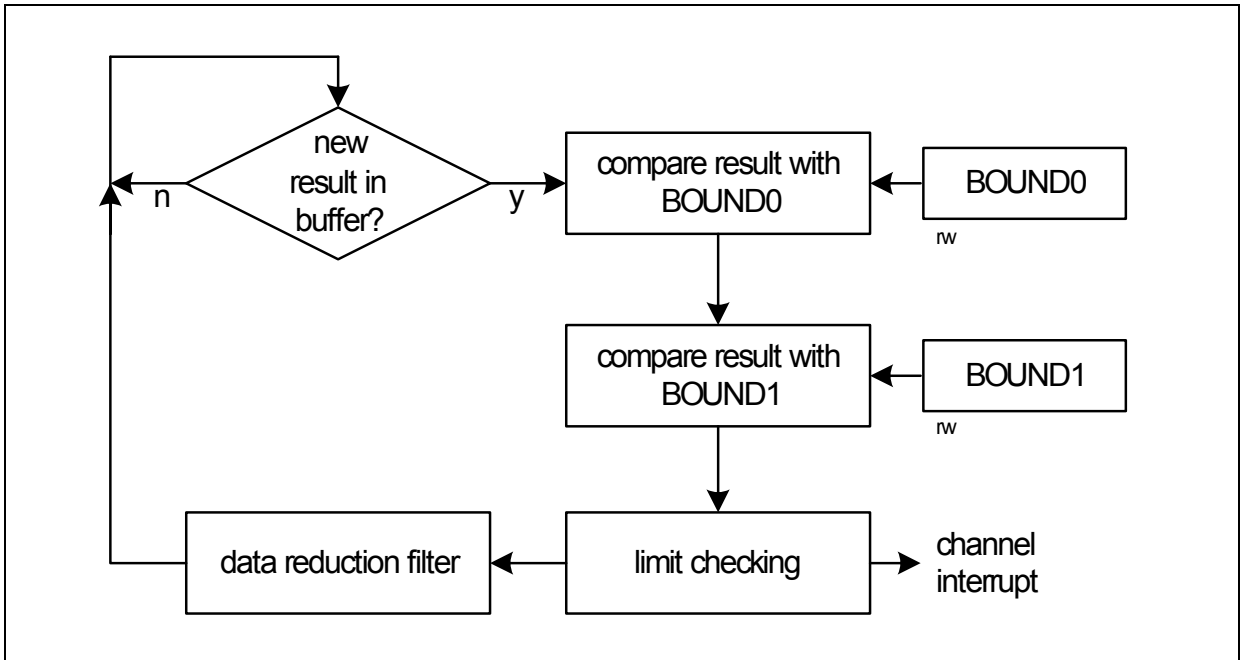

Figure 13-9 Limit Checking Flow

13.4.7.3 Data Reduction Filter

Each result register can be controlled to enable or disable the data reduction filter. The data reduction block allows the accumulation of conversion results for anti-aliasing filtering or for averaging. A pseudo-parallel sampling on two analog inputs is possible by converting the channels A - B - B - A in a quick sequence. The result register for A stores the sum of both conversions of channel A and the result register B works similarly for channel B.

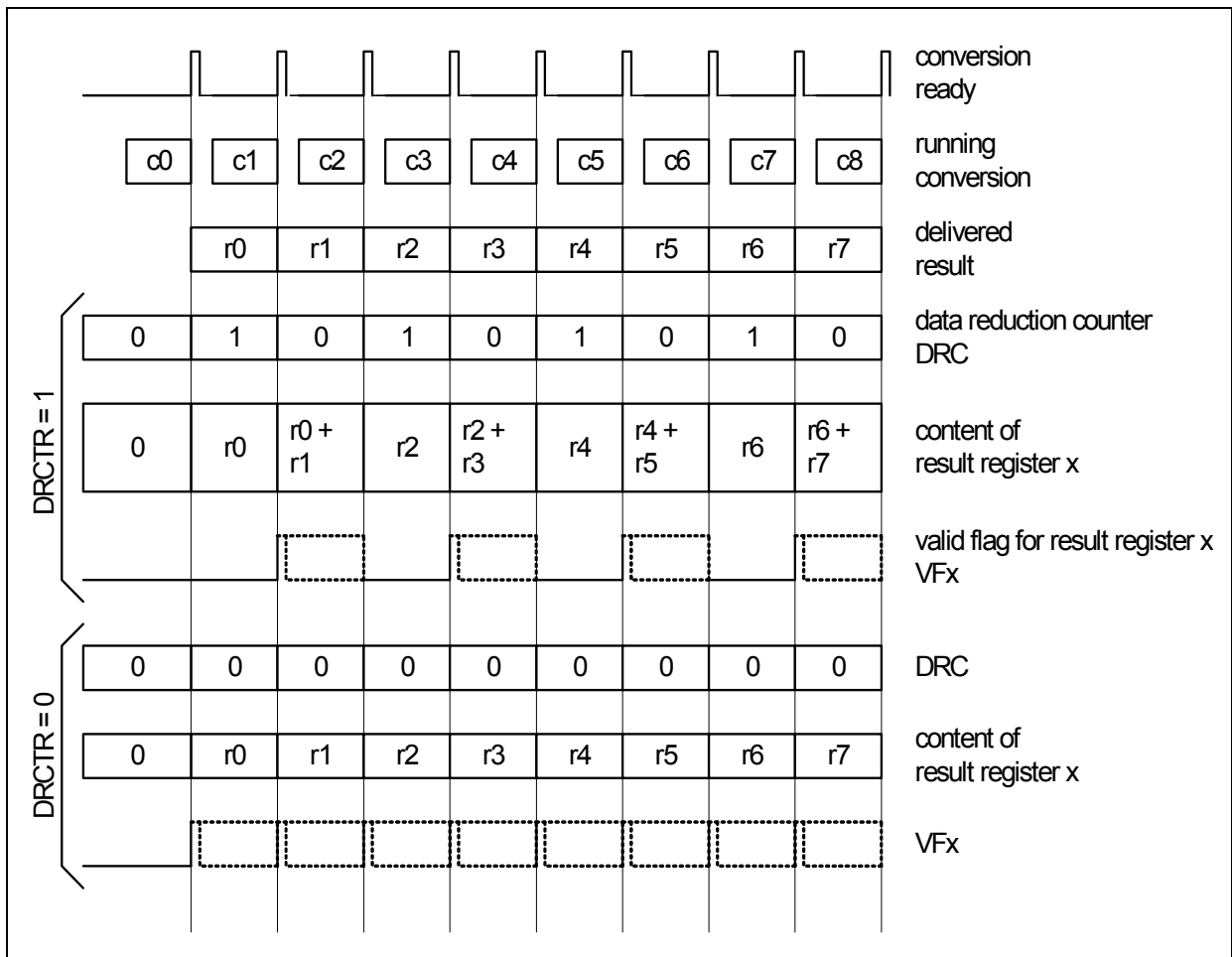

Figure 13-10 Data Reduction Flow

If DRC is 0 and a new conversion result comes in, DRC is reloaded with its reload value (defined by bit DRCTR in the result control register) and the value of 0 is added to the conversion result (instead of the previous result register content). Then, the complete result is stored in the selected result register. If the reload value is 0 (data reduction filter disabled), accumulation is done over one conversion. Hence, a result event is generated and the valid bit (VF) for the result register becomes set. If the reload value is 1 (data reduction filter enabled), accumulation is done over two conversions. In this case, neither a result event is generated nor the valid bit is set.

Analog-to-Digital Converter

If DRC is 1 and a new conversion result comes in, the data reduction filter adds the incoming result to the value already stored in the result register and decrements DRC. After this addition, the complete result is stored in the selected result register. The result event is generated and the valid bit becomes set.

It is possible to have an identical cycle behavior of the path to the result register, with the data reduction filter being enabled or disabled. Furthermore, an overflow of the result register is avoided, because a maximum of 2 conversion results are added (a 10-bit result added twice delivers a maximum of 11 bits).

13.4.7.4 Result FIFO Functionality

The four result registers can be independently configured to provide a 2, 3 or 4-stage FIFO functionality. This allows the storing of measurement results with 'relaxed' CPU access timing.

If the FIFO mechanism is enabled ($FEN = 1$) for result register x (independent from the read views), the following actions take place (the setting of result register $x+1$ has no influence on these actions).

If the valid flag VFx is not set (result register x does not contain valid data) and $VFx+1$ (of result register $x+1$) is set, the contents of result register $x+1$ are transferred to result register x . Furthermore, VFx becomes set and $VFx+1$ becomes reset. The setting of VFx can generate an event interrupt.

A result interrupt x is generated when new data is stored in result register x if the previous register ($x-1$) is not enabled for FIFO functionality.

13.4.7.5 Result Register View

In order to cover a wide range of applications, the content of result register x ($x = 0$ to 3) is available as different read views at different addresses (see [Figure 13-11](#)):

- Normal read view $RESRxL/H$:
This view delivers the 8-bit or 10-bit conversion result.
- Accumulated read view $RESRAXL/H$:
This view delivers the accumulated 9-bit or 11-bit conversion result.

All conversion results (with or without accumulation) are stored in the result registers, but can be viewed at either $RESRxL/H$ or $RESRAXL/H$ which shows different data alignment and width.

When the data reduction filter is enabled ($DRCTR = 1$), read access should be performed on $RESRAXL/H$ as it shows the full 9-bit ($R8:R0$) or 11-bit ($R10:R0$) accumulated conversion result. Reading from $RESRxL/H$ gives the appended (MSB unavailable) accumulated result.

When the data reduction filter is disabled ($DRCTR = 0$), the user can read the 8-bit or 10-bit conversion result from either $RESRxL/H$ or $RESRAXL/H$. In particular, for 8-bit

Analog-to-Digital Converter

conversion (without accumulation), the result can be read from RESRxH with a single instruction. Hence, depending on the application requirement, the user can choose to read from the different views.

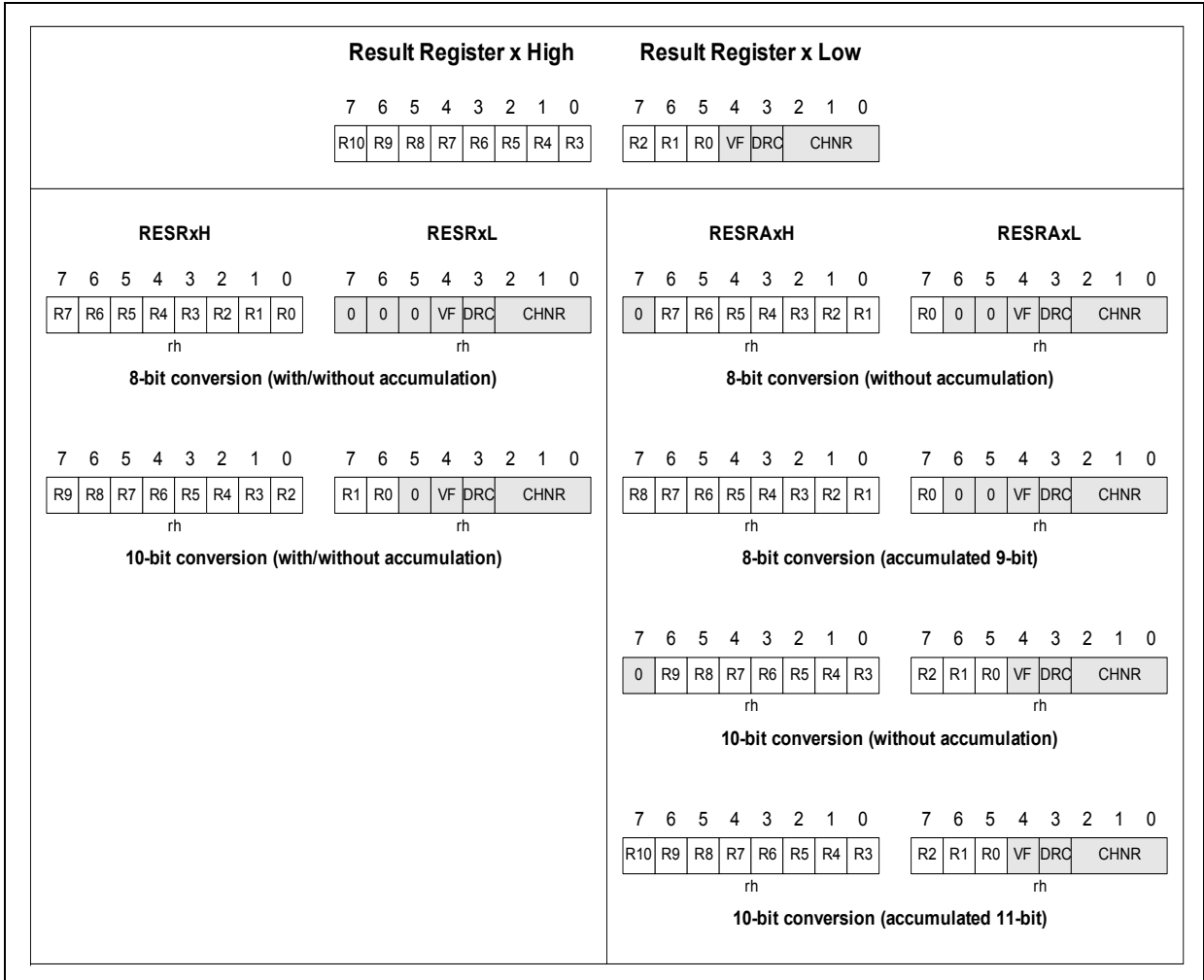

Figure 13-11 Result Register View

13.4.8 Interrupts

The ADC module provides 2 service request outputs SR[1:0] that can be activated by different interrupt sources.

The interrupt structure of the ADC supports two different types of interrupt sources:

- Event Interrupts: Activated by events of the request sources (source interrupts) or result registers (result interrupts).
- Channel Interrupts: Activated by the completion of any input channel conversion. They are enabled according to the control bits for the limit checking. The settings are defined individually for each input channel.

The interrupt compressor is an OR-combination of all incoming interrupt pulses for each of the SR lines.

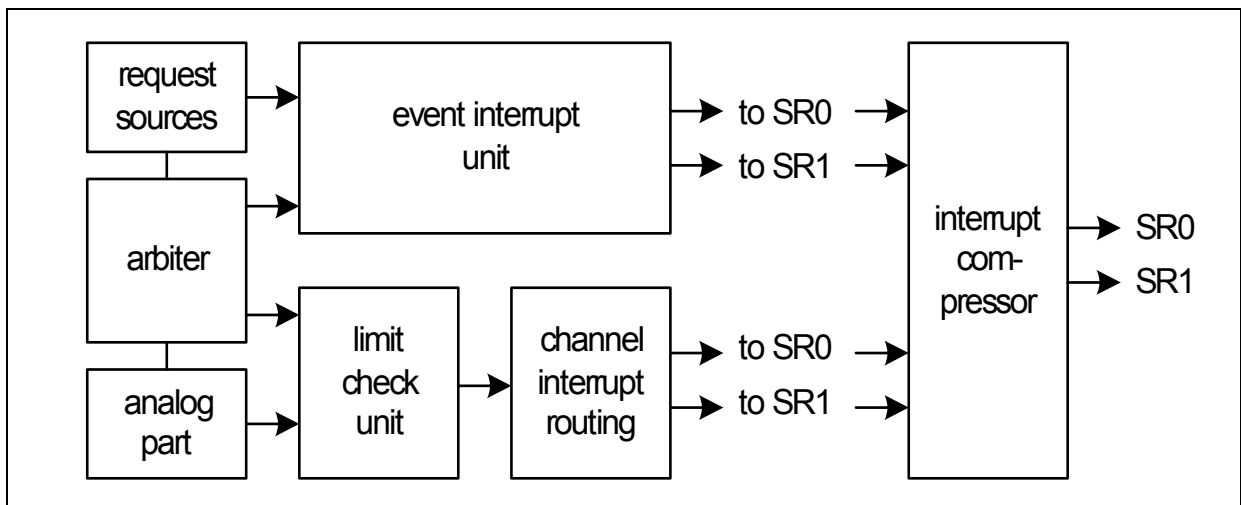

Figure 13-12 Interrupt Overview

Refer to [Section 13.7.9](#) for description of the interrupt registers.

13.4.8.1 Event Interrupts

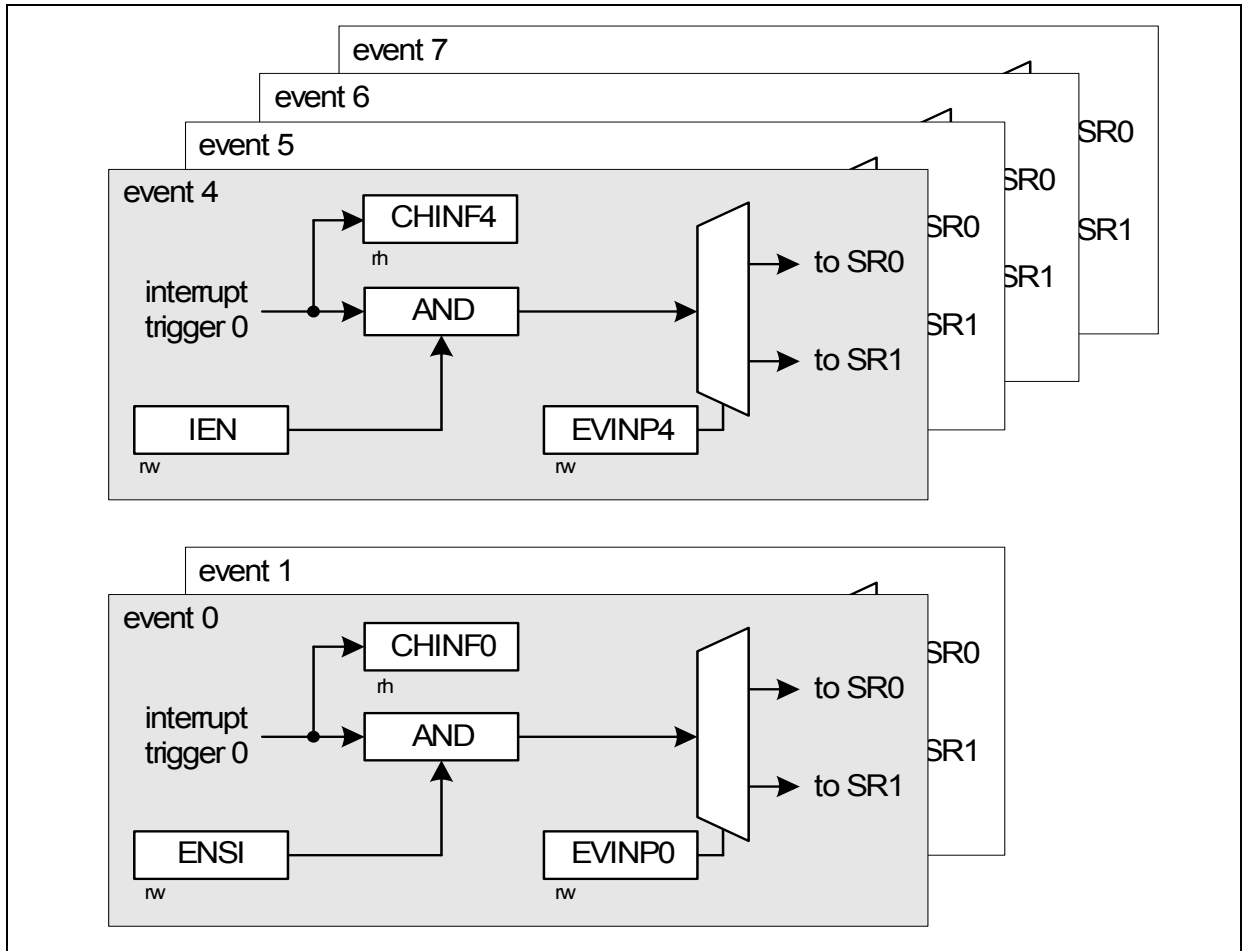

Figure 13-13 Event Interrupt Structure

Event interrupts can be generated by the request sources and the result registers. The event interrupt enable bits are located in the request sources (ENSI) and result register control (IEN). An interrupt node pointer (EVINP) for each event allows the selection of the targeted service output line.

A request source event is generated when the requested channel conversion is completed:

- Event 0: Request source event of sequential request source 0 (arbitration slot 0)
- Event 1: Request source event of parallel request source 1 (arbitration slot 1)

A result event is generated according to the data reduction control (see [Section 13.4.7.3](#)):

- Event 4: Result register event of result register 0
- Event 5: Result register event of result register 1
- Event 6: Result register event of result register 2
- Event 7: Result register event of result register 3

13.4.8.2 Channel Interrupts

The channel interrupts occur when a conversion is completed and the selected limit checking condition is met. As a result, only one channel interrupt can be activated at a time. An interrupt can be triggered according to the limit checking result by comparing the conversion result with two selectable boundaries for each channel.

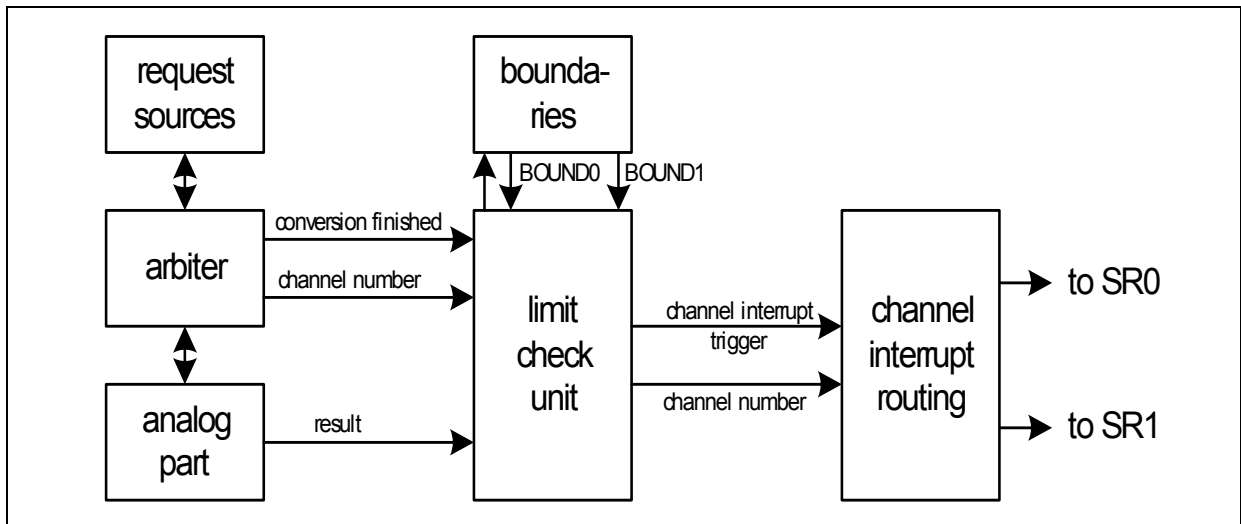

Figure 13-14 Channel Interrupt Overview

The limit checking unit uses two boundaries (BOUND0 and BOUND1) to compare with the conversion result. With these two boundaries, the conversion result space is split into three areas:

- Area I: The conversion result is below both boundaries.
- Area II: The conversion result is between the two boundaries.
- Area III: The conversion result is above both boundaries.

After a conversion has been completed, a channel interrupt can be triggered according to the following conditions (selected by the limit check control bit field LCC):

- LCC = 000: No trigger, the channel interrupt is disabled.
- LCC = 001: A channel interrupt is generated if the conversion result is not in area I.
- LCC = 010: A channel interrupt is generated if the conversion result is not in area II.
- LCC = 011: A channel interrupt is generated if the conversion result is not in area III.
- LCC = 100: A channel interrupt is always generated (regardless of the boundaries).
- LCC = 101: A channel interrupt is generated if the conversion result is in area I.
- LCC = 110: A channel interrupt is generated if the conversion result is in area II.
- LCC = 111: A channel interrupt is generated if the conversion result is in area III.

Analog-to-Digital Converter

The channel-specific interrupt node pointer CHINP_x (x = 0 to 7) selects the service request output (SR[1:0]) that will be activated upon a channel interrupt trigger. See **Figure 13-15**.

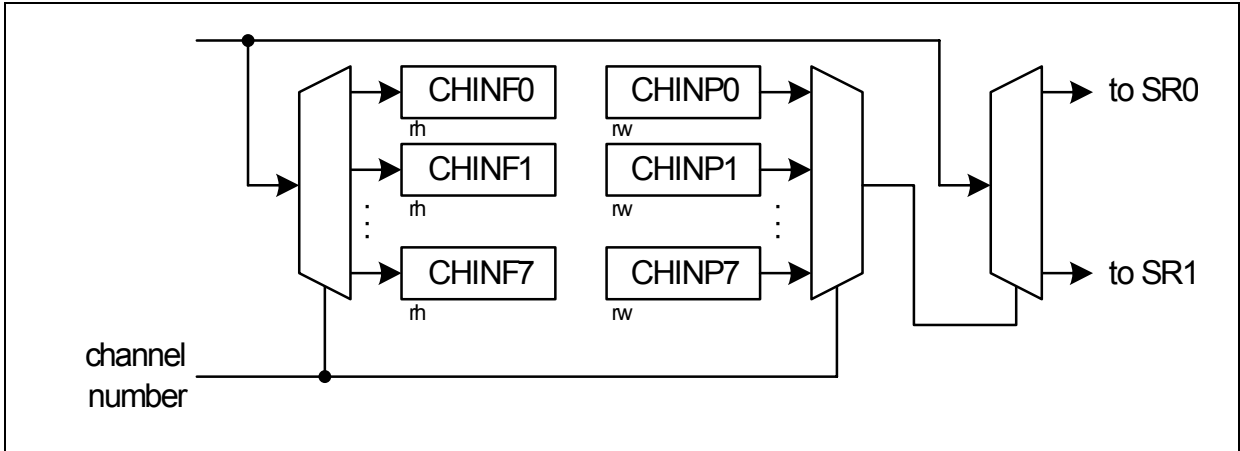

Figure 13-15 Channel Interrupt Routing

13.4.9 External Trigger Inputs

The sequential and parallel request sources has one request trigger input REQTRx (x = 0 - 1) each, through which a conversion request can be started. The input to REQTRx is selected from eight external trigger inputs (ETRx0 to ETRx7) via a multiplexer depending on bit field ETRSELx. It is possible to bypass the synchronization stages for external trigger requests that come synchronous to ADC. This selection is done via bit SYNENx.

Refer to [Section 13.7.9](#) for description of the external trigger control registers.

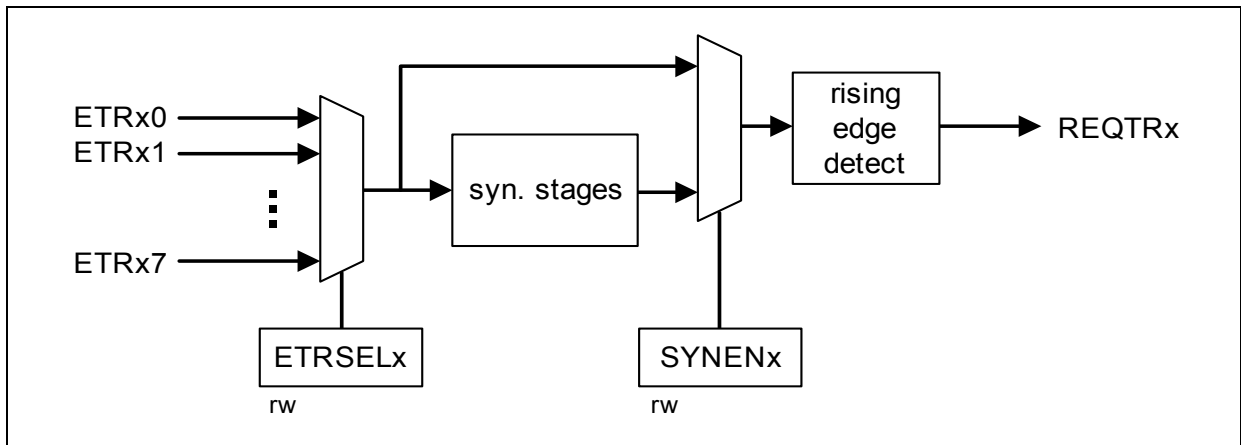

Figure 13-16 External Trigger Input

The external trigger inputs to the ADC module are driven by events occurring in the CCU6 module. See [Table 13-2](#).

Table 13-2 External Trigger Input Source

External Trigger Input	CCU6 Event
ETRx0	T13 period-match
ETRx1	T13 compare-match
ETRx2	T12 period-match
ETRx3	T12 compare-match for channel 0
ETRx4	T12 compare-match for channel 1
ETRx5	T12 compare-match for channel 2
ETRx6	Shadow transfer event for multi-channel mode
ETRx7	Correct hall event for multi-channel mode

13.5 ADC Module Initialization Sequence

The following steps is meant to provide a general guideline on how to initialize the ADC module. Some steps may be varied or omitted depending on the application requirements:

1. Configure global control functions:
 - Select conversion width (GLOBCTR.DW)
 - Select analog clock f_{ADC1} divider ratio (GLOBCTR.CTC)
2. Configure arbitration control functions:
 - Select request source x
 - priority (PRAR.PRIOx)
 - conversion start mode (PRAR.CSMx)
 - Enable arbitration slot x (PRAR.ASENx)
 - Select arbitration mode (PRAR.ARBM)
3. Configure channel control information:
 - Select channel x
 - limit check control (CHCTR_x.LCC)
 - target result register (CHCTR_x.RESRSEL)
 - Select sample time for all channels (INPCR0.STC)
4. Configure result control information:
 - Enable/disable result register x
 - data reduction (RCR_x.DRCTR)
 - event interrupt (RCR_x.IEN)
 - FIFO functionality (RCR_x.FEN)
 - wait-for-read mode (RCR_x.WFR)
 - valid flag reset by read access (RCR_x.VFCTR)
5. Configure interrupt control functions:
 - Select channel x interrupt node pointer (CHINPR.CHINP_x)
 - Select event x interrupt node pointer (CHINPR.EVINP_x)
6. Configure limit check boundaries:
 - Select limit check boundaries for all channels (LCBR.BOUND0, LCBR.BOUND1)
7. Configure external trigger control functions:
 - Select source x external trigger input (ETRCR.ETRSEL_x)
 - Enable/disable source x external trigger input synchronization (ETRCR.SYEN_x)
8. Setup sequential source:
 - Enable conversion request (QMR0.ENGT)
 - Enable/disable external trigger (QMR0.ENTR)
 - Select trigger mode (QMR0.TRMD)

9. Setup parallel source:

- Enable conversion request (CRMR1.ENGTT)
- Enable/disable external trigger (CRMR1.ENTR)
- Enable/disable source interrupt (CRMR1.ENSII)
- Enable/disable autoscan (CRMR1.SCAN)

10. Turn on analog part:

- Set GLOBCTR.ANON (wait for 100 ns)

11. Start sequential request:

- Write to QINR0 (with information such as REQCHNR, RF, ENSI and EXTR)
- Generate a pending conversion request using any method described in [Section 13.4.4.2](#)

12. Start parallel request:

- Write to CRCR1 (no load event) or CRPR1 (automatic load event) the channels to be converted.
- Generate a load event (if not already available) to trigger a pending conversion request, using any method described in [Section 13.4.5.2](#)

13. Wait for ADC conversion to be completed:

- The source interrupt indicates that the conversion requested by the source is completed.
- The channel interrupt indicates that the corresponding channel conversion is completed (with limit check performed).
- The result interrupt indicates that the result (with/without accumulation or FIFO) in the corresponding result register is ready and can be read.

14. Read ADC result

13.6 Register Map

The ADC SFRs are located in the standard memory area (RMAP = 0) and are organized into 7 pages. The ADC_PAGE register is located at address D1_H. It contains the page value and page control information.

ADC_PAGE

Page Register for ADC

Reset Value: 00_H

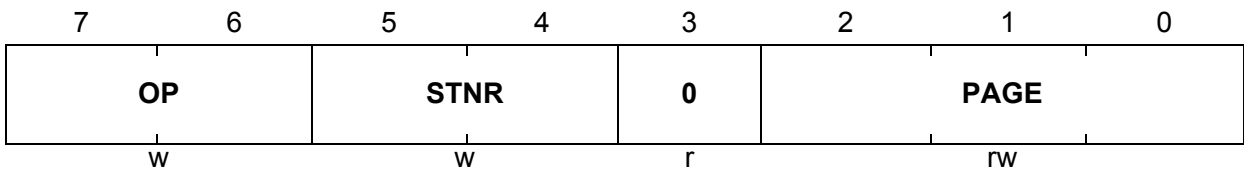

Field	Bits	Type	Description
PAGE	[2:0]	rw	<p>Page Bits</p> <p>When written, the value indicates the new page. When read, the value indicates the currently active page.</p>
STNR	[5:4]	w	<p>Storage Number</p> <p>This number indicates which storage bit field is the target of the operation defined by bit field OP. If OP = 10_B, the contents of PAGE are saved in STx before being overwritten with the new value. If OP = 11_B, the contents of PAGE are overwritten by the contents of STx. The value written to the bit positions of PAGE is ignored.</p> <p>00 ST0 is selected. 01 ST1 is selected. 10 ST2 is selected. 11 ST3 is selected.</p>

Analog-to-Digital Converter

Field	Bits	Type	Description
OP	[7:6]	w	<p>Operation</p> <p>0X Manual page mode. The value of STNR is ignored and PAGE is directly written.</p> <p>10 New page programming with automatic page saving. The value written to the bit positions of PAGE is stored. In parallel, the previous contents of PAGE are saved in the storage bit field STx indicated by STNR.</p> <p>11 Automatic restore page action. The value written to the bit positions of PAGE is ignored and instead, PAGE is overwritten by the contents of the storage bit field STx indicated by STNR.</p>
0	3	r	<p>Reserved</p> <p>Returns 0 if read, should be written with 0.</p>

Analog-to-Digital Converter

All ADC register names described in the following sections will be referenced in other chapters of this document with the module name prefix “ADC_”, e.g., ADC_GLOBCTR. The addresses of the ADC SFRs are listed in [Table 13-3](#) and [Table 13-4](#).

Table 13-3 SFR Address List for Pages 0-2

Address	Page 0	Page 1	Page 2
CA _H	GLOBCTR	CHCTR0	RESR0L
CB _H	GLOBSTR	CHCTR1	RESR0H
CC _H	PRAR	CHCTR2	RESR1L
CD _H	LCBR	CHCTR3	RESR1H
CE _H	INPCR0	CHCTR4	RESR2L
CF _H	ETRCR	CHCTR5	RESR2H
D2 _H	–	CHCTR6	RESR3L
D3 _H	–	CHCTR7	RESR3H

Table 13-4 SFR Address List for Pages 3-6

Address	Page 3	Page 4	Page 5	Page 6
CA _H	RESRA0L	RCR0	CHINFR	CRCR1
CB _H	RESRA0H	RCR1	CHINCR	CRPR1
CC _H	RESRA1L	RCR2	CHINSR	CRMR1
CD _H	RESRA1H	RCR3	CHINPR	QMR0
CE _H	RESRA2L	VFCR	EVINFR	QSR0
CF _H	RESRA2H	–	EVINCR	Q0R0
D2 _H	RESRA3L	–	EVINSR	QBUR0/QINR0
D3 _H	RESRA3H	–	EVINPR	–

13.7 Register Description

13.7.1 General Function Registers

Register GLOBCTR contains bits that control the analog converter and the conversion delay.

GLOBCTR

Global Control Register

Reset Value: 30_H

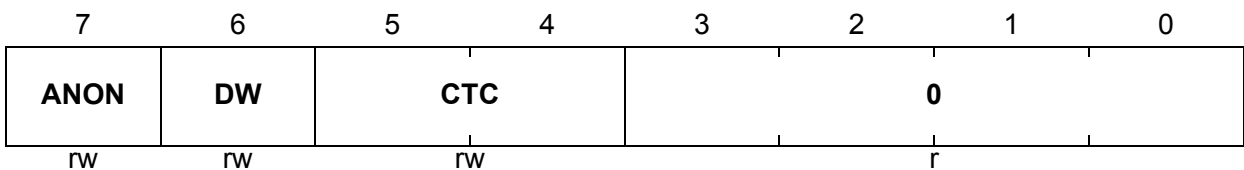

Field	Bits	Type	Description
CTC	[5:4]	rw	<p>Conversion Time Control This bit field defines the divider ratio for the divider stage of the internal analog clock f_{ADCI}. This clock provides the internal time base for the conversion and sample time calculations.</p> <p>00 $f_{ADCI} = 1/2 \times f_{ADCA}$ 01 $f_{ADCI} = 1/3 \times f_{ADCA}$ 10 $f_{ADCI} = 1/4 \times f_{ADCA}$ 11 $f_{ADCI} = 1/32 \times f_{ADCA}$ (default)</p>
DW	6	rw	<p>Data Width This bit defines the conversion resolution.</p> <p>0 The result is 10 bits wide (default). 1 The result is 8 bits wide.</p>
ANON	7	rw	<p>Analog Part Switched On This bit enables the analog part of the ADC module and defines its operation mode.</p> <p>0 The analog part is switched off and conversions are not possible. To achieve minimal power consumption, the internal analog circuitry is in its power-down state and the generation of f_{ADCI} is stopped.</p> <p>1 The analog part of the ADC module is switched on and conversions are possible. The automatic power-down capability of the analog part is disabled.</p>

Analog-to-Digital Converter

Field	Bits	Type	Description
0	[3:0]	r	Reserved Returns 0 if read; should be written with 0.

Register GLOBSTR contains bits that indicate the current status of a conversion.

GLOBSTR

Global Status Register

Reset Value: 00_H

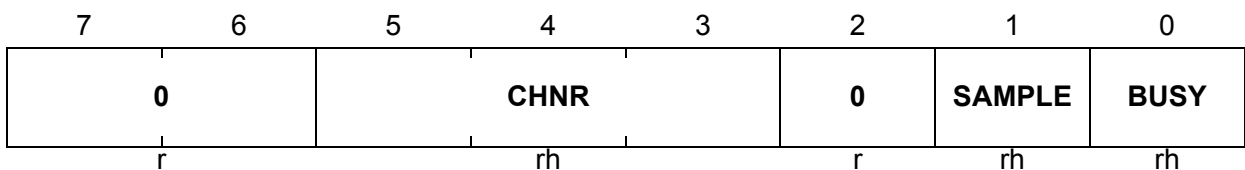

Field	Bits	Type	Description
BUSY	0	rh	Analog Part Busy This bit indicates that a conversion is currently active. 0 The analog part is idle. 1 A conversion is currently active.
SAMPLE	1	rh	Sample Phase This bit indicates that an analog input signal is currently sampled. 0 The analog part is not in the sampling phase. 1 The analog part is in the sampling phase.
CHNR	[5:3]	rh	Channel Number This bit field indicates which analog input channel is currently converted. This information is updated when a new conversion is started.
0	2, [7:6]	r	Reserved Returns 0 if read; should be written with 0.

13.7.2 Priority and Arbitration Register

Register PRAR contains bits that define the request source priority and the conversion start mode. It also contains bits that enable/disable the conversion request treatment in the arbitration slots.

PRAR

Priority and Arbitration Register

Reset Value: 00_H

7	6	5	4	3	2	1	0
ASEN1	ASEN0	0	ARBM	CSM1	PRI01	CSM0	PRI00
rw	rw	r	rw	rw	rw	rw	rw

Field	Bits	Type	Description
PRI00	0	rw	Priority of Request Source 0 This bit defines the priority of the sequential request source 0. 0 Low priority 1 High priority
CSM0	1	rw	Conversion Start Mode of Request Source 0 This bit defines the conversion start mode of the sequential request source 0. 0 The wait-for-start mode is selected. 1 The cancel-inject-repeat mode is selected.
PRI01	2	rw	Priority of Request Source 1 This bit defines the priority of the parallel request source 1. 0 Low priority 1 High priority
CSM1	3	rw	Conversion Start Mode of Request Source 1 This bit defines the conversion start mode of the parallel request source 1. 0 The wait-for-start mode is selected. 1 The cancel-inject-repeat mode is selected.
ARBM	4	rw	Arbitration Mode This bit defines which arbitration mode is selected. 0 Permanent arbitration (default) 1 Arbitration started by pending conversion request

Analog-to-Digital Converter

Field	Bits	Type	Description
ASENx (x = 0 - 1)	[7:6]	rw	<p>Arbitration Slot x Enable</p> <p>Each bit enables an arbitration slot of the arbiter round. ASEN0 enables arbitration slot 0, ASEN1 enables slot 1.</p> <p>If an arbitration slot is disabled, a pending conversion request of a request source connected to this slot is not taken into account for arbitration.</p> <p>0 The corresponding arbitration slot is disabled. 1 The corresponding arbitration slot is enabled.</p>
0	5	r	<p>Reserved</p> <p>Returns 0 if read; should be written with 0.</p>

13.7.3 External Trigger Control Register

Register ETRCR contains bits that select the external trigger input signal source and enable synchronization of the external trigger input.

ETRCR

External Trigger Control Register

Reset Value: 00_H

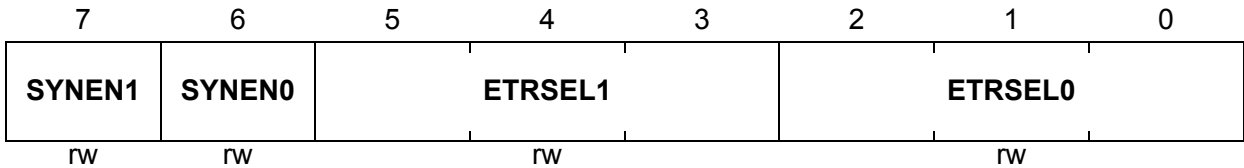

Field	Bits	Type	Description
ETRSEL_x (x = 0 - 1)	[2:0], [5:3]	rw	External Trigger Selection for Request Source x This bit field defines which external trigger input signal is selected. 000 The trigger input ETR _x 0 is selected. 001 The trigger input ETR _x 1 is selected. 111 The trigger input ETR _x 7 is selected.
SYNEN_x (x = 0 - 1)	6, 7	rw	Synchronization Enable 0 Synchronizing stage is not in external trigger input REQTR _x path. 1 Synchronizing stage is in external trigger input REQTR _x path.

13.7.4 Channel Control Registers

The channel control registers contain bits that select the targeted result register and control the limit check mechanism. Register CHCTR_x defines the settings for the input channel x.

CHCTR_x (x = 0 - 7)

Channel Control Register x

Reset Value: 00_H

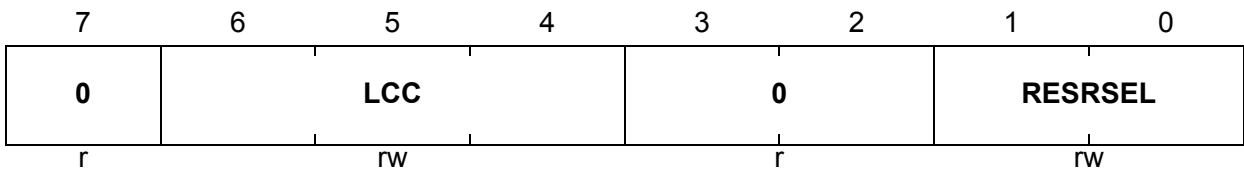

Field	Bits	Type	Description
RESRSEL	[1:0]	rw	Result Register Selection This bit field defines which result register will be the target of a conversion of this channel. 00 The result register 0 is selected. 01 The result register 1 is selected. 10 The result register 2 is selected. 11 The result register 3 is selected.
LCC	[6:4]	rw	Limit Check Control This bit field defines the behavior of the limit checking mechanism. See coding in Section 13.4.8.2 .
0	[3:2], 7	r	Reserved Returns 0 if read; should be written with 0.

13.7.5 Input Class Register

Register INPCR0 contains bits that control the sample time for the input channels.

INPCR0

Input Class 0 Register

Reset Value: 00_H

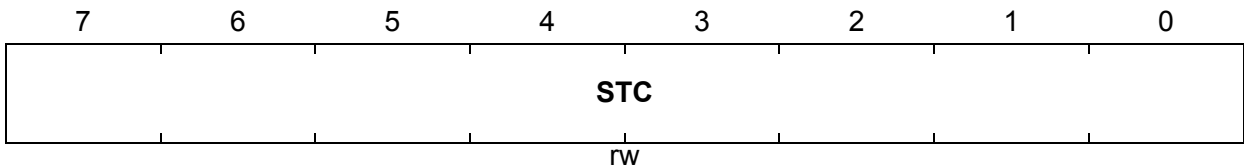

Field	Bits	Type	Description
STC	[7:0]	rw	<p>Sample Time Control</p> <p>This bit field defines the additional length of the sample time, given in terms of f_{ADCI} clock cycles. A sample time of 2 analog clock cycles is extended by the programmed value.</p>

13.7.6 Sequential Source Registers

These registers contain the control and status bits of sequential request source 0.

Register QMR0 contains bits that are used to set the sequential request source in the desired mode.

QMR0

Queue Mode Register

Reset Value: 00_H

7	6	5	4	3	2	1	0
CEV	TREV	FLUSH	CLRV	TRMD	ENTR	0	ENGT
w	w	w	w	rw	rw	r	rw

Field	Bits	Type	Description
ENGT	0	rw	<p>Enable Gate This bit enables the gating functionality for the request source.</p> <p>0 The gating line is permanently 0. The source is switched off.</p> <p>1 The gating line is permanently 1. The source is switched on.</p>
ENTR	2	rw	<p>Enable External Trigger This bit enables the external trigger possibility. If enabled, bit EV is set if a rising edge is detected at the external trigger input REQTR when at least one V bit is set in register Q0R0 or QBUR0.</p> <p>0 The external trigger is disabled.</p> <p>1 The external trigger is enabled.</p>
TRMD	3	rw	<p>Trigger Mode This bit defines which trigger mode is selected. In trigger mode 0, the output lines REQPNV and REQCHNRV can become active at the same time. In trigger mode 1, the signal REQPNV can become active before REQCHNRV.</p> <p>0 Trigger mode 0 is selected.</p> <p>1 Trigger mode 1 is selected.</p>
CLRV	4	w	<p>Clear V Bits</p> <p>0 No action</p> <p>1 The bit V in register Q0R0 or QBUR0 is reset. If QBUR0.V = 1, then QBUR0.V is reset. If QBUR0.V = 0, then Q0R0.V is reset.</p>

Analog-to-Digital Converter

Field	Bits	Type	Description
FLUSH	5	w	Flush Queue 0 No action 1 All bits V in the queue registers and bit EV are reset. The queue contains no more valid entry.
TREV	6	w	Trigger Event 0 No action 1 A trigger event is generated by software. If the source waits for a trigger event, a conversion request is started.
CEV	7	w	Clear Event Bit 0 No action 1 Bit EV is cleared.
0	1	r	Reserved Returns 0 if read; should be written with 0.

Analog-to-Digital Converter

Register QSR0 contains bits that indicate the status of the sequential source.

QSR0

Queue Status Register

Reset Value: 20_H

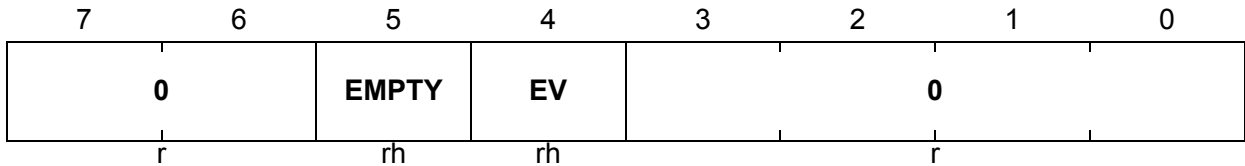

Field	Bits	Type	Description
EV	4	rh	<p>Event Detected This bit indicates that an event has been detected while V = 1. Once set, this bit is reset automatically when the requested conversion is started.</p> <p>0 An event has not been detected. 1 An event has been detected.</p>
EMPTY	5	rh	<p>Queue Empty This bit indicates if the queue (Q0R0) contains a valid entry. It is incremented each time a new entry is written to QINR0. It is decremented each time a conversion request from the queue is started. A new entry is ignored if the queue is filled (EMPTY = 0).</p> <p>0 The queue is filled (1 valid entry). 1 The queue is empty.</p>
0	[3:0], [7:6]	r	<p>Reserved Returns 0 if read; should be written with 0.</p>

Register Q0R0 contains bits that monitor the status of the current sequential request.

Q0R0

Queue 0 Register 0

Reset Value: 00_H

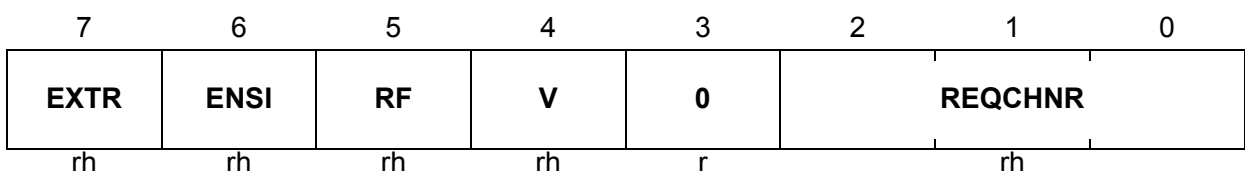

Analog-to-Digital Converter

Field	Bits	Type	Description
REQCHNR	[2:0]	rh	Request Channel Number This bit field indicates the channel number that will be or is currently requested.
V	4	rh	Request Channel Number Valid This bit indicates if the data in REQCHNR, RF, ENSI and EXTR is valid. Bit V is set when a valid entry is written to the queue input register QINR0 (or by an update by intermediate queue registers). 0 The data is not valid. 1 The data is valid.
RF	5	rh	Refill This bit indicates if the pending request is discarded after being executed (conversion start) or if it is automatically refilled in the top position of the request queue. 0 The request is discarded after conversion start. 1 The request is refilled in the queue after conversion start.
ENSI	6	rh	Enable Source Interrupt This bit indicates if a source interrupt will be generated when the conversion is completed. The interrupt trigger becomes activated if the conversion requested by the source has been completed and ENSI = 1. 0 The source interrupt generation is disabled. 1 The source interrupt generation is enabled.
EXTR	7	rh	External Trigger This bit defines if the conversion request is sensitive to an external trigger event. The event flag (bit EV) indicates if an external event has taken place and a conversion can be requested. 0 Bit EV not used to start conversion request. 1 Bit EV is used to start conversion request.
0	3	r	Reserved Returns 0 if read; should be written with 0.

Analog-to-Digital Converter

The registers QBUR0 and QINR0 share the same register address. A read operation at this register address will deliver the 'rh' bits of the QBUR0 register, while a write operation to the same address will target the 'w' bits of the QINR0 register.

Register QBUR0 contains bits that monitor the status of an aborted sequential request.

QBUR0
Queue Backup Register 0
Reset Value: 00_H

7	6	5	4	3	2	1	0
EXTR	ENSI	RF	V	0	REQCHNR		
rh	rh	rh	rh	r	rh		

Field	Bits	Type	Description
REQCHNR	[2:0]	rh	Request Channel Number This bit field is updated by bit field Q0R0.REQCHNR when the conversion requested by Q0Rs is started.
V	4	rh	Request Channel Number Valid This bit indicates if the data in REQCHNR, RF, ENSI, and EXTR is valid. Bit V is set if a running conversion is aborted. It is reset when the conversion is started. 0 The backup register does not contain valid data, because the conversion described by this data has not been aborted. 1 The data is valid. The aborted conversion is requested before taking into account what is requested by Q0R0.
RF	5	rh	Refill This bit is updated by bit Q0R0.RF when the conversion requested by Q0R0 is started.
ENSI	6	rh	Enable Source Interrupt This bit is updated by bit Q0R0.ENSI when the conversion requested by Q0R0 is started.
EXTR	7	rh	External Trigger This bit is updated by bit Q0R0.EXTR when the conversion requested by Q0R0 is started.
0	3	r	Reserved Returns 0 if read; should be written with 0.

Analog-to-Digital Converter

Register QINR0 is the entry register for sequential requests.

QINR0

Queue Input Register 0

Reset Value: 00_H

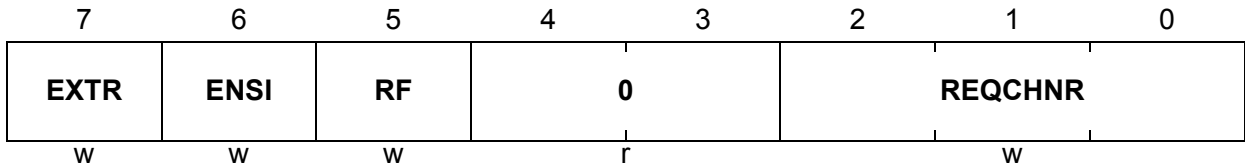

Field	Bits	Type	Description
REQCHNR	[2:0]	w	Request Channel Number This bit field defines the requested channel number.
RF	5	w	Refill This bit defines the refill functionality.
ENSI	6	w	Enable Source Interrupt This bit defines the source interrupt functionality.
EXTR	7	w	External Trigger This bit defines the external trigger functionality.
0	[4:3]	r	Reserved Returns 0 if read; should be written with 0.

13.7.7 Parallel Source Registers

These registers contain the control and status bits of parallel request source 1.

Register CRCR1 contains the bits that are copied to the pending register (CRPR1) when the load event occurs. This register can be accessed at two different addresses (one read view, two write views). The first address for read and write access is the address given for CRCR1. The second address for write actions is given for CRPR1. A write operation to CRPR1 leads to a data write to the bits in CRCR1 with an automatic load event one clock cycle later.

CRCR1

Conversion Request Control Register 1

Reset Value: 00_H

7	6	5	4	3	2	1	0
CH7	CH6	CH5	CH4	0			
rwh	rwh	rwh	rwh	r			

Field	Bits	Type	Description
CHx (x = 4 - 7)	x	rwh	<p>Channel Bit x</p> <p>Each bit corresponds to one analog channel, the channel number x is defined by the bit position in the register. The corresponding bit x in the conversion request pending register will be overwritten by this bit when the load event occurs.</p> <p>0 The analog channel x will not be requested for conversion by the parallel request source.</p> <p>1 The analog channel x will be requested for conversion by the parallel request source.</p>
0	[3:0]	r	<p>Reserved</p> <p>Returns 0 if read; should be written with 0.</p>

Analog-to-Digital Converter

Register CRPR1 contains bits that request a conversion of the corresponding analog channel. The bits in this register have only a read view. A write operation to this address leads to a data write to CRCR1 with an automatic load event one clock cycle later.

CRPR1

Conversion Request Pending Register 1

Reset Value: 00_H

7	6	5	4	3	2	1	0
CHP7	CHP6	CHP5	CHP4	0			
rwh	rwh	rwh	rwh				r

Field	Bits	Type	Description
CHPx (x = 4 - 7)	x	rwh	<p>Channel Pending Bit x</p> <p><u>Write view:</u> A write to this address targets the bits in register CRCR1.</p> <p><u>Read view:</u> Each bit corresponds to one analog channel; the channel number x is defined by the bit position in the register.</p> <p>The arbiter automatically resets (at start of conversion) or sets it again (at abort of conversion) for the corresponding analog channel.</p> <p>0 The analog channel x is not requested for conversion by the parallel request source.</p> <p>1 The analog channel x is requested for conversion by the parallel request source.</p>
0	[3:0]	r	<p>Reserved</p> <p>Returns 0 if read; should be written with 0.</p>

Note: The bits that can be read from this register location are generally ‘rh’. They cannot be modified directly by a write operation. A write operation modifies the bits in CRCR1 (that is why they are marked ‘rwh’) and leads to a load event one clock cycle later.

Analog-to-Digital Converter

Register CRMR1 contains bits that are used to set the request source in the desired mode.

CRMR1
Conversion Request Mode Register 1
Reset Value: 00_H

7	6	5	4	3	2	1	0
0	LDEV	CLRPND	SCAN	ENSI	ENTR	0	ENGT
r	w	w	rw	rw	rw	r	rw

Field	Bits	Type	Description
ENGT	0	rw	Enable Gate This bit enables the gating functionality for the request source. 0 The gating line is permanently 0. The source is switched off. 1 The gating line is permanently 1. The source is switched on.
ENTR	2	rw	Enable External Trigger This bit enables the external trigger possibility. If enabled, the load event takes place if a rising edge is detected at the external trigger input REQTR. 0 The external trigger is disabled. 1 The external trigger is enabled.
ENSI	3	rw	Enable Source Interrupt This bit enables the request source interrupt. This interrupt can be generated when the last pending conversion is completed for this source (while PND = 0). 0 The source interrupt is disabled. 1 The source interrupt is enabled.
SCAN	4	rw	Autoscan Enable This bit enables the autoscan functionality. If enabled, the load event is automatically generated when a conversion (requested by this source) is completed and PND = 0. 0 The autoscan functionality is disabled. 1 The autoscan functionality is enabled.

Analog-to-Digital Converter

Field	Bits	Type	Description
CLRPND	5	w	Clear Pending Bits 0 No action 1 The bits in register CRPR1 are reset.
LDEV	6	w	Generate Load Event 0 No action 1 The load event is generated.
0	1, 7	r	Reserved Returns 0 if read; should be written with 0.

13.7.8 Result Registers

The result registers deliver the conversion results and, optionally, the channel number that has lead to the latest update of the result register. The result registers are available as different read views at different addresses. The following bit fields can be read from the result registers, depending on the selected read address. For details on the conversion result alignment and width, see [Section 13.4.7.5](#).

Field	Bits	Type	Description
RESULT	RESR _x L[7:6], RESR _x H or RESR _A _x L[7:5], RESR _A _x H	rh	Conversion Result This bit field contains the conversion result or the result of the data reduction filter.
CHNR	[2:0]	rh	Channel Number This bit field contains the channel number of the latest register update.
DRC	3	rh	Data Reduction Counter This bit indicates how many conversion results have still to be accumulated to generate the final result for data reduction. 0 The final result is available in the result register. The valid flag is automatically set when this bit field is set to 0. 1 One more conversion result must be added to obtain the final result in the result register. The valid flag is automatically reset when this bit field is set to 1.
VF	4	rh	Valid Flag for Result Register x This bit indicates that the contents of the result register x are valid. 0 The result register x does not contain valid data. 1 The result register x contains valid data.

Normal Read View RESRx

This view delivers the 8-bit or 10-bit conversion result and a 3-bit channel number. The corresponding valid flag is cleared when the high byte of the register is accessed by a read command, provided that bit RCRx.VFCR is set.

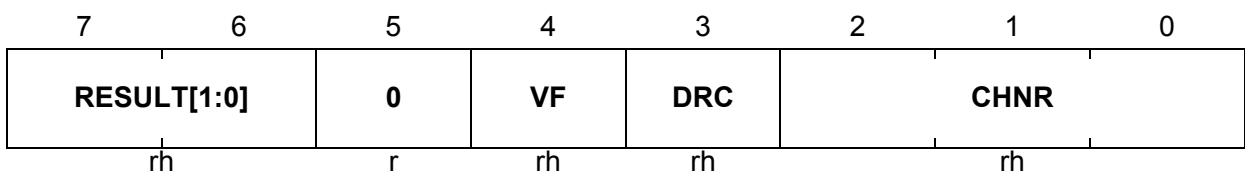
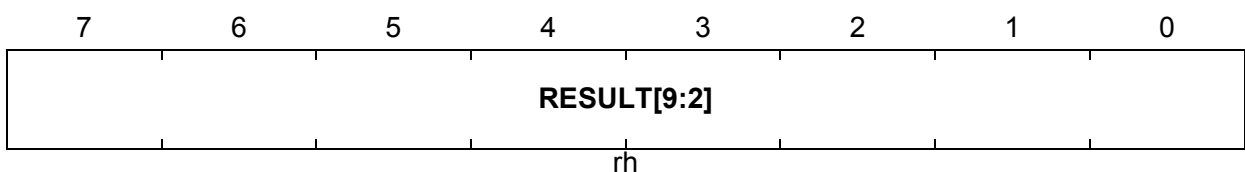
RESRxL (x = 0 - 3)
Result Register x Low
Reset Value: 00_H

RESRxH (x = 0 - 3)
Result Register x High
Reset Value: 00_H

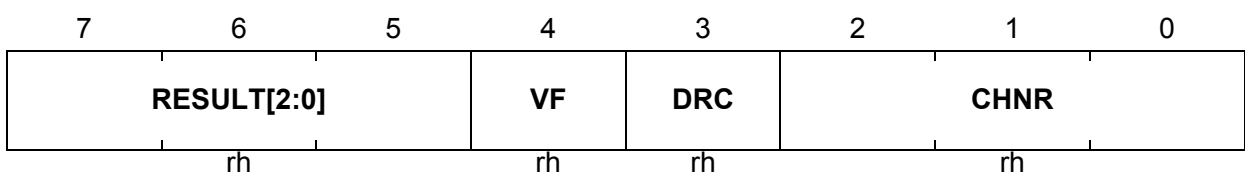
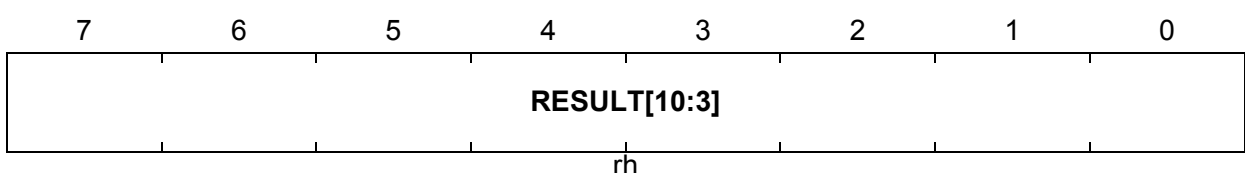
Accumulated Read View RESRAx

This view delivers the accumulated 9-bit or 11-bit conversion result and a 3-bit channel number. The corresponding valid flag is cleared when the high byte of the register is accessed by a read command, provided that bit RCRx.VFCR is set.

RESRAxL (x = 0 - 3)
Result Register x, View A Low
Reset Value: 00_H

RESRAxH (x = 0 - 3)
Result Register x, View A High
Reset Value: 00_H

Analog-to-Digital Converter

Writing a 1 to a bit position in register VF_{CR} clears the corresponding valid flag in registers RESR_x/RESR_{Ax}. If a hardware event triggers the setting of a bit VF_x and VF_{Cx} = 1, the bit VF_x is cleared (software overrules hardware).

VF_{CR}

Valid Flag Clear Register

Reset Value: 00_H

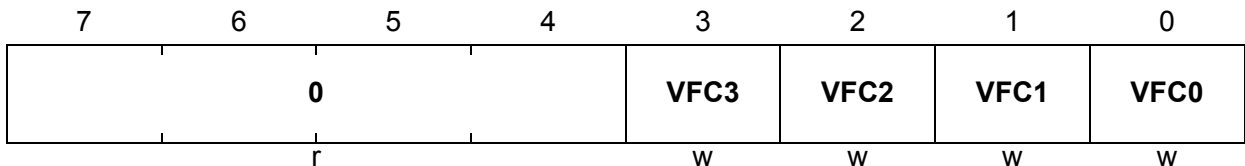

Field	Bits	Type	Description
VF_{Cx} (x = 0 - 3)	x	w	Clear Valid Flag for Result Register x 0 No action 1 Bit VFR.x is reset.
0	[7:4]	r	Reserved Returns 0 if read; should be written with 0.

The result control registers RCR_x contain bits that control the behavior of the result registers and monitor their status.

RCR_x (x = 0 - 3)

Result Control Register x

Reset Value: 00_H

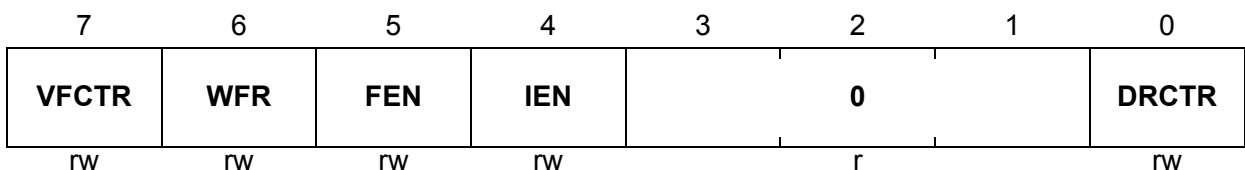

Analog-to-Digital Converter

Field	Bits	Type	Description
DRCTR	0	rw	Data Reduction Control This bit defines how many conversion results are accumulated for data reduction. It defines the reload value for bit DRC. 0 The data reduction filter is disabled. The reload value for DRC is 0, so the accumulation is done over 1 conversion. 1 The data reduction filter is enabled. The reload value for DRC is 1, so the accumulation is done over 2 conversions.
IEN	4	rw	Interrupt Enable This bit enables the event interrupt related to the result register x. An event interrupt can be generated when DRC is set to 0 (after decrementing or by reload). 0 The event interrupt is disabled. 1 The event interrupt is enabled.
FEN	5	rw	FIFO Enable This bit enables the FIFO functionality for result register x. 0 The FIFO functionality is disabled. 1 The FIFO functionality is enabled.
WFR	6	rw	Wait-for-Read Mode This bit enables the wait-for-read mode for result register x. 0 The wait-for-read mode is disabled. 1 The wait-for-read mode is enabled.
VFCTR	7	rw	Valid Flag Control This bit enables the reset of valid flag (by read access to high byte) for result register x. 0 VF unchanged by read access to RESR _x H/ RESR _A xH. (default) 1 VF reset by read access to RESR _x H/ RESR _A xH.
0	[3:1]	r	Reserved Returns 0 if read; should be written with 0.

13.7.9 Interrupt Registers

Register CHINFR monitors the activated channel interrupt flags.

CHINFR

Channel Interrupt Flag Register

Reset Value: 00_H

7	6	5	4	3	2	1	0
CHINF7	CHINF6	CHINF5	CHINF4	CHINF3	CHINF2	CHINF1	CHINF0
rh	rh	rh	rh	rh	rh	rh	rh

Field	Bits	Type	Description
CHINF_x (x = 0 - 7)	x	rh	Interrupt Flag for Channel x This bit monitors the status of the channel interrupt x. 0 A channel interrupt for channel x has not occurred. 1 A channel interrupt for channel x has occurred.

Writing a 1 to a bit position in register CHINCR clears the corresponding channel interrupt flag in register CHINFR. If a hardware event triggers the setting of a bit CHINF_x and CHINC_x = 1, the bit CHINF_x is cleared (software overrules hardware).

CHINCR

Channel Interrupt Clear Register

Reset Value: 00_H

7	6	5	4	3	2	1	0
CHINC7	CHINC6	CHINC5	CHINC4	CHINC3	CHINC2	CHINC1	CHINC0
w	w	w	w	w	w	w	w

Field	Bits	Type	Description
CHINC_x (x = 0 - 7)	x	w	Clear Interrupt Flag for Channel x 0 No action 1 Bit CHINFR.x is reset.

Analog-to-Digital Converter

Writing a 1 to a bit position in register CHINSR sets the corresponding channel interrupt flag in register CHINFR and generates an interrupt pulse.

CHINSR
Channel Interrupt Set Register
Reset Value: 00_H

7	6	5	4	3	2	1	0
CHINS7	CHINS6	CHINS5	CHINS4	CHINS3	CHINS2	CHINS1	CHINS0
W	W	W	W	W	W	W	W

Field	Bits	Type	Description
CHINSx (x = 0 - 7)	x	w	Set Interrupt Flag for Channel x 0 No action 1 Bit CHINFR.x is set and an interrupt pulse is generated.

The bits in register CHINPR define the service request output line, SRx (x = 0 or 1), that is activated if a channel interrupt is generated.

CHINPR
Channel Interrupt Node Pointer Register
Reset Value: 00_H

7	6	5	4	3	2	1	0
CHINP7	CHINP6	CHINP5	CHINP4	CHINP3	CHINP2	CHINP1	CHINP0
rw	rw	rw	rw	rw	rw	rw	rw

Field	Bits	Type	Description
CHINPx (x = 0 - 7)	x	rw	Interrupt Node Pointer for Channel x This bit defines which SR lines becomes activated if the channel x interrupt is generated. 0 The line SR0 becomes activated. 1 The line SR1 becomes activated.

Analog-to-Digital Converter

Register EVINFR monitors the activated event interrupt flags.

EVINFR
Event Interrupt Flag Register
Reset Value: 00_H

7	6	5	4	3	2	1	0
EVINF7	EVINF6	EVINF5	EVINF4	0	0	EVINF1	EVINF0
rh	rh	rh	rh	r	r	rh	rh

Field	Bits	Type	Description
EVINF_x (x = 0 - 1, 4 - 7)	[1:0], [7:4]	rh	Interrupt Flag for Event x This bit monitors the status of the event interrupt x. 0 An event interrupt for event x has not occurred. 1 An event interrupt for event x has occurred.
0	[3:2]	r	Reserved Returns 0 if read; should be written with 0.

Writing a 1 to a bit position in register EVINCR clears the corresponding event interrupt flag in register EVINFR. If a hardware event triggers the setting of a bit EVINF_x and EVINC_x = 1, the bit EVINF_x is cleared (software overrules hardware).

EVINCR
Event Interrupt Clear Flag Register
Reset Value: 00_H

7	6	5	4	3	2	1	0
EVINC7	EVINC6	EVINC5	EVINC4	0	0	EVINC1	EVINC0
w	w	w	w	r	r	w	w

Field	Bits	Type	Description
EVINC_x (x = 0 - 1, 4 - 7)	[1:0], [7:4]	w	Clear Interrupt Flag for Event x 0 No action 1 Bit EVINFR.x is reset.
0	[3:2]	r	Reserved Returns 0 if read; should be written with 0.

Analog-to-Digital Converter

Writing a 1 to a bit position in register EVINSR sets the corresponding event interrupt flag in register EVINFR and generates an interrupt pulse (if the interrupt is enabled).

EVINSR
Event Interrupt Set Flag Register
Reset Value: 00_H

7	6	5	4	3	2	1	0
EVINS7	EVINS6	EVINS5	EVINS4	0	EVINS1	EVINS0	
w	w	w	w	r	w	w	

Field	Bits	Type	Description
EVINSx (x = 0 - 1, 4 - 7)	[1:0], [7:4]	w	Set Interrupt Flag for Event x 0 No action 1 Bit EVINFR.x is set.
0	[3:2]	r	Reserved Returns 0 if read; should be written with 0.

The bits in register EVINPR define the service request output line, SRx (x = 0 or 1), that is activated if an event interrupt is generated.

EVINPR
Event Interrupt Node Pointer Register
Reset Value: 00_H

7	6	5	4	3	2	1	0
EVINP7	EVINP6	EVINP5	EVINP4	0	EVINP1	EVINP0	
rw	rw	rw	rw	r	rw	rw	

Field	Bits	Type	Description
EVINPx (x = 0 - 1, 4 - 7)	[1:0], [7:4]	rw	Interrupt Node Pointer for Event 0 This bit defines which SR lines becomes activated if the event 0 interrupt is generated. 0 The line SR0 becomes activated. 1 The line SR1 becomes activated.
0	[3:2]	r	Reserved Returns 0 if read; should be written with 0.

Analog-to-Digital Converter

The bit fields in register LCBR define the four MSB of the compare values (boundaries) used by the limit checking unit. The values defined in bit fields BOUND0 and BOUND1 are concatenated with either four (8-bit conversion) or six (10-bit conversion) 0s at the end to form the final value used for comparison with the converted result. For example, the reset value of BOUND1 (B_H) will translate into B0_H for an 8-bit comparison, and 2C0_H for a 10-bit comparison.

LCBR

Limit Check Boundary Register

Reset Value: B7_H

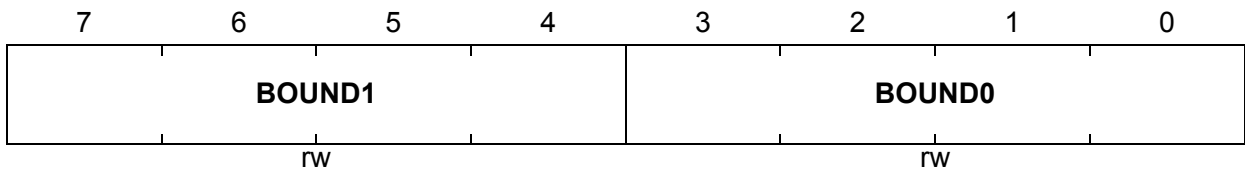

Field	Bits	Type	Description
BOUNDx (x = 0 - 1)	[3:0], [7:4]	rw	Boundary for Limit Checking This bit field defines the four MSB of the compare value used by the limit checking unit. The result of the limit check is used for interrupt generation.

14 On-Chip Debug Support

The On-Chip Debug Support (OCDS) provides the basic functionality required for the software development and debugging of XC800-based systems.

The OCDS design is based on these principles:

- use the built-in debug functionality of the XC800 Core
- add a minimum of hardware overhead
- provide support for most of the operations by a Monitor Program
- use standard interfaces to communicate with the Host (a Debugger)

Features:

- Set breakpoints on instruction address and within a specified address range
- Set breakpoints on internal RAM address
- Support unlimited software breakpoints in Flash/RAM code region
- Process external breaks
- Step through the program code

14.1 Functional Description

The OCDS functional blocks are shown in **Figure 14-1**. The Monitor Mode Control (MMC) block at the center of OCDS system brings together control signals and supports the overall functionality. The MMC communicates with the XC800 Core, primarily via the Debug Interface, and also receives reset and clock signals. After processing memory address and control signals from the core, the MMC provides proper access to the dedicated extra-memories: a Monitor ROM (holding the code) and a Monitor RAM (for work-data and Monitor-stack). The OCDS system is accessed through the JTAG¹⁾, which is an interface dedicated exclusively for testing and debugging activities and is not normally used in an application. The dedicated MBC pin is used for external configuration and debugging control.

Note: All the debug functionality described here can normally be used only after XC866 has been started in OCDS mode.

*Note: For more information on boot configuration options, see **Chapter 7.2.3**.*

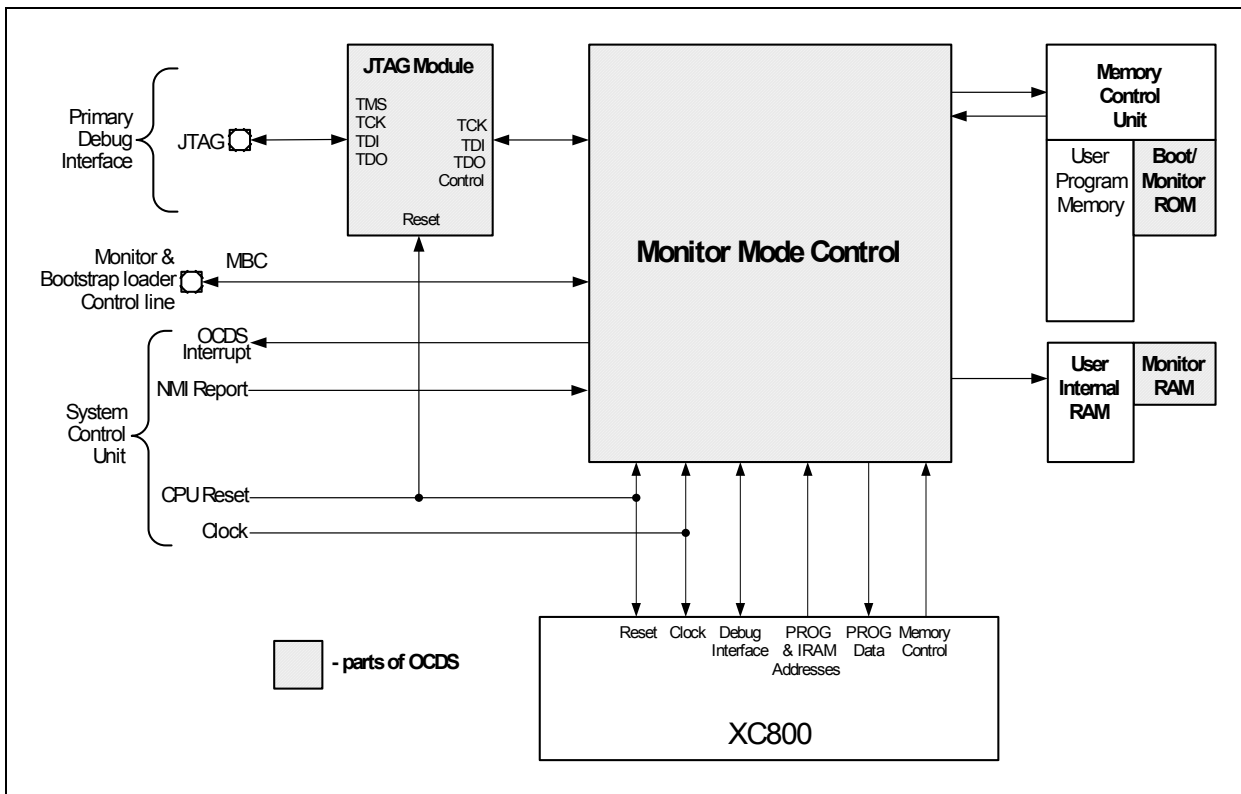

Figure 14-1 XC866 OCDS: Block Diagram

¹⁾ The pins of the JTAG port can be assigned to either Port 0 (primary) or Ports 1 and 2 (secondary). User must set the JTAG pins (TCK and TDI) as input during connection with the OCDS system.

14.2 Debugging

The on-chip debug system can be described in two parts. The first part covers the generation of Debug Events and the second part describes the Debug Actions that are taken when a debug event is generated.

- Debug events:
 - **Hardware Breakpoints**
 - **Software Breakpoints**
 - **External Breaks**
- Debug event actions:
 - **Call the Monitor Program**
 - **Activate the MBC pin**

The XC866 debug operation is based on close interaction between the OCDS hardware and a specialized software called the Monitor program.

14.2.1 Debug Events

The OCDS system recognizes a number of different debug events, which are also called breakpoints or simply breaks.

Depending on how the break events are processed in time, they can be classified into three types of breakpoints:

- Break Before Make
The break happens just before the break instruction, i.e. the instruction causing the break, is executed. Therefore, the break instruction itself will be the next instruction from the user program flow but executed only after the relevant debug action has been taken.
- Break After Make
The break happens immediately after the break instruction causing it has been executed. Therefore, the break instruction itself has already been executed when the relevant debug action is taken.
- Break Now
The events of this type are asynchronous to the code execution inside the XC866 and there is no “instruction causing the debug event” in this case. The debug action is performed by OCDS “as soon as possible” once the debug event is raised.

14.2.1.1 Hardware Breakpoints

Hardware breakpoints are generated by observing certain address buses within the XC866 system. The bus relevant to the hardware breakpoint type is continuously compared against certain registers where addresses for the breakpoints have been programmed.

The hardware breakpoints can be classified under two types:

- depending on the address bus supervised
 - **Breakpoints on Instruction Address**
Program Memory Address (PROGA) is observed
 - **Breakpoints on IRAM Address**
Internal Data Memory Addresses (SOURCE_A, DESTIN_A) are observed
- depending on the way comparison is done
 - Equal breakpoints
Comparison is done only against one value; the break event is raised when only this value is matched.
 - Range breakpoints
Comparison is done against two values; the break event is raised when a value observed is found belonging to the range between two programmed values (inclusively).

Breakpoints on Instruction Address

These Instruction Pointer (IP) breakpoints are generated when a break address is matched for the first byte of an instruction that is going to be executed i.e., for the address within Program Memory where an instruction opcode is to be fetched from.

Note: In the cases of 2- and 3-byte instructions, the break will not be generated for addresses of the second and third instruction bytes.

If the IP breakpoints are of the Break Before Make type, the instruction at the breakpoint will be executed only after the proper debug action is taken.

The OCDS in XC866 supports both equal breakpoints and range breakpoints on Instruction address (see **“Configurations of Hardware Breakpoints” on Page 14-5**).

Breakpoints on IRAM Address

These breakpoints are generated when a break address is matched with the address from the Internal Data Memory (IRAM), to which location an instruction performs read or write access.

The IRAM breakpoints are of the Break After Make type; the proper debug action is taken immediately after the operation to the breakpoint address is already performed.

The OCDS in XC866 supports only range breakpoints on IRAM address.

When the Internal Data Memory is RAM, the OCDS differentiates between a breakpoint on read and a breakpoint on write operation to this IRAM.

Configurations of Hardware Breakpoints

The OCDS in XC866 allows the setting of up to 4 hardware breakpoints labeled HWBP_x (x = 0 - 3) (16-bit values) in various configurations as follows:

- **HWBP0**
- **HWBP1**
 - two **equal** breakpoints on **Instruction Address=HWBP0** and **Instruction Address=HWBP1**, or
 - one **range** breakpoint on **HWBP0 <= Instruction Address <= HWBP1**
- **HWBP2**
 - one **equal** breakpoint on **Instruction Address=HWBP2**, or
 - one **range** breakpoint on **HWBP2L <= IRAM Read Address <= HWBP2H**
- **HWBP3**
 - one **equal** breakpoint on **Instruction Address=HWBP3**, or
 - one **range** breakpoint on **HWBP3L <= IRAM Write Address <= HWBP3H**

In XC866, the Program Memory address is 16-bit wide, while the Internal Data Memory addresses (both for Read and Write) are 8-bit wide. This is why the complete HWBP2 and HWBP3 values are used to generate IP breakpoints, while the low and high bytes HWBP_xL and HWBP_xH (x = 2 - 3) are used separately to generate IRAM breakpoints.

Setting both the values to the same address for a range breakpoint leads to generation of an equal breakpoint.

14.2.1.2 Software Breakpoints

These breakpoints use the XC800-specific (not 8051-standard) TRAP instruction, decoded by the core while at the same time the TRAP_EN bit within the Extended Operation (EO) register is set to 1.

Upon fetching a TRAP instruction, a Break Before Make breakpoint is generated and the relevant Break Action is taken.

The software breakpoints are in fact similar in behavior to the equal breakpoints on Instruction address, except that they are raised by a program code instead of specialized (compare) logic.

An unlimited number of software breakpoints can be set by replacing the original instruction opcodes in the user program. However, this is possible only at addresses where a writable memory (RAM/Flash) is implemented.

Note: In order to continue user program execution after the debug event, an external Debugger must restore the original opcode at the address of the current software breakpoint.

14.2.1.3 External Breaks

These debug events are of the Break Now type and can be raised in two ways:

- by a request via the JTAG interface; using a special sequence, an external device connected to the JTAG can break a user program running on the XC866 and start a debug session.
- by asserting low the dedicated Monitor and BootStrap loader Control line (MBC) while the XC866 is running; used for reaction to asynchronous events from the external world.

14.2.2 Debug Actions

In case of a debug event, the OCDS system can respond in two ways depending on the current configuration.

14.2.2.1 Call the Monitor Program

XC866 comes with an on-chip Monitor program, factory-stored into the non-volatile Monitor ROM (see [Figure 14-1](#)). Activating this program is the primary and basic OCDS reaction to recognized debug events.

The OCDS hardware ensures that the Monitor is always safely started, and fully independent of the current system status at the moment the debug action is taken. Also, additional interrupt requests raised meanwhile will not disturb the Monitor's functioning.

Once started, the Monitor runs with own stack- and data-work memory (see Monitor RAM in [Figure 14-1](#)), which guarantees that all of the core and memory resources will be found untouched when returning control back to the user program.

The functions of the XC866 Monitor include:

- communication with an external Debugger via the JTAG interface
- read/write access to arbitrary memory locations and Special Function Registers (SFRs), including the Instruction Pointer
- configuring OCDS and setting/removing breakpoints
- executing single instruction (step-mode)

Note: Detailed descriptions of the Monitor program functionality and the JTAG communication protocol are not provided in this document.

14.2.2.2 Activate the MBC pin

The MBC pin can be driven actively low by OCDS in reaction to debug events.

This functionality allows two alternative configurations:

- as an action additional to the Monitor program start
- as the only OCDS response while temporarily (for 4 SCLK clock cycles) suspending the core activity; this is the fastest reaction to the external world

14.3 Register Description

From the programmer's point of view, OCDS is represented by a total of 8 register-addresses (see [Table 14-1](#)), all located within the mapped SFR area.

Table 14-1 OCDS Directly Addressable Registers

Register Short Name	Address (mapped)	Register Full Name
MMCR	F1 _H	Monitor Mode Control Register
MMSR	F2 _H	Monitor Mode Status Register
MMBPCR	F3 _H	Monitor Mode Breakpoints Control Register
MMICR	F4 _H	Monitor Mode Interrupt Control Register
MMCR2	E9 _H	Monitor Mode Control Register 2
MMDR	F5 _H	Monitor Mode Data Register
HWBPSR	F6 _H	Hardware Breakpoints Select Register
HWBPDR	F7 _H	Hardware Breakpoints Data Register

Additionally, there are 8 Hardware Breakpoint registers, which are accessible indirectly via HWBPSR and HWBPDR (see [Table 14-2](#)).

Table 14-2 OCDS Indirectly Accessible Registers

Register Short Name	Register Full Name
HWBP0L	Hardware Breakpoint 0 Low Register
HWBP0H	Hardware Breakpoint 0 High Register
HWBP1L	Hardware Breakpoint 1 Low Register
HWBP1H	Hardware Breakpoint 1 High Register
HWBP2L	Hardware Breakpoint 2 Low Register
HWBP2H	Hardware Breakpoint 2 High Register
HWBP3L	Hardware Breakpoint 3 Low Register
HWBP3H	Hardware Breakpoint 3 High Register

Note: The OCDS registers are dedicated primarily to the on-chip Monitor program, and the user is strongly advised not to access them, as this can cause an unexpected behavior of the system.

Register Description

The Hardware Breakpoint registers can be used for general purposes only if the XC866 is not started in OCDS mode and no external device is connected to the JTAG interface. See [Table 14-1](#), [Table 14-2](#) and the description below.

HWBPSR

Hardware Breakpoints Select Register mapped SFR (F6_H) **Reset value: 00_H**

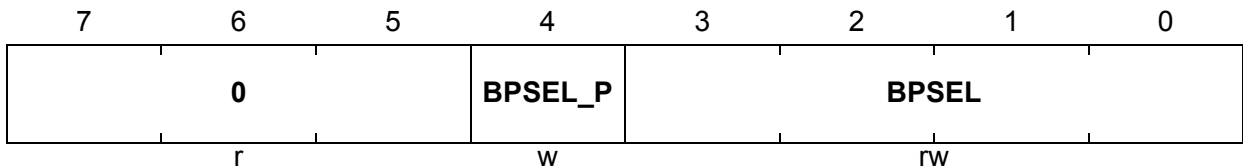

Field	Bits	Type	Description
BPSEL	[3:0]	rw	BreakPoint Register Select
BPSEL_P	4	w	Bit Protection 0 BPSEL unchangeable 1 BPSEL can be changed
0	[7:5]	r	Reserved Returns 0 if read; should be written with 0.

Table 14-3 HWBPSR [3:0]: Selecting Hardware Breakpoint Registers

BPSEL	Register Selected	BPSEL	Register Selected
0xxx	Reserved	—	—
1000	HWBP0L	1001	HWBP0H
1010	HWBP1L	1011	HWBP1H
1100	HWBP2L	1101	HWBP2H
1110	HWBP3L	1111	HWBP3H

HWBPDR

Hardware Breakpoints Data Register mapped SFR (F7_H) **Reset Value: 00_H**

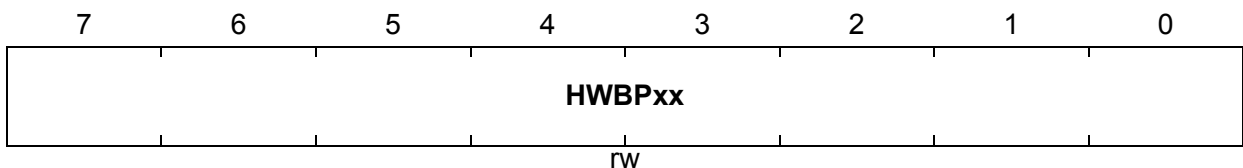

Field	Bits	Type	Description
HWBPxx	[7:0]	rw	Data to be written into/read from a HWBPxx register, as currently selected by HWBPSR (see Table 14-3)

14.3.1 JTAG ID Register

This is a read-only register located inside the JTAG module, and is used to recognize the device(s) connected to the JTAG interface. Its content is shifted out when INSTRUCTION register contains the IDCODE command (opcode 04_H), and the same is also true immediately after reset.

The JTAG ID register contents for the XC866 Flash devices are given in [Table 14-4](#).

Table 14-4 JTAG ID Summary

Device Type	Device Name	JTAG ID
Flash	XC866L-4FR	1010 0083 _H
	XC866-4FR	100F 5083 _H
	XC866L-2FR	1010 2083 _H
	XC866-2FR	1010 1083 _H

15 Index

15.1 Keyword Index

This section lists a number of keywords which refer to specific details of the XC866 in terms of its architecture, its functional units, or functions.

A

- Accumulator 2-4
- Alternate functions 6-10
 - Input 6-10
 - Output 6-3, 6-10
- Analog input clock 13-3
- Analog-to-Digital Converter 13-1
 - Interrupt 13-21
 - Channel 13-23
 - Event 13-22
 - Node pointer 13-24
 - Low power mode 13-7
 - Module clock 13-3
 - Register description 13-31
 - Register map 13-28
- Arbitration round 13-9
- Arbitration slot 13-9
- Arithmetic 2-2
- Asynchronous modes 10-2
- Automatic refill 13-11
- Autoscan 13-15

B

- Baud rate 10-11
 - Baud rate clock 10-11
 - Baud rate generation 10-26
 - Baud-rate generator 10-10
- Bit protection scheme 3-12
- Bitaddressable 3-9
- Boot options 7-6
 - BSL mode 7-6
 - OCDS mode 7-6
 - User mode 7-6

- Boot ROM 3-1
- Boot ROM operating mode 3-26
 - BootStrap Loader Mode 3-27
 - OCDS mode 3-27
 - User mode 3-26
- Bootling scheme 7-6
- BootStrap Loader 3-27, 4-6, 4-9
- Brownout reset 7-5
- Buffer mechanism 4-4

C

- Cancel-Inject-Repeat 13-10
- Capture/Compare Unit 6 12-1
 - Register description 12-29
 - Register map 12-28
- Central Processing Unit 2-1
- Circular stack memory 4-4
- Clock source 7-11
- Clock system 7-9
- Continuous transfer operation 10-25
- Conversion error 13-4
- Conversion phase 13-5
- Correction algorithm 4-8
- CPU 2-1

D

- Data Flash 4-2, 4-3
- Data memory 3-3
- Data pointer 2-4
- Data reduction 13-17
 - Counter 13-18
- Debug 14-3
 - Events 14-3

D-Flash 4-2, 4-3
Digital input clock 13-3
Direct drive 7-11
Direct feed-through 6-4
Document
 Acronyms 1-14
 Terminology 1-13
 Textual convention 1-12
Dynamic error detection 4-8

E

EEPROM emulation 4-4
Embedded voltage regulator 7-1
 Features 7-2
 Low power voltage regulator 7-2
 Main voltage regulator 7-2
 Threshold voltage levels 7-2
Error Correction Code 4-8
Extended operation 2-6
External breaks 14-6
 Break now 14-6
External data memory 3-3
External oscillator 7-9, 7-11

F

Flash 4-1
 Endurance 4-4
 Erase mode 4-7
 Non-volatile 4-1
 Operating modes 4-7
 Power-down mode 4-7
 Program mode 4-7
 Program width 4-6
 Ready-to-read mode 4-7
 Sector 4-3
Flash devices 3-1
Flash program memory 3-1
Flash Timer NMI 4-11
Full-duplex operation 10-21

G

Gate disturb 4-6
GPIO 6-1, 6-6

H

Half-duplex operation 10-24
Hall sensor mode
 Actual hall pattern 12-19
 Block commutation 12-21
 Brushless-DC 12-19, 12-20
 Correct hall event 12-19
 Expected Hall pattern 12-19
 Hall pattern 12-19
 Modulation pattern 12-19
 Noise filter 12-19
Hamming code 4-8
Hardware breakpoints 14-4
Hardware reset 7-4
High-impedance 6-2

I

Idle mode 7-13, 8-2
In-Application Programming 4-10
Input class 13-8
Instruction decoder 2-2
Instruction timing 2-8, 2-10
 CPU state 2-8
 Mnemonic 2-10
 Wait state 2-8
In-System Programming 4-9
Internal analog clock 13-3
 Maximum frequency 13-3
Internal data memory 3-3
Internal RAM 3-1
Interrupt handling 5-23
Interrupt priority 5-21
Interrupt request flags 5-22
Interrupt response time 5-24
Interrupt source and vector 5-2, 5-8
Interrupt system 5-1
 Register description 5-9

J

JTAG ID 14-9

K

Kernel registers 6-5
 Direction control register 6-7
 Offset addresses 6-5

L

Limit checking 13-17
 LIN 10-14–10-18
 Baud rate detection 10-17
 Break field 10-15
 Header transmission 10-16
 LIN frame 10-14
 LIN protocol 10-14
 Synch byte 10-15

M

Maskable interrupt 5-1
 Extended 5-2
 External 5-2
 Internal 5-1
 Memory organization 3-1
 Special Function Registers 3-4
 Address extension by mapping 3-4
 Mapped 3-4
 Standard 3-4
 Address extension by paging 3-6
 Local address extension 3-6
 Save and restore 3-7
 Minimum erase width 4-3
 Modulation 12-13
 Monitor mode control 14-2
 Monitor RAM 14-2
 Data 14-6
 Stack 14-6
 Monitor ROM 14-2
 Multi-channel mode 12-17
 Multifold replications 4-4
 Multiprocessor communication 10-7

N

Non-maskable interrupt 5-1
 Events 5-1

O

On-Chip Debug Support 14-1
 Register description 14-7
 Register map 14-7
 On-chip oscillator 7-9

P

P0 register description 6-5, 6-16
 P1 register description 6-21
 P2 register description 6-26
 P3 register description 6-31
 Parallel ports 6-1
 Bidirectional port structure 6-3
 Driver 6-2, 6-7
 General port structure 6-3
 General register description 6-5
 Input port structure 6-4
 Kernel registers
 Open drain control register 6-7
 Normal mode 6-2, 6-7
 Open drain mode 6-2, 6-7
 Parallel request source 13-13
 Permanent arbitration 13-9
 Personal computer host 4-9
 P-Flash 4-2, 4-3
 Phase-Locked Loop 7-9
 Changing PLL parameters 7-11
 Loss-of-Lock operation 7-10
 Loss-of-Lock recovery 7-10
 Pin
 Configuration 1-5
 Definitions and functions 1-6
 PLL
 Loss-of-lock 7-10
 Startup 7-10
 PLL base mode 7-12
 PLL bypass 7-11
 PLL mode 7-12
 Power control 2-7
 Power saving modes 8-1
 Power supply system 7-1
 Power-down mode 7-13, 8-3

- Entering power-down mode 8-3
- Exiting power-down mode 8-3
- Power-down wake-up reset 7-4
- Power-on reset 7-2, 7-3
- Prescaler mode 7-12
- Prewarning period 9-2
- Processor architecture 2-1
 - Instruction timing
 - Machine cycle 2-8
 - Register description 2-4
- Program counter 2-3
- Program Flash 4-2, 4-3
- Program memory 3-3
- Program status word 2-5
- Pull-down device 6-8
- Pull-up device 6-8
- Pulse width modulation 12-1

R

- Read access time 4-1
- Receive-buffered 10-2
- Request gating 13-12
- Request trigger 13-12, 13-14, 13-25
 - CCU6 Event 13-25
- Reset control 7-3
 - Module behavior 7-6
- Result FIFO 13-19
- Result read view 13-19
 - Accumulated 13-19
 - Normal 13-19
- ROM devices 3-1, 3-2
- ROM program memory 3-1
- RS-232 4-9

S

- Sample phase 13-5
- Schmitt-Trigger 6-2, 6-4
- Sectorization 4-3
- Sequential request source 13-11
- Serial data 6-2
- Serial interfaces 10-1–10-18
- Serial port 6-2
- Slow-down mode 7-13, 8-2

- Software breakpoints 14-5
 - Break before make 14-5
- Source priority 13-9
- Special Function Register area 3-1
- Stack pointer 2-4
- Synchronization phase 13-5
- Synchronous serial interface 10-19
 - Data width 10-20
 - Error detection 10-27
 - Baud rate error 10-28
 - Phase error 10-28
 - Receive error 10-28
 - Transmit error 10-29
- Interrupts 10-27
- Master mode 10-19
- Operating mode 10-20
- Right-aligned 10-20
- Slave mode 10-19

T

- Timer 0 and Timer 1 11-1–11-12
 - External control 11-2
 - Mode 0, 13-bit timer 11-3
 - Mode 1, 16-bit timer 11-4
 - Mode 2, 8-bit automatic reload timer 11-5
 - Mode 3, two 8-bit timers 11-6
 - Timer operations 11-1
 - Timer overflow 11-1
- Timer 2 11-13–11-21
 - Auto-Reload mode 11-16
 - Capture mode 11-16
 - Up/Down Count Disabled 11-13
 - Up/Down Count Enabled 11-14
- Timer T12 12-3
 - Capture mode 12-9
 - Center-aligned mode 12-4
 - Compare mode 12-6
 - Dead-time 12-8
 - Duty cycle 12-7
 - Edge-aligned mode 12-4
 - Hysteresis-like control mode 12-10
 - Shadow transfer 12-3

Single-shot mode 12-9
Three-phase PWM 12-1
Timer T13 12-11
 Compare mode 12-12
 Shadow transfer 12-11
 Single-shot mode 12-12
Total conversion time 13-6
Trap handling 12-16
Tristate 6-8

U

UART 10-2–10-13
 Interrupt requests 10-5
 Mode 1, 8-bit UART 10-2
 Mode 2, 9-bit UART 10-5
 Mode 3, 9-bit UART 10-5

V

VCO bypass 7-12

W

Wait-for-read mode 13-15
Wait-for-Start 13-10
Watchdog timer 9-1–9-8
 Input frequency 9-3
 Servicing 9-2
 Time period 9-3
Watchdog timer reset 7-4
Window boundary 9-2
Wordline address 4-5
Write buffers 4-6
Write result phase 13-5

X

XC866 register overview 3-13
XRAM 3-1

15.2 Register Index

This section lists the references to the Special Function Registers of the XC866.

A

A 2-4
ADC_PAGE 13-28

B

B 2-4
BCON 10-12
BG 10-13
BRH 10-37
BRL 10-37

C

CC63RH 12-43
CC63RL 12-43
CC63SRH 12-44
CC63SRL 12-44
CC6xRH (x = 0 - 2) 12-37
CC6xRL (x = 0 - 2) 12-37
CC6xSRH (x = 0 - 2) 12-38
CC6xSRL (x = 0 - 2) 12-38
CCU6_PAGE 12-26
CHCTR_x (x = 0 - 7) 13-36
CHINCR 13-52
CHINFR 13-52
CHINPR 13-53
CHINSR 13-53
CMCON 7-17
CMPMODIFH 12-47
CMPMODIFL 12-47
CMPSTATH 12-46
CMPSTATL 12-45
CONH 10-34, 10-35
CONL 10-33, 10-35
CRCR1 13-44
CRMR1 13-46
CRPR1 13-45

D

DPH 2-4
DPL 2-4

E

EO 2-6
ETRCR 13-35
EVINCR 13-54
EVINFR 13-54
EVINPR 13-55
EVINSR 13-55
EXICON0 5-12
EXICON1 5-13

F

FEAH 4-8
FEAL 4-8

G

GLOBCTR 8-9, 13-31
GLOBSTR 13-32

H

HWBPDR 14-8
HWBPSR 14-8

I

ID 3-15
IEN0 5-9, 11-12
IEN1 5-10
IENH 12-85
IENL 12-84
INPCR0 13-37
INPH 12-89
INPL 12-88
IP 5-19
IP1 5-20

IPH 5-19
 IPH1 5-20
 IRCON0 5-14
 IRCON1 5-15
 ISH 12-78
 ISL 12-77
 ISRH 12-83
 ISRL 12-82
 ISSH 12-81
 ISSL 12-80

L

LCBR 13-56

M

MCMCTR 12-70
 MCMOUTH 12-69
 MCMOUTL 12-67
 MCMOUTSH 12-66
 MCMOUTSL 12-65
 MMBPCR 14-7
 MMCR 14-7
 MMCR2 14-7
 MMDR 14-7
 MMICR 14-7
 MMSR 14-7
 MODCTRH 12-58
 MODCTRL 12-57
 MODPISEL 8-8, 10-13

N

NMICON 5-11
 NMISR 5-17

O

OSC_CON 7-14, 8-10

P

P0_ALTSEL0 6-18
 P0_ALTSEL1 6-18
 P0_DATA 6-16
 P0_DIR 6-16
 P0_OD 6-17

P0_PUDEN 6-18
 P0_PUDSEL 6-17
 P1_ALTSEL0 6-23
 P1_ALTSEL1 6-23
 P1_DATA 6-21
 P1_DIR 6-21
 P1_OD 6-22
 P1_PUDEN 6-23
 P1_PUDSEL 6-22
 P2_DATA 6-26
 P2_PUDEN 6-27
 P2_PUDSEL 6-26
 P3_ALTSEL0 6-33
 P3_ALTSEL1 6-33
 P3_DATA 6-31
 P3_DIR 6-31
 P3_OD 6-32
 P3_PUDEN 6-33
 P3_PUDSEL 6-32
 PASSWD 3-12
 PCON 2-7, 8-7, 10-10
 PISEL 10-32
 PISEL0H 12-33
 PISEL0L 12-31
 PISEL2 12-34
 PLL_CON 7-15
 PMCON0 7-7, 8-6, 9-8
 PMCON1 8-8, 13-7
 PORT_PAGE 6-11
 PRAR 13-33
 PSLR 12-63
 PSW 2-5
 Px_ALTSELn 6-10
 Px_DATA 6-6
 Px_DIR 6-7
 Px_OD 6-7
 Px_PUDEN 6-8
 Px_PUDSEL 6-8

Q

Q0R0 13-40
 QBUR0 13-42
 QINR0 13-43

QMR0 13-38

QSR0 13-40

R

RBL 10-38

RC2H 11-20

RC2L 11-20

RCRx (x = 0 - 3) 13-50

RESRAxH (x = 0 - 3) 13-49

RESRAxL (x = 0 - 3) 13-49

RESRxH (x = 0 - 3) 13-49

RESRxL (x = 0 - 3) 13-49

S

SBUF 10-7

SCON 5-17, 10-8

SCU_PAGE 3-10

SP 2-4

SYSCON0 3-4

T

T12DTCH 12-39

T12DTCL 12-39

T12H 12-35

T12L 12-35

T12MSELH 12-73

T12MSELL 12-72

T12PRH 12-36

T12PRL 12-36

T13H 12-41

T13L 12-41

T13PRH 12-42

T13PRL 12-42

T2CON 11-19

T2H 11-21

T2L 11-21

T2MOD 11-17

TBL 10-38

TCON 5-16, 11-10

TCTR0H 12-49

TCTR0L 12-48

TCTR2H 12-54

TCTR2L 12-52

TCTR4H 12-56

TCTR4L 12-55

THx (x = 0 - 1) 11-8

TLx (x = 0 - 1) 11-8

TMOD 11-11

TRPCTRH 12-61

TRPCTRL 12-60

V

VFCR 13-50

W

WDTCON 9-6

WDTH 9-7

WDTL 9-7

WDTREL 9-5

WDTWINB 9-7

<http://www.infineon.com>

Published by Infineon Technologies AG