

e2v

e2v technologies

The data to be read in conjunction with the Hydrogen Thyatron Preamble.

ABRIDGED DATA

Hydrogen-filled tetrode thyatron with ceramic envelope, featuring extremely low jitter, low anode delay time drift and high rate of rise of current. A hydrogen reservoir operating from a separate, variable heater supply is incorporated.

CX1599 is a fast, precise switch originally designed for use in pulse generators to drive Kerr cells, Pockel cells or spark chambers. Anode voltage must be command charged and applied for less than 10 ms. The tube geometry allows it to be mounted in a coaxial housing in order to minimise the total circuit inductance.

Peak forward anode voltage (see note 1)	12.5	kV max
Peak anode current	1000	A max
Anode heating factor	12.5×10^7	VApps max
Peak output power	6.25	MW max
Rate of rise of anode current		
(see notes 2 and 3)	100	kA/ μ s
Typical jitter (see note 3)	0.2	ns
Typical p.r.f.	10	Hz

GENERAL

Electrical

Cathode (connected internally to one end of heater)	oxide coated
Cathode heater voltage (see note 3)	$6.8 \begin{matrix} + 0.0 \\ - 0.3 \end{matrix}$ Vdc
Cathode heater current	9.5 A
Reservoir heater voltage (see note 4)	4.0 V nom
Reservoir heater current	1.5 A
Tube heating time (minimum)	5.0 minutes

Mechanical

Seated height	79.38 mm (3.125 inches) max
Clearance required below mounting flange	31.75 mm (1.250 inches) min
Overall diameter (mounting flange)	57.15 mm (2.250 inches) nom
Net weight	284 g (10 ounces) approx
Mounting position (see note 5)	any
Tube connections	see outline

Cooling

Where natural cooling is insufficient to maintain the envelope temperatures below the specified rated values, cooling by forced-air, or by oil or coolant immersion may be used.

The temperature of the anode terminal and the base, measured at the points indicated on the outline drawing, must not exceed the values specified below.

Anode terminal	250	°C max
Base	220	°C max

CX1599 Hydrogen-Filled Ceramic Thyatron



FAST RISE TIME PULSE GENERATOR SERVICE
MAXIMUM AND MINIMUM RATINGS (Absolute values)

	Min	Typical	Max	
Anode				
Peak forward anode voltage (see note 1)	-	-	12.5	kV
Peak inverse anode voltage (see note 6)	-	-	12	kV
Peak anode current	-	-	1000	A
Pulse duration	-	-	0.5	μs
Rate of rise of anode current (see notes 2 and 7)	-	-	100	kA/μs
Anode heating factor	-	-	12.5 x 10 ⁷	VApps

Grid 2				
Unloaded grid 2 drive pulse voltage (see note 8)	250	500	750	V
Grid 2 pulse duration	0.1	-	5.0	μs
Rise time of grid 2 pulse (see note 2)	-	5.0	-	ns
Grid 2 pulse delay	0.25	0.3	-	μs
Loaded grid 2 bias voltage (see note 9)	-25	-	-200	V
Forward impedance of grid 2 drive circuit	50	-	1000	Ω

Grid 1 - Pulsed				
Unloaded grid 1 drive pulse voltage (see note 8)	300	500	750	V
Grid 1 pulse duration	0.3	-	-	μs
Rate of rise of grid 1 pulse (see note 2)	1.0	-	-	kV/μs
Loaded grid 1 bias voltage	-	-	-	see note 10
Peak grid 1 drive current (see note 9)	2.0	-	50	A

Cathode				
Heater voltage (see note 3)	-	6.8	-	V dc
Heating time	5.0	-	-	min

Reservoir				
Reservoir voltage (see note 4)	4.0	-	7.5	V
Heating time	5.0	-	-	min

Environmental				
Ambient temperature	-20	-	+ 130	°C
Altitude	-	-	3	km
	-	-	10 000	feet

CHARACTERISTICS

	Min	Typical	Max	
Critical DC anode voltage for conduction	-	0.2	0.3	kV
Anode delay time (see note 11)	-	0.03	-	μs
Anode delay time drift (see note 12)	-	5.0	-	ns
Time jitter (see note 3)	-	0.2	1.0	ns
Recovery time	-	-	-	see graph, page 4
Heater current (at 6.8 V)	9.5	10	10.5	A
Reservoir current (at 6.8 V)	1.0	1.5	2.0	A

NOTES

1. Anode voltage must be command charged and applied for < 10 ms. The tube will not operate with DC anode voltage.
2. This rate of rise refers to that part of the leading edge of the pulse between 10% and 90% of the pulse amplitude.
3. The jitter levels and rate of rise of current specified in this data sheet for fast rise time generator service can only be obtained under very carefully controlled conditions. e2v technologies therefore reserves the right to approve all equipments in which the tube is used. DC heater power supplies are needed to achieve the best jitter figures. If jitter is not critical then an AC transformer can be used.
4. **A recommended reservoir voltage is stamped on each tube. For the fastest switching speed, the reservoir voltage should be increased to a maximum value consistent with anode voltage hold-off in the equipment.**

The reservoir heater supply must be obtained either from the cathode heater supply or if a separate supply is used it must be decoupled to avoid damage to the reservoir.
5. The tube must be mounted by means of its mounting flange.
6. The peak inverse voltage including spike must not exceed 1.0 kV for the first 25 μ s after the anode pulse.
7. For single-shot or low p.r.f. applications this parameter can exceed 100 kA/ μ s. The ultimate value which can be attained depends also to a large extent upon the external circuit.
8. Measured with respect to cathode. When grid 1 is pulse driven, at least the first 0.25 μ s of the top of the grid 1 pulse must precede the delayed grid 2 pulse.
9. The tube may be operated with a loaded grid 2 bias voltage of 0 to -25 V provided that care is taken to ensure that the peak grid 1 drive current is sufficiently low to prevent triode firing (tube control by the grid 1 pulse).
10. DC negative bias voltages must not be applied to grid 1. When grid 1 is pulse driven, the potential of grid 1 may vary between -10 and +5 V with respect to cathode potential during the period between the completion of recovery and the commencement of the succeeding grid pulse.
11. The time interval between the instant when the unloaded grid 2 voltage passes cathode potential and the instant when anode conduction takes place.
12. The drift in delay time over a period from 10 seconds to 10 minutes of high voltage operation.

HEALTH AND SAFETY HAZARDS

e2v technologies hydrogen thyratrons are safe to handle and operate, provided that the relevant precautions stated herein are observed. e2v technologies does not accept responsibility for damage or injury resulting from the use of electronic devices it produces. Equipment manufacturers and users must ensure that adequate precautions are taken. Appropriate warning labels and notices must be provided on equipments incorporating e2v technologies devices and in operating manuals.



High Voltage

Equipment must be designed so that personnel cannot come into contact with high voltage circuits. All high voltage circuits and terminals must be enclosed and fail-safe interlock switches must be fitted to disconnect the primary power supply and discharge all high voltage capacitors and other stored charges before allowing access. Interlock switches must not be bypassed to allow operation with access doors open.



X-Ray Radiation

All high voltage devices produce X-rays during operation and may require shielding. The X-ray radiation from hydrogen thyratrons is usually reduced to a safe level by enclosing the equipment or shielding the thyratron with at least 1.6 mm ($1/16$ inch) thick steel panels.

Users and equipment manufacturers must check the radiation level under their maximum operating conditions.

MAXIMUM RECOVERY CHARACTERISTICS

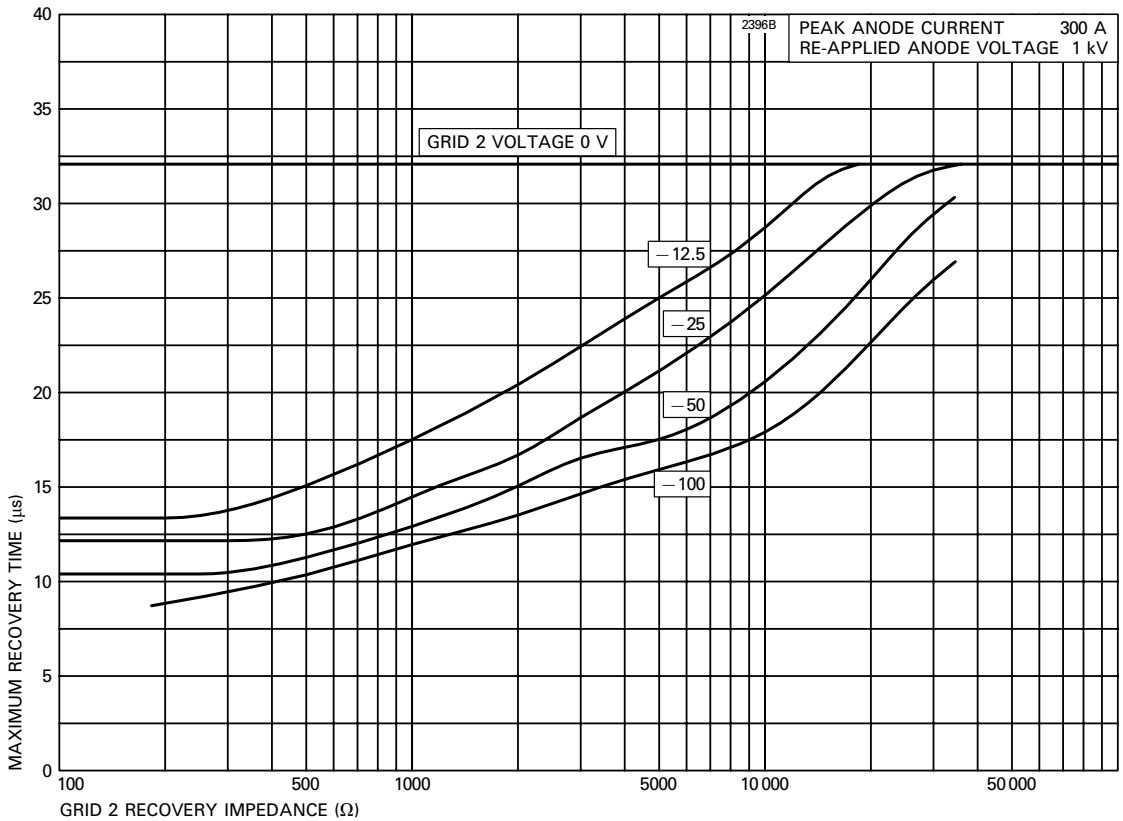

SCHEMATIC DIAGRAM

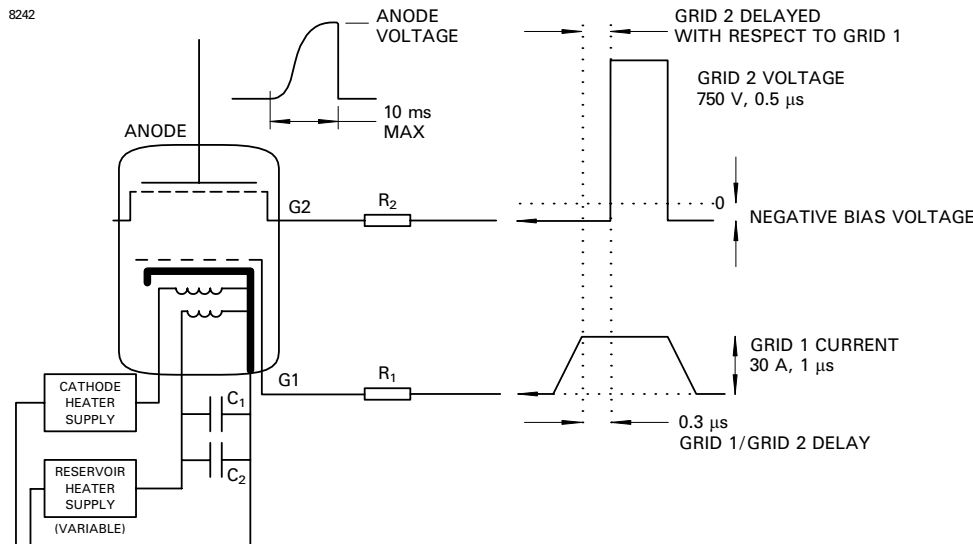

RECOMMENDED GRID, CATHODE AND RESERVOIR HEATER CONNECTIONS

R₁ = Grid 1 series resistor. 12 W vitreous enamelled wirewound is recommended, of a total impedance to set the grid 1 drive pulse circuit.

R₂ = Grid 2 series resistor. 12 W vitreous enamelled wirewound is recommended, of an impedance to match the grid 2 drive pulse circuit.

C₁, C₂ = reservoir protection capacitors with a voltage rating ≥ 500 V;

C₁ = 1000 pF low inductance (e.g. ceramic),

C₂ = 1 μF (e.g. polycarbonate or polypropylene).

Components R₁, R₂, C₁ and C₂ should be mounted as close to the tube as possible.

OUTLINE

(All dimensions without limits are nominal)

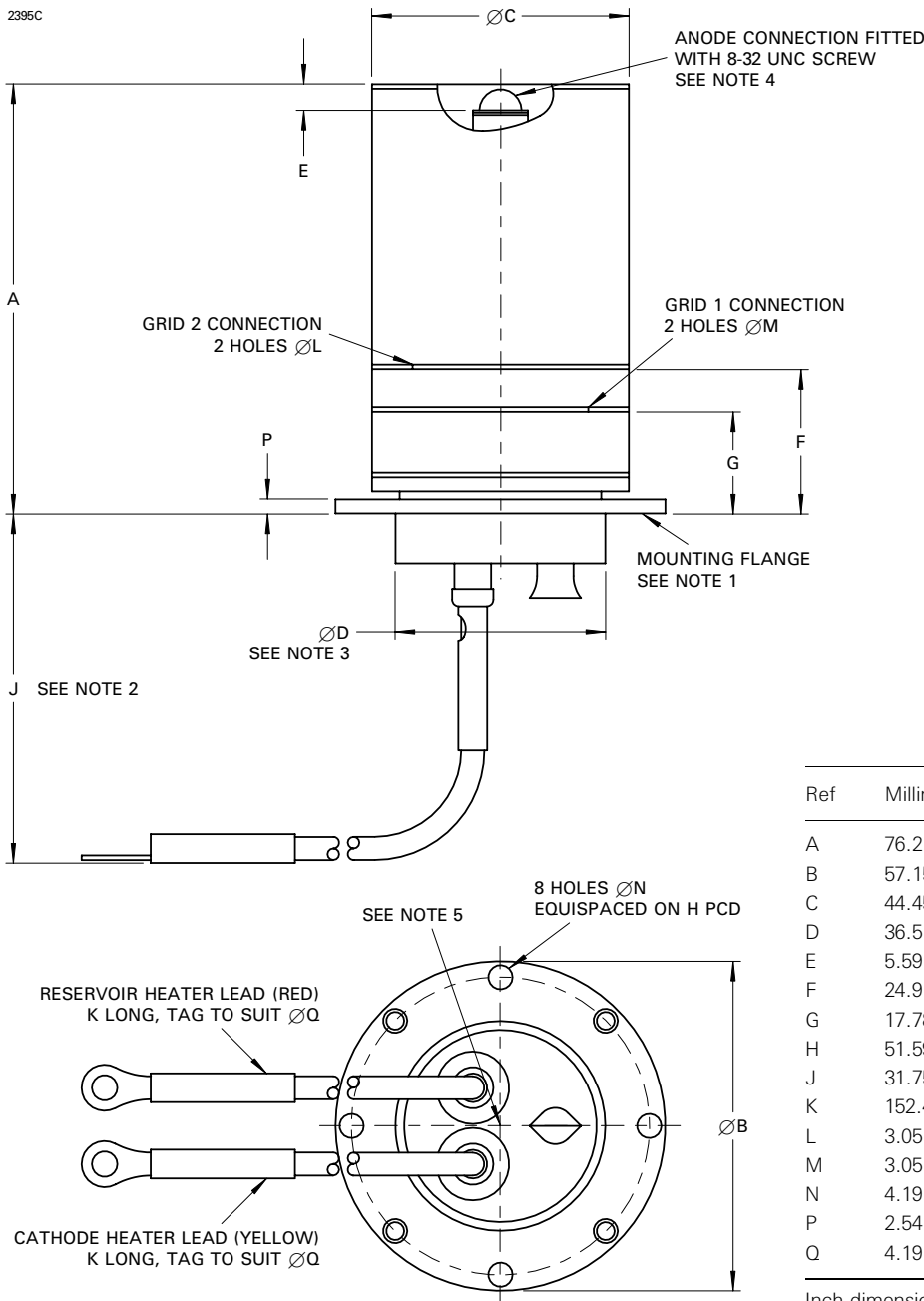

Ref	Millimetres	Inches
A	76.2 max	3.000 max
B	57.15	2.250
C	44.45 ± 0.79	1.750 ± 0.031
D	36.5	1.437
E	5.59 ± 0.38	0.220 ± 0.015
F	24.9	0.980
G	17.78	0.700
H	51.59 ± 0.25	2.031 ± 0.010
J	31.75 min	1.250 min
K	152.4	6.000
L	3.05	0.120
M	3.05	0.120
N	4.19	0.165
P	2.54	0.100
Q	4.19	0.165

Inch dimensions have been derived from millimetres.

Outline Notes

1. The mounting flange is the connection for the cathode, cathode heater return and reservoir heater return.
2. A minimum clearance of 31.75 mm (1.250 inches) must be allowed below the flange.
3. The recommended mounting hole is 38.1 mm (1.500 inches) diameter.
4. The anode temperature is measured at the base of the anode stem.
5. The base temperature is measured at this point.

Whilst e2v technologies has taken care to ensure the accuracy of the information contained herein it accepts no responsibility for the consequences of any use thereof and also reserves the right to change the specification of goods without notice. e2v technologies accepts no liability beyond that set out in its standard conditions of sale in respect of infringement of third party patents arising from the use of tubes or other devices in accordance with information contained herein.