

96-CHANNEL DISCRETE-TO-DIGITAL INTERFACE

DESCRIPTION	APPLICATIONS
<p>The DD-03296 device is a 96-channel discrete-to-digital interface with universal HIRF-isolated inputs that accept 28 V/Open, Open/Gnd and 28 V/Gnd signals.</p> <p>The output is an addressable 8- or 16-bit tri-state port, selectable for channel data, status, bounce, built-in self-test (BIST) and major fault, and is compatible with TTL logic.</p>	<p>The DD-03296 is specifically designed to address built-in self-test autonomy, fault isolation and tolerance.</p> <p>Because of its high reliability and low cost, these features enable the DD-03296 to satisfy a variety of interface requirements in aerospace applications, including flight critical, essential, and nonessential functions.</p>

FEATURES

- **HIRF Layer**
- **Universal Inputs**
28 V/Gnd
Open/Gnd
28 V/Open
- **Built-in Self-Test**
- **Soft Failure Reporting**
Higher MTBUR
- **ARINC 429 Output Port**

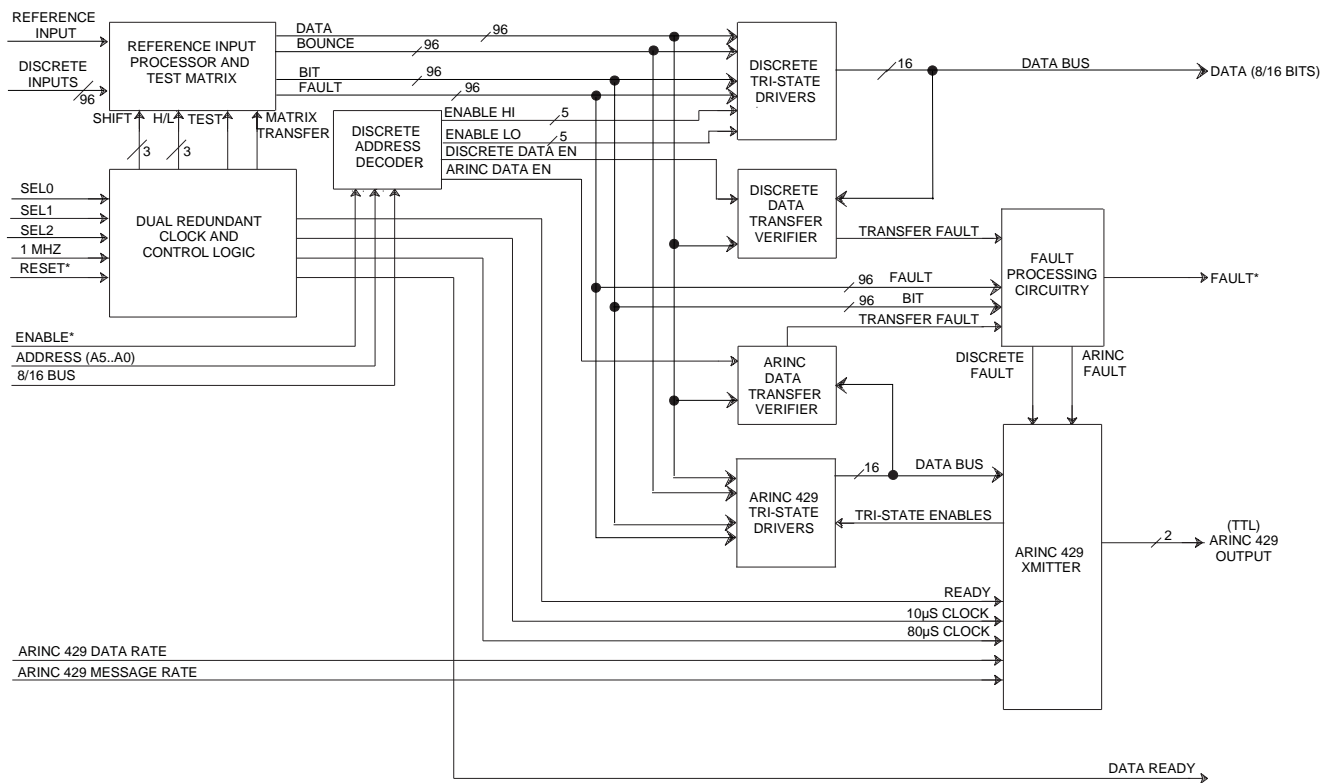

NOTE: (*) Indicates active low.

FIGURE 1. DD-03296 BLOCK DIAGRAM

TABLE 1. DD-03296 SPECIFICATIONS				
PARAMETER	UNITS	MIN	TYP	MAX
ABSOLUTE MAXIMUM RATINGS				
Supply Voltages (V_{CC} , V_{DD})	V	-0.3	5.0	7.0
Reference Inputs	V	-80		80
Discrete Inputs	V	-80		80
Digital Inputs	V	-0.3		$V_{DD}+0.3$
OPERATING CONDITIONS				
Supply Voltages (V_{DD})	V	4.5		5.5
DIGITAL				
INPUTS/OUTPUTS				
Logic Compatibility	TTL/ CMOS			
Digital Inputs				
■ V_{IH}	V	2.0		
■ V_{IL}	V			0.8
■ V_{IL} ($V_{IN} = 0$)	μA	-40		-400
Clock Input (See Note 1)	MHZ	0.99	1.00	1.01
Digital Outputs				
■ V_{OH} ($I_{OH} = -1ma$)	V	$V_{DD}-0.5$		
■ V_{OH} ($I_{OH} = -4ma$)	V	2.4		
■ V_{OL} ($I_{OH} = 4ma$)	V			0.4
ANALOG INPUTS		See FIGURE 4		
POWER SUPPLY REQUIREMENTS				
(Total V_{DD} , Analog & Digital)				
I_{DD} ($V_{DD} = +5V$ [Digital Outputs Unloaded])	mA		25	45
POWER DISSIPATION				
P_D	mw		125.0	250.0
THERMAL				
Operating Temperature				
■ Type 2	$^{\circ}C$	-40		85
Storage Temp	$^{\circ}C$	-65		150
Lead Temperature				
(Localized, 1 sec. duration)	$^{\circ}C$			280
(Body, 2 sec. duration)	$^{\circ}C$			210
Junction Temperature				
θ_{jc}	$^{\circ}C/W$		5.0	
θ_{ca}	$^{\circ}C/W$		20.0	
MTBF per Mil-Hbk-217 for Airborne Inhabited Cargo at 64 $^{\circ}C$		1,400,000 hrs. plastic		
PHYSICAL CHARACTERISTICS				
Size	in (cm)	2.3 x 2.3 (5.84 x 5.84)		
Weight	oz (gm)	0.83 23.5		

Note 1: ARINC 429 bit rate is derived from the clock. Refer to ARINC 429 Bit Rate to avoid interference. ARINC 429-14 (January 4, 1993), paragraph 2.4 "Timing Related Elements" contains a "COMMENTARY" section following subparagraph 2.1.4.2 ("Low-Speed Operation") that cautions against using "precisely" 100 kilobits per second.

WHAT IS A DISCRETE?

Advisory Circular (FAA), Airworthiness Approval of Traffic Alert and Collision Avoidance Systems (TCAS II) and Mode S Transponders, AC20-131, defines a discrete as "a separate, complete and distinct signal." In many instances these signals are binary, on or off, 28 V-based signals; they are typically Open/Gnd, 28 V/Open, or 28 V/Gnd with very low bandwidth (DC to 200 Hz).

Although the translation of these signals to TTL-levels that are compatible with digital avionics may seem simple, RTCA DO-160 power, lightning and high-intensity-radiated-fields (HIRF) are complicating factors. Add to that the desire to have a standardized, addressable, reliable interface and the challenge becomes apparent.

Today's systems address the interface requirements with circuits tailored for each interface comprised of R-C input filters, divider networks, diode isolation and comparators. Multichannel interfacing to a processor requires additional logic and latches. The resulting circuit generally lacks any built-in test capability, consumes considerable pc-board real estate (up to one sq. in. per channel) and offers no chip-level redundancy.

FUNCTIONAL INTEGRATION

Using the aggregated signal definition and functional requirements of industry, ILC Data Device Corporation has developed a discrete interface with universal HIRF-isolated inputs to handle 28V/Open, Open/Gnd and 28V/Gnd signals. Each channel is routed through a HIRF filter and comparator. Its output is a selectable 8- or 16-bit tri-state port, addressable for channel data, status, bounce, built-in self-test and major fault information.

This design specifically addresses built-in self-test autonomy, fault isolation and tolerance; moreover, its functional integration results in significant added reliability. A comparative look at MTBF, calculated in accordance with MIL-HBK-217 for airborne inhabited cargo environments at 64 $^{\circ}C$, indicates an order of magnitude improvement (1,400,000 hours vs. 173,000 hours) for a plastic packaged integrated approach vs. a similarly packaged discrete-component implementation. In addition, the real estate used is reduced from as much as 64 to 5 square inches.

Additional key DD-03296 features include:

BOUNCE: Relays and switches, as mechanical devices, have a characteristic 'bounce' to their signal transition. It is desirable to mask this bounce by delaying the output digital transition accordingly. This sampling rate of the device can be varied to allow for debounce of relay/switch inputs. In addition, the triple-sampling of a given comparator enables a consistent reading of otherwise asynchronous signals. Bounce is an addressable sta-

tus that allows the user to detect bouncing or intermittent relays/switches.

GROUND DIFFERENTIALS: When the reference inputs are connected to the 28V supply, the thresholds are designed to tolerate $\pm 3.5V$ ground differences.

REGISTERS: 8- or 16-bit selectable data or status are available via tri-state buffers for interfacing to any system processor.

ARINC 429 PORT: A serial ARINC 429 output is available for data-concentrator applications. This enables the transfer of data to other systems with a minimum of wiring and processor loading.

HIRF: The device incorporates passive circuitry to isolate the intelligence from both lightning effects and radiated fields as defined in DO-160. This protection is applicable to the discrete inputs, reference inputs and their relationship to each other and to ground.

TEST PATTERNS: Internal Test Patterns can be selected to produce alternating "1"s and "0"s to verify that all address and data bits are operational. While these outputs are always available, **regardless** of READY state, they must be addressed by the user (A5... A0) in accordance with TABLES 3 and 4.

DISSIMILAR PATHS: Errors are reported through registers and the ARINC 429 port as cross-checks.

INTELLIGENCE: The device's built-in self-test, status reporting scheme and isolation significantly reduces application software requirements. FIGURE 1 illustrates the model DD-03296 functional block diagram.

ASYNCHRONOUS SAMPLING: The device takes three samples on each encode because input discrete transition is asynchronous and reports the "majority" state.

MICROPROCESSOR INTERFACE

READ CYCLE TIMING

The DD-03296 is configured with either an 8- or 16-bit microprocessor. FIGURE 2 illustrates this interface.

The read cycle(s) should be preceded by polling the device's READY bit located within the Status Register. The Status Register can be read at any time regardless of the state of the READY signal (pin 16) from the device.

If the READY bit is a logic "1" (this can be easily tested by a branch if negative statement), the address of the desired register, along with the negative true $\overline{\text{ENABLE}}$ signal, should be pre-

sented to the device. The addressed data will be available within 100 nsec.

After the data is read, the $\overline{\text{ENABLE}}$ line should be returned to a logic "1" level before the address is changed.

All of the data within the device is guaranteed to remain stable for at least 20 μsec after the high-to-low transition of the READY signal (See FIGURE 3).

ANALOG INPUTS

ANALOG INPUT CHANNELS: (Pins 161, 162, 1-6, 8-15, 19-26, 29-36, 45-52, 55-62, 66-73, 76-83, 85-92, 95-102, 105-112, 115-122) 600k Ω input resistance, 500 μs time constant, responsive to Open/Gnd (when configured with appropriate external pull-up), 28V/Open and 28/Gnd input with HIRF/lightning immunity. Refer to FIGURE 4 for detail of the input structure.

REFERENCE: Configured for 28V tracking discretes. User adjustable for other reference levels by connecting external resistors between corresponding TRIM and REF inputs.

FIGURE 4 also shows the reference structure. Each set of Ref/Trim inputs are configured by the user for a bank of 32-channel inputs. (See FIGURE 4 and TABLE 8)

REF A, B, C: (Pins 37, 65, and 75) Input to the divider supplying the reference voltage to the "A," "B" and "C" group of 96 input channels.

TRIM A, B, C: (Pins 38, 64, and 74) Junction of the first resistor and the rest of the reference "A," "B" and "C" divider.

DIGITAL INPUTS

DEBOUNCE (SEL2...SEL0): (Pins 158-160) The Input Discrete Sampling Rate (Debounce Time) is user-programmable via the three Select lines (SEL2...SEL0) in accordance with TABLE 2. The intent of this function is to mask the bounce of the input dis-

SELECT (SEL2...SEL 0)	SAMPLE RATE
000	5 msec
001	10 msec
010	20 msec
011	50 msec
100	100 msec
101	200 msec
110	500 msec
111	1000 msec

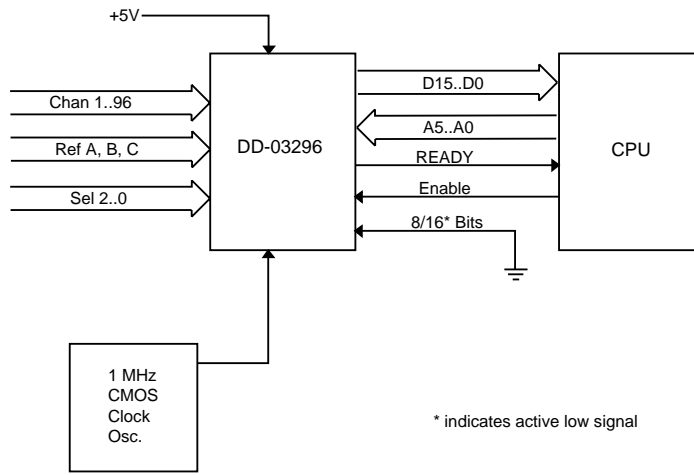

NOTE: 1) If 8/16* Bits pin is tied to +5V, then the DD-03296 is configured for 8-Bit Mode.

The following must also be modified:
 D0 tied to D8
 D1 tied to D9
 D2 tied to D10
 D3 tied to D11
 D4 tied to D12
 D5 tied to D13
 D6 tied to D14
 D7 tied to D15

2) If the ARINC 429 option is not used, then pin 153 (429STRBI) MUST be grounded for the "bounce" circuit to operate properly.

FIGURE 2. DD-03296-TO-CPU INTERFACE

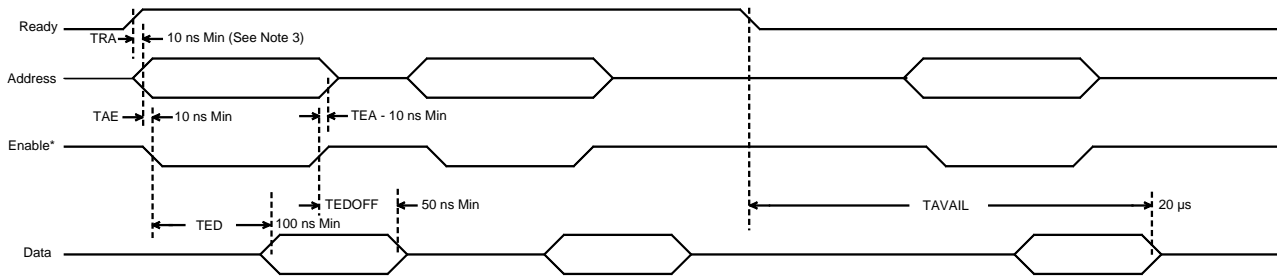

Note:
 1) TRA = Time Ready Address
 2) TAE = Time Address Enable
 3) TEA = Time Enable to Address
 4) TED = Time Enable Data
 5) TEDOFF = Time Enable Off - Data Off
 6) TAVAIL = Time Ready - Data Available
 7) (*) Indicates active low.
 8) The ready "on-time" = (sample rate - 440 μs)
 Sample rate is programmable via SEL0 - SEL2 (See TABLE 2)

FIGURE 3. READ CYCLE TIMING

crete appropriate to its characteristic performance. See **BOUNCE** on page 2.

ENABLE: (Pin 147) The $\overline{\text{ENABLE}}$ line controls the tri-state drivers of the 8- or 16-bit Data Bus outputs. The tri-state Data Bus drivers are enabled when this signal is a logic "0," and are tri-stated when this signal is a logic "1." $\overline{\text{ENABLE}}$ is a read signal and should only be low during read cycles.

8/16 BITS: (Pin 104) A logic "0" selects the 16-bit data bus output and a logic "1" selects the 8-bit data bus output.

ADDRESS LINES (A5...A0): (Pins 139, 140 and 143-146) The six address lines (A5...A0, where A0 is the LSB) provide for the selection of the desired 8- or 16-bit Data Bus information in accordance with TABLE 3 and TABLE 4 (Word/Byte Modes).

CLOCK (1MHZ CLK): (Pin 28) The user must supply a 1 MHz clock whose stability is of no importance except to the serial bit rate of the ARINC 429 port (see Note 1 of TABLE 1). The clock is brought into the internal ASIC at two widely separated points designated as CLOCK_A (primary) and CLOCK_B (secondary) path.

The primary clock path will be selected and drive the device unless a primary clock path fault is detected, in which case the operation of the device will get switched over to the secondary clock path.

Both clock paths are continually monitored for status and this information is available as separate bits in the Status Register.

FACTORY TEST INPUTS: (Pins 39, 40, 149 and 150) The $\overline{\text{TMUX}}$, $\overline{\text{TMODE}}$, $\overline{\text{FMUX}}$ and $\overline{\text{FMODE}}$ input signals are used for factory testing and should be tied to logic "1" for the device to operate properly.

RESET: (Pin 41) The $\overline{\text{RESET}}$ signal is used to reset the device during factory testing. It may be connected to an external RC network to provide a Power-on-Reset for the device. Under normal operating conditions this pin should be a no-connect. If there is some reason to reset the device from external circuitry this pin can be momentarily pulled to logic "0" through an open collector device. **Do not hard wire this pin to +5V or ground.**

OUTPUTS

DATA (D15...D0): (Pins 123-138) 8-bit byte or 16-bit byte word information is available on the Data Bus depending on the logic state of the Bus Select line as described above.

In the Byte mode the upper and lower bytes are enabled separately so that bit 0 can be hard-wired to bit 8, bit 1 to bit 9 etc., thereby providing an 8-bit data bus.

It is important that the 8-bit mode be selected if these data bits are wired together or corrupted data will result. The available data can be found under the Address Lines section found on page 5.

FAULT: (Pin 148) The $\overline{\text{FAULT}}$ flag was designed to serve as an interrupt to the microprocessor when a HARD error has been detected within the device (See Note 2 of TABLES 3 and 4). If this

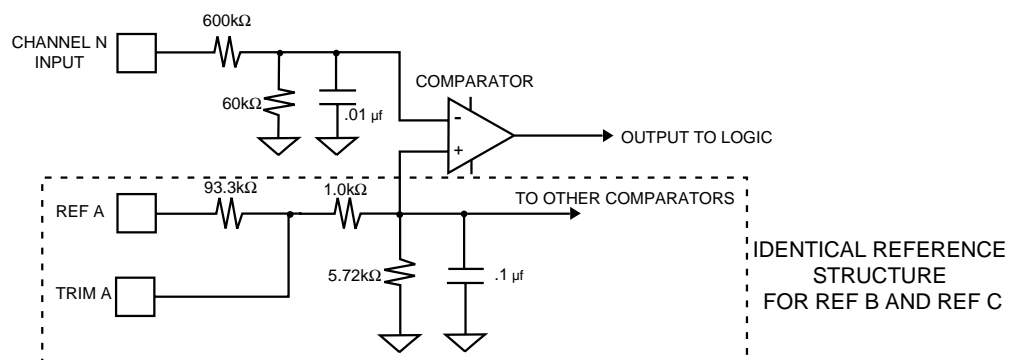

FIGURE 4. DD-03296 INPUT STRUCTURE

TABLE 3. WORD MODE (16-BIT BUS)	
ADDRESS (A5 .. A0)	DATA (D15..D0)
00 000X	BOUNCE CH_16 CH_01
00 001X	BOUNCE CH_32 CH_17
00 010X	BOUNCE CH_48 CH_33
00 011X	BOUNCE CH_64 CH_49
00 100X	BOUNCE CH_80 CH_65
00 101X	BOUNCE CH_96 CH_81
00 110X	FAULT CH_16..CH_01
00 111X	FAULT CH_32..CH_17
01 000X	FAULT CH_48..CH_33
01 001X	FAULT CH_64..CH_49
01 010X	TEST PATTERN 0's and 1's
01 011X	FAULT CH_80..CH_65
01 100X	FAULT CH_96..CH_81
01 101X	DATA CH_16..CH_01
01 110X	DATA CH_32..CH_17
01 111X	DATA CH_48..CH_33
10 000X	DATA CH_64..CH_49
10 001X	DATA CH_80..CH_65
10 010X	DATA CH_96..CH_81
10 011X	NOT USED
10 100X	STATUS REGISTER
10 101X	TEST PATTERN 1's and 0's
10 110X	FACTORY TEST WORD 1
10 111X	FACTORY TEST WORD 2
11 000X	FACTORY TEST WORD 3
11 001X	FACTORY TEST WORD 4
11 010X	NOT USED
11 011X	:
11 111X	NOT USED

TABLE 4. BYTE MODE (8-BIT BUS)	
ADDRESS (A5.. A0)	DATA (D7..D0)
00 0000	BOUNCE CH_08 CH_01
00 0001	BOUNCE CH_16 CH_09
00 0010	BOUNCE CH_24 CH_17
00 0011	BOUNCE CH_32 CH_25
00 0100	BOUNCE CH_40 CH_33
00 0101	BOUNCE CH_48 CH_41
00 0110	BOUNCE CH_56 CH_49
00 0111	BOUNCE CH_64 CH_57
00 1000	BOUNCE CH_73 CH_65
00 1001	BOUNCE CH_80 CH_74
00 1010	BOUNCE CH_88 CH_81
00 1011	BOUNCE CH_96 CH_89
00 1100	FAULT CH_08 CH_01
00 1101	FAULT CH_16 CH_09
00 1110	FAULT CH_24 CH_17
00 1111	FAULT CH_32 CH_25
01 0000	FAULT CH_40 CH_33
01 0001	FAULT CH_48 CH_41
01 0010	FAULT CH_56 CH_49
01 0011	FAULT CH_64 CH_57
01 0100	TEST PATTERN 0's and 1's
01 0101	TEST PATTERN 0's and 1's
01 0110	FAULT CH_73 CH_65
01 0111	FAULT CH_80 CH_74
01 1000	FAULT CH_88 CH_81
01 1001	FAULT CH_96 CH_89
01 1010	DATA CH_08..CH_01
01 1011	DATA CH_16..CH_09
01 1100	DATA CH_24..CH_17
01 1101	DATA CH_32..CH_25
01 1110	DATA CH_40..CH_33
01 1111	DATA CH_48..CH_41
10 0000	DATA CH_56..CH_49
10 0001	DATA CH_64..CH_57
10 0010	DATA CH_72..CH_65
10 0011	DATA CH_80..CH_73
10 0100	DATA CH_88..CH_81
10 0101	DATA CH_96..CH_89
10 0110	NOT USED
10 0111	NOT USED
10 1000	STATUS REGISTER LO
10 1001	STATUS REGISTER HI
10 1010	TEST PATTERN 1's and 0's
10 1011	TEST PATTERN 1's and 0's
10 1100	TEST WORD 1 LO
10 1101	TEST WORD 1 HI
10 1110	TEST WORD 2 LO
10 1111	TEST WORD 2 HI
11 0000	TEST WORD 3 LO
11 0001	TEST WORD 3 HI
11 0010	TEST WORD 4 LO
11 0011	TEST WORD 4 HI
11 0100	NOT USED
11 0111	:
11 1111	NOT USED

NOTES FOR TABLES 3 AND 4.	
Note 1:	A true BOUNCE bit indicates that the input signal of the associated channel changed in an alternating fashion, i.e., OFF-ON-OFF or ON-OFF-ON in three successive samples at the selected sampled rate.
Note 2:	A FAULT bit that is true indicates that the associated channel has a major problem and that the associated data should not be believed. A FAULT indication is a HARD FAULT condition indicating that the Built-In-Test has failed.
Note 3:	A DATA bit indicates the input discrete state for the associated channel over the last two data samples taken.
Note 4:	The two available TEST PATTERNS contain an alternating string of 1's and 0's, and 0's and 1's, which can be used to verify that all of the data bits are operational (i.e., there are no stuck bits). The two test patterns have been located at addresses of alternating address bits so that the address decoder bits are tested at the same time.

signal is asserted (logic "0") the Status Register should be read to determine the nature of the fault. Thereafter more detailed information can be found in the associated addressable registers. The Fault Flag will remain at a logic "0" for as long as the fault condition persists. FIGURE 5 illustrates the fault logic tree.

Note: Depending on the exact nature of the fault, the Fault Flag may return to logic "0" during the Built-In-Test interval (when the READY signal is at logic "0") if there is a persistent fault condition.

Fault Conditions:

FAULT is logic "0" for any of the following fault conditions. The reason for the fault can be obtained from the status register which is accessible **regardless** of READY state. TABLE 5 shows the contents of the status register.

A definition of each bit is as follows:

BIT FAULT: A logic "1" for this bit indicates that one of the channels has failed the Built-In-Test sequence; this bit sequence is performed prior to every input sample taken. These signals are reset at the start of each Built-In-Test sequence, and will be set if any of the tests in the sequence fail.

DISCRETE FAULT: A logic "1" for this bit indicates that one of the channels detected that the discrete input data word did not transfer to the data bus output properly when it was read. If a HARD fault was detected the offending channel can be determined by reading the associated FAULT data registers. If it was generated by a transfer error the DISCRETE TRANSFER FAULT bit in this status register will be set to logic "1."

ARINC FAULT: A logic "1" for this bit indicates that one of the channels detected a HARD failure during Built-In-Test sequence, or that the discrete input data word did not transfer to the ARINC transmitter section properly.

If a HARD fault was detected the offending channel can be determined by reading the associated FAULT data registers. If it was generated by a transfer error then no FAULT bits in the status register will be set to logic "1."

ARINC READY: A logic "0" for this bit indicates that an ARINC transmission is currently in progress. A logic "1" indicates that no ARINC transmission is in progress.

CLOCK_A FAULT: A logic "1" for this bit indicates that the primary 1 MHz clock circuitry is defective and that the device is running off the secondary 1 MHz clock.

CLOCK_B FAULT: A logic "1" for this bit indicates that the secondary 1 MHz clock currently is defective and cannot be used as a backup.

NO CLOCK: A logic "1" for this bit indicates that there is no 1 MHz clock being supplied to the device, or that both have failed.

DISCRETE TRANSFER FAULT: A logic "1" for this bit indicates that the discrete data word(s) did not transfer properly during the associated microprocessor read cycle (i.e., the word present on the data bus did not agree with internal data). The most likely cause of this type of fault condition is a collision on the data bus during the read cycle.

Note: This condition is only monitored for the discrete data words, not for all of the available data.

CLKTST: (Pin 157) This signal is used for factory testing and should not be connected to any external circuitry or normal operation of the device could be affected. Specifically, this signal is a low drive internal test point connected to the primary clock signal. Grounding this signal forces the device to switch to the secondary internal clock.

READY: (Pin 16) A logic "1" for this bit indicates that all of the available data is stable and can be read. A logic "0" indicates that the device is in Built-In-Test mode, or taking a sample of discrete input data lines.

The signal should be polled directly by reading the status word prior to performing any read cycles. The internal data is guaranteed to be stable for 20 µsec after the logic "1" to logic "0" transition (READY to NOT READY) of this signal. Therefore, it should not be necessary to repoll the signal after the read.

TABLE 5. STATUS WORD BIT MAP

BIT	SIGNAL
00 (LSB)	BIT FAULT
01	DISCRETE FAULT
02	ARINC FAULT
03	ARINC READY
04	CLOCK_A FAULT
05	CLOCK_B FAULT
06	NO CLOCK
07	DISCRETE TRANSFER FAULT
08	LOGIC LOW (HIGH BYTE)
09	LOGIC LOW
10	LOGIC LOW
11	LOGIC LOW
12	LOGIC LOW
13	LOGIC LOW
14	LOGIC LOW
15 (MSB)	READY

Note: All bits available regardless of ready-state.

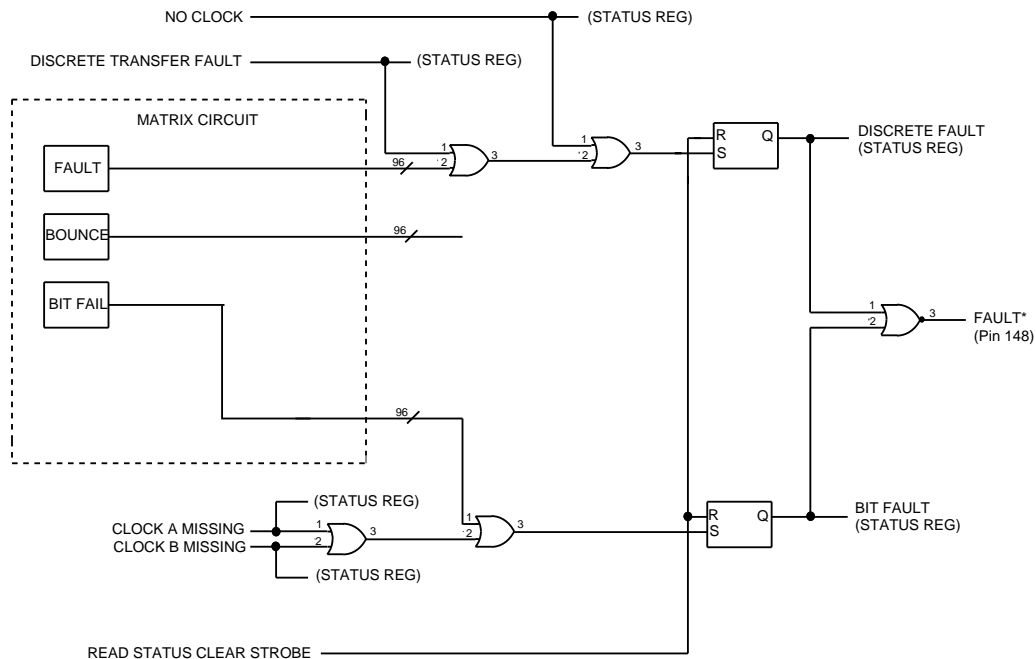

Note: (*) indicates active low.

FIGURE 5. FAULT LOGIC TREE

ARINC 429 PORT

This port enables the transmission of discrete data via a serial ARINC 429 (CMOS levels) output simultaneously with the 8/16-bit Bus output. The following features and pins apply:

ARINC 429 DATA RATE (429DRATE): (Pin 156) A logic "1" (or a no-connect) for this input selects the ARINC 429 Low-Speed data rate of 12.5 kHz. A logic "0" selects the High-Speed data rate of 100 kHz.

ARINC 429 MESSAGE RATE (429MRATE): (Pin 155) The message rate of the ARINC 429 output is selectable at either a fixed 100 ms rate or at the selected sampling rate of the input discrettes. A logic "1" selects the input sampling rate as the message rate, and a logic "0" selects the fixed 100 ms message rate.

Note: If the Low-Speed ARINC 429 bit rate is selected (12.5 kHz) an entire ARINC message will take about 52 ms to complete. Therefore, input discrete sampling rates of 5 msec, 10 msec, and 20 msec cannot be utilized or the ARINC message will be truncated unless the fixed 100 ms message rate is selected.

429 STROBE IN (429STRBI): (Pin 153) This pin is utilized in the special case where the device is being used as a remote ARINC

429 serial port and is not connected to a local microprocessor. When the device is being used in this specific configuration the associated 429 Strobe Out should be connected to this pin. In other cases this pin **must** be grounded.

Related Information: Because the BOUNCE data is momentarily latched within the device, this information is normally reset by a READ to the associated BOUNCE data words. In the instances when there is no microprocessor, and therefore no READS to the BOUNCE data, this connection provides a mechanism to reset the source of the BOUNCE information (just after it is transferred to the ARINC transmitter section) at the start of each ARINC message.

429 STROBE OUT (429STRBO): (Pin 154) This signal is used in conjunction with the "429 Strobe In" described above. It is a 500 ns positive pulse which occurs at the start of each 429 message. For further information concerning the use of this signal, see the 429 STROBE IN section.

ARINC_LO AND ARINC_HI: (Pin 151 and 152) These two signals comprise the ARINC 429 serial output transmission. Both are TTL-compatible signals where the ARINC_LO signal contains the logic "0" serial transmission and the ARINC_HI signal

TABLE 6. ARINC BIT DESCRIPTION

	P A R	SSM	M S B	16 BIT DATA																				L S B	F	C	SDI	LABEL REVERSED OCTAL								M S B	
				29	28	27	26	25	24	23	22	21	20	19	18	17	16	15	14	13	12	11	10					9	8	7	6	5	4	3	2		1
ARINC 429 BITS	32	31	30	29	28	27	26	25	24	23	22	21	20	19	18	17	16	15	14	13	12	11	10	9	8	7	6	5	4	3	2	1					
FAULT 16..1	P	A	B	D	D	D	D	D	D	D	D	D	D	D	D	D	D	D	D	D	E	F	C	G	H	1	0	0	0	0	0	0	0	001			
FAULT 32..17	P	A	B	D	D	D	D	D	D	D	D	D	D	D	D	D	D	D	D	D	E	F	C	G	H	0	1	0	0	0	0	0	0	002			
FAULT 48..33	P	A	B	D	D	D	D	D	D	D	D	D	D	D	D	D	D	D	D	D	E	F	C	G	H	1	1	0	0	0	0	0	0	003			
FAULT 64..49	P	A	B	D	D	D	D	D	D	D	D	D	D	D	D	D	D	D	D	D	E	F	C	G	H	0	0	1	0	0	0	0	0	004			
FAULT 80..65	P	A	B	D	D	D	D	D	D	D	D	D	D	D	D	D	D	D	D	D	E	F	C	G	H	1	0	1	0	0	0	0	0	005			
FAULT 96..81	P	A	B	D	D	D	D	D	D	D	D	D	D	D	D	D	D	D	D	D	E	F	C	G	H	0	1	1	0	0	0	0	0	006			
BOUNCE 16..1	P	A	B	D	D	D	D	D	D	D	D	D	D	D	D	D	D	D	D	D	E	F	C	G	H	1	1	1	0	0	0	0	0	007			
BOUNCE 32..17	P	A	B	D	D	D	D	D	D	D	D	D	D	D	D	D	D	D	D	D	E	F	C	G	H	0	0	0	1	0	0	0	0	010			
BOUNCE 48..33	P	A	B	D	D	D	D	D	D	D	D	D	D	D	D	D	D	D	D	D	E	F	C	G	H	1	0	0	1	0	0	0	0	011			
BOUNCE 64..49	P	A	B	D	D	D	D	D	D	D	D	D	D	D	D	D	D	D	D	D	E	F	C	G	H	0	1	0	1	0	0	0	0	012			
TEST 5'S	P	1	0	0	1	0	1	0	1	0	1	0	1	0	1	0	1	0	1	E	F	C	G	H	1	1	0	1	0	0	0	0	013				
TEST A'S	P	1	0	1	0	1	0	1	0	1	0	1	0	1	0	1	0	1	0	E	F	C	G	H	0	0	1	1	0	0	0	0	014				
BOUNCE 80..65	P	A	B	D	D	D	D	D	D	D	D	D	D	D	D	D	D	D	D	D	E	F	C	G	H	1	0	1	1	0	0	0	0	015			
BOUNCE 96..81	P	A	B	D	D	D	D	D	D	D	D	D	D	D	D	D	D	D	D	D	E	F	C	G	H	0	1	1	1	0	0	0	0	016			
DATA 16..1	P	A	B	D	D	D	D	D	D	D	D	D	D	D	D	D	D	D	D	D	E	F	C	G	H	1	1	1	1	0	0	0	0	017			
DATA 32..17	P	A	B	D	D	D	D	D	D	D	D	D	D	D	D	D	D	D	D	D	E	F	C	G	H	0	0	0	0	1	0	0	0	020			
DATA 48..33	P	A	B	D	D	D	D	D	D	D	D	D	D	D	D	D	D	D	D	D	E	F	C	G	H	1	0	0	0	1	0	0	0	021			
DATA 64..49	P	A	B	D	D	D	D	D	D	D	D	D	D	D	D	D	D	D	D	D	E	F	C	G	H	0	1	0	0	1	0	0	0	022			
DATA 80..65	P	A	B	D	D	D	D	D	D	D	D	D	D	D	D	D	D	D	D	D	E	F	C	G	H	1	1	0	0	1	0	0	0	023			
DATA 96..81	P	A	B	D	D	D	D	D	D	D	D	D	D	D	D	D	D	D	D	D	E	F	C	G	H	0	0	1	0	1	0	0	0	024			

Notes:

A B = 0 0 If there are no major faults.

A B = 1 1 If major faults exist (data is bad).

C = 0 When 429 data rate is 100 kbps; C = 1 When data rate is 12.5 kbps.

D = Data bit.

F = 1 If the discrete interface output has any major faults (429 data may still be good).

P = ARINC 429 parity bit.

E = 1 If there is a bit fault

G H = The value of these two locations will track channel 1 and 2 or can be hard-wired (via channel 1 and 2) to determine which R0D3 the 429 word came from.

The 20 words are transmitted in order shown from top to bottom.

contains the logic "1" serial transmission. These two signals must be connected to a 429 Line Driver (DD-03182) to obtain a single-ended ARINC 429 transmission signal. FIGURE 7 illustrates this interface.

The content and word order of the ARINC 429 transmission is shown in TABLE 6.

As noted, these features are only guaranteed and tested if the ARINC 429 option is selected. In addition, the clock frequency (1 MHz) must be selected carefully so as not to interfere with other avionic communications as detailed in ARINC 429. The ARINC 429 option bit rate is derived from the (1 MHz) clock. Refer to ARINC 429 Bit Rate to avoid interference. ARINC 429-14 (January 4, 1993), paragraph 2.4 "Timing Related Elements" contains a "COMMENTARY" section following subparagraph 2.1.4.2 ("Low-Speed Operation") that cautions against using "precisely" 100 kilobits per second.

429 LINE-DRIVER

If you use the 429 option for the DD-03296, you can use a line-driver chip to transmit the data on the serial data bus. DDC has such a device, the DD-03182, which will support ARINC 429, 571, and 575 bus standards (see TABLE 7), and is available in four package types as indicated in FIGURES 8, 9 and 10.

The serial data is presented on DATA (A) and DATA (B) inputs in a dual-rail format. The driver is enabled by the SYNC and CLOCK inputs. The output voltage level is programmed by the V_{REF} input and is normally tied to +5 VDC, along with V₁, to produce output levels of +5 V, 0 V and -5 V on each output for 10V differential outputs (see FIGURE 6).

The output resistance is 75 Ohms ±20%; 37.5 Ohms on each output. The outputs are fused for fail-safe protection against shorts to aircraft power. The output slew rate is controlled by external timing capacitors on C_A and C_B. Typical values are 75 pF for 100 kHz data and 500 pF for 12.5 kHz data.

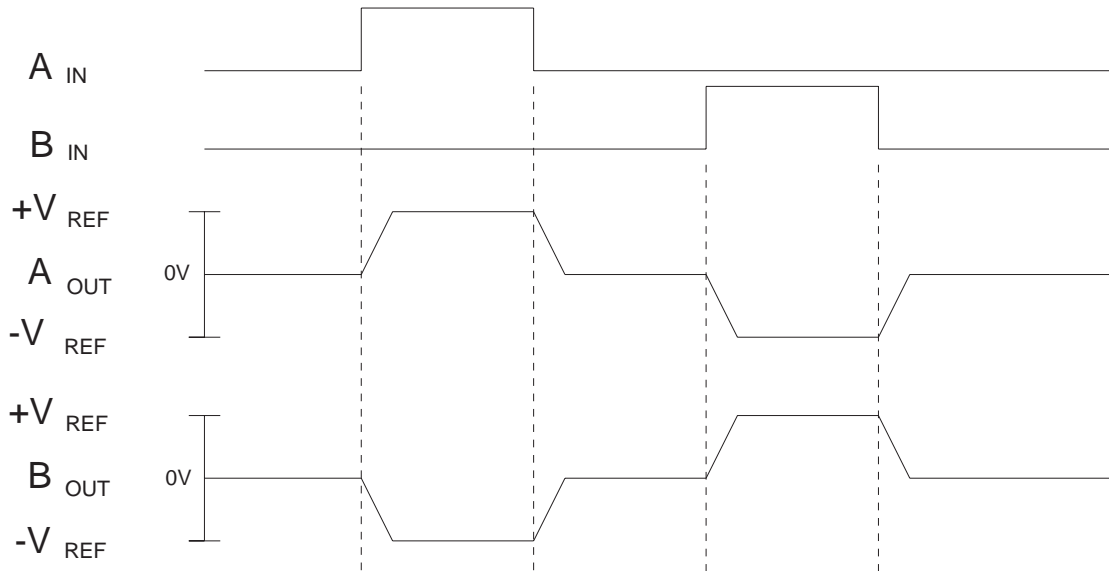

Note: The output slew rates are controlled by timing capacitors C_A and C_B . They are charged by $\pm 200 \mu\text{A}$ (nominal). Slew rate (SR) is calculated by $SR = 200/C$ (V/us) where C is in pF.

FIGURE 6. ARINC 429 WAVEFORM

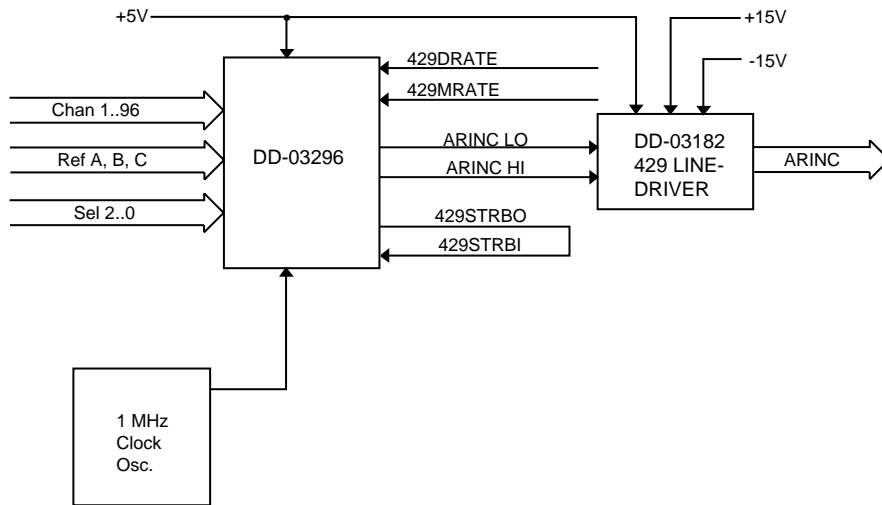

NOTE: 1) 429 MRATE and DRATE can either be tied to gnd or +5V (Refer to Page 8).

2) If the ARINC 429 option is not used, then pin 153 (429STRBI) MUST be grounded for the "bounce" circuit to operate properly.

FIGURE 7. DD-03296 TO ARINC 429 INTERFACE

DD-03182 LINE DRIVER PIN DESCRIPTIONS

See FIGURES 8, 9 and 10 for reference.

V_{REF} (Input) – the voltage on V_{REF} sets the output voltage levels on A_{OUT} and B_{OUT} . The output logic level swings between $+V_{REF}$ volts, 0 volts and $-V_{REF}$ volts.

N/C – No Connection

SYNC (Input) – Logic 0 will force outputs to NULL or MARK state. Logic 1 enables data transmission.

CLOCK (Input) – Logic 0 will force outputs to NULL or MARK state. Logic 1 enables data transmission.

DATA(A)/DATA(B) (Inputs) – Signals containing the serial data to be transmitted on the ARINC 429 data bus.

C_A/C_B (Analog) – External timing capacitors are tied from these points to ground to establish the output signal slew rate. Typically, $C_A = C_B = 75$ pF for 100 kHz data and $C_A = C_B = 500$ pF for 12.5 kHz data.

A_{OUT}/B_{OUT} (Outputs) – Line driver outputs which are connected to the aircraft serial data bus.

-V (Input) – Negative supply input (-15 VDC nominal).

GND – Ground.

+V (Input) – Positive supply input (+15 VDC nominal).

V_1 (Input) – Logic supply input (+5 VDC nominal).

TABLE 7. DD-03182 LINE DRIVER SPECIFICATIONS				
PARAMETER	UNITS	MIN	TYP	MAX
ABSOLUTE MAXIMUM RATINGS				
VOLTAGE BETWEEN PINS				
+V and -V	V			40
V_1 and GND	V			7
V_{REF} and GND	V			6
POWER SUPPLY REQUIREMENTS				
+V	VDC	11.4	15	16.5
-V	VDC	-11.4	-15	-16.5
V_1	VDC	4.75	5	5.25
V_{REF} (for ARINC 429)	VDC	4.75	5	5.25
V_{REF} (for other applications)	VDC	0		
THERMAL				
Operating Ambient Temperature				
Ceramic	°C	-55		+125
Plastic	°C	-40		+85
Storage Temperature	°C	-65		+150
Lead Temperature (localized 10 sec duration)	°C			+300
Thermal Resistance:				
Junction to Ambient θ_{ja}				
DD-03182DC	°C/W			75
DD-03182PP	°C/W			95
DD-03182GP	°C/W			115
DD-03182VP	°C/W			130
Junction Temperature	°C			175

Note: Refer to DD-03182 data sheet for more information.

DIMENSIONS ARE IN INCHES (mm)

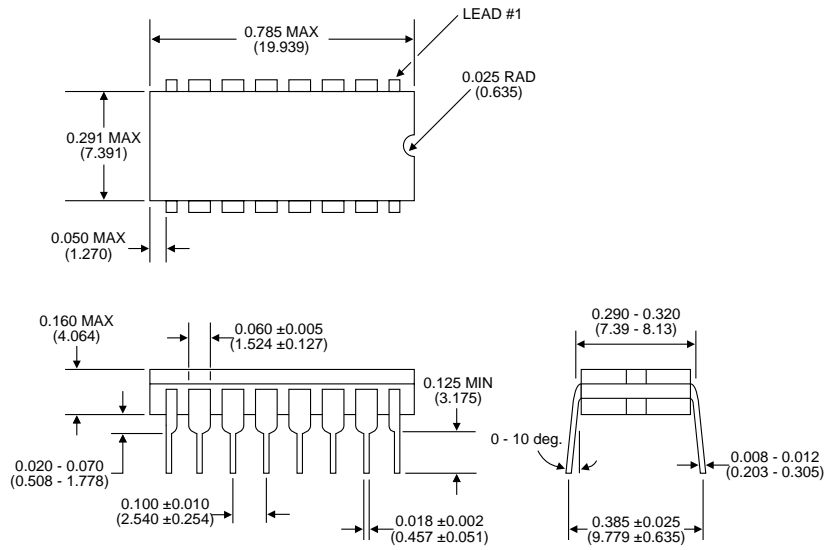

FIGURE 11. DD-03182DC 16-PIN CERAMIC DIP (JE) MECHANICAL OUTLINE

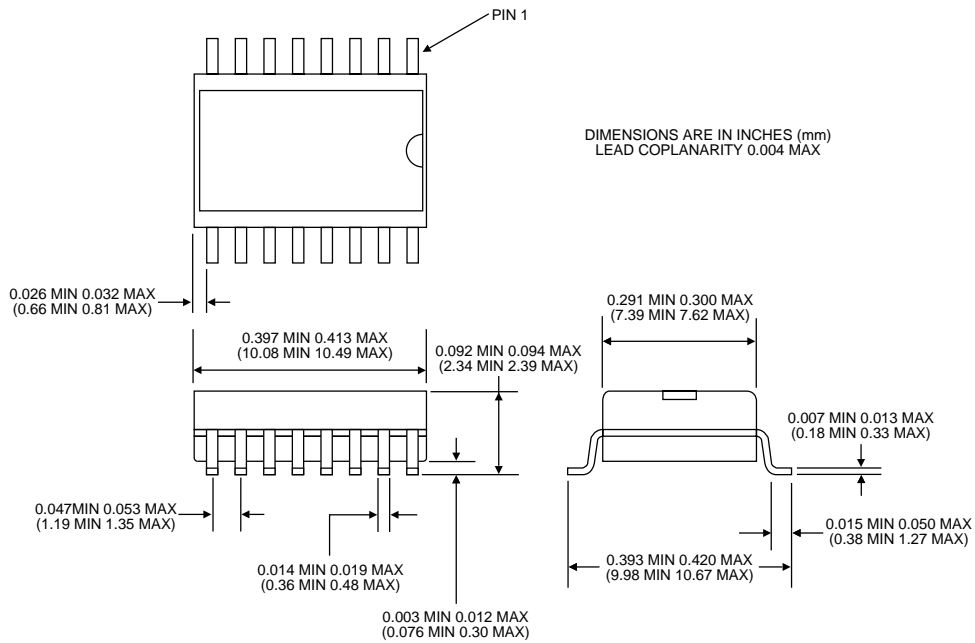

FIGURE 12. DD-03182GP 16-PIN SURFACE MOUNT (SOIC) MECHANICAL OUTLINE

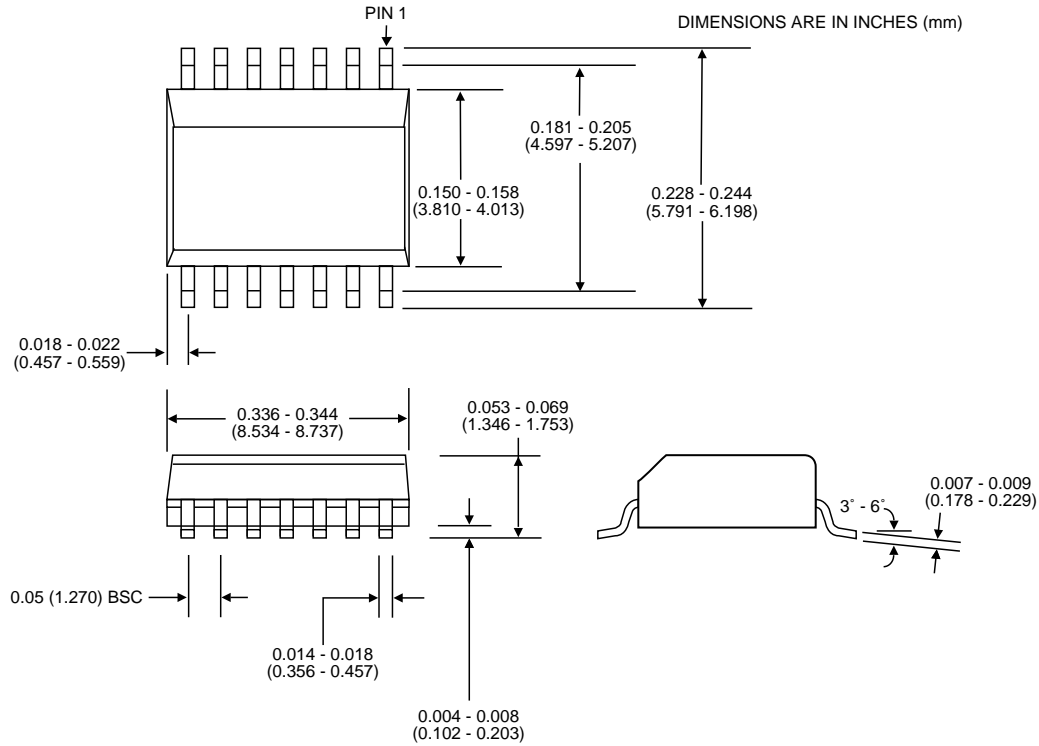
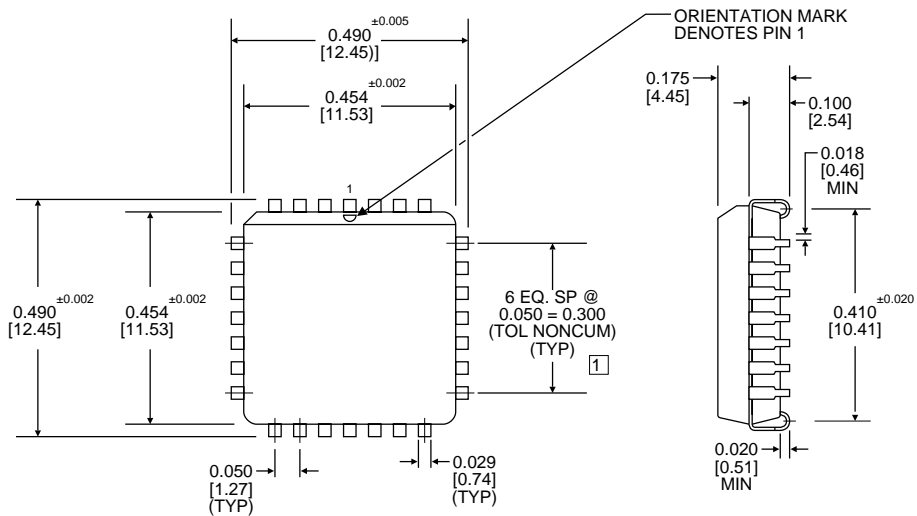

FIGURE 13. DD-03182VP 14-PIN SURFACE MOUNT (SOIC) MECHANICAL OUTLINE



- Notes: [1] LEAD CLUSTER TO BE CENTRALIZED ABOUT CASE CENTERLINE WITHIN ± 0.010 .
2. DIMENSIONS SHOWN ARE IN INCHES [MILLIMETERS].

FIGURE 14. DD-03182PP 28-PIN (PLCC) MECHANICAL OUTLINE

TABLE 8. DD-03296 PIN FUNCTIONS

PIN NUMBER	FUNCTION	PIN NUMBER	FUNCTION	PIN NUMBER	FUNCTION
1	CH_03	55	CH_41	109	CH_76
2	CH_04	56	CH_42	110	CH_75
3	CH_05	57	CH_43	111	CH_74
4	CH_06	58	CH_44	112	CH_73
5	CH_07	59	CH_45	113	N/C
6	CH_08	60	CH_46	114	N/C
7	N/C	61	CH_47	115	CH_72
8	CH_09	62	CH_48	116	CH_71
9	CH_10	63	N/C	117	CH_70
10	CH_11	64	TRIM: CH_65-96	118	CH_69
11	CH_12	65	REF: CH_65-96	119	CH_68
12	CH_13	66	CH_49	120	CH_67
13	CH_14	67	CH_50	121	CH_66
14	CH_15	68	CH_51	122	CH_65
15	CH_16	69	CH_52	123	D15
16	READY	70	CH_53	124	D14
17	N/C	71	CH_54	125	D13
18	N/C	72	CH_55	126	D12
19	CH_17	73	CH_56	127	D11
20	CH_18	74	TRIM: CH_33-64	128	D10
21	CH_19	75	REF: CH_33-64	129	D09
22	CH_20	76	CH_57	130	D08
23	CH_21	77	CH_58	131	D07
24	CH_22	78	CH_59	132	D06
25	CH_23	79	CH_60	133	D05
26	CH_24	80	CH_61	134	D04
27 (Note 1)	VDD (ANALOG)	81	CH_62	135	D03
28	1 MHz CLK	82	CH_63	136	D02
29	CH_25	83	CH_64	137	D01
30	CH_26	84	N/C	138	D00
31	CH_27	85	CH_96	139	A05
32	CH_28	86	CH_95	140	A04
33	CH_29	87	CH_94	141 (Note 1)	GND (DIGITAL)
34	CH_30	88	CH_93	142 (Note 1)	VDD (DIGITAL)
35	CH_31	89	CH_92	143	A03
36	CH_32	90	CH_91	144	A02
37	REF: CH_01-32	91	CH_90	145	A01
38	TRIM: CH_01-32	92	CH_89	146	A00
39 (Note 2)	$\overline{\text{TMODE}}$	93	N/C	147	$\overline{\text{ENABLE}}$
40 (Note 2)	$\overline{\text{TMUX}}$	94	N/C	148	$\overline{\text{FAULT}}$
41	$\overline{\text{RESET}}$	95	CH_88	149 (Note 2)	$\overline{\text{FMUX}}$
42	N/C	96	CH_87	150 (Note 2)	$\overline{\text{FMODE}}$
43	N/C	97	CH_86	151	ARINC_LO
44	N/C	98	CH_85	152	ARINC_HI
45	CH_33	99	CH_84	153 (Note 4)	429_STRBI
46	CH_34	100	CH_83	154	429_STRBO
47	CH_35	101	CH_82	155	429_MRATE
48	CH_36	102	CH_81	156	429_DRATE
49	CH_37	103 (Note 1)	GND (ANALOG)	157 (Note 3)	CLKTEST
50	CH_38	104	8/16 BITS	158	SEL0
51	CH_39	105	CH_80	159	SEL1
52	CH_40	106	CH_79	160	SEL2
53	N/C	107	CH_78	161	CH_01
54	N/C	108	CH_77	162	CH_02

Notes for TABLE 8:

1. VDD (Digital) and VDD (Analog) MUST be connected to the same power source; GND (Digital) and GND (Analog) MUST be connected to the same GND potential.
2. These signals should be tied to +5V.
3. DO NOT CONNECT
4. This pin must be grounded if 429 ARINC is not implemented.

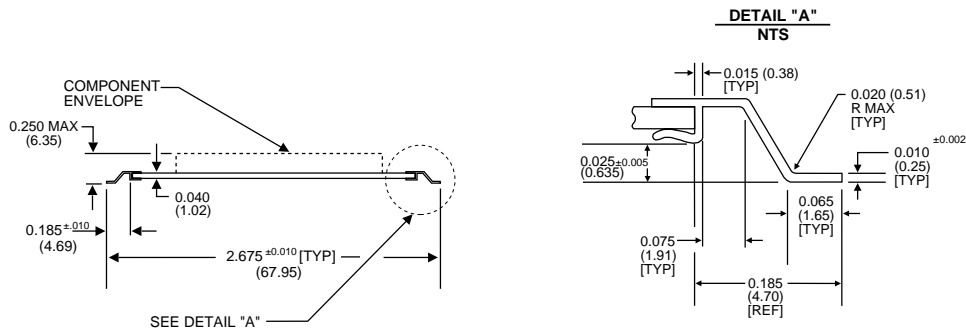
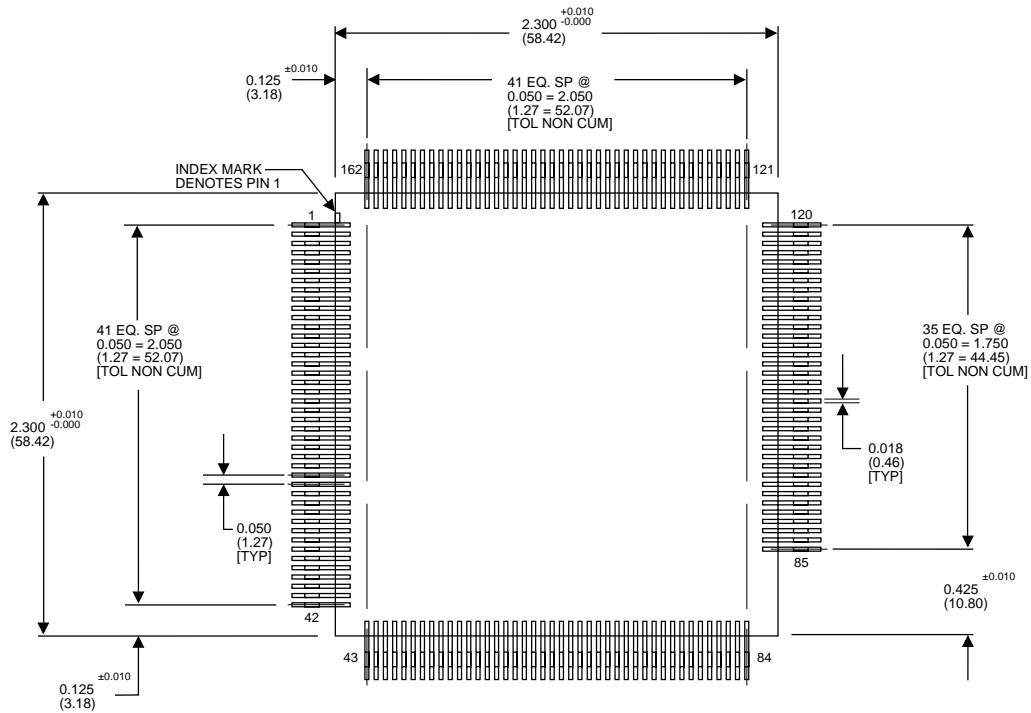

Note: Dimensions are in inches (millimeters).

FIGURE 15. DD-03296 MECHANICAL OUTLINE

ORDERING INFORMATION

DD-03296FP-XX0

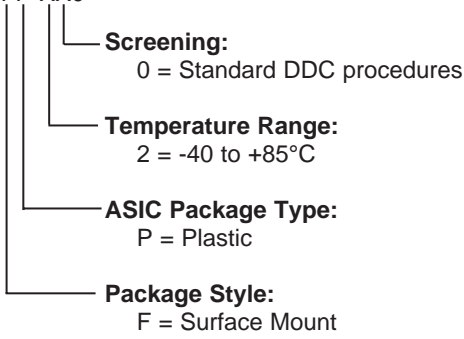

www.DataSheet4U.com

OPTIONAL HARDWARE

DD-03182XX-XXXX – ARINC 429 Line Driver

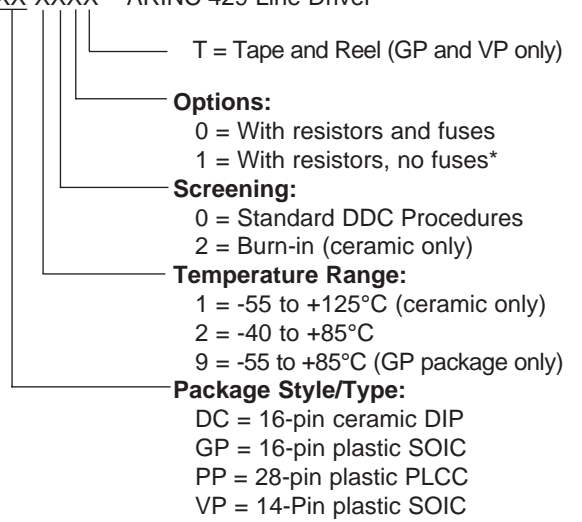

*VP version only.

OTHER APPLICABLE DOCUMENTS

RTCA/DO-160D: Environmental Conditions and Test Procedure for Airborne Equipment

The information in this data sheet is believed to be accurate; however, no responsibility is assumed by Data Device Corporation for its use, and no license or rights are granted by implication or otherwise in connection therewith. Specifications are subject to change without notice.



105 Wilbur Place, Bohemia, New York 11716-2482

For Technical Support - 1-800-DDC-5757 ext. 7402

Headquarters - Tel: (631) 567-5600 ext. 7402, Fax: (631) 567-7358

Southeast - Tel: (703) 450-7900, Fax: (703) 450-6610

West Coast - Tel: (714) 895-9777, Fax: (714) 895-4988

Europe - Tel: +44-(0)1635-811140, Fax: +44-(0)1635-32264

Asia/Pacific - Tel: +81-(0)3-3814-7688, Fax: +81-(0)3-3814-7689

World Wide Web - <http://www.ddc-web.com>



ILC DATA DEVICE CORPORATION
REGISTERED TO ISO 9001
FILE NO. A3976