

PIN DIAGRAM

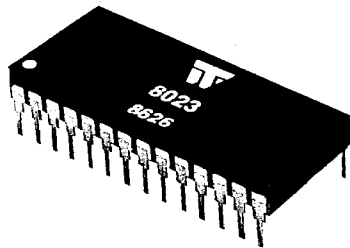
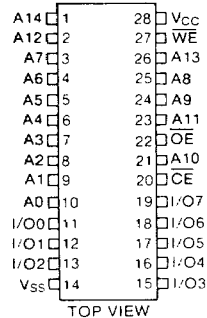

FEATURES

- Voltage: +5V and Gnd
- Operating Temperature: -55° to +200° C
- Operating Current: 10mA (Typ)
- Standby Current: 1.0mA (Typ)
- Programming Temp: -55° to +180° C
- Access Time: 250nS

BLOCK DIAGRAM

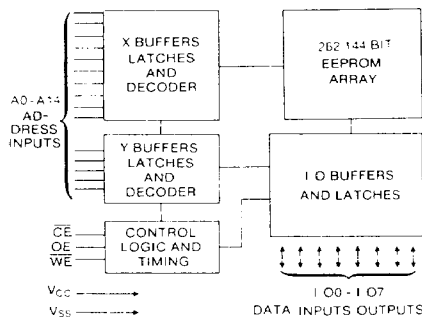

DESCRIPTION

The Bowmar/White Technology 8023 is a low-power, high-performance 32K x 8 bit non-volatile Electrically Erasable and Programmable Read Only Memory with popular, easy to use features, with data retention and readability to +200° C; and programmability to +180° C.

The 8023 is accessed like a static RAM for the read or write cycles without the need of external components. During a "byte write," the address and data are latched internally, freeing the microprocessor address and data bus for other operations. Following the initiation of a write cycle, the device will go to a busy state and automatically clear and write the latched data using an internal control timer. The device includes a method for detecting the end of a write cycle, DATA polling of I/O7. Once the end of a write cycle has been detected, a new access for a read or write can begin.

The CMOS technology offers fast access times of 250nS at low power dissipation. When the chip is deselected, the standby current is less than 1.0mA.

EEPROM Characteristics

Sym	Parameter (At 125° C)	Min	Typ	Max	Units
I _{ii}	Input Load Current			20	μA
I _{io}	Output Leakage Current			20	μA
I _{sb}	V _{CC} Standby Current CE = V _{CC}			44	μA
I _{CC}	V _{CC} Active Current f = 5MHz			10	mA
V _{il}	Input Low Voltage	-0.1		0.8	V
V _{ih}	Input High Voltage	2.0		V _{CC} +1	V
V _{ol}	Output Low Voltage			.45	V
V _{oh}	Output High Voltage	2.4			V
C _{in}	Capacitance		65	75	pF
C _{out}	Capacitance		80	100	pF
	Access Time at 125° C			150	nS
	Access Time at 200° C			250	nS
	Endurance	10000 Write Cycles			
	Data Retention	10 Years			

TRUTH TABLE

CE	OE	WE	MODE	I/O	POWER
L	L	H	Read	Dout	Active
L	H	L	Write	Din	Active
H	X	X	Standby/Write Inhibit	High Z	Standby
X	L	X	Write Inhibit	—	—
X	X	H	Write Inhibit	—	—

32K x 8 BIT PROGRAMMABLE EPROM—8023

DEVICE OPERATION

READ

The 8023 is accessed like a static RAM. When \overline{CE} and \overline{OE} are low and \overline{WE} is high, the data stored at the memory location determined by the address pins is asserted on the outputs. The outputs are put in a high impedance state whenever \overline{CE} or \overline{OE} is high. This dual line control gives designers increased flexibility in preventing bus contention.

BYTE WRITE

Writing data into the 8023 is similar to writing into a static RAM. A low pulse on the \overline{WE} or \overline{CE} input with \overline{OE} high and \overline{CE} or \overline{WE} low (respectively) initiates a byte write. The address location is latched on the falling edge of \overline{WE} (or \overline{CE}); the new data is latched on the rising edge. Internally the device performs a self-clear before write. Once a byte write has been started, it will automatically time itself to completion. Write cycle is 1mS max.

DATA POLLING

The 8023 also utilizes \overline{DATA} POLLING to signal the completion of a write cycle. During a write cycle, an attempted read of the data being written results in the compliment of that data for I/O7 (the other outputs are indeterminate). When the write cycle is finished, true data appears on all outputs.

WRITE PROTECTION

Inadvertent writes to the device are protected against in the following ways: (a) V_{CC} sense—if V_{CC} is below 3.8V, the write function is inhibited. (b) V_{CC} power on delay—once V_{CC} has reached 3.8V, the device will automatically time out 5mS before allowing a byte write. (c) Write Inhibit—holding any one of \overline{OE} low, \overline{CE} high or \overline{WE} high inhibits byte write cycles.

TIMING DIAGRAMS

WRITE CYCLE

All times are maximums unless otherwise specified.

READ CYCLE

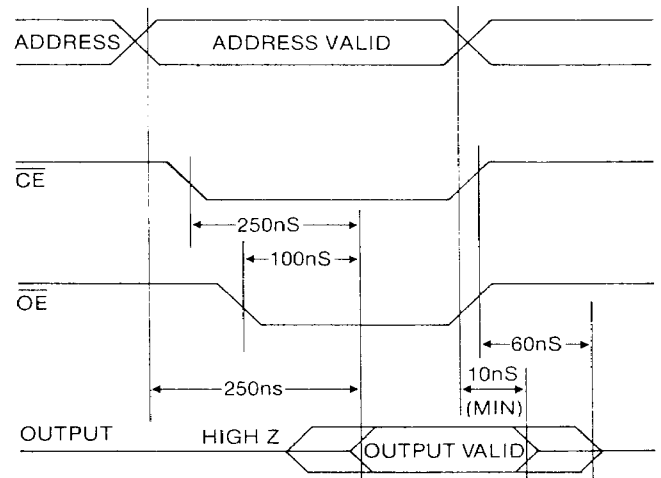
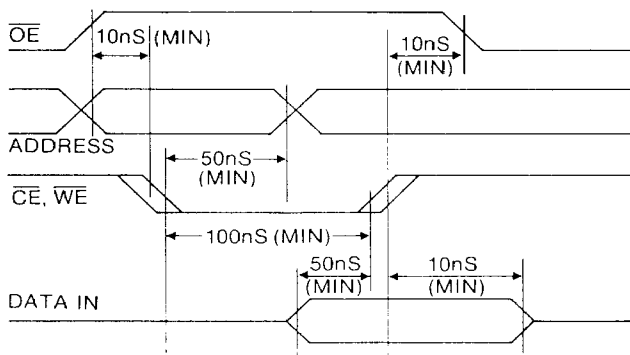

CASE OUTLINE

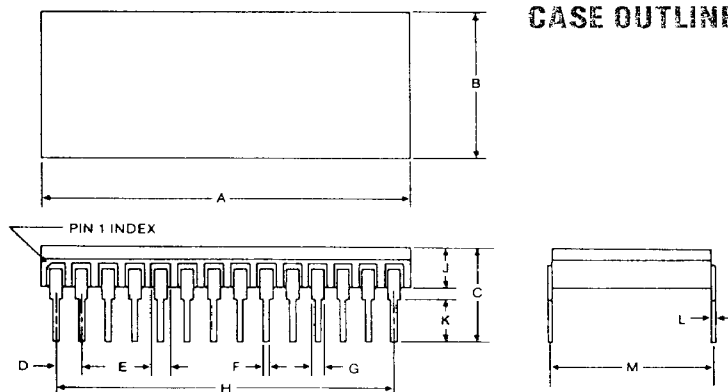

DIM	INCHES		MILLIMETERS	
	MIN	MAX	MIN	MAX
A	1.250	1.550	31.8	39.4
B	0.600	0.620	15.2	15.8
C	0.375 REF.		9.5 REF.	
D	0.098	0.102	2.5	2.6
E	0.065	0.075	1.7	1.9
F	0.016	0.020	0.4	0.5
G	0.048	0.052	1.2	1.3
H	1.294	1.306	32.9	33.2
J	0.138	0.172	3.5	4.4
K	0.160	0.180	4.1	4.6
L	0.008	0.012	0.2	0.3
M	0.600 REF.		15.2 REF.	

Bowmar/White Technology

4246 EAST WOOD ST. • PHOENIX, AZ 85040
TEL: 602-437-1520 • TWX: 910-951-4203