

Overview

- The UM (Ultra-Miniature) series consists of ultrasmall-size coaxial connectors that are most suitable for very thin coaxial cables having a high reliability.
- Two types of lock are available: the screw-lock type and the quick-lock type. The quick-lock type has been approved in Defense Agency standards NDS XC6115 and DSP C6205.
- Two connecting methods are available: the solderless connecting system, in which the simplicity and accuracy of the work of connecting the wiring is greatly increased; and the screw-clamp system, in which wires can be connected accurately.

Main materials used

Part	Materials	Finish
Shell	Brass	Gold plating
Male contact	Brass	Gold plating
Female contact	Beryllium copper	Gold plating
Insulation	Tetrafluoride resin	

Main performance characteristics

Items	Standard value
Contact resistance	5mΩ or less (at 1A DC)
Insulation resistance	1000MΩ or more at 500V DC
Withstand voltage	500V AC (rms) for 1 minute
Characteristic impedance	50Ω
Voltage standing wave ratio	1.2 or less at DC ~ 1000MHz

UM-P plugs

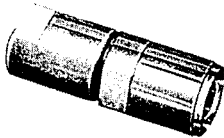

UM-QP-196/U

Fig.1

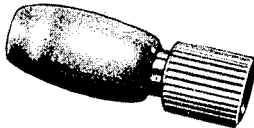
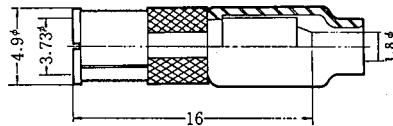

UM-SP-1.5

Fig.2

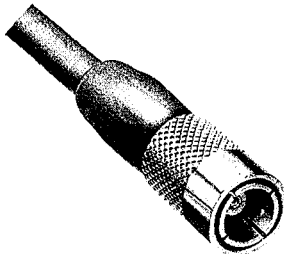
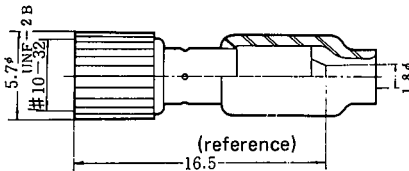

UM-QP-1.5CR3(02)

Fig.3

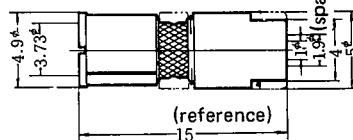
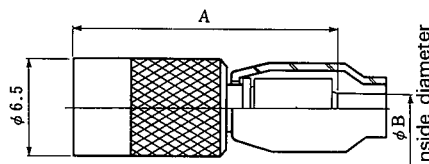

Fig.4



HRS No.	Part No.	Applicable cable	A	φ B	Shape
318-0001-6	UM-QP-1.5	1.5D-2V	—	—	Fig.1
318-0005-7	UM-SP-1.5	1.5D-2V	—	—	Fig.2
318-0013-5	UM-QP-196/U	RG-196A/U	—	—	Fig.3
318-0098-8-02	UM-QP-1.5CR3(02)	1.5D-2V	18	1.8	Fig.4
* 318-0190-0	UM-QP-1.5WCR3A	1.5D-2V	18.8	1.8	Fig.4
318-0099-0	UM-QP-1.5WCR3	1.5D-2W	18	1.8	Fig.4
* 318-0176-0	UM-QP-1.5WCR3A	1.5D-2W	18.8	1.8	Fig.4
318-0102-3	UM-QP-2.5CR3	2.5D-2V	18.6	2.8	Fig.4
* 318-0164-0	UM-QP-2.5CR3A	2.5D-2V	21	2.8	Fig.4
318-0115-5	UM-QP-2.5WCR3	2.5D-2W	18.5	2.8	Fig.4

※ Center contact fix type

UM SERIES RF CO-AXIAL CONNECTORS

L-shaped plug

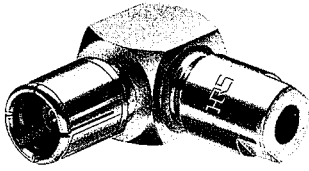

UM-QLP-196/U

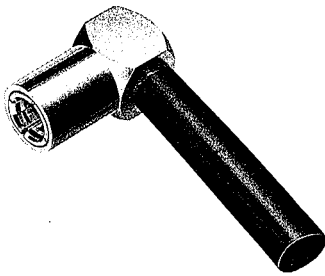
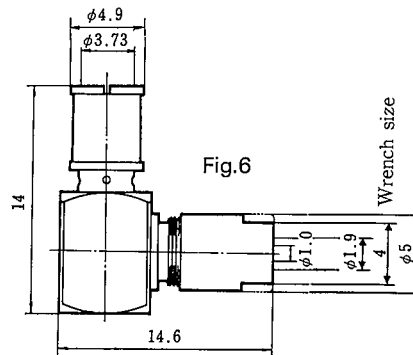
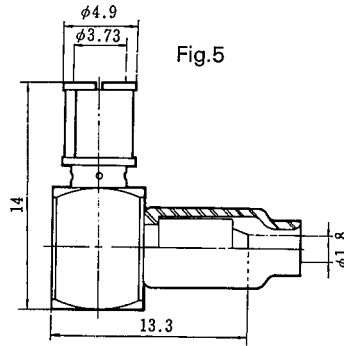

UM-QLP-1.5-6

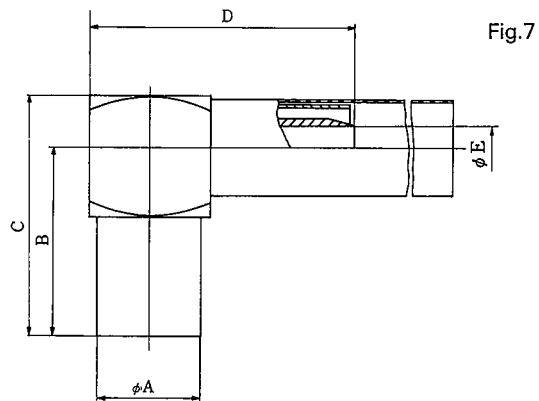

HRS No.	Part No.	Applicable cable	A	B	C	D	φE	Shape
318-0009-8	UM-QLP-1.5	1.5D-2V	—	—	—	—	—	Fig.5
318-0014-8	UM-QLP-196/U	RG-196A/U	—	—	—	—	—	Fig.6
318-0162-5	UM-QLP-1.5-6	1.5D-2V	6.3	10.4	13.3	14.1	1.8	Fig.7
318-0163-8	UM-QLP-1.5W-6	1.5D-2W	6.3	10.4	13.3	14.1	1.8	Fig.7
318-0082-8(01)	UM-QLP-2.5CR4(01)	2.5D-2V	6.5	10.3	13.6	16.6	2.8	Fig.7
318-0085-6	UM-QLP-2.5WCR1	2.5D-2W	6.5	10.3	13.6	16.6	2.8	Fig.7

UM SERIES

RF CO-AXIAL CONNECTORS

UM-J jacks



UM-SJ-1.5

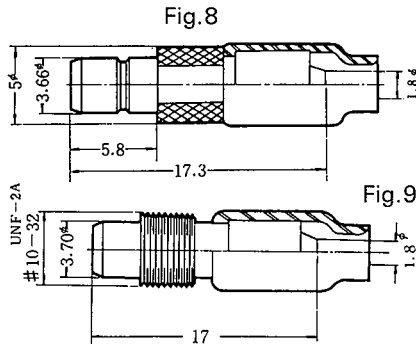

HRS No.	Part No.	Applicable cables	Remarks
*CL318-0003-1	UM-QJ-1.5	1.5D-2V	Fig. 8
CL318-0007-2	UM-SJ-1.5	1.5D-2V	Fig. 9
CL318-0015-0	UM-QJ-196/U	RG-196/U	Fig. 10

*Standard product

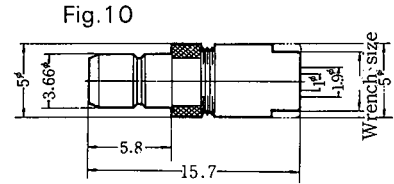

UM-PJ panel jacks

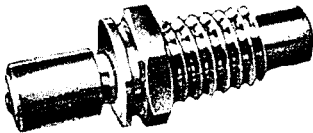

UM-SPJ-1.5

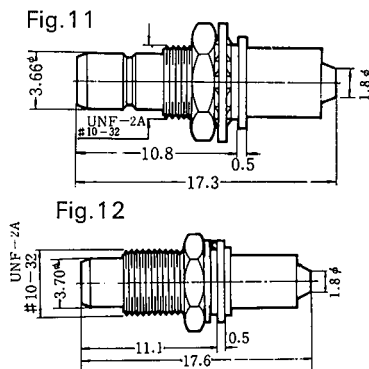

HRS No.	Part No.	Applicable cables	Remarks
*CL318-0004-4	UM-QPJ-1.5	1.5D-2V	Fig. 11
CL318-0008-5	UM-SPJ-1.5	1.5D-2V	Fig. 12
CL318-0016-3	UM-QPJ-196/U	RG-196/U	Fig. 13

*Standard product

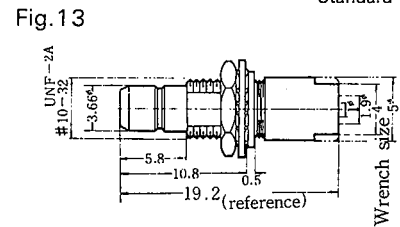

UM-R receptacles

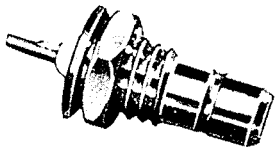

UM-QR

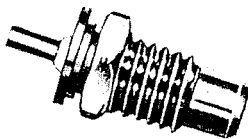
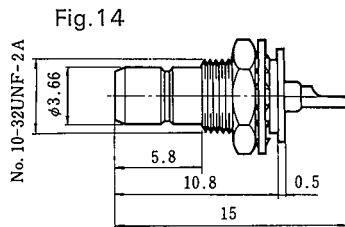

UM-SR

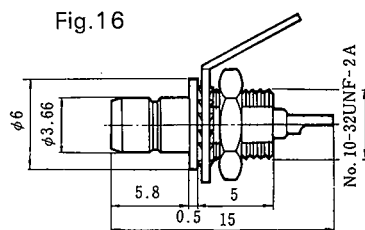
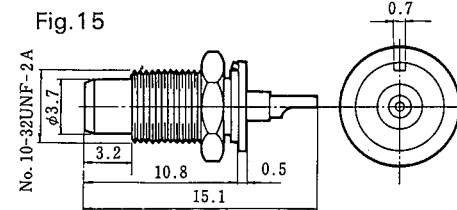

HRS No.	Part No.	Remarks
*CL318-0002-9	UM-QR	Fig. 14
*CL318-0006-0	UM-SR	Fig. 15
*CL318-0011-0	UM-QR-1	Fig. 16
CL318-0066-1	UM-QR-8	Fig. 17

* Standard

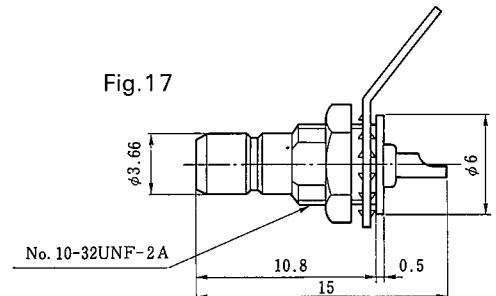

UM SERIES RF CO-AXIAL CONNECTORS

UM-A linear adapters



UM-QA-JJ

Fig.18

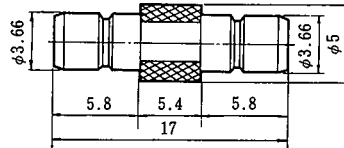

HRS No.	Part No.
CL318-0012-2	UM-QA-JJ

Receptacles (type for mounting printed circuit boards)

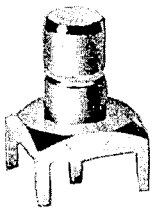

UM-R-PC

Fig.19

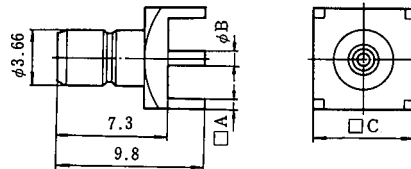

HRS No.	Part No.	A	B	C
*CL318-0032-0	UM-R-PC	0.7	1	6.7
CL318-0054-2	UM-R-PC-1	0.6	0.8	5.7
CL318-0067-4	UM-R-PC-7	0.6	1	6.5

* Standard product

L-type receptacle (type for mounting printed circuit boards)

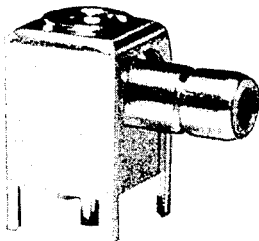

UM-LR-PC

Fig.20

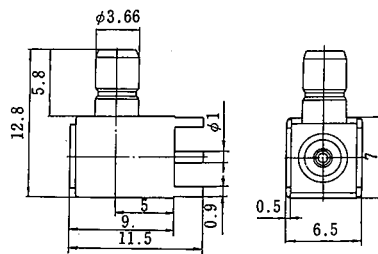

HRS No.	Part No.	Sharp	Remarks
*CL318-0033-2	UM-LR-PC	Fig.20	—
CL318-0150-6	UM-LR-PC-4	Fig.21	

* Standard product

Fig.21

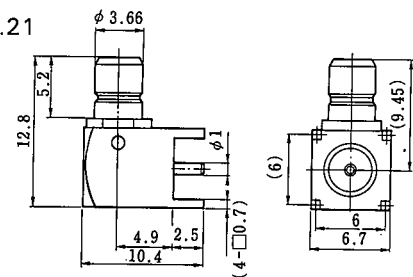

T-type receptacle (type for mounting printed circuit boards)

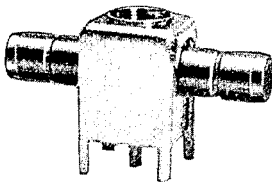

UM-TR-PC

Fig.22

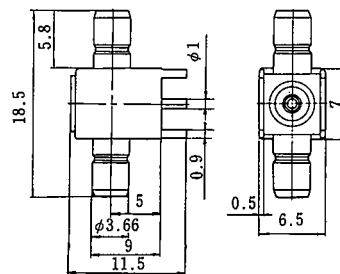

HRS No.	Part No.
CL318-0034-5	UM-TR-PC

UM SERIES RF CO-AXIAL CONNECTORS

Plug receptacle (type for mounting printed circuit boards)

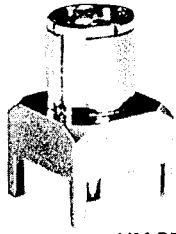

UM-PR-PC

Fig.23

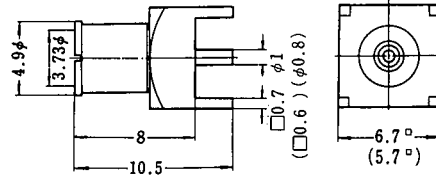

HRS No.	Part No.	Remarks
CL318-0036-0	UM-PR-PC	6.7 □
CL318-0118-3	UM-PR-PC-1	5.7 □

UM Series Plating Specifications List

The UM series are available with the center contact gold-plated or silver-plated, and outer contact gold-plated or nickel-plated. Plating specifications by part numbers are as follows :

Type	Part No.	HRS No.	Center		Outer		Type	Part No.	HRS No.	Center		Outer		
			Gold	Silver	Gold	Nickel				Gold	Silver	Gold	Nickel	
Plug	UM-QP-1.5	318-0001-6	○		○		Jack	UM-QJ-1.5	318-0003-1	○		○		
	UM-QP-1.5(01)	318-0001-6-01	○			○		UM-QJ-1.5(02)	318-0003-1-02	○			○	
	UM-SP-1.5	318-0005-7	○		○			UM-QJ-1.5	318-0007-2	○		○		
	UM-QP-196/U	318-0013-5	○		○			UM-QJ-196/U	318-0015-0	○		○		
	UM-QP-196/U(01)	318-0013-5-01	○			○		Panel jack	UM-QPJ-1.5	318-0004-4	○		○	
	UM-QP-1.5CR3	318-0098-8	○			○	UM-QPJ-1.5(01)		318-0004-4-01	○			○	
	UM-QP-1.5CR3(02)	318-0098-8-02		○		○	UM-SPJ-1.5		318-0008-5	○		○		
	UM-QP-1.5CR3(03)	318-0098-8-03	○		○		UM-QPJ-196/U		318-0016-3	○		○		
	UM-QP-1.5VCR3A	318-0190-0	○			○	UM-QPJ-196/U(01)		318-0016-3-01	○			○	
	UM-QP-1.5WCR3	318-0099-0	○			○	Adapter	UM-QA-JJ	318-0012-2	○		○		
	UM-QP-1.5WCR3A	318-0176-0	○			○		UM-QA-JJ(01)	318-0012-2-01	○			○	
	UM-QP-2.5CR3	318-0102-3	○			○	for PC board	Rese pta cle	UM-R-PC	318-0032-0	○		○	
	UM-QP-2.5CR3(02)	318-0102-3(02)		○		○			UM-R-PC(02)	318-0032-0-02	○			○
	UM-QP-2.5CR3(03)	318-0102-3(03)	○		○				UM-R-PC-1	318-0054-2	○		○	
	UM-QP-2.5CR3A	318-0164-0		○		○			UM-R-PC-1(01)	318-0054-2-01	○			○
UM-QP-2.5WCR3	318-0115-5		○		○	UM-R-PC-7			318-0067-4		○		○	
UM-QP-2.5WCR3	318-0115-5-01	○			○	UM-R-PC-7(01)		318-0067-4-01	○			○		
L-shaped plug	UM-QLP-1.5	318-0009-8	○		○			L- shaped rece ptacle	UM-LR-PC	318-0033-2	○		○	
	UM-QLP-1.5(01)	318-0009-8-01	○			○			UM-LR-PC(01)	318-0033-2-01	○			○
	UM-QLP-196/U	318-0014-8	○		○				UM-LR-PC-4	318-0150-6	○		○	
	UM-QLP-196/U(01)	318-0014-8-01	○			○			UM-LR-PC-4(01)	318-0150-6(01)	○			○
	UM-QLP-1.5W-6	318-0162-5	○			○	UM-LR-PC-4(02)		318-0150-6(02)		○		○	
	UM-QLP-1.5W-6	318-0163-8	○			○	UM-TR-PC		318-0034-5	○		○		
	UM-QLP-2.5CR4(01)	318-0082-8-01	○			○	Plug rese ptacle		UM-PR-PC	318-0036-0	○		○	
UM-QLP-2.5WCR1	318-0085-6	○			○	UM-PR-PC(01)		318-0036-0-01	○			○		
Receptacle	UM-QR	318-0002-9	○		○			UM-PR-PC(02)	318-0036-0-02		○		○	
	UM-QR(01)	318-0002-9-01	○			○		UM-PR-PC-1	318-0118-3	○		○		
	UM-SR	318-0006-0	○		○			UM-PR-PC-1(01)	318-0118-3-01		○		○	
	UM-SR(01)	318-0006-0-01	○			○								
	UM-QR-1	318-0011-0	○		○									
	UM-QR-1(01)	318-0011-0-01	○			○								
	UM-QR-8	318-0066-1		○		○								

Connecting methods

Solderless connecting system

Part No.	A	B
UM-QP -1.5	4.7	2.7
UM-QLP-1.5	4.7	1.1
UM-QJ -1.5	4.7	2.7
UM-QPJ-1.5	4.7	2.7

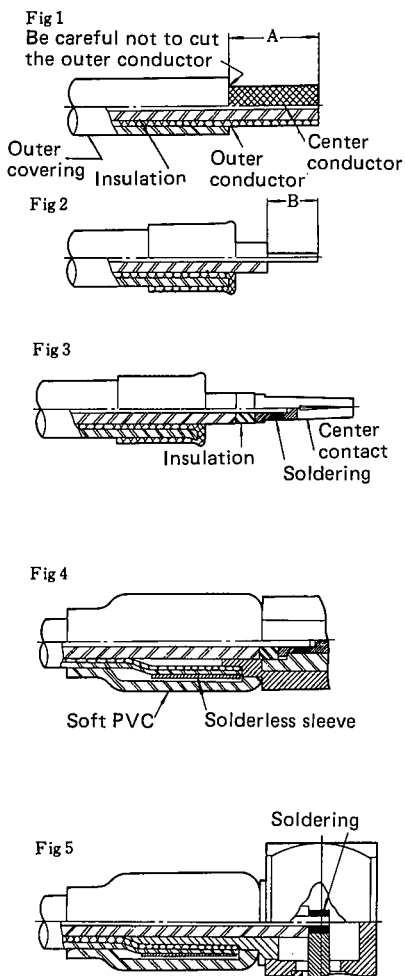

1. Cut the outer covering as shown in the drawing on the left.
2. Insert the soft PVC and solderless sleeve, in that order, onto the cable. Fold back the outer conductor, and cut the insulator to obtain the dimensions indicated in B.
3. Insert the insulation into the center conductor of the cable. Next insert the center conductor into the center contact and solder it. (Be careful to avoid any solder build-up.)
4. Insert this block into the plug. Insert the solderless sleeve, and crimp it with the proper tool. (As indicated) Cut off any of the outer conductor which is left outside the solderless sleeve at this time.

Note: In the case of UM-QP-1.5, it is advisable to insert this block into the plug with the plug locator (UM-QP-T) fitted into position.

Dedicated fixture UM-MSS-T-1

5. Finally, insert the soft PVC.
6. In UM-QLP-1.5, after everything has been done up to Fig. 2, insert into the plug and then perform 4 and 5.
7. Put the cable core into the split part of the center contact and solder it. (Be careful to avoid any solder build-up.)

Clamping system

Part No.	A	B	C
UM-QP -196/U	4.0	2.7	1.0
UM-QLP-196/U	6.5	1.1	5.0
UM-QJ -196/U	4.0	2.7	1.0
UM-QPJ-196/U	4.0	2.7	1.0

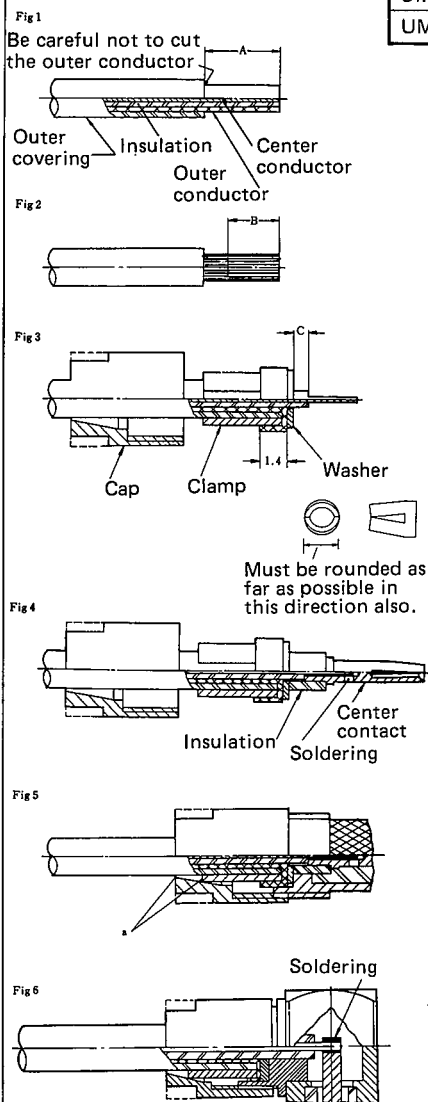

1. Cut the outer covering as shown in the drawing on the left.
 2. Disentangle the outer conductor, and cut the insulation as shown in the drawing on the left.
 3. Pass the cable through the cap, insert the clamp, and fold back the outer conductor as is shown in the drawing on the left. Cut the outer conductor at 1.4mm after inserting the washer. (The C dimensions are approximately the dimensions given in the table above.) (Tighten the clamp in the direction of the split.)
 4. Insert the insulation in front of the washer, insert the center contact into the core of the cable, and solder it. (Be careful to avoid any solder build-up.)
 5. Insert the insulation.
 6. Insert this block into the plug and tighten the cap until they match at part "a."
- Note: In the case of UM-QP-196/U, it is advisable to insert this block into the plug with the plug locator (UM-QP-T) fitted into position.
7. In UM-QLP-196/U, after everything has been done up to Fig. 3, insert into the plug and then tighten the cap thoroughly.
 8. Put the cable core into the split part of the center contact and solder it. (Be careful to avoid any build-up of solder.)

Drawings of holes drilled for panel mounting

Mounting holes for

UM-QR,
UM-QPJ-1.5,
UM-SR,
UM-SPJ-1.5,
UM-QPJ-196/U,

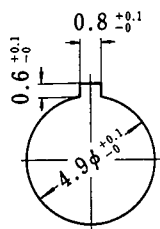

Mounting holes for UM-QR-1 UM-QR-8

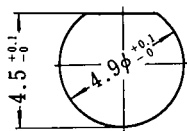

For printed circuit boards

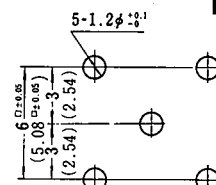

UM-R-PC, UM-PR-PC, UM-LR-PC, UM-LR-PC-4
Note: UM-R-PC-1, UM-PR-PC-1 are also available with the dimensions given in parenthesis.

UM SERIES RF CO-AXIAL CONNECTORS

1. UM-QP-1.5CR3 (02), UM-QP-2.5CR3 (02)

Fig. 1

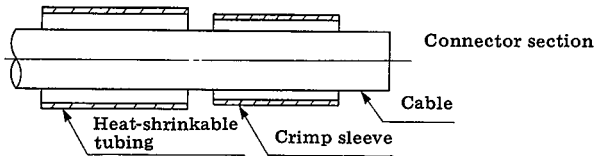

1. Mounting the heat-shrinkable tubing, crimp sleeve ----- Fig. 1. Mount the heat-shrinkable tubing and crimp sleeve in the cable as shown in Fig. 1.

Fig. 2

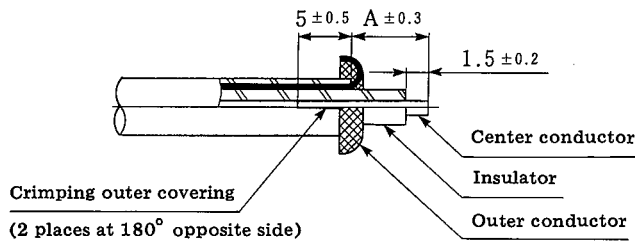

2. Cable end processing ----- Fig. 2. Process the cable ends as shown in Fig. 2. Dimension A shown under

Part No.	A
UM-QP-1.5CR3 (02)	6.8
UM-QP-2.5CR3 (02)	5.6

Note: Be careful not to damage the outer conductor or center conductor of the cable.

Fig. 3

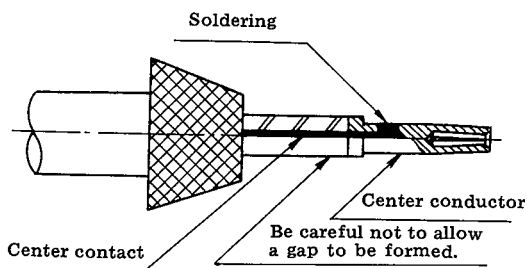

3. Solder the center contact ----- Fig. 3
 - (1) Solder the solder hole of center contact.
 - (2) Insert cable center conductor into the solder hole and solder it.

Note 1: Be careful when soldering not to melt the cable insulator when soldering.
Note 2: Remove the extra solder by knife where the solder is applied.

Fig. 4

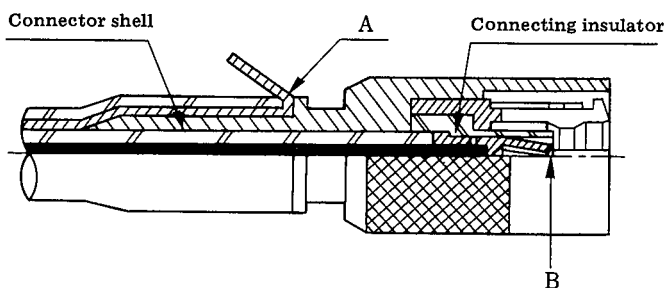

4. Insert the cable into the connector ----- Fig. 4.
 - (1) Insertion of cable is finished when the tip of center contact strikes against the connecting insulator at B section.
 - (2) Cut off the outer conductor by knife blade if it appears beyond A part.

UM SERIES RF CO-AXIAL CONNECTORS

Fig. 5

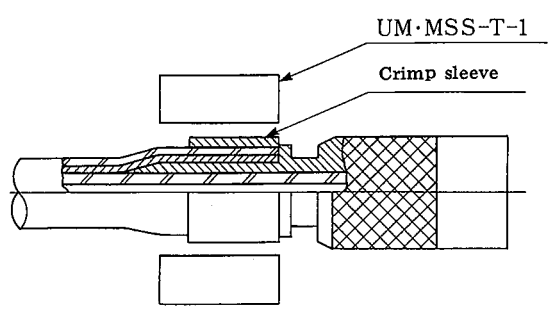

5. Crimping the crimp sleeve Fig. 5.
 (1) Move the crimp sleeve to the position as shown in figure.
 (2) Using the proper tool (UM, MSS-T-1), crimp it under showing holes.

Part No.	Dφ
UM-QP-1.5CR3(02)	1.5
UM-QP-2.5CR3(02)	2.5

Fig. 6

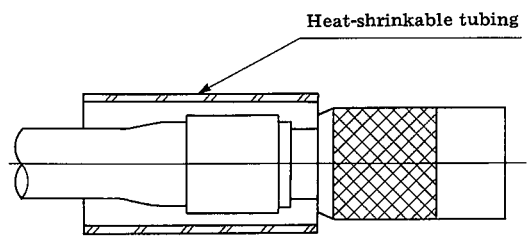

6. Shrink of heat-shrinkable tubing Fig. 6.
 Apply heat by means of a heat gun or like after the heat-shrinkable tubing is fitted to connector.

UM SERIES RF CO-AXIAL CONNECTORS

List of Connection Tools

Working tools by applicable cable for the UM series are as listed in a table below.

Applicable cable	Part No.	Connecting tool name	
		For outer conductor	Lid press-fitting rod
1.5D-2V	UM-QP-1.5	UM, MSS-T-1	—
	UM-SP-1.5	UM, MSS-T-1	—
	UM-QP-1.5CR3	UM, MSS-T-1	—
	UM-QP-1.5VCR3A	UM, MSS-T-1	—
	UM-QLP-1.5	UM, MSS-T-1	—
	UM-QLP-1.5-6	UM, MSS-T-1	UM-T-1
	UM-QJ-1.5	UM, MSS-T-1	—
	UM-SJ-1.5	UM, MSS-T-1	—
	UM-QPJ-1.5	UM, MSS-T-1	—
	UM-SPJ-1.5	UM, MSS-T-1	—
1.5D-2W	UM-QP-1.5WCR3	PO-P-2-T	—
	UM-QP-1.5WCR3A	PO-P-2-T	—
	UM-QLP-1.5W-6	PO-P-2-T	UM-T-1
2.5D-2V	UM-QP-2.5CR3	UM, MSS-T-1	—
	UM-QP-2.5CR3A	UM, MSS-T-1	—
	UM-QLP-2.5CR4	UM, MSS-T-1	UM-T-2
2.5D-2W	UM-QP-2.5WCR3	HRM-T-4	—
	UM-QLP-2.5WCR1	HRM-T-4	UM-T-2