

## Features

- Current Bias/Current Sense Architecture
- 3.3 or 5V Supply
- 3.3V CMOS Compatible Logic Interface
- Power Management
- Integrated Reference Resistor
- Single-ended Input to Reader with One Side Grounded Externally
- Differential Read Output
- GMR Resistor Range: 25Ω to 65Ω
- Programmable 5-bit GMR Head Bias Current:  $I_b = 2 \text{ mA} - 9.75 \text{ mA}$
- Programmable Gain Control: 130V/V & 200V/V @  $R_{mr} = 35\Omega$ ,  $I_b = 6 \text{ mA}$
- Wide Bandwidth: BW = 150 MHz at -3dB @  $R_{mr} = 35\Omega$
- Programmable Booster for Wide Bandwidth
- Equivalent Input Noise:  $V_n = 0.8 \text{ nV}/\sqrt{\text{Hz}}$  @  $R_{mr} = 35\Omega$
- Impedance Matched Differential Inputs for WDX and WDY
- Programmable 5-Bit Write Head Current:  $I_w = 15 \text{ mA}$  to 60 mA
- Servo Bank Write Mode
- Rise/Fall Time: 1 ns @ 5V and 2 ns @ 3.3V Typical  
( $I_w = 40 \text{ mA}$  (0-p),  $L_{ff} = 50 \text{ nH}$ ,  $R_{ff} = 15\Omega$ )
- Fast Recovery Times: W/R = 200 ns @ 5V Supply and W/R = 400 ns @ 3.3V Supply
- Programmable Write Current Overshoot Control
- Read Fault and Write Fault Detection
- $R_{mr}$  Value Measurement Mode
- GMR Head Open/Short and TF Head Protection
- Programmable (7 bits) Thermal Asperity Detection Threshold Control and Programmable Thermal Asperity Compensation
- Serial Port Read Back Capability
- GMR ESD Protection Diodes on Reader
- Internal Capacitor
- Available in a Variety of Packages Depending on Customer Requirements

## Description

The AT78C6002 is a BiCMOS 2-channel GMR Preamplifier device (also available as a 1-channel device, AT78C6001). They are designed for use with 4-terminal magneto-resistive recording heads, providing a low noise GMR head amplifier, GMR bias current control, thin film write driver, write current control, thermal asperity detection and correction. The fast recovery mode can be also programmed to put the chip in read mode faster than any other existing modes. The device provides programmable read gain, GMR resistance measurement, and thermal asperity threshold level. The device allows multiple channel write functions for servo writing. Half or all of the heads can be simultaneously selected in the servo write mode. Features and thresholds are controlled through a serial port interface. This product requires +3.3V or +5V supply voltage. It is available in Flip-chip or TSSOP packages.



## 2-Channel 3.3V or 5V GMR Head Preamplifier

AT78C6002

## Summary

3440AS-NETST-2/04



Note: This is a summary document. A complete document is available under NDA. For more information, please contact your local Atmel sales office.

Figure 1. Block Diagram

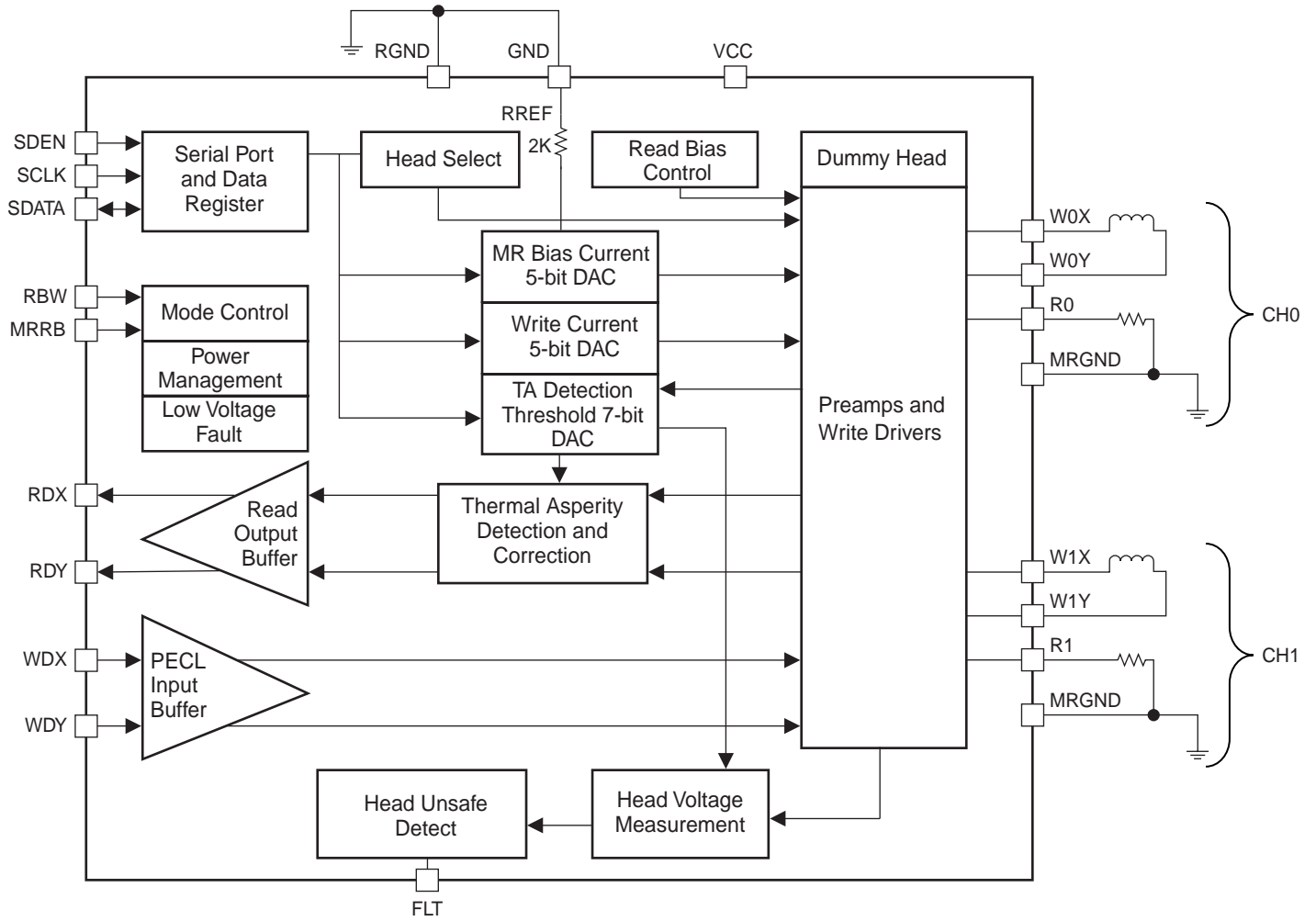



## Atmel Corporation

2325 Orchard Parkway  
San Jose, CA 95131, USA  
Tel: 1(408) 441-0311  
Fax: 1(408) 487-2600

## Regional Headquarters

### Europe

Atmel Sarl  
Route des Arsenaux 41  
Case Postale 80  
CH-1705 Fribourg  
Switzerland  
Tel: (41) 26-426-5555  
Fax: (41) 26-426-5500

### Asia

Room 1219  
Chinachem Golden Plaza  
77 Mody Road Tsimshatsui  
East Kowloon  
Hong Kong  
Tel: (852) 2721-9778  
Fax: (852) 2722-1369

### Japan

9F, Tonetsu Shinkawa Bldg.  
1-24-8 Shinkawa  
Chuo-ku, Tokyo 104-0033  
Japan  
Tel: (81) 3-3523-3551  
Fax: (81) 3-3523-7581

## Atmel Operations

### Memory

2325 Orchard Parkway  
San Jose, CA 95131, USA  
Tel: 1(408) 441-0311  
Fax: 1(408) 436-4314

### Microcontrollers

2325 Orchard Parkway  
San Jose, CA 95131, USA  
Tel: 1(408) 441-0311  
Fax: 1(408) 436-4314

La Chantrerie  
BP 70602  
44306 Nantes Cedex 3, France  
Tel: (33) 2-40-18-18-18  
Fax: (33) 2-40-18-19-60

### ASIC/ASSP/Smart Cards

Zone Industrielle  
13106 Rousset Cedex, France  
Tel: (33) 4-42-53-60-00  
Fax: (33) 4-42-53-60-01

1150 East Cheyenne Mtn. Blvd.  
Colorado Springs, CO 80906, USA  
Tel: 1(719) 576-3300  
Fax: 1(719) 540-1759

Scottish Enterprise Technology Park  
Maxwell Building  
East Kilbride G75 0QR, Scotland  
Tel: (44) 1355-803-000  
Fax: (44) 1355-242-743

### RF/Automotive

Theresienstrasse 2  
Postfach 3535  
74025 Heilbronn, Germany  
Tel: (49) 71-31-67-0  
Fax: (49) 71-31-67-2340

1150 East Cheyenne Mtn. Blvd.  
Colorado Springs, CO 80906, USA  
Tel: 1(719) 576-3300  
Fax: 1(719) 540-1759

### Biometrics/Imaging/Hi-Rel MPU/ High Speed Converters/RF Datacom

Avenue de Rochepleine  
BP 123  
38521 Saint-Egreve Cedex, France  
Tel: (33) 4-76-58-30-00  
Fax: (33) 4-76-58-34-80

---

### Literature Requests

[www.atmel.com/literature](http://www.atmel.com/literature)

**Disclaimer:** Atmel Corporation makes no warranty for the use of its products, other than those expressly contained in the Company's standard warranty which is detailed in Atmel's Terms and Conditions located on the Company's web site. The Company assumes no responsibility for any errors which may appear in this document, reserves the right to change devices or specifications detailed herein at any time without notice, and does not make any commitment to update the information contained herein. No licenses to patents or other intellectual property of Atmel are granted by the Company in connection with the sale of Atmel products, expressly or by implication. Atmel's products are not authorized for use as critical components in life support devices or systems.

© Atmel Corporation 2004. All rights reserved. Atmel® and combinations thereof, are the registered trademarks of Atmel Corporation or its subsidiaries. Other terms and product names may be the trademarks of others.



Printed on recycled paper.

3440AS-NETST-2/04