



Intel[®] 82801DB I/O Controller Hub 4 (ICH4)

Datasheet

May 2002

Information in this document is provided in connection with Intel® products. No license, express or implied, by estoppel or otherwise, to any intellectual property rights is granted by this document. Except as provided in Intel's Terms and Conditions of Sale for such products, Intel assumes no liability whatsoever, and Intel disclaims any express or implied warranty, relating to sale and/or use of Intel products including liability or warranties relating to fitness for a particular purpose, merchantability, or infringement of any patent, copyright or other intellectual property right. Intel products are not intended for use in medical, life saving, or life sustaining applications.

Intel may make changes to specifications and product descriptions at any time, without notice.

Designers must not rely on the absence or characteristics of any features or instructions marked "reserved" or "undefined." Intel reserves these for future definition and shall have no responsibility whatsoever for conflicts or incompatibilities arising from future changes to them.

The Intel® I/O Controller Hub 4 (ICH4) chipset component may contain design defects or errors known as errata which may cause the product to deviate from published specifications. Current characterized errata are available on request.

Contact your local Intel sales office or your distributor to obtain the latest specifications and before placing your product order.

I²C is a two-wire communications bus/protocol developed by Philips. SMBus is a subset of the I²C bus/protocol and was developed by Intel. Implementations of the I²C bus/protocol may require licenses from various entities, including Philips Electronics N.V. and North American Philips Corporation.

Alert on LAN is a result of the Intel-IBM Advanced Manageability Alliance and a trademark of IBM.

Copies of documents which have an ordering number and are referenced in this document, or other Intel literature may be obtained by calling 1-800-548-4725 or by visiting Intel's website at <http://www.intel.com>.

Intel, Intel SpeedStep, and the Intel logo are trademarks or registered trademarks of Intel Corporation or its subsidiaries in the United States and other countries.

*Other names and brands may be claimed as the property of others.

Copyright © 2002, Intel Corporation



Intel® 82801DB ICH4 Features

- PCI Bus Interface
 - Supports PCI Revision 2.2 Specification at 33 MHz
 - 133 MB/sec maximum throughput
 - Supports up to six master devices on PCI
 - One PCI REQ/GNT pair can be given higher arbitration priority (intended for external 1394 host controller)
 - Support for 44-bit addressing on PCI using DAC protocol
- Integrated LAN Controller
 - WfM 2.0 and IEEE 802.3 compliant
 - LAN Connect Interface (LCI)
 - 10/100 Mbit/sec ethernet support
- Integrated IDE Controller
 - Supports “Native Mode” register and interrupts
 - Independent timing of up to 4 drives, with separate primary and secondary IDE cable connections
 - Ultra ATA/100/66/33, BMIDE and PIO modes
 - Tri-state modes to enable swap bay
- USB
 - Includes three UHCI host controllers that support six external ports
 - New: Includes one EHCI high-speed USB 2.0 Host Controller that supports all six ports
 - New: Supports a USB 2.0 high-speed debug port
 - Supports wake-up from sleeping states S1–S5
 - Supports legacy keyboard/mouse software
- AC-Link for Audio and Telephony CODECs
 - Supports AC '97 2.3
 - New: Third AC_SDATA_IN line for three codec support
 - New: Independent bus master logic for seven channels (PCM In/Out, Mic 1 input, Mic 2 input, modem in/out, S/PDIF out)
 - Separate independent PCI functions for audio and modem
 - Support for up to six channels of PCM audio output (full AC3 decode)
 - Supports wake-up events
- Interrupt Controller
 - Support up to eight PCI interrupt pins
 - Supports PCI 2.2 message signaled interrupts
 - Two cascaded 82C59 with 15 interrupts
 - Integrated I/O APIC capability with 24 interrupts
 - Supports serial interrupt protocol
 - Supports processor system bus interrupt delivery
- New: 1.5 V operation with 3.3 V I/O
 - 5 V tolerant buffers on IDE, PCI, USB over-current and legacy signals
- Timers Based on 82C54
 - System timer, refresh request, speaker tone output
- Power Management Logic
 - ACPI 2.0 compliant
 - ACPI-defined power states (C1–C2, S3–S5)
 - Supports Desktop S1 state (like C2 state, only STPCLK# active)
 - ACPI power management timer
 - PCI PME# support
 - SMI# generation
 - All registers readable/restorable for proper resume from 0 V suspend states
- External Glue Integration
 - Integrated pull-up, pull-down and series termination resistors on IDE, processor interface
 - Integrated Pull-down and Series resistors on USB
- Enhanced Hub Interface Buffers Improve Routing flexibility (Not available with all Memory Controller Hubs)
- Firmware Hub (FWH) Interface Supports BIOS memory size up to 8 MB
- Low Pin Count (LPC) Interface
 - Supports two Master/DMA devices.
- Enhanced DMA Controller
 - Two cascaded 8237 DMA controllers
 - PCI DMA: Supports PC/PCI — Includes two PC/PCI REQ#/GNT# pairs
 - Supports LPC DMA
 - Supports DMA collection buffer to provide Type-F DMA performance for all DMA channels
- Real-Time Clock
 - 256-byte battery-backed CMOS RAM
- System TCO Reduction Circuits
 - Timers to generate SMI# and Reset upon detection of system hang
 - Timers to detect improper processor reset
 - Supports ability to disable external devices
- SMBus
 - New: Hardware packet error checking
 - New: Supports SMBus 2.0 Specification
 - Host interface allows processor to communicate via SMBus
 - Slave interface allows an external microcontroller to access system resources
 - Compatible with most 2-wire components that are also I²C compatible
- GPIO
 - TTL, open-drain, inversion
- Package 31x31 mm 421 BGA

The Intel® 82801DB ICH4 may contain design defects or errors known as errata which may cause the products to deviate from published specifications. Current characterized errata are available on request.

System Configuration

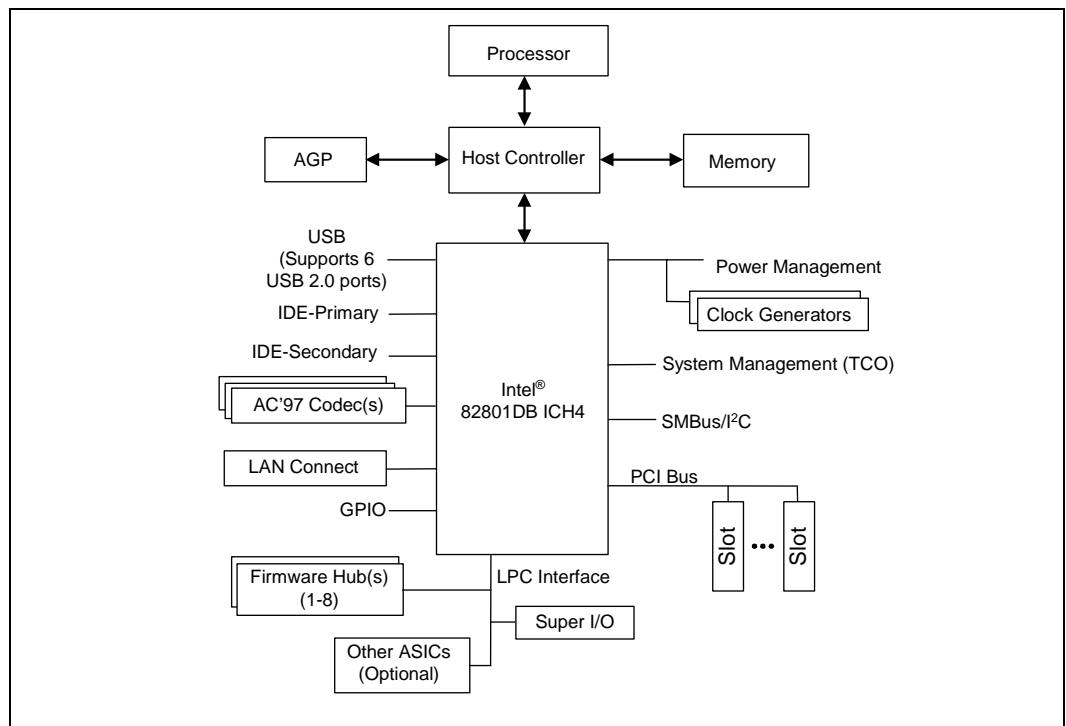

Contents

1	Introduction	27
	1.1 About This Datasheet	27
	1.2 Overview	30
2	Signal Description	37
	2.1 Hub Interface to Host Controller	39
	2.2 Link to LAN Connect.....	39
	2.3 EEPROM Interface	40
	2.4 Firmware Hub Interface	40
	2.5 PCI Interface	40
	2.6 IDE Interface	43
	2.7 LPC Interface.....	44
	2.8 Interrupt Interface.....	44
	2.9 USB Interface.....	45
	2.10 Power Management Interface.....	46
	2.11 Processor Interface.....	47
	2.12 SMBus Interface	48
	2.13 System Management Interface	48
	2.14 Real Time Clock Interface.....	49
	2.15 Other Clocks	49
	2.16 Miscellaneous Signals	49
	2.17 AC-Link	50
	2.18 General Purpose I/O	51
	2.19 Power and Ground.....	52
	2.20 Pin Straps	53
	2.20.1 Functional Straps.....	53
	2.20.2 External RTC Circuitry	54
	2.20.3 V5REF / Vcc3_3 Sequencing Requirements	54
	2.20.4 Test Signals	55
3	Intel® ICH4 Power Planes and Pin States	57
	3.1 Power Planes.....	57
	3.2 Integrated Pull-Ups and Pull-Downs	58
	3.3 IDE Integrated Series Termination Resistors.....	58
	3.4 Output and I/O Signals Planes and States	59
	3.5 Power Planes for Input Signals.....	63
4	Intel® ICH4 and System Clock Domains	65
5	Functional Description	67
	5.1 Hub Interface to PCI Bridge (D30:F0).....	67
	5.1.1 PCI Bus Interface	67
	5.1.2 PCI-to-PCI Bridge Model	68
	5.1.3 IDSEL to Device Number Mapping	68
	5.1.4 SERR# Functionality.....	68
	5.1.5 Parity Error Detection.....	70
	5.1.6 Standard PCI Bus Configuration Mechanism	71
	5.1.7 PCI Dual Address Cycle (DAC) Support.....	72

5.2	LAN Controller (B1:D8:F0).....	72
5.2.1	LAN Controller Architectural Overview	73
5.2.2	LAN Controller PCI Bus Interface	75
5.2.3	Serial EEPROM Interface	83
5.2.4	CSMA/CD Unit.....	84
5.2.5	Media Management Interface	85
5.2.6	TCO Functionality	85
5.3	LPC Bridge (w/ System and Management Functions) (D31:F0).....	86
5.3.1	LPC Interface	86
5.4	DMA Operation (D31:F0).....	92
5.4.1	Channel Priority	93
5.4.2	Address Compatibility Mode	93
5.4.3	Summary of DMA Transfer Sizes	94
5.4.4	Autoinitialize.....	94
5.4.5	Software Commands	95
5.5	PCI DMA.....	96
5.5.1	PCI DMA Expansion Protocol.....	96
5.5.2	PCI DMA Expansion Cycles	97
5.5.3	DMA Addresses.....	98
5.5.4	DMA Data Generation	98
5.5.5	DMA Byte Enable Generation.....	98
5.5.6	DMA Cycle Termination.....	99
5.5.7	LPC DMA.....	99
5.5.8	Asserting DMA Requests.....	99
5.5.9	Abandoning DMA Requests	100
5.5.10	General Flow of DMA Transfers	100
5.5.11	Terminal Count	101
5.5.12	Verify Mode.....	101
5.5.13	DMA Request Deassertion	101
5.5.14	SYNC Field / LDRQ# Rules.....	102
5.6	8254 Timers (D31:F0).....	103
5.6.1	Timer Programming	103
5.6.2	Reading from the Interval Timer	104
5.7	8259 Interrupt Controllers (PIC) (D31:F0)	106
5.7.1	Interrupt Handling	107
5.7.2	Initialization Command Words (ICWx).....	108
5.7.3	Operation Command Words (OCW).....	109
5.7.4	Modes of Operation	109
5.7.5	Masking Interrupts	112
5.7.6	Steering PCI Interrupts	112
5.8	Advanced Interrupt Controller (APIC) (D31:F0).....	113
5.8.1	Interrupt Handling	113
5.8.2	Interrupt Mapping.....	113
5.8.3	APIC Bus Functional Description.....	114
5.8.4	PCI Message-Based Interrupts.....	121
5.8.5	Processor System Bus Interrupt Delivery	122
5.9	Serial Interrupt (D31:F0).....	124
5.9.1	Start Frame	125
5.9.2	Data Frames	125
5.9.3	Stop Frame	125
5.9.4	Specific Interrupts Not Supported via SERIRQ.....	126



	5.9.5	Data Frame Format.....	126
5.10		Real Time Clock (D31:F0)	127
	5.10.1	Update Cycles.....	127
	5.10.2	Interrupts.....	128
	5.10.3	Lockable RAM Ranges	128
	5.10.4	Century Rollover	128
	5.10.5	Clearing Battery-Backed RTC RAM.....	128
5.11		Processor Interface (D31:F0).....	130
	5.11.1	Processor Interface Signals	130
	5.11.2	Dual-Processor Designs	132
	5.11.3	Speed Strapping for Processor.....	134
5.12		Power Management (D31:F0).....	135
	5.12.1	Intel® ICH4 and System Power States.....	135
	5.12.2	System Power Planes.....	137
	5.12.3	Intel® ICH4 Power Planes.....	137
	5.12.4	SMI#/SCI Generation.....	137
	5.12.5	Dynamic Processor Clock Control	139
	5.12.6	Sleep States.....	141
	5.12.7	Thermal Management.....	145
	5.12.8	Event Input Signals and Their Usage	146
	5.12.9	ALT Access Mode.....	148
	5.12.10	System Power Supplies, Planes, and Signals	151
	5.12.11	Clock Generators	152
	5.12.12	Legacy Power Management Theory of Operation	153
5.13		System Management (D31:F0).....	154
	5.13.1	Theory of Operation	154
	5.13.2	Alert on LAN*	155
5.14		General Purpose I/O	159
	5.14.1	GPIO Mapping	159
	5.14.2	Power Wells	161
	5.14.3	SMI# and SCI Routing	161
5.15		IDE Controller (D31:F1)	161
	5.15.1	PIO Transfers.....	162
	5.15.2	Bus Master Function	164
	5.15.3	Ultra ATA/33 Protocol	168
	5.15.4	Ultra ATA/66 Protocol	170
	5.15.5	Ultra ATA/100 Protocol	170
	5.15.6	Ultra ATA/33/66/100 Timing.....	171
	5.15.7	IDE Swap Bay.....	171
5.16		USB UHCI Controllers (D29:F0, F1 and F2).....	172
	5.16.1	Data Structures in Main Memory	172
	5.16.2	Data Transfers to/from Main Memory	178
	5.16.3	Data Encoding and Bit Stuffing.....	184
	5.16.4	Bus Protocol.....	184
	5.16.5	Packet Formats.....	187
	5.16.6	USB Interrupts	189
	5.16.7	USB Power Management	192
	5.16.8	USB Legacy Keyboard Operation	192
5.17		USB EHCI Controller (D29:F7)	195
	5.17.1	EHC Initialization.....	195
	5.17.2	Data Structures in Main Memory	196

5.17.3	USB 2.0 Enhanced Host Controller DMA	196
5.17.4	Data Encoding and Bit Stuffing	199
5.17.5	Packet Formats	199
5.17.6	USB EHCI Interrupts and Error Conditions	200
5.17.7	USB EHCI Power Management	201
5.17.8	Interaction with Classic Host Controllers	202
5.17.9	USB 2.0 Legacy Keyboard Operation	204
5.17.10	USB 2.0 EHCI Based Debug Port	205
5.18	SMBus Controller Functional Description (D31:F3)	210
5.18.1	Host Controller	210
5.18.2	Bus Arbitration	220
5.18.3	Bus Timing	220
5.18.4	Interrupts / SMI#	221
5.18.5	SMBALERT#	222
5.18.6	SMBus CRC Generation and Checking	222
5.18.7	SMBus Slave Interface	222
5.19	AC '97 Controller Functional Description (Audio D31:F5, Modem D31:F6)	227
5.19.1	PCI Power Management	229
5.19.2	AC-Link Overview	230
5.19.3	AC-Link Low Power Mode	238
5.19.4	AC '97 Cold Reset	239
5.19.5	AC '97 Warm Reset	239
5.19.6	System Reset	240
5.19.7	Hardware Assist to Determine AC_SDIN Used Per Codec	241
5.19.8	Software Mapping of AC_SDIN to DMA Engine	241
6	Register and Memory Mapping	243
6.1	PCI Devices and Functions	244
6.2	PCI Configuration Map	245
6.3	I/O Map	245
6.3.1	Fixed I/O Address Ranges	245
6.3.2	Variable I/O Decode Ranges	248
6.4	Memory Map	249
6.4.1	Boot-Block Update Scheme	250
7	LAN Controller Registers (B1:D8:F0)	251
7.1	PCI Configuration Registers (B1:D8:F0)	251
7.1.1	VID—Vendor ID Register (LAN Controller—B1:D8:F0)	252
7.1.2	DID—Device ID Register (LAN Controller—B1:D8:F0)	252
7.1.3	PCICMD—PCI Command Register (LAN Controller—B1:D8:F0) ..	253
7.1.4	PCISTS—PCI Status Register (LAN Controller—B1:D8:F0)	254
7.1.5	REVID—Revision ID Register (LAN Controller—B1:D8:F0)	255
7.1.6	SCC—Sub-Class Code Register (LAN Controller—B1:D8:F0)	255
7.1.7	BCC—Base-Class Code Register (LAN Controller—B1:D8:F0)	255
7.1.8	CLS—Cache Line Size Register (LAN Controller—B1:D8:F0)	255
7.1.9	PMLT—PCI Master Latency Timer Register (LAN Controller—B1:D8:F0)	256
7.1.10	HEADTYP—Header Type Register (LAN Controller—B1:D8:F0) ..	256
7.1.11	CSR_MEM_BASE CSR — Memory-Mapped Base Address Register (LAN Controller—B1:D8:F0)	256
7.1.12	CSR_IO_BASE — CSR I/O-Mapped Base Address Register (LAN Controller—B1:D8:F0)	257



7.1.13	SVID — Subsystem Vendor ID (LAN Controller—B1:D8:F0)	257
7.1.14	SID — Subsystem ID (LAN Controller—B1:D8:F0)	257
7.1.15	CAP_PTR — Capabilities Pointer (LAN Controller—B1:D8:F0)	258
7.1.16	INT_LN — Interrupt Line Register (LAN Controller—B1:D8:F0).....	258
7.1.17	INT_PN — Interrupt Pin Register (LAN Controller—B1:D8:F0).....	258
7.1.18	MIN_GNT — Minimum Grant Register (LAN Controller—B1:D8:F0)	258
7.1.19	MAX_LAT — Maximum Latency Register (LAN Controller—B1:D8:F0)	259
7.1.20	CAP_ID — Capability ID Register (LAN Controller—B1:D8:F0)	259
7.1.21	NXT_PTR — Next Item Pointer (LAN Controller—B1:D8:F0)	259
7.1.22	PM_CAP — Power Management Capabilities (LAN Controller—B1:D8:F0)	260
7.1.23	PMCSR — Power Management Control/Status Register (LAN Controller—B1:D8:F0)	260
7.1.24	PCIDATA — PCI Power Management Data Register (LAN Controller—B1:D8:F0)	261
7.2	LAN Control / Status Registers (CSR)	262
7.2.1	System Control Block Status Word Register	262
7.2.2	System Control Block Command Word Register	264
7.2.3	System Control Block General Pointer Register	266
7.2.4	PORT Register.....	266
7.2.5	EEPROM Control Register	267
7.2.6	Management Data Interface (MDI) Control Register	268
7.2.7	Receive DMA Byte Count Register	269
7.2.8	Early Receive Interrupt Register	269
7.2.9	Flow Control Register	270
7.2.10	Power Management Driver (PMDR) Register.....	271
7.2.11	General Control Register	272
7.2.12	General Status Register.....	272
7.2.13	Statistical Counters	273
8	Hub Interface to PCI Bridge Registers (D30:F0)	275
8.1	PCI Configuration Registers (D30:F0)	275
8.1.1	VID—Vendor ID Register (HUB-PCI—D30:F0)	276
8.1.2	DID—Device ID Register (HUB-PCI—D30:F0).....	276
8.1.3	CMD—Command Register (HUB-PCI—D30:F0).....	277
8.1.4	PD_STS—Primary Device Status Register (HUB-PCI—D30:F0)	278
8.1.5	RID—Revision Identification Register (HUB-PCI—D30:F0)	279
8.1.6	SCC—Sub-Class Code Register (HUB-PCI—D30:F0).....	279
8.1.7	BCC—Base-Class Code Register (HUB-PCI—D30:F0).....	279
8.1.8	PMLT—Primary Master Latency Timer Register (HUB-PCI—D30:F0)	279
8.1.9	HEADTYP—Header Type Register (HUB-PCI—D30:F0).....	280
8.1.10	PBUS_NUM—Primary Bus Number Register (HUB-PCI—D30:F0)	280
8.1.11	SBUS_NUM—Secondary Bus Number Register (HUB-PCI—D30:F0)	280
8.1.12	SUB_BUS_NUM—Subordinate Bus Number Register (HUB-PCI—D30:F0)	280

8.1.13	SMLT—Secondary Master Latency Timer Register (HUB-PCI—D30:F0)	281
8.1.14	IOBASE—I/O Base Register (HUB-PCI—D30:F0)	281
8.1.15	IOLIM—I/O Limit Register (HUB-PCI—D30:F0)	281
8.1.16	SECSTS—Secondary Status Register (HUB-PCI—D30:F0).....	282
8.1.17	MEMBASE—Memory Base Register (HUB-PCI—D30:F0)	283
8.1.18	MEMLIM—Memory Limit Register (HUB-PCI—D30:F0)	283
8.1.19	PREF_MEM_BASE—Prefetchable Memory Base Register (HUB-PCI—D30:F0)	283
8.1.20	PREF_MEM_MLT—Prefetchable Memory Limit Register (HUB-PCI—D30:F0)	284
8.1.21	IOBASE_HI—I/O Base Upper 16 Bits Register (HUB-PCI—D30:F0)	284
8.1.22	IOLIM_HI—I/O Limit Upper 16 Bits Register (HUB-PCI—D30:F0)	284
8.1.23	INT_LINE—Interrupt Line Register (HUB-PCI—D30:F0)	284
8.1.24	BRIDGE_CNT—Bridge Control Register (HUB-PCI—D30:F0)	285
8.1.25	HI1_CMD—Hub Interface 1 Command Control Register (HUB-PCI—D30:F0)	286
8.1.26	DEVICE_HIDE—Secondary PCI Device Hiding Register (HUB-PCI—D30:F0)	287
8.1.27	CNF—ICH4 Configuration Register (HUB-PCI—D30:F0)	288
8.1.28	MTT—Multi-Transaction Timer Register (HUB-PCI—D30:F0)	288
8.1.29	PCI_MAST_STS—PCI Master Status Register (HUB-PCI—D30:F0)	289
8.1.30	ERR_CMD—Error Command Register (HUB-PCI—D30:F0)	289
8.1.31	ERR_STS—Error Status Register (HUB-PCI—D30:F0).....	290

9

LPC Interface Bridge Registers (D31:F0)..... 291

9.1	PCI Configuration Registers (D31:F0)	291
9.1.1	VID—Vendor ID Register (LPC I/F—D31:F0).....	292
9.1.2	DID—Device ID Register (LPC I/F—D31:F0)	292
9.1.3	PCICMD—PCI COMMAND Register (LPC I/F—D31:F0).....	293
9.1.4	PCISTA—PCI Device Status (LPC I/F—D31:F0)	294
9.1.5	REVID—Revision ID Register (LPC I/F—D31:F0).....	294
9.1.6	PI—Programming Interface (LPC I/F—D31:F0)	295
9.1.7	SCC—Sub-Class Code Register (LPC I/F—D31:F0)	295
9.1.8	BCC—Base-Class Code Register (LPC I/F—D31:F0)	295
9.1.9	HEADTYP—Header Type Register (LPC I/F—D31:F0)	295
9.1.10	PMBASE—ACPI Base Address (LPC I/F—D31:F0).....	296
9.1.11	ACPI_CNTL—ACPI Control (LPC I/F — D31:F0).....	296
9.1.12	BIOS_CNTL—BIOS Control Register (LPC I/F—D31:F0).....	297
9.1.13	TCO_CNTL — TCO Control (LPC I/F — D31:F0)	297
9.1.14	GPIOBASE—GPIO Base Address (LPC I/F—D31:F0)	298
9.1.15	GPIO_CNTL—GPIO Control (LPC I/F—D31:F0)	298
9.1.16	PIRQ[n]_ROUT—PIRQ[A,B,C,D] Routing Control (LPC I/F—D31:F0).....	298
9.1.17	SERIRQ_CNTL—Serial IRQ Control (LPC I/F—D31:F0).....	299
9.1.18	PIRQ[n]_ROUT—PIRQ[E,F,G,H] Routing Control (LPC I/F—D31:F0).....	299
9.1.19	D31_ERR_CFG—Device 31 Error Configuration Register (LPC I/F—D31:F0).....	300



9.1.20	D31_ERR_STS—Device 31 Error Status Register (LPC I/F—D31:F0)	300
9.1.21	PCI_DMA_CFG—PCI DMA Configuration (LPC I/F—D31:F0)	301
9.1.22	GEN_CNTL — General Control Register (LPC I/F — D31:F0)	302
9.1.23	GEN_STA—General Status Register (LPC I/F—D31:F0)	304
9.1.24	BACK_CNTL—Backed Up Control Register (LPC I/F—D31:F0)	304
9.1.25	RTC_CONF—RTC Configuration Register (LPC I/F—D31:F0).....	305
9.1.26	COM_DEC—LPC I/F Communication Port Decode Ranges (LPC I/F—D31:F0)	305
9.1.27	FDD/LPT_DEC—LPC I/F FDD & LPT Decode Ranges (LPC I/F—D31:F0)	306
9.1.28	SND_DEC—LPC I/F Sound Decode Ranges (LPC I/F—D31:F0)	306
9.1.29	FWH_DEC_EN1—FWH Decode Enable 1 Register (LPC I/F—D31:F0)	307
9.1.30	GEN1_DEC—LPC I/F Generic Decode Range 1 Register (LPC I/F—D31:F0)	308
9.1.31	LPC_EN—LPC I/F Enables Register (LPC I/F—D31:F0).....	308
9.1.32	FWH_SEL1—FWH Select 1 Register (LPC I/F—D31:F0).....	310
9.1.33	GEN2_DEC—LPC I/F Generic Decode Range 2 Register (LPC I/F—D31:F0)	311
9.1.34	FWH_SEL2—FWH Select 2 Register (LPC I/F—D31:F0).....	311
9.1.35	FWH_DEC_EN2—FWH Decode Enable 2 Register (LPC I/F—D31:F0)	312
9.1.36	FUNC_DIS—Function Disable Register (LPC I/F—D31:F0)	313
9.2	DMA I/O Registers	315
9.2.1	DMABASE_CA—DMA Base and Current Address Registers	316
9.2.2	DMABASE_CC—DMA Base and Current Count Registers.....	316
9.2.3	DMAMEM_LP—DMA Memory Low Page Registers	317
9.2.4	DMACMD—DMA Command Register	317
9.2.5	DMASTA—DMA Status Register.....	318
9.2.6	DMA_WRSMSK—DMA Write Single Mask Register	318
9.2.7	DMACH_MODE—DMA Channel Mode Register.....	319
9.2.8	DMA Clear Byte Pointer Register	319
9.2.9	DMA Master Clear Register	320
9.2.10	DMA_CLMSK—DMA Clear Mask Register	320
9.2.11	DMA_WRMSK—DMA Write All Mask Register	320
9.3	Timer I/O Registers.....	321
9.3.1	TCW—Timer Control Word Register	321
9.3.2	SBYTE_FMT—Interval Timer Status Byte Format Register	323
9.3.3	Counter Access Ports Register.....	323
9.4	8259 Interrupt Controller (PIC) Registers	324
9.4.1	ICW1—Initialization Command Word 1 Register	325
9.4.2	ICW2—Initialization Command Word 2 Register	326
9.4.3	ICW3—Master Controller Initialization Command Word 3 Register.....	326
9.4.4	ICW3—Slave Controller Initialization Command Word 3 Register	327
9.4.5	ICW4—Initialization Command Word 4 Register	327
9.4.6	OCW1—Operational Control Word 1 (Interrupt Mask) Register	327
9.4.7	OCW2—Operational Control Word 2 Register	328
9.4.8	OCW3—Operational Control Word 3 Register	328
9.4.9	ELCR1—Master Controller Edge/Level Triggered Register	329

9.4.10	ELCR2—Slave Controller Edge/Level Triggered Register	330
9.5	Advanced Interrupt Controller (APIC)	331
9.5.1	APIC Register Map	331
9.5.2	IND—Index Register	332
9.5.3	DAT—Data Register	332
9.5.4	IRQPA—IRQ Pin Assertion Register	332
9.5.5	EOIR—EOI Register	333
9.5.6	ID—Identification Register	333
9.5.7	VER—Version Register	334
9.5.8	ARBID—Arbitration ID Register	334
9.5.9	BOOT_CONFIG—Boot Configuration Register	334
9.5.10	Redirection Table	335
9.6	Real Time Clock Registers	337
9.6.1	I/O Register Address Map	337
9.6.2	Indexed Registers	338
9.7	Processor Interface Registers	342
9.7.1	NMI_SC—NMI Status and Control Register	342
9.7.2	NMI_EN—NMI Enable (and Real Time Clock Index) Register	343
9.7.3	PORT92—Fast A20 and Init Register	343
9.7.4	COPROC_ERR—Coprocessor Error Register	343
9.7.5	RST_CNT—Reset Control Register	344
9.8	Power Management Registers (D31:F0)	345
9.8.1	Power Management PCI Configuration Registers (D31:F0)	345
9.8.2	APM I/O Decode	352
9.8.3	Power Management I/O Registers	353
9.9	System Management TCO Registers (D31:F0)	371
9.9.1	TCO1_RLD—TCO Timer Reload and Current Value Register	371
9.9.2	TCO1_TMR—TCO Timer Initial Value Register	372
9.9.3	TCO1_DAT_IN—TCO Data In Register	372
9.9.4	TCO1_DAT_OUT—TCO Data Out Register	372
9.9.5	TCO1_STS—TCO1 Status Register	373
9.9.6	TCO2_STS—TCO2 Status Register	374
9.9.7	TCO1_CNT—TCO1 Control Register	375
9.9.8	TCO2_CNT—TCO2 Control Register	376
9.9.9	TCO_MESSAGE1 and TCO_MESSAGE2 Registers	376
9.9.10	TCO_WDSTATUS—TCO2 Control Register	377
9.9.11	SW_IRQ_GEN—Software IRQ Generation Register	377
9.10	General Purpose I/O Registers (D31:F0)	378
9.10.1	GPIO_USE_SEL—GPIO Use Select Register	378
9.10.2	GP_IO_SEL—GPIO Input/Output Select Register	379
9.10.3	GP_LVL—GPIO Level for Input or Output Register	379
9.10.4	GPO_BLINK—GPO Blink Enable Register	380
9.10.5	GPI_INV—GPIO Signal Invert Register	381
9.10.6	GPIO_USE_SEL2—GPIO Use Select 2 Register	381
9.10.7	GP_IO_SEL2—GPIO Input/Output Select 2 Register	382
9.10.8	GP_LVL2—GPIO Level for Input or Output 2 Register	382
10	IDE Controller Registers (D31:F1)	383
10.1	PCI Configuration Registers (IDE—D31:F1)	383
10.1.1	VID—Vendor ID Register (LPC I/F—D31:F1)	384
10.1.2	DID—Device ID Register (LPC I/F—D31:F1)	384
10.1.3	CMD — Command Register (IDE—D31:F1)	384



10.1.4	STS — Device Status Register (IDE—D31:F1)	385
10.1.5	REVID—Revision ID Register (IDE—D31:F1)	385
10.1.6	PI — Programming Interface Register (IDE—D31:F1)	386
10.1.7	SCC — Sub Class Code Register (IDE—D31:F1)	386
10.1.8	BCC — Base Class Code Register (IDE—D31:F1)	386
10.1.9	MLT — Master Latency Timer Register (IDE—D31:F1)	387
10.1.10	PCMD_BAR—Primary Command Block Base Address Register (IDE—D31:F1)	387
10.1.11	PCNL_BAR—Primary Control Block Base Address Register (IDE—D31:F1)	387
10.1.12	SCMD_BAR—Secondary Command Block Base Address Register (IDE D31:F1)	388
10.1.13	SCNL_BAR—Secondary Control Block Base Address Register (IDE D31:F1)	388
10.1.14	BM_BASE — Bus Master Base Address Register (IDE—D31:F1)	388
10.1.15	EXBAR — Expansion Base Address Register (IDE—D31:F1)	389
10.1.16	IDE_SVID — Subsystem Vendor ID Register (IDE—D31:F1)	389
10.1.17	IDE_SID — Subsystem ID Register (IDE—D31:F1)	389
10.1.18	INTR_LN—Interrupt Line Register (IDE—D31:F1)	390
10.1.19	INTR_PN—Interrupt Pin Register (IDE—D31:F1)	390
10.1.20	IDE_TIM — IDE Timing Register (IDE—D31:F1)	390
10.1.21	SLV_IDETIM—Slave (Drive 1) IDE Timing Register (IDE—D31:F1)	392
10.1.22	SDMA_CNT—Synchronous DMA Control Register (IDE—D31:F1)	393
10.1.23	SDMA_TIM—Synchronous DMA Timing Register (IDE—D31:F1)	394
10.1.24	IDE_CONFIG—IDE I/O Configuration Register (IDE—D31:F1)	395
10.2	Bus Master IDE I/O Registers (D31:F1)	396
10.2.1	BMIC[P,S]—Bus Master IDE Command Register	397
10.2.2	BMIS[P,S]—Bus Master IDE Status Register	398
10.2.3	BMID[P,S]—Bus Master IDE Descriptor Table Pointer Register	398
11	USB UHCI Controllers Registers	399
11.1	PCI Configuration Registers (D29:F0/F1/F2)	399
11.1.1	VID—Vendor Identification Register (USB—D29:F0/F1/F2)	399
11.1.2	DID—Device Identification Register (USB—D29:F0/F1/F2)	400
11.1.3	CMD—Command Register (USB—D29:F0/F1/F2)	400
11.1.4	STA—Device Status Register (USB—D29:F0/F1/F2)	401
11.1.5	RID—Revision Identification Register (USB—D29:F0/F1/F2)	401
11.1.6	PI—Programming Interface (USB—D29:F0/F1/F2)	401
11.1.7	SCC—Sub Class Code Register (USB—D29:F0/F1/F2)	402
11.1.8	BCC—Base Class Code Register (USB—D29:F0/F1/F2)	402
11.1.9	HTYPE—Header Type Register (USB—D29:F0/F1/F2)	402
11.1.10	BASE—Base Address Register (USB—D29:F0/F1/F2)	403
11.1.11	SVID — Subsystem Vendor ID (USB—D29:F0/F1/F2)	403
11.1.12	SID — Subsystem ID (USB—D29:F0/F1/F2)	403
11.1.13	INTR_LN—Interrupt Line Register (USB—D29:F0/F1/F2)	404
11.1.14	INTR_PN—Interrupt Pin Register (USB—D29:F0/F1/F2)	404
11.1.15	USB_RELNUM—USB Release Number Register	404

	(USB—D29:F0/F1/F2)	404
11.1.16	USB_LEGKEY—USB Legacy Keyboard/Mouse Control Register (USB—D29:F0/F1/F2)	405
11.1.17	USB_RES—USB Resume Enable Register (USB—D29:F0/F1/F2)	406
11.2	USB I/O Registers	407
11.2.1	USBCMD—USB Command Register	408
11.2.2	USBSTS—USB Status Register	411
11.2.3	USBINTR—Interrupt Enable Register	412
11.2.4	FRNUM—Frame Number Register	412
11.2.5	FRBASEADD—Frame List Base Address	413
11.2.6	SOFMOD—Start of Frame Modify Register	414
11.2.7	PORTSC[0,1]—Port Status and Control Register	415
12	EHCI Controller Registers (D29:F7)	417
12.1	USB EHCI Configuration Registers (D29:F7)	417
12.1.1	VID—Vendor ID Register (USB EHCI—D29:F7)	418
12.1.2	DID—Device ID Register (USB EHCI—D29:F7)	418
12.1.3	PCICMD—PCI Command Register (USB EHCI—D29:F7)	419
12.1.4	PCISTS—PCI Device Status Register (USB EHCI—D29:F7)	420
12.1.5	REVID—Revision ID Register (USB EHCI—D29:F7)	420
12.1.6	PI—Programming Interface Register (USB EHCI—D29:F7)	421
12.1.7	SCC—Sub Class Code Register (USB EHCI—D29:F7)	421
12.1.8	BCC—Base Class Code Register (USB EHCI—D29:F7)	421
12.1.9	MLT—PCI Master Latency Timer Register (USB EHCI—D29:F7)	421
12.1.10	MEM_BASE—Memory Base Address Register (USB EHCI—D29:F7)	422
12.1.11	SVID—USB EHCI Subsystem Vendor ID Register (USB EHCI—D29:F7)	422
12.1.12	SID—USB EHCI Subsystem ID Register (USB EHCI—D29:F7)	422
12.1.13	CAP_PTR—Capabilities Pointer Register (USB EHCI—D29:F7)	423
12.1.14	INT_LN—Interrupt Line Register (USB EHCI—D29:F7)	423
12.1.15	INT_PN—Interrupt Pin Register (USB EHCI—D29:F7)	423
12.1.16	PWR_CAPID—PCI Power Management Capability ID Register (USB EHCI—D29:F7)	423
12.1.17	NXT_PTR1—Next Item Pointer #1 Register (USB EHCI—D29:F7)	424
12.1.18	PWR_CAP—Power Management Capabilities Register (USB EHCI—D29:F7)	424
12.1.19	PWR_CNTL_STS—Power Management Control/Status Register (USB EHCI—D29:F7)	425
12.1.20	DEBUG_CAPID—Debug Port Capability ID Register (USB EHCI—D29:F7)	425
12.1.21	NXT_PTR2—Next Item Pointer #2 Register (USB EHCI—D29:F7)	426
12.1.22	DEBUG_BASE—Debug Port Base Offset Register (USB EHCI—D29:F7)	426
12.1.23	USB_RELNUM—USB Release Number Register (USB EHCI—D29:F7)	426
12.1.24	FL_ADJ—Frame Length Adjustment Register (USB EHCI—D29:F7)	427
12.1.25	PWAKE_CAP—Port Wake Capability Register (USB EHCI—D29:F7)	427



12.1.26	LEG_EXT_CAP—USB EHCI Legacy Support Extended Capability Register (USB EHCI—D29:F7).....	428
12.1.27	LEG_EXT_CS—USB EHCI Legacy Support Extended Control / Status Register (USB EHCI—D29:F7).....	428
12.1.28	SPECIAL_SMI—Intel Specific USB EHCI SMI Register (USB EHCI—D29:F7).....	430
12.1.29	ACCESS_CNTL—Access Control Register (USB EHCI—D29:F7).....	431
12.1.30	HS_Ref_V—USB HS Reference Voltage Register (USB EHCI—D29:F7).....	431
12.2	Memory-Mapped I/O Registers.....	432
12.2.1	Host Controller Capability Registers.....	432
12.2.2	Host Controller Operational Registers.....	435
12.2.3	USB 2.0-Based Debug Port Register.....	447
13	SMBus Controller Registers (D31:F3).....	451
13.1	PCI Configuration Registers (SMBUS—D31:F3).....	451
13.1.1	VID—Vendor Identification Register (SMBUS—D31:F3).....	451
13.1.2	DID—Device Identification Register (SMBUS—D31:F3).....	451
13.1.3	CMD—Command Register (SMBUS—D31:F3).....	452
13.1.4	STA—Device Status Register (SMBUS—D31:F3).....	452
13.1.5	REVID—Revision ID Register (SMBUS—D31:F3).....	453
13.1.6	SCC—Sub Class Code Register (SMBUS—D31:F3).....	453
13.1.7	BCC—Base Class Code Register (SMBUS—D31:F3).....	453
13.1.8	SMB_BASE—SMBUS Base Address Register (SMBUS—D31:F3).....	453
13.1.9	SVID — Subsystem Vendor ID (SMBUS—D31:F2/F4).....	454
13.1.10	SID — Subsystem ID (SMBUS—D31:F2/F4).....	454
13.1.11	INTR_LN—Interrupt Line Register (SMBUS—D31:F3).....	454
13.1.12	INTR_PN—Interrupt Pin Register (SMBUS—D31:F3).....	454
13.1.13	HOSTC—Host Configuration Register (SMBUS—D31:F3).....	455
13.2	SMBUS I/O Registers.....	456
13.2.1	HST_STS—Host Status Register.....	456
13.2.2	HST_CNT—Host Control Register.....	458
13.2.3	HST_CMD—Host Command Register.....	459
13.2.4	XMIT_SLVA—Transmit Slave Address Register.....	459
13.2.5	HST_D0—Data 0 Register.....	459
13.2.6	HST_D1—Data 1 Register.....	460
13.2.7	Host_BLOCK_DB—Host Block Data Byte Register.....	460
13.2.8	PEC—Packet Error Check (PEC) Register.....	460
13.2.9	RCV_SLVA—Receive Slave Address Register.....	461
13.2.10	SLV_DATA—Receive Slave Data Register.....	461
13.2.11	AUX_STS—Auxiliary Status Register.....	461
13.2.12	AUX_CTL—Auxiliary Control Register.....	462
13.2.13	SMLINK_PIN_CTL—SMLink Pin Control Register.....	462
13.2.14	SMBUS_PIN_CTL—SMBUS Pin Control Register.....	463
13.2.15	SLV_STS—Slave Status Register.....	463
13.2.16	SLV_CMD—Slave Command Register.....	464
13.2.17	NOTIFY_DADDR—Notify Device Address.....	464
13.2.18	NOTIFY_DLOW—Notify Data Low Byte Register.....	465
13.2.19	NOTIFY_DHIGH—Notify Data High Byte Register.....	465

14	AC '97 Audio Controller Registers (D31:F5)	467
14.1	AC '97 Audio PCI Configuration Space (D31:F5).....	467
14.1.1	VID—Vendor Identification Register (Audio—D31:F5).....	468
14.1.2	DID—Device Identification Register (Audio—D31:F5).....	468
14.1.3	PCICMD—PCI Command Register (Audio—D31:F5).....	469
14.1.4	PCISTS—PCI Device Status Register (Audio—D31:F5).....	470
14.1.5	RID—Revision Identification Register (Audio—D31:F5).....	471
14.1.6	PI—Programming Interface Register (Audio—D31:F5).....	471
14.1.7	SCC—Sub Class Code Register (Audio—D31:F5).....	471
14.1.8	BCC—Base Class Code Register (Audio—D31:F5).....	471
14.1.9	HEDT—Header Type Register (Audio—D31:F5).....	472
14.1.10	NAMBAR—Native Audio Mixer Base Address Register (Audio—D31:F5).....	472
14.1.11	NABMBAR—Native Audio Bus Mastering Base Address Register (Audio—D31:F5).....	473
14.1.12	MMBAR—Mixer Base Address Register (Audio—D31:F5).....	473
14.1.13	MBBAR—Bus Master Base Address Register (Audio—D31:F5).....	474
14.1.14	SVID—Subsystem Vendor ID Register (Audio—D31:F5).....	474
14.1.15	SID—Subsystem ID Register (Audio—D31:F5).....	475
14.1.16	CAP_PTR—Capabilities Pointer Register (Audio—D31:F5).....	475
14.1.17	INTR_LN—Interrupt Line Register (Audio—D31:F5).....	475
14.1.18	INTR_PN—Interrupt Pin Register (Audio—D31:F5).....	476
14.1.19	PCID—Programmable Codec ID Register (Audio—D31:F5).....	476
14.1.20	CFG—Configuration Register (Audio—D31:F5).....	477
14.1.21	PID—PCI Power Management Capability ID Register (Audio—D31:F5).....	477
14.1.22	PC—Power Management Capabilities Register (Audio—D31:F5).....	477
14.1.23	PCS—Power Management Control and Status Register (Audio—D31:F5).....	478
14.2	AC '97 Audio I/O Space (D31:F5).....	479
14.2.1	x_BDBAR—Buffer Descriptor Base Address Register.....	482
14.2.2	x_CIV—Current Index Value Register.....	483
14.2.3	x_LVI—Last Valid Index Register.....	483
14.2.4	x_SR—Status Register.....	484
14.2.5	x_PICB—Position In Current Buffer Register.....	485
14.2.6	x_PIV—Prefetched Index Value Register.....	485
14.2.7	x_CR—Control Register.....	486
14.2.8	GLOB_CNT—Global Control Register.....	487
14.2.9	GLOB_STA—Global Status Register.....	488
14.2.10	CAS—Codec Access Semaphore Register.....	490
14.2.11	SDM—SDATA_IN Map Register.....	491
15	AC '97 Modem Controller Registers (D31:F6)	493
15.1	AC '97 Modem PCI Configuration Space (D31:F6).....	493
15.1.1	VID—Vendor Identification Register (Modem—D31:F6).....	494
15.1.2	DID—Device Identification Register (Modem—D31:F6).....	494
15.1.3	PCICMD—PCI Command Register (Modem—D31:F6).....	494
15.1.4	PCISTA—Device Status Register (Modem—D31:F6).....	495
15.1.5	RID—Revision Identification Register (Modem—D31:F6).....	495
15.1.6	PI—Programming Interface Register (Modem—D31:F6).....	495



15.1.7	SCC—Sub Class Code Register (Modem—D31:F6).....	496
15.1.8	BCC—Base Class Code Register (Modem—D31:F6).....	496
15.1.9	HEDT—Header Type Register (Modem—D31:F6).....	496
15.1.10	MMBAR—Modem Mixer Base Address Register (Modem—D31:F6)	497
15.1.11	MBAR—Modem Base Address Register (Modem—D31:F6)	497
15.1.12	SVID—Subsystem Vendor ID (Modem—D31:F6)	498
15.1.13	SID—Subsystem ID (Modem—D31:F6)	498
15.1.14	CAP_PTR—Capabilities Pointer (Modem—D31:F6)	498
15.1.15	INTR_LN—Interrupt Line Register (Modem—D31:F6)	499
15.1.16	INT_PIN—Interrupt Pin (Modem—D31:F6)	499
15.1.17	PID—PCI Power Management Capability ID Register (Modem—D31:F6)	499
15.1.18	PC—Power Management Capabilities Register (Modem—D31:F6)	500
15.1.19	PCS—Power Management Control and Status Register (Modem—D31:F6)	500
15.2	AC '97 Modem I/O Space (D31:F6)	501
15.2.1	x_BDBAR—Buffer Descriptor List Base Address Register	503
15.2.2	x_CIV—Current Index Value Register	503
15.2.3	x_LVI—Last Valid Index Register	503
15.2.4	x_SR—Status Register	504
15.2.5	x_PICB—Position in Current Buffer Register.....	505
15.2.6	x_PIV—Prefetch Index Value Register	505
15.2.7	x_CR—Control Register	506
15.2.8	GLOB_CNT—Global Control Register.....	507
15.2.9	GLOB_STA—Global Status Register	508
15.2.10	CAS—Codec Access Semaphore Register	510
16	Ballout Definition	511
17	Electrical Characteristics	519
17.1	Absolute Maximum Ratings	519
17.2	Functional Operating Range	519
17.3	DC Characteristics	520
17.4	AC Characteristics	526
17.5	Timing Diagrams.....	539
18	Package Information	549
19	Testability	551
19.1	Test Mode Description	551
19.2	Tri-State Mode	552
19.3	XOR Chain Mode.....	552
19.3.1	XOR Chain Testability Algorithm Example	552
A	Register Index	561
B	Register Bit Index	580

Figures

n	System Configuration	4
2-1	Intel® ICH4 Interface Signals Block Diagram.....	38
2-2	Example External RTC Circuit	54
2-3	Example V5REF Sequencing Circuit	55
4-1	Conceptual System Clock Diagram	66
5-1	Primary Device Status Register Error Reporting Logic.....	69
5-2	Secondary Status Register Error Reporting Logic.....	69
5-3	NMI# Generation Logic.....	70
5-4	Integrated LAN Controller Block Diagram.....	73
5-5	64-Word EEPROM Read Instruction Waveform.....	83
5-6	LPC Interface Diagram	86
5-7	Typical Timing for LFRAME#.....	90
5-8	Abort Mechanism.....	90
5-9	Intel® ICH4 DMA Controller	92
5-10	DMA Serial Channel Passing Protocol	96
5-11	DMA Request Assertion Through LDRQ#.....	99
5-12	Coprocessor Error Timing Diagram	131
5-13	Signal Strapping	134
5-14	Physical Region Descriptor Table Entry	165
5-15	Transfer Descriptor	173
5-16	Example Queue Conditions	181
5-17	USB Data Encoding.....	184
5-18	USB Legacy Keyboard Enable and Status Paths.....	193
5-19	Intel® ICH4 USB Port Connections.....	202
5-20	Intel® ICH4 Based Audio Codec '97 Specification, Revision 2.3.....	229
5-21	AC '97 2.3 Controller-Codec Connection.....	230
5-22	AC-Link Protocol.....	231
5-23	AC-Link Powerdown Timing	238
5-24	SDIN Wake Signaling	239
16-1	Intel® ICH4 Ballout (Topview—Left Side)	512
16-2	Intel® ICH4 Ballout (Topview—Right Side).....	513
17-1	Clock Timing	539
17-2	Valid Delay from Rising Clock Edge	539
17-3	Setup and Hold Times	539
17-4	Float Delay.....	540
17-5	Pulse Width.....	540
17-6	Output Enable Delay.....	540
17-7	IDE PIO Mode.....	541
17-8	IDE Multiword DMA	541
17-9	Ultra ATA Mode (Drive Initiating a Burst Read)	542
17-10	Ultra ATA Mode (Sustained Burst)	542
17-11	Ultra ATA Mode (Pausing a DMA Burst)	543
17-12	Ultra ATA Mode (Terminating a DMA Burst)	543
17-13	USB Rise and Fall Times.....	543
17-14	USB Jitter.....	544
17-15	USB EOP Width.....	544
17-16	SMBus Transaction	544
17-17	SMBus Timeout	545
17-18	Power Sequencing and Reset Signal Timings.....	545



17-19	G3 (Mechanical Off) to S0 Timings.....	546
17-20	S0 to S1 to S0 Timing.....	546
17-21	S0 to S5 to S0 Timings	547
17-22	C0 to C2 to C0 Timings.....	547
17-23	AC '97 Data Input and Output Timings	548
18-1	Intel® ICH4 Package (Top and Side Views)	549
18-2	Intel® ICH4 Package (Bottom View)	550
19-1	Test Mode Entry (XOR Chain Example)	551
19-2	Example XOR Chain Circuitry.....	552

Tables

1-1	Industry Specifications	27
1-2	PCI Devices and Functions	30
2-1	Hub Interface Signals	39
2-2	LAN Connect Interface Signals.....	39
2-3	EEPROM Interface Signals	40
2-4	Firmware Hub Interface Signals	40
2-5	PCI Interface Signals	40
2-6	IDE Interface Signals	43
2-7	LPC Interface Signals	44
2-8	Interrupt Signals.....	44
2-9	USB Interface Signals.....	45
2-10	Power Management Interface Signals.....	46
2-11	Processor Interface Signals.....	47
2-12	SM Bus Interface Signals	48
2-13	System Management Interface Signals	48
2-14	Real Time Clock Interface	49
2-15	Other Clocks	49
2-16	Miscellaneous Signals	49
2-17	AC-Link Signals	50
2-18	General Purpose I/O Signals	51
2-19	Power and Ground Signals.....	52
2-20	Functional Strap Definitions.....	53
2-21	Test Mode Selection	55
3-1	Intel® ICH4 System Power Planes.....	57
3-2	Integrated Pull-Up and Pull-Down Resistors	58
3-3	IDE Series Termination Resistors.....	58
3-4	Power Plane and States for Output and I/O Signal	59
3-5	Power Plane for Input Signals	63
4-1	Intel® ICH4 and System Clock Domains.....	65
5-1	Type 0 Configuration Cycle Device Number Translation.....	71
5-2	LPC Cycle Types Supported	87
5-3	Start Field Bit Definitions	87
5-4	Cycle Type Bit Definitions.....	88
5-5	Transfer Size Bit Definition	88
5-6	SYNC Bit Definition.....	88
5-7	Intel® ICH4 Response to Sync Failures.....	89
5-8	DMA Transfer Size	94
5-9	Address Shifting in 16-bit I/O DMA Transfers.....	94
5-10	DMA Cycle vs. I/O Address	98
5-11	PCI Data Bus vs. DMA I/O Port Size	98
5-12	DMA I/O Cycle Width vs. BE[3:0]#	98
5-13	Counter Operating Modes	104
5-14	Interrupt Controller Core Connections	106
5-15	Interrupt Status Registers	107
5-16	Content of Interrupt Vector Byte	107
5-17	APIC Interrupt Mapping	113
5-18	Arbitration Cycles.....	115
5-19	APIC Message Formats.....	115
5-20	EOI Message	116



5-21	Short Message.....	117
5-22	APIC Bus Status Cycle Definition	118
5-23	Lowest Priority Message (Without Focus Processor)	119
5-24	Remote Read Message	120
5-25	Interrupt Message Address Format	123
5-26	Interrupt Message Data Format	124
5-27	Stop Frame Explanation	125
5-28	Data Frame Format.....	126
5-29	Configuration Bits Reset By RTCRST# Assertion	129
5-30	INIT# Going Active	131
5-31	NMI Sources	132
5-32	DP Signal Differences.....	132
5-33	Frequency Strap Behavior Based on Exit State.....	134
5-34	Frequency Strap Bit Mapping	134
5-35	General Power States for Systems Using Intel® ICH4	135
5-36	State Transition Rules for Intel® ICH4	136
5-37	System Power Plane.....	137
5-38	Causes of SMI# and SCI	138
5-39	Break Events.....	139
5-40	Sleep Types	142
5-41	Causes of Wake Events.....	143
5-42	GPI Wake Events.....	143
5-43	Transitions Due to Power Failure.....	144
5-44	Transitions Due to Power Button	146
5-45	Transitions Due to RI# Signal	147
5-46	Write Only Registers with Read Paths in ALT Access Mode.....	149
5-47	PIC Reserved Bits Return Values.....	150
5-48	Register Write Accesses in ALT Access Mode.....	151
5-49	Intel® ICH4 Clock Inputs	152
5-50	Alert on LAN* Message Data	158
5-51	GPIO Implementation	159
5-52	IDE Legacy I/O Ports: Command Block Registers (CS1x# Chip Select)	163
5-53	IDE Transaction Timings (PCI Clocks)	164
5-54	Interrupt/Active Bit Interaction Definition.....	168
5-55	UltraATA/33 Control Signal Redefinitions	169
5-56	Frame List Pointer Bit Description	172
5-57	TD Link Pointer	173
5-58	TD Control and Status	174
5-59	TD Token	176
5-60	TD Buffer Pointer	176
5-61	Queue Head Block.....	177
5-62	Queue Head Link Pointer.....	177
5-63	Queue Element Link Pointer	177
5-64	Command Register, Status Register, and TD Status Bit Interaction	180
5-65	Queue Advance Criteria.....	182
5-66	USB Schedule List Traversal Decision Table	183
5-67	PID Format.....	185
5-68	PID Types	185
5-69	Address Field.....	186
5-70	Endpoint Field.....	186
5-71	Token Format.....	187

5-72	SOF Packet	188
5-73	Data Packet Format	188
5-74	Bits Maintained in Low Power States	192
5-75	USB Legacy Keyboard State Transitions	194
5-76	UHCI vs. EHCI	195
5-77	Debug Port Behavior	206
5-78	Quick Protocol	211
5-79	Send / Receive Byte Protocol without PEC	211
5-80	Send/Receive Byte Protocol with PEC	212
5-81	Write Byte/Word Protocol without PEC	212
5-82	Write Byte/Word Protocol with PEC	213
5-83	Read Byte/Word Protocol without PEC	214
5-84	Read Byte/Word Protocol with PEC	214
5-85	Process Call Protocol without PEC	215
5-86	Process Call Protocol with PEC	216
5-87	Block Read/Write Protocol without PEC	217
5-88	Block Read/Write Protocol with PEC	218
5-89	I ² C Block Read	219
5-90	Enable for SMBALERT#	221
5-91	Enables for SMBus Slave Write and SMBus Host Events	221
5-92	Enables for the Host Notify Command	221
5-93	Slave Write Cycle Format	223
5-94	Slave Write Registers	223
5-95	Command Types	224
5-96	Read Cycle Format	225
5-97	Data Values for Slave Read Registers	225
5-98	Host Notify Format	227
5-99	Features Supported by Intel [®] ICH4	228
5-100	AC '97 Signals	231
5-101	Input Slot 1 Bit Definitions	235
5-102	Output Tag Slot 0	237
5-103	AC-link State during PCIRST#	240
6-1	PCI Devices and Functions	244
6-2	Fixed I/O Ranges Decoded by Intel [®] ICH4	246
6-3	Variable I/O Decode Ranges	248
6-4	Memory Decode Ranges from Processor Perspective	249
7-1	LAN Controller PCI Configuration Register Address Map (LAN Controller—B1:D8:F0)	251
7-2	Configuration of Subsystem ID and Subsystem Vendor ID via EEPROM	257
7-3	Data Register Structure	261
7-4	Intel [®] ICH4 Integrated LAN Controller CSR Space	262
7-5	Self-Test Results Format	267
7-6	Statistical Counters	273
8-1	Hub Interface PCI Configuration Register Address Map (HUB-PCI—D30:F0)	275
9-1	LPC I/F PCI Configuration Register Address Map (LPC I/F—D31:F0)	291
9-2	DMA Registers	315
9-3	Interrupt Controller I/O Address Map (PIC Registers)	324
9-4	APIC Direct Registers	331
9-5	APIC Indirect Registers	331
9-6	RTC I/O Registers	337
9-7	RTC (Standard) RAM Bank	338



9-8	PCI Configuration Map (PM—D31:F0)	345
9-9	APM Register Map	352
9-10	ACPI and Legacy I/O Register Map	353
9-11	TCO I/O Register Map	371
9-12	Registers to Control GPIO	378
10-1	PCI Configuration Register Address Map (IDE—D31:F1)	383
10-2	Bus Master IDE I/O Registers	396
11-1	PCI Configuration Register Address Map (USB—D29:F0/F1/F2)	399
11-2	USB I/O Registers	407
11-3	Run/Stop, Debug Bit Interaction SWDBG (Bit 5), Run/Stop (Bit 0) Operation	409
12-1	USB EHCI PCI Configuration Register Address Map (D29:F7)	417
12-2	Enhanced Host Controller Capability Registers	432
12-3	Enhanced Host Controller Operational Registers	435
12-4	Debug Port Register Address Map	447
13-1	SMBus Controller PCI Configuration Register Address Map (SMBUS—D31:F3)	451
13-2	SMB I/O Registers	456
14-1	AC '97 Audio PCI Configuration Register Address Map (Audio—D31:F5)	467
14-2	Intel® ICH4 Audio Mixer Register Configuration	479
14-3	Native Audio Bus Master Control Registers	481
15-1	AC '97 Modem Controller PCI Configuration Register Address Map (Modem—D31:F6)	493
15-2	Intel® ICH4 Modem Mixer Register Configuration	501
15-3	Modem Registers	502
16-1	Intel® ICH4 Ball List	514
17-1	DC Current Characteristics	520
17-2	DC Characteristic Input Signal Association	520
17-3	DC Input Characteristics	521
17-4	DC Characteristic Output Signal Association	523
17-5	DC Output Characteristics	524
17-6	Other DC Characteristics	525
17-7	AC Input Characteristics	526
17-8	Clock Timings	526
17-9	PCI Interface Timing	528
17-10	IDE PIO and Multiword DMA Mode Timing	529
17-11	Ultra ATA Timing (Mode 0, Mode 1, Mode 2)	530
17-12	Ultra ATA Timing (Mode 3, Mode 4, Mode 5)	532
17-13	Universal Serial Bus Timing	534
17-14	IOAPIC Bus Timing	535
17-15	SMBus Timing	535
17-16	AC '97 Timing	535
17-18	Miscellaneous Timings	536
17-17	LPC Timing	536
17-19	Power Sequencing and Reset Signal Timings	537
17-20	Power Management Timings	538
19-1	Test Mode Selection	551
19-2	XOR Test Pattern Example	552
19-3	XOR Chain 1	553
19-4	XOR Chain 2	554
19-5	XOR Chain 3	555
19-6	XOR Chain 4-1	556

19-7	XOR Chain 4-2	557
19-8	XOR Chain 6.....	557
19-9	LONG XOR Chain	558
A-1	Intel® ICH4 PCI Configuration Registers	561
A-2	Intel® ICH4 Fixed I/O Registers.....	571
A-3	Intel® ICH4 Variable I/O Registers.....	573



This page is intentionally left blank

Revision History

Revision	Description	Date
-001	Initial release	May 2002

Introduction

1

1.1 About This Datasheet

This datasheet is intended for Original Equipment Manufacturers and BIOS vendors creating ICH4-based products. This datasheet assumes a working knowledge of the vocabulary and principles of USB, IDE, AC '97, SMBus, PCI, ACPI and LPC. Although some details of these features are described within this datasheet, refer to the individual industry specifications listed in [Table 1-1](#) for the complete details.

Table 1-1. Industry Specifications

Specification	Location
<i>Low Pin Count Interface Specification, Revision 1.0 (LPC)</i>	http://developer.intel.com/design/chipsets/industry/lpc.htm
<i>Audio Codec '97 Component Specification, Version 2.3 (AC '97)</i>	http://developer.intel.com/ial/scalableplatforms/audio/index.htm
<i>Wired for Management Baseline, Version 2.0 (WfM)</i>	http://www.intel.com/labs/manage/wfm/index.htm
<i>System Management Bus Specification, Version 2.0 (SMBus)</i>	http://www.smbus.org/specs/
<i>PCI Local Bus Specification, Revision 2.2 (PCI)</i>	http://pcisig.com/specifications.htm
<i>ATA Attachment - 6 with Packet Interface (ATA/ATAPI - 6) Specification</i>	http://www.t13.org
<i>Universal Serial Bus (USB) Specification, Revision 2.0</i>	http://www.usb.org
<i>Advanced Configuration and Power Interface (ACPI) Specification, Revision 2.0</i>	http://www.acpi.info
<i>Enhanced Host Controller Interface (EHCI) Specification for Universal Serial Bus, Revision 1.0</i>	http://developer.intel.com/technology/usb/ehcispec.htm

Chapter 1. Introduction

Chapter 1 provides information on datasheet organization and introduces the ICH4.

Chapter 2. Signal Description

Chapter 2 provides a detailed description of each ICH4 signal. Signals are arranged according to interface and details are provided as to the drive characteristics (Input/Output, Open Drain, etc.) of all signals.

Chapter 3. ICH4 Power Planes and Pin States

Chapter 3 provides a complete list of signals, their associated power well, their logic level in each suspend state, and their logic level before and after reset.

Chapter 4. ICH4 and System Clock Domains

Chapter 4 provides a list of each clock domain associated with the ICH4 in an ICH4-based system.

Chapter 5. Functional Description

Chapter 5 provides a detailed description of the functions in the ICH4. All PCI buses, devices, and functions in this datasheet are abbreviated using the following nomenclature;

Bus:Device:Function. This datasheet abbreviates buses as B0 and B1, devices as D8, D29, D30 and D31 and functions as F0, F1, F2, F3, F4, F5, F6 and F7. For example Device 31 Function 5 is abbreviated as D31:F5, Bus 1 Device 8 Function 0 is abbreviated as B1:D8:F0. Generally, the bus number will not be used, and can be considered to be Bus 0. Note that the ICH4's external PCI bus is typically Bus 1, but may be assigned a different number depending upon system configuration.

Chapter 6. Register, Memory and I/O Address Maps

Chapter 6 provides an overview of the registers, fixed I/O ranges, variable I/O ranges and memory ranges decoded by the ICH4.

Chapter 7. LAN Controller Registers

Chapter 7 provides a detailed description of all registers that reside in the ICH4's integrated LAN controller. The integrated LAN controller resides on the ICH4's external PCI bus (typically Bus 1) at Device 8, Function 0 (B1:D8:F0).

Chapter 8. Hub Interface to PCI Bridge Registers

Chapter 8 provides a detailed description of all registers that reside in the Hub Interface to PCI bridge. This bridge resides at Device 30, Function 0 (D30:F0).

Chapter 9. LPC Bridge Registers

Chapter 9 provides a detailed description of all registers that reside in the LPC bridge. This bridge resides at Device 31, Function 0 (D31:F0). This function contains registers for many different units within the ICH4 including DMA, Timers, Interrupts, CPU Interface, GPIO, Power Management, System Management and RTC.

Chapter 10. IDE Controller Registers

Chapter 10 provides a detailed description of all registers that reside in the IDE controller. This controller resides at Device 31, Function 1 (D31:F1).

Chapter 11. USB UHCI Controller Registers

Chapter 11 provides a detailed description of all registers that reside in the three UHCI host controllers. These controllers reside at Device 29, Functions 0, 1 and 2 (D29:F0/F1/F2).

Chapter 12. USB EHCI Controller Registers

Chapter 12 provides a detailed description of all registers that reside in the EHCI host controller. This controller resides at Device 29, Function 7 (D29:F7).

Chapter 13. SMBus Controller Registers

Chapter 13 provides a detailed description of all registers that reside in the SMBus controller. This controller resides at Device 31, Function 3 (D31:F3).

Chapter 14. AC '97 Audio Controller Registers

Chapter 14 provides a detailed description of all registers that reside in the audio controller. This controller resides at Device 31, Function 5 (D31:F5). Note that this chapter of the datasheet does not include the native audio mixer registers. Accesses to the mixer registers are forwarded over the AC-link to the codec where the registers reside.

Chapter 15. AC '97 Modem Controller Registers

Chapter 15 provides a detailed description of all registers that reside in the modem controller. This controller resides at Device 31, Function 6 (D31:F6). Note that this chapter of the datasheet does not include the modem mixer registers. Accesses to the mixer registers are forwarded over the AC-link to the codec where the registers reside.

Chapter 16. Pinout Definition

Chapter 16 provides a table of each signal and its ball assignment in the 421 BGA package.

Chapter 17. Electrical Characteristics

Chapter 17 provides all AC and DC characteristics including detailed timing diagrams.

Chapter 18. Package Information

Chapter 18 provides drawings of the physical dimensions and characteristics of the 421-BGA package.

Chapter 19. Testability

Chapter 19 provides detail about the implementation of test modes provided in the ICH4.

Index

This document ends with indexes of registers and register bits.

1.2 Overview

The ICH4 provides extensive I/O support. Functions and capabilities include:

- *PCI Local Bus Specification*, Revision 2.2-compliant with support for 33 MHz PCI operations.
- PCI slots (supports up to 6 Req/Gnt pairs)
- ACPI Power Management Logic Support
- Enhanced DMA controller, Interrupt controller, and timer functions
- Integrated IDE controller supports Ultra ATA100/66/33
- USB host interface with support for 6 USB ports; 3 UHCI host controllers; 1 EHCI high-speed USB 2.0 Host controller
- Integrated LAN controller
- *System Management Bus (SMBus) Specification*, Version 2.0 with additional support for I²C devices
- Supports *Audio Codec '97*, Revision 2.3 specification (a.k.a., *AC '97 Component Specification*, Revision 2.3) Link for Audio and Telephony codecs (up to seven channels)
- Low Pin Count (LPC) interface
- Firmware Hub (FWH) interface support
- Alert On LAN* (AOL) and Alert On LAN 2* (AOL2)

The ICH4 incorporates a variety of PCI functions that are divided into three logical devices (29, 30, and 31) on PCI Bus 0 and one device on Bus 1. Device 30 is the Hub Interface-To-PCI bridge. Device 31 contains all the other PCI functions, except the USB controllers and the LAN controller, as shown in [Table 1-2](#). The LAN controller is located on Bus 1.

Table 1-2. PCI Devices and Functions

Bus:Device:Function	Function Description
Bus 0:Device 30:Function 0	Hub Interface to PCI Bridge
Bus 0:Device 31:Function 0	PCI to LPC Bridge
Bus 0:Device 31:Function 1	IDE Controller
Bus 0:Device 31:Function 3	SMBus Controller
Bus 0:Device 31:Function 5	AC '97 Audio Controller
Bus 0:Device 31:Function 6	AC '97 Modem Controller
Bus 0:Device 29:Function 0	USB UHCI Controller #1
Bus 0:Device 29:Function 1	USB UHCI Controller #2
Bus 0:Device 29:Function 2	USB UHCI Controller #3
Bus 0:Device 29:Function 7	USB 2.0 EHCI Controller
Bus n:Device 8:Function 0	LAN Controller

The following sub-sections provide an overview of the ICH4 capabilities.

Hub Architecture

As I/O speeds increase, the demand placed on the PCI bus by the I/O bridge has become significant. With AC '97, USB 2.0, and Ultra ATA/100, coupled with the existing USB, I/O requirements could impact PCI bus performance. The chipset's *hub interface architecture* ensures that the I/O subsystem; both PCI and the integrated I/O features (IDE, AC '97, USB, etc.), receive adequate bandwidth. By placing the I/O bridge on the hub interface (instead of PCI), the hub architecture ensures that both the I/O functions integrated into the ICH4 and the PCI peripherals obtain the bandwidth necessary for peak performance.

PCI Interface

The ICH4 PCI interface provides a 33 MHz, Rev. 2.2 compliant implementation. All PCI signals are 5 V tolerant, except PME#. The ICH4 integrates a PCI arbiter that supports up to six external PCI bus masters in addition to the internal ICH4 requests.

IDE Interface (Bus Master Capability and Synchronous DMA Mode)

The fast IDE interface supports up to four IDE devices providing an interface for IDE hard disks and ATAPI devices. Each IDE device can have independent timings. The IDE interface supports PIO IDE transfers up to 16 Mbytes/sec and Ultra ATA transfers up to 100 Mbytes/sec. It does not consume any ISA DMA resources. The IDE interface integrates 16x32-bit buffers for optimal transfers.

The ICH4's IDE system contains two independent IDE signal channels. They can be electrically isolated independently. They can be configured to the standard primary and secondary channels (four devices). There are integrated series resistors on the data and control lines (see [Section 5.15](#) for details).

Low Pin Count (LPC) Interface

The ICH4 implements an LPC Interface as described in the LPC 1.0 specification. The Low Pin Count (LPC) Bridge function of the ICH4 resides in PCI Device 31:Function 0. In addition to the LPC bridge interface function, D31:F0 contains other functional units including DMA, Interrupt controllers, Timers, Power Management, System Management, GPIO, and RTC.

Note that in the current chipset platform, the Super I/O (SIO) component has migrated to the Low Pin Count (LPC) interface. Migration to the LPC interface allows for lower cost Super I/O designs.

Compatibility Modules (DMA Controller, Timer/Counters, Interrupt Controller)

The DMA controller incorporates the logic of two 82C37 DMA controllers, with seven independently programmable channels. Channels 0–3 are hardwired to 8-bit, count-by-byte transfers, and channels 5–7 are hardwired to 16-bit, count-by-word transfers. Any two of the seven DMA channels can be programmed to support fast Type-F transfers.

The ICH4 supports two types of DMA (LPC and PC/PCI). DMA via LPC is similar to ISA DMA. LPC DMA and PC/PCI DMA use the ICH4's DMA controller. The PC/PCI protocol allows PCI-based peripherals to initiate DMA cycles by encoding requests and grants via two PC/PCI REQ#/GNT# pairs.

LPC DMA is handled through the use of the LDRQ# lines from peripherals and special encodings on LAD[3:0] from the host. Single, Demand, Verify, and Increment modes are supported on the LPC interface. Channels 0–3 are 8-bit channels. Channels 5–7 are 16-bit channels. Channel 4 is reserved as a generic bus master request.

The timer/counter block contains three counters that are equivalent in function to those found in one 82C54 programmable interval timer. These three counters are combined to provide the system timer function, and speaker tone. The 14.31818 MHz oscillator input provides the clock source for these three counters.

The ICH4 provides an ISA-Compatible Programmable Interrupt Controller (PIC) that incorporates the functionality of two 82C59 interrupt controllers. The two interrupt controllers are cascaded so that 14 external and two internal interrupts are possible. In addition, the ICH4 supports a serial interrupt scheme.

All of the registers in these modules can be read and restored. This is required to save and restore system state after power has been removed and restored to the platform.

Advanced Programmable Interrupt Controller (APIC)

In addition to the standard ISA compatible Programmable Interrupt Controller (PIC) described in the previous section, the ICH4 incorporates the Advanced Programmable Interrupt Controller (APIC).

Universal Serial Bus (USB) Controller

The ICH4 contains an Enhanced Host Controller Interface (EHCI) compliant host controller that supports USB high-speed signaling. High-speed USB 2.0 allows data transfers up to 480 Mb/s which is 40 times faster than full-speed USB. The ICH4 also contains three Universal Host Controller Interface (UHCI) controllers that support USB full-speed and low-speed signaling.

The ICH4 supports 6 USB 2.0 ports. All six ports are high-speed, full-speed, and low-speed capable. ICH4's port-routing logic determines whether a USB port is controlled by one of the UHCI controllers or by the EHCI controller. See [Section 5.16, "USB UHCI Controllers \(D29:F0, F1 and F2\)](#) and [Section 5.17, "USB EHCI Controller \(D29:F7\)](#) for details.

LAN Controller

The ICH4's integrated LAN controller includes a 32-bit PCI controller that provides enhanced scatter-gather bus mastering capabilities and enables the LAN controller to perform high-speed data transfers over the PCI bus. Its bus master capabilities enable the component to process high-level commands and perform multiple operations; this lowers processor utilization by off-loading communication tasks from the processor. Two large transmit and receive FIFOs of 3 KB each help prevent data underruns and overruns while waiting for bus accesses. This enables the integrated LAN controller to transmit data with minimum interframe spacing (IFS).

The LAN controller can operate in either full duplex or half duplex mode. In full duplex mode the LAN controller adheres with the IEEE 802.3x Flow Control specification. Half duplex performance is enhanced by a proprietary collision reduction mechanism. See [Section 5.2](#) for details.

RTC

The ICH4 contains a Motorola MC146818A-compatible real-time clock with 256 bytes of battery-backed RAM. The real-time clock performs two key functions: keeping track of the time of day and storing system data, even when the system is powered down. The RTC operates on a 32.768 KHz crystal and a separate 3 V lithium battery that provides up to seven years of protection.

The RTC also supports two lockable memory ranges. By setting bits in the configuration space, two 8-byte ranges can be locked to read and write accesses. This prevents unauthorized reading of passwords or other system security information.

The RTC also supports a date alarm that allows for scheduling a wake up event up to 30 days in advance, rather than just 24 hours in advance.

GPIO

Various general purpose inputs and outputs are provided for custom system design. The number of inputs and outputs varies depending on ICH4 configuration.

Enhanced Power Management

The ICH4's power management functions include enhanced clock control, local and global monitoring support for 14 individual devices, and various low-power (suspend) states (e.g., Suspend-to-DRAM and Suspend-to-Disk). A hardware-based thermal management circuit permits software-independent entrance to low-power states. The ICH4 contains full support for the *Advanced Configuration and Power Interface (ACPI) Specification, Revision 2.0*.

System Management Bus (SMBus 2.0)

The ICH4 contains an SMBus Host interface that allows the processor to communicate with SMBus slaves. This interface is compatible with most I²C devices. Special I²C commands are implemented.

The ICH4's SMBus host controller provides a mechanism for the processor to initiate communications with SMBus peripherals (slaves). Also, the ICH4 supports slave functionality, including the Host Notify protocol. Hence, the host controller supports 8 command protocols of the SMBus interface (see *System Management Bus (SMBus) Specification, Version 2.0*): Quick Command, Send Byte, Receive Byte, Write Byte/Word, Read Byte/Word, Process Call, Block Read/Write, and Host Notify.

Manageability

The ICH4 integrates several functions designed to manage the system and lower the total cost of ownership (TCO) of the system. These system management functions are designed to report errors, diagnose the system, and recover from system lockups without the aid of an external microcontroller.

- **TCO Timer.** The ICH4's integrated programmable TCO Timer is used to detect system locks. The first expiration of the timer generates an SMI# that the system can use to recover from a software lock. The second expiration of the timer causes a system reset to recover from a hardware lock.
- **Processor Present Indicator.** The ICH4 looks for the processor to fetch the first instruction after reset. If the processor does not fetch the first instruction, the ICH4 will reboot the system.
- **ECC Error Reporting.** When detecting an ECC error, the host controller has the ability to send one of several messages to the ICH4. The host controller can instruct the ICH4 to generate either an SMI#, NMI, SERR#, or TCO interrupt.
- **Function Disable.** The ICH4 provides the ability to disable the following functions: AC '97 Modem, AC '97 Audio, IDE, LAN, USB, or SMBus. Once disabled, these functions no longer decode I/O, memory, or PCI configuration space. Also, no interrupts or power management events are generated from the disable functions.
- **Intruder Detect.** The ICH4 provides an input signal (INTRUDER#) that can be attached to a switch that is activated by the system case being opened. The ICH4 can be programmed to generate an SMI# or TCO interrupt due to an active INTRUDER# signal.
- **SMBus 2.0.** The ICH4 integrates an SMBus controller that provides an interface to manage peripherals (e.g., serial presence detection (SPD) and thermal sensors) with host notify capabilities.
- **Alert On LAN*.** The ICH4 supports Alert On LAN and Alert On LAN 2. In response to a TCO event (intruder detect, thermal event, processor not booting) the ICH4 sends a message over the SMBus. A LAN controller can decode this SMBus message and send a message over the network to alert the network manager.

AC '97 2.3 Controller

The *Audio Codec '97*, Revision 2.3 specification defines a digital interface that can be used to attach an audio codec (AC), a modem codec (MC), an audio/modem codec (AMC) or a combination of ACs and MC. The AC '97 specification defines the interface between the system logic and the audio or modem codec, known as the AC-link.

By using an audio codec, the AC-link allows for cost-effective, high-quality, integrated audio on Intel's chipset-based platform. In addition, an AC '97 soft modem can be implemented with the use of a modem codec. Several system options exist when implementing AC '97. The ICH4-integrated digital link allows several external codecs to be connected to the ICH4. The system designer can provide audio with an audio codec, a modem with a modem codec, or an integrated audio/modem codec. The digital link is expanded to support three audio codecs or two audio codecs and one modem codec.

The modem implementations for different countries must be taken into consideration, because telephone systems may vary. By using a split design, the audio codecs can be on-board and the modem codec can be placed on a riser.

The digital link in the ICH4 supports the *Audio Codec '97*, Revision 2.3 specification, so it supports three codecs with independent PCI functions for audio and modem. Microphone input and left and right audio channels are supported for a high quality, two-speaker audio solution. Wake on Ring from Suspend also is supported with the appropriate modem codec.

The ICH4 expands the audio capability with support for up to six channels of PCM audio output (full AC3 decode). Six-channel audio consists of Front Left, Front Right, Back Left, Back Right, Center, and Subwoofer, for a complete surround-sound effect. ICH4 has expanded support for three audio codecs on the AC-link.



This page is intentionally left blank.

Signal Description

2

This section provides a detailed description of each signal. The signals are arranged in functional groups according to their associated interface.

The “#” symbol at the end of the signal name indicates that the active, or asserted state occurs when the signal is at a low voltage level. When “#” is not present, the signal is asserted when at the high voltage level.

The following notations are used to describe the signal type:

I	Input Pin
O	Output Pin
OD	Open Drain Output Pin.
I/O	Bi-directional Input / Output Pin.

Figure 2-1. Intel® ICH4 Interface Signals Block Diagram

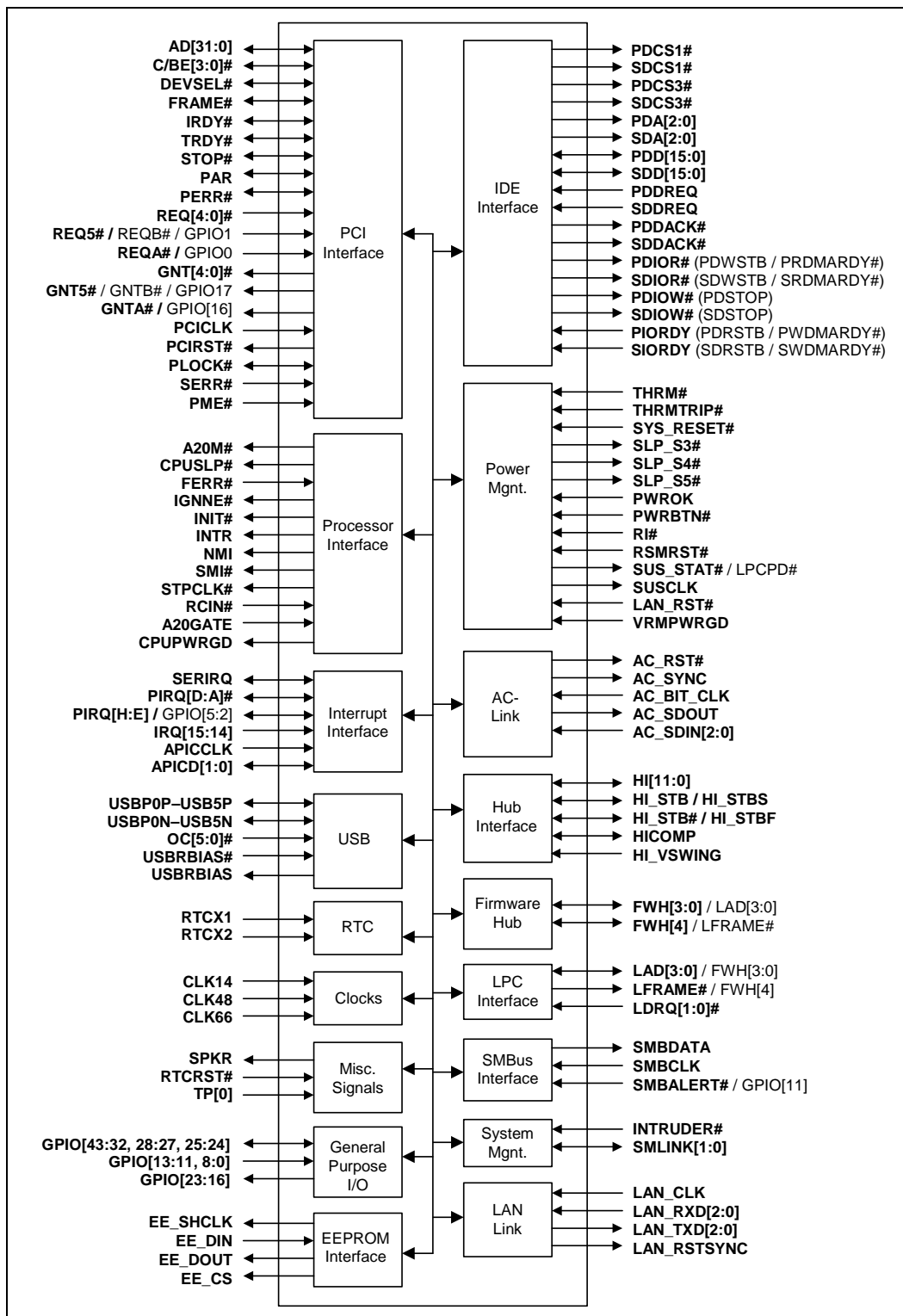

2.1 Hub Interface to Host Controller

Table 2-1. Hub Interface Signals

Name	Type	Description
HI[11:0]	I/O	Hub Interface Signals
HI_STB / HI_STBS	I/O	Hub Interface Strobe/ Hub Interface Strobe Second: One of two differential strobe signals used to transmit and receive data through the hub interface. Hub Interface 1.5 mode this signal is not differential and is the second of the two strobe signals.
HI_STB# / HI_STBF	I/O	Hub Interface Strobe Complement / Hub Interface Strobe First: One of two differential strobe signals used to transmit and receive data through the hub interface. Hub Interface 1.5 mode this signal is not differential and is the first of the two strobe signals.
HICOMP	I/O	Hub Interface Compensation: Used for hub interface buffer compensation.
HI_VSWING	I	Hub Interface Voltage Swing: Analog input used to control the voltage swing and impedance strength of hub interface pins. NOTES: 1. Refer to the platform design guide for expected voltages. 2. Refer to the platform design guide for resistor values and routing guidelines for each hub interface mode.

2.2 Link to LAN Connect

Table 2-2. LAN Connect Interface Signals

Name	Type	Description
LAN_CLK	I	LAN I/F Clock: Driven by the LAN Connect component. Frequency range is 5 MHz to 50 MHz.
LAN_RXD[2:0]	I	Received Data: The LAN Connect component uses these signals to transfer data and control information to the integrated LAN controller. These signals have integrated weak pull-up resistors.
LAN_TXD[2:0]	O	Transmit Data: The integrated LAN controller uses these signals to transfer data and control information to the LAN Connect component.
LAN_RSTSYNC	O	LAN Reset/Sync: The LAN Connect component's Reset and Sync signals are multiplexed onto this pin.

2.3 EEPROM Interface

Table 2-3. EEPROM Interface Signals

Name	Type	Description
EE_SHCLK	O	EEPROM Shift Clock: This signal is the serial shift clock output to the EEPROM.
EE_DIN	I	EEPROM Data In: This signal transfers data from the EEPROM to the Intel [®] ICH4. This signal has an integrated pull-up resistor.
EE_DOUT	O	EEPROM Data Out: EE_DOUT transfers data from the ICH4 to the EEPROM.
EE_CS	O	EEPROM Chip Select: EE_CS is the chip select signal to the EEPROM.

2.4 Firmware Hub Interface

Table 2-4. Firmware Hub Interface Signals

Name	Type	Description
FWH[3:0] / LAD[3:0]	I/O	Firmware Hub Signals: FWH[3:0] are muxed with LPC address signals.
FWH[4] / LFRAME#	I/O	Firmware Hub Signals: FWH[4] is muxed with the LPC LFRAME# signal.

2.5 PCI Interface

Table 2-5. PCI Interface Signals (Sheet 1 of 3)

Name	Type	Description																								
AD[31:0]	I/O	PCI Address/Data: AD[31:0] is a multiplexed address and data bus. During the first clock of a transaction, AD[31:0] contain a physical address (32 bits). During subsequent clocks, AD[31:0] contain data. The Intel [®] ICH4 drives all 0s on AD[31:0] during the address phase of all PCI Special Cycles.																								
C/BE[3:0]#	I/O	<p>Bus Command and Byte Enables: The command and byte enable signals are multiplexed on the same PCI pins. During the address phase of a transaction, C/BE[3:0]# define the bus command. During the data phase, C/BE[3:0]# define the Byte Enables.</p> <table border="1"> <thead> <tr> <th>C/BE[3:0]#</th> <th>Command Type</th> </tr> </thead> <tbody> <tr><td>0 0 0 0</td><td>Interrupt Acknowledge</td></tr> <tr><td>0 0 0 1</td><td>Special Cycle</td></tr> <tr><td>0 0 1 0</td><td>I/O Read</td></tr> <tr><td>0 0 1 1</td><td>I/O Write</td></tr> <tr><td>0 1 1 0</td><td>Memory Read</td></tr> <tr><td>0 1 1 1</td><td>Memory Write</td></tr> <tr><td>1 0 1 0</td><td>Configuration Read</td></tr> <tr><td>1 0 1 1</td><td>Configuration Write</td></tr> <tr><td>1 1 0 0</td><td>Memory Read Multiple</td></tr> <tr><td>1 1 1 0</td><td>Memory Read Line</td></tr> <tr><td>1 1 1 1</td><td>Memory Write and Invalidate</td></tr> </tbody> </table> <p>All command encodings not shown are reserved. The ICH4 does not decode reserved values, and therefore will not respond if a PCI master generates a cycle using one of the reserved values.</p>	C/BE[3:0]#	Command Type	0 0 0 0	Interrupt Acknowledge	0 0 0 1	Special Cycle	0 0 1 0	I/O Read	0 0 1 1	I/O Write	0 1 1 0	Memory Read	0 1 1 1	Memory Write	1 0 1 0	Configuration Read	1 0 1 1	Configuration Write	1 1 0 0	Memory Read Multiple	1 1 1 0	Memory Read Line	1 1 1 1	Memory Write and Invalidate
C/BE[3:0]#	Command Type																									
0 0 0 0	Interrupt Acknowledge																									
0 0 0 1	Special Cycle																									
0 0 1 0	I/O Read																									
0 0 1 1	I/O Write																									
0 1 1 0	Memory Read																									
0 1 1 1	Memory Write																									
1 0 1 0	Configuration Read																									
1 0 1 1	Configuration Write																									
1 1 0 0	Memory Read Multiple																									
1 1 1 0	Memory Read Line																									
1 1 1 1	Memory Write and Invalidate																									

Table 2-5. PCI Interface Signals (Sheet 2 of 3)

Name	Type	Description
DEVSEL#	I/O	Device Select: The ICH4 asserts DEVSEL# to claim a PCI transaction. As an output, the ICH4 asserts DEVSEL# when a PCI master peripheral attempts an access to an internal ICH4 address or an address destined for the hub interface (main memory or AGP). As an input, DEVSEL# indicates the response to an ICH4-initiated transaction on the PCI bus. DEVSEL# is tri-stated from the leading edge of PCIRST#. DEVSEL# remains tri-stated by the ICH4 until driven by a Target device.
FRAME#	I/O	Cycle Frame: The current Initiator drives FRAME# to indicate the beginning and duration of a PCI transaction. While the Initiator asserts FRAME#, data transfers continue. When the Initiator negates FRAME#, the transaction is in the final data phase. FRAME# is an input to the ICH4 when the ICH4 is the Target, and FRAME# is an output from the ICH4 when the ICH4 is the Initiator. FRAME# remains tri-stated by the ICH4 until driven by an Initiator.
IRDY#	I/O	Initiator Ready: IRDY# indicates the ICH4's ability, as an Initiator, to complete the current data phase of the transaction. It is used in conjunction with TRDY#. A data phase is completed on any clock that both IRDY# and TRDY# are sampled asserted. During a write, IRDY# indicates the ICH4 has valid data present on AD[31:0]. During a read, it indicates the ICH4 is prepared to latch data. IRDY# is an input to the ICH4 when the ICH4 is the Target and an output from the ICH4 when the ICH4 is an Initiator. IRDY# remains tri-stated by the ICH4 until driven by an Initiator.
TRDY#	I/O	Target Ready: TRDY# indicates the ICH4's ability, as a Target, to complete the current data phase of the transaction. TRDY# is used in conjunction with IRDY#. A data phase is completed when both TRDY# and IRDY# are sampled asserted. During a read, TRDY# indicates that the ICH4, as a Target, has placed valid data on AD[31:0]. During a write, TRDY# indicates that the ICH4, as a Target, is prepared to latch data. TRDY# is an input to the ICH4 when the ICH4 is the Initiator and an output from the ICH4 when the ICH4 is a Target. TRDY# is tri-stated from the leading edge of PCIRST#. TRDY# remains tri-stated by the ICH4 until driven by a Target.
STOP#	I/O	Stop: STOP# indicates that the ICH4, as a Target, is requesting the Initiator to stop the current transaction. STOP# causes the ICH4, as an Initiator, to stop the current transaction. STOP# is an output when the ICH4 is a Target and an input when the ICH4 is an Initiator. STOP# is tri-stated from the leading edge of PCIRST#. STOP# remains tri-stated until driven by the ICH4.
PAR	I/O	Calculated/Checked Parity: PAR uses "even" parity calculated on 36 bits, AD[31:0] plus C/BE[3:0]#. "Even" parity means that the ICH4 counts the number of 1s within the 36 bits plus PAR and the sum is always even. The ICH4 always calculates PAR on 36 bits regardless of the valid byte enables. The ICH4 generates PAR for address and data phases and only guarantees PAR to be valid one PCI clock after the corresponding address or data phase. The ICH4 drives and tri-states PAR identically to the AD[31:0] lines except that the ICH4 delays PAR by exactly one PCI clock. PAR is an output during the address phase (delayed one clock) for all ICH4 initiated transactions. PAR is an output during the data phase (delayed one clock) when the ICH4 is the Initiator of a PCI write transaction, and when it is the Target of a read transaction. ICH4 checks parity when it is the Target of a PCI write transaction. If a parity error is detected, the ICH4 will set the appropriate internal status bits, and has the option to generate an NMI# or SMI#.
PERR#	I/O	Parity Error: An external PCI device drives PERR# when it receives data that has a parity error. The ICH4 drives PERR# when it detects a parity error. The ICH4 can either generate an NMI# or SMI# upon detecting a parity error (either detected internally or reported via the PERR# signal).
REQ[0:4]# REQ[5]# / REQ[B]# / GPIO[1]	I	PCI Requests: The ICH4 supports up to 6 masters on the PCI bus. REQ[5]# is muxed with PC/PCI REQ[B]# (must choose one or the other, but not both). If not used for PCI or PC/PCI, REQ[5]#/REQ[B]# can instead be used as GPIO[1]. NOTE: REQ[0]# is programmable to have improved arbitration latency for supporting PCI-based 1394 controllers.

Table 2-5. PCI Interface Signals (Sheet 3 of 3)

Name	Type	Description
GNT[0:4]# GNT[5]# / GNT[B]# / GPIO[17]#	O	PCI Grants: The ICH4 supports up to 6 masters on the PCI bus. GNT[5]# is muxed with PC/PCI GNT[B]# (must choose one or the other, but not both). If not needed for PCI or PC/PCI, GNT[5]# can instead be used as a GPIO. Pull-up resistors are not required on these signals. If pull-ups are used, they should be tied to the Vcc3_3 power rail. GNT[B]#/GNT[5]#/GPIO[17] has an internal pull-up.
PCICLK	I	NOTE: PCI Clock: This is a 33 MHz clock. PCICLK provides timing for all transactions on the PCI Bus.
PCIRST#	O	PCI Reset: ICH4 asserts PCIRST# to reset devices that reside on the PCI bus. The ICH4 asserts PCIRST# during power-up and when S/W initiates a hard reset sequence through the RC (CF9h) register. The ICH4 drives PCIRST# inactive a minimum of 1 ms after PWROK is driven active. The ICH4 drives PCIRST# active a minimum of 1 ms when initiated through the RC register.
PLOCK#	I/O	PCI Lock: This signal indicates an exclusive bus operation and may require multiple transactions to complete. ICH4 asserts PLOCK# when it performs non-exclusive transactions on the PCI bus. PLOCK# is ignored when PCI masters are granted the bus.
SERR#	I/OD	System Error: SERR# can be pulsed active by any PCI device that detects a system error condition. Upon sampling SERR# active, the ICH4 has the ability to generate an NMI, SMI#, or interrupt.
PME#	I/OD	PCI Power Management Event: PCI peripherals drive PME# to wake the system from low-power states S1–S5. PME# assertion can also be enabled to generate an SCI from the S0 state. In some cases the ICH4 may drive PME# active due to an internal wake event. The ICH4 will not drive PME# high, but it will be pulled up to VccSus3_3 by an internal pull-up resistor.
REQ[A]# / GPIO[0] REQ[B]# / REQ[5]# / GPIO[1]	I	PC/PCI DMA Request [A:B]: This request serializes ISA-like DMA Requests for the purpose of running ISA-compatible DMA cycles over the PCI bus. This is used by devices such as PCI based Super I/O or audio codecs which need to perform legacy 8237 DMA but have no ISA bus. When not used for PC/PCI requests, these signals can be used as General Purpose Inputs. REQ[B]# can instead be used as the 6th PCI bus request.
GNT[A]# / GPIO[16] GNT[B]# / GNT[5]# / GPIO[17]	O	PC/PCI DMA Acknowledges [A: B]: This grant serializes an ISA-like DACK# for the purpose of running DMA/ISA Master cycles over the PCI bus. This is used by devices such as PCI based Super/I/O or audio codecs which need to perform legacy 8237 DMA but have no ISA bus. When not used for PC/PCI, these signals can be used as General Purpose Outputs. GNTB# can also be used as the 6th PCI bus master grant output. These signal have internal pull-up resistors.

2.6 IDE Interface

Table 2-6. IDE Interface Signals

Name	Type	Description
PDCS1#, SDCS1#	O	Primary and Secondary IDE Device Chip Selects for 100 Range: For ATA command register block. This output signal is connected to the corresponding signal on the primary or secondary IDE connector.
PDCS3#, SDCS3#	O	Primary and Secondary IDE Device Chip Select for 300 Range: For ATA control register block. This output signal is connected to the corresponding signal on the primary or secondary IDE connector.
PDA[2:0], SDA[2:0]	O	Primary and Secondary IDE Device Address: These output signals are connected to the corresponding signals on the primary or secondary IDE connectors. They are used to indicate which byte in either the ATA command block or control block is being addressed.
PDD[15:0], SDD[15:0]	I/O	Primary and Secondary IDE Device Data: These signals directly drive the corresponding signals on the primary or secondary IDE connector. There is a weak internal pull-down resistor on PDD[7] and SDD[7].
PDDREQ, SDDREQ	I	Primary and Secondary IDE Device DMA Request: These input signals are directly driven from the DRQ signals on the primary or secondary IDE connector. It is asserted by the IDE device to request a data transfer, and used in conjunction with the PCI bus master IDE function and are not associated with any AT compatible DMA channel. There is a weak internal pull-down resistor on these signals.
PDDACK#, SDDACK#	O	Primary and Secondary IDE Device DMA Acknowledge: These signals directly drive the DAK# signals on the primary and secondary IDE connectors. Each is asserted by the Intel® ICH4 to indicate to IDE DMA slave devices that a given data transfer cycle (assertion of DIOR# or DIOW#) is a DMA data transfer cycle. This signal is used in conjunction with the PCI bus master IDE function and are not associated with any AT-compatible DMA channel.
PDIOR# / (PDWSTB / PRDMARDY#) SDIOR# / (SDWSTB / SRDMARDY#)	O	Primary and Secondary Disk I/O Read (PIO and Non-Ultra DMA): This is the command to the IDE device that it may drive data onto the PDD or SDD lines. Data is latched by the ICH4 on the deassertion edge of PDIOR# or SDIOR#. The IDE device is selected either by the ATA register file chip selects (PDCS1# or SDCS1#, PDCS3# or SDCS3#) and the PDA or SDA lines, or the IDE DMA acknowledge (PDDAK# or SDDAK#). Primary and Secondary Disk Write Strobe (Ultra DMA Writes to Disk): This is the data write strobe for writes to disk. When writing to disk, ICH4 drives valid data on rising and falling edges of PDWSTB or SDWSTB. Primary and Secondary Disk DMA Ready (Ultra DMA Reads from Disk): This is the DMA ready for reads from disk. When reading from disk, ICH4 deasserts PRDMARDY# or SRDMARDY# to pause burst data transfers.
PDIOW# / (PDSTOP) SDIOW# / (SDSTOP)	O	Primary and Secondary Disk I/O Write (PIO and Non-Ultra DMA): This is the command to the IDE device that it may latch data from the PDD or SDD lines. Data is latched by the IDE device on the deassertion edge of PDIOW# or SDIOW#. The IDE device is selected either by the ATA register file chip selects (PDCS1# or SDCS1#, PDCS3# or SDCS3#) and the PDA or SDA lines, or the IDE DMA acknowledge (PDDAK# or SDDAK#). Primary and Secondary Disk Stop (Ultra DMA): ICH4 asserts this signal to terminate a burst.
PIORDY / (PDRSTB / PWRDMARDY#) SIORDY / (SDRSTB / SWDMARDY#)	I	Primary and Secondary I/O Channel Ready (PIO): This signal will keep the strobe active (PDIOR# or SDIOR# on reads, PDIOW# or SDIOW# on writes) longer than the minimum width. It adds wait states to PIO transfers. Primary and Secondary Disk Read Strobe (Ultra DMA Reads from Disk): When reading from disk, ICH4 latches data on rising and falling edges of this signal from the disk. Primary and Secondary Disk DMA Ready (Ultra DMA Writes to Disk): When writing to disk, this is de-asserted by the disk to pause burst data transfers.

2.7 LPC Interface

Table 2-7. LPC Interface Signals

Name	Type	Description
LAD[3:0] / FWH[3:0]	I/O	LPC Multiplexed Command, Address, Data: For the LAD[3:0] signals, internal pull-ups are provided.
LFRAME# / FWH[4]	O	LPC Frame: LFRAME# indicates the start of an LPC cycle, or an abort.
LDRQ[1:0]#	I	LPC Serial DMA/Master Request Inputs: LDRQ[1:0]# are used to request DMA or bus master access. These signals are typically connected to an external Super I/O device. An internal pull-up resistor is provided on these signals.

2.8 Interrupt Interface

Table 2-8. Interrupt Signals

Name	Type	Description
SERIRQ	I/O	Serial Interrupt Request: This pin implements the serial interrupt protocol.
PIRQ[D:A]#	I/OD	PCI Interrupt Requests: In Non-APIC Mode the PIRQx# signals can be routed to interrupts 3, 4, 5, 6, 7, 9, 10, 11, 12, 14 or 15 as described in the Interrupt Steering section. Each PIRQx# line has a separate Route Control Register. In APIC mode, these signals are connected to the internal I/O APIC in the following fashion: PIRQ[A]# is connected to IRQ16, PIRQ[B]# to IRQ17, PIRQ[C]# to IRQ18, and PIRQ[D]# to IRQ19. This frees the legacy interrupts.
PIRQ[H:E]# / GPIO[5:2]	I/OD	PCI Interrupt Requests: In Non-APIC Mode the PIRQx# signals can be routed to interrupts 3, 4, 5, 6, 7, 9, 10, 11, 12, 14 or 15 as described in the Interrupt Steering section. Each PIRQx# line has a separate Route Control Register. In APIC mode, these signals are connected to the internal I/O APIC in the following fashion: PIRQ[E]# is connected to IRQ20, PIRQ[F]# to IRQ21, PIRQ[G]# to IRQ22, and PIRQ[H]# to IRQ23. This frees the legacy interrupts. If not needed for interrupts, these signals can be used as GPIO.
IRQ[14:15]	I	Interrupt Request 14:15: These interrupt inputs are connected to the IDE drives. IRQ14 is used by the drives connected to the Primary controller and IRQ15 is used by the drives connected to the Secondary controller.
APICCLK	I	APIC Clock: This clock operates up to 33.33 MHz.
APICD[1:0]	I/OD	APIC Data: These bi-directional open drain signals are used to send and receive data over the APIC bus. As inputs the data is valid on the rising edge of APICCLK. As outputs, new data is driven from the rising edge of the APICCLK.

2.9 USB Interface

Table 2-9. USB Interface Signals

Name	Type	Description
USBP0P, USBP0N, USBP1P, USBP1N	I/O	Universal Serial Bus Port 1:0 Differential: These differential pairs are used to transmit data/address/command signals for ports 0 and 1. These ports can be routed to USB UHCI controller #1 or the USB EHCI controller. NOTE: No external resistors are required on these signals. The Intel® ICH4 integrates 15 k Ω pull-downs and provides an output driver impedance of 45 Ω which requires no external series resistor
USBP2P, USBP2N, USBP3P, USBP3N	I/O	Universal Serial Bus Port 3:2 Differential: These differential pairs are used to transmit data/address/command signals for ports 2 and 3. These ports can be routed to USB UHCI controller #2 or the USB EHCI controller. NOTE: No external resistors are required on these signals. The ICH4 integrates 15 k Ω pull-downs and provides an output driver impedance of 45 Ω which requires no external series resistor
USBP4P, USBP4N, USBP5P, USBP5N	I/O	Universal Serial Bus Port 5:4 Differential: These differential pairs are used to transmit data/address/command signals for ports 4 and 5. These ports can be routed to USB UHCI controller #3 or the USB EHCI controller. NOTE: No external resistors are required on these signals. The ICH4 integrates 15 k Ω pull-downs and provides an output driver impedance of 45 Ω which requires no external series resistor
OC[5:0]#	I	Overcurrent Indicators: These signals set corresponding bits in the USB controllers to indicate that an overcurrent condition has occurred.
USBRBIAS	O	USB Resistor Bias: Analog connection point for an external resistor to ground. USBRBIAS should be connected to USBRBIAS# as close to the resistor as possible.
USBRBIAS#	I	USB Resistor Bias Complement: Analog connection point for an external resistor to ground. USBRBIAS# should be connected to USBRBIAS as close to the resistor as possible.

2.10 Power Management Interface

Table 2-10. Power Management Interface Signals

Name	Type	Description
THRM#	I	Thermal Alarm: This is an active low signal generated by external hardware to start the hardware clock throttling mode. The signal can also generate an SMI# or an SCI.
THRMTRIP#	I	Thermal Trip: When low, THRMTRIP# indicates that a thermal trip from the processor occurred; the Intel® ICH4 will immediately transition to a S5 state. The ICH4 will not wait for the processor stop grant cycle since the processor has overheated.
SLP_S3#	O	S3 Sleep Control: SLP_S3# is for power plane control. It shuts off power to all non-critical systems when in S3 (Suspend To RAM), S4 (Suspend to Disk), or S5 (Soft Off) states.
SLP_S4#	O	S4 Sleep Control: SLP_S4# is for power plane control. It shuts power to all non-critical systems when in the S4 (Suspend to Disk) or S5 (Soft Off) state.
SLP_S5#	O	S5 Sleep Control: SLP_S5# is for power plane control. The signal is used to shut power off to all non-critical systems when in the S5 (Soft Off) states.
PWROK	I	Power OK: When asserted, PWROK is an indication to the ICH4 that core power and PCICLK have been stable for at least 1 ms. PWROK can be driven asynchronously. When PWROK is negated, the ICH4 asserts PCIRST#. NOTE: PWROK must deassert for a minimum of 3 RTC clock periods for the ICH4 to fully reset the power and properly generate the PCIRST# output
PWRBTN#	I	Power Button: The Power Button causes SMI# or SCI to indicate a system request to go to a sleep state. If the system is already in a sleep state, this signal causes a wake event. If PWRBTN# is pressed for more than 4 seconds, this causes an unconditional transition (power button override) to the S5 state with only the PWRBTN# available as a wake event. Override occurs even if the system is in the S1–S4 states. This signal has an internal pull-up resistor.
RI#	I	Ring Indicate: This signal is an input from the modem interface. It can be enabled as a wake event, and this is preserved across power failures.
SYS_RESET#	I	System Reset: This pin forces an internal reset after being debounced. The ICH4 will reset immediately if the SMBus is idle; otherwise, it will wait up to 25 ms ± 2 ms for the SMBus to idle before forcing a reset on the system.
RSMRST#	I	Resume Well Reset: This signal is used for resetting the resume power plane logic.
LAN_RST#	I	LAN Reset: This signal must be asserted at least 10 ms after the resume well power (VccSus3_3 and VccSus1_5) is valid. When deasserted, this signal is an indication that the resume well power is stable.
SUS_STAT# / LPCPD#	O	Suspend Status: This signal is asserted by the ICH4 to indicate that the system will be entering a low power state soon. This can be monitored by devices with memory that need to switch from normal refresh to suspend refresh mode. It can also be used by other peripherals as an indication that they should isolate their outputs that may be going to powered-off planes. This signal is called LPCPD# on the LPC I/F.
SUSCLK	O	Suspend Clock: Output of the RTC generator circuit to use by other chips for refresh clock.
VRMPWRGD	I	VRM Power Good: This should be connected to be the processor's VRM Power Good.

2.11 Processor Interface

Table 2-11. Processor Interface Signals (Sheet 1 of 2)

Name	Type	Description
A20M#	O	<p>Mask A20: A20M# will go active based on either setting the appropriate bit in the Port 92h register, or based on the A20GATE input being active.</p> <p>Speed Strap: During the reset sequence, Intel® ICH4 drives A20M# high if the corresponding bit is set in the FREQ_STRP register.</p>
CPUSLP#	O	<p>CPU Sleep: This signal puts the processor into a state that saves substantial power compared to Stop-Grant state. However, during that time, no snoops occur. The ICH4 can optionally assert the CPUSLP# signal when going to the S1 state.</p>
FERR#	I	<p>Numeric Coprocessor Error: This signal is tied to the coprocessor error signal on the processor. FERR# is only used if the ICH4 coprocessor error reporting function is enabled in the General Control Register (Device 31:Function 0, Offset D0, bit 13). If FERR# is asserted, the ICH4 generates an internal IRQ13 to its interrupt controller unit. It is also used to gate the IGNNE# signal to ensure that IGNNE# is not asserted to the processor unless FERR# is active. FERR# requires an external weak pull-up to ensure a high level when the coprocessor error function is disabled.</p> <p>NOTE: FERR# can be used in some states for notification by the processor of pending interrupt events. This functionality is independent of the General Control Register bit setting.</p>
IGNNE#	O	<p>Ignore Numeric Error: This signal is connected to the ignore error pin on the processor. IGNNE# is only used if the ICH4 coprocessor error reporting function is enabled in the General Control Register (Device 31:Function 0, Offset D0, bit 13). If FERR# is active, indicating a coprocessor error, a write to the Coprocessor Error Register (F0h) causes the IGNNE# to be asserted. IGNNE# remains asserted until FERR# is negated. If FERR# is not asserted when the Coprocessor Error Register is written, the IGNNE# signal is not asserted.</p> <p>Speed Strap: During the reset sequence, ICH4 drives IGNNE# high if the corresponding bit is set in the FREQ_STRP register.</p>
INIT#	O	<p>Initialization: INIT# is asserted by the ICH4 for 16 PCI clocks to reset the processor. ICH4 can be configured to support CPU BIST. In that case, INIT# will be active when PCIRST# is active.</p>
INTR	O	<p>CPU Interrupt: INTR is asserted by the ICH4 to signal the processor that an interrupt request is pending and needs to be serviced. It is an asynchronous output and normally driven low.</p> <p>Speed Strap: During the reset sequence, ICH4 drives INTR high if the corresponding bit is set in the FREQ_STRP register.</p>
NMI	O	<p>Non-Maskable Interrupt: NMI is used to force a non-Maskable interrupt to the processor. The ICH4 can generate an NMI when either SERR# or IOCHK# is asserted. The processor detects an NMI when it detects a rising edge on NMI. NMI is reset by setting the corresponding NMI source enable/disable bit in the NMI Status and Control Register.</p> <p>Speed Strap: During the reset sequence, ICH4 drives NMI high if the corresponding bit is set in the FREQ_STRP register.</p>
SMI#	O	<p>System Management Interrupt: SMI# is an active low output synchronous to PCICLK. It is asserted by the ICH4 in response to one of many enabled hardware or software events.</p>
STPCLK#	O	<p>Stop Clock Request: STPCLK# is an active low output synchronous to PCICLK. It is asserted by the ICH4 in response to one of many hardware or software events. When the processor samples STPCLK# asserted, it responds by stopping its internal clock.</p>

Table 2-11. Processor Interface Signals (Sheet 2 of 2)

Name	Type	Description
RCIN#	I	Keyboard Controller Reset CPU: The keyboard controller can generate INIT# to the processor. This saves the external OR gate with the ICH4's other sources of INIT#. When the ICH4 detects the assertion of this signal, INIT# is generated for 16 PCI clocks. NOTE: The ICH4 ignores RCIN# assertion during transitions to the S3, S4 and S5 states.
A20GATE	I	A20 Gate: A20GATE is from the keyboard controller. The signal acts as an alternative method to force the A20M# signal active. It saves the external OR gate needed with various other PCIsets.
CPUPWRGD	OD	CPU Power Good: This signal should be connected to the processor's PWRGOOD input. This is an open-drain output signal (external pull-up resistor required) that represents a logical AND of the ICH4's PWROK and VRMPWRGD signals.

2.12 SMBus Interface

Table 2-12. SM Bus Interface Signals

Name	Type	Description
SMBDATA	I/OD	SMBus Data: External pull-up is required.
SMBCLK	I/OD	SMBus Clock: External pull-up is required.
SMBALERT#/GPIO[11]	I	SMBus Alert: This signal is used to wake the system or generate SMI#. If not used for SMBALERT#, it can be used as a GPI.

2.13 System Management Interface

Table 2-13. System Management Interface Signals

Name	Type	Description
INTRUDER#	I	Intruder Detect: This signal can be set to disable the system if the box is detected open. This signal's status is readable, so it can be used like a GPI if the Intruder Detection is not needed.
SMLINK[1:0]	I/OD	System Management Link: SMBus link to optional external system management ASIC or LAN controller. External pull-ups are required. Note that SMLINK[0] corresponds to an SMBus Clock signal and SMLINK[1] corresponds to an SMBus Data signal.

2.14 Real Time Clock Interface

Table 2-14. Real Time Clock Interface

Name	Type	Description
RTCX1	Special	Crystal Input 1: This signal is connected to the 32.768 kHz crystal.
RTCX2	Special	Crystal Input 2: This signal is connected to the 32.768 kHz crystal.

2.15 Other Clocks

Table 2-15. Other Clocks

Name	Type	Description
CLK14	I	Oscillator Clock: This clock is used for 8254 timers. It runs at 14.31818 MHz. This clock is permitted to stop during S3 (or lower) states
CLK48	I	48 MHz Clock: This clock is used to run the USB controllers. It runs at 48 MHz. This clock is permitted to stop during S3 (or lower) states
CLK66	I	66 MHz Clock: This clock is used to run the hub interface. It runs at 66 MHz. This clock is permitted to stop during S3 (or lower) states

2.16 Miscellaneous Signals

Table 2-16. Miscellaneous Signals

Name	Type	Description
SPKR	O	Speaker: The SPKR signal is the output of counter 2 and is internally "ANDed" with Port 61h bit 1 to provide Speaker Data Enable. This signal drives an external speaker driver device, which in turn drives the system speaker. Upon PCIRST#, its output state is 0. NOTE: SPKR is sampled at the rising edge of PWROK as a functional strap. See Section 2.20.1 for more details. There is a weak integrated pull-down resistor on SPKR pin.
RTCRST#	I	RTC Reset: When asserted, this signal resets register bits in the RTC well and sets the RTC_PWR_STS bit (bit 2 in GEN_PMCON3 register). NOTES: 1. Clearing CMOS in an Intel® ICH4-based platform can be done by using a jumper on RTCRST# or GPI, or using SAFEMODE strap. Implementations should not attempt to clear CMOS by using a jumper to pull VccRTC low. 2. Unless entering the XOR Chain Test Mode, the RTCRST# input must always be high when all other RTC power planes are on.
TP[0]	I	Test Point: This signal must have an external pull-up to VccSus3_3.

2.17 AC-Link

Table 2-17. AC-Link Signals

Name	Type	Description
AC_RST#	O	AC97 Reset: This signal is a master hardware reset to external Codec(s).
AC_SYNC	O	AC97 Sync: This signal is a 48 kHz fixed rate sample sync to the Codec(s).
AC_BIT_CLK	I	AC97 Bit Clock: This signal is a 12.288 MHz serial data clock generated by the external Codec(s). This signal has an integrated pull-down resistor (see Note at the end of the table).
AC_SDOOUT	O	AC97 Serial Data Out: Serial TDM data output to the Codec(s). NOTE: AC_SDOOUT is sampled at the rising edge of PWROK as a functional strap. See Section 2.20.1 for more details.
AC_SDIN[2:0]	I	AC97 Serial Data In 2:0: These signals are Serial TDM data inputs from the three Codecs.

NOTE: An integrated pull-down resistor on AC_BIT_CLK is enabled when either:

- The ACLINK Shutoff bit in the AC '97 Global Control Register (See [Section 15.2.8](#)) is set to 1, or
- Both Function 5 and Function 6 of Device 31 are disabled.

Otherwise, the integrated pull-down resistor is disabled.

2.18 General Purpose I/O

Table 2-18. General Purpose I/O Signals

Name	Type	Description
GPIO[47:44]	I/O	Not implemented.
GPIO[43:38]	I/O	Can be input or output. Main power well.
GPIO[37:32]	I/O	Can be input or output. Main power well.
GPIO[31:29]	O	Not implemented.
GPIO[28:27]	I/O	Can be input or output. Resume power well. Unmuxed.
GPIO[26]	I/O	Not implemented.
GPIO[25]	I/O	Can be input or output. Resume power well. Unmuxed.
GPIO[24]	I/O	Can be input or output. Resume power well.
GPIO[23]	O	Fixed as output only. Main power well.
GPIO[22]	OD	Fixed as output only. Main power well.
GPIO[21]	O	Fixed as output only. Main power well.
GPIO[20]	O	Fixed as output only. Main power well.
GPIO[19]	O	Fixed as output only. Main power well.
GPIO[18]	O	Fixed as output only. Main power well.
GPIO[17:16]	O	Fixed as Output only. Main power well. Can be used instead as PC/PCI GNT[A:B]#. GPIO[17] can also alternatively be used for PCI GNT[5]#. Integrated pull-up resistor.
GPIO[15:14]	I	Not implemented.
GPIO[13:12]	I	Fixed as Input only. Resume power well. Unmuxed.
GPIO[11]	I	Fixed as Input only. Resume power well. Can be used instead as SMBALERT#.
GPIO[10:9]	I	Not implemented.
GPIO[8]	I	Fixed as Input only. Resume power well. Unmuxed.
GPIO[7]	I	Fixed as Input only. Main power well. Unmuxed.
GPIO[6]	I	Fixed as Input only. Main power well.
GPIO[5:2]	I	Fixed as Input only. Main power well. Can be used instead as PIRQ[E:H]#.
GPIO[1:0]	I	Fixed as Input only. Main power well. Can be used instead as PC/PCI REQ[A:B]#. GPIO[1] can also alternatively be used for PCI REQ[5]#.

NOTE: Main power well GPIO will be 5 V tolerant, except for GPIO[43:32]. Resume power well GPIO are not 5 V tolerant.

2.19 Power and Ground

Table 2-19. Power and Ground Signals

Name	Description
Vcc3_3	3.3 V supply for core well I/O buffers. This power may be shut off in S3, S4, S5 or G3 states.
Vcc1_5	1.5 V supply for core well logic. This power may be shut off in S3, S4, S5 or G3 states.
VccHI	1.5 V supply for Hub Interface 1.5 logic. 1.8 V supply for Hub Interface 1.0 logic. This power may be shut off in S3, S4, S5 or G3 states.
V5REF	Reference for 5 V tolerance on core well inputs. This power may be shut off in S3, S4, S5 or G3 states.
HIREF	Analog Input. Expected voltages are: <ul style="list-style-type: none"> • 0.9 V for HI 1.0 (Normal Hub Interface) Series Termination • 350 mV for HI 1.5 (Enhanced Hub Interface) Parallel Termination This power is shut off in S3, S4, S5, and G3 states.
VccSus3_3	3.3 V supply for resume well I/O buffers. This power is not expected to be shut off unless the system is unplugged.
VccSus1_5	1.5 V supply for resume well logic. This power is not expected to be shut off unless the system is unplugged.
V5REF_Sus	Reference for 5 V tolerance on resume well inputs. This power is not expected to be shut off unless the system is unplugged.
VccRTC	3.3 V (can drop to 2.0 V min. in G3 state) supply for the RTC well. This power is not expected to be shut off unless the RTC battery is removed or completely drained. NOTE: Implementations should not attempt to clear CMOS by using a jumper to pull VccRTC low. Clearing CMOS in an Intel® ICH4-based platform can be done by using a jumper on RTCRST# or GPI, or using SAFEMODE strap.
VccPLL	1.5 V supply for core well logic. This signal is used for the USB PLL. This power may be shut off in S3, S4, S5, or G3 states.
VBIAS	RTC well bias voltage. The DC reference voltage applied to this pin sets a current that is mirrored throughout the oscillator and buffer circuitry. See Section 2.20.4 .
V_CPU_IO	Powered by the same supply as the processor I/O voltage. This supply is used to drive the processor interface outputs.
Vss	Grounds.

2.20 Pin Straps

2.20.1 Functional Straps

The following signals are used for static configuration. They are sampled at the rising edge of PWROK to select configurations, and then revert later to their normal usage. To invoke the associated mode, the signal should be driven at least four PCI clocks prior to the time it is sampled.

Table 2-20. Functional Strap Definitions

Signal	Usage	When Sampled	Comment
AC_SDOUT	Safe Mode	Rising Edge of PWROK	The signal has a weak internal pull-down. If the signal is sampled high, the Intel® ICH4 will set the processor speed strap pins for safe mode. Refer to processor specification for speed strapping definition. The status of this strap is readable via the SAFE_MODE bit (bit 2, D31: F0, Offset D4h).
EE_DOUT	Reserved		System designers should include a placeholder for a pull-down resistor on EE_DOUT but do not populate the resistor.
GNT[A]#	Top-Block Swap Override	Rising Edge of PWROK	The signal has a weak internal pull-up. If the signal is sampled low, this indicates that the system is strapped to the “top-block swap” mode (ICH4 will invert A16 for all cycles targeting FWH BIOS space). The status of this strap is readable via the Top_Swap bit (bit 13, D31: F0, Offset D4h). Note that software will not be able to clear the Top-Swap bit until the system is rebooted without GNT[A]# being pulled down.
DPRSLPVR	Hub Interface Termination Scheme (correlated to HICOMP)	Rising Edge of PWROK	Low (default): Hub Interface 1.0 series or Hub Interface 1.5 parallel termination High (external pull-up to VccHI): Not supported by ICH4 See the specific platform design guide for resistor values and routing guidelines for each hub interface mode
HICOMP	Hub Interface SCHEME (HI 1.0 vs. HI 1.5)	Rising Edge of PWROK	Low (default due to weak internal pull-down): Hub Interface 1.0 buffer mode (series termination) will be selected. High (external pullup to VccHI): Hub Interface 1.5 buffer mode (parallel termination) will be selected. See the specific platform design guide for resistor values and routing guidelines for each hub interface mode.
SPKR	No Reboot	Rising Edge of PWROK	The signal has a weak internal pull-down. If the signal is sampled high, this indicates that the system is strapped to the “No Reboot” mode (ICH4 will disable the TCO Timer system reboot feature). The status of this strap is readable via the NO_REBOOT bit (bit 1, D31: F0, Offset D4h).

2.20.2 External RTC Circuitry

To reduce RTC well power consumption, the ICH4 implements an internal oscillator circuit that is sensitive to step voltage changes in VccRTC and VBIAS. Figure 2-2 shows a schematic diagram of the circuitry required to condition these voltages to ensure correct operation of the ICH4 RTC.

Figure 2-2. Example External RTC Circuit

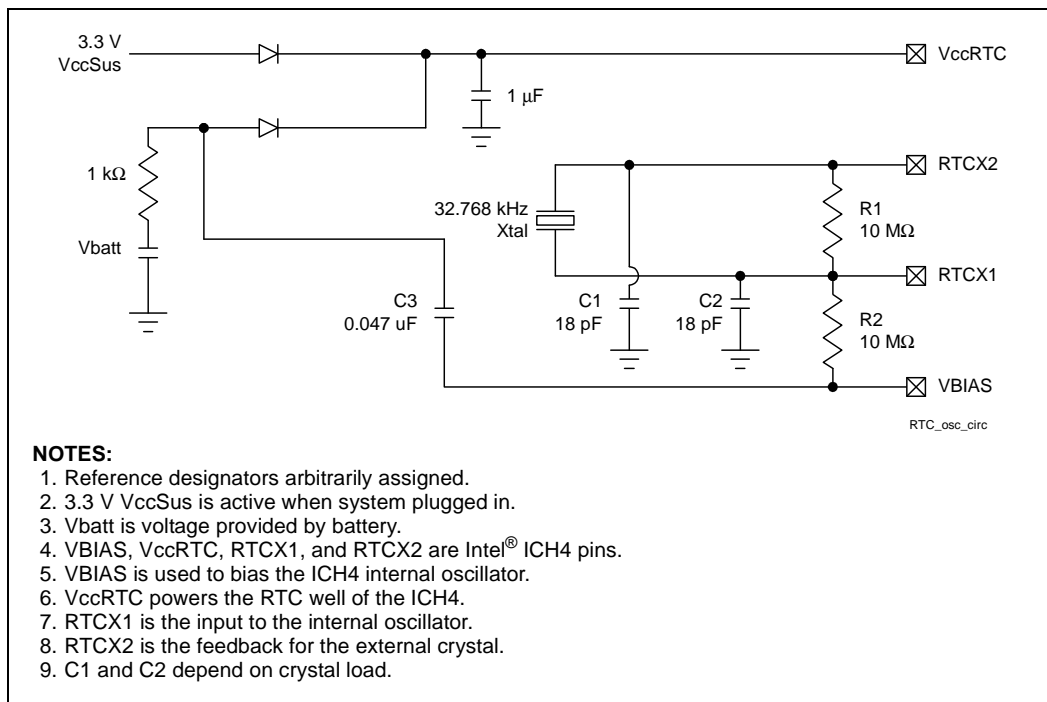

2.20.3 V5REF / Vcc3_3 Sequencing Requirements

V5REF is the reference voltage for 5 V tolerance on inputs to the ICH4. V5REF must be powered up before Vcc3_3, or after Vcc3_3 within 0.7 V. Also, V5REF must power down after Vcc3_3, or before Vcc3_3 within 0.7 V. The rule must be followed in order to ensure the safety of the ICH4. If the rule is violated, internal diodes will attempt to draw power sufficient to damage the diodes from the Vcc3_3 rail. Figure 2-3 shows a sample implementation of how to satisfy the V5REF/3.3 V sequencing rule.

This rule also applies to the standby rails, but in most platforms, the VccSus3_3 rail is derived from the VccSus5 rail and therefore, the VccSus3_3 rail will always come up after the VccSus5 rail. As a result, V5REF_Sus will always be powered up before VccSus3_3. In platforms that do not derive the VccSus3_3 rail from the VccSus5 rail, this rule must be comprehended in the platform design.

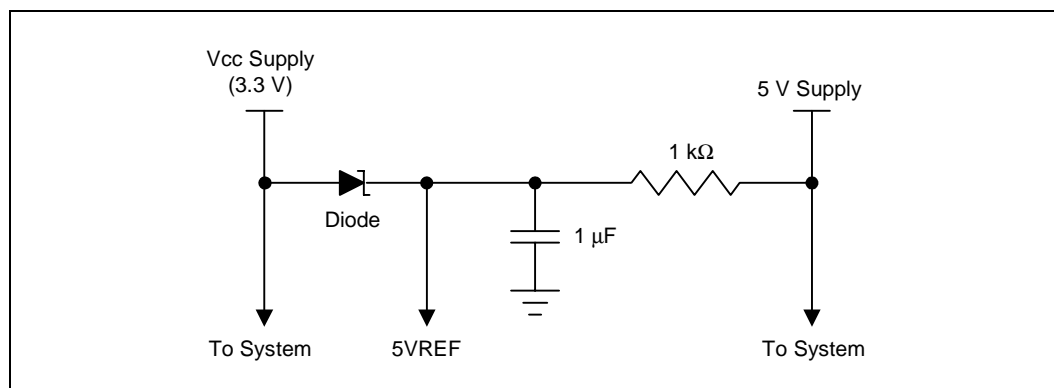
Figure 2-3. Example V5REF Sequencing Circuit

2.20.4 Test Signals

2.20.4.1 Test Mode Selection

When PWROK is active (high) for at least 76 PCI clocks, driving RTCRST# active (low) for a number of PCI clocks (33 MHz) will activate a particular test mode as specified in [Table 2-21](#).

Note: RTCRST# may be driven low any time after PCIRST is inactive. Refer to [Section 19.1](#) for a detailed description of the ICH4 test modes.

Table 2-21. Test Mode Selection

Number of PCI Clocks RTCRST# Driven Low after PWROK Active	Test Mode
<4	No Test Mode Selected
4	XOR Chain 1
5	XOR Chain 2
6	XOR Chain 3
7	XOR Chain 4
8	All "Z"
9–13	Reserved. DO NOT ATTEMPT
14	Long XOR
15–42	Reserved. DO NOT ATTEMPT
43–51	No Test Mode Selected
52	XOR Chain 6
53	XOR Chain 4 Bandgap
>53	No Test Mode Selected

This page is intentionally left blank.

Intel® ICH4 Power Planes and Pin States

3

This chapter describes the describes the system power planes for the ICH4. In addition, the ICH4 power planes and reset pin states for various signals are presented.

3.1 Power Planes

Table 3-1. Intel® ICH4 System Power Planes

Plane	Description
Main I/O (3.3 V)	Vcc3_3: Powered by the main power supply. When the system is in the S3, S4, S5, or G3 state, this plane is assumed to be shut off.
Main Logic (1.5 V)	Vcc1_5: Powered by the main power supply. When the system is in the S3, S4, S5, or G3 state, this plane is assumed to be shut off.
Resume I/O (3.3 V Standby)	VccSUS3_3: Powered by the main power supply in S0–S1 states. Powered by the trickle power supply when the system is in the S3, S4, S5, state. Assumed to be shut off only when in the G3 state (system is unplugged).
Resume Logic (1.5 V Standby)	VccSUS1_5: Powered by the main power supply in S0–S1 states. Powered by the trickle power supply when the system is in the S3, S4, S5, state. Assumed to be shut off only when in the G3 state (system is unplugged).
CPU I/F (0.8 ~ 1.75 V)	V_CPU_IO: Powered by the main power supply via CPU voltage regulator. When the system is in the S3, S4, S5, or G3 state, this plane is assumed to be shut off.
Hub Interface Logic (1.5 V or 1.8 V)	VccHI: Powered by the main power supply. Assumed to be 1.5 V when operating in Hub Interface 1.5 mode and 1.8 V when operating in Hub Interface 1.0 mode. When the system is in the S3, S4, S5, or G3 state, this plane is assumed to be shut off.
RTC	VccRTC: When other power is available (from the main supply), external diode coupling will provide power to reduce the drain on the RTC battery. Assumed to operate from 3.3 V down to 2.0 V.

3.2 Integrated Pull-Ups and Pull-Downs

Table 3-2. Integrated Pull-Up and Pull-Down Resistors

Signal	Resistor Type	Nominal Value	Notes
AC_BITCLK	pull-down	20 kΩ	1
AC_RST#	pull-down	20 kΩ	2
AC_SDIN[2:0]	pull-down	20 kΩ	2
AC_SDOOUT	pull-down	20 kΩ	2, 8
AC_SYNC	pull-down	20 kΩ	2, 8
EE_DIN	pull-up	20 kΩ	3
EE_DOUT	pull-up	20 kΩ	3
GNT[B:A]# / GNT[5]# / GPIO[17:16]	pull-up	20 kΩ	3
LAD[3:0]# / FWH[3:0]#	pull-up	20 kΩ	3
LDRQ[1:0]	pull-up	20 kΩ	3
LAN_RXD[2:0]	pull-up	10 kΩ	4
LAN_CLK	pull-down	100 kΩ	5
PME#	pull-up	20 kΩ	3
PWRBTN#	pull-up	20 kΩ	3
PDD[7] / SDD[7]	pull-down	11.5 kΩ	6
PDDREQ / SDDREQ	pull-down	11.5 kΩ	6
SPKR	pull-down	20 kΩ	2, 8
USB[5:0] [P,N]	pull-down	15 kΩ	7

NOTES:

1. Simulation data shows that these resistor values can range from 10 kΩ to 40 kΩ.
2. Simulation data shows that these resistor values can range from 9 kΩ to 50 kΩ.
3. Simulation data shows that these resistor values can range from 15 kΩ to 35 kΩ.
4. Simulation data shows that these resistor values can range from 7.5 kΩ to 16 kΩ.
5. Simulation data shows that these resistor values can range from 45 kΩ to 170 kΩ.
6. Simulation data shows that these resistor values can range from 5.7 kΩ to 28.3 kΩ.
7. Simulation data shows that these resistor values can range from 14.25 kΩ to 24.8 kΩ.
8. The pull-up or pull-down on this signal is only enabled at boot/reset for strapping function.

3.3 IDE Integrated Series Termination Resistors

Table 3-3 shows the ICH4 IDE signals that have integrated series termination resistors.

Table 3-3. IDE Series Termination Resistors

Signal	Integrated Series Termination Resistor Value
PDD[15:0], SDD[15:0], PDIOW#, SDIOW#, PDIOR#, PDIOW#, PDREQ, SDREQ, PDDACK#, SDDACK#, PIORDY, SIORDY, PDA[2:0], SDA[2:0], PDCS1#, SDCS1#, PDCS3#, SDCS3#, IRQ14, IRQ15]	approximately 33 Ω (See Note)

NOTE: Simulation data indicates that the integrated series termination resistors are a nominal 33 Ω but can range from 31 Ω to 43 Ω.

3.4 Output and I/O Signals Planes and States

Table 3-4 shows the power plane associated with the output and I/O signals, as well as the state at various times. Within the table, the following terms are used:

“High-Z”	Tri-state. ICH4 not driving the signal high or low.
“High”	ICH4 is driving the signal to a logic ‘1’
“Low”	ICH4 is driving the signal to a logic ‘0’
“Defined”	Driven to a level that is defined by the function (will be high or low)
“Undefined”	ICH4 is driving the signal, but the value is indeterminate.
“Running”	Clock is toggling or signal is transitioning because function not stopping
“Off”	The power plane is off, so ICH4 is not driving

Note that the signal levels are the same in S4 and S5.

Table 3-4. Power Plane and States for Output and I/O Signal (Sheet 1 of 4)

Signal Name	Power Plane	During PCIRST# ⁴ / RSMRST# ^{5,7}	Immediately after PCIRST# ⁴ / RSMRST# ⁵	S1	S3	S4/S5
PCI Bus						
AD[31:0]	Main I/O	High-Z	Undefined	Defined	Off	Off
C/BE#[3:0]	Main I/O	High-Z	Undefined	Defined	Off	Off
DEVSEL#	Main I/O	High-Z	High-Z	High-Z	Off	Off
FRAME#	Main I/O	High-Z	High-Z	High-Z	Off	Off
GNT[0:4]#	Main I/O	High	High	High	Off	Off
GNT[A:B]#	Main I/O	High-Z with Internal Pull-Up	High	High	Off	Off
IRDY#, TRDY#	Main I/O	High-Z	High-Z	High-Z	Off	Off
PAR	Main I/O	High-Z	Undefined	Defined	Off	Off
PCIRST#	Resume I/O	Low	High	High	Low	Low
PERR#	Main I/O	High-Z	High-Z	High-Z	Off	Off
PLOCK#	Main I/O	High-Z	High-Z	High-Z	Off	Off
STOP#	Main I/O	High-Z	High-Z	High-Z	Off	Off

Table 3-4. Power Plane and States for Output and I/O Signal (Sheet 2 of 4)

Signal Name	Power Plane	During PCIRST# ⁴ / RSMRST# ^{5,7}	Immediately after PCIRST# ⁴ / RSMRST# ⁵	S1	S3	S4/S5
LPC Interface						
LAD[3:0]	Main I/O	High	High	High	Off	Off
LFRAME#	Main I/O	High	High	High	Off	Off
LAN Connect and EEPROM Interface						
EE_CS	Resume I/O	Low	Running	Defined	Defined	Defined
EE_DOUT	Resume I/O	High	High	Defined	Defined	Defined
EE_SHCLK	Resume I/O	Low	Running	Defined	Defined	Defined
LAN_RSTSYNC	Resume I/O	High	Defined	Defined	Defined	Defined
LAN_TXD[2:0]	Resume I/O	Low	Defined	Defined	Defined	Defined
IDE Interface						
PDA[2:0], SDA[2:0]	Main I/O	Undefined	Undefined	Undefined	Off	Off
PDCS1#, PDCS3#	Main I/O	High	High	High	Off	Off
PDD[15:8], SDD[15:8], PDD[6:0], SDD[6:0]	Main I/O	High-Z	High-Z	High-Z	Off	Off
PDD[7], SDD[7]	Main I/O	Low	Low	Low	Off	Off
PDDACK#, SDDACK#	Main I/O	High	High	High	Off	Off
PDIOR#, PDIOW#	Main I/O	High	High	High	Off	Off
SDCS1#, SDCS3#	Main I/O	High	High	High	Off	Off
SDIOR#, SDIOW#	Main I/O	High	High	High	Off	Off
Interrupts						
PIRQ[A:H]#	Main I/O	High-Z	High-Z	High-Z	Off	Off
SERIRQ	Main I/O	High-Z	High-Z	High-Z	Off	Off
APICD[1:0]	Main I/O	High-Z	High-Z	High-Z	Off	Off
USB Interface						
USBP[5:0][P,N]	Resume I/O	Low	Low	Low	Low	Low
USBBIAS	Resume I/O	High-Z	High-Z	Defined	Defined	Defined

Table 3-4. Power Plane and States for Output and I/O Signal (Sheet 3 of 4)

Signal Name	Power Plane	During PCIRST# ⁴ / RSMRST# ^{5,7}	Immediately after PCIRST# ⁴ / RSMRST# ⁵	S1	S3	S4/S5
Power Management						
SLP_S3#	Resume I/O	Low	High	High	Low	Low
SLP_S4#	Resume I/O	Low	High	High	High	Low
SLP_S5#	Resume I/O	Low	High	High	High	Note 6
SUS_STAT#	Resume I/O	Low	High	High	Low	Low
SUSCLK	Resume I/O	Running				
Processor Interface						
A20M#	CPU I/O	See Note 1	High	High	Off	Off
CPUPWRGD	Main I/O	See Note 3	High-Z	High-Z	Off	Off
CPUSLP#	CPU I/O	High	High	Defined	Off	Off
IGNNE#	CPU I/O	See Note 1	High	High	Off	Off
INIT#	CPU I/O	High	High	High	Off	Off
INTR	CPU I/O	See Note 1	Low	Low	Off	Off
NMI	CPU I/O	See Note 1	Low	Low	Off	Off
SMI#	CPU I/O	High	High	High	Off	Off
STPCLK#	CPU I/O	High	High	Low	Off	Off
SMBus Interface						
SMBCLK, SMBDATA	Resume I/O	High-Z	High-Z	Defined	Defined	Defined
System Management Interface						
SMLINK[1:0]	Resume I/O	High-Z	High-Z	Defined	Defined	Defined
Miscellaneous Signals						
SPKR	Main I/O	Low with Internal Pull-Down	Low	Defined	Off	Off
AC '97 Interface						
AC_RST#	Resume I/O	Low	Low	Cold Reset Bit (High)	Low	Low
AC_SDOOUT	Main I/O	Low	Running	Low	Off	Off
AC_SYNC	Main I/O	Low	Running	Low	Off	Off

Table 3-4. Power Plane and States for Output and I/O Signal (Sheet 4 of 4)

Signal Name	Power Plane	During PCIRST# ⁴ / RSMRST# ^{5,7}	Immediately after PCIRST# ⁴ / RSMRST# ⁵	S1	S3	S4/S5
Unmuxed GPIO Signals						
GPIO[18]	Main I/O	High	See Note 2	Defined	Off	Off
GPIO[19:20]	Main I/O	High	High	Defined	Off	Off
GPIO[21]	Main I/O	High	High	Defined	Off	Off
GPIO[22]	Main I/O	High-Z	High-Z	Defined	Off	Off
GPIO[23]	Main I/O	Low	Low	Defined	Off	Off
GPIO[24]	Resume I/O	High	High	Defined	Defined	Defined
GPIO[25]	Resume I/O	High	High	Defined	Defined	Defined
GPIO[27:28]	Resume I/O	High	High	Defined	Defined	Defined
GPIO[32:43]	Main I/O	High	High	Defined	Off	Off

NOTES:

1. ICH4 sets these signals at reset for processor frequency strap.
2. GPIO[18] will toggle at a frequency of approximately 1 Hz when the ICH4 comes out of reset
3. CPUPWRGD is an open-drain output that represents a logical AND of the ICH4's VRMPWRGD and PWROK signals, and thus will be driven low by ICH4 when either VRMPWRGD or PWROK are inactive. During boot, or during a hard reset with power cycling, CPUPWRGD will be expected to transition from low to High-Z.
4. The states of main I/O signals are taken at the times During PCIRST# and Immediately after PCIRST#.
5. The states of resume I/O signals are taken at the times During RSMRST# and Immediately after RSMRST#.
6. SLP_5# is high in the S4 state and asserted low in the S5 state.
7. SUSCLK is running during PCIRST#, but is driven low during RSMRST#.

3.5 Power Planes for Input Signals

Table 3-5 shows the power plane associated with each input signal, as well as what device drives the signal at various times. Valid states include:

High

Low

Static: Will be high or low, but will not change

Driven: Will be high or low, and is allowed to change

Running: For input clocks

Table 3-5. Power Plane for Input Signals (Sheet 1 of 2)

Signal Name	Power Well	Driver During Reset	S1	S3	S5
A20GATE	Main I/O	External Microcontroller	Static	Low	Low
AC_BIT_CLK	Main I/O	AC '97 Codec	Low	Low	Low
AC_SDIN[2:0]	Resume I/O	AC '97 Codec	Low	Low	Low
APICCLK	Main I/O	Clock Generator	Running	Low	Low
CLK14	Main I/O	Clock Generator	Running	Low	Low
CLK48	Main I/O	Clock Generator	Running	Low	Low
CLK66	Main Logic	Clock Generator	Running	Low	Low
EE_DIN	Resume I/O	EEPROM Component	Driven	Driven	Driven
FERR#	CPU I/O	External Pull-Up	Static	High	High
INTRUDER#	RTC	External Switch	Driven	Driven	Driven
IRQ[15:14]	Main I/O	IDE	Static	Low	Low
LAN_CLK	Resume I/O	LAN Connect Component	Driven	Driven	Driven
LAN_RXD[2:0]	Resume I/O	LAN Connect Component	Driven	Driven	Driven
LDRQ[0]#	Main I/O	LPC Devices	High	Low	Low
LDRQ[1]#	Main I/O	LPC Devices	High	Low	Low
OC[5:0]#	Resume I/O	External Pull-Ups	Driven	Driven	Driven
PCICLK	Main I/O	Clock Generator	Running	Low	Low
PDDREQ	Main I/O	IDE Device	Static	Low	Low
PIORDY	Main I/O	IDE Device	Static	Low	Low
PME#	Resume I/O	Internal Pull-Up	Driven	Driven	Driven
PWRBTN#	Resume I/O	Internal Pull-Up	Driven	Driven	Driven
PWROK	RTC	System Power Supply	Driven	Low	Low
RCIN#	Main I/O	External Microcontroller	High	Low	Low
REQ[0:5]#	Main I/O	PCI Master	Driven	Low	Low
REQ[B:A]#	Main I/O	PC/PCI Devices	Driven	Low	Low
RI#	Resume I/O	Serial Port Buffer	Driven	Driven	Driven

Table 3-5. Power Plane for Input Signals (Sheet 2 of 2)

Signal Name	Power Well	Driver During Reset	S1	S3	S5
LAN_RST#	Resume I/O	External RC Circuit	High	High	High
RSMRST#	RTC	External RC Circuit	High	High	High
RTCST#	RTC	External RC Circuit	High	High	High
SDDREQ	Main I/O	IDE Drive	Static	Low	Low
SERR#	Main I/O	PCI Bus Peripherals	High	Low	Low
SIORDY	Main I/O	IDE Drive	Static	Low	Low
SMBALERT#	Resume I/O	External Pull-Up	Driven	Driven	Driven
SYS_RESET#	Resume I/O	External Circuit	Driven	Driven	Driven
THRM#	Main I/O	Thermal Sensor	Driven	Low	Low
THRMTRIP#	CPU I/O	External Pull-Up	Driven	High	High
USBRBIAS#	Resume I/O	External Pull-Down	Driven	Driven	Driven
VRMPWRGD	Main I/O	CPU Voltage Regulator	High	Low	Low

Intel® ICH4 and System Clock Domains4

Table 4-1 shows the system clock domains. Figure 4-1 shows the assumed connection of the various system components, including the clock generator in both desktop and mobile systems. For complete details of the system clocking solution refer to the system's clock generator component specification.

Table 4-1. Intel® ICH4 and System Clock Domains

Clock Domain	Frequency	Source	Usage
ICH4 CLK66	66 MHz	Main Clock Generator	Hub I/F, processor I/F. AGP. Shut off during S3 or below.
ICH4 PCICLK	33 MHz	Main Clock Generator	Free-running PCI Clock to ICH4. This clock remains on during S0 and S1 state, and is expected to be shut off during S3 or below .
System PCI	33 MHz	Main Clock Generator	PCI Bus, LPC I/F. These only go to external PCI and LPC devices.
ICH4 CLK48	48 MHz	Main Clock Generator	Super I/O, USB controllers. Expected to be shut off during S3 or below
ICH4 CLK14	14.31818 MHz	Main Clock Generator	Used for ACPI timer. Expected to be shut off during S3 or below
ICH4 AC_BIT_CLK	12.288 MHz	AC '97 Codec	AC-link. Generated by AC '97 Codec. Can be shut by codec in D3. Expected to be shut off during S3 or below
ICH4 APICCLK	33 MHz	Main Clock Generator	Used for ICH4-CPU interrupt messages. Runs up to 33 MHz. Expected to be shut off during S3 or below
LAN_CLK	5 to 50 MHz	LAN Connect Component	Generated by the LAN Connect component. Expected to be shut off during S3 or below

Figure 4-1. Conceptual System Clock Diagram

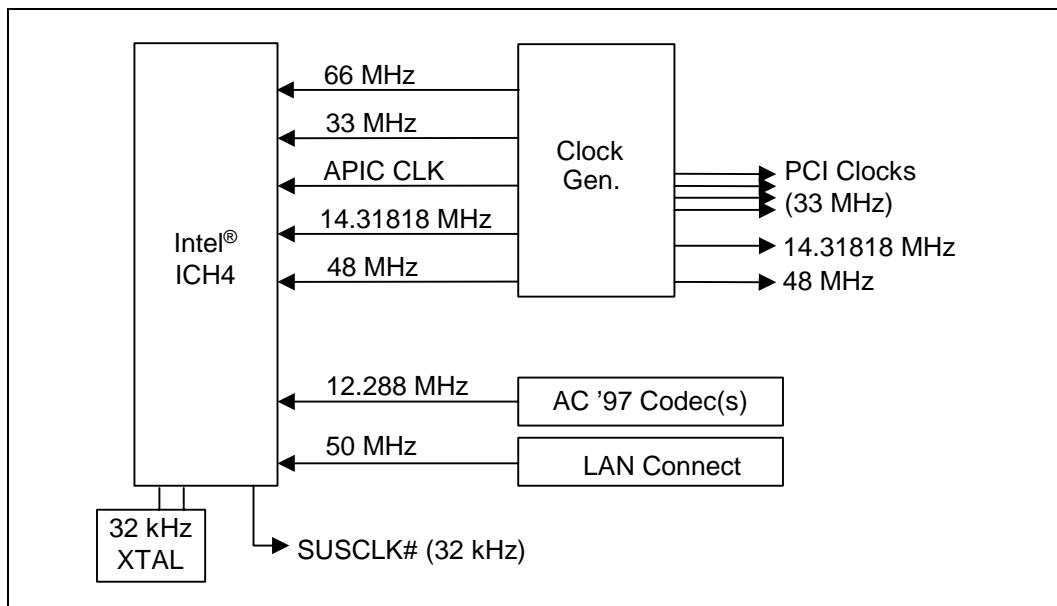

Functional Description

5

This chapter describes the functions and interfaces of the ICH4.

5.1 Hub Interface to PCI Bridge (D30:F0)

The hub interface to PCI Bridge resides in PCI Device 30, Function 0 on bus #0. This portion of the ICH4 implements the buffering and control logic between PCI and the hub interface. The arbitration for the PCI bus is handled by this PCI device. The PCI decoder in this device must decode the ranges for the hub interface. All register contents will be lost when core well power is removed.

5.1.1 PCI Bus Interface

The ICH4 PCI interface provides a 33 MHz, *PCI Local Bus Specification, Revision 2.2*-compliant implementation. All PCI signals are 5 V tolerant. The ICH4 integrates a PCI arbiter that supports up to six external PCI bus masters in addition to the internal ICH4 requests.

Note that most transactions targeted to the ICH4 will first appear on the external PCI bus before being claimed back by the ICH4. The exceptions are I/O cycles involving USB, IDE, and AC '97. These transactions will complete over the hub interface without appearing on the external PCI bus. Configuration cycles targeting USB, IDE or AC '97 will appear on the PCI bus. If the ICH4 is programmed for positive decode, the ICH4 will claim the cycles appearing on the external PCI bus in medium decode time. If the ICH4 is programmed for subtractive decode, the ICH4 will claim these cycles in subtractive time. If the ICH4 is programmed for subtractive decode, these cycles can be claimed by another positive decode agent out on PCI. This architecture enables the ability to boot off of a PCI card that positively decodes the boot cycles. In order to boot off a PCI card it is necessary to keep the ICH4 in subtractive decode mode. When booting off a PCI card, the BOOT_STS bit (bit 2, TCO2 Status Register) will be set.

Note: The ICH4's AC '97, IDE and USB controllers cannot perform peer-to-peer traffic.

Note: Poor performing PCI devices that cause long latencies (numerous retries) to processor-to-PCI Locked cycles may starve isochronous transfers between USB or AC '97 devices and memory. This will result in overrun or underrun, causing reduced quality of the isochronous data (e.g., audio).

Note: PCI configuration write cycles, initiated by the processor, with the following characteristics will be converted to a Special Cycle with the Shutdown message type.

- Device Number (AD[15:11]) = 11111
- Function Number (AD[10:8]) = 111
- Register Number (AD[7:2]) = 000000
- Data = 00h
- Bus number matches secondary bus number

Note: If the processor issues a locked cycle to a resource that is too slow (e.g., PCI), the ICH4 will not allow upstream requests to be performed until the cycle completion. This may be critical for isochronous buses which assume certain timing for their data flow (e.g., AC '97 or USB). Devices on these buses may suffer from underrun if the asynchronous traffic is too heavy. Underrun means that the same data is sent over the bus while ICH4 is not able to issue a request for the next data. Snoop cycles are not permitted while the front side bus is locked.

Note: Locked cycles are assumed to be rare. Locks by PCI targets are assumed to exist for a short duration (a few microseconds at most). If a system has a very large number of locked cycles and some that are very long, then the system will definitely experience underruns and overruns. The units most likely to have problems are the AC '97 controller and the USB controllers. Other units could get underruns/overruns, but are much less likely. The IDE controller (due to its stalling capability on the cable) should not get any underruns or overruns.

5.1.2 PCI-to-PCI Bridge Model

From a software perspective, the ICH4 contains a PCI-to-PCI bridge. This bridge connects the hub interface to the PCI bus. By using the PCI-to-PCI bridge software model, the ICH4 can have its decode ranges programmed by existing plug-and-play software such that PCI ranges do not conflict with AGP and graphics aperture ranges in the host controller.

5.1.3 IDSEL to Device Number Mapping

When addressing devices on the external PCI bus (with the PCI slots) the ICH4 will assert one address signal as an IDSEL. When accessing device 0, the ICH4 will assert AD16. When accessing Device 1, the ICH4 will assert AD17. This mapping continues all the way up to device 15 where the ICH4 asserts AD31. Note that the ICH4's internal functions (AC '97, IDE, USB, and PCI Bridge) are enumerated like they are on a separate PCI bus (the hub interface) from the external PCI bus. The integrated LAN controller is Device 8 on the ICH4's PCI bus, and hence it uses AD24 for IDSEL

5.1.4 SERR# Functionality

There are several internal and external sources that can cause SERR#. The ICH4 can be programmed to cause an NMI based on detecting that an SERR# condition has occurred. The NMI can also be routed to instead cause an SMI#. Note that the ICH4 does not drive the external PCI bus SERR# signal active onto the PCI bus. The external SERR# signal is an input into the ICH4 driven only by external PCI devices. The conceptual logic diagrams in [Figure 5-1](#) and [Figure 5-2](#) illustrate all sources of SERR#, along with their respective enable and status bits. [Figure 5-3](#) shows how the ICH4 error reporting logic is configured for NMI# generation.

Figure 5-1. Primary Device Status Register Error Reporting Logic

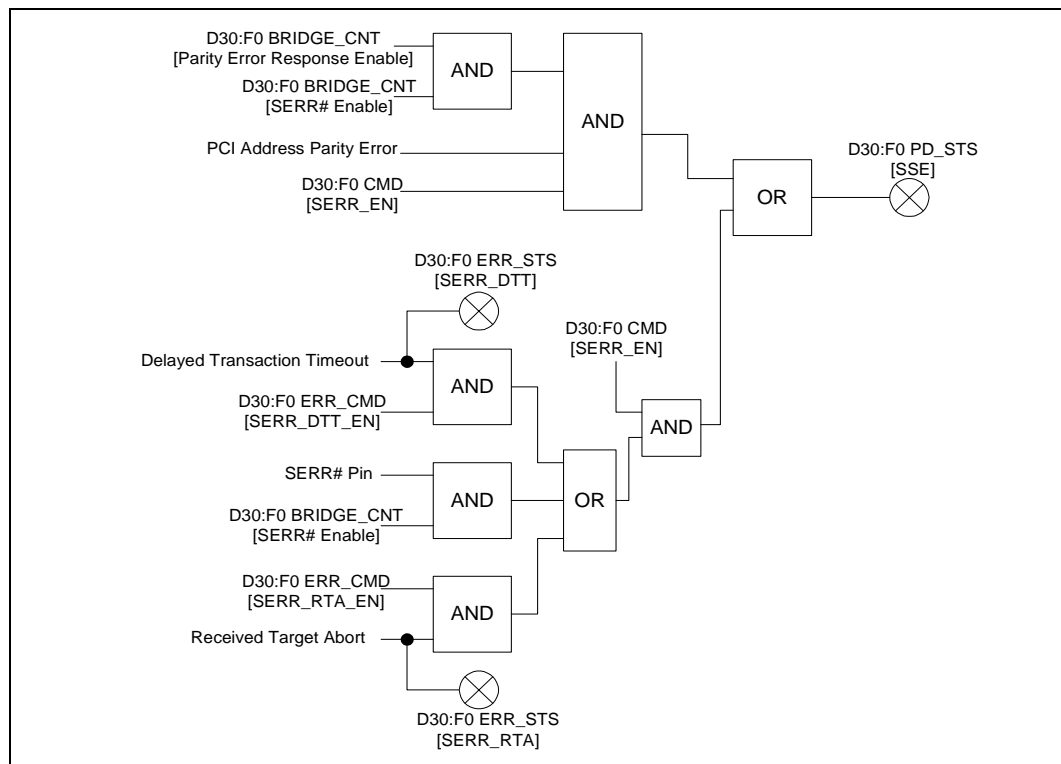

Figure 5-2. Secondary Status Register Error Reporting Logic

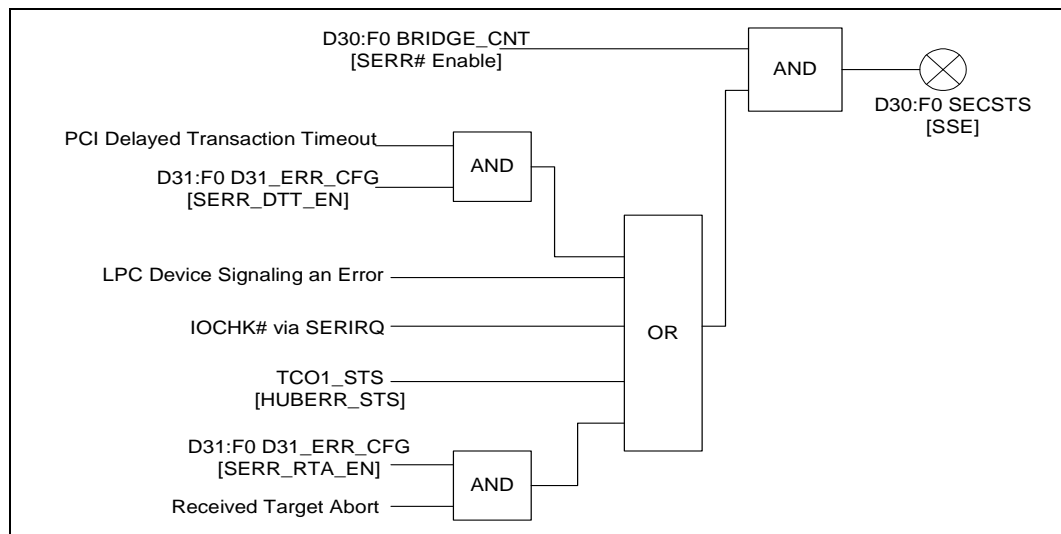
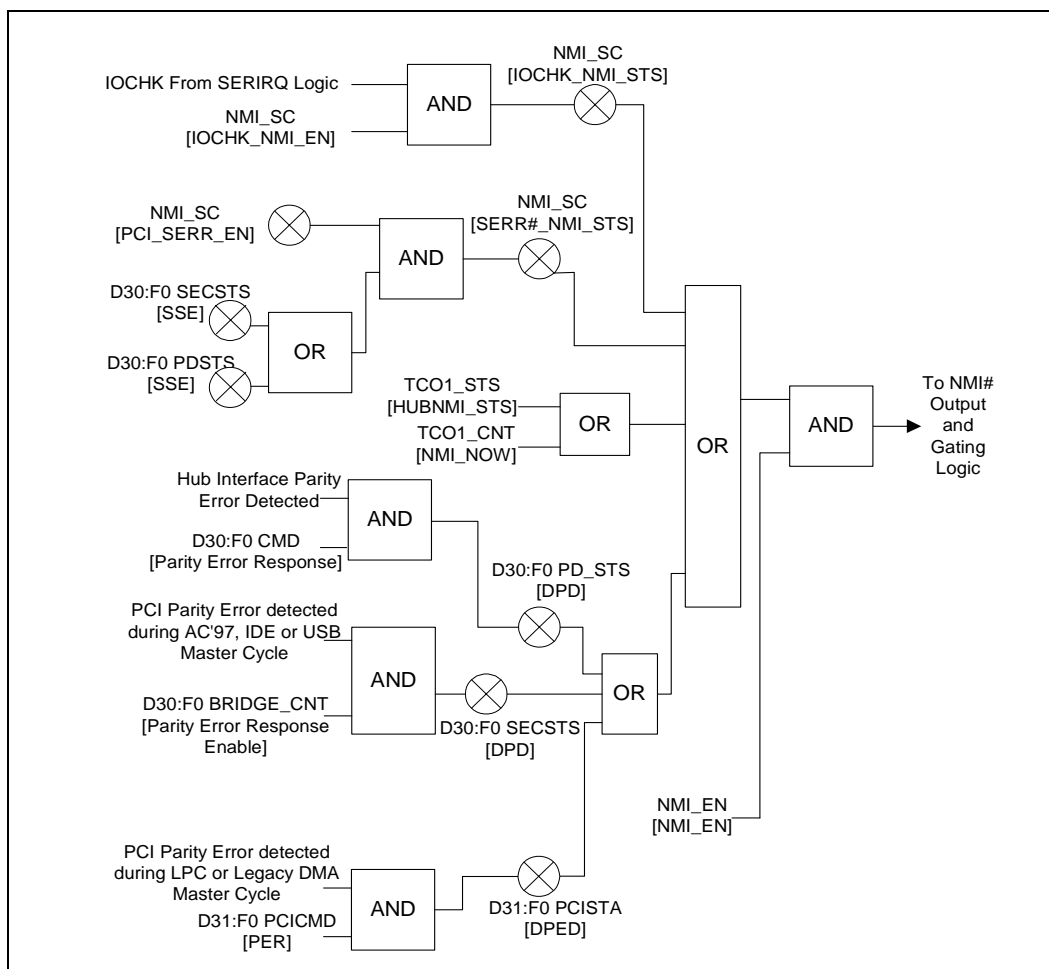

Figure 5-3. NMI# Generation Logic



5.1.5 Parity Error Detection

The ICH4 can detect and report different parity errors in the system. The ICH4 can be programmed to cause an NMI (or SMI# if NMI is routed to SMI#) based on detecting a parity error. The conceptual logic diagram in Figure 5-3 details all the parity errors that the ICH4 can detect, along with their respective enable bits, status bits, and the results.

Note: If NMIs are enabled, and parity error checking on PCI is also enabled, then parity errors will cause an NMI. Some operating systems will not attempt to recover from this NMI, since it considers the detection of a PCI error to be a catastrophic event.

5.1.6 Standard PCI Bus Configuration Mechanism

The PCI Bus defines a slot based “configuration space” that allows each device to contain up to eight functions with each function containing up to 256, 8-bit configuration registers. The PCI specification defines two bus cycles to access the PCI configuration space: Configuration Read and Configuration Write. Memory and I/O spaces are supported directly by the processor.

Configuration space is supported by a mapping mechanism implemented within the ICH4. The PCI specification defines two mechanisms to access configuration space, Mechanism #1 and Mechanism #2. The ICH4 only supports Mechanism #1.

Configuration cycles for PCI Bus #0 devices #2 through #31, and for PCI Bus numbers greater than 0 will be sent towards the ICH4 from the host controller. The ICH4 compares the non-zero Bus Number with the Secondary Bus Number and Subordinate Bus number registers of its PCI-to-PCI bridge to determine if the configuration cycle is meant for Primary PCI or a downstream PCI bus.

Note: Configuration writes to internal ICH4 USB EHCI (D29:F7) and AC '97 (D31:F5, F6) devices when disabled are illegal and may cause undefined results.

5.1.6.1 Type 0 to Type 0 Forwarding

When a Type 0 configuration cycle is received on hub interface to any function other than USB EHCI or AC '97, the ICH4 forwards these cycles to PCI and then reclaims them. The ICH4 uses address bits AD[15:13] to communicate the ICH4 device numbers in Type 0 configuration cycles. If the Type 0 cycle on hub interface specifies any device number other than 29, 30 or 31, the ICH4 will not set any address bits in the range AD[31:11] during the corresponding transaction on PCI. Table 5-1 shows the device number translation.

Table 5-1. Type 0 Configuration Cycle Device Number Translation

Device # In Hub Interface Type 0 Cycle	AD[31:11] During Address Phase of Type 0 Cycle on PCI
0 through 28	0000000000000000_00000b
29	0000000000000000_00100b
30	0000000000000000_01000b
31	0000000000000000_10000b

The ICH4 logic will generate single DWord configuration read and write cycles on the PCI bus. The ICH4 will generate a Type 0 configuration cycle for configurations to the bus number matching the PCI bus. Type 1 configuration cycles will be converted to Type 0 cycles in this case. If the cycle is targeting a device behind an external bridge, the ICH4 will run a Type 1 cycle on the PCI bus.

5.1.6.2 Type 1 to Type 0 Conversion

When the bus number for the Type 1 configuration cycle matches the PCI (Secondary) bus number, the ICH4 will convert the address as follows:

1. For device numbers 0 through 15, only one bit of the PCI address [31:16] will be set. If the device number is 0, AD[16] is set; if the device number is 1, AD[17] is set; etc.
2. The ICH4 will always drive zeros on bits AD[15:11] when converting Type 1 configurations cycles to Type 0 configuration cycles on PCI.
3. Address bits [10:1] will also be passed unchanged to PCI.
4. Address bit 0 will be changed to 0.

5.1.7 PCI Dual Address Cycle (DAC) Support

The ICH4 supports Dual Address Cycle (DAC) format on PCI for cycles from PCI initiators to main memory. This allows PCI masters to generate an address up to 44 bits. The size of the actual supported memory space will be determined by the Memory controller and the processor.

The DAC mode is only supported for PCI adapters and USB EHCI, and is not supported for any of the internal PCI masters (IDE, LAN, USB UHCI, AC '97, 8237 DMA, etc.).

When a PCI master wants to initiate a cycle with an address above 4 GB, it follows the following behavioral rules (See *PCI Local Bus Specification, Revision 2.2, Section 3.9* for more details):

1. On the first clock of the cycle (when FRAME# is first active), the peripheral uses the DAC encoding on the C/BE# signals. This unique encoding is: 1101.
2. Also during the first clock, the peripheral drives the AD[31:0] signals with the low address.
3. On the second clock, the peripheral drives AD[31:0] with the high address. The address is right justified: A[43:32] appear on AD[12:0]. The value of AD[31:13] is expected to be 0, however the ICH4 will ignore these bits. C/BE# indicate the bus command type (Memory Read, Memory Write, etc.)
4. The rest of the cycle proceeds normally.

5.2 LAN Controller (B1:D8:F0)

The ICH4's integrated LAN controller includes a 32-bit PCI controller that provides enhanced scatter-gather bus mastering capabilities and enables the LAN controller to perform high-speed data transfers over the PCI bus. Its bus master capabilities enable the component to process high level commands and perform multiple operations, which lowers processor utilization by off-loading communication tasks from the processor. Two large transmit and receive FIFOs of 3 KB each help prevent data underruns and overruns while waiting for bus accesses. This enables the integrated LAN controller to transmit data with minimum interframe spacing (IFS).

The ICH4 integrated LAN controller can operate in either full-duplex or half-duplex mode. In full-duplex mode the LAN controller adheres with the IEEE 802.3x Flow Control specification. Half duplex performance is enhanced by a proprietary collision reduction mechanism.

The integrated LAN controller also includes an interface to a serial (4-pin) EEPROM. The EEPROM provides power-on initialization for hardware and software configuration parameters.

From a software perspective, the integrated LAN controller appears to reside on the secondary side of the ICH4's virtual PCI-to-PCI Bridge (see [Section 5.1.2](#)). This is typically Bus 1, but may be assigned a different number, depending on system configuration.

The following summarizes the ICH4 LAN controller features:

- Compliance with Advanced Configuration and Power Interface and PCI Power Management standards
- Support for wake-up on interesting packets and link status change
- Support for remote power-up using Wake on LAN (WOL) technology
- Deep power-down mode support
- Support of Wired for Management (WfM) Rev 2.0
- Backward compatible software with 82557, 82558 and 82559
- TCP/UDP checksum off load capabilities
- Support for Intel's Adaptive Technology

5.2.1 LAN Controller Architectural Overview

Figure 5-4 is a high level block diagram of the ICH4 integrated LAN controller. It is divided into four main subsystems: a Parallel subsystem, a FIFO subsystem and the Carrier-Sense Multiple Access with Collision Detect (CSMA/CD) unit.

Figure 5-4. Integrated LAN Controller Block Diagram

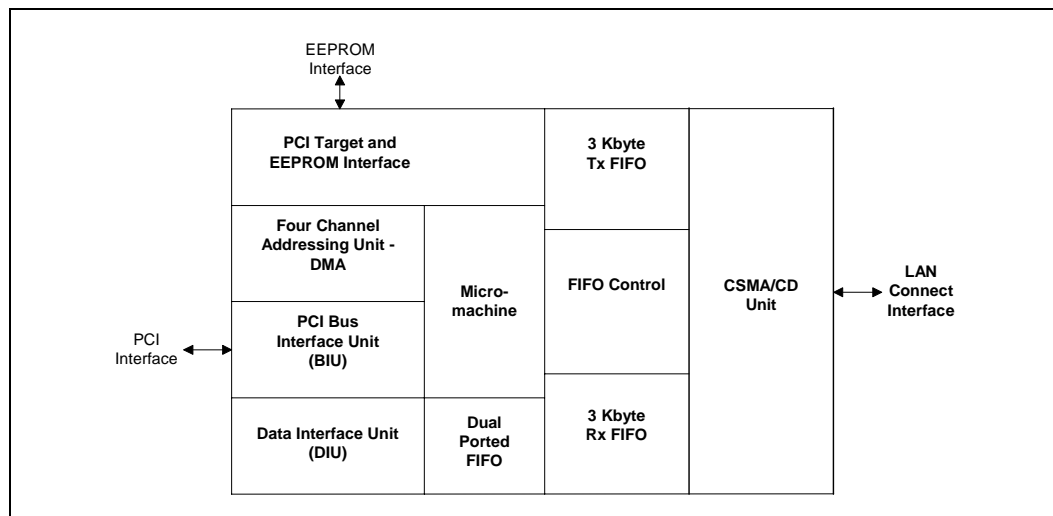

5.2.1.1 Parallel Subsystem Overview

The parallel subsystem is broken down into several functional blocks: a PCI bus master interface, a micromachine processing unit and its corresponding microcode ROM, and a PCI Target Control/EEPROM/ interface. The parallel subsystem also interfaces to the FIFO subsystem, passing data (such as transmit, receive, and configuration data) and command and status parameters between these two blocks.

The PCI bus master interface provides a complete interface to the PCI bus and is compliant with the *PCI Local Bus Specification, Revision 2.2*. The LAN controller provides 32 bits of addressing and data, as well as the complete control interface to operate on the PCI bus. As a PCI target, it follows the PCI configuration format which allows all accesses to the LAN controller to be automatically mapped into free memory and I/O space upon initialization of a PCI system. For processing of transmit and receive frames, the integrated LAN controller operates as a master on the PCI bus, initiating zero wait-state transfers for accessing these data parameters.

The LAN controller Control/Status Register Block is part of the PCI target element. The Control/Status Register block consists of the following LAN controller internal control registers: System Control Block (SCB), PORT, EEPROM Control and Management Data Interface (MDI) Control.

The micromachine is an embedded processing unit contained in the LAN controller that enables Adaptive Technology. The micromachine accesses the LAN controller's microcode ROM, working its way through the opcodes (or instructions) contained in the ROM to perform its functions. Parameters accessed from memory (e.g., pointers to data buffers) are also used by the micromachine during the processing of transmit or receive frames by the LAN controller. A typical micromachine function is to transfer a data buffer pointer field to the LAN controller's DMA unit for direct access to the data buffer. The micromachine is divided into two units, Receive Unit and Command Unit which includes transmit functions. These two units operate independently and

concurrently. Control is switched between the two units according to the microcode instruction flow. The independence of the Receive and Command units in the micromachine allows the LAN controller to execute commands and receive incoming frames simultaneously, with no real-time processor intervention.

The LAN controller contains an interface to an external serial EEPROM. The EEPROM is used to store relevant information for a LAN connection such as node address, as well as board manufacturing and configuration information. Both read and write accesses to the EEPROM are supported by the LAN controller. Information on the EEPROM interface is detailed in [Section 5.2.3](#).

5.2.1.2 FIFO Subsystem Overview

The ICH4 LAN controller FIFO subsystem consists of a 3-KB transmit FIFO and 3-KB receive FIFO. Each FIFO is unidirectional and independent of the other. The FIFO subsystem serves as the interface between the LAN controller parallel side and the serial CSMA/CD unit. It provides a temporary buffer storage area for frames as they are either being received or transmitted by the LAN controller, which improves performance:

- Transmit frames can be queued within the transmit FIFO, allowing back-to-back transmission within the minimum Interframe Spacing (IFS).
- The storage area in the FIFO allows the LAN controller to withstand long PCI bus latencies without losing incoming data or corrupting outgoing data.
- The ICH4 LAN controller's transmit FIFO threshold allows the transmit start threshold to be tuned to eliminate underruns while concurrent transmits are being performed.
- The FIFO subsection allows extended PCI zero wait-state burst accesses to or from the LAN controller for both transmit and receive frames since the transfer is to the FIFO storage area rather than directly to the serial link.
- Transmissions resulting in errors (collision detection or data underrun) are retransmitted directly from the LAN controller's FIFO, increasing performance and eliminating the need to re-access this data from the host system.
- Incoming runt receive frames (in other words, frames that are less than the legal minimum frame size) can be discarded automatically by the LAN controller without transferring this faulty data to the host system.

5.2.1.3 Serial CSMA/CD Unit Overview

The CSMA/CD unit of the ICH4 LAN controller allows it to be connected to the 82562ET/EM 10/100 Mbps Ethernet LAN Connect components. The CSMA/CD unit performs all of the functions of the 802.3 protocol (e.g., frame formatting, frame stripping, collision handling, deferral to link traffic, etc.). The CSMA/CD unit can also be placed in a full-duplex mode which allows simultaneous transmission and reception of frames.

5.2.2 LAN Controller PCI Bus Interface

As a Fast Ethernet controller, the role of the ICH4 integrated LAN controller is to access transmitted data or deposit received data. The LAN controller, as a bus master device, will initiate memory cycles via the PCI bus to fetch or deposit the required data.

To perform these actions, the LAN controller is controlled and examined by the processor via its control and status structures and registers. Some of these control and status structures reside in the LAN controller and some reside in system memory. For access to the LAN controller's Control/Status Registers (CSR), the LAN controller acts as a slave (in other words, a target device). The LAN controller serves as a slave also while the processor accesses the EEPROM.

5.2.2.1 Bus Slave Operation

The ICH4 integrated LAN controller serves as a target device in one of the following cases:

- Processor accesses to the LAN controller System Control Block (SCB) Control/Status Registers (CSR)
- Processor accesses to the EEPROM through its CSR
- Processor accesses to the LAN controller PORT address via the CSR
- Processor accesses to the MDI control register in the CSR

The size of the CSR memory space is 4 KB in the memory space and 64 bytes in the I/O space. The LAN controller treats accesses to these memory spaces differently.

Control/Status Register (CSR) Accesses

The integrated LAN controller supports zero wait-state single cycle memory or I/O mapped accesses to its CSR space. Separate BARs request 4 KB of memory space and 64 bytes of I/O space to accomplish this. Based on its needs, the software driver will use either memory or I/O mapping to access these registers. The LAN controller provides four valid Kbytes of CSR space, which include the following elements:

- System Control Block (SCB) registers
- PORT register
- EEPROM control register
- MDI control register
- Flow control registers

In the case of accessing the Control/Status Registers, the processor is the initiator and the LAN controller is the target.

Read Accesses: The processor, as the initiator, drives address lines AD[31:0], the command and byte enable lines C/BE[3:0]# and the control lines IRDY# and FRAME#. As a slave, the LAN controller controls the TRDY# signal and provides valid data on each data access. The LAN controller allows the processor to issue only one read cycle when it accesses the Control/Status Registers, generating a disconnect by asserting the STOP# signal. The processor can insert wait-states by deasserting IRDY# when it is not ready.

Write Accesses: The processor, as the initiator, drives the address lines AD[31:0], the command and byte enable lines C/BE[3:0]# and the control lines IRDY# and FRAME#. It also provides the LAN controller with valid data on each data access immediately after asserting IRDY#. The LAN controller controls the TRDY# signal and asserts it from the data access. The LAN controller allows the processor to issue only one I/O write cycle to the Control/Status Registers, generating a disconnect by asserting the STOP# signal. This is true for both memory mapped and I/O mapped accesses.

Retry Premature Accesses

The LAN controller responds with a Retry to any configuration cycle accessing the LAN controller before the completion of the automatic read of the EEPROM. The LAN controller may continue to retry any configuration accesses until the EEPROM read is complete. The LAN controller does not enforce the rule that the retried master must attempt to access the same address again in order to complete any delayed transaction. Any master access to the LAN controller after the completion of the EEPROM read will be honored.

Error Handling

Data Parity Errors: The LAN controller checks for data parity errors while it is the target of the transaction. If an error was detected, the LAN controller always sets the Detected Parity Error bit in the PCI Configuration Status register, bit 15. The LAN controller also asserts PERR#, if the Parity Error Response bit is set (PCI Configuration Command register, bit 6). The LAN controller does not attempt to terminate a cycle in which a parity error was detected. This gives the initiator the option of recovery.

Target-Disconnect: The LAN controller prematurely terminates a cycle in the following cases:

- After accesses to its CSR
- After accesses to the configuration space

System Error: The LAN controller reports parity error during the address phase using the SERR# pin. If the SERR# Enable bit in the PCI Configuration Command register or the Parity Error Response bit are not set, the LAN controller only sets the Detected Parity Error bit (PCI Configuration Status register, bit 15). If SERR# Enable and Parity Error Response bits are both set, the LAN controller sets the Signaled System Error bit (PCI Configuration Status register, bit 14) as well as the Detected Parity Error bit and asserts SERR# for one clock.

The LAN controller, when detecting system error, will claim the cycle if it was the target of the transaction and continue the transaction as if the address was correct.

Note: The LAN controller reports a system error for any error during an address phase, whether or not it is involved in the current transaction.

5.2.2.2 Bus Master Operation

As a PCI Bus Master, the ICH4 integrated LAN controller initiates memory cycles to fetch data for transmission or deposit received data and for accessing the memory resident control structures. The LAN controller performs zero wait-state burst read and write cycles to the host main memory. For bus master cycles, the LAN controller is the initiator and the host main memory (or the PCI host bridge, depending on the configuration of the system) is the target.

The processor provides the LAN controller with action commands and pointers to the data buffers that reside in host main memory. The LAN controller independently manages these structures and initiates burst memory cycles to transfer data to and from them. The LAN controller uses the Memory Read Multiple (MR Multiple) command for burst accesses to data buffers and the Memory Read Line (MR Line) command for burst accesses to control structures. For all write accesses to the control structure, the LAN controller uses the Memory Write (MW) command. For write accesses to data structure, the LAN controller may use either the Memory Write or Memory Write and Invalidate (MWI) commands.

Read Accesses: The LAN controller performs block transfers from host system memory in order to perform frame transmission on the serial link. In this case, the LAN controller initiates zero wait-state memory read burst cycles for these accesses. The length of a burst is bounded by the system and the LAN controller's internal FIFO. The length of a read burst may also be bounded by the value of the Transmit DMA Maximum Byte Count in the Configure command. The Transmit DMA Maximum Byte Count value indicates the maximum number of transmit DMA PCI cycles that will be completed after an LAN controller internal arbitration.

The LAN controller, as the initiator, drives the address lines AD[31:0], the command and byte enable lines C/BE[3:0]# and the control lines IRDY# and FRAME#. The LAN controller asserts IRDY# to support zero wait-state burst cycles. The target signals the LAN controller that valid data is ready to be read by asserting the TRDY# signal.

Write Accesses: The LAN controller performs block transfers to host system memory during frame reception. In this case, the LAN controller initiates memory write burst cycles to deposit the data, usually without wait-states. The length of a burst is bounded by the system and the LAN controller's internal FIFO threshold. The length of a write burst may also be bounded by the value of the Receive DMA Maximum Byte Count in the Configure command. The Receive DMA Maximum Byte Count value indicates the maximum number of receive DMA PCI transfers that will be completed before the LAN controller internal arbitration.

The LAN controller, as the initiator, drives the address lines AD[31:0], the command and byte enable lines C/BE[3:0]# and the control lines IRDY# and FRAME#. The LAN controller asserts IRDY# to support zero wait-state burst cycles. The LAN controller also drives valid data on AD[31:0] lines during each data phase (from the first clock and on). The target controls the length and signals completion of a data phase by deassertion and assertion of TRDY#.

Cycle Completion: The LAN controller completes (terminates) its initiated memory burst cycles in the following cases:

- **Normal Completion:** All transaction data has been transferred to or from the target device (for example, host main memory).
- **Backoff:** Latency Timer has expired and the bus grant signal (GNT#) was removed from the LAN controller by the arbiter, indicating that the LAN controller has been preempted by another bus master.
- **Transmit or Receive DMA Maximum Byte Count:** The LAN controller burst has reached the length specified in the Transmit or Receive DMA Maximum Byte Count field in the Configure command block.
- **Target Termination:** The target may request to terminate the transaction with a target-disconnect, target-retry, or target-abort. In the first two cases, the LAN controller initiates the cycle again. In the case of a target-abort, the LAN controller sets the Received Target Abort bit in the PCI Configuration Status field (PCI Configuration Status register, bit 12) and does not re-initiate the cycle.
- **Master Abort:** The target of the transaction has not responded to the address initiated by the LAN controller (in other words, DEVSEL# has not been asserted). The LAN controller simply deasserts FRAME# and IRDY# as in the case of normal completion.
- **Error Condition:** In the event of parity or any other system error detection, the LAN controller completes its current initiated transaction. Any further action taken by the LAN controller depends on the type of error and other conditions.

Memory Write and Invalidate

The LAN controller has four Direct Memory Access (DMA) channels. Of these four channels, the Receive DMA is used to deposit the large number of data bytes received from the link into system memory. The Receive DMA uses both the Memory Write (MW) and the Memory Write and Invalidate (MWI) commands. To use MWI, the LAN controller must guarantee the following:

- Minimum transfer of one cache line.
- Active byte enable bits (or BE[3:0]# are all low) during MWI access.
- The LAN controller may cross the cache line boundary only if it intends to transfer the next cache line too.

To ensure the above conditions, the LAN controller may use the MWI command only under the following conditions:

- The Cache Line Size (CLS) written in the CLS register during PCI configuration is 8 or 16 DWords.
- The accessed address is cache line aligned.
- The LAN controller has at least 8 or 16 DWords of data in its receive FIFO.
- There are at least 8 or 16 DWords of data space left in the system memory buffer.
- The MWI Enable bit in the PCI Configuration Command register, bit 4, should be set to 1b.
- The MWI Enable bit in the LAN controller Configure command should be set to 1b.

If any one of the above conditions does not hold, the LAN controller will use the MW command. If a MWI cycle has started and one of the conditions is no longer valid (for example, the data space in the memory buffer is now less than CLS), then the LAN controller terminates the MWI cycle at the end of the cache line. The next cycle will be either a MW or MWI cycle depending on the conditions listed above.

If the LAN controller started a MW cycle and reached a cache line boundary, it either continues or terminates the cycle depending on the Terminate Write on Cache Line configuration bit of the LAN controller Configure command (byte 3, bit 3). If this bit is set, the LAN controller terminates the MW cycle and attempts to start a new cycle. The new cycle is a MWI cycle if this bit is set and all of the above listed conditions are met. If the bit is not set, the LAN controller continues the MW cycle across the cache line boundary if required.

Read Align

The Read Align feature enhances the LAN controller's performance in cache line oriented systems. In these particular systems, starting a PCI transaction on a non-cache line aligned address may cause low performance.

In order to resolve this performance anomaly, the LAN controller attempts to terminate transmit DMA cycles on a cache line boundary and start the next transaction on a cache line aligned address. This feature is enabled when the Read Align Enable bit is set in the LAN controller Configure command (byte 3, bit 2).

If this bit is set, the LAN controller operates as follows:

- When the LAN controller is almost out of resources on the transmit DMA (i.e., the transmit FIFO is almost full), it attempts to terminate the read transaction on the nearest cache line boundary when possible.
- When the arbitration counter's feature is enabled (i.e., the Transmit DMA Maximum Byte Count value is set in the Configure command), the LAN controller switches to other pending DMAs on cache line boundary only.

Note:

1. This feature is not recommended for use in non-cache line oriented systems since it may cause shorter bursts and lower performance.
2. This feature should be used only when the CLS register in PCI Configuration space is set to 8 or 16.
3. The LAN controller reads all control data structures (including Receive Buffer Descriptors) from the first DWord (even if it is not required) in order to maintain cache line alignment.

Error Handling

Data Parity Errors: As an initiator, the LAN controller checks and detects data parity errors that occur during a transaction. If the Parity Error Response bit is set (PCI Configuration Command register, bit 6), the LAN controller also asserts PERR# and sets the Data Parity Detected bit (PCI Configuration Status register, bit 8). In addition, if the error was detected by the LAN controller during read cycles, it sets the Detected Parity Error bit (PCI Configuration Status register, bit 15).

5.2.2.3 PCI Power Management

Enhanced support for the power management standard, *PCI Local Bus Specification, Revision 2.2*, is provided in the ICH4 integrated LAN controller. The LAN controller supports a large set of wake-up packets and the capability to wake the system from a low power state on a link status change. The LAN controller enables the host system to be in a sleep state and remain virtually connected to the network.

After a power management event or link status change is detected, the LAN controller will wake the host system. The sections below describe these events, the LAN controller power states, and estimated power consumption at each power state.

Power States

The LAN controller contains power management registers for PCI, and implements all four power states as defined in the *Power Management Network Device Class Reference Specification, Revision 1.0*. The four states (D0 through D3) vary from maximum power consumption at D0 to the minimum power consumption at D3. PCI transactions are only allowed in the D0 state, except for host accesses to the LAN controller's PCI configuration registers. The D1 and D2 power management states enable intermediate power savings while providing the system wake-up capabilities. In the D3 cold state, the LAN controller can provide wake-up capabilities. Wake-up indications from the LAN controller are provided by the Power Management Event (PME#) signal.

- D0 Power State

As defined in the Network Device Class Reference Specification, the device is fully functional in the D0 power state. In this state, the LAN controller receives full power and should be providing full functionality. In the LAN controller the D0 state is partitioned into two substates, D0 Uninitialized (D0u) and D0 Active (D0a).

D0u is the LAN controller's initial power state following a PCI RST#. While in the D0u state, the LAN controller has PCI slave functionality to support its initialization by the host and supports Wake on LAN mode. Initialization of the CSR, Memory, or I/O Base Address Registers in the PCI Configuration space switches the LAN controller from the D0u state to the D0a state.

In the D0a state, the LAN controller provides its full functionality and consumes its nominal power. In addition, the LAN controller supports wake on link status change (see [Section 5.2.2.5](#)). While it is active, the LAN controller requires a nominal PCI clock signal (in other words, a clock frequency greater than 16 MHz) for proper operation. The LAN controller supports a dynamic standby mode. In this mode, the LAN controller is able to save almost as much power as it does in the static power-down states. The transition to or from standby is done dynamically by the LAN controller and is transparent to the software.

- D1 Power State

In order for a device to meet the D1 power state requirements, as specified in the *Advanced Configuration and Power Interface (ACPI) Specification, Revision 2.0*, it must not allow bus transmission or interrupts; however, bus reception is allowed. Therefore, device context may be lost and the LAN controller does not initiate any PCI activity. In this state, the LAN controller responds only to PCI accesses to its configuration space and system wake-up events. The LAN controller retains link integrity and monitors the link for any wake-up events (e.g., wake-up packets or link status change). Following a wake-up event, the LAN controller asserts the PME# signal.

- D2 Power State

The ACPI D2 power state is similar in functionality to the D1 power state. In addition to D1 functionality, the LAN controller can provide a lower power mode with wake-on-link status change capability. The LAN controller may enter this mode if the link is down while the LAN controller is in the D2 state. In this state, the LAN controller monitors the link for a transition from an invalid to a valid link.

The sub-10 mA state due to an invalid link can be enabled or disabled by a configuration bit in the Power Management Driver Register (PMDR). The LAN controller will consume in D2 <10 mA, regardless of the link status. It is the LAN Connect component that consumes much less power during link down, hence LAN controller in this state can consume <10 mA.

- D3 Power State

In the D3 power state, the LAN controller has the same capabilities and consumes the same amount of power as it does in the D2 state. However, it enables the PCI system to be in the B3 state. If the PCI system is in the B3 state (in other words, no PCI power is present), the LAN controller provides wake-up capabilities. If PME is disabled, the LAN controller does not provide wake-up capability or maintain link integrity. In this mode the LAN controller consumes its minimal power.

The LAN controller enables a system to be in a sub-5 Watt state (low power state) and still be virtually connected. More specifically, the LAN controller supports full wake-up capabilities while it is in the D3 cold state. The LAN controller is in the ICH4 resume well, and thus is connected to an auxiliary power source (V AUX), which enables it to provide wake-up functionality while the PCI power is off.

5.2.2.4 PCI Reset Signal

The PCIRST# signal may be activated in one of the following cases:

- During S3–S5 states
- Due to a CF9h reset

If PME# is enabled (in the PCI power management registers), PCIRST# assertion does not affect any PME# related circuits (in other words, PCI power management registers and the wake-up packet would not be affected). While PCIRST# is active, the LAN controller ignores other PCI signals. The configuration of the LAN controller registers associated with ACPI wake events is not affected by PCIRST#.

The integrated LAN controller uses the PCIRST# or the PWROK signal as an indication to ignore the PCI interface. Following the deassertion of PCIRST#, the LAN controller PCI Configuration Space, MAC configuration, and memory structure are initialized while preserving the PME# signal and its context.

5.2.2.5 Wake-Up Events

There are two types of wake-up events: “Interesting” Packets and Link Status Change. These two events are detailed below.

Note: If the Wake on LAN bit in the EEPROM is not set, wake-up events are supported only if the PME Enable bit in the Power Management Control/Status Register (PMCSR) is set. However, if the Wake on LAN bit in the EEPROM is set, and Wake on Magic Packet* or Wake on Link Status Change are enabled, the Power Management Enable bit is ignored with respect to these events. In the latter case, PME# would be asserted by these events.

"Interesting" Packet Event

In the power-down state, the LAN controller is capable of recognizing “interesting” packets. The LAN controller supports pre-defined and programmable packets that can be defined as any of the following:

- ARP Packets (with Multiple IP addresses)
- Direct Packets (with or without type qualification)
- Magic Packet
- Neighbor Discovery Multicast Address Packet (“ARP” in IPv6 environment)
- NetBIOS over TCP/IP (NBT) Query Packet (under IPv4)
- Internetwork Package Exchange* (IPX) Diagnostic Packet

This allows the LAN controller to handle various packet types. In general, the LAN controller supports programmable filtering of any packet in the first 128 bytes.

When the LAN controller is in one of the low power states, it searches for a predefined pattern in the first 128 bytes of the incoming packets. The only exception is the Magic Packet, which is scanned for the entire frame. The LAN controller will classify the incoming packets as one of the following categories:

- **No Match:** The LAN controller discards the packet and continues to process the incoming packets.
- **TCO Packet:** The LAN controller implements perfect filtering of TCO packets. After a TCO packet is processed, the LAN controller is ready for the next incoming packet. TCO packets are treated as any other wake-up packet and may assert the PME# signal if configured to do so.
- **Wake-up Packet:** The LAN controller is capable of recognizing and storing the first 128 bytes of a wake-up packet. If a wake-up packet is larger than 128 bytes, its tail is discarded by the LAN controller. After the system is fully powered-up, software has the ability to determine the cause of the wake-up event via the PMDR and dump the stored data to the host memory.

Magic Packets are an exception. The Magic Packets may cause a power management event and set an indication bit in the PMDR; however, it is not stored by the LAN controller for use by the system when it is woken up.

Link Status Change Event

The LAN controller link status indication circuit is capable of issuing a PME on a link status change from a valid link to an invalid link condition or vice versa. The LAN controller reports a PME link status event in all power states. If the Wake on LAN bit in the EEPROM is not set, the PME# signal is gated by the PME Enable bit in the PMCSR and the CSMA Configure command.

5.2.2.6 Wake on LAN* (Preboot Wake-Up)

The LAN controller enters Wake on LAN mode after reset if the Wake on LAN bit in the EEPROM is set. At this point, the LAN controller is in the D0u state.

When the LAN controller is in Wake on LAN mode:

- The LAN controller scans incoming packets for a Magic Packet and asserts the PME# signal for 52 ms when a one is detected in Wake on LAN mode.
- The Activity LED changes its functionality to indicate that the received frame passed Individual Address (IA) filtering or broadcast filtering.
- The PCI Configuration registers are accessible to the host.

The LAN controller switches from Wake on LAN mode to the D0a power state following a setup of the Memory or I/O Base Address Registers in the PCI Configuration space.

5.2.3 Serial EEPROM Interface

The serial EEPROM stores configuration data for the ICH4 integrated LAN controller and is a serial in/serial out device. The LAN controller supports a 64 register or 256 register size EEPROM and automatically detects the EEPROM's size. The EEPROM should operate at a frequency of at least 1 MHz.

All accesses, either read or write, are preceded by a command instruction to the device. The address field is six bits for a 64-register EEPROM or eight bits for a 256-register EEPROM. The end of the address field is indicated by a dummy zero bit from the EEPROM, which indicates the entire address field has been transferred to the device. An EEPROM read instruction waveform is shown in Figure 5-5.

Figure 5-5. 64-Word EEPROM Read Instruction Waveform

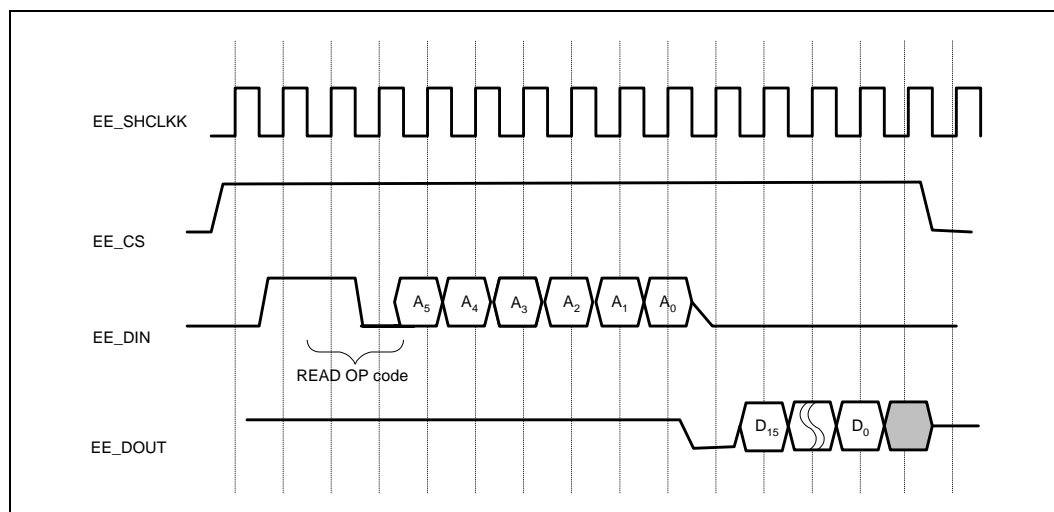

The LAN controller performs an automatic read of seven words (0h, 1h, 2h, Ah, Bh, Ch and Dh) of the EEPROM after the deassertion of Reset.

5.2.4 CSMA/CD Unit

The ICH4 integrated LAN controller CSMA/CD unit implements both the IEEE 802.3 Ethernet 10 Mbps and IEEE 802.3u Fast Ethernet 100 Mbps standards. It performs all the CSMA/CD protocol functions (e.g., transmission, reception, collision handling, etc.). The LAN controller CSMA/CD unit interfaces to the 82562ET/EM 10/100 Mbps Ethernet through the ICH4's LAN Connect interface signals.

5.2.4.1 Full Duplex

When operating in full-duplex mode, the LAN controller can transmit and receive frames simultaneously. Transmission starts regardless of the state of the internal receive path. Reception starts when the LAN Connect component detects a valid frame on its receive differential pair. The ICH4 integrated LAN controller also supports the IEEE 802.3x flow control standard, when in full-duplex mode.

The LAN controller operates in either half-duplex mode or full-duplex mode. For proper operation, both the LAN controller CSMA/CD module and the discrete LAN Connect component must be set to the same duplex mode. The CSMA duplex mode is set by the LAN controller Configure command or forced by automatically tracking the mode in the LAN Connect component. Following reset, the CSMA defaults to automatically track the LAN Connect component duplex mode.

The selection of duplex operation (full or half) and flow control is done in two levels: MAC and LAN Connect.

5.2.4.2 Flow Control

The LAN controller supports IEEE 802.3x frame-based flow control frames only in both full duplex and half duplex switched environments. The LAN controller flow control feature is not intended to be used in shared media environments.

Flow control is optional in full-duplex mode and is selected through software configuration. There are three modes of flow control that can be selected: frame-based transmit flow control, frame-based receive flow control, and none.

5.2.4.3 Address Filtering Modifications

The LAN controller can be configured to ignore one bit when checking for its Individual Address (IA) on incoming receive frames. The address bit, known as the Upper/Lower (U/L) bit, is the second least significant bit of the first byte of the IA. This bit may be used, in some cases, as a priority indication bit. When configured to do so, the LAN controller passes any frame that matches all other 47 address bits of its IA, regardless of the U/L bit value.

This configuration only affects the LAN controller specific IA and not multicast, multi-IA, or broadcast address filtering. The LAN controller does not attribute any priority to frames with this bit set, it simply passes them to memory regardless of this bit.

5.2.4.4 VLAN Support

The LAN controller supports the IEEE 802.1 standard VLAN. All VLAN flows will be implemented by software. The LAN controller supports the reception of long frames, specifically frames longer than 1518 bytes, including the CRC, if software sets the Long Receive OK bit in the Configuration command. Otherwise, “long” frames are discarded.

5.2.5 Media Management Interface

The management interface allows the processor to control the LAN Connect component via a control register in the ICH4 integrated LAN controller. This allows the software driver to place the LAN Connect in specific modes (e.g., full duplex, loopback, power down, etc.) without the need for specific hardware pins to select the desired mode. This structure allows the LAN controller to query the LAN Connect component for status of the link. This register is the MDI Control Register and resides at offset 10h in the LAN controller CSR. The MDI registers reside within the LAN Connect component, and are described in detail in the LAN Connect component’s datasheet. The processor writes commands to this register and the LAN controller reads or writes the control/status parameters to the LAN Connect component through the MDI register.

5.2.6 TCO Functionality

The ICH4 integrated LAN controller supports management communication to reduce Total Cost of Ownership (TCO). It has a System Management Bus (SMB) on which the LAN controller is a slave device. The SMB is used as an interface between the LAN controller and the integrated host controller. An EEPROM of 256 words is required to support the heartbeat command.

5.2.6.1 Receive Functionality

In the power-up state, the LAN controller transfers TCO packets to the host as any other packet. These packets include a new status indication bit in the Receive Frame Descriptor (RFD) status register and have a specific port number indicating TCO packet recognition. In the power-down state, the TCO packets are treated as wake-up packets. The ICH4 integrated LAN controller asserts the PME# signal and delivers the first 120 bytes of the packet to the host.

5.2.6.2 Transmit Functionality

The ICH4 integrated LAN controller supports the Heartbeat (HB) transmission command from the SMB interface. The send HB packet command includes a system health status issued by the integrated system controller. The LAN controller computes a matched checksum and CRC and will transmit the HB packet from its serial EEPROM. The HB packet size and structure are not limited as long as it fits within the EEPROM size. In this case, the EEPROM size is 256 words to enable the storage of the HB packet (the first 64 words are used for driver specific data).

Note: On the SMB, the send heartbeat packet command is not normally used in the D0 power state. The one exception in which it is used in the D0 state is when the system is hung. In normal operating mode, the heartbeat packets are transmitted through the ICH4 integrated LAN controller software similar to other packets.

5.3 LPC Bridge (w/ System and Management Functions) (D31:F0)

The LPC Bridge function of the ICH4 resides in PCI Device 31:Function 0. In addition to the LPC bridge function, D31:F0 contains other functional units including DMA, Interrupt controllers, Timers, Power Management, System Management, GPIO, and RTC. In this chapter, registers and functions associated with other functional units (power management, GPIO, USB, IDE, etc.) are described in their respective sections.

5.3.1 LPC Interface

The ICH4 implements an LPC interface as described in the LPC 1.0 specification. The LPC interface to the ICH4 is shown in Figure 5-6. Note that the ICH4 implements all of the signals that are shown as optional, but peripherals are not required to do so.

Figure 5-6. LPC Interface Diagram

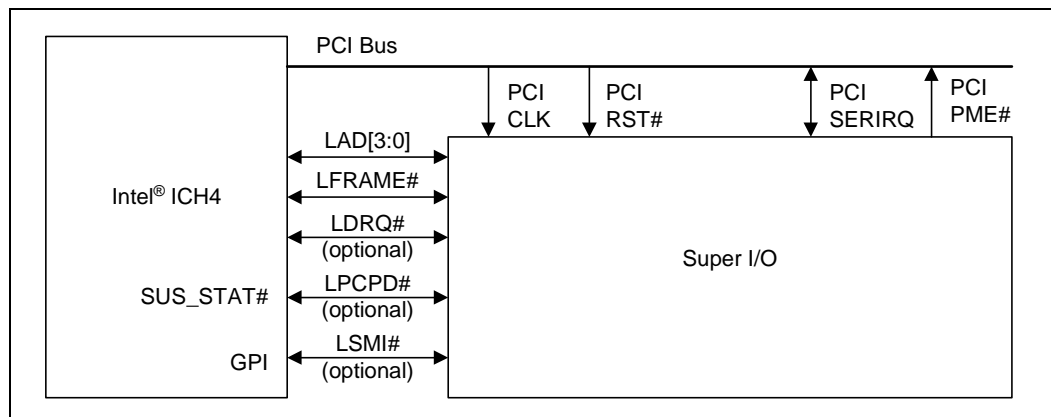

5.3.1.1 LPC Cycle Types

The ICH4 implements all of the cycle types described in the *Low Pin Count Interface Specification, Revision 1.0*. Table 5-2 shows the cycle types supported by the ICH4.

Table 5-2. LPC Cycle Types Supported

Cycle Type	Comment
Memory Read	Single: 1 byte only
Memory Write	Single: 1 byte only
I/O Read	1 byte only. Intel® ICH4 breaks up 16- and 32-bit processor cycles into multiple 8-bit transfers. (See Note 1)
I/O Write	1 byte only. ICH4 breaks up 16- and 32-bit processor cycles into multiple 8-bit transfers. (See Note 1)
DMA Read	Can be 1, or 2 bytes
DMA Write	Can be 1, or 2 bytes
Bus Master Read	Can be 1, 2, or 4 bytes. (See Note 2)
Bus Master Write	Can be 1, 2, or 4 bytes. (See Note 2)

NOTES:

- For memory cycles below 16 MB which do not target enabled FWH ranges, the ICH4 performs standard LPC memory cycles. It only attempts 8-bit transfers. If the cycle appears on PCI as a 16-bit transfer, it will appear as two consecutive 8-bit transfers on LPC. Likewise, if the cycle appears as a 32-bit transfer on PCI, it will appear as four consecutive 8-bit transfers on LPC. If the cycle is not claimed by any peripheral, it will be subsequently aborted, and the ICH4 will return a value of all ones to the processor. This is done to maintain compatibility with ISA memory cycles where pull-up resistors would keep the bus high if no device responds.
- Bus Master Read or Write cycles must be naturally aligned. For example, a 1-byte transfer can be to any address. However, the 2-byte transfer must be word aligned (i.e., with an address where A0=0). A DWord transfer must be DWord aligned (i.e., with an address where A1 and A0 are both 0).

5.3.1.2 Start Field Definition

Table 5-3. Start Field Bit Definitions

Bits[3:0] Encoding	Definition
0000	Start of cycle for a generic target
0010	Grant for bus master 0
0011	Grant for bus master 1
1111	Stop/Abort: End of a cycle for a target.

NOTE: All other encodings are RESERVED.

5.3.1.3 Cycle Type / Direction (CYCTYPE + DIR)

The ICH4 will always drive bit 0 of this field to 0. Peripherals running bus master cycles must also drive bit 0 to 0. Table 5-4 shows the valid bit encodings:

Table 5-4. Cycle Type Bit Definitions

Bits[3:2]	Bit[1]	Definition
00	0	I/O Read
00	1	I/O Write
01	0	Memory Read
01	1	Memory Write
10	0	DMA Read
10	1	DMA Write
11	x	Reserved. If a peripheral performing a bus master cycle generates this value, the Intel® ICH4 will abort the cycle.

5.3.1.4 Size

Bits[3:2] are reserved. The ICH4 always drives them to 00. Peripherals running bus master cycles are also supposed to drive 00 for bits 3:2, however, the ICH4 will ignore those bits. Bits[1:0] are encoded as shown in Table 5-5.

Table 5-5. Transfer Size Bit Definition

Bits[1:0]	Size
00	8-bit transfer (1 byte)
01	16-bit transfer (2 bytes)
10	Reserved. The Intel® ICH4 will never drive this combination. If a peripheral running a bus master cycle drives this combination, the ICH4 may abort the transfer.
11	32-bit transfer (4 bytes)

5.3.1.5 SYNC

Valid values for the SYNC field are provided in Table 5-6.

Table 5-6. SYNC Bit Definition

Bits[3:0]	Indication
0000	Ready: SYNC achieved with no error. For DMA transfers, this also indicates DMA request deassertion and no more transfers desired for that channel.
0101	Short Wait: Part indicating wait-states. For bus master cycles, the Intel® ICH4 will not use this encoding. It will instead use the Long Wait encoding (see next encoding below).
0110	Long Wait: Part indicating wait-states, and many wait-states will be added. This encoding driven by the ICH4 for bus master cycles, rather than the Short Wait (0101).
1001	Ready More (Used only by peripheral for DMA cycle): SYNC achieved with no error and more DMA transfers desired to continue after this transfer. This value is valid only on DMA transfers and is not allowed for any other type of cycle.
1010	Error: Sync achieved with error. This is generally used to replace the SERR# or IOCHK# signal on the PCI/ISA bus. It indicates that the data is to be transferred, but there is a serious error in this transfer. For DMA transfers, this not only indicates an error, but also indicates DMA request deassertion and no more transfers desired for that channel.

NOTE: All other combinations are RESERVED.

5.3.1.6 SYNC Time-Out

There are several error cases that can occur on the LPC interface. [Table 5-7](#) indicates the failing case and the ICH4 response.

Table 5-7. Intel® ICH4 Response to Sync Failures

Possible Sync Failure	Intel® ICH4 Response
Intel® ICH4 starts a Memory, I/O, or DMA cycle, but no device drives a valid SYNC after 4 consecutive clocks. This could occur if the processor tries to access an I/O location to which no device is mapped.	ICH4 aborts the cycle after the fourth clock.
ICH4 drives a Memory, I/O, or DMA cycle, and a peripheral drives more than 8 consecutive valid SYNC to insert wait-states using the Short (0101b') encoding for SYNC. This could occur if the peripheral is not operating properly.	Continues waiting
ICH4 starts a Memory, I/O, or DMA cycle, and a peripheral drives an invalid SYNC pattern. This could occur if the peripheral is not operating properly or if there is excessive noise on the LPC interface.	ICH4 aborts the cycle when the invalid Sync is recognized.

There may be other peripheral failure conditions, however these are not handled by the ICH4.

5.3.1.7 SYNC Error Indication

The SYNC protocol allows the peripheral to report an error via the LAD[3:0] = 1010b encoding. The intent of this encoding is to give peripherals a method of communicating errors to aid higher layers with more robust error recovery.

If the ICH4 was reading data from a peripheral, data will still be transferred in the next two nibbles. This data may be invalid, but it must be transferred by the peripheral. If the ICH4 was writing data to the peripheral, the data had already been transferred.

In the case of multiple byte cycles (e.g., as for memory and DMA cycles) an error SYNC terminates the cycle. Therefore, if the ICH4 is transferring 4 bytes from a device and the device returns the error SYNC in the first byte, the other three bytes will not be transferred.

Upon recognizing the SYNC field indicating an error, the ICH4 will treat this the same as IOCHK# going active on the ISA bus.

5.3.1.8 LFRAME# Usage

Start of Cycle

For Memory, I/O, and DMA cycles, the ICH4 asserts LFRAME# for 1 clock at the beginning of the cycle (Figure 5-7). During that clock, the ICH4 drives LAD[3:0] with the proper START field.

Figure 5-7. Typical Timing for LFRAME#

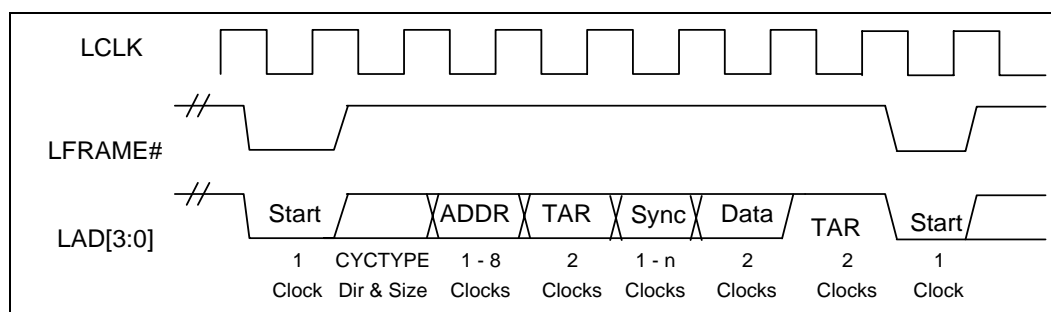

Abort Mechanism

When performing an Abort, the ICH4 drives LFRAME# active for four consecutive clocks. On the fourth clock, it drives LAD[3:0] to 1111b.

Figure 5-8. Abort Mechanism

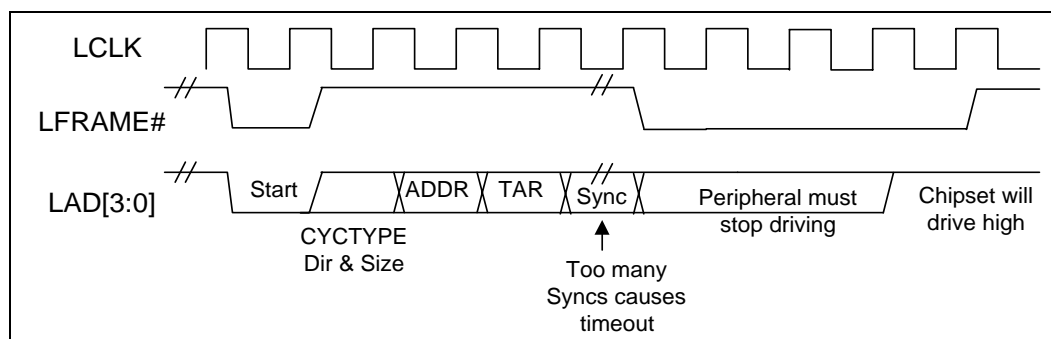

The ICH4 performs an abort for the following cases (possible failure cases):

- ICH4 starts a Memory, I/O, or DMA cycle, but no device drives a valid SYNC after four consecutive clocks.
- ICH4 starts a Memory, I/O, or DMA cycle, and the peripheral drives an invalid SYNC pattern.
- A peripheral drives an illegal address when performing bus master cycles.
- A peripheral drives an invalid value.

5.3.1.9 I/O Cycles

For I/O cycles targeting registers specified in the ICH4's decode ranges, the ICH4 performs I/O cycles as defined in the LPC specification. These will be 8-bit transfers. If the processor attempts a 16-bit or 32-bit transfer, the ICH4 breaks the cycle up into multiple 8-bit transfers to consecutive I/O addresses.

Note: If the cycle is not claimed by any peripheral (and subsequently aborted), the ICH4 returns a value of all ones (FFh) to the processor. This is to maintain compatibility with ISA I/O cycles where pull-up resistors would keep the bus high if no device responds.

5.3.1.10 Bus Master Cycles

The ICH4 supports Bus Master cycles and requests (using LDRQ#) as defined in the LPC specification. The ICH4 has two LDRQ# inputs, and thus, supports two separate bus master devices. It uses the associated START fields for Bus Master 0 (0010b) or Bus Master 1 (0011b).

Note: The ICH4 does not support LPC Bus Masters performing I/O cycles. LPC Bus Masters should only perform memory read or memory write cycles.

5.3.1.11 LPC Power Management

LPCPD# Protocol

Same timings as for SUS_STAT#. Upon driving SUS_STAT# low, LPC peripherals will drive LDRQ# low or tri-state it. ICH4 will shut off the LDRQ# input buffers. After driving SUS_STAT# active, the ICH4 drives LFRAME# low, and tri-states (or drive low) LAD[3:0].

5.3.1.12 Configuration and Intel® ICH4 Implications

LPC Interface Decoders

To allow the I/O cycles and memory mapped cycles to go to the LPC interface, the ICH4 includes several decoders. During configuration, the ICH4 must be programmed with the same decode ranges as the peripheral. The decoders are programmed via the Device 31:Function 0 configuration space.

Note: The ICH4 cannot accept PCI write cycles from PCI-to-PCI bridges or devices with similar characteristics (specifically those with a "Retry Read" feature which is enabled) to an LPC device if there is an outstanding LPC read cycle towards the same PCI device or bridge. These cycles are not part of normal system operation, but may be encountered as part of platform validation testing using custom test fixtures.

Bus Master Device Mapping and START Fields

Bus Masters must have a unique START field. In the case of the ICH4, which supports 2 LPC bus masters, it will drive 0010 for the START field for grants to bus master #0 (requested via LDRQ[0]#) and 0011 for grants to bus master #1 (requested via LDRQ[1]#). Thus, no registers are needed to configure the START fields for a particular bus master.

5.4 DMA Operation (D31:F0)

The ICH4 supports two types of DMA: LPC, and PC/PCI. DMA via LPC is similar to ISA DMA. LPC DMA and PC/PCI DMA use the ICH4's DMA controller. The DMA controller has registers that are fixed in the lower 64 KB of I/O space. The DMA controller is configured using registers in the PCI configuration space. These registers allow configuration of individual channels for use by LPC or PC/PCI DMA.

The DMA circuitry incorporates the functionality of two 82C37 DMA controllers with seven independently programmable channels (Figure 5-9). DMA controller 1 (DMA-1) corresponds to DMA channels 0–3 and DMA controller 2 (DMA-2) corresponds to channels 5–7. DMA channel 4 is used to cascade the two controllers and defaults to cascade mode in the DMA Channel Mode (DCM) Register. Channel 4 is not available for any other purpose. In addition to accepting requests from DMA slaves, the DMA controller also responds to requests that software initiates. Software may initiate a DMA service request by setting any bit in the DMA Channel Request Register to a 1.

Figure 5-9. Intel® ICH4 DMA Controller

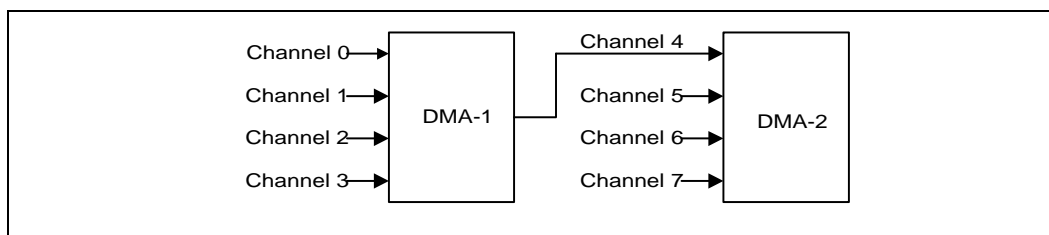

Each DMA channel is hardwired to the compatible settings for DMA device size: channels 3–0 are hardwired to 8-bit, count-by-bytes transfers, and channels 7–5 are hardwired to 16-bit, count-by-words (address shifted) transfers.

ICH4 provides 24-bit addressing in compliance with the ISA-Compatible specification. Each channel includes a 16-bit ISA-Compatible Current Register which holds the 16 least-significant bits of the 24-bit address, an ISA-Compatible Page Register which contains the eight next most significant bits of address.

The DMA controller also features refresh address generation and autoinitialization following a DMA termination.

5.4.1 Channel Priority

For priority resolution, the DMA consists of two logical channel groups: channels 0–3 and channels 4–7. Each group may be in either fixed or rotate mode, as determined by the DMA Command Register.

DMA I/O slaves normally assert their DREQ line to arbitrate for DMA service. However, a software request for DMA service can be presented through each channel's DMA Request Register. A software request is subject to the same prioritization as any hardware request. See the detailed register description for Request Register programming information in [Section 9.2](#).

5.4.1.1 Fixed Priority

The initial fixed priority structure is as follows:

High priority.....Low priority	
(0, 1, 2, 3)	(5, 6, 7)

The fixed priority ordering is 0, 1, 2, 3, 5, 6, and 7. In this scheme, channel 0 has the highest priority, and channel 7 has the lowest priority. Channels 3–0 of DMA-1 assume the priority position of channel 4 in DMA-2, thus taking priority over channels 5, 6, and 7.

5.4.1.2 Rotating Priority

Rotation allows for "fairness" in priority resolution. The priority chain rotates so that the last channel serviced is assigned the lowest priority in the channel group (0–3, 5–7).

Channels 0–3 rotate as a group of 4. They are always placed between channel 5 and channel 7 in the priority list.

Channel 5–7 rotate as part of a group of 4. That is, channels 5–7 form the first three positions in the rotation, while channel group 0–3 comprises the fourth position in the arbitration.

5.4.2 Address Compatibility Mode

When the DMA is operating, the addresses do not increment or decrement through the High and Low Page Registers. Therefore, if a 24-bit address is 01FFFFh and increments, the next address will be 010000h, not 020000h. Similarly, if a 24-bit address is 020000h and decrements, the next address will be 02FFFFh, not 01FFFFh. However, when the DMA is operating in 16-bit mode, the addresses still do not increment or decrement through the High and Low Page Registers but the page boundary is now 128 KB. Therefore, if a 24-bit address is 01FFFEh and increments, the next address will be 000000h, not 010000h. Similarly, if a 24-bit address is 020000h and decrements, the next address will be 03FFFEh, not 02FFFEh. This is compatible with the 82C37 and Page Register implementation used in the PC-AT. This mode is set after CPURST is valid.

5.4.3 Summary of DMA Transfer Sizes

Table 5-8 lists each of the DMA device transfer sizes. The column labeled “Current Byte/Word Count Register” indicates that the register contents represents either the number of bytes to transfer or the number of 16-bit words to transfer. The column labeled “Current Address Increment/Decrement” indicates the number added to or taken from the Current Address register after each DMA transfer cycle. The DMA Channel Mode Register determines if the Current Address Register will be incremented or decremented.

5.4.3.1 Address Shifting When Programmed for 16-Bit I/O Count by Words

Table 5-8. DMA Transfer Size

DMA Device Data Size And Word Count	Current Byte/Word Count Register	Current Address Increment/Decrement
8-Bit I/O, Count By Bytes	Bytes	1
16-Bit I/O, Count By Words (Address Shifted)	Words	1

The ICH4 maintains compatibility with the implementation of the DMA in the PC AT which used the 82C37. The DMA shifts the addresses for transfers to/from a 16-bit device count-by-words. Note that the least significant bit of the Low Page Register is dropped in 16-bit shifted mode. When programming the Current Address Register (when the DMA channel is in this mode), the Current Address must be programmed to an even address with the address value shifted right by one bit. The address shifting is shown in Table 5-9.

Table 5-9. Address Shifting in 16-bit I/O DMA Transfers

Output Address	8-Bit I/O Programmed Address (Ch 0-3)	16-Bit I/O Programmed Address (Ch 5-7) (Shifted)
A0 A[16:1] A[23:17]	A0 A[16:1] A[23:17]	0 A[15:0] A[23:17]

NOTE: The least significant bit of the Page Register is dropped in 16-bit shifted mode.

5.4.4 Autoinitialize

By programming a bit in the DMA Channel Mode Register, a channel may be set up as an autoinitialize channel. When a channel undergoes autoinitialization, the original values of the Current Page, Current Address, and Current Byte/Word Count registers are automatically restored from the Base Page, Address, and Byte/Word Count Registers of that channel following TC. The Base registers are loaded simultaneously with the Current registers by the microprocessor when the DMA channel is programmed and remain unchanged throughout the DMA service. The mask bit is not set when the channel is in autoinitialize. Following autoinitialize, the channel is ready to perform another DMA service, without processor intervention, as soon as a valid DREQ is detected.

5.4.5 Software Commands

There are three additional special software commands that the DMA controller can execute. The three software commands are:

- Clear Byte Pointer Flip-Flop
- Master Clear
- Clear Mask Register

They do not depend on any specific bit pattern on the data bus.

5.4.5.1 Clear Byte Pointer Flip-Flop

This command is executed prior to writing or reading new address or word count information to/from the DMA controller. This initializes the flip-flop to a known state so that subsequent accesses to register contents by the microprocessor will address upper and lower bytes in the correct sequence.

When the host processor is reading or writing DMA registers, two Byte Pointer flip-flops are used; one for channels 0–3 and one for channels 4–7. Both of these act independently. There are separate software commands for clearing each of them (0Ch for channels 0–3, 0D8h for channels 4–7).

5.4.5.2 DMA Master Clear

This software instruction has the same effect as the hardware reset. The Command, Status, Request, and Internal First/Last Flip-Flop registers are cleared and the Mask register is set. The DMA controller will enter the idle cycle.

There are two independent master clear commands; 0Dh which acts on channels 0–3, and 0DAh which acts on channels 4–7.

5.4.5.3 Clear Mask Register

This command clears the mask bits of all four channels, enabling them to accept DMA requests. I/O port 00Eh is used for channels 0–3 and I/O port 0DC h is used for channels 4–7.

5.5 PCI DMA

ICH4 provides support for the PC/PCI DMA protocol. PC/PCI DMA uses dedicated REQUEST and GRANT signals to permit PCI devices to request transfers associated with specific DMA channels. Upon receiving a request and getting control of the PCI bus, the ICH4 performs a two-cycle transfer. For example, if data is to be moved from the peripheral to main memory, the ICH4 will first read data from the peripheral and then write it to main memory. The location in main memory is the Current Address registers in the 8237.

ICH4 supports up to 2 PC/PCI REQ/GNT pairs, REQ[A:B]# and GNT[A:B]#. A 16-bit register is included in the ICH4 Function 0 configuration space at offset 90h. It is divided into seven 2-bit fields that are used to configure the seven DMA channels. Each DMA channel can be configured to one of two options:

- LPC DMA
- PC/PCI style DMA using the REQ/GNT signals

It is not possible for a particular DMA channel to be configured for more than one style of DMA; however, the seven channels can be programmed independently. For example, channel 3 could be set up for PC/PCI and channel 5 set up for LPC DMA.

The ICH4 REQ[A:B]# and GNT[A:B]# can be configured for support of a PC/PCI DMA Expansion agent. The PCI DMA Expansion agent can then provide DMA service or ISA Bus Master service using the ICH4 DMA controller. The REQ#/GNT# pair must follow the PC/PCI serial protocol described below.

5.5.1 PCI DMA Expansion Protocol

The PCI expansion agent must support the PCI expansion Channel Passing Protocol defined in [Figure 5-10](#) for both the REQ# and GNT# pins.

Figure 5-10. DMA Serial Channel Passing Protocol

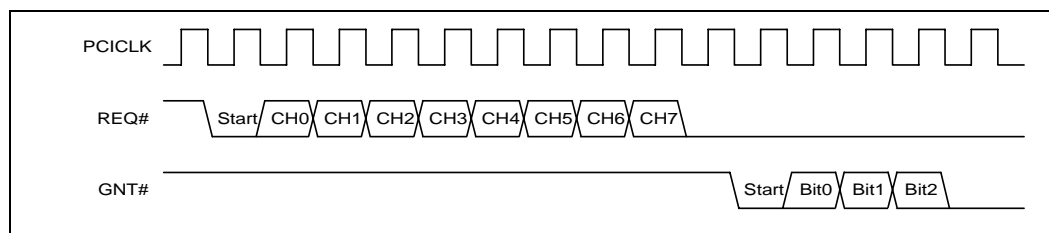

The requesting device must encode the channel request information as shown above, where CH0–CH7 are one clock active high states representing DMA channel requests 0–7.

ICH4 encodes the granted channel on the GNT# line as shown above, where the bits have the same meaning as shown in [Figure 5-10](#). For example, the sequence [start, bit 0, bit 1, bit 2]=[0,1,0,0] grants DMA channel 1 to the requesting device, and the sequence [start, bit 0, bit 1, bit 2]=[0,0,1,1] grants DMA channel 6 to the requesting device.

All PCI DMA expansion agents must use the channel passing protocol described above. They must also work as follows:

- If a PCI DMA expansion agent has more than one request active, it must resend the request serial protocol after one of the requests has been granted the bus and it has completed its transfer. The expansion device should drive its REQ# inactive for two clocks and then transmit the serial channel passing protocol again, even if there are no new requests from the PCI expansion agent to ICH4. For example: If a PCI expansion agent had active requests for DMA channel 1 and channel 5, it would pass this information to ICH4 through the expansion channel passing protocol. If after receiving GNT# (assume for CH5) and having the device finish its transfer (device stops driving request to PCI expansion agent) it would then need to re-transmit the expansion channel passing protocol to inform ICH4 that DMA channel 1 was still requesting the bus, even if that was the only request the expansion device had pending.
- If a PCI DMA expansion agent has a request go inactive before ICH4 asserts GNT#, it must resend the expansion channel passing protocol to update ICH4 with this new request information. For example: If a PCI expansion agent has DMA channel 1 and 2 requests pending it will send them serially to ICH4 using the expansion channel passing protocol. If, however, DMA channel 1 goes inactive into the expansion agent before the expansion agent receives a GNT# from ICH4, the expansion agent MUST pull its REQ# line high for ONE clock and resend the expansion channel passing information with only DMA channel 2 active. Note that ICH4 does not do anything special to catch this case because a DREQ going inactive before a DACK# is received is not allowed in the ISA DMA protocol and, therefore, does not need to work properly in this protocol either. This requirement is needed to be able to support Plug-n-Play ISA devices that toggle DREQ# lines to determine if those lines are free in the system.
- If a PCI expansion agent has sent its serial request information and receives a new DMA request before receiving GNT#, the agent must resend the serial request with the new request active. For example: If a PCI expansion agent has already passed requests for DMA channel 1 and 2 and sees DREQ 3 active before a GNT is received, the device must pull its REQ# line high for one clock and resend the expansion channel passing information with all three channels active.

The three cases above require the following functionality in the PCI DMA expansion device:

- Drive REQ# inactive for one clock to signal new request information.
- Drive REQ# inactive for two clocks to signal that a request that had been granted the bus has gone inactive.
- The REQ# and GNT# state machines must run independently and concurrently (i.e., a GNT# could be received while in the middle of sending a serial REQ# or a GNT# could be active while REQ# is inactive).

5.5.2 PCI DMA Expansion Cycles

ICH4's support of the PC/PCI DMA Protocol currently consists of four types of cycles: Memory to I/O, I/O to Memory, Verify, and ISA Master cycles. ISA Masters are supported through the use of a DMA channel that has been programmed for cascade mode.

The DMA controller does a two cycle transfer (a load followed by a store) as opposed to the ISA "fly-by" cycle for PC/PCI DMA agents. The memory portion of the cycle generates a PCI memory read or memory write bus cycle, its address representing the selected memory.

The I/O portion of the DMA cycle generates a PCI I/O cycle to one of four I/O addresses (Table 5-10). Note that these cycles must be qualified by an active GNT# signal to the requesting device.

Table 5-10. DMA Cycle vs. I/O Address

DMA Cycle Type	DMA I/O Address	PCI Cycle Type
Normal	00h	I/O Read/Write
Normal TC	04h	I/O Read/Write
Verify	0C0h	I/O Read
Verify TC	0C4h	I/O Read

5.5.3 DMA Addresses

The memory portion of the cycle generates a PCI memory read or memory write bus cycle (its address representing the selected memory). The I/O portion of the DMA cycle generates a PCI I/O cycle to one of the four I/O addresses listed in Table 5-10.

5.5.4 DMA Data Generation

The data generated by PC/PCI devices on I/O reads when they have an active GNT# is on the lower two bytes of the PCI AD bus. Table 5-11 lists the PCI pins that the data appears on for 8- and 16-bit channels. Each I/O read results in one memory write, and each memory read results in one I/O write. If the I/O device is 8 bit, the ICH4 performs an 8-bit memory write. The ICH4 does not assemble the I/O read into a DWord for writing to memory. Similarly, the ICH4 does not disassemble a DWord read from memory to the I/O device.

Table 5-11. PCI Data Bus vs. DMA I/O Port Size

PCI DMA I/O Port Size	PCI Data Bus Connection
Byte	AD[7:0]
Word	AD[15:0]

5.5.5 DMA Byte Enable Generation

The byte enables generated by the ICH4 on I/O reads and writes must correspond to the size of the I/O device. Table 5-12 defines the byte enables asserted for 8- and 16-bit DMA cycles.

Table 5-12. DMA I/O Cycle Width vs. BE[3:0]#

BE[3:0]#	Description
1110b	8-bit DMA I/O Cycle: Channels 0-3
1100b	16-bit DMA I/O Cycle: Channels 5-7

NOTE: For verify cycles the value of the Byte Enables (BEs) is a “don’t care”.

5.5.6 DMA Cycle Termination

DMA cycles are terminated when a terminal count is reached in the DMA controller and the channel is not in autoinitialize mode, or when the PC/PCI device deasserts its request. The PC/PCI device must follow explicit rules when deasserting its request, or the ICH4 may not see it in time and run an extra I/O and memory cycle.

The PC/PCI device must deassert its request 7 PCICLKs before it generates TRDY# on the I/O read or write cycle, or the ICH4 is allowed to generate another DMA cycle. For transfers to memory, this means that the memory portion of the cycle is run without an asserted PC/PCI REQ#.

5.5.7 LPC DMA

DMA on LPC is handled through the use of the LDRQ# lines from peripherals and special encodings on LAD[3:0] from the host. Single, Demand, Verify, and Increment modes are supported on the LPC interface. Channels 0–3 are 8-bit channels. Channels 5–7 are 16-bit channels. Channel 4 is reserved as a generic bus master request.

5.5.8 Asserting DMA Requests

Peripherals that need DMA service encode their requested channel number on the LDRQ# signal. To simplify the protocol, each peripheral on the LPC interface has its own dedicated LDRQ# signal (they may not be shared between two separate peripherals). The ICH4 has two LDRQ# inputs, allowing at least two devices to support DMA or bus mastering.

LDRQ# is synchronous with LCLK (PCI clock). As shown in [Figure 5-11](#) the peripheral uses the following serial encoding sequence:

- Peripheral starts the sequence by asserting LDRQ# low (start bit). LDRQ# is high during idle conditions.
- The next 3 bits contain the encoded DMA channel number (MSB first).
- The next bit (ACT) indicates whether the request for the indicated DMA channel is active or inactive. The ACT bit will be a 1 (high) to indicate if it is active and 0 (low) if it is inactive. The case where ACT is low is rare, and is only used to indicate that a previous request for that channel is being abandoned.
- After the active/inactive indication, the LDRQ# signal must go high for at least 1 clock. After that one clock, LDRQ# signal can be brought low to the next encoding sequence.

If another DMA channel also needs to request a transfer, another sequence can be sent on LDRQ#. For example, if an encoded request is sent for channel 2 and then channel 3 needs a transfer before the cycle for channel 2 is run on the interface, the peripheral can send the encoded request for channel 3. This allows multiple DMA agents behind an I/O device to request use of the LPC interface and the I/O device does not need to self-arbitrate before sending the message.

Figure 5-11. DMA Request Assertion Through LDRQ#

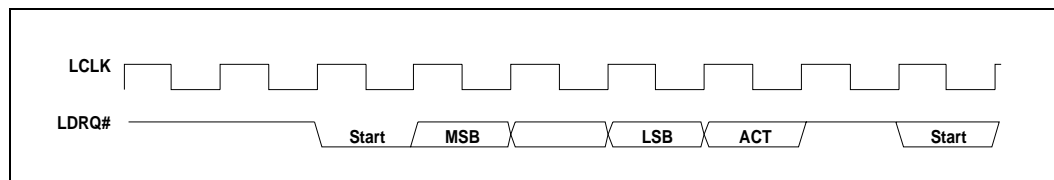

5.5.9 Abandoning DMA Requests

DMA Requests can be deasserted in two fashions: on error conditions by sending an LDRQ# message with the “ACT” bit set to 0, or normally through a SYNC field during the DMA transfer. This section describes boundary conditions where the DMA request needs to be removed prior to a data transfer.

There may be some special cases where the peripheral desires to abandon a DMA transfer. The most likely case of this occurring is due to a floppy disk controller which has overrun or underrun its FIFO, or software stopping a device prematurely.

In these cases, the peripheral wishes to stop further DMA activity. It may do so by sending an LDRQ# message with the ACT bit as 0. However, since the DMA request was seen by the ICH4, there is no guarantee that the cycle has not been granted and will shortly run on LPC. Therefore, peripherals must take into account that a DMA cycle may still occur. The peripheral can choose not to respond to this cycle, in which case the host will abort it, or it can choose to complete the cycle normally with any random data.

This method of DMA deassertion should be prevented whenever possible, to limit boundary conditions both on the ICH4 and the peripheral.

5.5.10 General Flow of DMA Transfers

Arbitration for DMA channels is performed through the 8237 within the host. Once the host has won arbitration on behalf of a DMA channel assigned to LPC, it asserts LFRAME# on the LPC interface and begins the DMA transfer. The general flow for a basic DMA transfer is as follows:

1. ICH4 starts transfer by asserting 0000b on LAD[3:0] with LFRAME# asserted.
2. ICH4 asserts “cycle type” of DMA, direction based on DMA transfer direction.
3. ICH4 asserts channel number and, if applicable, terminal count.
4. ICH4 indicates the size of the transfer: 8 or 16 bits.
5. If a DMA read...
 - The ICH4 drives the first 8 bits of data and turns the bus around.
 - The peripheral acknowledges the data with a valid SYNC.
 - If a 16-bit transfer, the process is repeated for the next 8 bits.
6. If a DMA write...
 - The ICH4 turns the bus around and waits for data.
 - The peripheral indicates data ready through SYNC and transfers the first byte.
 - If a 16-bit transfer, the peripheral indicates data ready and transfers the next byte.
7. The peripheral turns around the bus.

5.5.11 Terminal Count

Terminal count is communicated through LAD[3] on the same clock that DMA channel is communicated on LAD[2:0]. This field is the CHANNEL field. Terminal count indicates the last byte of transfer, based upon the size of the transfer.

For example, on an 88bit transfer size (SIZE field is 00b), if the TC bit is set, then this is the last byte. On a 16-bit transfer (SIZE field is 01b), if the TC bit is set, then the second byte is the last byte. The peripheral, therefore, must internalize the TC bit when the CHANNEL field is communicated, and only signal TC when the last byte of that transfer size has been transferred.

5.5.12 Verify Mode

Verify mode is supported on the LPC interface. A verify transfer to the peripheral is similar to a DMA write, where the peripheral is transferring data to main memory. The indication from the host is the same as a DMA write, so the peripheral will be driving data onto the LPC interface. However, the host will not transfer this data into main memory.

5.5.13 DMA Request Deassertion

An end of transfer is communicated to the ICH4 through a special SYNC field transmitted by the peripheral. An LPC device must not attempt to signal the end of a transfer by deasserting LDREQ#. If a DMA transfer is several bytes (e.g., a transfer from a demand mode device) the ICH4 needs to know when to deassert the DMA request based on the data currently being transferred.

The DMA agent uses a SYNC encoding on each byte of data being transferred, which indicates to the ICH4 whether this is the last byte of transfer or if more bytes are requested. To indicate the last byte of transfer, the peripheral uses a SYNC value of 0000b (ready with no error), or 1010b (ready with error). These encodings tell the ICH4 that this is the last piece of data transferred on a DMA read (ICH4 to peripheral), or the byte which follows is the last piece of data transferred on a DMA write (peripheral to ICH4).

When the ICH4 sees one of these two encodings, it ends the DMA transfer after this byte and deasserts the DMA request to the 8237. Therefore, if the ICH4 indicated a 16-bit transfer, the peripheral can end the transfer after one byte by indicating a SYNC value of 0000b or 1010b. The ICH4 will not attempt to transfer the second byte, and will deassert the DMA request internally.

If the peripheral indicates a 0000b or 1010b SYNC pattern on the last byte of the indicated size, then the ICH4 will only deassert the DMA request to the 8237 since it does not need to end the transfer.

If the peripheral wishes to keep the DMA request active, then it uses a SYNC value of 1001b (ready plus more data). This tells the 8237 that more data bytes are requested after the current byte has been transferred, so the ICH4 will keep the DMA request active to the 8237. Therefore, on an 8-bit transfer size, if the peripheral indicates a SYNC value of 1001b to the ICH4, the data will be transferred and the DMA request will remain active to the 8237. At a later time, the ICH4 will then come back with another START-CYCTYPE-CHANNEL-SIZE etc. combination to initiate another transfer to the peripheral.

The peripheral must not assume that the next START indication from the ICH4 is another grant to the peripheral if it had indicated a SYNC value of 1001b. On a single mode DMA device, the 8237 will re-arbitrate after every transfer. Only demand mode DMA devices can be guaranteed that they will receive the next START indication from the ICH4.

Note: Indicating a 0000b or 1010b encoding on the SYNC field of an odd byte of a 16-bit channel (first byte of a 16-bit transfer) is an error condition.

Note: The host will stop the transfer on the LPC bus as indicated, fill the upper byte with random data on DMA writes (peripheral to memory), and indicate to the 8237 that the DMA transfer occurred, incrementing the 8237's address and decrementing its byte count.

5.5.14 SYNC Field / LDRQ# Rules

Since DMA transfers on LPC are requested through an LDRQ# assertion message, and are ended through a SYNC field during the DMA transfer, the peripheral must obey the following rule when initiating back-to-back transfers from a DMA channel.

The peripheral must not assert another message for eight LCLKs after a deassertion is indicated through the SYNC field. This is needed to allow the 8237, which typically runs off a much slower internal clock, to see a message deasserted before it is re-asserted so that it can arbitrate to the next agent.

Under default operation, the host will only perform 8-bit transfers on 8-bit channels and 16-bit transfers on 16-bit channels.

The method by which this communication between host and peripheral through system BIOS is performed is beyond the scope of this specification. Since the LPC host and LPC peripheral are motherboard devices, no "plug-n-play" registry is required.

The peripheral must not assume that the host will be able to perform transfer sizes that are larger than the size allowed for the DMA channel, and be willing to accept a SIZE field that is smaller than what it may currently have buffered.

To that end, it is recommended that future devices which may appear on the LPC bus, which require higher bandwidth than 8-bit or 16-bit DMA allow, do so with a bus mastering interface and not rely on the 8237.

5.6 8254 Timers (D31:F0)

The ICH4 contains three counters which have fixed uses. All registers and functions associated with the 8254 timers are in the core well. The 8254 unit is clocked by a 14.31818 MHz clock.

Counter 0, System Timer

This counter functions as the system timer by controlling the state of IRQ0 and is typically programmed for Mode 3 operation. The counter produces a square wave with a period equal to the product of the counter period (838 ns) and the initial count value. The counter loads the initial count value one counter period after software writes the count value to the counter I/O address. The counter initially asserts IRQ0 and decrements the count value by two each counter period. The counter negates IRQ0 when the count value reaches 0. It then reloads the initial count value and again decrements the initial count value by two each counter period. The counter then asserts IRQ0 when the count value reaches 0, reloads the initial count value, and repeats the cycle, alternately asserting and negating IRQ0.

Counter 1, Refresh Request Signal

This counter provides the refresh request signal and is typically programmed for Mode 2 operation. The counter negates refresh request for one counter period (838 ns) during each count cycle. The initial count value is loaded one counter period after being written to the counter I/O address. The counter initially asserts refresh request, and negates it for 1 counter period when the count value reaches 1. The counter then asserts refresh request and continues counting from the initial count value.

Counter 2, Speaker Tone

This counter provides the speaker tone and is typically programmed for Mode 3 operation. The counter provides a speaker frequency equal to the counter clock frequency (1.193 MHz) divided by the initial count value. The speaker must be enabled by a write to port 061h (see NMI Status and Control ports).

5.6.1 Timer Programming

The counter/timers are programmed in the following fashion:

1. Write a control word to select a counter.
2. Write an initial count for that counter.
3. Load the least and/or most significant bytes (as required by Control Word bits 5, 4) of the 16-bit counter.
4. Repeat with other counters.

Only two conventions need to be observed when programming the counters. First, for each counter, the control word must be written before the initial count is written. Second, the initial count must follow the count format specified in the control word (least significant byte only, most significant byte only, or least significant byte and then most significant byte).

A new initial count may be written to a counter at any time without affecting the counter's programmed mode. Counting will be affected as described in the mode definitions. The new count must follow the programmed count format.

If a counter is programmed to read/write two-byte counts, the following precaution applies: A program must not transfer control between writing the first and second byte to another routine which also writes into that same counter. Otherwise, the counter will be loaded with an incorrect count.

The Control Word Register at port 43h controls the operation of all three counters. Several commands are available:

- **Control Word Command.** Specifies which counter to read or write, the operating mode, and the count format (binary or BCD).
- **Counter Latch Command.** Latches the current count so that it can be read by the system. The countdown process continues.
- **Read Back Command.** Reads the count value, programmed mode, the current state of the OUT pins, and the state of the Null Count Flag of the selected counter.

Table 5-13 lists the six operating modes for the interval counters.

Table 5-13. Counter Operating Modes

Mode	Function	Description
0	Out signal on end of count (=0)	Output is 0. When count goes to 0, output goes to 1 and stays at 1 until counter is reprogrammed.
1	Hardware retriggerable one-shot	Output is 0. When count goes to 0, output goes to 1 for one clock time.
2	Rate generator (divide by n counter)	Output is 1. Output goes to 0 for one clock time, then back to 1 and counter is reloaded.
3	Square wave output	Output is 1. Output goes to 0 when counter rolls over, and counter is reloaded. Output goes to 1 when counter rolls over, and counter is reloaded, etc.
4	Software triggered strobe	Output is 1. Output goes to 0 when count expires for one clock time.
5	Hardware triggered strobe	Output is 1. Output goes to 0 when count expires for one clock time.

5.6.2 Reading from the Interval Timer

It is often desirable to read the value of a counter without disturbing the count in progress. There are three methods for reading the counters: a simple read operation, counter Latch command, and the Read-Back command. Each is explained below.

With the simple read and counter latch command methods, the count must be read according to the programmed format; specifically, if the counter is programmed for two byte counts, two bytes must be read. The two bytes do not have to be read one right after the other. Read, write, or programming operations for other counters may be inserted between them.

5.6.2.1 Simple Read

The first method is to perform a simple read operation. The counter is selected through port 40h (counter 0), 41h (counter 1), or 42h (counter 2).

Note: Performing a direct read from the counter will not return a determinate value, because the counting process is asynchronous to read operations. However, in the case of counter 2, the count can be stopped by writing to the GATE bit in port 61h.

5.6.2.2 Counter Latch Command

The Counter Latch Command, written to port 43h, latches the count of a specific counter at the time the command is received. This command is used to ensure that the count read from the counter is accurate, particularly when reading a two-byte count. The count value is then read from each counter's Count Register as was programmed by the Control Register.

The count is held in the latch until it is read or the counter is reprogrammed. The count is then unlatched. This allows reading the contents of the counters on the fly without affecting counting in progress. Multiple Counter Latch Commands may be used to latch more than one counter. Counter Latch commands do not affect the programmed mode of the counter in any way.

If a Counter is latched and then, some time later, latched again before the count is read, the second Counter Latch command is ignored. The count read will be the count at the time the first Counter Latch command was issued.

5.6.2.3 Read Back Command

The Read Back command, written to port 43h, latches the count value, programmed mode, and current states of the OUT pin and Null Count flag of the selected counter or counters. The value of the counter and its status may then be read by I/O access to the counter address.

The Read Back command may be used to latch multiple counter outputs at one time. This single command is functionally equivalent to several counter latch commands, one for each counter latched. Each counter's latched count is held until it is read or reprogrammed. Once read, a counter is unlatched. The other counters remain latched until they are read. If multiple count Read Back commands are issued to the same counter without reading the count, all but the first are ignored.

The Read Back command may additionally be used to latch status information of selected counters. The status of a counter is accessed by a read from that counter's I/O port address. If multiple counter status latch operations are performed without reading the status, all but the first are ignored.

Both count and status of the selected counters may be latched simultaneously. This is functionally the same as issuing two consecutive, separate Read Back commands. If multiple count and/or status Read Back commands are issued to the same counters without any intervening reads, all but the first are ignored.

If both count and status of a counter are latched, the first read operation from that counter will return the latched status, regardless of which was latched first. The next one or two reads, depending on whether the counter is programmed for one or two type counts, return the latched count. Subsequent reads return unlatched count.

5.7 8259 Interrupt Controllers (PIC) (D31:F0)

The ICH4 incorporates the functionality of two 8259 interrupt controllers that provide system interrupts for the ISA compatible interrupts. These interrupts are: system timer, keyboard controller, serial ports, parallel ports, floppy disk, IDE, mouse, and DMA channels. In addition, this interrupt controller can support the PCI based interrupts, by mapping the PCI interrupt onto the compatible ISA interrupt line. Each 8259 core supports eight interrupts, numbered 0–7. Table 5-14 shows how the cores are connected.

Table 5-14. Interrupt Controller Core Connections

8259	8259 Input	Typical Interrupt Source	Connected Pin / Function
Master	0	Internal	Internal Timer / Counter 0 output
	1	Keyboard	IRQ1 via SERIRQ
	2	Internal	Slave Controller INTR output
	3	Serial Port A	IRQ3 via SERIRQ
	4	Serial Port B	IRQ4 via SERIRQ
	5	Parallel Port / Generic	IRQ5 via SERIRQ
	6	Floppy Disk	IRQ6 via SERIRQ
	7	Parallel Port / Generic	IRQ7 via SERIRQ
Slave	0	Internal Real Time Clock	Internal RTC
	1	Generic	IRQ9 via SERIRQ
	2	Generic	IRQ10 via SERIRQ
	3	Generic	IRQ11 via SERIRQ
	4	PS/2 Mouse	IRQ12 via SERIRQ
	5	Internal	State Machine output based on processor FERR# assertion.
	6	Primary IDE cable	IRQ14 from input signal (primary IDE in legacy mode only) or via SERIRQ
	7	Secondary IDE Cable	IRQ15 from input signal (secondary IDE in legacy mode only) or via SERIRQ

The ICH4 cascades the slave controller onto the master controller through master controller interrupt input 2. This means there are only 15 possible interrupts for the ICH4 PIC.

Interrupts can individually be programmed to be edge or level, except for IRQ0, IRQ2, IRQ8#, and IRQ13.

Note that previous PIIXn devices internally latched IRQ12 and IRQ1 and required a port 60h read to clear the latch. The ICH4 can be programmed to latch IRQ12 or IRQ1 (see bit 11 and bit 12 in General Control Register, D31:F0, offset D0h).

5.7.1 Interrupt Handling

5.7.1.1 Generating Interrupts

The PIC interrupt sequence involves three bits, from the IRR, ISR, and IMR, for each interrupt level. These bits are used to determine the interrupt vector returned, and status of any other pending interrupts. Table 5-15 defines the IRR, ISR and IMR.

Table 5-15. Interrupt Status Registers

Bit	Description
IRR	Interrupt Request Register. This bit is set on a low-to-high transition of the interrupt line in edge mode, and by an active high level in level mode. This bit is set whether or not the interrupt is masked. However, a masked interrupt will not generate INTR.
ISR	Interrupt Service Register. This bit is set, and the corresponding IRR bit cleared, when an interrupt acknowledge cycle is seen, and the vector returned is for that interrupt.
IMR	Interrupt Mask Register. This bit determines whether an interrupt is masked. Masked interrupts will not generate INTR.

5.7.1.2 Acknowledging Interrupts

The processor generates an interrupt acknowledge cycle which is translated by the host bridge into a PCI Interrupt Acknowledge Cycle to the ICH4. The PIC translates this command into two internal INTA# pulses expected by the 8259 cores. The PIC uses the first internal INTA# pulse to freeze the state of the interrupts for priority resolution. On the second INTA# pulse, the master or slave will send the interrupt vector to the processor with the acknowledged interrupt code. This code is based upon bits [7:3] of the corresponding ICW2 register, combined with three bits representing the interrupt within that controller.

Table 5-16. Content of Interrupt Vector Byte

Master, Slave Interrupt	Bits [7:3]	Bits [2:0]
IRQ7,15	ICW2[7:3]	111
IRQ6,14		110
IRQ5,13		101
IRQ4,12		100
IRQ3,11		011
IRQ2,10		010
IRQ1,9		001
IRQ0,8		000

5.7.1.3 Hardware/Software Interrupt Sequence

1. One or more of the Interrupt Request lines (IRQ) are raised high in edge mode, or seen high in level mode, setting the corresponding IRR bit.
2. The PIC sends INTR active to the processor if an asserted interrupt is not masked.
3. The processor acknowledges the INTR and responds with an interrupt acknowledge cycle. The cycle is translated into a PCI interrupt acknowledge cycle by the host bridge. This command is broadcast over PCI by the ICH4.
4. Upon observing its own interrupt acknowledge cycle on PCI, the ICH4 converts it into the two cycles that the internal 8259 pair can respond to. Each cycle appears as an interrupt acknowledge pulse on the internal INTA# pin of the cascaded interrupt controllers.
5. Upon receiving the first internally generated INTA# pulse, the highest priority ISR bit is set and the corresponding IRR bit is reset. On the trailing edge of the first pulse, a slave identification code is broadcast by the master to the slave on a private, internal three bit wide bus. The slave controller uses these bits to determine if it must respond with an interrupt vector during the second INTA# pulse.
6. Upon receiving the second internally generated INTA# pulse, the PIC returns the interrupt vector. If no interrupt request is present because the request was too short in duration, the PIC will return vector 7 from the master controller.
7. This completes the interrupt cycle. In AEOI mode the ISR bit is reset at the end of the second INTA# pulse. Otherwise, the ISR bit remains set until an appropriate EOI command is issued at the end of the interrupt subroutine.

5.7.2 Initialization Command Words (ICWx)

Before operation can begin, each 8259 must be initialized. In the ICH4, this is a four byte sequence. The four initialization command words are referred to by their acronyms: ICW1, ICW2, ICW3, and ICW4.

The base address for each 8259 initialization command word is a fixed location in the I/O memory space: 20h for the master controller, and A0h for the slave controller.

5.7.2.1 ICW1

An I/O write to the master or slave controller base address with data bit 4 equal to 1 is interpreted as a write to ICW1. Upon sensing this write, the ICH4 PIC expects three more byte writes to 21h for the master controller, or A1h for the slave controller, to complete the ICW sequence.

A write to ICW1 starts the initialization sequence during which the following automatically occur:

1. Following initialization, an interrupt request (IRQ) input must make a low-to-high transition to generate an interrupt.
2. The Interrupt Mask Register is cleared.
3. IRQ7 input is assigned priority 7.
4. The slave mode address is set to 7.
5. Special mask mode is cleared and Status Read is set to IRR.

5.7.2.2 ICW2

The second write in the sequence (ICW2) is programmed to provide bits [7:3] of the interrupt vector that will be released during an interrupt acknowledge. A different base is selected for each interrupt controller.

5.7.2.3 ICW3

The third write in the sequence (ICW3) has a different meaning for each controller.

- For the master controller, ICW3 is used to indicate which IRQ input line is used to cascade the slave controller. Within the ICH4, IRQ2 is used. Therefore, bit 2 of ICW3 on the master controller is set to a 1, and the other bits are set to zeros.
- For the slave controller, ICW3 is the slave identification code used during an interrupt acknowledge cycle. On interrupt acknowledge cycles, the master controller broadcasts a code to the slave controller if the cascaded interrupt won arbitration on the master controller. The slave controller compares this identification code to the value stored in its ICW3, and if it matches, the slave controller assumes responsibility for broadcasting the interrupt vector.

5.7.2.4 ICW4

The final write in the sequence, ICW4, must be programmed both controllers. At the very least, bit 0 must be set to a 1 to indicate that the controllers are operating in an Intel Architecture-based system.

5.7.3 Operation Command Words (OCW)

These command words reprogram the Interrupt controller to operate in various interrupt modes.

- OCW1 masks and unmasks interrupt lines.
- OCW2 controls the rotation of interrupt priorities when in rotating priority mode and controls the EOI function.
- OCW3 is sets up ISR/IRR reads, enables/disables the special mask mode (SMM) and enables/disables polled interrupt mode.

5.7.4 Modes of Operation

5.7.4.1 Fully Nested Mode

In this mode, interrupt requests are ordered in priority from 0 through 7, with 0 being the highest. When an interrupt is acknowledged, the highest priority request is determined and its vector placed on the bus. Additionally, the ISR for the interrupt is set. This ISR bit remains set until: the processor issues an EOI command immediately before returning from the service routine; or if in AEIO mode, on the trailing edge of the second INTA#. While the ISR bit is set, all further interrupts of the same or lower priority are inhibited, while higher levels will generate another interrupt. Interrupt priorities can be changed in the rotating priority mode.

5.7.4.2 Special Fully-Nested Mode

This mode will be used in the case of a system where cascading is used, and the priority has to be conserved within each slave. In this case, the special fully-nested mode will be programmed to the master controller. This mode is similar to the fully-nested mode with the following exceptions:

- When an interrupt request from a certain slave is in service, this slave is not locked out from the master's priority logic and further interrupt requests from higher priority interrupts within the slave will be recognized by the master and will initiate interrupts to the processor. In the normal-nested mode, a slave is masked out when its request is in service.
- When exiting the Interrupt Service routine, software has to check whether the interrupt serviced was the only one from that slave. This is done by sending a Non-Specific EOI command to the slave and then reading its ISR. If it is 0, a non-specific EOI can also be sent to the master.

5.7.4.3 Automatic Rotation Mode (Equal Priority Devices)

In some applications, there are a number of interrupting devices of equal priority. Automatic rotation mode provides for a sequential 8-way rotation. In this mode, a device receives the lowest priority after being serviced. In the worst case, a device requesting an interrupt will have to wait until each of seven other devices are serviced at most once.

There are two ways to accomplish automatic rotation using OCW2; the Rotation on Non-Specific EOI Command (R=1, SL=0, EOI=1) and the rotate in automatic EOI mode which is set by (R=1, SL=0, EOI=0).

5.7.4.4 Specific Rotation Mode (Specific Priority)

Software can change interrupt priorities by programming the bottom priority. For example, if IRQ5 is programmed as the bottom priority device, then IRQ6 will be the highest priority device. The Set Priority Command is issued in OCW2 to accomplish this, where: R=1, SL=1, and LO-L2 is the binary priority level code of the bottom priority device.

In this mode, internal status is updated by software control during OCW2. However, it is independent of the EOI command. Priority changes can be executed during an EOI command by using the Rotate on Specific EOI Command in OCW2 (R=1, SL=1, EOI=1 and LO-L2=IRQ level to receive bottom priority).

5.7.4.5 Poll Mode

Poll mode can be used to conserve space in the interrupt vector table. Multiple interrupts that can be serviced by one interrupt service routine do not need separate vectors if the service routine uses the poll command. Poll mode can also be used to expand the number of interrupts. The polling interrupt service routine can call the appropriate service routine, instead of providing the interrupt vectors in the vector table. In this mode the INTR output is not used and the microprocessor internal Interrupt Enable flip-flop is reset, disabling its interrupt input. Service to devices is achieved by software using a Poll command.

The Poll command is issued by setting P=1 in OCW3. The PIC treats its next I/O read as an interrupt acknowledge, sets the appropriate ISR bit if there is a request, and reads the priority level. Interrupts are frozen from the OCW3 write to the I/O read. The byte returned during the I/O read will contain a 1 in bit 7 if there is an interrupt, and the binary code of the highest priority level in bits 2:0.

5.7.4.6 Cascade Mode

The PIC in the ICH4 has one master 8259 and one slave 8259 cascaded onto the master through IRQ2. This configuration can handle up to 15 separate priority levels. The master controls the slaves through a three bit internal bus. In the ICH4, when the master drives 010b on this bus, the slave controller takes responsibility for returning the interrupt vector. An EOI command must be issued twice: once for the master and once for the slave.

5.7.4.7 Edge and Level Triggered Mode

In ISA systems this mode is programmed using bit 3 in ICW1, which sets level or edge for the entire controller. In the ICH4, this bit is disabled and a new register for edge and level triggered mode selection, per interrupt input, is included. This is the Edge/Level control Registers ELCR1 and ELCR2.

If an ELCR bit is 0, an interrupt request will be recognized by a low-to-high transition on the corresponding IRQ input. The IRQ input can remain high without generating another interrupt. If an ELCR bit is 1, an interrupt request will be recognized by a high level on the corresponding IRQ input and there is no need for an edge detection. The interrupt request must be removed before the EOI command is issued to prevent a second interrupt from occurring.

In both the edge and level triggered modes, the IRQ inputs must remain active until after the falling edge of the first internal INTA#. If the IRQ input goes inactive before this time, a default IRQ7 vector will be returned.

5.7.4.8 End of Interrupt Operations

An EOI can occur in one of two fashions: by a command word write issued to the PIC before returning from a service routine, the EOI command; or automatically when AEOI bit in ICW4 is set to 1.

5.7.4.9 Normal End of Interrupt

In Normal EOI, software writes an EOI command before leaving the interrupt service routine to mark the interrupt as completed. There are two forms of EOI commands: Specific and Non-Specific. When a Non-Specific EOI command is issued, the PIC will clear the highest ISR bit of those that are set to 1. Non-Specific EOI is the normal mode of operation of the PIC within the ICH4, as the interrupt being serviced currently is the interrupt entered with the interrupt acknowledge. When the PIC is operated in modes which preserve the fully nested structure, software can determine which ISR bit to clear by issuing a Specific EOI. An ISR bit that is masked will not be cleared by a Non-Specific EOI if the PIC is in the special mask mode. An EOI command must be issued for both the master and slave controller.

5.7.4.10 Automatic End of Interrupt Mode

In this mode, the PIC will automatically perform a Non-Specific EOI operation at the trailing edge of the last interrupt acknowledge pulse. From a system standpoint, this mode should be used only when a nested multi-level interrupt structure is not required within a single PIC. The AEOI mode can only be used in the master controller and not the slave controller.

5.7.5 Masking Interrupts

5.7.5.1 Masking on an Individual Interrupt Request

Each interrupt request can be masked individually by the Interrupt Mask Register (IMR). This register is programmed through OCW1. Each bit in the IMR masks one interrupt channel. Masking IRQ2 on the master controller will mask all requests for service from the slave controller.

5.7.5.2 Special Mask Mode

Some applications may require an interrupt service routine to dynamically alter the system priority structure during its execution under software control. For example, the routine may wish to inhibit lower priority requests for a portion of its execution but enable some of them for another portion.

The special mask mode enables all interrupts not masked by a bit set in the Mask Register. Normally, when an interrupt service routine acknowledges an interrupt without issuing an EOI to clear the ISR bit, the interrupt controller inhibits all lower priority requests. In the special mask mode, any interrupts may be selectively enabled by loading the Mask Register with the appropriate pattern. The special mask mode is set by OCW3 where: SSMM=1, SMM=1, and cleared where SSMM=1, SMM=0.

5.7.6 Steering PCI Interrupts

The ICH4 can be programmed to allow PIRQA#-PIRQH# to be internally routed to interrupts 3-7, 9-12, 14 or 15. The assignment is programmable through the PIRQx Route Control registers, located at 60-63h and 68-6Bh in function 0. One or more PIRQx# lines can be routed to the same IRQx input. If interrupt steering is not required, the Route Registers can be programmed to disable steering.

The PIRQx# lines are defined as active low, level sensitive to allow multiple interrupts on a PCI Board to share a single line across the connector. When a PIRQx# is routed to specified IRQ line, software must change the IRQ's corresponding ELCR bit to level sensitive mode. The ICH4 will internally invert the PIRQx# line to send an active high level to the PIC. When a PCI interrupt is routed onto the PIC, the selected IRQ can no longer be used by an ISA device (through SERIRQ). However, active low non-ISA interrupts can share their interrupt with PCI interrupts.

Internal sources of the PIRQs, including SCI and TCO interrupts, cause the external PIRQ to be asserted. The ICH4 receives the PIRQ input, like all of the other external sources, and routes it accordingly.

5.8 Advanced Interrupt Controller (APIC) (D31:F0)

In addition to the standard ISA-compatible Programmable Interrupt Controller (PIC) described in [Section 5.7](#), the ICH4 incorporates the Advanced Programmable Interrupt Controller (APIC). While the standard interrupt controller is intended for use in a uni-processor system, APIC can be used in either a uni-processor or multi-processor system.

5.8.1 Interrupt Handling

The I/O APIC handles interrupts very differently than the 8259. Briefly, these differences are:

- **Method of Interrupt Transmission.** The I/O APIC transmits interrupts through a three wire bus, and interrupts are handled without the need for the processor to run an interrupt acknowledge cycle.
- **Interrupt Priority.** The priority of interrupts in the I/O APIC is independent of the interrupt number. For example, interrupt 10 can be given a higher priority than interrupt 3.
- **More Interrupts.** The I/O APIC in the ICH4 supports a total of 24 interrupts.
- **Multiple Interrupt Controllers.** The I/O APIC interrupt transmission protocol has an arbitration phase, which allows for multiple I/O APICs in the system with their own interrupt vectors. The ICH4 I/O APIC must arbitrate for the APIC bus before transmitting its interrupt message.

5.8.2 Interrupt Mapping

The I/O APIC within the ICH4 supports 24 APIC interrupts. Each interrupt has its own unique vector assigned by software. The interrupt vectors are mapped as follows, and match “Config 6” of the Multi-Processor Specification.

Table 5-17. APIC Interrupt Mapping (Sheet 1 of 2)

IRQ #	Via SERIRQ	Direct from pin	Via PCI message	Internal Modules
0	No	No	No	Cascade from 8259 #1
1	Yes	No	Yes	
2	No	No	No	8254 Counter 0
3	Yes	No	Yes	
4	Yes	No	Yes	
5	Yes	No	Yes	
6	Yes	No	Yes	
7	Yes	No	Yes	
8	No	No	No	RTC
9	Yes	No	Yes	Option for SCI, TCO
10	Yes	No	Yes	Option for SCI, TCO
11	Yes	No	Yes	Option for SCI, TCO
12	Yes	No	Yes	

Table 5-17. APIC Interrupt Mapping (Sheet 2 of 2)

IRQ #	Via SERIRQ	Direct from pin	Via PCI message	Internal Modules
13	No	No	No	FERR# logic
14	Yes	Yes ¹	Yes	
15	Yes	Yes ¹	Yes	
16	PIRQ[A]#	PIRQ[A]#	No	USB UHCI controller #1
17	PIRQ[B]#	PIRQ[B]#	No	AC '97 Audio, Modem, option for SMBus
18	PIRQ[C]#	PIRQ[C]#	No	USB UHCI controller #3, Native IDE
19	PIRQ[D]#	PIRQ[D]#	No	USB UHCI controller #2
20	N/A	PIRQ[E]#	Yes	LAN, option for SCI, TCO
21	N/A	PIRQ[F]#	Yes	Option for SCI, TCO
22	N/A	PIRQ[G]#	Yes	Option for SCI, TCO
23	N/A	PIRQ[H]#	Yes	USB EHCI controller, option for SCI, TCO

NOTES:

1. IRQ 14 and 15 can only be driven directly from the pins when in legacy IDE mode.
2. When programming the polarity of internal interrupt sources on the APIC, interrupts 0 through 15 receive active-high internal interrupt sources, while interrupts 16 through 23 receive active-low internal interrupt sources.

5.8.3 APIC Bus Functional Description

5.8.3.1 Physical Characteristics of APIC

The APIC bus is a 3-wire synchronous bus connecting all I/O and local APICs. Two of these wires are used for data transmission, and one wire is a clock. For bus arbitration, the APIC uses only one of the data wires. The bus is logically a wire-OR and electrically an open-drain connection providing for both bus use arbitration and arbitration for lowest priority. The APIC bus speed can run from 16.67 MHz to 33 MHz.

5.8.3.2 APIC Bus Arbitration

The I/O APIC uses one wire arbitration to win bus ownership. A rotating priority scheme is used for APIC bus arbitration. The winner of the arbitration becomes the lowest priority agent and assumes an arbitration ID of 0. All other agents, except the agent whose arbitration ID is 15, increment their Arbitration IDs by one. The agent whose ID was 15 will take the winner's arbitration ID and will increment it by one. Arbitration IDs are changed only for messages that are transmitted successfully (except for the Low Priority messages). A message is transmitted successfully if no CS error or acceptance error was reported for that message.

An APIC agent can use two different priority schemes: Normal or EOI. EOI has the highest priority. EOI priority is used to send EOI messages for level interrupts from a local APIC to an I/O APIC. When an agent requests the bus with EOI priority, all other agents requesting the bus with normal priorities will back off.

When ICH4 detects a bus idle condition on the APIC Bus, and it has an interrupt to send over the APIC bus, it drives a start cycle to begin arbitration by driving bit 0 to a 0 on an APICCLK rising edge. It then samples bit 1. If Bit 1 was a 0, then a local APIC started arbitration for an EOI message on the same clock edge that the ICH4 started arbitration. The ICH4 has, thus, lost arbitration and will stop driving the APIC bus.

If the ICH4 did not see an EOI message start, it will start transferring its arbitration ID, located in bits [27:24] of its Arbitration ID register (ARBID). Starting in Cycle 2, through Cycle 5, it will tri-state bit 0, and drive bit 1 to a 0 if ARBID[27] is a 1. If ARBID[27] is a 0, it will also tri-state bit 1. At the end of each cycle, the ICH4 will sample the state of Bit 1 on the APIC bus. If the ICH4 did not drive Bit 1 (ARBID[27] = 0), and it samples a 0, then another APIC agent started arbitration for the APIC bus at the same time as the ICH4, and it has higher priority. The ICH4 will stop driving the APIC bus. [Table 5-18](#) describes the arbitration cycles.

Table 5-18. Arbitration Cycles

Cycle	Bit 1	Bit 0	Comment
1	EOI	0	Bit 1 = 1: Normal, Bit 1 = 0: EOI
2	NOT (ARBID[27])	1	Arbitration ID. If ICH4 samples a different value than it sent, it lost arbitration.
3	NOT (ARBID[26])	1	
4	NOT (ARBID[25])	1	
5	NOT (ARBID[24])	1	

5.8.3.3 Bus Message Formats

After bus arbitration, the winner is granted exclusive use of the bus and will drive its message. APIC messages come in four formats, determined by the Delivery Mode bits. These four messages are of different length, and are known by all APICs on the bus through the transmission of the Delivery Mode bits.

Table 5-19. APIC Message Formats

Message	# of Cycles	Delivery Mode Bits	Comments
EOI	14	xxx	End of Interrupt transmission from Local APIC to I/O APIC on Level interrupts. EOI is known by the EOI bit at the start of arbitration.
Short	21	001, 010, 100, 101, 111	I/O APIC delivery on Fixed, NMI, SMI, Reset, ExtINT, and Lowest Priority with focus processor messages.
Lowest Priority	33	001	Transmission of Lowest Priority interrupts when the status field indicates that the processor does not have focus.
Remote Read	39	011	Message from one Local APIC to another to read registers.

EOI Message for Level Triggered Interrupts

EOI messages are used by local APICs to send an EOI cycle occurring for a level-triggered interrupt to an I/O APIC. This message is needed so that the I/O APIC can differentiate between a new interrupt on the interrupt line versus the same interrupt on the interrupt line. The target of the EOI is given by the local APIC through the transmission of the priority vector (V7 through V0) of the interrupt. Upon receiving this message, the I/O APIC resets the Remote IRR bit for that interrupt. If the interrupt signal is still active after the IRR bit is reset, the I/O APIC will treat it as a new interrupt.

Table 5-20. EOI Message

Cycle	Bit 1	Bit 0	Comments
1	0	0	EOI message
2–5	ARBID	1	Arbitration ID
6	NOT(V7)	NOT(V6)	Interrupt vector bits V7 - V0 from redirection table register
7	NOT(V5)	NOT(V4)	
8	NOT(V3)	NOT(V2)	
9	NOT(V1)	NOT(V0)	
10	NOT(C1)	NOT(C0)	Check Sum from Cycles 6–9
11	1	1	Postamble
12	NOT(A)	NOT(A)	Status Cycle 0
13	NOT(A1)	NOT(A1)	Status Cycle 1
14	1	1	Idle

Short Message

Short messages are used for the delivery of Fixed, NMI, SMI, Reset, ExtINT, and Lowest Priority with Focus processor interrupts. The Delivery Mode bits (M2–M0) specify the message. All short messages take 21 cycles including the idle cycle.

Table 5-21. Short Message

Cycle	Bit 1	Bit 0	Comments
1	1	0	Normal Arbitration
2–5	ARBID	1	Arbitration ID
6	NOT(DM)	NOT(M2)	DM ¹ = Destination Mode from bit 11 of the redirection table register
7	NOT(M1)	NOT(M0)	M2-M0 = Delivery Mode from bits 10:8 of the redirection table register
8	NOT(L)	NOT(TM)	L = Level, TM = Trigger Mode
9	NOT(V7)	NOT(V6)	Interrupt vector bits V7 - V0 from redirection table register
10	NOT(V5)	NOT(V4)	
11	NOT(V3)	NOT(V2)	
12	NOT(V1)	NOT(V0)	
13	NOT(D7)	NOT(D6)	Destination field from bits 63:56 of redirection table register ¹
14	NOT(D5)	NOT(D4)	
15	NOT(D3)	NOT(D2)	
16	NOT(D1)	NOT(D0)	
17	NOT(C1)	NOT(C0)	Checksum for Cycles 6–16 ²
18	1	1	Postamble ³
19	NOT(A)	NOT(A)	Status Cycle 0. See Table 5-22 .
20	NOT(A1)	NOT(A1)	Status Cycle 1. See Table 5-22 .
21	1	1	Idle

NOTES:

1. If DM is 0 (physical mode), cycles 15 and 16 are the APIC ID and cycles 13 and 14 are sent as 1. If DM is 1 (logical mode), cycles 13 through 16 are the 8-bit Destination field. The interpretation of the logical mode 8-bit Destination field is performed by the local units using the Destination Format Register. Shorthands of “all-incl-self” and “all-excl-self” both use physical destination mode and a destination field containing APIC ID value of all ones. The sending APIC knows whether it should (incl) or should not (excl) respond to its own message.
2. The checksum field is the cumulative add (mod 4) of all data bits (DM, M0–3, L, TM, V0–7, D0–7). The APIC driving the message provides this checksum. This, in essence, is the lower two bits of an adder at the end of the message.
3. This cycle allows all APICs to perform various internal computations based on the information contained in the received message. One of the computations takes the checksum of the data received in cycles 6 through 16 and compares it with the value in cycle 18. If any APIC computes a different checksum than the one passed in cycle 17, then that APIC will signal an error on the APIC bus (“00”) in cycle 19. If this happens, all APICs will assume the message was never sent and the sender must try sending the message again, which includes re-arbitrating for the APIC bus. In lowest priority delivery when the interrupt has a focus processor, the focus processor will signal this by driving a 01 during cycle 19. This tells all the other APICs that the interrupt has been accepted, the arbitration is preempted, and short message format is used. Cycle 19 and 20 indicates the status of the message (i.e., accepted, check sum error, retry, or error). [Table 5-22](#) shows the status signal combinations and their meanings for all delivery modes.

Table 5-22. APIC Bus Status Cycle Definition

Delivery Mode	A	Comments	A1	Comments
Fixed, EOI	11	Checksum OK	1x	Error
			01	Accepted
			00	Retry
	10	Error	xx	
	01	Error	xx	
	00	Checksum Error	xx	
NMI, SMM, Reset, ExtINT	11	Checksum OK	1x	Error
			01	Accepted
			00	Error
	10	Error	xx	
	01	Error	xx	
	00	Checksum Error	xx	
Lowest Priority	11	Checksum OK: No Focus Processor	1x	Error
			01	End and Retry
			00	Go for Low Priority Arbitration
	10	Error	xx	
	01	Checksum OK: Focus Processor	xx	
	00	Checksum Error	xx	
Remote Read	11	Checksum OK	xx	
	10	Error	xx	
	01	Error	xx	
	00	Checksum Error	xx	

Lowest Priority without Focus Processor (FP) Message

This message format is used to deliver an interrupt in the lowest priority mode in which it does not have a Focus Process. Cycles 1 through 21 for this message is same as for the short message discussed above. Status cycle 19 identifies if there is a Focus processor (10) and a status value of 11 in cycle 20 indicates the need for lowest priority arbitration.

Table 5-23. Lowest Priority Message (Without Focus Processor)

Cycle	Bit 1	Bit 0	Comments
1	1	0	Normal Arbitration
2–5	ARBID	1	Arbitration ID
6	NOT(DM)	NOT(M2)	DM = Destination Mode from bit 11 of the redirection table register
7	NOT(M1)	NOT(M0)	M2-M0 = Delivery Mode from bits 10:8 of the redirection table register
8	NOT(L)	NOT(TM)	L = Level, TM = Trigger Mode
9	NOT(V7)	NOT(V6)	Interrupt vector bits V7–V0 from redirection table register
10	NOT(V5)	NOT(V4)	
11	NOT(V3)	NOT(V2)	
12	NOT(V1)	NOT(V0)	
13	NOT(D7)	NOT(D6)	Destination field from bits 63:56 of redirection table register
14	NOT(D5)	NOT(D4)	
15	NOT(D3)	NOT(D2)	
16	NOT(D1)	NOT(D0)	
17	NOT(C1)	NOT(C0)	Checksum for Cycles 6–16
18	1	1	Postamble
19	NOT(A)	NOT(A)	Status Cycle 0.
20	NOT(A1)	NOT(A1)	Status Cycle 1.
21	P7	1	Inverted Processor Priority P7–P0
22	P6	1	
23	P5	1	
24	P4	1	
25	P3	1	
26	P2	1	
27	P1	1	
28	P0	1	
29	ArbID3	1	
30	ArbID2	1	
31	ArbID1	1	
32	ArbID0	1	
33	S	S	Status
34	1	1	Idle

NOTES:

1. Cycle 21 through 28 are used to arbitrate for the lowest priority processor. The processor that takes part in the arbitration drives the processor priority on the bus. Only the local APICs that have "free interrupt slots" will participate in the lowest priority arbitration.
2. Cycles 29 through 32 are used to break a tie in case two more processors have lowest priority. The bus arbitration IDs are used to break the tie.

Remote Read Message

Remote read message is used when a local APIC wishes to read the register in another local APIC. The I/O APIC in the ICH4 neither generates or responds to this cycle. The message format is same as short message for the first 21 cycles.

Table 5-24. Remote Read Message

Cycle	Bit 1	Bit 0	Comments
1	1	0	Normal Arbitration
2–5	ARBID	1	Arbitration ID
6	NOT(DM)	NOT(M2)	DM = Destination Mode from bit 11 of the redirection table register
7	NOT(M1)	NOT(M0)	M2-M0 = Delivery Mode from bits 10:8 of the redirection table register
8	NOT(L)	NOT(TM)	L = Level, TM = Trigger Mode
9	NOT(V7)	NOT(V6)	Interrupt vector bits V7–V0 from redirection table register
10	NOT(V5)	NOT(V4)	
11	NOT(V3)	NOT(V2)	
12	NOT(V1)	NOT(V0)	
13	NOT(D7)	NOT(D6)	Destination field from bits 63:56 of redirection table register
14	NOT(D5)	NOT(D4)	
15	NOT(D3)	NOT(D2)	
16	NOT(D1)	NOT(D0)	
17	NOT(C1)	NOT(C0)	Checksum for Cycles 6–16
18	1	1	Postamble
19	NOT(A)	NOT(A)	Status Cycle 0.
20	NOT(A1)	NOT(A1)	Status Cycle 1.
21	d31	d30	Remote register data 31-0
22	d29	d28	
23	d27	d26	
24	d25	d24	
25	d23	d22	
26	d21	d20	
27	d19	d18	
28	d17	d16	
29	d15	d14	
30	d13	d12	
31	d11	d10	
32	d09	d08	
33	d07	d06	
34	d05	d04	
35	d03	d02	
36	d01	d00	
37	S	S	Data Status: 00 = valid, 11 = invalid
38	C	C	Check Sum for data d31-d00
39	1	1	Idle

NOTE: Cycle 21 through 36 contain the remote register data. The status information in cycle 37 specifies if the data is good or not. Remote read cycle is always successful (although the data may be valid or invalid) in that it is never retried. The reason for this is that Remote Read is a debug feature, and a "hung" remote APIC that is unable to respond should not cause the debugger to hang.

5.8.4 PCI Message-Based Interrupts

5.8.4.1 Theory of Operation

The following scheme is only supported when the internal I/O(x) APIC is used (rather than just the 8259).

The ICH4 supports the new method for PCI devices to deliver interrupts as write cycles, rather than using the traditional PIRQ[A:D] signals. Essentially, the PCI devices are given a write path directly to a register that will cause the desired interrupt. This mode is only supported when the ICH4's internal I/O APIC is enabled. Upon recognizing the write from the peripheral, the ICH4 sends the interrupt message to the processor using the I/O APIC's serial bus.

The interrupts associated with the PCI Message-based interrupt method must be set up for edge triggered mode, rather than level triggered, since the peripheral only does the write to indicate the edge.

The following sequence is used:

1. During PCI PnP, the PCI peripheral is first programmed with an address (MESSAGE_ADDRESS) and data value (MESSAGE_DATA) that will be used for the interrupt message delivery. For the ICH4, the MESSAGE_ADDRESS is the IRQ Pin Assertion Register, which is mapped to memory location FEC0_0020h.
2. To cause the interrupt, the PCI peripheral requests the PCI bus and when granted, writes the MESSAGE_DATA value to the location indicated by the MESSAGE_ADDRESS. The MESSAGE_DATA value indicates which interrupt occurred. This MESSAGE_DATA value is a binary encoded. For example, to indicate that interrupt 7 should go active, the peripheral writes a binary value of 0000111. The MESSAGE_DATA is a 32-bit value, although only the lower 5 bits are used.
3. If the PRQ bit in the APIC Version register is set, the ICH4 positively decodes the cycles (as a slave) in medium time.
4. The ICH4 decodes the binary value written to MESSAGE_ADDRESS and sets the appropriate IRR bit in the internal I/O APIC. The corresponding interrupt must be set up for edge-triggered interrupts. The ICH4 supports interrupts 00h through 23h. Binary values outside this range will not cause any action.
5. After sending the interrupt message to the processor, the ICH4 automatically clears the interrupt.

Because they are edge-triggered, the interrupts that are allocated to the PCI bus for this scheme may not be shared with any other interrupt (e.g., the standard PCI PIRQ[A:D], those received via SERIRQ#, or the internal level-triggered interrupts such as SCI or TCO).

The ICH4 ignores interrupt messages sent by PCI masters that attempt to use IRQ0, 2, 8, or 13.

5.8.4.2 Registers and Bits Associated with PCI Interrupt Delivery

Capabilities Indication

The capability to support PCI interrupt delivery is indicated via ACPI configuration techniques. This involves the BIOS creating a data structure that gets reported to the ACPI configuration software. The OS reads the PRQ bit in the APIC Version Register to see if the ICH4 is capable of support PCI-based interrupt messages. As a precaution, the PRQ bit is not set if the XAPIC_EN bit is not set.

Interrupt Message Register

The PCI devices all write their message into the IRQ Pin Assertion Register, which is a memory-mapped register located at the APIC base memory location + 20h.

5.8.5 Processor System Bus Interrupt Delivery

5.8.5.1 Theory of Operation

For processors that support Processor System Bus interrupt delivery, the ICH4 has an option to let the integrated I/O APIC behave as an I/O (x) APIC. In this case, it will deliver interrupt messages to the processor in a parallel manner, rather than using the I/O APIC serial scheme. The ICH4 is intended to be compatible with the *I/O (x) APIC specification, Rev 1.1*.

This is done by the ICH4 writing (via the Hub Interface) to a memory location that is snooped by the processor(s). The processor(s) snoop the cycle to know which interrupt goes active.

The processor enables the mode by setting the I/O APIC Enable (APIC_EN) bit and by setting the DT bit in the I/O APIC ID register.

The following sequence is used:

1. When the ICH4 detects an interrupt event (active edge for edge-triggered mode or a change for level-triggered mode), it sets or resets the internal IRR bit associated with that interrupt.
2. Internally, the ICH4 requests to use the bus in a way that automatically flushes upstream buffers. This can be internally implemented similar to a DMA device request.
3. The ICH4 then delivers the message by performing a write cycle to the appropriate address with the appropriate data. The address and data formats are described below in [Section 5.8.5.5](#).

Note: PSB Interrupt Delivery compatibility with processor clock control depends on the processor, not the ICH4.

5.8.5.2 Edge-Triggered Operation

In this case, the “Assert Message” is sent when there is an inactive-to-active edge on the interrupt.

5.8.5.3 Level-Triggered Operation

In this case, the Assert Message is sent when there is an inactive-to-active edge on the interrupt. If after the EOI the interrupt is still active, then another Assert Message is sent to indicate that the interrupt is still active.

5.8.5.4 Registers Associated with Processor System Bus Interrupt Delivery

Capabilities Indication

The capability to support Processor System Bus interrupt delivery is indicated via ACPI configuration techniques. This involves the BIOS creating a data structure that gets reported to the ACPI configuration software.

DT Bit in the Boot Configuration Register

This enables the ICH4 to deliver interrupts as memory writes. This bit is ignored if the APIC mode is not enabled.

5.8.5.5 Interrupt Message Format

The ICH4 writes the message to PCI (and to the Host controller) as a 32-bit memory write cycle. It uses the formats shown in [Table 5-25](#) and [Table 5-26](#) for the Address and Data.

The local APIC (in the processor) has a delivery mode option to interpret Processor System Bus messages as a SMI in which case the processor treats the incoming interrupt as a SMI instead of as an interrupt. This does not mean that the ICH4 has any way to have a SMI source from ICH4 power management logic cause the I/OAPIC to send an SMI message (there is no way to do this). The ICH4's I/OAPIC can only send interrupts due to interrupts which do not include SMI, NMI or INIT. This means that in IA32/IA64 based platforms, Processor System Bus interrupt message format delivery modes 010 (SMI/PMI), 100 (NMI), and 101 (INIT) as indicated in this section, must not be used and is not supported. Only the hardware pin connection is supported by ICH4.

Table 5-25. Interrupt Message Address Format

Bit	Description
31:20	Will always be FEEh
19:12	Destination ID: This will be the same as bits 63:56 of the I/O Redirection Table entry for the interrupt associated with this message.
11:4	Extended Destination ID: This will be the same as bits 55:48 of the I/O Redirection Table entry for the interrupt associated with this message.
3	Redirection Hint: This bit is used by the processor host bridge to allow the interrupt message to be redirected. 0 = The message will be delivered to the agent (processor) listed in bits 19:12. 1 = The message will be delivered to an agent with a lower interrupt priority This can be derived from bits 10:8 in the Data Field (see below). The Redirection Hint bit will be a 1 if bits 10:8 in the delivery mode field associated with corresponding interrupt are encoded as 001 (Lowest Priority). Otherwise, the Redirection Hint bit will be 0.
2	Destination Mode: This bit is used only when the Redirection Hint bit is set to 1. If the Redirection Hint bit and the Destination Mode bit are both set to 1, then the logical destination mode is used, and the redirection is limited only to those processors that are part of the logical group as based on the logical ID.
1:0	Will always be 00.

Table 5-26. Interrupt Message Data Format

Bit	Description
31:16	Will always be 0000h.
15	Trigger Mode: 1 = Level, 0 = Edge. Same as the corresponding bit in the I/O Redirection Table for that interrupt.
14	Delivery Status: 1 = Assert, 0 = Deassert. If using edge-triggered interrupts, then bit will always be 1, since only the assertion is sent. If using level-triggered interrupts, then this bit indicates the state of the interrupt input.
13:12	Will always be 00.
11	Destination Mode: 1 = Logical. 0 = Physical. Same as the corresponding bit in the I/O Redirection Table for that interrupt.
10:8	Delivery Mode: This is the same as the corresponding bits in the I/O Redirection Table for that interrupt. 000 = Fixed 100 = NMI 001 = Lowest Priority 101 = INIT 010 = SMI/PMI 110 = Reserved 011 = Reserved 111 = ExtINT
7:0	Vector: This is the same as the corresponding bits in the I/O Redirection Table for that interrupt.

5.9 Serial Interrupt (D31:F0)

The ICH4 supports a serial IRQ scheme. This allows a single signal to be used to report interrupt requests. The signal used to transmit this information is shared between the host, the ICH4, and all peripherals that support serial interrupts. The signal line, SERIRQ, is synchronous to PCI clock, and follows the sustained tri-state protocol that is used by all PCI signals. This means that if a device has driven SERIRQ low, it will first drive it high synchronous to PCI clock and release it the following PCI clock. The serial IRQ protocol defines this sustained tri-state signaling in the following fashion:

- **S - Sample Phase.** Signal driven low
- **R - Recovery Phase.** Signal driven high
- **T - Turn-around Phase.** Signal released

The ICH4 supports a message for 21 serial interrupts. These represent the 15 ISA interrupts (IRQ[0:1, 2:15]), the four PCI interrupts, and the control signals SMI# and IOCHK#. The serial IRQ protocol does not support the additional APIC interrupts (20–23).

Note: When the IDE primary and secondary controllers are configured for native IDE mode, the only way to use the internal IRQ14 and IRQ15 connections to the Interrupt controllers is through the Serial Interrupt pin.

5.9.1 Start Frame

The serial IRQ protocol has two modes of operation which affect the start frame. These two modes are: Continuous, where the ICH4 is solely responsible for generating the start frame; and Quiet, where a serial IRQ peripheral is responsible for beginning the start frame.

The mode that must first be entered when enabling the serial IRQ protocol is continuous mode. In this mode, the ICH4 asserts the start frame. This start frame is 4-, 6-, or 8-PCI clocks wide, based upon the Serial IRQ Control Register (bits 1:0 at 64h in Device 31:Function 0 configuration space). This is a polling mode.

When the serial IRQ stream enters quiet mode (signaled in the Stop Frame), the SERIRQ line remains inactive and pulled up between the Stop and Start Frame until a peripheral drives the SERIRQ signal low. The ICH4 senses the line low and continues to drive it low for the remainder of the Start Frame. Since the first PCI clock of the start frame was driven by the peripheral in this mode, the ICH4 drives the SERIRQ line low for 1 PCI clock less than in continuous mode. This mode of operation allows for a quiet, and, therefore, lower power operation.

5.9.2 Data Frames

Once the Start frame has been initiated, all of the SERIRQ peripherals must start counting frames based on the rising edge of SERIRQ. Each of the IRQ/DATA frames has exactly three phases of one clock each:

- Sample Phase.** During this phase, the SERIRQ device drives SERIRQ low if the corresponding interrupt signal is low. If the corresponding interrupt is high, then the SERIRQ devices will tri-state the SERIRQ signal. The SERIRQ line will remain high due to pull-up resistors (there is no internal pull-up resistor on this signal, an external pull-up resistor is required). A low level during the IRQ0-1 and IRQ2-15 frames indicates that an active-high ISA interrupt is not being requested, but a low level during the PCI INT[A:D], SMI#, and IOCHK# frame indicates that an active-low interrupt is being requested.
- Recovery Phase.** During this phase, the device drives the SERIRQ line high if in the Sample Phase it was driven low. If it was not driven in the sample phase, it will be tri-stated in this phase.
- Turn-around Phase.** The device will tri-state the SERIRQ line

5.9.3 Stop Frame

After all data frames, a Stop Frame are driven by the ICH4. The SERIRQ signal is driven low by the ICH4 for 2 or 3 PCI clocks. The number of clocks is determined by the SERIRQ configuration register. The number of clocks determines the next mode:

Table 5-27. Stop Frame Explanation

Stop Frame Width	Next Mode
2 PCI clocks	Quiet Mode. Any SERIRQ device may initiate a Start Frame
3 PCI clocks	Continuous Mode. Only the host (ICH4) may initiate a Start Frame

5.9.4 Specific Interrupts Not Supported via SERIRQ

There are three interrupts seen through the serial stream which are not supported by the ICH4. These interrupts are generated internally and are not sharable with other devices within the system. These interrupts are:

- IRQ0. Heartbeat interrupt generated off of the internal 8254 counter 0.
- IRQ8#. RTC interrupt can only be generated internally.
- IRQ13. Floating point error interrupt generated off of the processor assertion of FERR#.

The ICH4 ignores the state of these interrupts in the serial stream, and does not adjust their level based on the level seen in the serial stream. In addition, the interrupts IRQ14 and IRQ15 from the serial stream are treated differently than their ISA counterparts. These two frames are not passed to the Bus Master IDE logic. The Bus Master IDE logic expects IDE to be behind the ICH4.

5.9.5 Data Frame Format

Table 5-28 shows the format of the data frames. For the PCI interrupts (A–D), the output from the ICH4 is ANDed with the PCI input signal. This way, the interrupt can be signaled via both the PCI interrupt input signal and via the SERIRQ signal (they are shared).

Table 5-28. Data Frame Format

Data Frame #	Interrupt	Clocks Past Start Frame	Comment
1	IRQ0	2	Ignored. IRQ0 can only be generated via the internal 8254
2	IRQ1	5	
3	SMI#	8	Causes SMI# if low. Will set the SERIRQ_SMI_STS bit.
4	IRQ3	11	
5	IRQ4	14	
6	IRQ5	17	
7	IRQ6	20	
8	IRQ7	23	
9	IRQ8	26	Ignored. IRQ8# can only be generated internally or on ISA.
10	IRQ9	29	
11	IRQ10	32	
12	IRQ11	35	
13	IRQ12	38	
14	IRQ13	41	Ignored. IRQ13 can only be generated from FERR#
15	IRQ14	44	Do not include in BM IDE interrupt logic
16	IRQ15	47	Do not include in BM IDE interrupt logic
17	IOCHCK#	50	Same as ISA IOCHCK# going active.
18	PCI INTA#	53	Drive PIRQA#
19	PCI INTB#	56	Drive PIRQB#
20	PCI INTC#	59	Drive PIRQC#
21	PCI INTD#	62	Drive PIRQD#

5.10 Real Time Clock (D31:F0)

The Real Time Clock (RTC) module provides a battery backed-up date and time keeping device with two banks of static RAM with 128 bytes each, although the first bank has 114 bytes for general purpose usage. Three interrupt features are available: time of day alarm with once a second to once a month range, periodic rates of 122 μ s to 500 ms, and end of update cycle notification. Seconds, minutes, hours, days, day of week, month, and year are counted. Daylight savings compensation is optional. The hour is represented in twelve or twenty-four hour format, and data can be represented in BCD or binary format. The design is meant to be functionally compatible with the Motorola MS146818B. The time keeping comes from a 32.768 kHz oscillating source, which is divided to achieve an update every second. The lower 14 bytes on the lower RAM block has very specific functions. The first ten are for time and date information. The next four (0Ah to 0Dh) are registers, which configure and report RTC functions.

The time and calendar data should match the data mode (BCD or binary) and hour mode (12 or 24 hour) as selected in register B. It is up to the programmer to make sure that data stored in these locations is within the reasonable values ranges and represents a possible date and time. The exception to these ranges is to store a value of C0–FF in the Alarm bytes to indicate a don't care situation. All Alarm conditions must match to trigger an Alarm Flag, which could trigger an Alarm Interrupt if enabled. The SET bit must be one while programming these locations to avoid clashes with an update cycle. Access to time and date information is done through the RAM locations. If a RAM read from the ten time and date bytes is attempted during an update cycle, the value read will not necessarily represent the true contents of those locations. Any RAM writes under the same conditions will be ignored.

Note: The ICH4 supports the ability to generate an SMI# based on Year 2000 rollover. See [Section 5.10.4](#) for more information on the century rollover.

The ICH4 does not implement month/year alarms.

5.10.1 Update Cycles

An update cycle occurs once a second, if the SET bit of register B is not asserted and the divide chain is properly configured. During this procedure, the stored time and date will be incremented, overflow will be checked, a matching alarm condition will be checked, and the time and date will be rewritten to the RAM locations. The update cycle will start at least 488 μ s after the UIP bit of register A is asserted, and the entire cycle will not take more than 1984 μ s to complete. The time and date RAM locations (0–9) will be disconnected from the external bus during this time.

To avoid update and data corruption conditions, external RAM access to these locations can safely occur at two times. When a updated-ended interrupt is detected, almost 999 ms is available to read and write the valid time and date data. If the UIP bit of Register A is detected to be low, there is at least 488 μ s before the update cycle begins.

Warning: The overflow conditions for leap years and daylight savings adjustments are based on more than one date or time item. To ensure proper operation when adjusting the time, the new time and data values should be set at least two seconds before one of these conditions (leap year, daylight savings time adjustments) occurs.

5.10.2 Interrupts

The real-time clock interrupt is internally routed within the ICH4 both to the I/O APIC and the 8259. It is mapped to interrupt vector 8. This interrupt does not leave the ICH4, nor is it shared with any other interrupt. IRQ8# from the SERIRQ stream is ignored.

5.10.3 Lockable RAM Ranges

The RTC's battery-backed RAM supports two, 8-byte ranges that can be locked via the configuration space. If the locking bits are set, the corresponding range in the RAM will not be readable or writable. A write cycle to those locations will have no effect. A read cycle to those locations will not return the location's actual value (may be all zeros or all ones).

Once a range is locked, the range can be unlocked only by a hard reset, which will invoke the BIOS and allow it to relock the RAM range.

5.10.4 Century Rollover

The ICH4 detects a rollover when the Year byte (RTC I/O space, index offset 09h) transitions from 99 to 00. Upon detecting the rollover, the ICH4 will set the NEWCENTURY_STS bit (TCOBASE + 04h, bit 7). If the system is in an S0 state, this will cause an SMI#. The SMI# handler can update registers in the RTC RAM that are associated with century value. If the system is in a sleep state (S1-S5) when the century rollover occurs, the ICH4 will also set the NEWCENTURY_STS bit, but no SMI# is generated. When the system resumes from the sleep state, BIOS should check the NEWCENTURY_STS bit and update the century value in the RTC RAM.

5.10.5 Clearing Battery-Backed RTC RAM

Clearing CMOS RAM in an ICH4-based platform can be done by using a jumper on RTCRST# or GPI, or using SAFEMODE strap. Implementations should not attempt to clear CMOS by using a jumper to pull VccRTC low.

Using RTCRST# to clear CMOS

A jumper on RTCRST# can be used to clear CMOS values, as well as reset to default, the state of those configuration bits that reside in the RTC power well. When the RTCRST# is strapped to ground, the RTC_PWR_STS bit (D31:F0:A4h bit 2) is set and those configuration bits in the RTC power well will be set to their default state. BIOS can monitor the state of this bit and manually clear the RTC CMOS array once the system is booted. The normal position would cause RTCRST# to be pulled up through a weak pull-up resistor. [Table 5-29](#) shows which bits are set to their default state when RTCRST# is asserted.

Table 5-29. Configuration Bits Reset By RTCRST# Assertion

Bit Name	Default State	Register	Location	Bit(s)
FREQ_STRAP[3:0]	GEN_STS	D31:F0:D4h	11:8	1111b
AIE	RTC Reg B	I/O space	5	0
AF	RTC Reg C	I/O space	5	0
PWR_FLR	GEN_PMCON_3	D31:F0:A4h	1	0
AFTERG3_EN	GEN_PMCON_3	D31:F0:A4h	0	0
RTC_PWR_STS	GEN_PMCON_3	D31:F0:A4h	2	1
PRBTNOR_STS	PM1_STS	PMBase + 00h	11	0
PME_EN	GPE0_EN	PMBase + 2Ah	11	0
RI_EN	GPE0_EN	PMBase + 2Ah	8	0
NEW_CENTURY_STS	TCO1_STS	TCOBase + 04h	7	0
INTRD_DET	TCO2_STS	TCOBase + 06h	0	0
TOP_SWAP	GEN_STS	D31:F0:D4h	13	0
RTC_EN	PM1_EN	PMBase + 02h	10	0

Using a GPI to Clear CMOS

A jumper on a GPI can also be used to clear CMOS values. BIOS would detect the setting of this GPI on system boot-up, and manually clear the CMOS array.

Using the SAFEMODE Strap to Clear CMOS

A jumper on AC_SDOOUT (SAFEMODE strap) can also be used to clear CMOS values. BIOS would detect the setting of the SAFE_MODE status bit (D31:F0: Offset D4h bit 2) on system boot-up, and manually clear the CMOS array.

Note: Both the GPI and SAFEMODE strap techniques to clear CMOS require multiple steps to implement. The system is booted with the jumper in new position, then powered back down. The jumper is replaced back to the normal position, then the system is rebooted again. The RTCRST# jumper technique allows the jumper to be moved and then replaced, all while the system is powered off. Then, once booted, the RTC_PWR_STS can be detected in the set state.

Note: Clearing CMOS, using a jumper on VccRTC, must **not** be implemented.

5.11 Processor Interface (D31:F0)

The ICH4 interfaces to the processor with a variety of signals

- Standard Outputs to processor: A20M#, SMI#, NMI, INIT#, INTR, STPCLK#, IGNNE#, CPUSLP#
- Standard Input from processor: FERR#

Most ICH4 outputs to the processor use standard buffers. The ICH4 has a separate V_{CC} signal which is pulled up at the system level to the processor voltage, and thus determines V_{OH} for the outputs to the processor. Note that this is different than previous generations of chips, that have used open-drain outputs. This new method saves up to 12 external pull-up resistors.

The ICH4 also handles the speed setting for the processor by holding specific signals at certain states just prior to CPURST going inactive. This avoids the glue often required with other chipsets.

The ICH4 does not support the processor's FRC mode.

5.11.1 Processor Interface Signals

This section describes each of the signals that interface between the ICH4 and the processor(s). Note that the behavior of some signals may vary during processor reset, as the signals are used for frequency strapping.

5.11.1.1 A20M#

The A20M# signal will be active (low) when both of the following conditions are true:

- The ALT_A20_GATE bit (Bit 1 of PORT92 register) is a 0
- The A20GATE input signal is a 0

The A20GATE input signal is expected to be generated by the external microcontroller (KBC).

5.11.1.2 INIT#

The INIT# signal will be active (driven low) based on any one of several events described in [Table 5-30](#). When any of these events occur, INIT# will be driven low for 16 PCI clocks, then driven high.

Note: The 16-clock counter for INIT# assertion will halt while STPCLK# is active. Therefore, if INIT# is supposed to go active while STPCLK# is asserted, it will actually go active after STPCLK# goes inactive.

Table 5-30. INIT# Going Active

Cause of INIT# Going Active	Comment
Shutdown special cycle from processor.	
PORT92 write, where INIT_NOW (bit 0) transitions from a 0 to a 1.	
PORTCF9 write, where RST_CPU (bit 2) was a 0 and SYS_RST(bit 1) transitions from 0 to 1.	
RCIN# input signal goes low. RCIN# is expected to be driven by the external microcontroller (KBC).	0 to 1 transition on RCIN# must occur before the ICH4 will arm INIT# to be generated again. NOTE: RCIN# signal is expected to be low during S3, S4, and S5 states. Transition on the RCIN# signal in those states (or the transition to those states) may not necessarily cause the INIT# signal to be generated to the processor.
CPU BIST	To enter BIST, the software sets CPU_BIST_EN bit and then does a full processor reset using the CF9 register.

5.11.1.3 FERR#/IGNNE# (Coprocessor Error)

The ICH4 supports the coprocessor error function with the FERR#/IGNNE# pins. The function is enabled via the COPROC_ERR_EN bit (Device 31:Function 0, Offset D0, bit 13). FERR# is tied directly to the Coprocessor Error signal of the processor. If FERR# is driven active by the processor, IRQ13 goes active (internally). When it detects a write to the COPROC_ERR register, the ICH4 negates the internal IRQ13 and drives IGNNE# active. IGNNE# remains active until FERR# is driven inactive. IGNNE# is never driven active unless FERR# is active.

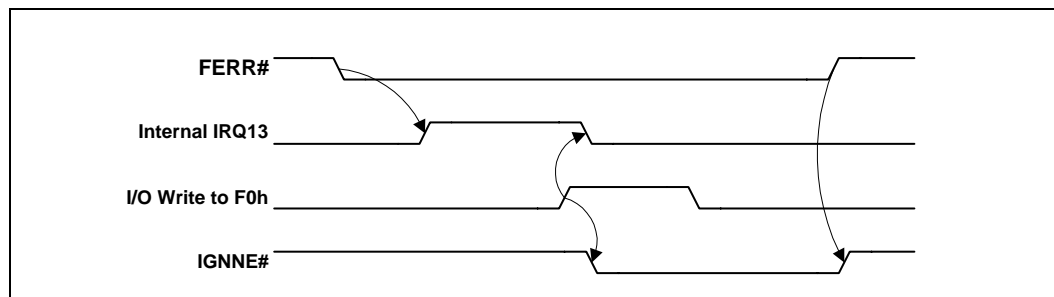
Figure 5-12. Coprocessor Error Timing Diagram

If COPROC_ERR_EN is not set, then the assertion of FERR# will have not generate an internal IRQ13, nor will the write to F0h generate IGNNE#.

5.11.1.4 NMI

Non-Maskable Interrupts (NMIs) can be generated by several sources, as described in [Table 5-31](#).

Table 5-31. NMI Sources

Cause of NMI	Comment
SERR# goes active (either internally, externally via SERR# signal, or via message from the MCH)	Can instead be routed to generate an SCI, through the NMI2SCI_EN bit (Device 31:Function 0, offset 4E, bit 11).
IOCHK# goes active via SERIRQ# stream (ISA system Error)	Can instead be routed to generate an SCI, through the NMI2SCI_EN bit (Device 31:Function 0, offset 4E, bit 11).

5.11.1.5 STPCLK# and CPUSLP# Signals

The ICH4 power management logic controls these active-low signals. Refer to [Section 5.12](#) for more information on the functionality of these signals.

5.11.1.6 CPUPWRGOOD Signal

This signal is connected to the processor's PWRGOOD input. This is an open-drain output signal (external pull-up resistor required) that represents a logical AND of the ICH4's PWROK and VRMPWRGD signals.

5.11.2 Dual-Processor Designs

5.11.2.1 Signal Differences

In dual-processor (DP) designs, some of the processor signals are unused or used differently than for uniprocessor designs.

Table 5-32. DP Signal Differences

Signal	Difference
A20M# / A20GATE	Generally not used, but still supported by Intel® ICH4.
STPCLK#	Used for S1 State as well as preparation for entry to S3–S5 Also allows for THERM# based throttling (not via ACPI control methods). Should be connected to both processors.
FERR# / IGNNE#	Generally not used, but still supported by ICH4.

5.11.2.2 Power Management

Attempting clock control with more than one processor is not feasible, because the Host controller does not provide any indication as to which processor is executing a particular Stop-Grant cycle. Without this information, there is no way for the ICH4 to know when it is safe to deassert STPCLK#.

Because the S1 state will have the STPCLK# signal active, the STPCLK# signal can be connected to both processors. However, for ACPI implementations, the ICH4 does not support the C2 state for both processors, since there are not two processor control blocks. The BIOS must indicate that the ICH4 only supports the C1 state for dual-processor designs. However, the THRM# signal can be used for overheat conditions to activate thermal throttling.

When entering S1, the ICH4 asserts STPCLK# to both processors. To meet the processor specifications, the CPUSLP# signal will have to be delayed until the second Stop-Grant cycle occurs. To ensure this, the ICH4 waits a minimum of 60 PCI clocks after receipt of the first Stop-Grant cycle before asserting CPUSLP# (if the SLP_EN bit is set to 1).

Both processors must immediately respond to the STPCLK# assertion with stop grant acknowledge cycles before the ICH4 asserts CPUSLP# in order to meet the processor setup time for CPUSLP#. Meeting the processor setup time for CPUSLP# is not an issue if both processors are idle when the system is entering S1. If you cannot guarantee that both processors will be idle, do not enable the SLP_EN bit. Note that setting SLP_EN to 1 is not required to support S1 in a dual-processor configuration.

In going to the S3, S4, or S5 states, the system will appear to pass through the S1 state, and thus STPCLK# and SLP# are also used. During the S3, S4, and S5 states, both processors will lose power. Upon exit from those states, the processors will have their power restored.

5.11.3 Speed Strapping for Processor

The ICH4 directly sets the speed straps for the processor, saving the external logic that has been needed with prior PCIsets. Refer to processor specification for speed strapping definition.

The ICH4 performs the following to set the speed straps for the processor:

1. While PCIRST# is active, the ICH4 drives A20M#, IGNNE#, NMI, and INTR high.
2. As soon as PWROK goes active, the ICH4 reads the `FREQ_STRAP` field contents.
3. The next step depends on the power state being exited as described in [Table 5-33](#).

Table 5-33. Frequency Strap Behavior Based on Exit State

State Exiting	ICH4
S1	There is no processor reset, so no frequency strap logic is used.
S3, S4, S5, or G3	Based on PWROK going active, the ICH4 will deassert PCIRST#, and based on the value of the <code>FREQ_STRAP</code> field (D31:F0, Offset D4), the Intel® ICH4 will drive the intended core frequency values on A20M#, IGNNE#, NMI, and INTR. The ICH4 will hold these signals for 120 ns after CPURST# is deasserted by the Host controller.

Table 5-34. Frequency Strap Bit Mapping

FREQ_STRAP Bits [3:0]	Sets High/Low Level for the Corresponding Signal
3	NMI
2	INTR
1	IGNNE#
0	A20M#

NOTE: The `FREQ_STRAP` register is in the RTC well. The value in the register can be forced to 1111h via a pinstrap (`AC_SDOUT` signal), or the ICH4 can automatically force the speed strapping to 1111h if the processor fails to boot.

Figure 5-13. Signal Strapping

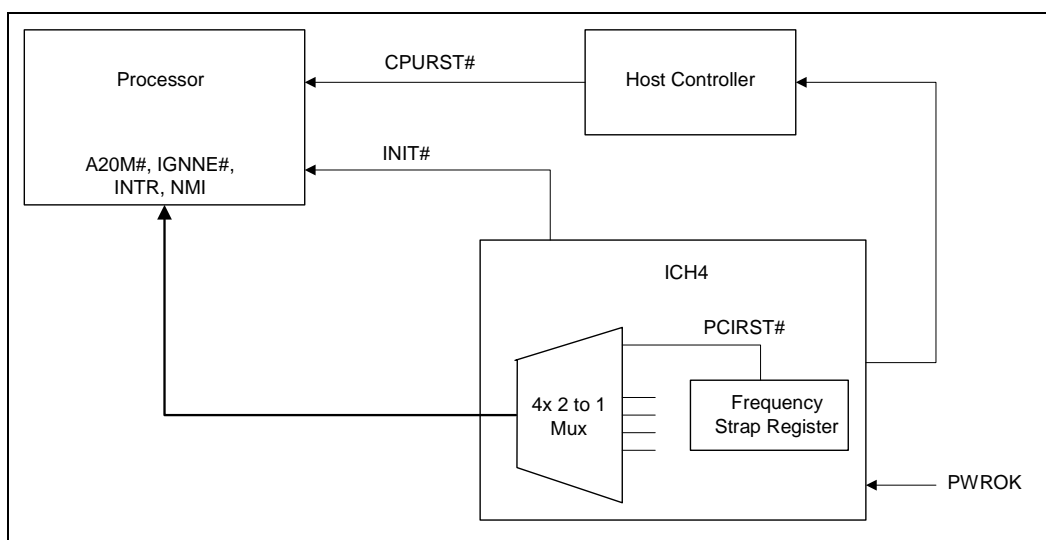

5.12 Power Management (D31:F0)

The power management features include:

- ACPI Power and Thermal Management Support
 - ACPI 24-Bit Timer
 - Software initiated throttling of processor performance for Thermal and Power Reduction
 - Hardware Override to throttle processor performance if system too hot
 - SCI and SMI# Generation
- PCI PME# Signal for Wake Up from Low-Power states
- System Clock Control
 - ACPI C2 state: Stop-Grant state (using STPCLK# signal) halts processor's instruction stream
- System Sleeping State Control
 - ACPI S1 state: Like C2 state (only STPCLK# active, and SLP# optional)
 - ACPI S3 state: Suspend to RAM (STR)
 - ACPI S4 state: Suspend-to-Disk (STD)
 - ACPI G2/S5 state: Soft Off (SOFF)
 - Power Failure Detection and Recovery
- Streamlined Legacy Power Management Support for APM-Based Systems

5.12.1 Intel[®] ICH4 and System Power States

Table 5-35 shows the power states defined for ICH4-based platforms. The state names generally match the corresponding ACPI states.

Table 5-35. General Power States for Systems Using Intel[®] ICH4

State/ Substates	Legacy Name / Description
G0/S0/C0	Full On: Processor operating. Individual devices may be shut down to save power. The different processor operating levels are defined by Cx states, as shown in Table 5-36. Within the C0 state, the Intel [®] ICH4 can throttle the STPCLK# signal to reduce power consumption. The throttling can be initiated by software or by the THRM# input signal.
G0/S0/C1	Auto-Halt: Processor has executed a AutoHalt instruction and is not executing code. The processor snoops the bus and maintains cache coherency.
G0/S0/C2	Stop-Grant: The STPCLK# signal goes active to the processor. The processor performs a Stop-Grant cycle, halts its instruction stream, and remains in that state until the STPCLK# signal goes inactive. In the Stop-Grant state, the processor snoops the bus and maintains cache coherency.
G1/S1	Stop-Grant: Similar to G0/S0/C2 state. ICH4 also has the option to assert the CPUSLP# signal to further reduce processor power consumption. NOTE: The behavior for this state is slightly different when supporting iA64 processors.
G1/S3	Suspend-To-RAM (STR): The system context is maintained in system DRAM, but power is shut off to non-critical circuits. Memory is retained, and refreshes continue. All clocks stop except RTC clock.
G1/S4	Suspend-To-Disk (STD): The context of the system is maintained on the disk. All power is then shut off to the system except for the logic required to resume.
G2/S5	Soft Off (SOFF): System context is not maintained. All power is shut off except for the logic required to restart. A full boot is required when waking.
G3	Mechanical OFF (MOFF): System context not maintained. All power is shut off except for the RTC. No "Wake" events are possible, because the system does not have any power. This state occurs if the user removes the batteries, turns off a mechanical switch, or if the system power supply is at a level that is insufficient to power the "waking" logic. When system power returns, transition will depend on the state just prior to the entry to G3 and the AFTERG3 bit in the GEN_PMC0N3 register (D31:F0, offset A4). Refer to Table 5-43 for more details.

Table 5-36 shows the transitions rules among the various states. Note that transitions among the various states may appear to temporarily transition through intermediate states. For example, in going from S0 to S1, it may appear to pass through the G0/S0/C2 states. These intermediate transitions and states are not listed in the table.

Table 5-36. State Transition Rules for Intel® ICH4

Present State	Transition Trigger	Next State
G0/S0/C0	<ul style="list-style-type: none"> Processor halt instruction Level 2 Read SLP_EN bit set Power Button Override Mechanical Off/Power Failure 	<ul style="list-style-type: none"> G0/S0/C1 G0/S0/C2 G0/S0/C3 G1/Sx or G2/S5state G2/S5 G3
G0/S0/C1	<ul style="list-style-type: none"> Any Enabled Break Event STPCLK# goes active Power Button Override Power Failure 	<ul style="list-style-type: none"> G0/S0/C0 G0/S0/C2 G2/S5 G3
G0/S0/C2	<ul style="list-style-type: none"> Any Enabled Break Event STPCLK# goes inactive and previously in C1 Power Button Override Power Failure 	<ul style="list-style-type: none"> G0/S0/C0 G0/S0/C1 G2/S5 G3
G1/S1, G1/S3, or G1/S4	<ul style="list-style-type: none"> Any Enabled Wake Event Power Button Override Power Failure 	<ul style="list-style-type: none"> G0/S0/C0 G2/S5 G3
G2/S5	<ul style="list-style-type: none"> Any Enabled Wake Event Power Failure 	<ul style="list-style-type: none"> G0/S0/C0 G3
G3	<ul style="list-style-type: none"> Power Returns 	<ul style="list-style-type: none"> Optional to go to S0/C0 (reboot) or G2/S5 (stay off until power button pressed or other wake event). (See Note 1)

NOTES:

- Some wake events can be preserved through power failure.

5.12.2 System Power Planes

The system has several independent power planes, as described in [Table 5-37](#). Note that when a particular power plane is shut off, it should go to a 0 V level.

Table 5-37. System Power Plane

Plane	Controlled By	Description
Processor	SLP_S3# signal	The SLP_S3# signal can be used to cut the processor's power completely
MAIN	SLP_S3# signal	When SLP_S3# goes active, power can be shut off to any circuit not required to wake the system from the S3 state. Since the S3 state requires that the memory context be preserved, power must be retained to the main memory. The processor, devices on the PCI bus, LPC interface downstream hub interface and AGP will typically be shut off when the Main power plane is shut, although there may be small subsections powered.
MEMORY	SLP_S4# signal	When the SLP_S4# goes active, power can be shut off to any circuit not required to wake the system from the S4. Since the memory context does not need to be preserved in the S4 state, the power to the memory can also be shut down.
DEVICE[n]	GPIO	Individual subsystems may have their own power plane. For example, GPIO signals may be used to control the power to disk drives, audio amplifiers, or the display screen.

5.12.3 Intel® ICH4 Power Planes

The ICH4 power planes are defined in [Section 4.1](#). Although there are not specific power planes within the ICH4, there are many interface signals that go to devices that may be powered down. These include:

- IDE: ICH4 can tri-state or drive low all IDE output signals and shut off input buffers.
- USB: ICH4 can tri-state USB output signals and shut off input buffers if USB wakeup is not desired
- AC '97: ICH4 can drive low the outputs and shut off inputs

5.12.4 SMI#/SCI Generation

Upon any SMI# event taking place, ICH4 asserts SMI# to the processor which causes it to enter SMM space. SMI# remains active until the EOS bit is set. When the EOS bit is set, SMI# goes inactive for a minimum of 4 PCICLK. If another SMI event occurs, SMI# is driven active again.

The SCI is a level-mode interrupt that is typically handled by an ACPI-aware operating system. In non-APIC systems (which is the default), the SCI IRQ is routed to one of the 8259 interrupts (IRQ 9, 10, or 11). The 8259 interrupt controller must be programmed to level mode for that interrupt.

In systems using the APIC, the SCI can be routed to interrupts 9, 10, 11, 20, 21, 22, or 23. The interrupt polarity changes depending on whether it is on an interrupt shareable with a PIRQ or not; (see [Section 9.1.11 ACPI Control Register for details](#).) The interrupt will remain asserted until all SCI sources are removed.

Table 5-38 shows which events can cause an SMI# and SCI. Note that some events can be programmed to cause either an SMI# or SCI. The usage of the event for SCI (instead of SMI#) is typically associated with an ACPI-based system. Each SMI# or SCI source has a corresponding enable and status bit.

Table 5-38. Causes of SMI# and SCI (Sheet 1 of 2)

Cause	SCI	SMI	Additional Enables	Where Reported
PME#	Yes	Yes	PME_EN=1	PME_STS
PME_B0 (internal EHCI controller)	Yes	Yes	PME_B0_EN=1	PME_B0_STS
Power Button Press	Yes	Yes	PWRBTN_EN=1	PWRBTN_STS
RTC Alarm	Yes	Yes	RTC_EN=1	RTC_STS
Ring Indicate	Yes	Yes	RI_EN=1	RI_STS
AC '97 wakes	Yes	Yes	AC '97_EN=1	AC '97_STS
USB UHCI #1 wakes	Yes	Yes	USB1_EN=1	USB1_STS
USB UHCI #2 wakes	Yes	Yes	USB2_EN=1	USB2_STS
USB UHCI #3 wakes	Yes	Yes	USB3_EN=1	USB3_STS
THRM# pin active	Yes	Yes	THRM_EN=1	THRM_STS
ACPI Timer overflow (2.34 sec.)	Yes	Yes	TMROF_EN=1	TMROF_STS
Any GPI	Yes	Yes	GPI[x]_Route=10 (SCI) GPI[x]_Route=01 (SMI) GPE0[x]_EN=1	GPI[x]_STS GPE0_STS
TCO SCI Logic	Yes	No	TCOSCI_EN=1	TCOSCI_STS
TCO SCI message from MCH	Yes	No	none	MCHSCI_STS
TCO SMI Logic	No	Yes	TCO_EN=1	TCO_STS
TCO SMI -Year 2000 Rollover	No	Yes	none	NEWCENTURY_STS
TCO SMI -TCO TIMEROUT	No	Yes	none	TIMEOUT
TCO SMI - OS writes to TCO_DAT_IN register	No	Yes	none	OS_TCO_SMI
TCO SMI -Message from MCH	No	Yes	none	MCHSMI_STS
TCO SMI - NMI occurred (and NMIs mapped to SMI)	No	Yes	NMI2SMI_EN=1	NMI2SMI_STS
TCO SMI -INTRUDER# signal goes active	No	Yes	INTRD_SEL=10	INTRD_DET
TCO SMI - Change of the BIOSWP bit from 0 to 1	No	Yes	BLD=1	BIOSWR_STS
TCO SMI -Write attempted to BIOS	No	Yes	BIOSWP=1	BIOSWR_STS
BIOS_RLS written to	Yes	No	GBL_EN=1	GBL_STS
GBL_RLS written to	No	Yes	BIOS_EN=1	BIOS_STS
Write to B2h register	No	Yes	none	APM_STS
Periodic timer expires	No	Yes	PERIODIC_EN=1	PERIODIC_STS
64 ms timer expires	No	Yes	SWSMI_TMR_EN=1	SWSMI_TMR_STS
Enhanced USB Legacy Support Event	No	Yes	LEGACY_USB2_EN = 1	LEGACY_USB2_STS
Enhanced USB Intel Specific Event	No	Yes	INTEL_USB2_EN = 1	INTEL_USB2_STS
Classic USB Legacy logic	No	Yes	LEGACY_USB_EN=1	LEGACY_USB_STS
Serial IRQ SMI reported	No	Yes	none	SERIRQ_SMI_STS

Table 5-38. Causes of SMI# and SCI (Sheet 2 of 2)

Cause	SCI	SMI	Additional Enables	Where Reported
Device monitors match address in its range	No	Yes	DEV[n]_TRAP_EN=1	DEVMON_STS, DEV[n]_TRAP_STS
SMBus Host controller	No	Yes	SMB_SMI_EN Host Controller Enabled	SMBus host status reg.
SMBus Slave SMI message	No	Yes	none	SMBUS_SMI_STS
SMBus SMBALERT# signal active	No	Yes	none	SMBUS_SMI_STS
SMBus Host Notify message received	No	Yes	HOST_NOTIFY_INTREN	SMBUS_SMI_STS HOST_NOTIFY_STS
Access microcontroller 62h/66h	No	Yes	MCSMI_EN	MCSMI_STS
SLP_EN bit written to 1	No	Yes	SMI_ON_SLP_EN=1	SMI_ON_SLP_EN_STS

NOTES:

1. SCI_EN must be 1 to enable SCI. SCI_EN must be 0 to enable SMI.
2. SCI can be routed to cause interrupt 9:11 or 20:23 (20:23 only available in APIC mode).
3. GBL_SMI_EN must be 1 to enable SMI.
4. EOS must be written to 1 to re-enable SMI for the next one.

5.12.5 Dynamic Processor Clock Control

The ICH4 has extensive control for dynamically starting and stopping system clocks. The clock control is used for transitions among the various S0/Cx states, and processor throttling. Each dynamic clock control method is described in this section. The various Sleep states may also perform types of non-dynamic clock control.

The ICH4 supports the ACPI C0, C1, and C2 states.

The Dynamic processor clock control is handled using the following signals:

- STPCLK#: Used to halt processor instruction stream.

The C1 state is entered based on the processor performing an auto halt instruction. The C2 state is entered based on the processor reading the Level 2 register in the ICH4.

A C1, C2 state ends due to a Break event. Based on the break event, the ICH4 returns the system to C0 state. [Table 5-39](#) lists the possible break events from C2. The break events from C1 are indicated in the processor's datasheet.

Table 5-39. Break Events

Event	Breaks from	Comment
Any unmasked interrupt goes active	C2	IRQ[0:15] when using the 8259s, IRQ[0:23] for I/O APIC. Since SCI is an interrupt, any SCI will also be a break event.
Any internal event that will cause an NMI or SMI#	C2	Many possible sources
Any internal event that will cause INIT# to go active	C2	Could be indicated by the keyboard controller via the RCIN input signal.
Processor Pending Break Event Indication	C2	Only available if FERR# enabled for break event indication (See GEN_CNTL.FERR# Mux-En bit in Section 9.1.22).

The ICH4 supports the Pending Break Event (PBE) indication from the processor using the FERR# signal. The following rules apply:

1. When STPCLK# is detected active by the processor, the FERR# signal from the processor will be redefined to indicate whether an interrupt is pending. The signal is active low (i.e., FERR# will be low to indicate a pending interrupt).
2. When the ICH4 asserts STPCLK#, it will latch the current state of the FERR# signal and continue to present this state to the FERR# state machine (independent of what the FERR# pin does after the latching).
3. When the ICH4 detects the Stop-Grant cycle, it will start looking at the FERR# signal as a break event indication. If FERR# is sampled low, a break event is indicated. This will force a transition to the C0 state.
4. When the processor detects the deassertion of STPCLK#, the processor will start driving the FERR# signal with the natural value (i.e., the value it would do if the pin was not muxed). The time from STPCLK# inactive to the FERR# signal transition back to the native function must be less than 120 ns.
5. The ICH4 waits at least 180 ns after deasserting STPCLK# and then starts using the FERR# signal for an indication of a floating point error. The maximum time that the ICH4 may wait is bounded such that it must have a chance to look at the FERR# signal before reasserting STPCLK#. Based on current implementation, that maximum time would be 240 ns (8 PCI clocks).

The break event associated with this new mechanism does not need to set any particular status bit, since the pending interrupt will be serviced by the processor after returning to the C0 state.

5.12.5.1 Throttling Using STPCLK#

Throttling is used to lower power consumption or reduce heat. The ICH4 asserts STPCLK# to throttle the processor clock and the processor appears to temporarily enter a C2 state. After a programmable time, the ICH4 deasserts STPCLK# and the processor appears to return to the C0 state. This allows the processor to operate at reduced average power, with a corresponding decrease in performance. Two methods are included to start throttling:

1. Software enables a timer with a programmable duty cycle. The duty cycle is set by the THTL_DTY field and the throttling is enabled using the THTL_EN field. This is known as Manual Throttling. The period is fixed to be in the non-audible range, due to the nature of switching power supplies.
2. A Thermal Override condition (THRM# signal active for >2 seconds) occurs that unconditionally forces throttling, independent of the THTL_EN bit. The throttling due to Thermal Override has a separate duty cycle (THRM_DTY) which may vary by field and system. The Thermal Override condition will end when THRM# goes inactive.

Throttling due to the THRM# signal has higher priority than the software-initiated throttling. Throttling does not occur when the system is in a C2, even if Thermal override occurs.

5.12.5.2 Transition Rules among S0/Cx and Throttling States

The following priority rules and assumptions apply among the various S0/Cx and throttling states:

- Entry to any S0/Cx state is mutually exclusive with entry to any S1–S5 state. This is because the processor can only perform one register access at a time and Sleep states have higher priority than thermal throttling.
- When the SLP_EN bit is set (system going to a sleep state (S1–S5), the THTL_EN bit can be internally treated as being disabled (no throttling while going to sleep state). Note that thermal throttling (based on THRM# signal) cannot be disabled in an S0 state. However, once the SLP_EN bit is set, the thermal throttling is shut off (since STPCLK# will be active in S1–S5 states).
- If the THTL_EN bit is set, and a Level 2read then occurs, the system should immediately go and stay in a C2state until a break event occurs. A Level 2read has higher priority than the software initiated throttling or thermal throttling.
- If Thermal Override is causing throttling, and a Level 2read then occurs, the system will stay in a C2 state until a break event occurs. A Level 2read has higher priority than the Thermal Override.
- After an exit from a C2state (due to a Break event), and if the THTL_EN bit is still set, or if a Thermal Override is still occurring, the system will continue to throttle STPCLK#. Depending on the time of break event, the first transition on STPCLK# active can be delayed by up to one THRM period (1024 PCI clocks=30.72 microseconds).
- The Host controller must post Stop-Grant cycles in such a way that the processor gets an indication of the end of the special cycle prior to the ICH4 observing the Stop-Grant cycle. This ensures that the STPCLK# signals stays active for a sufficient period after the processor observes the response phase.
- If in the C1 state and the STPCLK# signal goes active, the processor will generate a Stop-Grant cycle, and the system should go to the C2 state. When STPCLK# goes inactive, it should return to the C1 state.

5.12.6 Sleep States

5.12.6.1 Sleep State Overview

The ICH4 directly supports different sleep states (S1–S5), which are entered by setting the SLP_EN bit, or due to a Power Button press. The entry to the Sleep states are based on several assumptions:

- Entry to a Cx state is mutually exclusive with entry to a Sleep state. This is because the processor can only perform one register access at a time. A request to Sleep always has higher priority than throttling.
- Prior to setting the SLP_EN bit, the software turns off processor-controlled throttling. Note that thermal throttling cannot be disabled, but setting the SLP_EN bit disables thermal throttling (since S1–S5 sleep state has higher priority).
- The G3 state cannot be entered via any software mechanism. The G3 state indicates a complete loss of power.

5.12.6.2 Initiating Sleep State

Sleep states (S1–S5) are initiated by:

- Masking interrupts, turning off all bus master enable bits, setting the desired type in the SLP_TYP field, and then setting the SLP_EN bit. The hardware will then attempt to gracefully put the system into the corresponding Sleep state by first going to a C2 state. See [Section 5.12.5](#) for details on going to the C2 state.
- Pressing the PWRBTN# signal for more than 4 seconds to cause a Power Button Override event. In this case the transition to the S5 state will be less graceful, since there will be no dependencies on observing Stop-Grant cycles from the processor or on clocks other than the RTC clock.

Table 5-40. Sleep Types

Sleep Type	Comment
S1	Intel® ICH4 asserts the STPCLK# signal. It also has the option to assert the CPUSLP# signal. This lowers the processor's power consumption. No snooping is possible in this state.
S3	ICH4 asserts SLP_S3#. The SLP_S3# signal will control the power to non-critical circuits. Power will only be retained to devices needed to wake from this sleeping state, as well as to the memory.
S4	ICH4 asserts SLP_S3# and SLP_S4#. The SLP_S4# signal will shut off the power to the memory subsystem. Only devices needed to wake from this state should be powered.
S5	Same power state as S4. ICH4 asserts SLP_S3#, SLP_S4# and SLP_S5#.

5.12.6.3 Exiting Sleep States

Sleep states (S1–S5) are exited based on Wake events. The Wake events force the system to a full on state (S0), although some non-critical subsystems might still be shut off and have to be brought back manually. For example, the hard disk may be shut off during a sleep state, and have to be enabled via a GPIO pin before it can be used.

Upon exit from the ICH4-controlled Sleep states, the WAK_STS bit is set. The possible causes of Wake Events (and their restrictions) are shown in [Table 5-41](#).

Table 5-41. Causes of Wake Events

Cause	States Can Wake From	How Enabled
RTC Alarm	S1–S5 ⁽¹⁾	Set RTC_EN bit in PM1_EN register
Power Button	S1–S5	Always enabled as Wake event
GPI[0:n]	S1–S5 ⁽¹⁾	GPE0_EN register
USB	S1–S5 ⁽³⁾	Set USB1_EN, USB 2_EN and USB3_EN bits in GPE0_EN register
LAN	S1–S5	Will use PME#. Wake enable set with LAN logic.
RI#	S1–S5 ⁽¹⁾	Set RI_EN bit in GPE0_EN register
AC '97	S1–S5	Set AC '97_EN bit in GPE0_EN register
Primary PME#	S1–S5	PME_B0_EN bit in GPE0_EN register
Secondary PME#	S1–S5 ⁽¹⁾	Set PME_EN bit in GPE0_EN Register.
SMBALERT#	S1–S5	Always enabled as Wake event
SMBus Slave Message	S1–S5	Wake/SMI# command always enabled as a Wake Event. NOTE: SMBus Slave Message can wake the system from S1–S5, as well as from S5 due to Power Button Override.
SMBus Host Notify message received	S1–S5	HOST_NOTIFY_WKEN bit SMBus Slave Command register. Reported in the SMB_WAK_STS bit in the GPE0_STS register.
PME_B0 (internal USB EHCI controller)	S1–S5 ⁽¹⁾	Set PME_B0_EN bit in GPE0_EN register.

NOTES:

1. This will be a wake event from S5 only if the sleep state was entered by setting the SLP_EN and SLP_TYP bits via software.
2. If in the S5 state due to a powerbutton override, the possible wake events are due to Power Button, Hard Reset Without Cycling (See Command Type 3 in [Table 5-95](#)), and Hard Reset System (See Command Type 4 in [Table 5-95](#)).
3. The entry for USB changes from being able to wake from S1–S4 to being able to wake from S1–S5. Previous designs actively blocked wake events while in S5. There is no need to do this as software already disables waking from USB on S5 (so the wake bits are masked), and in the future power buttons will move to USB keyboards, and a wake from S5 will be necessary.

It is important to understand that the various GPIs have different levels of functionality when used as wake events. The GPIs that reside in the core power well can only generate wake events from an S1 state. Also only certain GPIs are “ACPI Compliant,” meaning that their Status and Enable bits reside in ACPI I/O space. [Table 5-42](#) summarizes the use of GPIs as wake events.

Table 5-42. GPI Wake Events

GPI	Power Well	Wake From	Notes
GPI[7:0]	Core	S1	
GPI[13:11], GPI[8]	Resume	S1–S5	ACPI Compliant

The latency to exit the various Sleep states varies greatly and is heavily dependent on power supply design, so much so that the exit latencies due to the ICH4 are insignificant.

5.12.6.4 Sx-G3-Sx, Handling Power Failures

In desktop systems, power failures can occur if the AC power is cut (a real power failure) or if the system is unplugged. In either case, PWROK and RSMRST# are assumed to go low.

Depending on when the power failure occurs and how the system is designed, different transitions could occur due to a power failure.

The AFTER_G3 bit provides the ability to program whether or not the system should boot once power returns after a power loss event. If the policy is to not boot, the system will remain in an S5 state (unless previously in S4). There are only three possible events that will wake the system after a power failure.

1. **PWRBTN#:** PWRBTN# is always enabled as a wake event. When RSMRST# is low (G3 state), the PWRBTN_STS bit is reset. When the ICH4 exits G3 after power returns (RSMRST# goes high), the PWRBTN# signal is already high (because VCC-standby goes high before RSMRST# goes high) and the PWRBTN_STS bit is 0.
2. **RI#:** RI# does not have an internal pull-up. Therefore, if this signal is enabled as a wake event, it is important to keep this signal powered during the power loss event. If this signal goes low (active), when power returns, the RI_STS bit will be set and the system will interpret that as a wake event.
3. **RTC Alarm:** The RTC_EN bit is in the RTC well and is preserved after a power loss. Like PWRBTN_STS, the RTC_STS bit is cleared when RSMRST# goes low.

The ICH4 monitors both PWROK and RSMRST# to detect for power failures. If PWROK goes low, the PWROK_FLR bit is set. If RSMRST# goes low, PWR_FLR is set.

Note: Although PME_EN is in the RTC well, this signal cannot wake the system after a power loss. PME_EN is cleared by RTCRST# and PME_STS is cleared by RSMRST#.

Table 5-43. Transitions Due to Power Failure

State at Power Failure	AFTERG3_EN bit	Transition When Power Returns
S0, S1, S3	1 0	S5 S0
S4	1 0	S4 S0
S5	1 0	S5 S0

5.12.7 Thermal Management

The ICH4 has mechanisms to assist with managing thermal problems in the system.

5.12.7.1 THRM# Signal

The THRM# signal is used as a status input for a thermal sensor. Based on the THRM# signal going active, the ICH4 generates an SMI# or SCI (depending on SCI_EN).

If the THRM_POL bit is set low, when the THRM# signal goes low, the THRM_STS bit will be set. This is an indicator that the thermal threshold has been exceeded. If the THRM_EN bit is set, then when THRM_STS goes active, either an SMI# or SCI is generated (depending on the SCI_EN bit being set).

The power management software (BIOS or ACPI) can then take measures to start reducing the temperature. Examples include shutting off unwanted subsystems, or halting the processor.

By setting the THRM_POL bit to high, another SMI# or SCI can optionally be generated when the THRM# signal goes back high. This allows the software (BIOS or ACPI) to turn off the cooling methods.

Note: THRM# assertion does not cause a TCO event message in S3, or S4. The level of the signal will not be reported in the heartbeat message.

5.12.7.2 THRM# Initiated Passive Cooling

If the THRM# signal remains active for some time greater than 2 seconds and the ICH4 is in the S0/G0/C0 state, then the ICH4 enters an auto-throttling mode in which it provides a duty cycle on the STPCLK# signal. This reduces the overall power consumption by the system and should cool the system. The intended result of the cooling is that the THRM# signal should go back inactive.

For all programmed values (001–111), THRM# going active results in STPCLK# active for a minimum time of 12.5% and a maximum of 87.5%. The period is 1024 PCI clocks. Thus, the STPCLK# signal can be active for as little as 128 PCI clocks or as much as 896 PCI clocks. The actual slowdown (and cooling) of the processor depends on the instruction stream, because the processor is allowed to finish the current instruction. Furthermore, the ICH4 waits for the STOP-GRANT cycle before starting the count of the time the STPCLK# signal is active.

When THRM# goes inactive, the throttling will stop. In case the ICH4 is already attempting throttling because the THTL_EN bit is set, the duty cycle associated with the THRM# signal will have higher priority. If the ICH4 is in the C2 or S1–S5 states, then no throttling will be caused by the THRM# signal being active.

5.12.7.3 THRM# Override Software Bit

The FORCE_THTL bit allows the BIOS to force passive cooling, just as if the THRM# signal had been active for two seconds. If this bit is set, the ICH4 starts throttling using the ratio in the THRM_DTY field.

When this bit is cleared, the ICH4 stops throttling, unless the THRM# signal has been active for two seconds or if the THTL_EN bit is set (indicating that ACPI software is attempting throttling).

5.12.7.4 Processor-Initiated Passive Cooling (Via Programmed Duty Cycle on STPCLK#)

Using the THTL_EN and THTL_DTY bits, the ICH4 can force a programmed duty cycle on the STPCLK# signal. This reduces the effective instruction rate of the processor and cut its power consumption and heat generation.

5.12.7.5 Active Cooling

Active cooling involves fans. The GPIO signals from the ICH4 can be used to turn on/off a fan.

5.12.8 Event Input Signals and Their Usage

The ICH4 has various input signals that trigger specific events. This section describes those signals and how they should be used.

5.12.8.1 PWRBTN# - Power Button

The ICH4 PWRBTN# signal operates as a “Fixed Power Button” as described in the ACPI specification. PWRBTN# signal has a 16 ms de-bounce on the input. The state transition descriptions are included in [Table 5-44](#). Note that the transitions start as soon as the PWRBTN# is pressed (but after the debounce logic), and does not depend on when the Power Button is released.

Table 5-44. Transitions Due to Power Button

Present State	Event	Transition/Action	Comment
S0/Cx	PWRBTN# goes low	SMI# or SCI generated (depending on SCI_EN)	Software will typically initiate a Sleep state.
S1–S5	PWRBTN# goes low	Wake Event. Transitions to S0 state.	Standard wakeup
G3	PWRBTN# pressed	None	No effect since no power. Not latched nor detected.
S0–S4	PWRBTN# held low for at least 4 consecutive seconds	Unconditional transition to S5 state.	No dependence on processor (e.g., Stop-Grant cycles) or any other subsystem.

Power Button Override Function

If PWRBTN# is observed active for at least four consecutive seconds, then the state machine should unconditionally transition to the G2/S5 state, regardless of present state (S0–S4). In this case, the transition to the G2/S5 state should not depend on any particular response from the processor (e.g., a Stop-Grant cycle), nor any similar dependency from any other subsystem.

New: A power button override will force a transition to S5, even if PWROK is not active.

The PWRBTN# status is readable to check if the button is currently being pressed or has been released. The status is taken after the de-bounce, and is readable via the PWRBTN_LVL bit.

Note: The 4-second PWRBTN# assertion should only be used if a system lock-up has occurred. The 4-second timer starts counting when the ICH4 is in a S0 state. If the PWRBTN# signal is asserted and held active when the system is in a suspend state (S1–S5), the assertion causes a wake event. Once the system has resumed to the S0 state, the 4-second timer starts.

Sleep Button

The ACPI specification defines an optional Sleep button. It differs from the power button in that it only is a request to go from S0 to S1–S4 (not S5). Also, in an S5 state, the Power Button can wake the system, but the Sleep Button cannot.

Although the ICH4 does not include a specific signal designated as a Sleep Button, one of the GPIO signals can be used to create a “Control Method” Sleep Button. See the ACPI specification for implementation details.

5.12.8.2 Ring Indicate (RI#)

The Ring Indicator can cause a wake event (if enabled) from the S1–S5 states. Table 5-45 shows when the wake event is generated or ignored in different states. If in the G0/S0/Cx states, the ICH4 will generate an interrupt based on RI# active and the interrupt will be set up as a Break event.

Table 5-45. Transitions Due to RI# Signal

Present State	Event	RI_EN	Event
S0	RI# Active	X	Ignored
S1–S5	RI# Active	0 1	Ignored Wake Event

Note: Filtering/Debounce on RI# will not be done in the ICH4. It can be in modem or external.

5.12.8.3 PCI Power Management Event (PME#)

The PME# signal comes from a PCI device to request that the system be restarted. The PME# signal can generate an SMI#, SCI, or optionally a Wake event. The event occurs when the PME# signal goes from high-to-low. No event is caused when it goes from low-to-high.

In the EHCI controller, there is an internal PME_B0 bit. This is separate from the external PME# signal and can cause the same effect.

5.12.8.4 SYS_RESET# Signal

SYS_RESET# is a new pin on the ICH4 that is used to eliminate extra glue logic on the board. Before the addition of this pin, a system reset was activated by external glue forcing the PWROK signal low after the reset button was pressed. This pin eliminates the need for that glue. As such, a SYS_RESET# event should look internally to our chip and externally to the system as if PWROK had gone low.

When the SYS_RESET# pin is detected as active after the 16 ms debounce logic, the ICH4 attempts to perform a “graceful” reset, by waiting up to 25 ms for the SMBus to go idle. If the SMBus is idle when the pin is detected active, the reset occurs immediately, otherwise the counter starts. If at any point during the count the SMBus goes idle, the reset occurs. If, however, the counter expires and the SMBus is still active, a reset is forced upon the system even though activity is still occurring.

Once a reset of this type has occurred, it cannot occur again until SYS_RESET# has been detected inactive after the debounce logic, and the system is back to a full S0 state as indicated by all of the PWROK inputs being active.

5.12.8.5 THRMTRIP# Signal

If THRMTRIP# goes active, the processor is indicating an overheat condition, and the ICH4 immediately transitions to an S5 state. However, since the processor has overheated, it does not respond to the ICH4's STPCLK# pin with a stop grant special cycle. Therefore, the ICH4 does not wait for one. Immediately upon seeing THRMTRIP# low, the ICH4 initiates a transition to the S5 state, drives SLP_S3#, SLP_S4#, SLP_S5# low, and sets the CTS bit. The transition looks like a power button override.

It is extremely important that when a THRMTRIP# event occurs, the ICH4 power down immediately without following the normal S0 -> S5 path. This path may be taken in parallel, but ICH4 must immediately enter a power down state. It will do this by driving SLP_S3#, SLP_S4#, and SLP_S5# immediately after sampling THRMTRIP# active.

If the processor is running extremely hot and is heating up, it is possible (although very unlikely) that components around it (e.g., the ICH4, are no longer executing cycles properly). Therefore, if THRMTRIP# fires, and the ICH4 is relying on state machine logic to perform the power down, the state machine may not be working, and the system will not power down.

The ICH4 follows this flow for THRMTRIP#.

1. At boot (PCIRST# low), THRMTRIP# ignored.
2. After power-up (PCIRST# high), if THRMTRIP# sampled active, SLP_S3#, SLP_S4#, and SLP_S5# fire, and normal sequence of sleep machine starts.
3. Until sleep machine enters the S5 state, SLP_S3#, SLP_S4#, and SLP_S5# stay active, even if THRMTRIP# is now inactive. This is the equivalent of "latching" the thermal trip event.
4. If S5 state reached, go to step #1, otherwise stay here. If the ICH4 never reaches S5, ICH4 will not reboot until power is cycled.

5.12.9 ALT Access Mode

Before entering a low power state, several registers from powered down parts may need to be saved. In the majority of cases, this is not an issue, as registers have read and write paths. However, several of the ISA compatible registers are either read only or write only. To get data out of write-only registers, and to restore data into read-only registers, the ICH4 implements an ALT access mode.

If the ALT access mode is entered and exited after reading the registers of the ICH4 timer (8254), the timer starts counting faster (13.5 ms). The following steps listed below can cause problems:

- BIOS enters ALT access mode for reading the ICH4 timer related registers.
- BIOS exits ALT access mode.
- BIOS continues through the execution of other needed steps and passes control to the OS.

After getting control in step #3, if the OS does not reprogram the system timer again, the timer ticks may be happening faster than expected. For example DOS and its associated software assume that the system timer is running at 54.6 ms and as a result the timeouts in the software may be happening faster than expected.

Operating systems (e.g., Microsoft Windows* 98, Windows* 2000 and Windows NT*) reprogram the system timer and, therefore, will not run into this problem.

For other operating systems (e.g., MS-DOS) the BIOS should restore the timer back to 54.6 ms before passing control to the OS. If the BIOS is entering ALT access mode before entering the suspend state it is not necessary to restore the timer contents after the exit from ALT access mode.

5.12.9.1 Write Only Registers with Read Paths in ALT Access Mode

The registers described in Table 5-46 have read paths in ALT access mode. The access number field in the table indicates which register will be returned per access to that port.

Table 5-46. Write Only Registers with Read Paths in ALT Access Mode (Sheet 1 of 2)

Restore Data				Restore Data			
I/O Addr	# of Rds	Access	Data	I/O Addr	# of Rds	Access	Data
00h	2	1	DMA Chan 0 base address low byte	40h	7	1	Timer Counter 0 status, bits [5:0]
		2	DMA Chan 0 base address high byte			2	Timer Counter 0 base count low byte
01h	2	1	DMA Chan 0 base count low byte			3	Timer Counter 0 base count high byte
		2	DMA Chan 0 base count high byte			4	Timer Counter 1 base count low byte
02h	2	1	DMA Chan 1 base address low byte			5	Timer Counter 1 base count high byte
		2	DMA Chan 1 base address high byte			6	Timer Counter 2 base count low byte
03h	2	1	DMA Chan 1 base count low byte			7	Timer Counter 2 base count high byte
		2	DMA Chan 1 base count high byte	41h	1	Timer Counter 1 status, bits [5:0]	
04h	2	1	DMA Chan 2 base address low byte	42h	1	Timer Counter 2 status, bits [5:0]	
		2	DMA Chan 2 base address high byte	70h	1	Bit 7 = NMI Enable, Bits [6:0] = RTC Address	
05h	2	1	DMA Chan 2 base count low byte	C4h	2	1	DMA Chan 5 base address low byte
		2	DMA Chan 2 base count high byte			2	DMA Chan 5 base address high byte
06h	2	1	DMA Chan 3 base address low byte	C6h	2	1	DMA Chan 5 base count low byte
		2	DMA Chan 3 base address high byte			2	DMA Chan 5 base count high byte
07h	2	1	DMA Chan 3 base count low byte	C8h	2	1	DMA Chan 6 base address low byte
		2	DMA Chan 3 base count high byte			2	DMA Chan 6 base address high byte
08h	6	1	DMA Chan 0–3 Command ²	CAh	2	1	DMA Chan 6 base count low byte
		2	DMA Chan 0–3 Request			2	DMA Chan 6 base count high byte
		3	DMA Chan 0 Mode: Bits(1:0) = "00"	CCh	2	1	DMA Chan 7 base address low byte
		4	DMA Chan 1 Mode: Bits(1:0) = "01"			2	DMA Chan 7 base address high byte
		5	DMA Chan 2 Mode: Bits(1:0) = "10"	CEh	2	1	DMA Chan 7 base count low byte
		6	DMA Chan 3 Mode: Bits(1:0) = "11"			2	DMA Chan 7 base count high byte

Table 5-46. Write Only Registers with Read Paths in ALT Access Mode (Sheet 2 of 2)

Restore Data				Restore Data			
I/O Addr	# of Rds	Access	Data	I/O Addr	# of Rds	Access	Data
20h	12	1	PIC ICW2 of Master controller	D0h	6	1	DMA Chan 4–7 Command ²
		2	PIC ICW3 of Master controller			2	DMA Chan 4–7 Request
		3	PIC ICW4 of Master controller			3	DMA Chan 4 Mode: Bits(1:0) = 00
		4	PIC OCW1 of Master controller ¹			4	DMA Chan 5 Mode: Bits(1:0) = 01
		5	PIC OCW2 of Master controller			5	DMA Chan 6 Mode: Bits(1:0) = 10
		6	PIC OCW3 of Master controller			6	DMA Chan 7 Mode: Bits(1:0) = 11.
		7	PIC ICW2 of Slave controller				
		8	PIC ICW3 of Slave controller				
		9	PIC ICW4 of Slave controller				
		10	PIC OCW1 of Slave controller ¹				
		11	PIC OCW2 of Slave controller				
		12	PIC OCW3 of Slave controller				

NOTES:

1. The OCW1 register must be read before entering ALT access mode.
2. Bits 5, 3, 1, and 0 return 0.

5.12.9.2 PIC Reserved Bits

Many bits within the PIC are reserved, and must have certain values written in order for the PIC to operate properly. Therefore, there is no need to return these values in ALT access mode. When reading PIC registers from 20h and A0h, the reserved bits shall return the values listed in Table 5-47.

Table 5-47. PIC Reserved Bits Return Values

PIC Reserved Bits	Value Returned
ICW2[2:0]	000
ICW4[7:5]	000
ICW4[3:2]	00
ICW4[0]	0
OCW2[4:3]	00
OCW3[7]	0
OCW3[5]	Reflects bit 6
OCW3[4:3]	01

5.12.9.3 Read Only Registers with Write Paths in ALT Access Mode

The registers described in Table 5-48 have write paths to them in ALT access mode. Software restores these values after returning from a powered down state. These registers must be handled special by software. When in normal mode, writing to the base address/count register also writes to the current address/count register. Therefore, the base address/count must be written first, then the part is put into ALT access mode and the current address/count register is written.

Table 5-48. Register Write Accesses in ALT Access Mode

I/O Address	Register Write Value
08h	DMA Status Register for channels 0–3.
D0h	DMA Status Register for channels 4–7.

5.12.10 System Power Supplies, Planes, and Signals

5.12.10.1 Power Plane Control with SLP_S3#, SLP_S4# and SLP_S5#

The SLP_S3# output signal can be used to cut power to the system core supply, since it only goes active for the STR state (typically mapped to ACPI S3). Power must be maintained to the ICH4 resume well, and to any other circuits that need to generate Wake signals from the STR state.

Cutting power to the core may be done via the power supply, or by external FETs to the motherboard. The SLP_S4# or SLP_S5# output signal can be used to cut power to the system core supply, as well as power to the system memory, since the context of the system is saved on the disk. Cutting power to the memory may be done via the power supply, or by external FETs to the motherboard.

5.12.10.2 PWROK Signal

The PWROK input should go active based on the core supply voltages becoming valid. PWROK should go active no sooner than 10 ms after Vcc3_3 and Vcc1_5 have reached their nominal values.

Note:

1. Traditional designs have a reset button logically ANDs with the PWROK signal from the power supply and the processor's voltage regulator module. If this is done with the ICH4, the PWROK_FLR bit will be set. The ICH4 treats this internally as if the RSMRST# signal had gone active. However, it is not treated as a full power failure. If PWROK goes inactive and then active (but RSMRST# stays high), then the ICH4 will reboot (regardless of the state of the AFTERG3 bit). If the RSMRST# signal also goes low before PWROK goes high, then this is a full power failure, and the reboot policy is controlled by the AFTERG3 bit.
2. PWROK and RSMRST# are sampled using the RTC clock. Therefore, low times that are less than one RTC clock period may not be detected by the ICH4.
3. In the case of true PWROK failure, PWROK will go low first before the VRMPWRGD.

5.12.10.3 VRMPWRGD Signal

This signal is connected to the processor's VRM and is internally AND'd with the PWROK signal that comes from the system power supply. This saves the external AND gate found in desktop systems.

5.12.10.4 Controlling Leakage and Power Consumption during Low-Power States

To control leakage in the system, various signals tri-state or go low during some low-power states.

General principles:

- All signals going to powered down planes (either internally or externally) must be either tri-stated or driven low.
- Signals with pull-up resistors should not be low during low-power states. This is to avoid the power consumed in the pull-up resistor.
- Buses should be halted (and held) in a known state to avoid a floating input (perhaps to some other device). Floating inputs can cause extra power consumption.

Based on the above principles, the following measures are taken:

- During S3 (STR), all signals attached to powered down planes will be tri-stated or driven low.

5.12.11 Clock Generators

The clock generator is expected to provide the frequencies shown in [Table 5-49](#).

Table 5-49. Intel® ICH4 Clock Inputs

Clock Domain	Frequency	Source	Usage
CLK66	66 MHz	Main Clock Generator	Should be running in all Cx states. Stopped in S3 ~ S5 based on SLP_S3# assertion.
PCICLK	33 MHz	Main Clock Generator	Free-running PCI Clock to ICH4. Stopped in S3 ~ S5 based on SLP_S3# assertion.
CLK48	48 MHz	Main Clock Generator	Used by USB controllers. Stopped in S3 ~ S5 based on SLP_S3# assertion.
CLK14	14.318 MHz	Main Clock Generator	Used by ACPI timers. Stopped in S3 ~ S5 based on SLP_S3# assertion.
AC_BIT_CLK	12.288 MHz	AC '97 Codec	AC-link. Control policy is determined by the clock source.
APICCLK	16.67 MHz or 33 MHz	Main Clock Generator	Used for ICH4-processor interrupt messages. Should be running in C0, C1 and C2. Stopped in S3 ~ S5 based on SLP_S3# assertion.
LAN_CLK	0.8 to 50 MHz	LAN Connect	LAN Connect link. Control policy is determined by the clock source.

5.12.12 Legacy Power Management Theory of Operation

Instead of relying on ACPI software, legacy power management uses BIOS and various hardware mechanisms. ICH4 has a greatly simplified method for legacy power management compared with previous generations (e.g., the PIIX4).

The scheme relies on the concept of detecting when individual subsystems are idle, detecting when the whole system is idle, and detecting when accesses are attempted to idle subsystems.

However, the OS is assumed to be at least APM enabled. Without APM calls, there is no quick way to know when the system is idle between keystrokes. The ICH4 does not support the burst modes found in previous components (e.g., the PIIX4).

5.12.12.1 Desktop APM Power Management

The ICH4 has a timer that, when enabled by the 1MIN_EN bit in the SMI Control and Enable register, generates an SMI# once per minute. The SMI handler can check for system activity by reading the DEVACT_STS register. If none of the system bits are set, the SMI handler can increment a software counter. When the counter reaches a sufficient number of consecutive minutes with no activity, the SMI handler can then put the system into a lower power state.

If there is activity, various bits in the DEVACT_STS register will be set. Software clears the bits by writing a 1 to the bit position.

The DEVACT_STS register allows for monitoring various internal devices, or Super I/O devices (SP, PP, FDC) on LPC or PCI, keyboard controller accesses, or audio functions on LPC or PCI. Other PCI activity can be monitored by checking the PCI interrupts.

5.13 System Management (D31:F0)

The ICH4 provides various functions to make a system easier to manage and to lower the Total Cost of Ownership (TCO) of the system. Features and functions can be augmented via external A/D converters and GPIO, as well as an external microcontroller.

The following features and functions are supported by the ICH4:

- Processor present detection
 - Detects if processor fails to fetch the first instruction after reset
- Various Error detection (e.g., ECC Errors) Indicated by Host controller
 - Can generate SMI#, SCI, SERR, NMI, or TCO interrupt
- Intruder Detect input
 - Can generate TCO interrupt or SMI# when the system cover is remove
 - INTRUDER# allowed to go active in any power state, including G3
- Detection of bad FWH programming
 - Detects if data on first read is FFh (indicates unprogrammed FWH)
- Ability to hide a PCI device
 - Allows software to hide a PCI device in terms of configuration space through the use of a device hide register (See [Section 8.1.26](#))

Note: Voltage ID from the processor can be read via GPI signals.

5.13.1 Theory of Operation

The System Management functions are designed to allow the system to diagnose failing subsystems. The intent of this logic is that some of the system management functionality be provided without the aid of an external microcontroller.

5.13.1.1 Detecting a System Lockup

When the processor is reset, it is expected to fetch its first instruction. If the processor fails to fetch the first instruction after reset, the TCO timer times out twice and the ICH4 asserts PCIRST#.

5.13.1.2 Handling an Intruder

The ICH4 has an input signal, INTRUDER#, that can be attached to a switch that is activated by the system's case being open. This input has a two RTC clock debounce. If INTRUDER# goes active (after the debouncer), this will set the INTRD_DET bit in the TCO_STS register. The INTRD_SEL bits in the TCO_CNT register can enable the ICH4 to cause an SMI# or interrupt. The BIOS or interrupt handler can then cause a transition to the S5 state by writing to the SLP_EN bit.

The software can also directly read the status of the INTRUDER# signal (high or low) by clearing and then reading the INTRD_DET bit. This allows the signal to be used as a GPI if the intruder function is not required.

If the INTRUDER# signal goes inactive some point after the INTRD_DET bit is written as a 1, then the INTRD_DET signal will go to a 0 when INTRUDER# input signal goes inactive. Note that this is slightly different than a classic sticky bit, since most sticky bits would remain active indefinitely when the signal goes active and would immediately go inactive when a 1 is written to the bit.

Note: The INTRD_DET bit resides in the ICH4's RTC well, and is set and cleared synchronously with the RTC clock. Thus, when software attempts to clear INTRD_DET (by writing a 1 to the bit location) there may be as much as two RTC clocks (about 65 μ s) delay before the bit is actually cleared. Also, the INTRUDER# signal should be asserted for a minimum of 1 ms to guarantee that the INTRD_DET bit will be set.

Note: If the INTRUDER# signal is still active when software attempts to clear the INTRD_DET bit, the bit will remain set and the SMI will be generated again immediately. The SMI handler can clear the INTRD_SEL bits to avoid further SMIs. However, if the INTRUDER# signal goes inactive and then active again, there will not be further SMIs, since the INTRD_SEL bits would select that no SMI# be generated.

5.13.1.3 Detecting Improper FWH Programming

The ICH4 can detect the case where the FWH is not programmed. This results in the first instruction fetched to have a value of FFh. If this occurs, the ICH4 sets the BAD_BIOS bit, which can then be reported via the Heartbeat and Event reporting using an external, Alert on LAN enabled LAN controller (See [Section 5.13.2](#)).

5.13.1.4 Handling an ECC Error or Other Memory Error

The Host controller provides a message to indicate that it would like to cause an SMI#, SCI, SERR#, or NMI. The software must check the Host controller as to the exact cause of the error.

5.13.2 Alert on LAN*

The ICH4 integrated LAN controller supports Alert on LAN functionality when used with the 82562EM Platform LAN Connect component. This allows the integrated LAN controller to report messages to a network management console without the aid of the system processor. This is crucial in cases where the processor is malfunctioning or cannot function due to being in a low-power state.

The ICH4 also features an independent, dedicated SMBus interface, referred to as the SMLINK interface that can be used with an external Alert on LAN (or Alert on LAN 2) enabled LAN controller. This separate interface is required, since devices on the system SMBus will be powered down during some low power states.

The basic scheme is for the ICH4 integrated LAN controller to send a prepared Ethernet message to a network management console. The prepared message is stored in the non-volatile EEPROM that is connected to the ICH4.

Messages will be sent by the LAN controller either because a specific event has occurred, or they will be sent periodically (also known as a heartbeat). The event and heartbeat messages have the exact same format. The event messages are sent based on events occurring. The heartbeat messages is sent every 30 to 32 seconds. When an event occurs, the ICH4 sends a new message and increments the SEQ[3:0] field. For heartbeat messages, the sequence number does not increment.

The following rules/steps apply if the system is in a G0 state and the policy is for the ICH4 to **reboot** the system after a hardware lockup:

1. Upon detecting the lockup the SECOND_TO_STS bit will be set. The ICH4 may send up to 1 Event message to the D110. The ICH4 then attempts to reboot the processor.
2. If the reboot at step 1 is successful, BIOS should clear the SECOND_TO_STS bit. This prevents any further Heartbeats from being sent. The BIOS may then perform addition recovery/boot steps. (See note 2.)
3. If the reboot attempt in step 1 is not successful, then the timer will timeout a third time. At this point the system has locked up and was unsuccessful in rebooting. The ICH4 does not attempt to automatically reboot again. The ICH4 starts sending a message every heartbeat period (30–32 seconds). The heartbeats continue until some external intervention occurs (reset, power failure, etc.).
4. After step 3 (unsuccessful reboot after third timeout), if the user does a Power Button Override, the system goes to an S5 state. The ICH4 continues sending the messages every heartbeat period.
5. After step 4 (power button override after unsuccessful reboot) if the user presses the Power Button again, the system should wake to an S0 state and the processor should start executing the BIOS.
6. If step 5 (power button press) is successful in waking the system, the ICH4 continues sending messages every heartbeat period until the BIOS clears the SECOND_TO_STS bit. (See note 2)
7. If step 5 (power button press) is unsuccessful in waking the system, the ICH4 continues sending a message every heartbeat period. The ICH4 does not attempt to automatically reboot again. The ICH4 will start sending a message every heartbeat period (30–32 seconds). The heartbeats continue until some external intervention occurs (reset, power failure, etc.). (See note 3)
8. After step 3 (unsuccessful reboot after third timeout), if a reset is attempted (using a button that pulses PWROK low or via the message on the SMBus slave interface), the ICH4 attempts to reset the system.
9. After step 8 (reset attempt) if the reset is successful, BIOS is run. The ICH4 continues sending a message every heartbeat period until the BIOS clears the SECOND_TO_STS bit. (See note 2)
10. After step 8 (reset attempt), if the reset is unsuccessful, then the ICH4 continues sending a message every heartbeat period. The ICH4 does not attempt to reboot the system again without external intervention. (See note 3)

The following rules/steps apply if the system is in a G0 state and the policy is for the ICH4 to **not reboot** the system after a hardware lockup.

1. Upon detecting the lockup the SECOND_TO_STS bit is set. The ICH4 sends a message with the Watchdog (WD) Event status bit set (and any other bits that must also be set). This message is sent as soon as the lockup is detected, and is sent with the next (incremented) sequence number.
2. After step 1, the ICH4 sends a message every heartbeat period until some external intervention occurs.
3. Rules/steps 4–10 apply if no user intervention (resets, power button presses, SMBus reset messages) occur after a third timeout of the watchdog timer. If the intervention occurs before the third timeout, then jump to rule/step11.
4. After step 3 (third timeout), if the user does a Power Button Override, the system goes to an S5 state. The ICH4 continues sending heartbeats at this point.

5. After step 4 (power button override), if the user presses the power button again, the system should wake to an S0 state and the processor should start executing the BIOS.
6. If step 5 (power button press) is successful in waking the system, the ICH4 continues sending heartbeats until the BIOS clears the SECOND_TO_STS bit. (See note 2)
7. If step 5 (power button press) is unsuccessful in waking the system, the ICH4 continues sending heartbeats. The ICH4 does not attempt to reboot the system again until some external intervention occurs (reset, power failure, etc.). (See note 3)
8. After step 3 (3rd timeout), if a reset is attempted (using a button that pulses PWROK low or via the message on the SMBus slave interface), the ICH4 attempts to reset the system.
9. If step 8 (reset attempt) is successful, then the BIOS will be run. The ICH4 continues sending heartbeats until the BIOS clears the SECOND_TO_STS bit. (See note 2)
10. If step 8 (reset attempt), is unsuccessful, the ICH4 continues sending heartbeats. The ICH4 does not attempt to reboot the system again without external intervention. **Note:** A system that has locked up and can not be restarted with power button press is probably broken (bad power supply, short circuit on some bus, etc.).
11. This and the following rules/steps apply if the user intervention (power button press, reset, SMBus message, etc.) occur prior to the third timeout of the watchdog timer.
12. After step 1 (second timeout), if the user does a Power Button Override, the system goes to an S5 state. The ICH4 continues sending heartbeats at this point.
13. After step 12 (power button override), if the user presses the power button again, the system should wake to an S0 state and the processor should start executing the BIOS.
14. If step 13 (power button press) is successful in waking the system, the ICH4 will continue sending heartbeats until the BIOS clears the SECOND_TO_STS bit. (See note 2)
15. If step 13 (power button press) is unsuccessful in waking the system, the ICH4 will continue sending heartbeats. The ICH4 will not attempt to reboot the system again until some external intervention occurs (reset, power failure, etc.). (See note 3)
16. After step 1 (second timeout), if a reset is attempted (using a button that pulses PWROK low or via the message on the SMBus slave interface), the ICH4 will attempt to reset the system.
17. If step 16 (reset attempt) is successful, then the BIOS will be run. The ICH4 will continue sending heartbeats until the BIOS clears the SECOND_TO_STS bit. (See note 2)
18. If step 16 (reset attempt), is unsuccessful, then the ICH4 will continue sending heartbeats. The ICH4 will not attempt to reboot the system again without external intervention. (See note 3)

If the system is in a G1 (S1–S4) state, the ICH4 will send a heartbeat message every 30–32 seconds. If an event occurs prior to the system being shutdown, the ICH4 will immediately send an event message with the next incremented sequence number. After the event message, the ICH4 will resume sending heartbeat messages.

Note: Notes for Previous two numbered lists.

1. Normally, the ICH4 does not send heartbeat messages while in the G0 state (except in the case of a lockup). However, if a hardware event (or heartbeat) occurs just as the system is transitioning into a G0 state, the hardware will continue to send the message even though the system will be in a G0 state (and the status bits may indicate this).

When used with an external Alert on LAN enabled LAN controller, the ICH4 sends these messages via the SMLINK signals. When sending messages via these signals, the ICH4 abides by the SMBus rules associated with collision detection. It delays starting a message until the bus is idle, and will detect collisions. If a collision is detected, the ICH4 waits until the bus is idle and tries again.

2. **WARNING:** It is important that the BIOS clears the SECOND_TO_STS bit, as the alerts will interfere with the LAN device driver from working properly. The alerts reset part of the D110 and would prevent an operating system's device driver from sending or receiving some messages.
3. A system that has locked up and can not be restarted with power button press is assumed to have broken hardware (bad power supply, short circuit on some bus, etc.), and is beyond ICH4's recovery mechanisms.
4. A spurious alert could occur in the following sequence:
 - The processor has initiated an alert using the SEND_NOW bit.
 - During the alert, the THRM#, INTRUDER# or GPI[11] changes state.
 - The system then goes to a non-S0 state.

Once the system transitions to the non-S0 state, it may send a single alert with an incremental SEQUENCE number.

5. An inaccurate alert message can be generated in the following scenario.
 - The system successfully boots after a second watchdog Timeout occurs.
 - PWROK goes low (typically, due to a reset button press) or a power button override occurs (before the SECOND_TO_STS bit is cleared).
 - An alert message indicating that the processor is missing or locked up is generated with a new sequence number.

Table 5-50 shows the data included in the Alert on LAN messages.

Table 5-50. Alert on LAN* Message Data

Field	Comment
Cover Tamper Status	1 = This bit will be set if the intruder detect bit is set (INTRD_DET).
Temp Event Status	1 = This bit will be set if the ICH4THERM# input signal is asserted.
Processor Missing Event Status	1 = This bit will be set if the processor failed to fetch the first instruction.
TCO Timer Event Status	1 = This bit is set when the TCO timer expires.
Software Event Status	1 = This bit is set when software writes a 1 to the SEND_NOW bit.
Unprogrammed FWH Event Status	1 = First BIOS fetch returned a value of FFh, indicating that the FWH has not yet been programmed (still erased).
GPIO Status	1 = This bit is set when GPIO[11] signal is high. 0 = This bit is cleared when GPIO[11] signal is low. An event message is triggered on a transition of GPIO[11].
SEQ[3:0]	This is a sequence number. It is initially 0, and increments each time the Intel® ICH4 sends a new message. Upon reaching 1111, the sequence number rolls over to 0000. MSB (SEQ3) sent first.
System Power State	00 = G0, 01 = G1, 10 = G2, 11 = Pre-Boot. MSB sent first
MESSAGE1	Will be the same as the MESSAGE1 Register. MSB sent first.
MESSAGE2	Will be the same as the MESSAGE2 Register. MSB sent first.
WDSTATUS	Will be the same as the WDSTATUS Register. MSB sent first.

5.14 General Purpose I/O

5.14.1 GPIO Mapping

Table 5-51. GPIO Implementation (Sheet 1 of 2)

GPIO	Type	Alternate Function ⁽¹⁾	Power Well	Tolerant	Notes
GPI[0]	Input Only	REQ[A]#	Core	5.0 V	<ul style="list-style-type: none"> GPIO_USE_SEL bit 0 enables REQ/GNT[A]# pair. Input active status read from GPE0_STS register bit 0. Input active high/low set through GPI_INV register bit 0.
GPI[1]	Input Only	REQ[B]# or REQ[5]#	Core	5.0 V	<ul style="list-style-type: none"> GPIO_USE_SEL bit 1 enables REQ/GNT[B]# pair ⁽³⁾. Input active status read from GPE0_STS register bit 1. Input active high/low set through GPI_INV register bit 1.
GPI[2:5]	Input Only	PIRQ[E:H]#	Core	5.0 V	<ul style="list-style-type: none"> GPIO_USE_SEL bits [2:5] enable PIRQ[E:H]#. Input active status read from GPE0_STS register bits [2:5]. Input active high/low set through GPI_INV register bits [2:5].
GPI[6]	Input Only		Core	5.0 V	<ul style="list-style-type: none"> Input active status read from GPE0_STS register bit 6. Input active high/low set through GPI_INV register bit 6.
GPI[7]	Input Only	Unmuxed	Core	5.0 V	<ul style="list-style-type: none"> Input active status read from GPE0_STS register bit 7. Input active high/low set through GPI_INV register bit 7.
GPI[8]	Input Only	Unmuxed	Resume	3.3 V	<ul style="list-style-type: none"> Input active status read from GPE0_STS register bit 8. Input active high/low set through GPI_INV register bit 8.
GPI[9:10]	N/A	N/A	N/A		<ul style="list-style-type: none"> Not implemented
GPI[11]	Input Only	SMBALERT#	Resume	3.3 V	<ul style="list-style-type: none"> GPIO_USE_SEL bit 11 enables SMBALERT#. Input active status read from GPE0_STS register bit 11. Input active high/low set through GPI_INV register bit 11.
GPI[12]	Input Only	Unmuxed	Resume	3.3 V	<ul style="list-style-type: none"> Input active status read from GPE0_STS register bit 12. Input active high/low set through GPI_INV register bit 12.
GPI[13]	Input Only	Unmuxed	Resume	3.3 V	<ul style="list-style-type: none"> Input active status read from GPE0_STS register bit 13. Input active high/low set through GPI_INV register bit 13.
GPI[14:15]	N/A	N/A	N/A		<ul style="list-style-type: none"> Not Implemented

Table 5-51. GPIO Implementation (Sheet 2 of 2)

GPIO	Type	Alternate Function ⁽¹⁾	Power Well	Tolerant	Notes
GPO[16]	Output Only	GNT[A]#	Core	3.3 V	<ul style="list-style-type: none"> Output controlled via GP_LVL register bit 16. TTL driver output
GPO[17]	Output Only	GNT[B]# or GNT[5]#	Core	3.3 V	<ul style="list-style-type: none"> Output controlled via GP_LVL register bit 17. TTL driver output
GPO[18]	Output Only	N/A	Core	3.3 V	<ul style="list-style-type: none"> Output controlled via GP_LVL register bits [18:19]. TTL driver output
GPO[19]	Output Only	N/A	Core	3.3 V	<ul style="list-style-type: none"> Output controlled via GP_LVL register bits [18:19]. TTL driver output
GPO[20]	Output Only	N/A	Core	3.3 V	<ul style="list-style-type: none"> Output controlled via GP_LVL register bit 20. TTL driver output
GPO[21]	Output Only	N/A	Core	3.3 V	<ul style="list-style-type: none"> This GPO defaults high. Output controlled via GP_LVL register bit 21. TTL driver output
GPO[22]	Output Only	N/A	Core	3.3 V	<ul style="list-style-type: none"> Output controlled via GP_LVL register bit [22]. Open-drain output
GPIO[23]	Output Only	N/A	Core	3.3 V	<ul style="list-style-type: none"> Output controlled via GP_LVL register bit [23]. TTL driver output
GPIO[24]	I/O	N/A	Resume	3.3 V	<ul style="list-style-type: none"> Input active status read from GP_LVL register bit 24. Output controlled via GP_LVL register bit 24. TTL driver output
GPIO[25]	I/O	Unmuxed	Resume	3.3 V	<ul style="list-style-type: none"> Blink enabled via GPO_BLINK register bit 25. Input active status read from GP_LVL register bit 25 Output controlled via GP_LVL register bit 25. TTL driver output
GPIO[26]	N/A	N/A	N/A		<ul style="list-style-type: none"> Not implemented
GPIO[27:28]	I/O	Unmuxed	Resume	3.3 V	<ul style="list-style-type: none"> Input active status read from GP_LVL register bits [27:28] Output controlled via GP_LVL register bits [27:28] TTL driver output
GPIO[29:31]	N/A	N/A	N/A		<ul style="list-style-type: none"> Not implemented
GPIO[32:43]	I/O	Unmuxed	Core	3.3 V	

NOTES:

- All GPIOs default to their alternate function.
- All inputs are sticky. The status bit remains set as long as the input was asserted for 2 clocks. GPIs are sampled on PCI clocks in S0/S1. GPIs are sampled on RTC clocks in S3/S4/S5.
- GPIO[0:7] are 5 V tolerant, and all GPIs can be routed to cause an SCI or SMI#.
- If GPIO_USE_SEL bit 1 is set to 1 and GEN_CNT bit 25 is also set to 1 then REQ/GNT[5]# is enabled. See [Section 9.1.22](#).

5.14.2 Power Wells

Some GPIOs exist in the resume power plane. Care must be taken to make sure GPIO signals are not driven high into powered-down planes.

Some ICH4 GPIOs may be connected to pins on devices that exist in the core well. If these GPIOs are outputs, there is a danger that a loss of core power (PWROK low) or a Power Button Override event will result in the ICH4 driving a pin to a logic 1 to another device that is powered down.

GPIO[1:15] have “sticky” bits on the input. Refer to the GPE0_STS register. As long as the signal goes active for at least 2 clocks, the ICH4 will keep the sticky status bit active. The active level can be selected in the GP_LVL register.

If the system is in an S0 or an S1 state, the GPI inputs are sampled at 33 MHz, so the signal only needs to be active for about 60 ns to be latched. In the S3–S5 states, the GPI inputs are sampled at 32.768 kHz, and thus must be active for at least 61 microseconds to be latched.

If the input signal is still active when the latch is cleared, it will again be set. Another edge trigger is not required. This makes these signals “level” triggered inputs.

5.14.3 SMI# and SCI Routing

The routing bits for GPIO[0:15] allow an input to be routed to SMI# or SCI, or neither. Note that a bit can be routed to either an SMI# or an SCI, but not both.

5.15 IDE Controller (D31:F1)

The ICH4 IDE controller features two sets of interface signals (Primary and Secondary) that can be independently enabled, tri-stated or driven low. The ICH4 IDE controller supports both legacy mode and native mode IDE interface. In native mode, the IDE controller is a fully PCI compliant software interface and does not use any legacy I/O or interrupt resources. The IDE interfaces of the ICH4 can support several types of data transfers:

- **Programmed I/O (PIO):** Processor is in control of the data transfer.
- **8237 style DMA:** DMA protocol that resembles the DMA on the ISA bus, although it does not use the 8237 in the ICH4. This protocol off loads the processor from moving data. This allows higher transfer rate of up to 16 MB/s.
- **Ultra ATA/33:** DMA protocol that redefines signals on the IDE cable to allow both host and target throttling of data and transfer rates of up to 33 MB/s.
- **Ultra ATA/66:** DMA protocol that redefines signals on the IDE cable to allow both host and target throttling of data and transfer rates of up to 66 MB/s.
- **Ultra ATA/100:** DMA protocol that redefines signals on the IDE cable to allow both host and target throttling of data and transfer rates of up to 100 MB/s.

5.15.1 PIO Transfers

The ICH4 IDE controller includes both compatible and fast timing modes. The fast timing modes can be enabled only for the IDE data ports. All other transactions to the IDE registers are run in single transaction mode with compatible timings.

Up to two IDE devices may be attached per IDE connector (drive 0 and drive 1). The IDETIM and SIDETIM Registers permit different timing modes to be programmed for drive 0 and drive 1 of the same connector.

The Ultra ATA/33/66/100 synchronous DMA timing modes can also be applied to each drive by programming the IDE I/O Configuration register and the Synchronous DMA Control and Timing registers. When a drive is enabled for synchronous DMA mode operation, the DMA transfers are executed with the synchronous DMA timings. The PIO transfers are executed using compatible timings or fast timings if also enabled.

5.15.1.1 IDE Port Decode

The Command and Control Block registers are accessed differently depending on the decode mode, which is selected by the Programming Interface configuration register (Offset 09h).

Note: The primary and secondary channels are controlled by separate bits, allowing one to be in native mode and the other in legacy mode simultaneously.

5.15.1.2 IDE Legacy Mode and Native Mode

The ICH4 IDE controller supports both legacy mode and PCI native mode. In legacy mode, the Command and Control Block registers are accessible at fixed I/O addresses. While in legacy mode, the ICH4 does not decode any of the native mode ranges. Likewise, in native mode the ICH4 does not decode any of the legacy mode ranges.

The IDE I/O ports involved in PIO transfers are decoded by the ICH4 to the IDE interface when D31:F1 I/O space is enabled and IDE decode is enabled through the IDE_TIMx registers. The IDE registers are implemented in the drive itself. An access to the IDE registers results in the assertion of the appropriate IDE chip select for the register, and the IDE command strobes (PDIOR#/SDIOR#, PDIOW#/SDIOW#).

There are two I/O ranges for each IDE cable: the Command Block, which corresponds to the PCS1#/SCS1# chip select, and the Control Block, which corresponds to the PCS3#/SCS3# chip select. The Command Block is an 8-byte range, while the control block is a 4-byte range.

- **Command Block Offset:** 01F0h for primary, 0170h for secondary
- **Control Block Offset:** 03F4h for primary, 0374h for secondary

[Table 5-52](#) and [Table 5-53](#) specify the registers as they affect the ICH4 hardware definition.

Note: The Data Register (I/O Offset 00h) should be accessed using 16-bit or 32-bit I/O instructions. All other registers should be accessed using 8-bit I/O instructions.

Table 5-52. IDE Legacy I/O Ports: Command Block Registers (CS1x# Chip Select)

I/O Offset	Register Function (Read)	Register Function (Write)
00h	Data	Data
01h	Error	Features
02h	Sector Count	Sector Count
03h	Sector Number	Sector Number
04h	Cylinder Low	Cylinder Low
05h	Cylinder High	Cylinder High
06h	Drive	Head
07h	Status	Command

NOTE: For accesses to the Alt Status register in the Control Block, the ICH4 must always force the upper address bit (PDA[2] or SDA[2]) to 1 in order to guarantee proper native mode decode by the IDE device. Unlike the legacy mode fixed address location, the native mode address for this register may contain a 0 in address bit 2 when it is received by the ICH4.

In native mode, the ICH4 does not decode the legacy ranges. The same offsets are used as in [Table 5-52](#) and [Table 5-53](#) above. However, the base addresses are selected using the PCI BARs, rather than fixed I/O locations.

5.15.1.3 PIO IDE Timing Modes

IDE data port transaction latency consists of startup latency, cycle latency, and shutdown latency. Startup latency is incurred when a PCI master cycle targeting the IDE data port is decoded and the DA[2:0] and CSxx# lines are not set up. Startup latency provides the setup time for the DA[2:0] and CSxx# lines prior to assertion of the read and write strobes (DIOR# and DIOW#).

Cycle latency consists of the I/O command strobe assertion length and recovery time. Recovery time is provided so that transactions may occur back-to-back on the IDE interface (without incurring startup and shutdown latency) without violating minimum cycle periods for the IDE interface. The command strobe assertion width for the enhanced timing mode is selected by the IDE_TIM Register and may be set to 2, 3, 4, or 5 PCI clocks. The recovery time is selected by the IDE_TIM Register and may be set to 1, 2, 3, or 4 PCI clocks.

If IORDY is asserted when the initial sample point is reached, no wait-states are added to the command strobe assertion length. If IORDY is negated when the initial sample point is reached, additional wait-states are added. Since the rising edge of IORDY must be synchronized, at least two additional PCI clocks are added.

Shutdown latency is incurred after outstanding scheduled IDE data port transactions (either a non-empty write post buffer or an outstanding read prefetch cycles) have completed and before other transactions can proceed. It provides hold time on the DA[2:0] and CSxx# lines with respect to the read and write strobes (DIOR# and DIOW#). Shutdown latency is two PCI clocks in duration.

The IDE timings for various transaction types are shown in [Table 5-53](#). Note that bit 2 (16-bit I/O recovery enable) of the ISA I/O Recovery Timer Register does not add wait-states to IDE data port read accesses when any of the fast timing modes are enabled.

Table 5-53. IDE Transaction Timings (PCI Clocks)

IDE Transaction Type	Startup Latency	IORDY Sample Point (ISP)	Recovery Time (RCT)	Shutdown Latency
Non-Data Port Compatible	4	11	22	2
Data Port Compatible	3	6	14	2
Fast Timing Mode	2	2–5	1–4	2

5.15.1.4 IORDY Masking

The IORDY signal can be ignored and assumed asserted at the first IORDY Sample Point (ISP) on a drive by drive basis via the IDETIM Register.

5.15.1.5 PIO 32-Bit IDE Data Port Accesses

A 32-bit PCI transaction run to the IDE data address (01F0h primary, 0170h secondary) results in two back-to-back 16-bit transactions to the IDE data port. The 32-bit data port feature is enabled for all timings, not just enhanced timing. For compatible timings, a shutdown and startup latency is incurred between the two, 16-bit halves of the IDE transaction. This guarantees that the chip selects will be deasserted for at least two PCI clocks between the two cycles.

5.15.1.6 PIO IDE Data Port Prefetching and Posting

The ICH4 can be programmed via the IDETIM registers to allow data to be posted to and prefetched from the IDE data ports. Data prefetching is initiated when a data port read occurs. The read prefetch eliminates latency to the IDE data ports and allows them to be performed back to back for the highest possible PIO data transfer rates. The first data port read of a sector is called the demand read. Subsequent data port reads from the sector are called prefetch reads. The demand read and all prefetch reads must be the same size (16 or 32 bits).

Data posting is performed for writes to the IDE data ports. The transaction is completed on the PCI bus after the data is received by the ICH4. The ICH4 will then run the IDE cycle to transfer the data to the drive. If the ICH4 write buffer is non-empty and an unrelated (non-data or opposite channel) IDE transaction occurs, that transaction will be stalled until all current data in the write buffer is transferred to the drive.

5.15.2 Bus Master Function

The ICH4 can act as a PCI Bus master on behalf of an IDE slave device. Two PCI Bus master channels are provided, one channel for each IDE connector (primary and secondary). By performing the IDE data transfer as a PCI Bus master, the ICH4 off-loads the processor and improves system performance in multitasking environments. Both devices attached to a connector can be programmed for bus master transfers, but only one device per connector can be active at a time.

5.15.2.1 Physical Region Descriptor Format

The physical memory region to be transferred is described by a Physical Region Descriptor (PRD). The PRDs are stored sequentially in a Descriptor Table in memory. The data transfer proceeds until all regions described by the PRDs in the table have been transferred. Note that the ICH4 bus master IDE function does not support memory regions or Descriptor tables located on ISA.

Descriptor Tables must not cross a 64-KB boundary. Each PRD entry in the table is 8 bytes in length. The first 4 bytes specify the byte address of a physical memory region. This memory region must be DWord aligned and must not cross a 64-KB boundary. The next two bytes specify the size or transfer count of the region in bytes (64-KB limit per region). A value of zero in these two bytes indicates 64 KB (thus, the minimum transfer count is 1). If bit 7 (EOT) of the last byte is a 1, it indicates that this is the final PRD in the Descriptor table. Bus master operation terminates when the last descriptor has been retired.

When the Bus Master IDE controller is reading data from the memory regions, bit 1 of the Base Address is masked and byte enables are asserted for all read transfers. When writing data, bit 1 of the Base Address is not masked and if set, causes the lower Word byte enables to be deasserted for the first DWord transfer. The write to PCI typically consists of a 32-byte cache line. If valid data ends prior to end of the cache line, the byte enables are deasserted for invalid data.

The total sum of the byte counts in every PRD of the descriptor table must be equal to or greater than the size of the disk transfer request. If greater than the disk transfer request, the driver must terminate the bus master transaction (by setting bit 0 in the Bus Master IDE Command Register to 0) when the drive issues an interrupt to signal transfer completion.

Figure 5-14. Physical Region Descriptor Table Entry

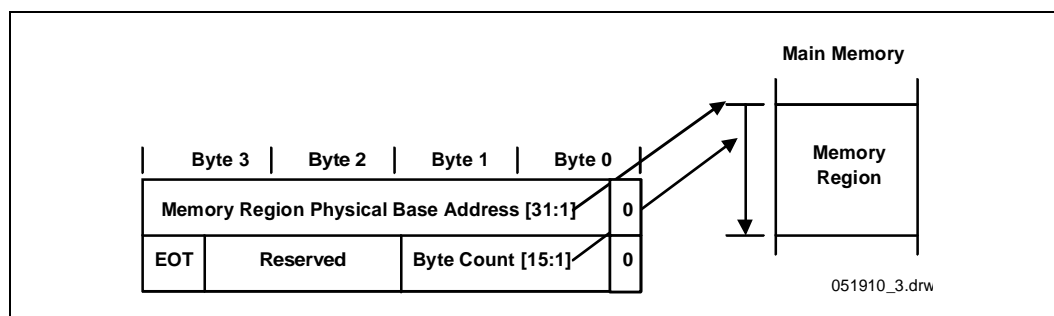

5.15.2.2 Line Buffer

A single line buffer exists for the ICH4 Bus master IDE interface. This buffer is not shared with any other function. The buffer is maintained in either the read state or the write state. Memory writes are typically 4-DWord bursts and invalid DWords have C/BE[3:0]#=0Fh. The line buffer allows burst data transfers to proceed at peak transfer rates.

The Bus Master IDE Active bit in Bus Master IDE Status register is reset automatically when the controller has transferred all data associated with a Descriptor Table (as determined by EOT bit in last PRD). The IDE Interrupt Status bit is set when the IDE device generates an interrupt. These events may occur prior to line buffer emptying for memory writes. If either of these conditions exist, all PCI Master non-memory read accesses to ICH4 are retried until all data in the line buffers has been transferred to memory.

5.15.2.3 Bus Master IDE Timings

The timing modes used for Bus Master IDE transfers are identical to those for PIO transfers. The DMA Timing Enable Only bits in the IDE Timing register can be used to program fast timing mode for DMA transactions only. This is useful for IDE devices whose DMA transfer timings are faster than its PIO transfer timings. The IDE device DMA request signal is sampled on the same PCI clock that DIOR# or DIOW# is deasserted. If inactive, the DMA Acknowledge signal is deasserted on the next PCI clock and no more transfers take place until DMA request is asserted again.

5.15.2.4 Interrupts

Legacy Mode

The ICH4 is connected to IRQ14 for the primary interrupt and IRQ15 for the secondary interrupt. This connection is done from the ISA pin, before any mask registers. This implies the following:

- Bus Master IDE devices are connected directly off of ICH4. IDE interrupts cannot be communicated through PCI devices or the serial stream.

Warning: In this mode, the ICH4 does not drive the PCI Interrupt associated with this function. That is only used in native mode.

Native Mode

In this case both the primary and secondary channels share an interrupt. It will be internally connected to PIRQ[C]# (IRQ18 in APIC mode). The interrupt will be active-low and shared.

Behavioral notes in native mode are:

- The IRQ14 and IRQ15 pins do not affect the internal IRQ14 and IRQ15 inputs to the interrupt controllers. The IDE logic forces these signals inactive in such a way that the Serial IRQ source may be used.
- The IRQ14 and IRQ15 inputs (not external IRQ[14:15] pins) to the interrupt controller can come from other sources (Serial IRQ, PIRQx).
- The IRQ14 and IRQ15 pins are inverted from active-high to the active-low PIRQ.
- When switching the IDE controller to native mode, the IDE Interrupt Pin register (see [Section 10.1.19](#)) will be masked. If an interrupt occurs while the masking is in place and the interrupt is still active when the masking ends, the interrupt will be allowed to be asserted.

5.15.2.5 Bus Master IDE Operation

To initiate a bus master transfer between memory and an IDE device, the following steps are required:

1. Software prepares a PRD Table in system memory. The PRD Table must be DWord-aligned and must not cross a 64-KB boundary.
2. Software provides the starting address of the PRD Table by loading the PRD Table Pointer Register. The direction of the data transfer is specified by setting the Read/Write Control bit. The interrupt bit and Error bit in the Status register are cleared.
3. Software issues the appropriate DMA transfer command to the disk device.
4. The bus master function is engaged by software writing a 1 to the Start bit in the Command Register. The first entry in the PRD table is fetched and loaded into two registers which are not

visible by software, the Current Base and Current Count registers. These registers hold the current value of the address and byte count loaded from the PRD table. The value in these registers is only valid when there is an active command to an IDE device.

5. Once the PRD is loaded internally, the IDE device receives a DMA acknowledge.
6. The controller transfers data to/from memory responding to DMA requests from the IDE device. The IDE device and the host controller may or may not throttle the transfer several times. When the last data transfer for a region has been completed on the IDE interface, the next descriptor is fetched from the table. The descriptor contents are loaded into the Current Base and Current Count registers.
7. At the end of the transfer the IDE device signals an interrupt.
8. In response to the interrupt, software resets the Start/Stop bit in the command register. It then reads the controller status followed by the drive status to determine if the transfer completed successfully.

The last PRD in a table has the End of List (EOL) bit set. The PCI bus master data transfers will terminate when the physical region described by the last PRD in the table has been completely transferred. The active bit in the Status Register will be reset and the DDRQ signal will be masked.

The buffer is flushed (when in the write state) or invalidated (when in the read state) when a terminal count condition exists; that is, the current region descriptor has the EOL bit set and that region has been exhausted. The buffer is also flushed (write state) or invalidated (read state) when the Interrupt bit in the Bus Master IDE Status register is set. Software that reads the status register and finds the Error bit reset, and either the Active bit reset or the Interrupt bit set, can be assured that all data destined for system memory has been transferred and that data is valid in system memory. [Table 5-54](#) describes how to interpret the Interrupt and Active bits in the Status Register after a DMA transfer has started.

During concurrent DMA or Ultra ATA transfers, the ICH4 IDE interface arbitrates between the primary and secondary IDE cables when a PRD expires.

Table 5-54. Interrupt/Active Bit Interaction Definition

Interrupt	Active	Description
0	1	DMA transfer is in progress. No interrupt has been generated by the IDE device.
1	0	The IDE device generated an interrupt. The controller exhausted the Physical Region Descriptors. This is the normal completion case where the size of the physical memory regions was equal to the IDE device transfer size.
1	1	The IDE device generated an interrupt. The controller has not reached the end of the physical memory regions. This is a valid completion case where the size of the physical memory regions was larger than the IDE device transfer size.
0	0	This bit combination signals an error condition. If the Error bit in the status register is set, then the controller has some problem transferring data to/from memory. Specifics of the error have to be determined using bus-specific information. If the Error bit is not set, then the PRD's specified a smaller size than the IDE transfer size.

5.15.2.6 Error Conditions

IDE devices are sector-based mass storage devices. The drivers handle errors on a sector basis; either a sector is transferred successfully or it is not. A sector is 512 bytes.

If the IDE device does not complete the transfer due to a hardware or software error, the command will eventually be stopped by the driver setting Command Start bit to 0 when the driver times out the disk transaction. Information in the IDE device registers help isolate the cause of the problem.

If the controller encounters an error while doing the bus master transfers it will stop the transfer (i.e., reset the Active bit in the Command register) and set the Error bit in the Bus Master IDE Status register. The controller does not generate an interrupt when this happens. The device driver can use device specific information (PCI Configuration Space Status register and IDE Drive Register) to determine what caused the error.

When a requested transfer does not complete properly, information in the IDE device registers (Sector Count) can be used to determine how much of the transfer was completed and to construct a new PRD table to complete the requested operation. In most cases the existing PRD table can be used to complete the operation.

5.15.2.7 8237-Like Protocol

The 8237 mode DMA is similar in form to DMA used on the ISA bus. This mode uses pins familiar to the ISA bus, namely a DMA Request, a DMA Acknowledge, and I/O read/write strobes. These pins have similar characteristics to their ISA counterparts in terms of when data is valid relative to strobe edges, and the polarity of the strobes; however, the ICH4 does not use the 8237 for this mode.

5.15.3 Ultra ATA/33 Protocol

Ultra ATA/33 is enabled through configuration register 48h in Device 31:Function 1 for each IDE device. The IDE signal protocols are significantly different under this mode than for 8237 mode.

Ultra ATA/33 is a physical protocol used to transfer data between a Ultra ATA/33 capable IDE controller (e.g., the ICH4) and one or more Ultra ATA/33 capable IDE devices. It utilizes the standard Bus Master IDE functionality and interface to initiate and control the transfer. Ultra ATA/33 utilizes a “source synchronous” signaling protocol to transfer data at rates up to 33 MB/s. The Ultra ATA/33 definition also incorporates a Cyclic Redundancy Checking (CRC-16) error checking protocol.

5.15.3.1 Signal Descriptions

The Ultra ATA/33 protocol requires no extra signal pins on the IDE connector. It does redefine a number of the standard IDE control signals when in Ultra ATA/33 mode. These redefinitions are shown in Table 5-55. Read cycles are defined as transferring data from the IDE device to the ICH4. Write cycles are defined as transferring data from ICH4 to IDE device.

Table 5-55. UltraATA/33 Control Signal Redefinitions

Standard IDE Signal Definition	Ultra ATA/33 Read Cycle Definition	Ultra ATA/33 Write Cycle Definition	ICH4 Primary Channel Signal	ICH4 Secondary Channel Signal
DLOW#	STOP	STOP	PDIOW#	SDLOW#
DLOW#	DMARDY#	STROBE	PDIOR#	SDIOR#
DIOR#	STROBE	DMARDY#	PIORDY	SIORDY

The DLOW# signal is redefined as STOP for both read and write transfers. This is always driven by the ICH4 and is used to request that a transfer be stopped or as an acknowledgment to stop a request from the IDE device.

The DIOR# signal is redefined as DMARDY# for transferring data from the IDE device to the ICH4 (read). It is used by the ICH4 to signal when it is ready to transfer data and to add wait-states to the current transaction. The DIOR# signal is redefined as STROBE for transferring data from the ICH4 to the IDE device (write). It is the data strobe signal driven by the ICH4 on which data is transferred during each rising and falling edge transition.

The IORDY signal is redefined as STROBE for transferring data from the IDE device to the ICH4 (read). It is the data strobe signal driven by the IDE device on which data is transferred during each rising and falling edge transition. The IORDY signal is redefined as DMARDY# for transferring data from the ICH4 to the IDE device (write). It is used by the IDE device to signal when it is ready to transfer data and to add wait-states to the current transaction.

All other signals on the IDE connector retain their functional definitions during Ultra ATA/33 operation.

5.15.3.2 Operation

Initial setup programming consists of enabling and performing the proper configuration of ICH4 and the IDE device for Ultra ATA/33 operation. For ICH4, this consists of enabling synchronous DMA mode and setting up appropriate Synchronous DMA timings.

When ready to transfer data to or from an IDE device, the Bus Master IDE programming model is followed. Once programmed, the drive and ICH4 control the transfer of data via the Ultra ATA/33 protocol. The actual data transfer consists of three phases, a start-up phase, a data transfer phase, and a burst termination phase.

The IDE device begins the start-up phase by asserting DMARQ signal. When ready to begin the transfer, the ICH4 asserts DMACK# signal. When DMACK# signal is asserted, the host controller drives CS0# and CS1# inactive, DA0–DA2 low. For write cycles, the ICH4 deasserts STOP, waits for the IDE device to assert DMARDY#, and then drives the first data word and STROBE signal. For read cycles, the ICH4 tri-states the DD lines, deasserts STOP, and asserts DMARDY#. The IDE device then sends the first data word and STROBE.

The data transfer phase continues the burst transfers with the data transmitter (ICH4 - writes, IDE device - reads) providing data and toggling STROBE. Data is transferred (latched by receiver) on each rising and falling edge of STROBE. The transmitter can pause the burst by holding STROBE high or low, resuming the burst by again toggling STROBE. The receiver can pause the burst by deasserting DMARDY# and resumes the transfers by asserting DMARDY#. The ICH4 pauses a burst transaction to prevent an internal line buffer over or under flow condition, resuming once the condition has cleared. It may also pause a transaction if the current PRD byte count has expired, resuming once it has fetched the next PRD.

The current burst can be terminated by either the transmitter or receiver. A burst termination consists of a Stop Request, Stop Acknowledge and transfer of CRC data. The ICH4 can stop a burst by asserting STOP, with the IDE device acknowledging by deasserting DMARQ. The IDE device stops a burst by deasserting DMARQ and the ICH4 acknowledges by asserting STOP. The transmitter then drives the STROBE signal to a high level. The ICH4 then drives the CRC value onto the DD lines and deasserts DMACK#. The IDE device latches the CRC value on the rising edge of DMACK#. The ICH4 terminates a burst transfer if it needs to service the opposite IDE channel, if a Programmed I/O (PIO) cycle is executed to the IDE channel currently running the burst, or upon transferring the last data from the final PRD.

5.15.3.3 CRC Calculation

Cyclic Redundancy Checking (CRC-16) is used for error checking on Ultra ATA/33 transfers. The CRC value is calculated for all data by both the ICH4 and the IDE device over the duration of the Ultra ATA/33 burst transfer segment. This segment is defined as all data transferred with a valid STROBE edge from DDACK# assertion to DDACK# deassertion. At the end of the transfer burst segment, the ICH4 drives the CRC value onto the DD[15:0] signals. It is then latched by the IDE device on deassertion of DDACK#. The IDE device compares the ICH4 CRC value to its own and reports an error if there is a mismatch.

5.15.4 Ultra ATA/66 Protocol

In addition to Ultra ATA/33, the ICH4 supports the Ultra ATA/66 protocol. The Ultra ATA/66 protocol is enabled via configuration bits 3:0 at offset 54h. The two protocols are similar, and are intended to be device driver compatible. The Ultra ATA/66 logic can achieve transfer rates of up to 66 MB/s.

To achieve the higher data rate, the timings are shortened and the quality of the cable is improved to reduce reflections, noise, and inductive coupling. Note that the improved cable is required and will still plug into the standard IDE connector. The Ultra ATA/66 protocol also supports a 44 MB/s mode.

5.15.5 Ultra ATA/100 Protocol

When the ATA_FAST bit is set for any of the four IDE devices, then the timings for the transfers to and from the corresponding device run at a higher rate. The ICH4 Ultra ATA/100 logic can achieve read transfer rates up to 100MB/s, and write transfer rates up to 88.9MB/s.

The cable improvements required for Ultra ATA/66 are sufficient for Ultra ATA/100, so no further cable improvements are required when implementing Ultra ATA/100.

5.15.6 Ultra ATA/33/66/100 Timing

The timings for Ultra ATA/33/66/100 modes are programmed via the Synchronous DMA Timing Register and the IDE Configuration Register. Different timings can be programmed for each drive in the system. The Base Clock frequency for each drive is selected in the IDE Configuration Register. The Cycle Time (CT) and Ready to Pause (RP) time (defined as multiples of the Base Clock) are programmed in the Synchronous DMA Timing Register. The Cycle Time represents the minimum pulse width of the data strobe (STROBE) signal. The Ready to Pause time represents the number of Base Clock periods that the ICH4 will wait from deassertion of DMARDY# to the assertion of STOP when it desires to stop a burst read transaction.

Note: The internal Base Clock for Ultra ATA/100 (Mode 5) runs at 133 MHz, and the Cycle Time (CT) must be set for three Base Clocks. The ICH4 will thus toggle the write strobe signal every 22.5 ns, transferring two bytes of data on each strobe edge. This means that the ICH4 will perform Mode 5 write transfers at a maximum rate of 88.9 MB/s. For read transfers, the read strobe will be driven by the ATA/100 device, and the ICH4 supports reads at the maximum rate of 100 MB/s.

5.15.7 IDE Swap Bay

To support a swap bay, the ICH4 allows the IDE output signals to be tri-stated and input buffers to be turned off. This should be done prior to the removal of the drive. The output signals can also be driven low. This can be used to remove charge built up on the signals. Configuration bits are included in the IDE I/O Configuration Register, offset 54h in the IDE PCI configuration space.

In an IDE Hot Swap Operation, an IDE device is removed and a new one inserted while the IDE interface is powered down and the rest of the system is in a fully powered-on state (SO). During an IDE Hot Swap, if the operating system executes cycles to the IDE interface after it has been powered down, it will cause the ICH4 to hang the system that is waiting for IORDY to be asserted from the drive. To correct this issue, the following BIOS procedures are required for performing an IDE hot swap.

1. Program IDE SIG_MODE (offset 54h) to 10b (drive low mode).
2. Clear IORDY Sample Point Enable (bits 1 or 5 of IDE Timing register). This prevents ICH4 from waiting for IORDY assertion when the operating system accesses the IDE device after the IDE drive powers down, and ensures that zeros will always be returned for read cycles that occur during hot swap operation.

Warning: The software should **not** attempt to control the outputs (either tri-state or driving low), while an IDE transfer is in progress. Unpredictable results could occur, including a system lockup.

5.16 USB UHCI Controllers (D29:F0, F1 and F2)

The ICH4 contains three USB UHCI Host controllers. Each Host controller includes a root hub with two separate USB ports each, for a total of 6 USB ports. The ICH4 Host controllers support the standard *Universal Host Controller Interface (UHCI) Specification, Revision 1.1*.

- Overcurrent detection on all six USB ports is supported. The overcurrent inputs are 5 V-tolerant, and can be used as GPIs if not needed.
- The ICH4's USB UHCI controllers are arbitrated differently than standard PCI devices to improve arbitration latency.
- The USB UHCI controllers use the Analog Front End (AFE) embedded cell that allows support for USB High-speed signaling rates, instead of USB I/O buffers.

5.16.1 Data Structures in Main Memory

This section describes the details of the data structures used to communicate control, status, and data between software and the ICH4: Frame Lists, Transfer Descriptors, and Queue Heads. Frame Lists are aligned on 4-KB boundaries. Transfer Descriptors and Queue Heads are aligned on 16-byte boundaries.

5.16.1.1 Frame List Pointer

The frame list pointer contains a link pointer to the first data object to be processed in the frame, as well as the control bits defined in [Table 5-56](#).

Table 5-56. Frame List Pointer Bit Description

Bit	Description
31:4	Frame List Pointer (FLP) . This field contains the address of the first data object to be processed in the frame and corresponds to memory address signals [31:4], respectively.
3:2	Reserved. These bits must be written as 0.
1	QH/TD Select (Q) . This bit indicates to the hardware whether the item referenced by the link pointer is a TD (Transfer Descriptor) or a QH (Queue Head). This allows the Intel® ICH4 to perform the proper type of processing on the item after it is fetched. 0 = TD 1 = QH
0	Terminate (T) . This bit indicates to the ICH4 whether the schedule for this frame has valid entries in it. 0 = Pointer is valid (points to a QH or TD). 1 = Empty Frame (pointer is invalid).

5.16.1.2 Transfer Descriptor (TD)

Transfer Descriptors (TDs) express the characteristics of the transaction requested on USB by a client. TDs are always aligned on 16-byte boundaries, and the elements of the TD are shown in Figure 5-15. The 4 different USB transfer types are supported by a small number of control bits in the descriptor that the ICH4 interprets during operation. All Transfer Descriptors have the same basic, 32-byte structure. During operation, the ICH4 hardware performs consistency checks on some fields of the TD. If a consistency check fails, the ICH4 halts immediately and issues an interrupt to the system. This interrupt cannot be masked within the ICH4.

Figure 5-15. Transfer Descriptor

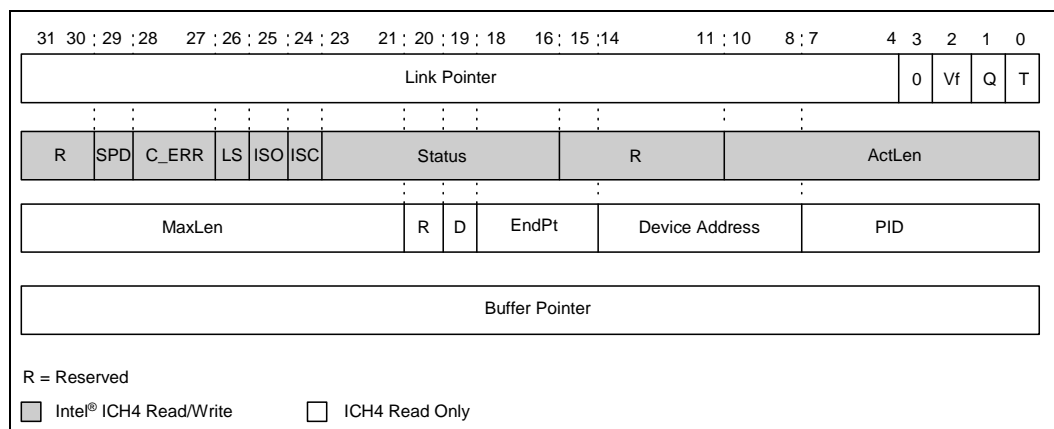

Table 5-57. TD Link Pointer

Bit	Description
31:4	Link Pointer (LP). Bits [31:4] Correspond to memory address signals [31:4], respectively. This field points to another TD or QH.
3	Reserved. Must be 0 when writing this field.
2	Depth/Breadth Select (VF). This bit is only valid for queued TDs and indicates to the hardware whether it should process in a depth first or breadth first fashion. When set to depth first, it informs the Intel® ICH4 to process the next transaction in the queue rather than starting a new queue. 0 = Breadth first 1 = Depth first
1	QH/TD Select (Q). This bit informs the ICH4 whether the item referenced by the link pointer is another TD or a QH. This allows the ICH4 to perform the proper type of processing on the item after it is fetched. 0 = TD 1 = QH
0	Terminate (T). This bit informs the ICH4 that the link pointer in this TD does not point to another valid entry. When encountered in a queue context, this bit indicates to the ICH4 that there are no more valid entries in the queue. A TD encountered outside of a queue context with the T bit set informs the ICH4 that this is the last TD in the frame. 0 = Link Pointer field is valid. 1 = Link Pointer field not valid.

Table 5-58. TD Control and Status (Sheet 1 of 2)

Bit	Description																																								
31:30	Reserved.																																								
29	<p>Short Packet Detect (SPD). When a packet has this bit set to 1 and the packet is an input packet, is in a queue; and successfully completes with an actual length less than the maximum length, then the TD is marked inactive, the Queue Header is not updated, and the USBINT status bit (Status Register) is set at the end of the frame. In addition, if the interrupt is enabled, the interrupt will be sent at the end of the frame.</p> <p>Note that any error (e.g., babble or FIFO error) prevents the short packet from being reported. The behavior is undefined when this bit is set with output packets or packets outside of queues.</p> <p>0 = Disable 1 = Enable</p>																																								
28:27	<p>Error Counter (C_ERR). This field is a 2-bit down counter that keeps track of the number of Errors detected while executing this TD. If this field is programmed with a non zero value during setup, the ICH4 decrements the count and writes it back to the TD if the transaction fails. If the counter counts from one to zero, the Intel[®] ICH4 marks the TD inactive, sets the “STALLED” and error status bit for the error that caused the transition to zero in the TD. An interrupt will be generated to Host controller Driver (HCD) if the decrement to zero was caused by Data Buffer error, Bit stuff error, or if enabled, a CRC or Timeout error. If HCD programs this field to zero during setup, the ICH4 will not count errors for this TD and there will be no limit on the retries of this TD.</p> <table border="0"> <tr> <td>Bits[28:27]</td> <td>Interrupt After</td> <td></td> <td></td> </tr> <tr> <td>00</td> <td>No Error Limit</td> <td></td> <td></td> </tr> <tr> <td>01</td> <td>1 Error</td> <td></td> <td></td> </tr> <tr> <td>10</td> <td>2 Errors</td> <td></td> <td></td> </tr> <tr> <td>11</td> <td>3 Errors</td> <td></td> <td></td> </tr> </table> <table border="0"> <tr> <td>Error</td> <td>Decrement Counter</td> <td>Error</td> <td>Decrement Counter</td> </tr> <tr> <td>CRC Error</td> <td>Yes</td> <td>Data Buffer Error</td> <td>Yes</td> </tr> <tr> <td>Timeout Error</td> <td>Yes</td> <td>Stalled</td> <td>No¹</td> </tr> <tr> <td>NAK Received</td> <td>No</td> <td>Bit stuff Error</td> <td>Yes</td> </tr> <tr> <td>Babble Detected</td> <td>No¹</td> <td></td> <td></td> </tr> </table> <p>NOTE 1. Detection of Babble or Stall automatically deactivates the TD. Thus, count is not decremented.</p>	Bits[28:27]	Interrupt After			00	No Error Limit			01	1 Error			10	2 Errors			11	3 Errors			Error	Decrement Counter	Error	Decrement Counter	CRC Error	Yes	Data Buffer Error	Yes	Timeout Error	Yes	Stalled	No ¹	NAK Received	No	Bit stuff Error	Yes	Babble Detected	No ¹		
Bits[28:27]	Interrupt After																																								
00	No Error Limit																																								
01	1 Error																																								
10	2 Errors																																								
11	3 Errors																																								
Error	Decrement Counter	Error	Decrement Counter																																						
CRC Error	Yes	Data Buffer Error	Yes																																						
Timeout Error	Yes	Stalled	No ¹																																						
NAK Received	No	Bit stuff Error	Yes																																						
Babble Detected	No ¹																																								
26	<p>Low Speed Device (LS). This bit indicates that the target device (USB data source or sink) is a low speed device, running at 1.5 Mb/s, instead of at full speed (12 Mb/sec). There are special restrictions on schedule placement for low speed TDs. If an ICH4 root hub port is connected to a full speed device and this bit is set to a 1 for a low speed transaction, the ICH4 sends out a low speed preamble on that port before sending the PID. No preamble is sent if an ICH4 root hub port is connected to a low speed device.</p> <p>0 = Full-Speed Device 1 = Low-Speed Device</p>																																								
25	<p>Isochronous Select (IOS). The field specifies the type of the data structure. If this bit is set to a 1, the TD is an isochronous transfer. Isochronous TDs are always marked inactive by the hardware after execution, regardless of the results of the transaction.</p> <p>0 = Non-isochronous Transfer Descriptor 1 = Isochronous Transfer Descriptor</p>																																								
24	<p>Interrupt on Complete (IOC). This specifies that the ICH4 should issue an interrupt on completion of the frame in which this Transfer Descriptor is executed. Even if the Active bit in the TD is already cleared when the TD is fetched (no transaction will occur on USB), an IOC interrupt is generated at the end of the frame.</p> <p>1 = Issue IOC</p>																																								
23	<p>Active. For ICH4 schedule execution operations, see Section 5.16.2, Data Transfers to/from Main Memory.</p> <p>0 = When the transaction associated with this descriptor is completed, the ICH4 sets this bit to 0 indicating that the descriptor should not be executed when it is next encountered in the schedule. The Active bit is also set to 0 if a stall handshake is received from the endpoint.</p> <p>1 = Set to 1 by software to enable the execution of a message transaction by the ICH4.</p>																																								

Table 5-58. TD Control and Status (Sheet 2 of 2)

Bit	Description
22	Stalled. 1 = Set to a 1 by the ICH4 during status updates to indicate that a serious error has occurred at the device/endpoint addressed by this TD. This can be caused by babble, the error counter counting down to zero, or reception of the STALL handshake from the device during the transaction. Any time that a transaction results in the Stalled bit being set, the Active bit is also cleared (set to 0). If a STALL handshake is received from a SETUP transaction, a Time Out Error will also be reported.
21	Data Buffer Error (DBE). 1 = Set to a 1 by the ICH4 during status update to indicate that the ICH4 is unable to keep up with the reception of incoming data (overrun) or is unable to supply data fast enough during transmission (underrun). When this occurs, the actual length and Max Length field of the TD will not match. In the case of an underrun, the ICH4 will transmit an incorrect CRC (thus invalidating the data at the endpoint) and leave the TD active (unless error count reached zero). If a overrun condition occurs, the ICH4 will force a timeout condition on the USB, invalidating the transaction at the source.
20	Babble Detected (BABD). 1 = Set to a 1 by the ICH4 during status update when "babble" is detected during the transaction generated by this descriptor. Babble is unexpected bus activity for more than a preset amount of time. In addition to setting this bit, the ICH4 also sets the "STALLED" bit (bit 22) to a 1. Since "babble" is considered a fatal error for that transfer, setting the "STALLED" bit to a 1 insures that no more transactions occur as a result of this descriptor. Detection of babble causes immediate termination of the current frame. No further TDs in the frame are executed. Execution resumes with the next frame list index.
19	Negative Acknowledgment (NAK) Received (NAKR). 1 = Set to a 1 by the ICH4 during status update when the ICH4 receives a "NAK" packet during the transaction generated by this descriptor. If a NAK handshake is received from a SETUP transaction, a Time Out Error will also be reported.
18	CRC/Time Out Error (CRC_TOUT). 1 = Set to a 1 by the ICH4 as follows: <ul style="list-style-type: none"> During a status update in the case that no response is received from the target device/endpoint within the time specified by the protocol chapter of the USB specification. During a status update when a Cyclical Redundancy Check (CRC) error is detected during the transaction associated with this transfer descriptor. In the transmit case (OUT or SETUP Command), this is in response to the ICH4 detecting a timeout from the target device/endpoint. In the receive case (IN Command), this is in response to the ICH4's CRC checker circuitry detecting an error on the data received from the device/endpoint or a NAK or STALL handshake being received in response to a SETUP transaction.
17	Bit stuff Error (BSE). 1 = This bit is set to a 1 by the ICH4 during status update to indicate that the receive data stream contained a sequence of more than 6 ones in a row.
16	Bus Turn Around Time-out (BTTO). 1 = This bit is set to a 1 by the ICH4 during status updates to indicate that a bus time-out condition was detected for this USB transaction. This time-out is specially defined as not detecting an IDLE-to 'K' state Start of Packet (SOP) transition from 16 to 18-bit times after the SE0-to-IDLE transition of previous End of Packet (EOP).
15:11	Reserved
10:0	Actual Length (ACTLEN). The Actual Length field is written by the ICH4 at the conclusion of a USB transaction to indicate the actual number of bytes that were transferred. It can be used by the software to maintain data integrity. The value programmed in this register is encoded as n-1 (see Maximum Length field description in the TD Token).

Table 5-59. TD Token

Bit	Description
31:21	<p>Maximum Length (MAXLEN). The Maximum Length field specifies the maximum number of data bytes allowed for the transfer. The Maximum Length value does not include protocol bytes, such as Packet ID (PID) and CRC. The maximum data packet is 1280 bytes. The 1280 packet length is the longest packet theoretically guaranteed to fit into a frame. Actual packet maximum lengths are set by HCD according to the type and speed of the transfer. Note that the maximum length allowed by the USB specification is 1023 bytes. The valid encodings for this field are:</p> <p>0x000 = 1 byte 0x001 = 2 bytes 0x3FE = 1023 bytes 0x3FF = 1024 bytes 0x4FF = 1280 bytes 0x7FF = 0 bytes (null data packet)</p> <p>Note that values from 500h to 7FEh are illegal and cause a consistency check failure.</p> <p>In the transmit case, the Intel[®] ICH4 uses this value as a terminal count for the number of bytes it fetches from host memory. In most cases, this is the number of bytes it will actually transmit. In rare cases, the ICH4 may be unable to access memory (e.g., due to excessive latency) in time to avoid underrunning the transmitter. In this instance the ICH4 would transmit fewer bytes than specified in the Maximum Length field.</p>
20	Reserved.
19	<p>Data Toggle (D). This bit is used to synchronize data transfers between a USB endpoint and the host. This bit determines which data PID is sent or expected (0=DATA0 and 1=DATA1). The Data Toggle bit provides a 1-bit sequence number to check whether the previous packet completed. This bit must always be 0 for Isochronous TDs.</p>
18:15	<p>Endpoint (ENDPT). This 4-bit field extends the addressing internal to a particular device by providing 16 endpoints. This permits more flexible addressing of devices in which more than one sub-channel is required.</p>
14:8	<p>Device Address. This field identifies the specific device serving as the data source or sink.</p>
7:0	<p>Packet Identification (PID). This field contains the Packet ID to be used for this transaction. Only the IN (69h), OUT (E1h), and SETUP (2Dh) tokens are allowed. Any other value in this field causes a consistency check failure resulting in an immediate halt of the ICH4. Bits [3:0] are complements of bits [7:4].</p>

Table 5-60. TD Buffer Pointer

Bit	Description
31:0	<p>Buffer Pointer (BUFF_PNT). Bits [31:0] corresponds to memory address [31:0], respectively. It points to the beginning of the buffer that will be used during this transaction. This buffer must be at least as long as the value in the Maximum Length field described in the TD token. The data buffer may be byte-aligned.</p>

5.16.1.3 Queue Head (QH)

Queue heads are special structures used to support the requirements of Control, Bulk, and Interrupt transfers. Since these TDs are not automatically retired after each use, their maintenance requirements can be reduced by putting them into a queue. Queue Heads must be aligned on a 16-byte boundary, and the elements are shown in [Table 5-61](#).

Table 5-61. Queue Head Block

Bytes	Description	Attributes
00–03	Queue Head Link Pointer	RO
04–07	Queue Element Link Pointer	R/W

Table 5-62. Queue Head Link Pointer

Bit	Description
31:4	Queue Head Link Pointer (QHLP) . This field contains the address of the next data object to be processed in the horizontal list and corresponds to memory address signals [31:4], respectively.
3:2	Reserved. These bits must be written as zeros.
1	QH/TD Select (Q) . This bit indicates to the hardware whether the item referenced by the link pointer is another TD or a QH. 0 = TD 1 = QH
0	Terminate (T) . This bit indicates to the Intel® ICH4 that this is the last QH in the schedule. If there are active TDs in this queue, they are the last to be executed in this frame. 0 = Pointer is valid (points to a QH or TD). 1 = Last QH (pointer is invalid).

Table 5-63. Queue Element Link Pointer

Bit	Description
31:4	Queue Element Link Pointer (QELP) . This field contains the address of the next TD or QH to be processed in this queue and corresponds to memory address signals [31:4], respectively.
3:2	Reserved.
1	QH/TD Select (Q) . This bit indicates to the hardware whether the item referenced by the link pointer is another TD or a QH. For entries in a queue, this bit is typically set to 0. 0 = TD 1 = QH
0	Terminate (T) . This bit indicates to the Intel® ICH4 that there are no valid TDs in this queue. When HCD has new queue entries it overwrites this value with a new TD pointer to the queue entry. 0 = Pointer is valid. 1 = Terminate (No valid queue entries).

5.16.2 Data Transfers to/from Main Memory

The following sections describe the details on how HCD and the ICH4 communicate via the Schedule data structures. The discussion is organized in a top-down manner, beginning with the basics of walking the Frame List, followed by a description of generic processing steps common to all transfer descriptors, and finally a discussion on Transfer Queuing.

5.16.2.1 Executing the Schedule

Software programs the ICH4 with the starting address of the Frame List and the Frame List index, then causes the ICH4 to execute the schedule by setting the Run/Stop bit in the Control register to Run. The ICH4 processes the schedule one entry at a time: the next element in the frame list is not fetched until the current element in the frame list is retired.

Schedule execution proceeds in the following fashion:

- The ICH4 first fetches an entry from the Frame List. This entry has three fields. Bit 0 indicates whether the address pointer field is valid. Bit 1 indicates whether the address points to a Transfer Descriptor or to a queue head. The third field is the pointer itself.
- If isochronous traffic is to be moved in a given frame, the Frame List entry points to a Transfer Descriptor. If no isochronous data is to be moved in that frame, the entry points to a queue head or the entry is marked invalid and no transfers are initiated in that frame.
- If the Frame List entry indicates that it points to a Transfer Descriptor, the ICH4 fetches the entry and begins the operations necessary to initiate a transaction on USB. Each TD contains a link field that points to the next entry, as well as indicating whether it is a TD or a QH.
- If the Frame List entry contains a pointer to a QH, the ICH4 processes the information from the QH to determine the address of the next data object that it should process.
- The TD/QH process continues until the millisecond allotted to the current frame expires. At this point, the ICH4 fetches the next entry from the Frame List. If the ICH4 is not able to process all of the transfer descriptors during a given frame, those descriptors are retired by software without having been executed.

5.16.2.2 Processing Transfer Descriptors

The ICH4 executes a TD using the following generalized algorithm. These basic steps are common across all modes of TDs. Subsequent sections present processing steps unique to each TD mode.

1. ICH4 fetches TD or QH from the current Link Pointer.
2. If a QH, go to 1 to fetch from the Queue Element Link Pointer. If inactive, go to 12
3. Build token, actual bits are in TD token.
4. If (Host-to-Function) then
 - [*PCI Access*] issue request for data, (referenced through TD.BufferPointer)
 - wait for first chunk data arrival
 - end if
5. [*Begin USB Transaction*] Issue token (from token built in 2, above) and begin data transfer.
 - if (Host-to-Function) then Go to 6
 - else Go to 7
 - end if
6. Fetch data from memory (via TD BufferPointer) and transfer over USB until TD Max-Length bytes have been read and transferred. [*Concurrent system memory and USB Accesses*]. Go to 8.
7. Wait for data to arrive (from USB). Write incoming bytes into memory beginning at TD BufferPointer. Internal HC buffer should signal end of data packet. Number of bytes received must be (TD Max-Length; The length of the memory area referenced by TD BufferPointer must be (TD Max-Length. [*Concurrent system memory and USB Accesses*].
8. Issue handshake based on status of data received (Ack or Time-out). Go to 10.
9. Wait for handshake, if required [*End of USB Transaction*].
10. Update Status [*PCI Access*] (TD.Status and TD.ActualLength).
 - If the TD was an isochronous TD, mark the TD inactive. Go to 12.
 - If not an isochronous TD, and the TD completed successfully, mark the TD inactive. Go to 11.
 - If not successful, and the error count has not been reached, leave the TD active. If the error count has been reached, mark the TD inactive. Go to 12.
11. Write the link pointer from the current TD into the element pointer field of the QH structure. If the Vf bit is set in the TD link pointer, go to 2.
12. Proceed to next entry.

5.16.2.3 Command Register, Status Register, and TD Status Bit Interaction

Table 5-64. Command Register, Status Register, and TD Status Bit Interaction

Condition	Intel® ICH4 USB Status Register Actions	TD Status Register Actions
CRC/Time Out Error	Set USB Error Int bit ¹ , Clear HC Halted bit	Clear Active bit ¹ and set Stall bit ¹
Illegal PID, PID Error, Max Length (illegal)	Clear Run/Stop bit in Command register Set HC Process Error and HC Halted bits	
PCI Master/Target Abort	Clear Run/Stop bit in Command register Set Host System Error and HC Halted bits	
Suspend Mode	Clear Run/Stop bit in Command register ² Set HC Halted bit	
Resume Received and Suspend Mode = 1	Set Resume received bit	
Run/Stop = 0	Clear Run/Stop bit in command register Set HC Halted bit	
Configuration Flag Set	Set Configuration Flag in Command register	
HC Reset/Global Reset	Clear Run/Stop and Configuration Flag in Command register Clear USB Int, USB Error Int, Resume received, Host System Error, HC Process Error, and HC Halted bits	
IOC = 1 in TD Status	Set USB Int bit	
Stall	Set USB Error Int bit	Clear Active bit ¹ and set Stall bit
Bit Stuff/Data Buffer Error	Set USB Error Int bit ¹	Clear Active bit ¹ and set Stall bit ¹
Short Packet Detect	Set USB Int bit	Clear Active bit

NOTES:

1. Only If error counter counted down from 1 to 0
2. Suspend mode can be entered only when Run/Stop bit is 0

Note that if a NAK or STALL response is received from a SETUP transaction, a Time Out Error will be reported. This causes the Error counter to decrement and the CRC/Time-out Error status bit to be set within the TD Control and Status DWord during write back. If the Error counter changes from 1 to 0, the Active bit is reset to 0 and Stalled bit to 1 as normal.

5.16.2.4 Transfer Queuing

Transfer Queues are used to implement a guaranteed data delivery stream to a USB Endpoint. Transfer Queues are composed of two parts: a Queue Header (QH) and a linked list. The linked list of TDs and QHs has an indeterminate length (0 to n).

The QH contains two link pointers and is organized as two contiguous DWords. The first DWord is a horizontal pointer (Queue Head Link Pointer), used to link a single transfer queue with either another transfer queue, or a TD (target data structure depends on Q bit). If the T bit is set, this QH represents the last data structure in the current Frame. The T bit informs the ICH4 that no further processing is required until the beginning of the next frame. The second DWord is a vertical pointer (Queue Element Link Pointer) to the first data structure (TD or QH) being managed by this QH. If the T bit is set, the queue is empty. This pointer may reference a TD or another QH.

Figure 5-16 illustrates four example queue conditions. The first QH (on far left) is an example of an “empty” queue; the termination bit (T Bit) in the vertical link pointer field is set to 1. The horizontal link pointer references another QH. The next queue is the expected typical configuration. The horizontal link pointer references another QH, and the vertical link pointer references a valid TD. The third queue is an example of a queue where the vertical pointer points to another QH. The far right QH is an example of a frame “termination” node. Since its horizontal link pointer has its termination bit set, the ICH4 assumes there is no more work to complete for the current Frame.

Typically, the vertical pointer in a QH points to a TD. However, as shown in Figure 5-16 (third example from left side of figure) the vertical pointer could point to another QH. When this occurs, a new Q Context is entered and the Q Context just exited is NULL (ICH4 will not update the vertical pointer field).

The far right QH is an example of a frame “termination” node. Since its horizontal link pointer has its termination bit set, the ICH4 assumes there is no more work to complete for the current Frame.

Figure 5-16. Example Queue Conditions

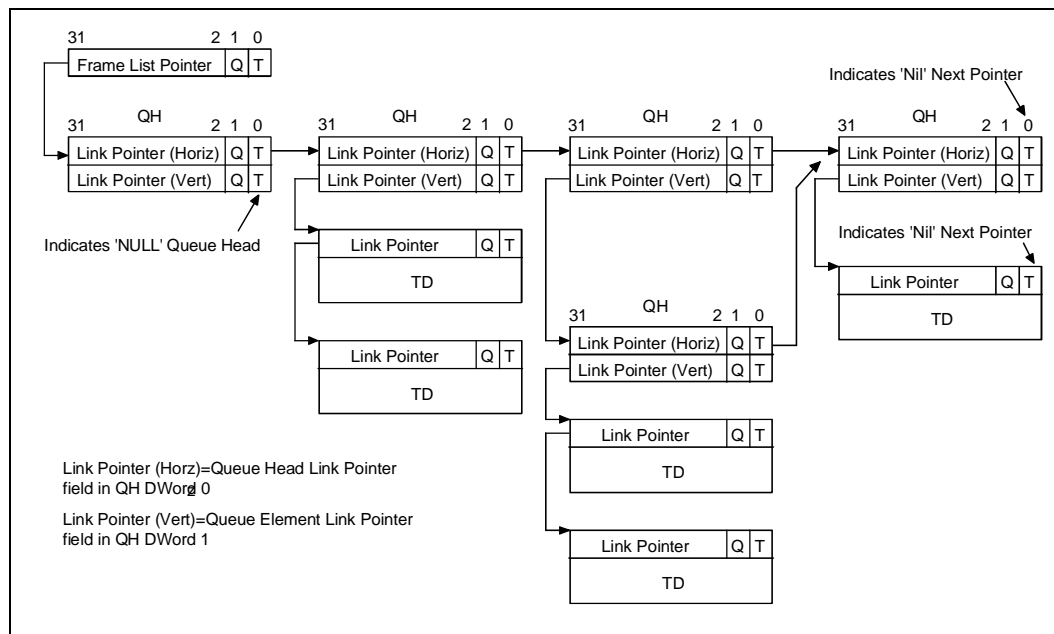

Transfer Queues are based on the following characteristics:

- A QH’s vertical link pointer (Queue Element Link Pointer) references the “Top” queue member. A QH’s horizontal link pointer (Queue Head Link Pointer) references the “next” work element in the Frame.
- Each queue member’s link pointer references the next element within the queue.

In the simplest model, the ICH4 follows vertical link point to a queue element, then executes the element. If the completion status of the TD satisfies the advance criteria as shown in [Table 5-65](#), the ICH4 advances the queue by writing the just-executed TD’s link pointer back into the QH’s Queue Element link pointer. The next time the queue head is traversed, the next queue element will be the Top element.

The traversal has two options: Breadth first, or Depth first. A flag bit in each TD (Vf - Vertical Traversal Flag) controls whether traversal is Breadth or Depth first. The default mode of traversal is Breadth-First. For Breadth-First, the ICH4 only executes the top element from each queue. The execution path is shown below:

1. QH (Queue Element Link Pointer)
2. TD
3. Write-Back to QH (Queue Element Link Pointer)
4. QH (Queue Head Link pointer).

Breadth-First is also performed for every transaction execution that fails the advance criteria. This means that if a queued TD fails, the queue does not advance, and the ICH4 traverses the QH’s Queue Head Link Pointer.

In a Depth-first traversal, the top queue element must complete successfully to satisfy the *advance criteria* for the queue. If the ICH4 is currently processing a queue, and the advance criteria are met, and the Vf bit is set, the ICH4 follows the TD’s link pointer to the next schedule work item.

Note that regardless of traversal model, when the advance criteria are met, the successful TD’s link pointer is written back to the QH’s Queue Element link pointer. When the ICH4 encounters a QH, it caches the QH internally, and sets internal state to indicate it is in a Q-context. It needs this state to update the correct QH (for auto advancement) and also to make the correct decisions on how to traverse the Frame List.

Restricting the advancement of queues to advancement criteria implements a guaranteed data delivery stream. A queue is **never** advanced on an error completion status (even in the event the error count was exhausted). [Table 5-65](#) lists the general queue advance criteria, which are based on the execution status of the TD at the “Top” of a currently “active” queue.

Table 5-65. Queue Advance Criteria

Function-to-Host (IN)			Host-to-Function (OUT)		
Non-NULL	NULL	Error/NAK	Non-NULL	NULL	Error/NAK
Advance Q	Advance Q	Retry Q Element	Advance Q	Advance Q	Retry Q Element

[Table 5-66](#) is a decision table illustrating the valid combinations of link pointer bits and the valid actions taken when advancement criteria for a queued transfer descriptor are met. The column headings for the link pointer fields are encoded, based on the following list:

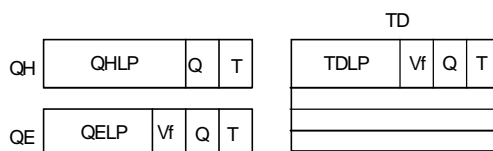

Legends:

QH.LP = Queue Head Link Pointer (or Horizontal Link Pointer)
 QE.LP = Queue Element Link Pointer (or Vertical Link Pointer)
 TD.LP = TD Link Pointer
 QH.Q = Q bit in QH
 QH.T = T bit in QH

QE.Q = Q bit in QE
 QE.T = T bit in QE
 TD.Vf = Vf bit in TD
 TD.Q = Q bit in TD
 TD.T = T bit in TD

Table 5-66. USB Schedule List Traversal Decision Table

Q Context	QH.Q	QH.T	QE.Q	QE.T	TD.Vf	TD.Q	TD.T	Description
0	—	—	—	—	x	0	0	<ul style="list-style-type: none"> Not in Queue - execute TD. Use TD.LP to get next TD
0	—	—	—	—	x	x	1	<ul style="list-style-type: none"> Not in Queue - execute TD. End of Frame
0	—	—	—	—	x	1	0	<ul style="list-style-type: none"> Not in Queue - execute TD. Use TD.LP to get next (QH+QE). Set Q Context to 1.
1	0	0	0	0	0	x	x	<ul style="list-style-type: none"> In Queue. Use QE.LP to get TD. Execute TD. Update QE.LP with TD.LP. Use QH.LP to get next TD.
1	x	x	0	0	1	0	0	<ul style="list-style-type: none"> In Queue. Use QE.LP to get TD. Execute TD. Update QE.LP with TD.LP. Use TD.LP to get next TD.
1	x	x	0	0	1	1	0	<ul style="list-style-type: none"> In Queue. Use QE.LP to get TD. Execute TD. Update QE.LP with TD.LP. Use TD.LP to get next (QH+QE).
1	0	0	x	1	x	x	x	<ul style="list-style-type: none"> In Queue. Empty queue. Use QH.LP to get next TD
1	x	x	1	0	—	—	—	<ul style="list-style-type: none"> In Queue. Use QE.LP to get (QH+QE)
1	x	1	0	0	0	x	x	<ul style="list-style-type: none"> In Queue. Use QE.LP to get TD. Execute TD. Update QE.LP with TD.LP. End of Frame
1	x	1	x	1	x	x	x	<ul style="list-style-type: none"> In Queue. Empty queue. End of Frame
1	1	0	0	0	0	x	x	<ul style="list-style-type: none"> In Queue. Use QE.LP to get TD. Execute TD. Update QE.LP with TD.LP. Use QH.LP to get next (QH+QE).
1	1	0	x	1	x	x	x	<ul style="list-style-type: none"> In Queue. Empty queue. Use QH.LP to get next (QH+QE)

5.16.3 Data Encoding and Bit Stuffing

The USB employs NRZI data encoding (Non-Return to Zero Inverted) when transmitting packets. In NRZI encoding; a one is represented by no change in level, and a zero is represented by a change in level. A string of zeros causes the NRZI data to toggle each bit time. A string of ones causes long periods with no transitions in the data. To ensure adequate signal transitions, bit stuffing is employed by the transmitting device when sending a packet on the USB. A zero is inserted after every six, consecutive ones in the data stream before the data is NRZI encoded to force a transition in the NRZI data stream. This gives the receiver logic a data transition at least once every seven bit times to guarantee the data and clock lock. A waveform of the data encoding is shown in Figure 5-17.

Figure 5-17. USB Data Encoding

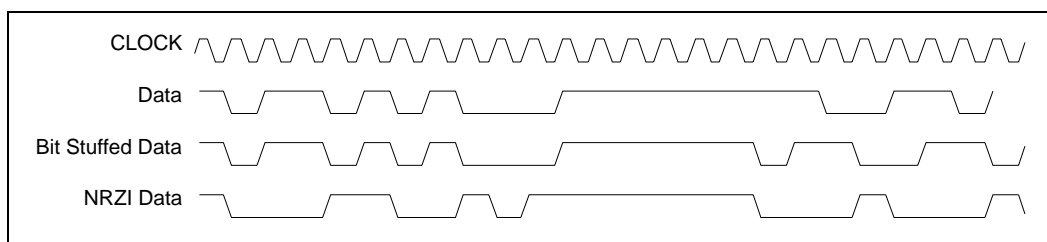

Bit stuffing is enabled beginning with the Sync Pattern and throughout the entire transmission. The data “one” that ends the Sync Pattern is counted as the first one in a sequence. Bit stuffing is always enforced, without exception. If required by the bit stuffing rules, a zero bit will be inserted even if it is the last bit before the end-of-packet (EOP) signal.

5.16.4 Bus Protocol

5.16.4.1 Bit Ordering

Bits are sent out onto the bus least significant bit (LSb) first, followed by next LSb, through to the most significant bit (MSb) last.

5.16.4.2 SYNC Field

All packets begin with a synchronization (SYNC) field, which is a coded sequence that generates a maximum edge transition density. The SYNC field appears on the bus as IDLE followed by the binary string “KJKJKJKK,” in its NRZI encoding. It is used by the input circuitry to align incoming data with the local clock and is defined to be eight bits in length. SYNC serves only as a synchronization mechanism and is not shown in the following packet diagrams. The last two bits in the SYNC field are a marker that is used to identify the first bit of the PID. All subsequent bits in the packet must be indexed from this point.

5.16.4.3 Packet Field Formats

Field formats for the token, data, and handshake packets are described in the following section. The effects of NRZI coding and bit stuffing have been removed for the sake of clarity. All packets have distinct start and end of packet delimiters.

Table 5-67. PID Format

Bit	Data Sent	Bit	Data Sent
0	PID 0	4	NOT(PID 0)
1	PID 1	5	NOT(PID 1)
2	PID 2	6	NOT(PID 2)
3	PID 3	7	NOT(PID 3)

Packet Identifier Field

A packet identifier (PID) immediately follows the SYNC field of every USB packet. A PID consists of a four bit packet type field followed by a four-bit check field as shown in [Table 5-67](#). The PID indicates the type of packet and, by inference, the format of the packet and the type of error detection applied to the packet. The four-bit check field of the PID insures reliable decoding of the PID so that the remainder of the packet is interpreted correctly. The PID check field is generated by performing a ones complement of the packet type field.

Any PID received with a failed check field or which decodes to a non-defined value is assumed to be corrupted and the remainder of the packet is assumed to be corrupted and is ignored by the receiver. PID types, codes, and descriptions are listed in [Table 5-68](#).

Table 5-68. PID Types

PID Type	PID Name	PID[3:0]	Description
Token	OUT	b0001	Address + endpoint number in host -> function transaction
	IN	b1001	Address + endpoint number in function -> host transaction
	SOF	b0101	Start of frame marker and frame number
	SETUP	b1101	Address + endpoint number in host -> function transaction for setup to a control endpoint
Data	DATA0	b0011	Data packet PID even
	DATA1	b1011	Data packet PID odd
Handshake	ACK	b0010	Receiver accepts error free data packet
	NAK	b1010	Rx device cannot accept data or Tx device cannot send data
	STALL	b1110	Endpoint is stalled
Special	PRE	b1100	Host-issued preamble. Enables downstream bus traffic to low speed devices.

PIDs are divided into four coding groups: token, data, handshake, and special, with the first two transmitted PID bits (PID[1:0]) indicating which group. This accounts for the distribution of PID codes.

5.16.4.4 Address Fields

Function endpoints are addressed using two fields: the function address field and the endpoint field.

Table 5-69. Address Field

Bit	Data Sent	Bit	Data Sent
0	ADDR 0	4	ADDR 4
1	ADDR 1	5	ADDR 5
2	ADDR 2	6	ADDR 6
3	ADDR 3		

Address Field

The function address (ADDR) field specifies the function, via its address, that is either the source or destination of a data packet, depending on the value of the token PID. As shown in [Table 5-69](#), a total of 128 addresses are specified as ADDR[6:0]. The ADDR field is specified for IN, SETUP, and OUT tokens.

Endpoint Field

An additional four-bit endpoint (ENDP) field, shown in [Table 5-70](#), permits more flexible addressing of functions in which more than one sub-channel is required. Endpoint numbers are function specific. The endpoint field is defined for IN, SETUP, and OUT token PIDs only.

Table 5-70. Endpoint Field

Bit	Data Sent
0	ENDP 0
1	ENDP 1
2	ENDP 2
3	ENDP 3

5.16.4.5 Frame Number Field

The frame number field is an 11-bit field that is incremented by the host on a per-frame basis. The frame number field rolls over upon reaching its maximum value of x7FFh, and is sent only for SOF tokens at the start of each frame.

5.16.4.6 Data Field

The data field may range from 0 to 1023 bytes and must be an integral numbers of bytes. Data bits within each byte are shifted out LSB first.

5.16.4.7 Cyclic Redundancy Check (CRC)

CRC is used to protect the all non-PID fields in token and data packets. In this context, these fields are considered to be protected fields. The PID is not included in the CRC check of a packet containing CRC. All CRCs are generated over their respective fields in the transmitter before bit stuffing is performed. Similarly, CRCs are decoded in the receiver after stuffed bits have been removed. Token and data packet CRCs provide 100% coverage for all single and double bit errors. A failed CRC is considered to indicate that one or more of the protected fields is corrupted and causes the receiver to ignore those fields, and, in most cases, the entire packet.

5.16.5 Packet Formats

5.16.5.1 Token Packets

Table 5-71 shows the field formats for a token packet. A token consists of a PID, specifying either IN, OUT, or SETUP packet type, and ADDR and ENDP fields. For OUT and SETUP transactions, the address and endpoint fields uniquely identify the endpoint that will receive the subsequent data packet. For IN transactions, these fields uniquely identify which endpoint should transmit a data packet. Only the ICH4 can issue token packets. IN PIDs define a data transaction from a function to the ICH4. OUT and SETUP PIDs define data transactions from the ICH4 to a function.

Token packets have a five-bit CRC that covers the address and endpoint fields as shown above. The CRC does not cover the PID, which has its own check field. Token and SOF packets are delimited by an EOP after three bytes of packet field data. If a packet decodes as an otherwise valid token or SOF but does not terminate with an EOP after three bytes, it must be considered invalid and ignored by the receiver.

Table 5-71. Token Format

Packet	Width
PID	8 bits
ADDR	7 bits
ENDP	4 bits
CRC5	5 bits

5.16.5.2 Start of Frame Packets

Table 5-72 shows a start of frame (SOF) packet. SOF packets are issued by the host at a nominal rate of once every 1.00 ms 0.05. SOF packets consist of a PID indicating packet type followed by an 11-bit frame number field.

The SOF token comprises the token-only transaction that distributes a start of frame marker and accompanying frame number at precisely timed intervals corresponding to the start of each frame. All full speed functions, including hubs, must receive and decode the SOF packet. The SOF token does not cause any receiving function to generate a return packet; therefore, SOF delivery to any given function cannot be guaranteed. The SOF packet delivers two pieces of timing information. A function is informed that a start of frame has occurred when it detects the SOF PID. Frame timing sensitive functions, which do not need to keep track of frame number, need only decode the SOF PID; they can ignore the frame number and its CRC. If a function needs to track frame number, it must comprehend both the PID and the time stamp.

Table 5-72. SOF Packet

Packet	Width
PID	8 bits
Frame Number	11 bits
CRC5	5 bits

5.16.5.3 Data Packets

A data packet consists of a PID, a data field, and a CRC as shown in Table 5-73. There are two types of data packets, identified by differing PIDs: DATA0 and DATA1. Two data packet PIDs are defined to support data toggle synchronization.

Data must always be sent in integral numbers of bytes. The data CRC is computed over only the data field in the packet and does not include the PID, which has its own check field.

Table 5-73. Data Packet Format

Packet	Width
PID	8 bits
DATA	0–1023 bytes
CRC16	16 bits

5.16.5.4 Handshake Packets

Handshake packets consist of only a PID. Handshake packets are used to report the status of a data transaction and can return values indicating successful reception of data, flow control, and stall conditions. Only transaction types that support flow control can return handshakes. Handshakes are always returned in the handshake phase of a transaction and may be returned, instead of data, in the data phase. Handshake packets are delimited by an EOP after one byte of packet field. If a packet is decoded as an otherwise valid handshake but does not terminate with an EOP after one byte, it must be considered invalid and ignored by the receiver.

There are three types of handshake packets:

- **ACK** indicates that the data packet was received without bit stuff or CRC errors over the data field and that the data PID was received correctly. An ACK handshake is applicable only in transactions in which data has been transmitted and where a handshake is expected. ACK can be returned by the host for IN transactions and by a function for OUT transactions.
- **NAK** indicates that a function was unable to accept data from the host (OUT) or that a function has no data to transmit to the host (IN). NAK can only be returned by functions in the data phase of IN transactions or the handshake phase of OUT transactions. The host can never issue a NAK. NAK is used for flow control purposes to indicate that a function is temporarily unable to transmit or receive data, but will eventually be able to do so without need of host intervention. NAK is also used by interrupt endpoints to indicate that no interrupt is pending.
- **STALL** is returned by a function in response to an IN token or after the data phase of an OUT. STALL indicates that a function is unable to transmit or receive data, and that the condition requires host intervention to remove the stall. Once a function's endpoint is stalled, the function must continue returning STALL until the condition causing the stall has been cleared through host intervention. The host is not permitted to return a STALL under any condition.

5.16.5.5 Handshake Responses

IN Transaction

A function may respond to an IN transaction with a STALL or NAK. If the token received was corrupted, the function will issue no response. If the function can transmit data, it will issue the data packet. The ICH4, as the USB host, can return only one type of handshake on an IN transaction, an ACK. If it receives a corrupted data, or cannot accept data due to a condition such as an internal buffer overrun, it discards the data and issues no response.

OUT Transaction

A function may respond to an OUT transaction with a STALL, ACK, or NAK. If the transaction contained corrupted data, it will issue no response.

SETUP Transaction

Setup defines a special type of host to function data transaction which permits the host to initialize an endpoint's synchronization bits to those of the host. Upon receiving a Setup transaction, a function must accept the data. Setup transactions cannot be STALLED or NAKed and the receiving function must accept the Setup transfer's data. If a non-control endpoint receives a SETUP PID, it must ignore the transaction and return no response.

5.16.6 USB Interrupts

There are two general groups of USB interrupt sources, those resulting from execution of transactions in the schedule, and those resulting from an ICH4 operation error. All transaction-based sources can be masked by software through the ICH4's Interrupt Enable register. Additionally, individual transfer descriptors can be marked to generate an interrupt on completion.

When the ICH4 drives an interrupt for USB, it internally drives the PIRQ[A]# pin for USB function #0, PIRQ[D]# pin for USB function #1, and the PIRQ[C]# pin for USB function #2, until all sources of the interrupt are cleared. To accommodate some operating systems, the Interrupt Pin register must contain a different value for each function of this new multi-function device.

5.16.6.1 Transaction Based Interrupts

These interrupts are not signaled until after the status for the last complete transaction in the frame has been written back to host memory. This guarantees that software can safely process through (Frame List Current Index -1) when it is servicing an interrupt.

CRC Error / Time-Out

A CRC/Time-Out error occurs when a packet transmitted from the ICH4 to a USB device or a packet transmitted from a USB device to the ICH4 generates a CRC error. The ICH4 is informed of this event by a time-out from the USB device or by the ICH4's CRC checker generating an error on reception of the packet. Additionally, a USB bus time-out occurs when USB devices do not respond to a transaction phase within 19-bit times of an EOP. Either of these conditions will cause the C_ERR field of the TD to decrement.

When the C_ERR field decrements to zero, the following occurs:

- The Active bit in the TD is cleared
- The Stalled bit in the TD is set
- The CRC/Time-out bit in the TD is set.
- At the end of the frame, the USB Error Interrupt bit is set in the HC status register.

If the CRC/Time out interrupt is enabled in the Interrupt Enable register, a hardware interrupt will be signaled to the system.

Interrupt on Completion

Transfer Descriptors contain a bit that can be set to cause an interrupt on their completion. The completion of the transaction associated with that block causes the USB Interrupt bit in the HC Status Register to be set at the end of the frame in which the transfer completed. When a TD is encountered with the IOC bit set to 1, the IOC bit in the HC Status register is set to 1 at the end of the frame if the active bit in the TD is set to 0 (even if it was set to zero when initially read).

If the IOC Enable bit of Interrupt Enable register (bit 2 of I/O offset 04h) is set, a hardware interrupt is signaled to the system. The USB Interrupt bit in the HC status register is set either when the TD completes successfully or because of errors. If the completion is because of errors, the USB Error bit in the HC status register is also set.

Short Packet Detect

A transfer set is a collection of data which requires more than 1 USB transaction to completely move the data across the USB. An example might be a large print file which requires numerous TDs in multiple frames to completely transfer the data. Reception of a data packet that is less than the endpoint's Max Packet size during Control, Bulk or Interrupt transfers signals the completion of the transfer set, even if there are active TDs remaining for this transfer set. Setting the SPD bit in a TD indicates to the HC to set the USB Interrupt bit in the HC status register at the end of the frame in which this event occurs. This feature streamlines the processing of input on these transfer types. If the Short Packet Interrupt Enable bit in the Interrupt Enable register is set, a hardware interrupt is signaled to the system at the end of the frame where the event occurred.

Serial Bus Babble

When a device transmits on the USB for a time greater than its assigned Max Length, it is said to be babbling. Since isochrony can be destroyed by a babbling device, this error results in the Active bit in the TD being cleared to 0 and the Stalled and Babble bits being set to one. The C_ERR field is not decremented for a babble. The USB Error Interrupt bit in the HC Status register is set to 1 at the end of the frame. A hardware interrupt is signaled to the system.

If an EOF babble was caused by the ICH4 (due to incorrect schedule for instance), the ICH4 will force a bit stuff error followed by an EOP and the start of the next frame.

Stalled

This event indicates that a device/endpoint returned a STALL handshake during a transaction or that the transaction ended in an error condition. The TDs Stalled bit is set and the Active bit is cleared. Reception of a STALL does not decrement the error counter. A hardware interrupt is signaled to the system.

Data Buffer Error

This event indicates that an overrun of incoming data or a under-run of outgoing data has occurred for this transaction. This would generally be caused by the ICH4 not being able to access required data buffers in memory within necessary latency requirements. Either of these conditions will cause the C_ERR field of the TD to be decremented.

When C_ERR decrements to zero, the Active bit in the TD is cleared, the Stalled bit is set, the USB Error Interrupt bit in the HC Status register is set to 1 at the end of the frame and a hardware interrupt is signaled to the system.

Bit Stuff Error

A bit stuff error results from the detection of a sequence of more than 6 ones in a row within the incoming data stream. This will cause the C_ERR field of the TD to be decremented. When the C_ERR field decrements to zero, the Active bit in the TD is cleared to 0, the Stalled bit is set to 1, the USB Error Interrupt bit in the HC Status register is set to 1 at the end of the frame and a hardware interrupt is signaled to the system.

5.16.6.2 Non-Transaction Based Interrupts

If an ICH4 process error or system error occur, the ICH4 halts and immediately issues a hardware interrupt to the system.

Resume Received

This event indicates that the ICH4 received a RESUME signal from a device on the USB bus during a global suspend. If this interrupt is enabled in the Interrupt Enable register, a hardware interrupt will be signaled to the system allowing the USB to be brought out of the suspend state and returned to normal operation.

Intel® ICH4 Process Error

The HC monitors certain critical fields during operation to ensure that it does not process corrupted data structures. These include checking for a valid PID and verifying that the MaxLength field is less than 1280. If it detects a condition that would indicate that it is processing corrupted data structures, it immediately halts processing, sets the HC Process Error bit in the HC Status register and signals a hardware interrupt to the system.

This interrupt cannot be disabled through the Interrupt Enable register.

Host System Error

The ICH4 sets this bit to 1 when a PCI Parity error, PCI Master Abort, or PCI Target Abort occur. When this error occurs, the ICH4 clears the Run/Stop bit in the Command register to prevent further execution of the scheduled TDs. This interrupt cannot be disabled through the Interrupt Enable register.

5.16.7 USB Power Management

The Host controller can be put into a suspended state and its power can be removed. This requires that certain bits of information are retained in the resume power plane of the ICH4 so that a device on a port may wake the system. Such a device may be a fax-modem, which will wake up the machine to receive a fax or take a voice message. The settings of the following bits in I/O space will be maintained when the ICH4 enters the S3, S4 or S5 states:

Table 5-74. Bits Maintained in Low Power States

Register	Offset	Bit	Description
Command	00h	3	Enter Global Suspend Mode (EGSM)
Status	02h	2	Resume Detect
Port Status and Control	10h & 12h	2	Port Enabled/Disabled
		6	Resume Detect
		8	Low Speed Device Attached
		12	Suspend

When the ICH4 detects a resume event on any of its ports, it will set the corresponding USB_STS bit in ACPI space. If USB is enabled as a wake/break event, the system will wake up and an SCI will be generated.

5.16.8 USB Legacy Keyboard Operation

When a USB keyboard is plugged into the system, and a standard keyboard is not, the system may not boot, and DOS legacy software will not run, because the keyboard will not be identified. The ICH4 implements a series of trapping operations which will snoop accesses that go to the keyboard controller, and put the expected data from the USB keyboard into the keyboard controller.

Note: The scheme described below assumes that the keyboard controller (8042 or equivalent) is on the LPC bus.

This legacy operation is performed through SMM space. [Figure 5-18](#) shows the Enable and Status path. The latched SMI source (60R, 60W, 64R, 64W) is available in the Status Register. Because the enable is after the latch, it is possible to check for other events that didn't necessarily cause an SMI. It is the software's responsibility to logically AND the value with the appropriate enable bits.

Note also that the SMI is generated before the PCI cycle completes (e.g., before TRDY# goes active) to ensure that the processor does not complete the cycle before the SMI is observed. This method is used on MPIIX and has been validated.

The logic will also need to block the accesses to the 8042. If there is an external 8042, then this is simply accomplished by not activating the 8042 CS. This is simply done by logically ANDing the 4 enables (60R, 60W, 64R, 64W) with the 4 types of accesses to determine if 8042CS should go active. An additional term is required for the "Pass-through" case.

The state table for the diagram is shown in [Table 5-75](#).

Figure 5-18. USB Legacy Keyboard Enable and Status Paths

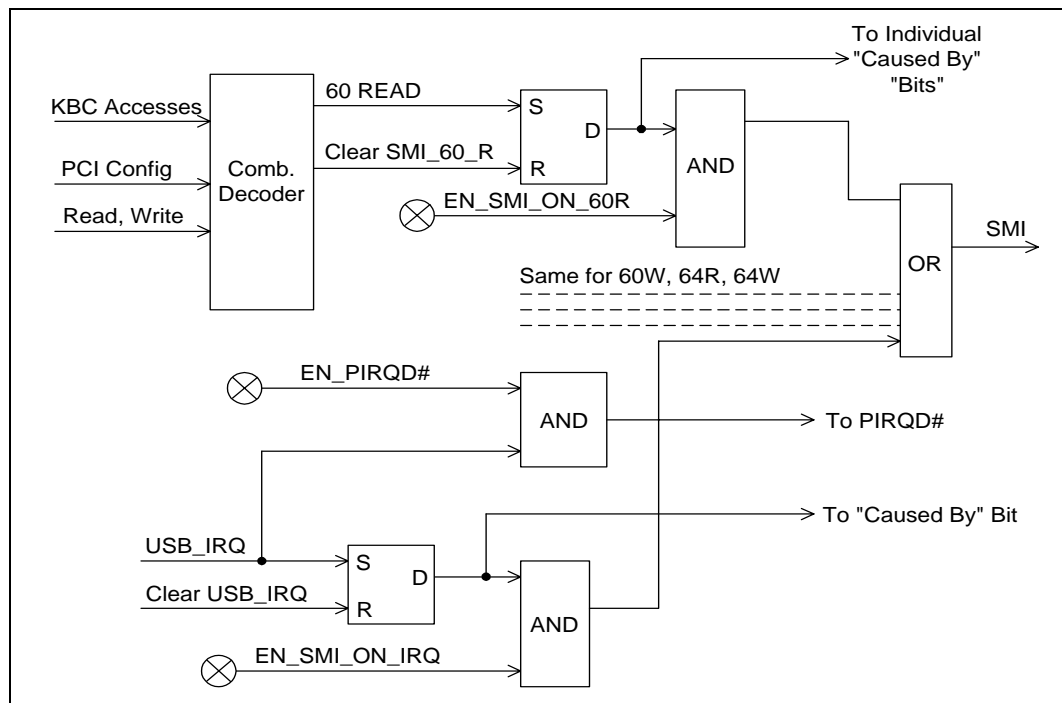

Table 5-75. USB Legacy Keyboard State Transitions

Current State	Action	Data Value	Next State	Comment
IDLE	64h / Write	D1h	GateState1	Standard D1 command. Cycle passed through to 8042. SMI# doesn't go active. PSTATE (offset C0, bit 6) goes to 1.
IDLE	64h / Write	Not D1h	IDLE	Bit 3 in configuration register determines if cycle passed through to 8042 and if SMI# generated.
IDLE	64h / Read	N/A	IDLE	Bit 2 in configuration register determines if cycle passed through to 8042 and if SMI# generated.
IDLE	60h / Write	Don't Care	IDLE	Bit 1 in configuration register determines if cycle passed through to 8042 and if SMI# generated.
IDLE	60h / Read	N/A	IDLE	Bit 0 in configuration register determines if cycle passed through to 8042 and if SMI# generated.
GateState1	60h / Write	XXh	GateState2	Cycle passed through to 8042, even if trap enabled in Bit 1 in configuration register. No SMI# generated. PSTATE remains 1. If data value is not DFh or DDh, then the 8042 may chose to ignore it.
GateState1	64h / Write	D1h	GateState1	Cycle passed through to 8042, even if trap enabled via Bit 3 in configuration register. No SMI# generated. PSTATE remains 1. Stay in GateState1 because this is part of the double-trigger sequence.
GateState1	64h / Write	Not D1h	IDLE	Bit 3 in configuration space determines if cycle passed through to 8042 and if SMI# generated. PSTATE goes to 0. If Bit 7 in Configuration register is set, then SMI# should be generated.
GateState1	60h / Read	N/A	IDLE	This is an invalid sequence. Bit 0 in configuration register determines if cycle passed through to 8042 and if SMI# generated. PSTATE goes to 0. If Bit 7 in configuration register is set, then SMI# should be generated.
GateState1	64h / Read	N/A	GateState1	Just stay in same state. Generate an SMI# if enabled in Bit 2 of configuration register. PSTATE remains 1.
GateState2	64 / Write	FFh	IDLE	Standard end of sequence. Cycle passed through to 8042. PSTATE goes to 0. Bit 7 in configuration space determines if SMI# should be generated.
GateState2	64h / Write	Not FFh	IDLE	Improper end of sequence. Bit 3 in the configuration register determines if cycle passed through to 8042 and if SMI# generated. PSTATE goes to 0. If Bit 7 in the configuration register is set, then SMI# should be generated.
GateState2	64h / Read	N/A	GateState2	Just stay in same state. Generate an SMI# if enabled in Bit 2 of configuration register. PSTATE remains 1.
GateState2	60h / Write	XXh	IDLE	Improper end of sequence. Bit 1 in the configuration register determines if cycle passed through to 8042 and if SMI# generated. PSTATE goes to 0. If Bit 7 in configuration register is set, then SMI# should be generated.
GateState2	60h / Read	N/A	IDLE	Improper end of sequence. Bit 0 in the configuration register determines if cycle passed through to 8042 and if SMI# generated. PSTATE goes to 0. If Bit 7 in configuration register is set, then SMI# should be generated.

5.17 USB EHCI Controller (D29:F7)

The ICH4 contains an Enhanced Host Controller Interface (EHCI) compliant host controller which supports up to six, high-speed USB 2.0 Specification compliant root ports. High-speed USB 2.0 allows data transfers up to 480 Mbps using the same pins as the 6 Full-speed/Low-speed USB UHCI ports. The ICH4 contains port-routing logic that determines whether a USB port is controlled by one of the UHCI controllers or by the EHCI controller. A USB 2.0 based Debug Port is also implemented in the ICH4.

A summary of the key architectural differences between the USB UHCI host controllers and the USB EHCI host controller are shown in [Table 5-66](#).

Table 5-76. UHCI vs. EHCI

	USB UHCI	USB EHCI
Accessible by	I/O space	Memory Space
Memory Data Structure	Single linked list	Separated in to Periodic and Asynchronous lists
Differential Signaling Voltage	3.3 V	400 mV
Ports per Controller	2	6

5.17.1 EHC Initialization

The following descriptions step through the expected ICH4 Enhanced Host Controller (EHC) initialization sequence in chronological order, beginning with a complete power cycle in which the suspend well and core well have been off.

5.17.1.1 Power On

The suspend well is a “deeper” power plane than the core well, which means that the suspend well is always functional when the core well is functional but the core well may not be functional when the suspend well is. Therefore, the suspend well reset pin (RSMRST#) deasserts before the core well reset pin (PWROK) rises.

1. The suspend well reset deasserts, leaving all registers and logic in the suspend well in the default state. However, it is not possible to read any registers until after the core well reset deasserts. Note that normally the suspend well reset will only occur when a system is unplugged. In other words, suspend well resets are not easily achieved by software or the end-user. This step will typically not occur immediately before the remaining steps.
2. The core well reset deasserts, leaving all registers and logic in the core well in the default state. The EHC configuration space is accessible at this point. Note that the core well reset can (and typically does) occur without the suspend well reset asserting. This means that all of the Configure Flag and Port Status and Control bits (and any other suspend-well logic) may be in any valid state at this time.

5.17.1.2 BIOS Initialization

BIOS performs a number of platform customization steps after the core well has powered up. Contact your intel field sales representative for the latest BIOS information.

5.17.1.3 Driver Initialization

See Chapter 4 of the *Enhanced Host Controller Interface Specification for Universal Serial Bus*.

5.17.1.4 EHC Resets

In addition to the standard ICH4 hardware resets, portions of the EHC are reset by the HCRESET bit and the transition from the D3hot device power management state to the D0 state. The effects of each of these resets are listed in the following table.

Reset	Does Reset	Does not Reset	Comments
HCRESET bit set	Memory space registers except Structural Parameters (which is written by BIOS)	Configuration registers	The HCRESET must only affect registers that the EHCI driver controls. PCI Configuration space and BIOS-programmed parameters can not be reset.
Software writes the Device Power State from D3hot (11b) to D0 (00b)	Core well registers (except BIOS-programmed registers)	Suspend well registers; BIOS-programmed core well registers	The D3-to-D0 transition must not cause wake information (suspend well) to be lost. It also must not clear BIOS-programmed registers because BIOS may not be invoked following the D3-to-D0 transition.

If the detailed register descriptions give exceptions to these rules, those exceptions override these rules. This summary is provided to help explain the reasons for the reset policies.

5.17.2 Data Structures in Main Memory

See Chapter 3 and Appendix B of the *Enhanced Host Controller Interface Specification for Universal Serial Bus* for details.

5.17.3 USB 2.0 Enhanced Host Controller DMA

The ICH4 USB 2.0 EHC implements three sources of USB packets. They are, in order of priority on USB during each microframe,

1. the USB 2.0 Debug Port (see Section USB 2.0 EHCI Based Debug Port),
2. the Periodic DMA engine, and
3. the Asynchronous DMA engine.

The ICH4 always performs any currently-pending debug port transaction at the beginning of a microframe, followed by any pending periodic traffic for the current microframe. If there is time left in the microframe, then the EHC performs any pending asynchronous traffic until the end of the microframe (EOF1). Note that the debug port traffic is only presented on one port (Port #0), while the other ports are idle during this time.

The following subsections describe the policies of the periodic and asynchronous DMA engines.

5.17.3.1 Periodic List Execution

The Periodic DMA engine contains buffering for two control structures (two transactions). By implementing two entries, the EHC is able to pipeline the memory accesses for the next transaction while executing the current transaction on the USB ports. Note that a multiple-packet, High-Bandwidth transaction occupies one of these buffer entries, which means that up to six, 1-KB data packets may be associated with the two buffered control structures.

5.17.3.1.1 Read Policies for Periodic DMA

The Periodic DMA engine performs reads for the following structures.

Memory Structure	Size (DWords)	Comments
Periodic Frame List entry	1	The EHC reads the entry for each microframe. The frame list is not internally cached across microframes.
iTD	23	Only the 64-bit addressing format is supported.
siTD	9	Only the 64-bit addressing format is supported.
qTD	13	Only the 64-bit addressing format is supported.
Queue Head	17	Only the 64-bit addressing format is supported.
Out Data	Up to 257	The ICH4 breaks large read requests down into smaller aligned read requests based on the setting of the Read Request Max Length field.
Frame Span Transversal Node	2	

The EHC Periodic DMA Engine (PDE) does not generate accesses to main memory unless all three of the following conditions are met.

- The HCHalted bit is 0 (memory space, offset 24h, bit 12). Software clears this bit indirectly by setting the RUN/STOP bit to 1.
- The Periodic Schedule Status bit is 1 (memory space, offset 24h, bit 14). Software sets this bit indirectly by setting the Periodic Schedule Enable Bit to 1.
- The Bus Master Enable bit is 1 (configuration space, offset 04h, bit 2).

Note: Prefetching is limited to the current and next microframes only.

Note: Once the PDE checks the length of a periodic packet against the remaining time in the microframe (late-start check) and decides that there is not enough time to run it on the wire, then the EHC switches over to run asynchronous traffic.

5.17.3.1.2 Write Policies for Periodic DMA

The Periodic DMA engine performs writes for the following reasons.

Memory Structure	Size (DWords)	Comments
iTD Status Write	1	Only the DWord that corresponds to the just-executed microframe's status is written. All bytes of the DWord are written.
siTD Status Write	3	DWords 0C:17h are written. IOC and Buffer Pointer fields are re-written with the original value.
Interrupt Queue Head Overlay	14	Only the 64-bit addressing format is supported. DWords 0C:43h are written.
Interrupt Queue Head Status Write	54	DWords 14:27h are written.
Interrupt qTD Status Write	3	DWords 04:0Fh are written. PID Code, IOC, Buffer Pointers, and Alt. Next qTD Pointers are re-written with the original value.
In Data	Up to 257	The ICH4 breaks data writes down into 16-DWord aligned chunks.

NOTES:

1. The Periodic DMA Engine (PDE) will only generate writes after a transaction is executed on USB.
2. Status writes are always performed after In Data writes for the same transaction.

5.17.3.2 Asynchronous List Execution

The Asynchronous DMA engine contains buffering for two control structures (two transactions). By implementing two entries, the EHC is able to pipeline the memory accesses for the next transaction while executing the current transaction on the USB ports.

5.17.3.2.1 Read Policies for Asynchronous DMA

The Asynchronous DMA engine performs reads for the following structures.

Memory Structure	Size (DW)	Comments
qTD	13	Only the 64-bit addressing format is supported.
Queue Head	17	Only the 64-bit addressing format is supported.
Out Data	Up to 129	The ICH4 breaks large read requests down in to smaller aligned read requests based on the setting of the Read Request Max Length field.

The EHC Asynchronous DMA Engine (ADE) does not generate accesses to main memory unless all four of the following conditions are met. (Note that the ADE may be active when the periodic schedule is actively executed, unlike the description in the EHCI specification; since the EHC contains independent DMA engines, the ADE may perform memory accesses interleaved with the PDE accesses.)

- The HCHalted bit is 0 (memory space, offset 24h, bit 12). Software clears this bit indirectly by setting the RUN/STOP bit to 1.
- The Asynchronous Schedule Status bit is 1 (memory space, offset 24h, bit 14). Software sets this bit indirectly by setting the Asynchronous Schedule Enable Bit to 1.
- The Bus Master Enable bit is 1 (configuration space, offset 04h, bit 2).
- The ADE is not sleeping due to the detection of an empty schedule. There is not one single bit that indicates this state. However, the sleeping state is entered when the Queue Head with the H bit set is encountered when the Reclamation bit in the USB EHCI Status register is 0.

Note: The ADE does not fetch data when a QH is encountered in the Ping state. An Ack handshake in response to the Ping results in the ADE writing the QH to the Out state, which results in the fetching and delivery of the Out Data on the next iteration through the asynchronous list.

Note: Once the ADE checks the length of an asynchronous packet against the remaining time in the microframe (late-start check) and decides that there is not enough time to run it on the wire, then the EHC stops all activity on the USB ports for the remainder of that microframe.

Note: Once the ADE detects an “empty” asynchronous schedule as described in Chapter 4 of the *Enhanced Host Controller Interface (EHCI) Specification for Universal Serial Bus*, it implements a waking mechanism like the one in the example. The amount of time that the ADE “sleeps” is $10 \mu\text{s} \pm 30 \text{ ns}$.

5.17.3.2.2 Write Policies for Asynchronous DMA

The Asynchronous DMA engine performs writes for the following reasons.

Memory Structure	Size (DWords)	Comments
Asynchronous Queue Head Overlay	14	Only the 64-bit addressing format is supported. DWords 0C:43h are written.
Asynchronous Queue Head Status Write	34	DWords 14:1Fh are written.
Asynchronous qTD Status Write	3	DWords 04:0Fh are written. PID Code, IOC, Buffer Pointer (Page 0), and Alt. Next qTD Pointers are re-written with the original value.
In Data	Up to 1297	The Intel [®] ICH4 breaks data writes down into 16 DWord aligned chunks.

NOTES:

1. The Asynchronous DMA Engine (ADE) will only generate writes after a transaction is executed on USB.
2. Status writes are always performed after In Data writes for the same transaction.

5.17.4 Data Encoding and Bit Stuffing

See Chapter 8 of the *Universal Serial Bus (USB) Specification, Revision 2.0*.

5.17.5 Packet Formats

See Chapter 8 of the *Universal Serial Bus (USB) Specification, Revision 2.0*.

5.17.6 USB EHCI Interrupts and Error Conditions

Section 4 of the EHCI specification goes into detail on the EHC interrupts and the error conditions that cause them. All error conditions that the EHC detects can be reported through the EHCI Interrupt status bits. Only ICH4-specific interrupt and error-reporting behavior is documented in this section. The EHCI Interrupts Section must be read first, followed by this section of the datasheet to fully comprehend the EHC interrupt and error-reporting functionality.

- Based on the EHC's buffer sizes and buffer management policies, the Data Buffer Error can never occur on the ICH4.
- Master Abort and Target Abort responses from hub interface on EHC-initiated read packets will be treated as Fatal Host Errors. The EHC halts when these conditions are encountered.
- The ICH4 may assert the interrupts which are based on the interrupt threshold as soon as the status for the last complete transaction in the interrupt interval has been posted in the internal write buffers. The requirement in the EHCI Specification (that the status is written to memory) is met internally, even though the write may not be seen on the hub interface before the interrupt is asserted.
- Since the ICH4 supports the 1024-element Frame List size, the Frame List Rollover interrupt occurs every 1024 milliseconds.
- The ICH4 delivers interrupts using PIRQ#[H].
- The ICH4 does not modify the CERR count on an Interrupt IN when the “Do Complete-Split” execution criteria are not met.
- For complete-split transactions in the Periodic list, the “Missed Microframe” bit does not get set on a control-structure-fetch that fails the late-start test. If subsequent accesses to that control structure do not fail the late-start test, then the “Missed Microframe” bit will get set and written back.

5.17.6.1 Aborts on USB EHCI-Initiated Memory Reads

If a read initiated by the EHC is aborted, the EHC treats it as a fatal host error. The following actions are taken when this occurs:

- The Host System Error status bit is set
- The DMA engines are halted after completing up to one more transaction on the USB interface
- If enabled (by the Host System Error Enable), an interrupt is generated
- If the status is Master Abort, the Received Master Abort bit in configuration space is set
- If the status is Target Abort, the Received Target Abort bit in configuration space is set
- If enabled (by the SERR Enable bit in the function's configuration space), the Signaled System Error bit in configuration bit is set.

5.17.7 USB EHCI Power Management

5.17.7.1 Pause Feature

This feature allows platforms (especially mobile systems) to dynamically enter low-power states during brief periods when the system is idle (i.e., between keystrokes). This is useful for enabling power management features like C3, C4, and Intel SpeedStep technology in the ICH4. The policies for entering these states typically are based on the recent history of system bus activity to incrementally enter deeper power management states. Normally, when the EHC is enabled, it regularly accesses main memory while traversing the DMA schedules looking for work to do; this activity is viewed by the power management software as a non-idle system, thus preventing the power managed states to be entered. Suspending all of the enabled ports can prevent the memory accesses from occurring, but there is an inherent latency overhead with entering and exiting the suspended state on the USB ports that makes this unacceptable for the purpose of dynamic power management. As a result, the EHCI software drivers are allowed to pause the EHC's DMA engines when it knows that the traffic patterns of the attached devices can afford the delay. The pause only prevents the EHC from generating memory accesses; the SOF packets continue to be generated on the USB ports (unlike the suspended state).

5.17.7.2 Suspend Feature

The *Enhanced Host Controller Interface (EHCI) for Universal Serial Bus Specification* describes the details of Port Suspend and Resume in detail in Section 4.3.

5.17.7.3 ACPI Device States

The USB EHCI function only supports the D0 and D3 PCI Power Management states. Notes regarding the ICH4 implementation of the Device States:

- The EHC hardware does not inherently consume any more power when it is in the D0 state than it does in the D3 state. However, software is required to suspend or disable all ports prior to entering the D3 state such that the maximum power consumption is reduced.
- In the D0 state, all implemented EHC features are enabled.
- In the D3 state, accesses to the EHC memory-mapped I/O range will master abort. Note that, since the Debug Port uses the same memory range, the Debug Port is only operational when the EHC is in the D0 state.
- In the D3 state, the EHC interrupt must never assert for any reason. The internal PME# signal is used to signal wake events, etc.
- When the Device Power State field is written to D0 from D3, an internal reset is generated. See section EHC Resets for general rules on the effects of this reset.
- Attempts to write any other value into the Device Power State field other than 00b (D0 state) and 11b (D3 state) will complete normally without changing the current value in this field.

5.17.7.4 ACPI System States

The EHC behavior as it relates to other power management states in the system is summarized in the following list:

- The System is always in the S0 state when the EHC is in the D0 state. However, when the EHC is in the D3 state, the system may be in any power management state (including S0).
- When in D0, the Pause feature (See Section 5.17.7.1) enables dynamic processor low-power states to be entered.
- The PLL in the EHC is disabled when entering the S3/S4/S5 states (core power turns off).
- All core well logic is reset in the S3/S4/S5 states (core power turns off).

5.17.8 Interaction with Classic Host Controllers

The EHC shares the six USB ports with three UHCI Host controllers in the ICH4. The USB UHCI controller at D29:F0 shares ports 0 and 1; the USB UHCI controller at D29:F1 shares ports 2 and 3; and the USB UHCI controller at D29:F2 shares ports 4 and 5 with the EHCI controller. There is very little interaction between the USB EHCI and the USB UHCI controllers other than the muxing control which is provided as part of the EHCI controller.

Figure 5-19 depicts the USB Port Connections at a conceptual level. The dashed rectangle indicates all of the logic that is part of the EHC cluster.

Figure 5-19. Intel® ICH4 USB Port Connections

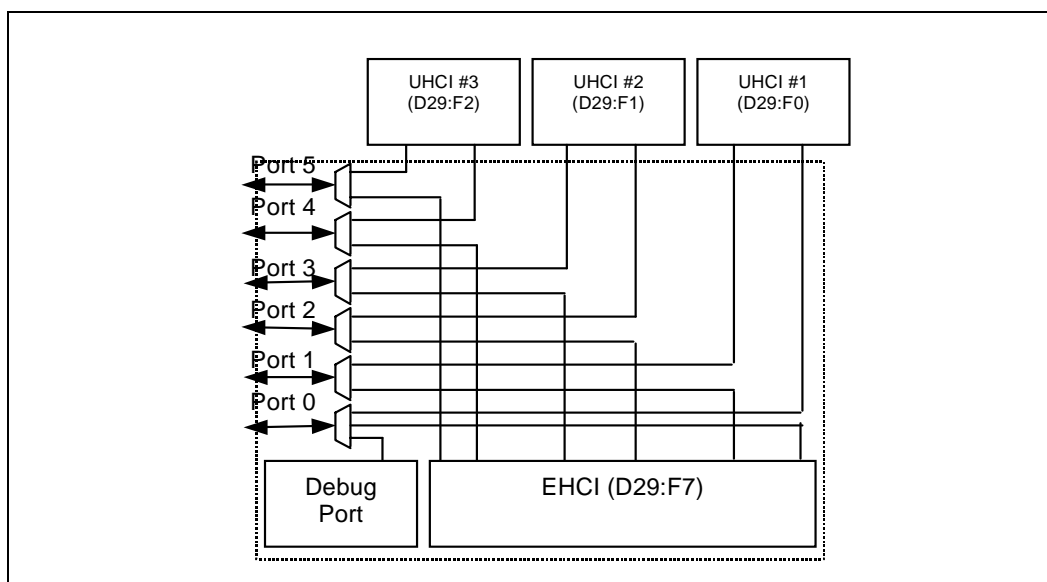

5.17.8.1 Port-Routing Logic

Integrated into the EHC functionality is port-routing logic, which performs the muxing between the USB UHCI and USB EHCI host controllers. The ICH4 conceptually implements this logic as described in Section 4.2 of the *Enhanced Host Controller Interface (EHCI) for Universal Serial Bus Specification*. If a device is connected that is not capable of USB 2.0's high-speed signaling protocol or if the EHCI software drivers are not present as indicated by the Configured Flag, then

the USB UHCI controller owns the port. Owning the port means that the differential output is driven by the owner and the input stream is only visible to the owner. The host controller that is not the owner of the port internally sees a disconnected port.

Note that the port-routing logic is the only block of logic within the ICH4 that observes the physical (real) connect/disconnect information. The port status logic inside each of the host controllers observes the electrical connect/disconnect information that is generated by the port-routing logic.

Only the differential signal pairs are muxed/demuxed between the USB UHCI and USB EHCI host controllers. The other USB functional signals are handled as follows:

- The Overcurrent inputs (OC#[5:0]) are directly routed to both controllers. An overcurrent event is recorded in both controller's status registers.

The Port-Routing logic is implemented in the Suspend power well so that re-enumeration and re-mapping of the USB ports is not required following entering and exiting a system sleep state in which the core power is turned off.

The ICH4 also allows the USB Debug Port traffic to be routed in and out of Port #0. When in this mode, the EHC is the owner of Port #0.

5.17.8.2 Device Connects

Section 4.2 of the *Enhanced Host Controller Interface (EHCI) for Universal Serial Bus Specification* describes the details of handling Device Connects. There are four general scenarios that are summarized below.

1. Configure Flag = 0 and a USB Full-speed/Low-speed -only Device is connected
 - In this case, the USB UHCI controller is the owner of the port both before and after the connect occurs. The EHC (except for the port-routing logic) never sees the connect occur. The UHCI driver handles the connection and initialization process.
2. Configure Flag = 0 and an USB High-speed-capable Device is connected
 - In this case, the USB UHCI controller is the owner of the port both before and after the connect occurs. The EHC (except for the port-routing logic) never sees the connect occur. The UHCI driver handles the connection and initialization process. Since the USB UHCI controller does not perform the high-speed chirp handshake, the device operates in compatible mode.
3. Configure Flag = 1 and a USB Full-speed/Low-speed-only Device is connected
 - In this case, the USB EHCI controller is the owner of the port before the connect occurs. The EHCI driver handles the connection and performs the port reset. After the reset process completes, the EHC hardware has cleared (not set) the Port Enable bit in the EHC's PORTSC register. The EHCI driver then writes a 1 to the Port Owner bit in the same register, causing the USB UHCI controller to see a connect event and the EHC to see an "electrical" disconnect event. The UHCI driver and hardware handle the connection and initialization process from that point on. The EHCI driver and hardware handle the perceived disconnect.
4. Configure Flag = 1 and an USB High-speed-capable Device is connected
 - In this case, the USB EHCI controller is the owner of the port before, and remains the owner after, the connect occurs. The EHCI driver handles the connection and performs the port reset. After the reset process completes, the EHC hardware has set the Port Enable bit in the EHC's PORTSC register. The port is functional at this point. The USB UHCI controller continues to see an unconnected port.

5.17.8.3 Device Disconnects

Section 4.2 of the *Enhanced Host Controller Interface (EHCI) for Universal Serial Bus Specification* describes the details of handling Device Connects. There are three general scenarios that are summarized below.

1. Configure Flag = 0 and the device is disconnected
 - In this case, the USB UHCI controller is the owner of the port both before and after the disconnect occurs. The EHC (except for the port-routing logic) never sees a device attached. The UHCI driver handles disconnection process.
2. Configure Flag = 1 and a USB Full-speed/Low-speed-capable Device is disconnected
 - In this case, the USB UHCI controller is the owner of the port before the disconnect occurs. The disconnect is reported by the USB UHCI controller and serviced by the associated UHCI driver. The port-routing logic in the EHC cluster forces the Port Owner bit to 0, indicating that the EHC owns the unconnected port.
3. Configure Flag = 1 and a USB High-speed-capable Device is disconnected
 - In this case, the USB EHCI controller is the owner of the port before, and remains the owner after, the disconnect occurs. The EHCI hardware and driver handle the disconnection process. The USB UHCI controller never sees a device attached.

5.17.8.4 Effect of Resets on Port-Routing Logic

As mentioned above, the Port Routing logic is implemented in the Suspend power well so that re-enumeration and re-mapping of the USB ports is not required following entering and exiting a system sleep state in which the core power is turned off.

Reset Event	Effect on Configure Flag	Effect on Port Owner Bits
Suspend Well Reset	cleared (0)	set (1)
Core Well Reset	no effect	no effect
D3-to-D0 Reset	no effect	no effect
HCRESET	cleared (0)	set (1)

5.17.9 USB 2.0 Legacy Keyboard Operation

The ICH4 must support the possibility of a keyboard downstream from either a USB UHCI or a USB EHCI port. The description of the legacy keyboard support is unchanged from USB UHCI (See [Section 5.16.8](#)).

The EHC provides the basic ability to generate SMIs on an interrupt event, along with more sophisticated control of the generation of SMIs.

5.17.10 USB 2.0 EHCI Based Debug Port

The ICH4 supports the elimination of the legacy COM ports by providing the ability for new debugger software to interact with devices on a USB EHCI port. High-level restrictions and features are:

- Must be operational before USB EHCI drivers are loaded.
- Must work even when the port is disabled.
- Must work even though non-configured port is default-routed to the classic controller. Note that the Debug Port can not be used to debug an issue that requires a classic USB device on Port #0 using the UHCI drivers.
- Must allow normal system USB EHCI traffic in a system that may only have one USB port.
- Debug Port device (DPD) must be High-Speed capable and connect to a High-Speed port on ICH4 systems.
- Debug Port FIFO must always make forward progress (a bad status on USB is simply presented back to software)
- The Debug Port FIFO is only given one USB access per microframe

The Debug port facilitates OS and device driver debug. It allows the software to communicate with an external console using a USB EHCI connection. Because the interface to this link does not go through the normal USB EHCI stack, it allows communication with the external console during cases where the OS is not loaded, the USB EHCI software is broken, or where the USB EHCI software is being debugged. Specific features of this implementation of a debug port are:

- Only works with an external USB 2.0 debug device (console)
- Implemented for a specific port on the host controller
- Operational anytime the port is not suspended AND the host controller is in D0 power state.
- Capability is interrupted when port is driving USB RESET

5.17.10.1 Theory of Operation

There are two operational modes for the USB debug port:

- Mode 1 is when the USB port is in a disabled state from the viewpoint of a standard host controller driver. In Mode 1, the Debug Port controller is required to generate a “keepalive” packets less than 2 ms apart to keep the attached debug device from suspending. The keepalive packet should be a standalone 32-bit SYNC field.
- Mode 2 is when the host controller is running (i.e., Host controller’s *Run/Stop#* bit is 1). In Mode 2, the normal transmission of SOF packets will keep the debug device from suspending.

Behavioral Rules

1. In both modes 1 and 2, the Debug Port controller must check for software requested debug transactions at least every 125 microseconds.
2. If the debug port is enabled by the debug driver, and the standard host controller driver resets the USB port, USB debug transactions are held off for the duration of the reset and until after the first SOF is sent.
3. If the standard host controller driver suspends the USB port, then USB debug transactions are held off for the duration of the suspend/resume sequence and until after the first SOF is sent.
4. The ENABLED_CNT bit in the debug register space is independent of the similar port control bit in the associated Port Status and Control register.

Table 5-77 shows the debug port behavior related to the state of bits in the debug registers as well as bits in the associated Port Status and Control register.

Table 5-77. Debug Port Behavior

OWNER_CNT	ENABLED_CT	Port Enable	Run / Stop	Suspend	Debug Port Behavior
0	X	X	X	X	Debug port is not being used. Normal operation.
1	0	X	X	X	Debug port is not being used. Normal operation.
1	1	0	0	X	Debug port in Mode 1. SYNC keepalives sent plus debug traffic
1	1	0	1	X	Debug port in Mode 2. SOF (and only SOF) is sent as keepalive. Debug traffic is also sent. Note that no other normal traffic is sent out this port, because the port is not enabled.
1	1	1	0	0	Illegal. Host controller driver should never put controller into this state (enabled, not running and not suspended).
1	1	1	0	1	Port is suspended. No debug traffic sent.
1	1	1	1	0	Debug port in Mode 2. Debug traffic is interspersed with normal traffic.
1	1	1	1	1	Port is suspended. No debug traffic sent.

5.17.10.1.1 OUT Transactions

An Out transaction sends data to the debug device. It can occur only when the following are true:

- The debug port is enabled
- The debug software sets the GO_CNT bit
- The WRITE_READ#_CNT bit is set

The sequence of the transaction is:

1. Software sets the appropriate values in the following bits:
 - USB_ADDRESS_CNF
 - USB_ENDPOINT_CNF
 - DATA_BUFFER[63:0]
 - TOKEN_PID_CNT[7:0]
 - SEND_PID_CNT[15:8]
 - DATA_LEN_CNT
 - WRITE_READ#_CNT (note: this will always be 1 for OUT transactions)
 - GO_CNT (note: this will always be 1 to initiate the transaction)

2. The debug port controller sends a token packet consisting of
 - SYNC
 - TOKEN_PID_CNT field
 - USB_ADDRESS_CNT field
 - USB_ENDPOINT_CNT field
 - 5-bit CRC field
3. After sending the token packet, the debug port controller sends a data packet consisting of
 - SYNC
 - SEND_PID_CNT field
 - The number of data bytes indicated in DATA_LEN_CNT from the DATA_BUFFER
 - 16-bit CRC

Note: A DATA_LEN_CNT value of zero is valid in which case no data bytes would be included in the packet.

4. After sending the data packet, the controller waits for a handshake response from the debug device.
 - If a handshake is received, the debug port controller:
 - a. Places the received PID in the RECEIVED_PID_STS field
 - b. Resets the ERROR_GOOD#_STS bit
 - c. Sets the DONE_STS bit
 - If no handshake PID is received, the debug port controller:
 - a. Sets the EXCEPTION_STS field to 001b
 - b. Sets the ERROR_GOOD#_STS bit
 - c. Sets the DONE_STS bit

5.17.10.1.2 IN Transactions

An IN transaction receives data from the debug device. It can occur only when the following are true:

- The debug port is enabled
- The debug software sets the GO_CNT bit
- The WRITE_READ#_CNT bit is reset

The sequence of the transaction is:

1. Software sets the appropriate values in the following bits:
 - USB_ADDRESS_CNF
 - USB_ENDPOINT_CNF
 - TOKEN_PID_CNT[7:0]
 - DATA_LEN_CNT
 - WRITE_READ#_CNT (note: this will always be 0 for IN transactions)
 - GO_CNT (note: this will always be 1 to initiate the transaction)

2. The debug port controller sends a token packet consisting of:
 - SYNC
 - TOKEN_PID_CNT field
 - USB_ADDRESS_CNT field
 - USB_ENDPOINT_CNT field
 - 5-bit CRC field.
3. After sending the token packet, the debug port controller waits for a response from the debug device.
If a response is received:
 - The received PID is placed into the RECEIVED_PID_STS field
 - Any subsequent bytes are placed into the DATA_BUFFER
 - The DATA_LEN_CNT field is updated to show the number of bytes that were received after the PID.
4. If valid packet was received from the device that was one byte in length (indicating it was a handshake packet), then the debug port controller:
 - Resets the ERROR_GOOD#_STS bit
 - Sets the DONE_STS bit
5. If valid packet was received from the device that was more than one byte in length (indicating it was a data packet), then the debug port controller:
 - Transmits an ACK handshake packet
 - Resets the ERROR_GOOD#_STS bit
 - Sets the DONE_STS bit
6. If no valid packet is received, then the debug port controller:
 - Sets the EXCEPTION_STS field to 001b
 - Sets the ERROR_GOOD#_STS bit
 - Sets the DONE_STS bit.

5.17.10.1.3 Debug Software

Enabling the Debug Port

There are two mutually exclusive conditions that debug software must address as part of its startup processing:

- The EHCI has been initialized by system software
- The EHCI has not been initialized by system software

Debug software can determine the current “initialized” state of the EHCI by examining the Configure Flag in the EHCI USB 2.0 Command Register. If this flag is set, then system software has initialized the EHCI. Otherwise, the EHCI should not be considered initialized. Debug software will initialize the debug port registers depending on the state the EHCI. However, before this can be accomplished, debug software must determine which root USB port is designated as the debug port.

Determining the Debug Port

Debug software can easily determine which USB root port has been designated as the debug port by examining bits 20:23 of the EHCI Host controller Structural Parameters register. This 4-bit field represents the numeric value assigned to the debug port (i.e., 0000=port 0).

Debug Software Startup with Non-Initialized EHCI

Debug software can attempt to use the debug port if after setting the OWNER_CNT bit, the Current Connect Status bit in the appropriate (See Determining the Debug Port) PORTSC register is set. If the Current Connect Status bit is not set, then debug software may choose to terminate or it may choose to wait until a device is connected.

If a device is connected to the port, then debug software must reset/enable the port. Debug software does this by setting and then clearing the Port Reset bit the PORTSC register. To guarantee a successful reset, debug software should wait at least 50 ms before clearing the Port Reset bit. Due to possible delays, this bit may not change to 0 immediately; reset is complete when this bit reads as 0. Software must not continue until this bit reads 0.

If a high-speed device is attached, the EHCI will automatically set the Port Enabled/Disabled bit in the PORTSC register and the debug software can proceed. Debug software should set the ENABLED_CNT bit in the Debug Port Control/Status register, and then reset (clear) the Port Enabled/Disabled bit in the PORTSC register (so that the system host controller driver does not see an enabled port when it is first loaded).

Debug Software Startup with Initialized EHCI

Debug software can attempt to use the debug port if the Current Connect Status bit in the appropriate (See Determining the Debug Port) PORTSC register is set. If the Current Connect Status bit is not set, then debug software may choose to terminate or it may choose to wait until a device is connected.

If a device is connected, then debug software must set the OWNER_CNT bit and then the ENABLED_CNT bit in the Debug Port Control/Status register.

Determining Debug Peripheral Presence

After enabling the debug port functionality, debug software can determine if a debug peripheral is attached by attempting to send data to the debug peripheral. If all attempts result in an error (Exception bits in the Debug Port Control/Status register indicates a Transaction Error), then the attached device is not a debug peripheral. If the debug port peripheral is not present, then debug software may choose to terminate or it may choose to wait until a debug peripheral is connected.

5.18 SMBus Controller Functional Description (D31:F3)

The ICH4 provides an SMBus 2.0 compliant Host controller as well as an SMBus Slave Interface. The Host controller provides a mechanism for the processor to initiate communications with SMBus peripherals (slaves). The ICH4 is also capable of operating in a mode in which it can communicate with I²C compatible devices.

The ICH4 can perform SMBus messages with either packet error checking (PEC) enabled or disabled. The actual PEC calculation and checking is performed in hardware by the ICH4.

The Slave Interface allows an external master to read from or write to the ICH4. Write cycles can be used to cause certain events or pass messages, and the read cycles can be used to determine the state of various status bits. The ICH4's internal Host controller cannot access the ICH4's internal Slave Interface.

The ICH4 SMBus logic exists in Device 31:Function 3 configuration space, and consists of a transmit data path and host controller. The transmit data path provides the data flow logic needed to implement the seven different SMBus command protocols and is controlled by the host controller. The ICH4 SMBus controller logic is clocked by RTC clock.

The SMBus Address Resolution Protocol (ARP) is supported by using the existing host controller commands through software, except for the new Host Notify command (which is actually a received message).

The programming model of the host controller is combined into two portions: a PCI configuration portion and a system I/O mapped portion. All static configuration (e.g., the I/O base address) is done via the PCI configuration space. Real-time programming of the Host interface is done in system I/O space.

5.18.1 Host Controller

The SMBus Host controller is used to send commands to other SMBus slave devices. Software sets up the host controller with an address, command, and, for writes, data and optional PEC; and then tells the controller to start. When the controller has finished transmitting data on writes, or receiving data on reads, it will generate an SMI# or interrupt, if enabled.

The host controller supports eight command protocols of the SMBus interface (see System Management Bus Specification): Quick Command, Send Byte, Receive Byte, Write Byte/Word, Read Byte/Word, Process Call, Block Read/Write, and Host Notify.

The SMBus Host controller requires that the various data and command fields be setup for the type of command to be sent. When software sets the START bit, the SMBus Host controller performs the requested transaction and interrupts the processor (or generate an SMI#) when the transaction is completed. Once a START command has been issued, the values of the "active registers" (Host Control, Host Command, Transmit Slave Address, Data 0, Data 1) should not be changed or read until the interrupt status bit (INTR) has been set (indicating the completion of the command). Any register values needed for computation purposes should be saved prior to issuing of a new command, as the SMBus Host controller will update all registers while completing the new command.

Using the SMB Host controller to send commands to the ICH4's SMB slave port is supported. The ICH4 supports slave functionality, including the Host Notify protocol, on the SMLink pins. Therefore, to be fully compliant with the SMBus 2.0 specification (which requires the Host Notify protocol), the SMLink and SMBus signals should be tied together externally.

5.18.1.1 Command Protocols

In all of the following commands, the Host Status Register (offset 00h) is used to determine the progress of the command. While the command is in operation, the HOST_BUSY bit is set. If the command completes successfully, the INTR bit will be set in the Host Status Register. If the device does not respond with an acknowledge, and the transaction times out, the DEV_ERR bit is set. If software sets the KILL bit in the Host Control Register while the command is running, the transaction will stop and the FAILED bit will be set.

Quick Command

When programmed for a Quick Command, the Transmit Slave Address Register is sent. The PEC byte is never appended to the Quick Protocol. Software should force the PEC_EN bit to 0 when performing the Quick Command. Software must force the I2C_EN bit to 0 when running this command. The format of the protocol is shown in [Table 5-78](#).

Table 5-78. Quick Protocol

Bit	Description
1	Start Condition
2–8	Slave Address - 7 bits
9	Read / Write Direction
10	Acknowledge from slave
11	Stop

Send Byte / Receive Byte

For the Send Byte command, the Transmit Slave Address and Device Command Registers are sent. For the Receive Byte command, the Transmit Slave Address Register is sent. The data received is stored in the DATA0 register. Software must force the I2C_EN bit to 0 when running this command.

The Receive Byte is similar to a Send Byte, the only difference is the direction of data transfer. The format of the protocol is shown in [Table 5-79](#), and [Table 5-80](#).

Table 5-79. Send / Receive Byte Protocol without PEC

Send Byte Protocol		Receive Byte Protocol	
Bit	Description	Bit	Description
1	Start	1	Start
2–8	Slave Address - 7 bits	2–8	Slave Address - 7 bits
9	Write	9	Read
10	Acknowledge from slave	10	Acknowledge from slave
11–18	Command code - 8 bits	11–18	Data byte from slave
19	Acknowledge from slave	19	NOT Acknowledge
20	Stop	20	Stop

Table 5-80. Send/Receive Byte Protocol with PEC

Send Byte Protocol		Receive Byte Protocol	
Bit	Description	Bit	Description
1	Start	1	Start
2–8	Slave Address - 7 bits	2–8	Slave Address - 7 bits
9	Write	9	Read
10	Acknowledge from slave	10	Acknowledge from slave
11–18	Command code - 8 bits	11–18	Data byte from slave
19	Acknowledge from slave	19	Acknowledge
20–27	PEC	20–27	PEC from slave
28	Acknowledge from slave	28	Not Acknowledge
29	Stop	29	Stop

Write Byte/Word

The first byte of a Write Byte/Word access is the command code. The next 1 or 2 bytes are the data to be written. When programmed for a Write Byte/Word command, the Transmit Slave Address, Device Command, and Data0 Registers are sent. In addition, the Data1 Register is sent on a Write Word command. Software must force the I2C_EN bit to 0 when running this command. The format of the protocol is shown in Table 5-81 and Table 5-82.

Table 5-81. Write Byte/Word Protocol without PEC

Write Byte Protocol		Write Word Protocol	
Bit	Description	Bit	Description
1	Start	1	Start
2–8	Slave Address - 7 bits	2–8	Slave Address - 7 bits
9	Write	9	Write
10	Acknowledge from slave	10	Acknowledge from slave
11–18	Command code - 8 bits	11–18	Command code - 8 bits
19	Acknowledge from slave	19	Acknowledge from slave
20–27	Data Byte - 8 bits	20–27	Data Byte Low - 8 bits
28	Acknowledge from Slave	28	Acknowledge from Slave
29	Stop	29–36	Data Byte High - 8 bits
		37	Acknowledge from slave
		38	Stop

Table 5-82. Write Byte/Word Protocol with PEC

Write Byte Protocol		Write Word Protocol	
Bit	Description	Bit	Description
1	Start	1	Start
2–8	Slave Address - 7 bits	2–8	Slave Address - 7 bits
9	Write	9	Write
10	Acknowledge from slave	10	Acknowledge from slave
11–18	Command code - 8 bits	11–18	Command code - 8 bits
19	Acknowledge from slave	19	Acknowledge from slave
20–27	Data Byte - 8 bits	20–27	Data Byte Low - 8 bits
28	Acknowledge from Slave	28	Acknowledge from Slave
29–36	PEC	29–36	Data Byte High - 8 bits
37	Acknowledge from Slave	37	Acknowledge from slave
38	Stop	38–45	PEC
		46	Acknowledge from slave
		47	Stop

Read Byte/Word

Reading data is slightly more complicated than writing data. First the ICH4 must write a command to the slave device. Then it must follow that command with a repeated start condition to denote a read from that device's address. The slave then returns 1 or 2 bytes of data. Software must force the I2C_EN bit to 0 when running this command.

When programmed for the read byte/word command, the Transmit Slave Address and Device Command Registers are sent. Data is received into the DATA0 on the read byte, and the DAT0 and DATA1 registers on the read word. The format of the protocol is shown in [Table 5-83](#) and [Table 5-84](#).

Table 5-83. Read Byte/Word Protocol without PEC

Read Byte Protocol		Read Word Protocol	
Bit	Description	Bit	Description
1	Start	1	Start
2–8	Slave Address - 7 bits	2–8	Slave Address - 7 bits
9	Write	9	Write
10	Acknowledge from slave	10	Acknowledge from slave
11–18	Command code - 8 bits	11–18	Command code - 8 bits
19	Acknowledge from slave	19	Acknowledge from slave
20	Repeated Start	20	Repeated Start
21–27	Slave Address - 7 bits	21–27	Slave Address - 7 bits
28	Read	28	Read
29	Acknowledge from slave	29	Acknowledge from slave
30–37	Data from slave - 8 bits	30–37	Data Byte Low from slave - 8 bits
38	NOT acknowledge	38	Acknowledge
39	Stop	39–46	Data Byte High from slave - 8 bits
		47	NOT acknowledge
		48	Stop

Table 5-84. Read Byte/Word Protocol with PEC

Read Byte Protocol		Read Word Protocol	
Bit	Description	Bit	Description
1	Start	1	Start
2–8	Slave Address - 7 bits	2–8	Slave Address - 7 bits
9	Write	9	Write
10	Acknowledge from slave	10	Acknowledge from slave
11–18	Command code - 8 bits	11–18	Command code - 8 bits
19	Acknowledge from slave	19	Acknowledge from slave
20	Repeated Start	20	Repeated Start
21–27	Slave Address - 7 bits	21–27	Slave Address - 7 bits
28	Read	28	Read
29	Acknowledge from slave	29	Acknowledge from slave
30–37	Data from slave - 8 bits	30–37	Data Byte Low from slave - 8 bits
38	Acknowledge	38	Acknowledge
39–46	PEC from slave	39–46	Data Byte High from slave - 8 bits
47	NOT Acknowledge	47	Acknowledge
48	Stop	48–55	PEC from slave
		56	NOT acknowledge
		57	Stop

Process Call

The process call is so named because a command sends data and waits for the slave to return a value dependent on that data. The protocol is simply a Write Word followed by a Read Word, but without a second command or stop condition.

When programmed for the Process Call command, the ICH4 transmits the Transmit Slave Address, Host Command, DATA0 and DATA1 registers. Data received from the device is stored in the DATA0 and DATA1 registers. The Process Call command with I2C_EN set and the PEC_EN bit set produces undefined results. Software must force either I2C_EN or PEC_EN to 0 when running this command. The format of the protocol is shown in [Table 5-85](#) and [Table 5-86](#).

Note: For process call command, the value written into bit 0 of the Transmit Slave Address Register (SMB I/O register, offset 04h) needs to be 0.

Table 5-85. Process Call Protocol without PEC

Bit	Description
1	Start
2–8	Slave Address - 7 bits
9	Write
10	Acknowledge from Slave
11–18 (Skip This step if I2C_EN bit set)	Command code - 8 bits
19 (Skip This step if I2C_EN bit set)	Acknowledge from slave
20–27	Data byte Low - 8 bits
28	Acknowledge from slave
29–36	Data Byte High - 8 bits
37	Acknowledge from slave
38	Repeated Start
39–45	Slave Address - 7 bits
46	Read
47	Acknowledge from slave
48–55	Data Byte Low from slave - 8 bits
56	Acknowledge
57–64	Data Byte High from slave - 8 bits
65	NOT acknowledge
66	Stop

Table 5-86. Process Call Protocol with PEC

Bit	Description
1	Start
2–8	Slave Address - 7 bits
9	Write
10	Acknowledge from Slave
11–18	Command code - 8 bits
19	Acknowledge from slave
20–27	Data byte Low - 8 bits
28	Acknowledge from slave
29–36	Data Byte High - 8 bits
37	Acknowledge from slave
38	Repeated Start
39–45	Slave Address - 7 bits
46	Read
47	Acknowledge from slave
48–55	Data Byte Low from slave - 8 bits
56	Acknowledge
57–64	Data Byte High from slave - 8 bits
65	Acknowledge
66–73	PEC from slave
74	NOT acknowledge
75	Stop

Block Read/Write

The ICH4 contains a 32-byte buffer for read and write data which can be enabled by setting bit 1 of the Auxiliary Control register at offset 0Dh in I/O space, as opposed to a single byte of buffering. This 32-byte buffer is filled with write data before transmission, and filled with read data on reception. In the ICH4, the interrupt is generated only after a transmission or reception of 32 bytes, or when the entire byte count has been transmitted/received.

This requires the ICH4 to check the byte count field. Currently, the byte count field is transmitted but ignored by the hardware as software will end the transfer after all bytes it cares about have been sent or received.

For a Block Write software must either force the I2C_EN bit or both the PEC_EN and AAC bits to 0 when running this command.

SMBus mode: The block write begins with a slave address and a write condition. After the command code the ICH4 issues a byte count describing how many more bytes will follow in the message. If a slave had 20 bytes to send, the first byte would be the number 20 (14h), followed by 20 bytes of data. The byte count may not be 0. A Block Read or Write is allowed to transfer a maximum of 32 data bytes.

When programmed for a block write command, the Transmit Slave Address, Device Command, and Data0 (count) registers are sent. Data is then sent from the Block Data Byte register; the total data sent being the value stored in the Data0 Register. On block read commands, the first byte received is stored in the Data0 register, and the remaining bytes are stored in the Block Data Byte register.

The format of the Block Read/Write protocol is shown in [Table 5-87](#) and [Table 5-88](#).

Note: For Block Write, if the I2C_EN bit is set, the format of the command changes slightly. The ICH4 will still send the number of bytes (on writes) or receive the number of bytes (on reads) indicated in the DATA0 register. However, it will not send the contents of the DATA0 register as part of the message.

Table 5-87. Block Read/Write Protocol without PEC

Block Write Protocol		Block Read Protocol	
Bit	Description	Bit	Description
1	Start	1	Start
2–8	Slave Address - 7 bits	2–8	Slave Address - 7 bits
9	Write	9	Write
10	Acknowledge from slave	10	Acknowledge from slave
11–18	Command code - 8 bits	11–18	Command code - 8 bits
19	Acknowledge from slave	19	Acknowledge from slave
20–27	Byte Count - 8 bits	20	Repeated Start
28	Acknowledge from Slave	21–27	Slave Address - 7 bits
29–36	Data Byte 1 - 8 bits	28	Read
37	Acknowledge from Slave	29	Acknowledge from slave
38–45	Data Byte 2 - 8 bits	30–37	Byte Count from slave - 8 bits
46	Acknowledge from slave	38	Acknowledge
...	Data Bytes / Slave Acknowledges...	39–46	Data Byte 1 from slave - 8 bits
...	Data Byte N - 8 bits	47	Acknowledge
...	Acknowledge from Slave	48–55	Data Byte 2 from slave - 8 bits
...	Stop	56	Acknowledge
		...	Data Bytes from slave/Acknowledge
		...	Data Byte N from slave - 8 bits
		...	NOT Acknowledge
		...	Stop

Table 5-88. Block Read/Write Protocol with PEC

Block Write Protocol		Block Read Protocol	
Bit	Description	Bit	Description
1	Start	1	Start
2–8	Slave Address - 7 bits	2–8	Slave Address - 7 bits
9	Write	9	Write
10	Acknowledge from slave	10	Acknowledge from slave
11–18	Command code - 8 bits	11–18	Command code - 8 bits
19	Acknowledge from slave	19	Acknowledge from slave
20–27	Byte Count - 8 bits (Skip this step if I2C_EN bit set)	20	Repeated Start
28	Acknowledge from Slave (Skip this step if I2C_EN bit set)	21–27	Slave Address - 7 bits
29–36	Data Byte 1 - 8 bits	28	Read
37	Acknowledge from Slave	29	Acknowledge from slave
38–45	Data Byte 2 - 8 bits	30–37	Byte Count from slave - 8 bits
46	Acknowledge from slave	38	Acknowledge
...	Data Bytes / Slave Acknowledges...	39–46	Data Byte 1 from slave - 8 bits
...	Data Byte N - 8 bits	47	Acknowledge
...	Acknowledge from Slave	48–55	Data Byte 2 from slave - 8 bits
...	PEC - 8 bits	56	Acknowledge
...	Acknowledge from Slave	...	Data Bytes from slave/Acknowledge
...	Stop	...	Data Byte N from slave - 8 bits
		...	Acknowledge
		...	PEC from slave - 8 bits
		...	NOT Acknowledge
		...	Stop

I²C Read

This command allows the ICH4 to perform block reads to certain I²C devices (e.g., serial E²PROMs) in 10-bit addressing mode only. The SMBus Block Read sends both the 7-bit address, as well as the Command field. This command field could be used as the extended 10-bit address for accessing I²C devices that use 10-bit addressing.

However, this does not allow access to devices using the I²C “Combined Format” that has data bytes after the address. Typically these data bytes correspond to an offset (address) within the serial memory chips.

Note: This command is supported independent of the setting of the I2C_EN bit. The I²C Read command with the PEC_EN bit set produces undefined results. Software must force both the PEC_EN and AAC bit to 0 when running this command.

For I²C Read command, the value written into bit 0 of the Transmit Slave Address Register (SMB I/O register, offset 04h) needs to be 0. The format that is used for the new command is shown in Table 5-89.

Table 5-89. I²C Block Read

Bit	Description
1	Start
2–8	Slave Address - 7 bits
9	Write
10	Acknowledge from slave
11–18	Command code - 8 bits
19	Acknowledge from slave
20–27	Send DATA0 register
28	Acknowledge from slave
29–36	Send DATA1 register
37	Acknowledge from slave
38	Repeated start
39–45	Slave Address - 7 bits
46	Read
47	Acknowledge from slave
48–55	Data byte from slave
56	Acknowledge
57–64	Data byte 2 from slave - 8 bits
65	Acknowledge
—	Data bytes from slave / Acknowledge
—	Data byte N from slave - 8 bits
—	NOT Acknowledge
—	Stop

The ICH4 will continue reading data from the peripheral until the NAK is received.

5.18.1.2 I²C Behavior

When the I2C_EN bit is set, the ICH4 SMBus logic will instead be set to communicate with I²C devices. This forces the following changes:

- The Process Call command will skip the Command code (and its associated acknowledge)
- The Block Write command will skip sending the Byte Count (DATA0)

In addition, the ICH4 will support the new I²C Read command. This is independent of the I2C_EN bit.

Note: When operating in I²C mode the ICH4 will not use the 32-byte buffer for block commands.

5.18.1.3 Heartbeat for Use with the External LAN Controller

This method allows the ICH4 to send messages to an **external** LAN controller when the processor is otherwise unable to do so. It uses the SMLINK interface between the ICH4 and the external LAN controller. The actual Heartbeat message is a Block Write. Only 8 bytes are sent.

5.18.2 Bus Arbitration

Several masters may attempt to get on the bus at the same time by driving the SMBDATA line low to signal a start condition. The ICH4 must continuously monitor the SMBDATA line. When the ICH4 is attempting to drive the bus to a 1 by letting go of the SMBDATA line, and it samples SMBDATA low, some other master is driving the bus and the ICH4 must stop transferring data.

If the ICH4 sees that it has lost arbitration, the condition is called a collision. The ICH4 will set the BUS_ERR bit in the Host Status Register, and if enabled, generate an interrupt or SMI#. The processor is responsible for restarting the transaction.

When the ICH4 is a SMBus master, it will drive the clock. When the ICH4 is sending address or command as an SMBus master, or data bytes as a master on writes, it will drive data relative to the clock it is also driving. It will not start toggling the clock until the start or stop condition meets proper setup and hold time. The ICH4 will also guarantee minimum time between SMBus transactions as a master.

Note: The ICH4 supports the same arbitration protocol for both the SMBus and the System Management (SMLINK) interfaces.

5.18.3 Bus Timing

5.18.3.1 Clock Stretching

Some devices may not be able to handle their clock toggling at the rate that the ICH4 as an SMBus master would like. They have the capability of stretching the low time of the clock. When the ICH4 attempts to release the clock (allowing the clock to go high), the clock will remain low for an extended period of time.

The ICH4 must monitor the SMBus clock line after it releases the bus to determine whether to enable the counter for the high time of the clock. While the bus is still low, the high time counter must not be enabled. Similarly, the low period of the clock can be stretched by an SMBus master if it is not ready to send or receive data.

5.18.3.2 Bus Time Out (ICH4 as SMBus Master)

If there is an error in the transaction such that an SMBus device does not signal an acknowledge or holds the clock lower than the allowed time-out time, the transaction will time out. The ICH4 discards the cycle and sets the DEV_ERR bit. The time-out minimum is 25 ms. The time-out counter inside the ICH4 will start after the last bit of data is transferred by the ICH4 and it is waiting for a response. The 25 ms is a count of 800 RTC clocks.

5.18.4 Interrupts / SMI#

The ICH4 SMBus controller uses PIRQB# as its interrupt pin. However, the system can alternatively be set up to generate SMI# instead of an interrupt, by setting the SMBUS_SMI_EN bit.

Table 5-91 and Table 5-92 specify how the various enable bits in the SMBus function control the generation of the interrupt, Host and Slave SMI, and Wake internal signals. The rows in the tables are additive, which means that if more than one row is true for a particular scenario then the Results for all of the activated rows will occur.

Table 5-90. Enable for SMBALERT#

Event	INTREN (Host Control I/O Register, Offset 02h, Bit 0)	SMB_SMI_EN (Host Configuration Register, D31:F3:Offset 40h, Bit 1)	SMBALERT_DIS (Slave Command I/O Register, Offset 11h, Bit 2)	Result
SMBALERT# asserted low (always reported in Host Status Register, Bit 5)	X	X	X	Wake generated
	X	1	0	Slave SMI# generated (SMBUS_SMI_STS)
	1	0	0	Interrupt generated

Table 5-91. Enables for SMBus Slave Write and SMBus Host Events

Event	INTREN (Host Control I/O Register, Offset 02h, Bit 0)	SMB_SMI_EN (Host Configuration Register, D31:F3:Offset 40h, Bit1)	Event
Slave Write to Wake/ SMI# Command	X	X	Wake generated when asleep. Slave SMI# generated when awake (SMBUS_SMI_STS).
Slave Write to SMLINK_SLAVE_SMI Command	X	X	Slave SMI# generated when in the S0 state (SMBUS_SMI_STS)
Any combination of Host Status Register [4:1] asserted	0	X	None
	1	0	Interrupt generated
	1	1	Host SMI# generated

Table 5-92. Enables for the Host Notify Command

HOST_NOTIFY_INTREN (Slave Control I/O Register, Offset 11h, bit 0)	SMB_SMI_EN (Host Configuration Register, D31:F3:Off40h, Bit 1)	HOST_NOTIFY_WKEN (Slave Control I/O Register, Offset 11h, bit 1)	Result
0	X	0	None
X	X	1	Wake generated
1	0	X	Interrupt generated
1	1	X	Slave SMI# generated (SMBUS_SMI_STS)

5.18.5 SMBALERT#

SMBALERT# is multiplexed with GPIO[11]. When enable and the signal is asserted, The ICH4 can generate an interrupt, an SMI# or a wake event from S1–S5.

Note: Any event on SMBALERT# (regardless whether it is programmed as a GPIO or not), causes the event message to be sent in “heartbeat mode.”

5.18.6 SMBus CRC Generation and Checking

If the AAC bit is set in the Auxiliary Control register, the ICH4 automatically calculates and drives CRC at the end of the transmitted packet for write cycles and checks the CRC for read cycles. It will not transmit the contents of the PEC register for CRC. The PEC bit must not be set in the Host Control register if this bit is set, or unspecified behavior will result.

If the read cycle results in a CRC error, the DEV_ERR bit and the CRCE bit in the Auxiliary Status register at offset 0Ch will be set.

5.18.7 SMBus Slave Interface

The ICH4’s SMBus Slave interface is accessed via the SMLINK[1:0] signals. The SMBus slave logic does not generate or handle receiving the PEC byte and only acts as a Legacy Alerting Protocol (Alert on LAN) device. The slave interface allows the ICH4 to decode cycles, and allows an external microcontroller to perform specific actions. Key features and capabilities include:

- Supports decode of three types of messages: Byte Write, Byte Read, and Host Notify
- Receive Slave Address register: This is the address that the ICH4 decodes. A default value is provided so that the slave interface can be used without the processor having to program this register.
- Receive Slave Data register in the SMBus I/O space that includes the data written by the external microcontroller
- Registers that the external microcontroller can read to get the state of the ICH4. See [Table 5-97](#)
- Status bits to indicate that the SMLink/SMBus slave logic caused an interrupt or SMI# due to the reception of a message that matched the slave address.
 - Bit 0 of the Slave Status Register for the Host Notify command
 - Bit 16 of the SMI Status Register ([Section 9.8.3.10](#)) for all others

If a master leaves the clock and data bits of the SMLink interface at 1 for 50 μ s or more in the middle of a cycle, the ICH4 slave logic’s behavior is undefined. This is interpreted as an unexpected idle and should be avoided when performing management activities to the slave logic.

Note: When an external microcontroller accesses the SMBus Slave Interface over the SMLink a translation in the address is needed to accommodate the least significant bit used for read/write control. For example, if the ICH4 slave address (RCV_SLVA) is left at 44h (default), the external microcontroller would use an address of 88h/89h (write/read).

5.18.7.1 Format of Slave Write Cycle

The external master performs Byte Write commands to the ICH4 SMBus Slave interface. The “Command” field (bits 11–18) indicate which register is being accessed. The Data field (bits 20–27) indicate the value that should be written to that register.

The Write Cycle format is shown in [Table 5-93](#). [Table 5-94](#) provides the values associated with the registers.

Table 5-93. Slave Write Cycle Format

Bits	Description	Driven by	Comment
1	Start Condition	External Microcontroller	
2–8	Slave Address - 7 bits	External Microcontroller	Must match value in Receive Slave Address register
9	Write	External Microcontroller	Always 0
10	ACK	Intel® ICH4	
11–18	Command	External Microcontroller	This field indicates which register will be accessed. See Table 5-94 below for the register definitions
19	ACK	ICH4	
20–27	Register Data	External Microcontroller	See Table 5-94 below for the register definitions
28	ACK	ICH4	
29	Stop	External Microcontroller	

Table 5-94. Slave Write Registers

Register	Function
0	Command Register. See Table 5-95 for legal values written to this register.
1–3	Reserved
4	Data Message Byte 0
5	Data Message Byte 1
6–7	Reserved
8	Frequency Straps will be written on bits 3:0. Bits 7:4 should be 0, but will be ignored.
9–FFh	Reserved

NOTE: The external microcontroller is responsible to make sure that it does not update the contents of the data byte registers until they have been read by the system processor. The ICH4 will overwrite the old value with any new value received. A race condition is possible where the new value is being written to the register just at the time it is being read. ICH4 will not attempt to cover this race condition (i.e., unpredictable results in this case).

Table 5-95. Command Types

Command Type	Description
0	Reserved
1	WAKE/SMI#: Wake system if it is not already awake. If system is already awake, then an SMI# will be generated. NOTE: The SMB_WAK_STS bit will be set by this command, even if the system is already awake. The SMI handler should then clear this bit.
2	Unconditional Powerdown: This command sets the PWRBTNOR_STS bit, and has the same effect as the Powerbutton Override occurring.
3	HARD RESET WITHOUT CYCLING: The will cause a hard reset of the system (does not include cycling of the power supply). This is equivalent to a write to the CF9h register with bits 2:1 set to 1, but bit 3 set to 0.
4	HARD RESET SYSTEM: The will cause a hard reset of the system (including cycling of the power supply). This is equivalent to a write to the CF9h register with bits 3:1 set to 1.
5	Disable the TCO Messages: This command will disable the Intel® ICH4 from sending Heartbeat and Event messages (as described in Section 5.13.2). Once this command has been executed, Heartbeat and Event message reporting can only be re-enabled by assertion and deassertion of the RSMRST# signal.
6	WD RELOAD: Reload watchdog timer.
7	Reserved
8	SMLINK_SLV_SMI: When ICH4 detects this command type while in the S0 state, it sets the SMLINK_SLV_SMI_STS bit (see Section 9.9.7). This command should only be used if the system is in an S0 state. If the message is received during S1–S5 states, the ICH4 acknowledges it, but the SMLINK_SLV_SMI_STS bit does not get set. NOTE: It is possible that the system transitions out of the S0 state at the same time that the SMLINK_SLV_SMI command is received. In this case, the SMLINK_SLV_SMI_STS bit may get set but not serviced before the system goes to sleep. Once the system returns to S0, the SMI associated with this bit would then be generated. Software must be able to handle this scenario.
9–FFh	Reserved

5.18.7.2 Format of Read Command

The external master performs Byte Read commands to the ICH4 SMBus Slave interface. The “Command” field (bits 11–18) indicate which register is being accessed. The Data field (bits 30–37) contain the value that should be read from that register. [Table 5-96](#) shows the Read Cycle format. [Table 5-97](#) shows the register mapping for the data byte.

Table 5-96. Read Cycle Format

Bit	Description	Driven by:	Comment:
1	Start	External Microcontroller	
2–8	Slave Address – 7 bits	External Microcontroller	Must match value in Receive Slave Address register
9	Write	External Microcontroller	Always 0
10	ACK	Intel® ICH4	
11–18	Command code – 8 bits	External Microcontroller	Indicates which register is being accessed. See Table 5-97 .
19	ACK	ICH4	
20	Repeated Start	External Microcontroller	
21–27	Slave Address - 7 bits	External Microcontroller	Must match value in Receive Slave Address register
28	Read	External Microcontroller	Always 1
29	ACK	ICH4	
30–37	Data Byte	ICH4	Value depends on register being accessed. See Table 5-97 .
38	NOT ACK	External Microcontroller	
39	Stop	External Microcontroller	

Table 5-97. Data Values for Slave Read Registers (Sheet 1 of 2)

Register	Bits	Description
0	7:0	Reserved.
1	2:0	System Power State <ul style="list-style-type: none"> • 000 = S0 • 001 = S1 • 010 = Reserved • 011 = S3 • 100 = S4 • 101 = S5 • 110 = Reserved • 111 = Reserved
1	7:3	Reserved
2	3:0	Frequency Strap Register
2	7:4	Reserved
3	5:0	Watchdog Timer current value
3	7:6	Reserved
4	0	1 = The Intruder Detect (INTRD_DET) bit is set. This indicates that the system cover has probably been opened.
4	1	1 = BTI Temperature Event occurred. This bit will be set if the Intel® ICH4's THRM# input signal is active. Need to take after polarity control.
4	2	Boot-Status. This bit will be 1 when the processor does not fetch the first instruction.

Table 5-97. Data Values for Slave Read Registers (Sheet 2 of 2)

Register	Bits	Description
4	3	This bit will be set after the TCO timer times out a second time (Both TIMEOUT and SECOND_TO_STS bits set).
4	6:4	Reserved.
4	7	The bit will reflect the state of the GPI[11]/SMBALERT# signal, and will depend on the GP_INV[11] bit. It does not matter if the pin is configured as GPI[11] or SMBALERT#. <ul style="list-style-type: none"> If the GP_INV[11] bit is 1 then the value of register 4 bit 7 will equal the level of the GPI[11]/SMBALERT# pin (high = 1, low = 0). If the GP_INV[11] bit is 0 then the value of register 4 bit 7 will equal the inverse of the level of the GPI[11]/SMBALERT# pin (high = 1, low = 0).
5	0	Unprogrammed FWH bit. This bit will be 1 to indicate that the first BIOS fetch returned FFh, which indicates that the FWH is probably blank.
5	1	Reserved
5	2	CPU Power Failure Status: 1 if the CPUPWR_FLR bit in the GEN_PMCON_2 register is set.
5	7:3	Reserved
6	7:0	Contents of the Message 1 register. See Section 9.9.9 .
7	7:0	Contents of the Message 2 register. See Section 9.9.9 .
8	7:0	Contents of the WDSTATUS register. See Section 9.9.10 .
9–FFh	7:0	Reserved

5.18.7.2.1 Behavioral Notes

According to SMBus protocol, Read and Write messages always begin with a Start bit–Address–Write bit sequence. When the ICH4 detects that the address matches the value in the Receive Slave Address register, it will assume that the protocol is always followed and ignore the Write bit (bit 9) and signal an Acknowledge during bit 10 (See [Table 5-93](#) and [Table 5-96](#)). In other words, if a Start–Address–Read occurs (which is illegal for SMBus Read or Write protocol) and the address matches the ICH4’s Slave Address, the ICH4 will still grab the cycle.

Also according to SMBus protocol, a Read cycle contains a Repeated Start–Address–Read sequence beginning at bit 20 (See [Table 5-96](#)). Once again, if the Address matches the ICH4’s Receive Slave Address, it will assume that the protocol is followed, ignore bit 28, and proceed with the Slave Read cycle.

Note: An external microcontroller must not attempt to access the ICH4’s SMBus Slave logic until at least 1 second after both RTCRST# and RSMRST# are deasserted (high).

5.18.7.3 Format of Host Notify Command

The ICH4 tracks and responds to the standard Host Notify command as specified in the SMBus 2.0 specification. The host address for this command is fixed to 0001000b. If the ICH4 already has data for a previously-received host notify command which has not been serviced yet by the host software (as indicated by the HOST_NOTIFY_STS bit), then it will NACK following the host address byte of the protocol. This allows the host to communicate non-acceptance to the master and retain the host notify address and data values for the previous cycle until host software completely services the interrupt. [Table 5-98](#) shows the Host Notify format.

Note: Host software must always clear the HOST_NOTIFY_STS bit after completing any necessary reads of the address and data registers.

Table 5-98. Host Notify Format

Bit	Description	Driven by	Comment
1	Start	External Master	
2–8	SMB Host Address – 7 bits	External Master	Always 0001_000
9	Write	External Master	Always 0
10	ACK (or NACK)	Intel®ICH4	ICH4 NACKs if HOST_NOTIFY_STS is 1
11–17	Device Address – 7 bits	External Master	Indicates the address of the master; loaded into the Notify Device Address Register
18	Unused – Always 0	External Master	7-bit-only address; this bit is inserted to complete the byte
19	ACK	ICH4	
20–27	Data Byte Low – 8 bits	External Master	Loaded into the Notify Data Low Byte Register
28	ACK	ICH4	
29–36	Data Byte High – 8 bits	External Master	Loaded into the Notify Data High Byte Register
37	ACK	ICH4	
38	Stop	External Master	

5.19 AC '97 Controller Functional Description (Audio D31:F5, Modem D31:F6)

All references to AC '97 in this document refer to the *Audio Codec '97 Component Specification, Revision 2.3*. For further information on the operation of the AC-link protocol, see the AC '97 specification.

The ICH4 AC '97 controller features include:

- Independent PCI functions for audio and modem.
- Independent bus master logic for dual Microphone input, dual PCM Audio input (2-channel stereo per input), PCM audio output (2-, 4- or 6-channel audio), Modem input, Modem output and S/PDIF output.
- 20-bit sample resolution.
- Multiple sample rates up to 48 kHz.
- 16 GPIOs.
- Single modem line.
- Configure up to three codecs with three AC_SDIN pins.

Table 5-99 shows a detailed list of features supported by the ICH4 AC '97 digital controller.

Table 5-99. Features Supported by Intel® ICH4

Feature	Description
System Interface	<ul style="list-style-type: none"> • Isochronous low latency bus master memory interface • Scatter/gather support for word-aligned buffers in memory. (all mono or stereo 20-bit and 16-bit data types are supported, no 8-bit data types are supported). • Data buffer size in system memory from 3 to 65535 samples per input. • Data buffer size in system memory from 0 to 65535 samples per output. • Independent PCI audio and modem functions with configuration and IO spaces. • AC '97 codec registers are shadowed in system memory via driver. • AC '97 codec register accesses are serialized via semaphore bit in PCI IO space (new accesses are not allowed while a prior access is still in progress).
Power Management	<ul style="list-style-type: none"> • Power management via PCI Power Management
PCI Audio Function	<ul style="list-style-type: none"> • Read/write access to audio codec registers 00h–3Ah and vendor registers 5Ah–7Eh. • 20-bit stereo PCM output, up to 48 kHz (L,R, Center, Sub-woofer, L-rear and R-rear channels on slots 3,4,6,7,8,9,10,11). • 16-bit stereo PCM input, up to 48 kHz (L,R channels on slots 3,4). • 16-bit mono mic in w/ or w/o mono mix, up to 48 kHz (L,R channel, slots 3,4) (mono mix supports mono hardware AEC reference for speakerphone). • 16-bit mono PCM input, up to 48 kHz from dedicated mic ADC (slot 6) (supports speech recognition or stereo hardware AEC ref for speakerphone). • During cold reset, AC_RST# is held low until after POST and software deassertion of AC_RST# (supports passive PC_BEEP to speaker connection during POST).
PCI Modem function	<ul style="list-style-type: none"> • Read/write access to modem codec registers 3Ch–58h and vendor registers 5Ah–7Eh. • 16-bit mono modem line1 output and input, up to 48 kHz (slot 5). • Low latency GPIO[15:0] via hardwired update between slot 12 and PCI IO register. • Programmable PCI interrupt on modem GPIO input changes via slot 12 GPIO_INT. • SCI event generation on AC_SDIN[2:0] wake-up signals.
AC-link	<ul style="list-style-type: none"> • Supports AC '97 2.3 AC-link interface. • Variable sample rate output support via AC '97 SLOTRREQ protocol (slots 3,4,5,6,7,8,9,10,11). • Variable sample rate input support via monitoring of slot valid tag bits (slots 3,4,5,6) • 3.3 V digital operation meets AC '97 2.3 DC switching levels. • AC-link IO driver capability meets AC '97 2.3 triple codec specifications. • Codec register status reads must be returned with data in the next AC-link frame, per the AC '97 2.3 specification.
Multiple Codec	<ul style="list-style-type: none"> • Triple codec addressing: All AC '97 Audio codec register accesses are addressable to codec ID 00 (primary), codec ID 01 (secondary), or codec ID 10 (tertiary). • Modem codec addressing: All AC '97 Modem codec register accesses are addressable to codec ID 00 (primary) or codec ID 01 (secondary). • Triple codec receive capability via AC_SDIN[2:0] pins (AC_SDIN[2:0] frames are internally validated, synch'd, and OR'd depending on the Steer Enable bit status in the SDM register). • AC_SDIN mapping to DMA engine mapping capability allows for simultaneous input from three different audio codecs. <p>NOTES:</p> <ol style="list-style-type: none"> 1. Audio Codec IDs are remappable and not limited to 00,01,10. 2. Modem Codec IDs are remappable and limited to 00,01. 3. When using multiple codecs, the Modem Codec must be ID 01.

Note: Throughout this document, references to D31:F5 indicate that the audio function exists in PCI Device 31, Function 5. References to D31:F6 indicate that the modem function exists in PCI Device 31, Function 6.

Note: Throughout this document, references to tertiary, third, or triple codecs refer to the third codec in the system connected to the AC_SDIN[2] pin. The AC '97 2.3 specification refers to non-primary codecs as multiple secondary codecs. To avoid confusion and excess verbiage this datasheet refers to it as the third or tertiary codec.

Figure 5-20. Intel® ICH4 Based Audio Codec '97 Specification, Revision 2.3

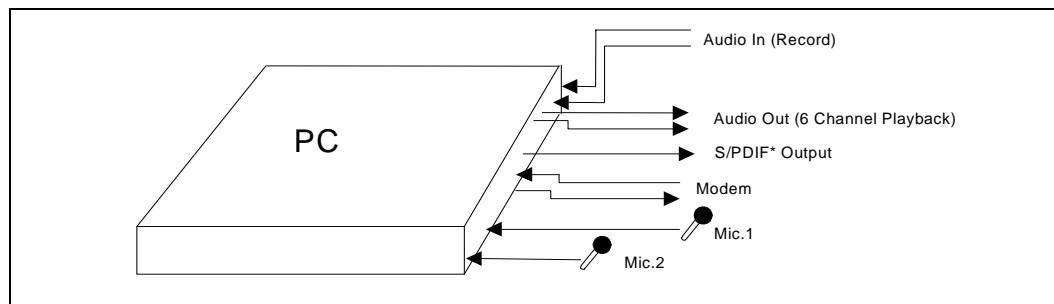

5.19.1 PCI Power Management

This Power Management section applies for all AC '97 controller functions. After a power management event is detected, the AC '97 controller will wake the host system. The sections below describe these events and the AC '97 controller power states.

Device Power States

The AC '97 controller supports D0 and D3 PCI Power Management states. Notes regarding the Intel ICH4 AC '97 controller implementation of the Device States:

1. The AC '97 controller hardware does not inherently consume any more power when it is in the D0 state than it does in D3 state. However, software can halt the DMA engine prior to entering these low power states such that the maximum power consumption is reduced.
2. In the D0 state, all implemented AC '97 controller features are enabled.
3. In D3 state, accesses to the AC '97 controller memory-mapped or I/O range result in master abort.
4. In D3 state, the AC '97 controller interrupt must never assert for any reason. The internal PME# signal is used to signal wake events, etc.
5. When the Device Power State field is written from D3_{HOT} to D0, an internal reset is generated. See [Section 14.1](#) for general rules on the effects of this reset.
6. AC '97 STS bit will be set only when the audio or modem resume events were detected and their respective PME enable bits were set.
7. GPIO Status change interrupt no longer has a direct path to AC '97 STS bit. This will cause a wake up event only if the modem controller was in D3
8. Resume events on AC_SDIN[2:0] will cause resume interrupt status bits to be set only if their respective controllers are not in D3.
9. Edge detect logic will prevent the interrupts from being asserted in case AC '97 controller is switched from D3 to D0 after a wake event.
10. Once the interrupt status bits are set, they will cause PIRQB# if their respective enable bits were set. One of the audio or the modem drivers will handle the interrupt.

5.19.2 AC-Link Overview

The ICH4 supports the AC '97 2.3 controller that communicates with companion codecs via a digital serial link called the AC-link. All digital audio/modem streams and command/status information is communicated over the AC-link.

The AC-link is a bi-directional, serial PCM digital stream. It handles multiple input and output data streams, as well as control register accesses, employing a time division multiplexed (TDM) scheme. The AC-link architecture provides for data transfer through individual frames transmitted in a serial fashion. Each frame is divided into 12 outgoing and 12 incoming data streams, or slots. The architecture of the ICH4 AC-link allows a maximum of three codecs to be connected.

Figure 5-21 shows a three codec topology of the AC-link for the ICH4.

Figure 5-21. AC '97 2.3 Controller-Codec Connection

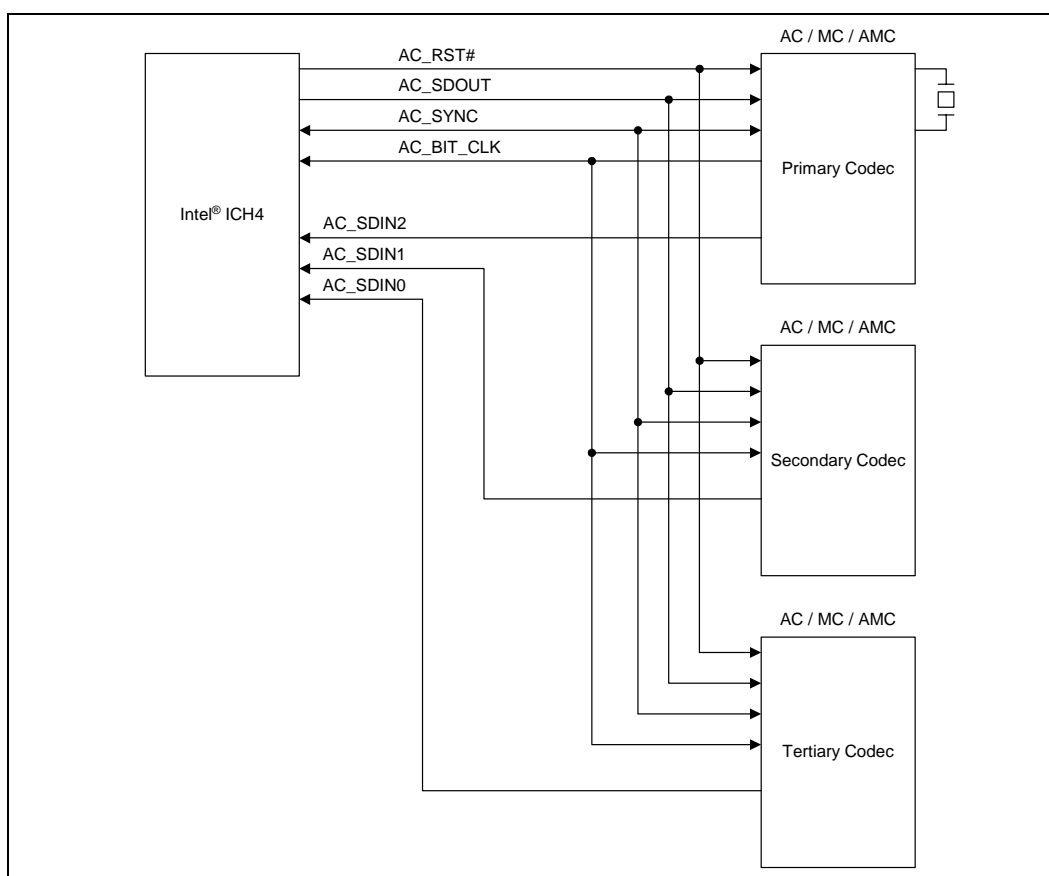

The AC-link consists of a five signal interface between the controller and codec. Table 5-100 indicates the AC-link signal pins on the ICH4 and their associated power wells.

Table 5-100. AC '97 Signals

Signal Name	Type	Power Well	Description
AC_RST#	Output	Resume	Master hardware reset
AC_SYNC	Output	Core	48 kHz fixed rate sample sync
AC_BIT_CLK	Input	Core	12.288 MHz Serial data clock
AC_SDOOUT	Output	Core	Serial output data
AC_SDIN 0	Input	Resume	Serial input data
AC_SDIN 1	Input	Resume	Serial input data
AC_SDIN 2	Input	Resume	Serial input data

NOTE: Power well voltage levels are 3.3 V.

ICH4 core well outputs may be used as strapping options for the ICH4, sampled during system reset. These signals may have weak pullups/pulldowns on them, however this will not interfere with link operation. ICH4 inputs integrate weak pulldowns to prevent floating traces when a secondary and/or tertiary codec is not attached. When the Shut Off bit in the control register is set, all buffers will be turned off and the pins will be held in a steady state, based on these pullups/pulldowns.

AC_BIT_CLK is fixed at 12.288 MHz and is sourced by the primary codec. It provides the necessary clocking to support the twelve 20-bit time slots. AC-link serial data is transitioned on each rising edge of AC_BIT_CLK. The receiver of AC-link data samples each serial bit on the falling edge of AC_BIT_CLK.

If AC_BIT_CLK makes no transitions for four consecutive PCI clocks, the ICH4 assumes the primary codec is not present or not working. It sets bit 28 of the Global Status Register (I/O offset 30h). All accesses to codec registers with this bit set will return data of FFh to prevent system hangs.

Synchronization of all AC-link data transactions is signaled by the AC '97 controller via the AC_SYNC signal, as shown in Figure 5-22. The primary codec drives the serial bit clock onto the AC-link, which the AC '97 controller then qualifies with the AC_SYNC signal to construct data frames. AC_SYNC, fixed at 48 kHz, is derived by dividing down AC_BIT_CLK. AC_SYNC remains high for a total duration of 16 AC_BIT_CLKs at the beginning of each frame. The portion of the frame where AC_SYNC is high is defined as the tag phase. The remainder of the frame where AC_SYNC is low is defined as the data phase. Each data bit is sampled on the falling edge of AC_BIT_CLK.

Figure 5-22. AC-Link Protocol

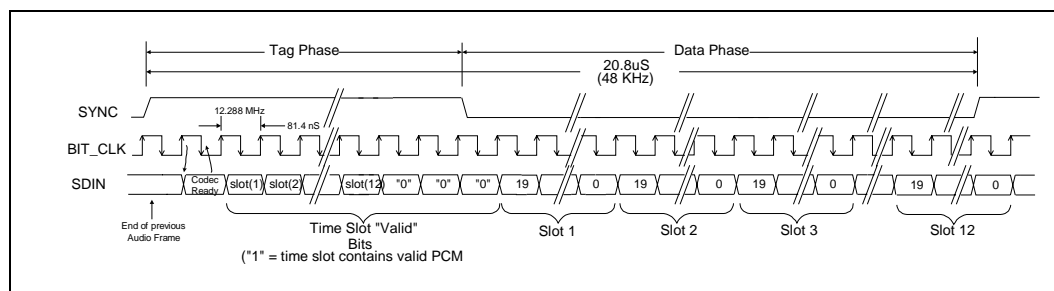

The ICH4 has three AC_SDIN pins allowing a single, dual, or triple codec configuration. When multiple codecs are connected, the primary, secondary, and tertiary codecs can be connected to any AC_SDIN line. The ICH4 does not distinguish between codecs on its AC_SDIN[2:0] pins; however, the registers do distinguish between AC_SDIN[0], AC_SDIN[1], and AC_SDIN[2] for wake events, etc. If using a Modem Codec it is recommended to connect it to AC_SDIN[1].

See your Platform Design Guide for a matrix of valid codec configurations. The ICH4 does not support optional test modes as outlined in the AC '97 specification.

5.19.2.1 AC-Link Output Frame (SDOUT)

A new output frame begins with a low-to-high transition of AC_SYNC. AC_SYNC is synchronous to the rising edge of BIT_CLK. On the immediately following falling edge of AC_BIT_CLK, the codec samples the assertion of AC_SYNC. This falling edge marks the time when both sides of AC-link are aware of the start of a new frame. On the next rising edge of AC_BIT_CLK, the ICH4 transitions AC_SDOOUT into the first bit position of slot 0, or the valid frame bit. Each new bit position is presented to the AC-link on a rising edge of AC_BIT_CLK, and subsequently sampled by the codec on the following falling edge of AC_BIT_CLK. This sequence ensures that data transitions and subsequent sample points for both incoming and outgoing data streams are time aligned.

The output frame data phase corresponds to the multiplexed bundles of all digital output data targeting codec DAC inputs and control registers. Each output frame supports up to twelve outgoing data time slots. The ICH4 generates 16 or 20 bits and stuffs remaining bits with zeros.

The output data stream is sent with the most significant bit first, and all invalid slots are stuffed with zeros. When mono audio sample streams are output from the ICH4, software must ensure both left and right sample stream time slots are filled with the same data.

5.19.2.2 Output Slot 0: Tag Phase

Slot 0 is considered the tag phase. The tag phase is a special 16-bit time slot wherein each bit conveys a valid tag for its corresponding time slot within the current frame. A one in a given bit position of slot 0 indicates that the corresponding time slot within the current frame has been assigned to a data stream and contains valid data. If a slot is tagged invalid with a zero in the corresponding bit position of slot 0, the ICH4 stuffs the corresponding slot with zeros during that slot's active time.

Within slot 0, the first bit is a valid frame bit (slot 0, bit 15) which flags the validity of the entire frame. If the valid frame bit is set to one, this indicates that the current frame contains at least one slot with valid data. When there is no transaction in progress, the ICH4 will deassert the frame valid bit. Note that after a write to slot 12, that slot will always stay valid, and therefore the frame valid bit will remain set.

The next 12 bit positions of slot 0 (bits [14:3]) indicate which of the corresponding twelve time slots contain valid data. Bits [1:0] of slot 0 are used as codec ID bits to distinguish between separate codecs on the link.

Using the valid bits in the tag phase allows data streams of differing sample rates to be transmitted across the link at its fixed 48 kHz frame rate. The codec can control the output sample rate of the ICH4 using the SLOTREQ bits as described in the AC '97 specification.

5.19.2.3 Output Slot 1: Command Address Port

The command port is used to control features and monitor status of AC '97 functions including, but not limited to, mixer settings and power management.

The control interface architecture supports up to 64, 16-bit read/write registers, addressable on even byte boundaries. Only the even registers (00h, 02h, etc.) are valid.

Output frame slot 1 communicates control register address, and write/read command information.

In the case of the multiple codec implementation, accesses to the codecs are differentiated by the driver using address offsets 00h–7Fh for the primary codec, address offsets 80h–FEh for the secondary codec, and address offsets 100h–17Fh for the tertiary codec. The differentiation on the link, however, is done via the codec ID bits. See [Section 5.19.2.23](#) for further details.

5.19.2.4 Output Slot 2: Command Data Port

The command data port is used to deliver 16-bit control register write data in the event that the current command port operation is a write cycle as indicated in slot 1, bit 19. If the current command port operation is a read then the entire slot time stuffed with zeros by the ICH4. Bits [19:4] contain the write data. Bits [3:0] are reserved and are stuffed with zeros.

5.19.2.5 Output Slot 3: PCM Playback Left Channel

Output frame slot 3 is the composite digital audio left playback stream. Typically, this slot is composed of standard PCM (.wav) output samples digitally mixed by the host processor. The ICH4 transmits sample streams of 16 bits or 20 bits and stuffs remaining bits with zeros.

Data in output slots 3 and 4 from the ICH4 should be duplicated by software if there is only a single channel out.

5.19.2.6 Output Slot 4: PCM Playback Right Channel

Output frame slot 4 is the composite digital audio right playback stream. Typically, this slot is composed of standard PCM (.wav) output samples digitally mixed by the host processor. The ICH4 transmits sample streams of 16 or 20 bits and stuffs remaining bits with zeros.

Data in output slots 3 and 4 from the ICH4 should be duplicated by software if there is only a single channel out.

5.19.2.7 Output Slot 5: Modem Codec

Output frame slot 5 contains modem DAC data. The modem DAC output supports 16-bit resolution. At boot time, if the modem codec is supported, the AC '97 controller driver determines the DAC resolution. During normal runtime operation the ICH4 stuffs trailing bit positions within this time slot with zeros.

5.19.2.8 Output Slot 6: PCM Playback Center Front Channel

When set up for 6-channel mode, this slot is used for the front center channel. The format is the same as Slots 3 and 4. If not set up for 6-channel mode, this channel will always be stuffed with zeros by ICH4.

5.19.2.9 Output Slots 7-8: PCM Playback Left and Right Rear Channels

When set up for 4 or 6 channel modes, slots 7 and 8 are used for the rear Left and Right channels. The format for these two channels are the same as Slots 3 and 4.

5.19.2.10 Output Slot 9: Playback Sub Woofer Channel

When set for 6-channel mode, this slot is used for the Sub Woofer. The format is the same as Slots 3. If not set up for 6-channel mode, this channel will always be stuffed with zeros by ICH4.

5.19.2.11 Output Slots 10-11: Reserved

Output frame slots 10–11 are reserved and are always stuffed with zeros by the ICH4 AC '97 controller.

5.19.2.12 Output Slot 12: I/O Control

The 16 bits of DAA and GPIO control (output) and status (input) have been directly assigned to bits on slot 12 in order to minimize latency of access to changing conditions.

The value of the bits in this slot are the values written to the GPIO control register at offset 54h and D4h (in the case of a secondary codec) in the modem codec I/O space. The following rules govern the usage of slot 12.

1. Slot 12 is marked invalid by default on coming out of AC-link reset, and will remain invalid until a register write to 54h/D4h.
2. A write to offset 54h/D4h in codec I/O space will cause the write data to be transmitted on slot 12 in the next frame, with slot 12 marked valid, and the address/data information to also be transmitted on slots 1 and 2.
3. After the first write to offset 54h/D4h, slot 12 remains valid for all following frames. The data transmitted on slot 12 is the data last written to offset 54h/D4h. Any subsequent write to the register will cause the new data to be sent out on the next frame.
4. Slot 12 will get invalidated after the following events: PCI reset, AC '97 cold reset, warm reset, and, hence, a wake from S3, S4, or S5. Slot 12 will remain invalid until the next write to offset 54h/D4h.

5.19.2.13 AC-Link Input Frame (SDIN)

There are three AC_SDIN lines on the ICH4 for use with up to three codecs. Each AC_SDIN pin can have a codec attached. The input frame data streams correspond to the multiplexed bundles of all digital input data targeting the AC '97 controller. As in the case for the output frame, each AC-link input frame consists of twelve time slots.

A new audio input frame begins with a low-to-high transition of AC_SYNC. AC_SYNC is synchronous to the rising edge of AC_BIT_CLK. On the immediately following falling edge of AC_BIT_CLK, the receiver samples the assertion of AC_SYNC. This falling edge marks the time when both sides of AC-link are aware of the start of a new audio frame. On the next rising edge of AC_BIT_CLK, the codec transitions AC_SDIN into the first bit position of slot 0 (codec ready bit). Each new bit position is presented to AC-link on a rising edge of AC_BIT_CLK, and subsequently sampled by the ICH4 on the following falling edge of AC_BIT_CLK. This sequence ensures that data transitions and subsequent sample points for both incoming and outgoing data streams are time aligned.

AC_SDIN data stream must follow the AC '97 specification and be MSB justified with all non-valid bit positions (for assigned and/or unassigned time slots) stuffed with zeros. AC_SDIN data is sampled by the ICH4 on the falling edge of AC_BIT_CLK.

5.19.2.14 Input Slot 0: Tag Phase

Input slot 0 consists of a codec ready bit (bit 15), and slot valid bits for each subsequent slot in the frame (bits [14:3]).

The codec ready bit within slot 0 (bit 15) indicates whether the codec on the AC-link is ready for register access (digital domain). If the codec ready bit in slot 0 is a zero, the codec is not ready for register access. When the AC-link codec ready bit is a 1, it indicates that the AC-link and codec control and status registers are in a fully operational state. The codec ready bits are visible through the Global Status register of the ICH4. Software must further probe the Powerdown Control/Status register in the codec to determine exactly which subsections, if any, are ready.

Bits [14:3] in slot 0 indicate which slots of the input stream to the ICH4 contain valid data, just as in the output frame. The remaining bits in this slot are stuffed with zeros.

5.19.2.15 Input Slot 1: Status Address Port / Slot Request Bits

The status port is used to monitor status of codec functions including, but not limited to, mixer settings and power management.

Slot 1 must echo the control register index, for historical reference, for the data to be returned in slot 2, assuming that slots 1 and 2 had been tagged valid by the codec in slot 0.

For variable sample rate output, the codec examines its sample rate control registers, the state of its FIFOs, and the incoming SDOOUT tag bits at the beginning of each audio output frame to determine which SLOTREQ bits to set active (low). SLOTREQ bits asserted during the current audio input frame signal which output slots require data from the controller in the next audio output frame. For fixed 48 kHz operation the SLOTREQ bits are always set active (low) and a sample is transferred each frame.

For variable sample rate input, the tag bit for each input slot indicates whether valid data is present or not.

Table 5-101. Input Slot 1 Bit Definitions

Bit	Description
19	Reserved (Set to zero)
18:12	Control Register Index (Stuffed with zeros if tagged invalid)
11	Slot 3 Request: PCM Left Channel ⁽¹⁾
10	Slot 4 Request: PCM Right Channel ⁽¹⁾
9	Slot 5 Request: Modem Line 1
8	Slot 6 Request: PCM Center Channel ⁽¹⁾
7	Slot 7 Request: PCM Left Surround ⁽¹⁾
6	Slot 8 Request: PCM Right Surround ⁽¹⁾
5	Slot 9 Request: PCM LFE Channel ⁽¹⁾
4:2	Slot Request 10–12: Not Implemented
1:0	Reserved (Stuffed with zeros)

NOTES:

1. Slot 3 Request and Slot 4 Request bits must be the same value (i.e., set or cleared in tandem). This is also true for the Slot 7 and Slot 8 Request bits, as well as the Slot 6 and Slot 9 Request bits.

As shown in [Table 5-101](#), slot 1 delivers codec control register read address and multiple sample rate slot request flags for all output slots of the controller. When a slot request bit is set by the codec, the controller will return data in that slot in the next output frame. Slot request bits for slots 3 and 4 are always set or cleared in tandem (i.e., both are set or cleared).

When set, the input slot 1 tag bit only pertains to Status Address Port data from a previous read. SLOTREQ bits are always valid independent of the slot 1 tag bit.

5.19.2.16 Input Slot 2: Status Data Port

The status data port receives 16-bit control register read data.

- Bit [19:4]: Control Register Read Data
- Bit [3:0]: Reserved.

5.19.2.17 Input Slot 3: PCM Record Left Channel

Input slot 3 is the left channel input of the codec. The ICH4 supports 16-bit sample resolution. Samples transmitted to the ICH4 must be in left/right channel order.

5.19.2.18 Input Slot 4: PCM Record Right Channel

Input slot 4 is the right channel input of the codec. The ICH4 supports 16-bit sample resolution. Samples transmitted to the ICH4 must be in left/right channel order.

5.19.2.19 Input Slot 5: Modem Line

Input slot 5 contains MSB justified modem data. The ICH4 supports 16-bit sample resolution.

5.19.2.20 Input Slot 6: Optional Dedicated Microphone Record Data

Input slot 6 is a third PCM system input channel available for dedicated use by a microphone. This input channel supplements a true stereo output which enables more precise echo cancellation algorithm for speakerphone applications. The ICH4 supports 16-bit resolution for slot 6 input.

5.19.2.21 Input Slots 7–11: Reserved

Input frame slots 7–11 are reserved for future use and should be stuffed with zeros by the codec, per the AC '97 specification.

5.19.2.22 Input Slot 12: I/O Status

The status of the GPIOs configured as inputs are to be returned on this slot in every frame. The data returned on the latest frame is accessible to software by reading the register at offset 54h/D4h in the codec I/O space. Only the 16 MSBs are used to return GPI status. In order for GPI events to cause an interrupt, both the 'sticky' and 'interrupt' bits must be set for that particular GPIO pin in regs 50h and 52h. Therefore, the interrupt will be signalled until it has been cleared by the controller, which can be much longer than one frame.

Reads from 54h/D4h will not be transmitted across the link in slot 1 and 2. The data from the most recent slot 12 is returned on reads from offset 54h/D4h.

5.19.2.23 Register Access

In the ICH4 implementation of the AC-link, up to three codecs can be connected to the AC_SDOOUT pin. The following mechanism is used to address the primary, secondary, and tertiary codecs individually.

The primary device uses bit 19 of slot 1 as the direction bit to specify read or write. Bits [18:12] of slot 1 are used for the register index. For I/O writes to the primary codec, the valid bits [14:13] for slots 1 and 2 must be set in slot 0, as shown in [Table 5-102](#). Slot 1 is used to transmit the register address, and slot 2 is used to transmit data. For I/O reads to the primary codec, only slot 1 should be valid since only an address is transmitted. For I/O reads only slot 1 valid bit is set, while for I/O writes both slots 1 and 2 valid bits are set.

The secondary and tertiary codec registers are accessed using slots 1 and 2 as described above, however the slot valid bits for slots 1 and 2 are marked invalid in slot 0 and the codec ID bits [1:0] (bit 0 and bit 1 of slot 0) is set to a non zero value. This allows the secondary or tertiary codec to monitor the slot valid bits of slots 1 and 2, and bits [1:0] of slot 0 to determine if the access is directed to the secondary or tertiary codec. If the register access is targeted to the secondary or tertiary codec, slot 1 and 2 will contain the address and data for the register access. Since slots 1 and 2 are marked invalid, the primary codec will ignore these accesses.

Table 5-102. Output Tag Slot 0

Bit	Primary Access Example	Secondary Access Example	Description
15	1	1	Frame Valid
14	1	0	Slot 1 Valid, Command Address bit (Primary codec only)
13	1	0	Slot 2 Valid, Command Data bit (Primary codec only)
12:3	X	X	Slot 3–12 Valid
2	0	0	Reserved
1:0	00	01	Codec ID (00 reserved for primary; 01 indicate secondary; 10 indicate tertiary)

When accessing the codec registers, only one I/O cycle can be pending across the AC-link at any time. The ICH4 implements write posting on I/O writes across the AC-link (i.e., writes across the link are indicated as complete before they are actually sent across the link). In order to prevent a second I/O write from occurring before the first one is complete, software must monitor the CAS bit in the Codec Access Semaphore register which indicates that a codec access is pending. Once the CAS bit is cleared, then another codec access (read or write) can go through. The exception to this being reads to offset 54h/D4h/154h (slot 12) which are returned immediately with the most recently received slot 12 data. Writes to offset 54h, D4h, and 154h (primary, secondary and tertiary codecs), get transmitted across the AC-link in slots 1 and 2 as a normal register access. Slot 12 is also updated immediately to reflect the data being written.

The controller will not issue back to back reads. It must get a response to the first read before issuing a second. In addition, codec reads and writes are only executed once across the link, and are not repeated.

5.19.3 AC-Link Low Power Mode

The AC-link signals can be placed in a low-power mode. When the AC '97 Powerdown Register (26h), is programmed to the appropriate value, both AC_BIT_CLK and AC_SDIN will be brought to, and held at a logic low voltage level.

Figure 5-23. AC-Link Powerdown Timing

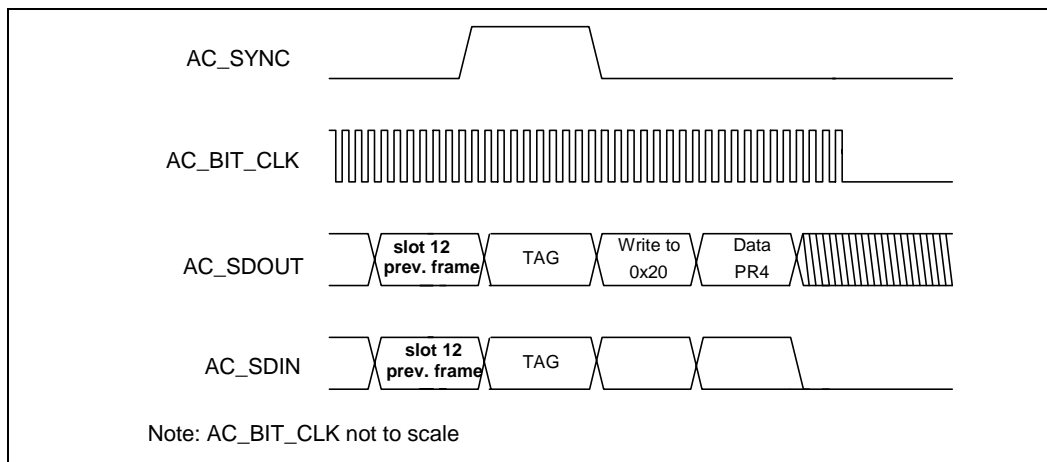

AC_BIT_CLK and AC_SDIN transition low immediately after a write to the Powerdown Register (26h) with PR4 enabled. When the AC '97 controller driver is at the point where it is ready to program the AC-link into its low-power mode, slots 1 and 2 are assumed to be the only valid stream in the audio output frame.

The AC '97 controller also drives AC_SYNC, and AC_SDOUT low after programming AC '97 to this low power, halted mode

Once the codec has been instructed to halt AC_BIT_CLK, a special wake up protocol must be used to bring the AC-link to the active mode since normal output and input frames cannot be communicated in the absence of AC_BIT_CLK. Once in a low-power mode, the ICH4 provides three methods for waking up the AC-link; external wake event, cold reset and warm reset.

Note: Before entering any low-power mode where the link interface to the codec is expected to be powered down while the rest of the system is awake, the software must set the “Shut Off” bit in the control register.

5.19.3.1 External Wake Event

Codecs can signal the controller to wake the AC-link, and wake the system using AC_SDIN.

Figure 5-24. SDIN Wake Signaling

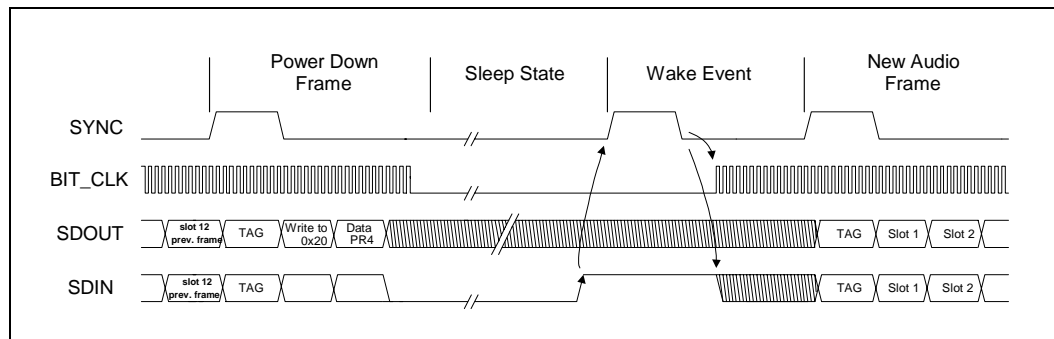

The minimum AC_SDIN wake up pulse width is 1 μ s. The rising edge of AC_SDIN[0], AC_SDIN[1] or AC_SDIN[2] causes the ICH4 to sequence through an AC-link warm reset and set the AC '97_STS bit in the GPE0_STS register to wake the system. The primary codec must wait to sample AC_SYNC high and low before restarting BIT_CLK as diagrammed in Figure 5-24. The codec that signaled the wake event must keep its AC_SDIN high until it has sampled AC_SYNC having gone high, and then low.

The AC-link protocol provides for a cold reset and a warm reset. The type of reset used depends on the system's current power down state. Unless a cold or register reset (a write to the Reset register in the codec) is performed, wherein the AC '97 codec registers are initialized to their default values, registers are required to keep state during all power down modes.

Once powered down, activation of the AC-link via re-assertion of the AC_SYNC signal must not occur for a minimum of 4 audio frame times following the frame in which the power down was triggered. When AC-link powers up, it indicates readiness via the codec ready bit.

5.19.4 AC '97 Cold Reset

A cold reset is achieved by asserting AC_RST# for 1 μ s. By driving AC_RST# low, BIT_CLK, and SDOUT will be activated and all codec registers will be initialized to their default power on reset values. AC_RST# is an asynchronous AC '97 input to the codec.

5.19.5 AC '97 Warm Reset

A warm reset will re-activate the AC-link without altering the current codec register values. A warm reset is signaled by driving AC_SYNC high for a minimum of 1 μ s in the absence of BIT_CLK.

Within normal frames, AC_SYNC is a synchronous AC '97 input to the codec. However, in the absence of AC_BIT_CLK, AC_SYNC is treated as an asynchronous input to the codec used in the generation of a warm reset.

The codec must not respond with the activation of AC_BIT_CLK until AC_SYNC has been sampled low again by the codec. This will prevent the false detection of a new frame.

Note: On receipt of wake up signalling from the codec, the digital controller will issue an interrupt if enabled. Software will then have to issue a warm or cold reset to the codec by setting the appropriate bit in the Global Control Register.

5.19.6 System Reset

Table 5-103 indicates the states of the link during various system reset and sleep conditions.

Table 5-103. AC-link State during PCIRST#

Signal	Power Plane	I/O	During PCIRST#	After PCIRST#	S1	S3	S4/S5
AC_RST#	Resume ³	Output	Low	Low	Cold Reset bit (Hi)	Low	Low
AC_SDOOUT	Core ¹	Output	Low	Running	Low	Low	Low
AC_SYNC	Core	Output	Low	Running	Low	Low	Low
AC_BIT_CLK	Core	Input	Driven by codec	Running	Low ^{2,4}	Low ^{2,4}	Low ^{2,4}
AC_SDIN[2:0]	Resume	Input	Driven by codec	Running	Low ^{2,4}	Low ^{2,4}	Low ^{2,4}

NOTES:

1. ICH4 core well outputs are used as strapping options for the ICH4, sampled during system reset. These signals may have weak pullups/pulldowns on them. The ICH4 outputs will be driven to the appropriate level prior to AC_RST# being deasserted, preventing a codec from entering test mode. Straps are tied to the core well to prevent leakage during a suspend state.
2. The pull-down resistors on these signals are only enabled when the AC-Link Shut Off bit in the AC '97 Global Control Register is set to 1. All other times, the pull-down resistor is disabled.
3. AC_RST# will be held low during S3–S5. It cannot be programmed high during a suspend state.
4. AC_BIT_CLK and AC_SDIN[2:0] are driven low by the codecs during normal states. If the codec is powered during suspend states it will hold these signals low. However, if the codec is not present, or not powered in suspend, external pull-down resistors are required.

The transition of AC_RST# to the deasserted state will only occur under driver control. In the S1 sleep state, the state of the AC_RST# signal is controlled by the AC '97 Cold Reset# bit (bit 1) in the Global Control register. AC_RST# will be asserted (low) by the ICH4 under the following conditions:

- RSMRST# (system reset, including the a reset of the resume well and PCIRST#)
- Mechanical power up (causes PCIRST#)
- Write to CF9h hard reset (causes PCIRST#)
- Transition to S3/S4/S5 sleep states (causes PCIRST#)
- Write to AC '97 Cold Reset# bit in the Global Control Register.

Hardware will never deassert AC_RST# (i.e., never deasserts the Cold Reset# bit) automatically. Only software can deassert the Cold Reset# bit, and hence the AC_RST# signal. This bit, while it resides in the core well, will remain cleared upon return from S3/S4/S5 sleep states. The AC_RST# pin will remain actively driven from the resume well as indicated.

5.19.7 Hardware Assist to Determine AC_SDIN Used Per Codec

Software first performs a read to one of the audio codecs. The read request goes out on AC_SDOOUT. Since under our micro-architecture only one read can be performed at a time on the link, eventually the read data will come back in on one of the AC_SDIN[2:0] lines.

The codec will do this by indicating that status data is valid in its TAG, then echo the read address in slot 1 followed by the read data in slot 2.

The new function of the ICH4 hardware is to notice which AC_SDIN line contains the read return data, and to set new bits in the new register indicating which AC_SDIN line the register read data returned on. If it returned on AC_SDIN0, bits [1:0] contain the value 00. If it returned on AC_SDIN1, the bits contain the value 01, etc.

ICH4 hardware can set these bits every time register read data is returned from a function 5 read. No special command is necessary to cause the bits to be set. The new driver/BIOS software will read the bits from this register when it cares to, and can ignore it otherwise. When software is attempting to establish the codec-to-AC_SDIN mapping, it will single feed the read request and not pipeline to ensure it gets the right mapping, we cannot ensure the serialization of the access.

5.19.8 Software Mapping of AC_SDIN to DMA Engine

Once software has performed the register read to determine codec-to-AC_SDIN mapping, it will then either set bits 5:4 or 7:6 in the SDATA_IN MAP register to map this codec to the DMA engine. After it maps the audio codecs, it will set the “SE” (steer enable) bit, which now lets the hardware know to no longer OR the AC_SDIN lines, and to use the mappings in the register to steer the appropriate AC_SDIN line to the correct DMA engines.

This page is intentionally left blank

Register and Memory Mapping

6

The ICH4 contains registers that are located in the processor's I/O space and memory space and sets of PCI configuration registers that are located in PCI configuration space. This chapter describes the ICH4 I/O and memory maps at the register-set level. Register access is also described. Register-level address maps and Individual register bit descriptions are provided in the following chapters. The following notations and definitions are used in the register/instruction description chapters.

RO	Read Only. In some cases, If a register is read only, writes to this register location have no effect. However, in other cases, two separate registers are located at the same location where a read accesses one of the registers and a write accesses the other register. See the I/O and memory map tables for details.
WO	Write Only. In some cases, If a register is write only, reads to this register location have no effect. However, in other cases, two separate registers are located at the same location where a read accesses one of the registers and a write accesses the other register. See the I/O and memory map tables for details.
R/W	Read/Write. A register with this attribute can be read and written.
R/WC	Read/Write Clear. A register bit with this attribute can be read and written. However, a write of 1 clears (sets to 0) the corresponding bit and a write of 0 has no effect.
R/WO	Read/Write-Once. A register bit with this attribute can be written only once after power up. After the first write, the bit becomes read only.
Default	When ICH4 is reset, it sets its registers to predetermined default states. The default state represents the minimum functionality feature set required to successfully bring up the system. Hence, it does not represent the optimal system configuration. It is the responsibility of the system initialization software to determine configuration, operating parameters, and optional system features that are applicable, and to program the ICH4 registers accordingly.
Bold	Register bits that are highlighted in bold text indicate that the bit is implemented in the ICH4. Register bits that are not implemented or are hardwired will remain in plain text.

6.1 PCI Devices and Functions

The ICH4 incorporates a variety of PCI functions as shown in [Table 6-1](#). These functions are divided into four logical devices (B0:D30, B0:D31, B0:D29 and B1:D8). D30 is the hub interface-to-PCI bridge, D31 contains the PCI-to-LPC Bridge, IDE controller, SMBus controller and the AC '97 Audio and Modem controller functions and D29 contains the three USB UHCI controllers and one USB EHCI controller. B1:D8 is the integrated LAN controller.

Note: From a software perspective, the integrated LAN controller resides on the ICH4's external PCI bus (See [Section 5.1.2](#)). This is typically Bus 1, but may be assigned a different number depending upon system configuration.

If for some reason, the particular system platform does not want to support any one of Device 31's Functions 1–6, Device 29's functions, or Device 8, they can individually be disabled. The integrated LAN controller will be disabled if no Platform LAN Connect component is detected (See [Section 5.2.1.3](#)). When a function is disabled, it does not appear at all to the software. A disabled function will not respond to any register reads or writes. This is intended to prevent software from thinking that a function is present (and reporting it to the end-user).

Table 6-1. PCI Devices and Functions

Bus:Device:Function	Function Description
Bus 0:Device 30:Function 0	Hub Interface to PCI Bridge
Bus 0:Device 31:Function 0	PCI to LPC Bridge ¹
Bus 0:Device 31:Function 1	IDE Controller
Bus 0:Device 31:Function 3	SMBus Controller
Bus 0:Device 31:Function 5	AC '97 Audio Controller
Bus 0:Device 31:Function 6	AC '97 Modem Controller
Bus 0:Device 29:Function 0	USB UHCI Controller #1
Bus 0:Device 29:Function 1	USB UHCI Controller #2
Bus 0:Device 29:Function 2	USB UHCI Controller #3
Bus 0:Device 29:Function 7	USB 2.0 EHCI Controller
Bus n:Device 8:Function 0	LAN Controller

NOTES:

1. The PCI to LPC bridge contains registers that control LPC, power management, system management, GPIO, processor interface, RTC, interrupts, timers, DMA.

6.2 PCI Configuration Map

Each PCI function on the ICH4 has a set of PCI configuration registers. The register address map tables for these register sets are included at the beginning of the chapter for the particular function. Refer to [Table A-1](#) for a complete list of all PCI Configuration Registers.

Configuration Space registers are accessed through configuration cycles on the PCI bus by the Host bridge using configuration mechanism #1 detailed in the *PCI Local Bus Specification, Revision 2.2*.

Some of the PCI registers contain reserved bits. Software must deal correctly with fields that are reserved. On reads, software must use appropriate masks to extract the defined bits and not rely on reserved bits being any particular value. On writes, software must ensure that the values of reserved bit positions are preserved. That is, the values of reserved bit positions must first be read, merged with the new values for other bit positions and then written back. Note the software does not need to perform read, merge, write operation for the configuration address register.

In addition to reserved bits within a register, the configuration space contains reserved locations. Software should not write to reserved PCI configuration locations in the device-specific region (above address offset 3Fh).

6.3 I/O Map

The I/O map is divided into Fixed and Variable address ranges. Fixed ranges cannot be moved, but in some cases can be disabled. Variable ranges can be moved and can also be disabled.

6.3.1 Fixed I/O Address Ranges

[Table 6-2](#) shows the Fixed I/O decode ranges from the CPU perspective. Note that for each I/O range, there may be separate behavior for reads and writes. The hub interface cycles that go to target ranges that are marked as “Reserved” will not be decoded by the ICH4, and will be passed to PCI. If a PCI master targets one of the fixed I/O target ranges, it will be positively decoded by the ICH4 in Medium speed.

Refer to [Table A-2](#) for a complete list of all fixed I/O registers.

Address ranges that are not listed or marked “Reserved” are NOT decoded by the ICH4 (unless assigned to one of the variable ranges).

Table 6-2. Fixed I/O Ranges Decoded by Intel® ICH4 (Sheet 1 of 2)

I/O Address	Read Target	Write Target	Internal Unit
00h–08h	DMA Controller	DMA Controller	DMA
09h–0Eh	RESERVED	DMA Controller	DMA
0Fh	DMA Controller	DMA Controller	DMA
10h–18h	DMA Controller	DMA Controller	DMA
19h–1Eh	RESERVED	DMA Controller	DMA
1Fh	DMA Controller	DMA Controller	DMA
20h–21h	Interrupt Controller	Interrupt Controller	Interrupt
24h–25h	Interrupt Controller	Interrupt Controller	Interrupt
28h–29h	Interrupt Controller	Interrupt Controller	Interrupt
2Ch–2Dh	Interrupt Controller	Interrupt Controller	Interrupt
2E–2F	LPC SIO	LPC SIO	Forwarded to LPC
30h–31h	Interrupt Controller	Interrupt Controller	Interrupt
34h–35h	Interrupt Controller	Interrupt Controller	Interrupt
38h–39h	Interrupt Controller	Interrupt Controller	Interrupt
3Ch–3Dh	Interrupt Controller	Interrupt Controller	Interrupt
40h–42h	Timer/Counter	Timer/Counter	PIT (8254)
43h	RESERVED	Timer/Counter	PIT
4E–4F	LPC SIO	LPC SIO	Forwarded to LPC
50h–52h	Timer/Counter	Timer/Counter	PIT
53h	RESERVED	Timer/Counter	PIT
60h	Microcontroller	Microcontroller	Forwarded to LPC
61h	NMI Controller	NMI Controller	CPU I/F
62h	Microcontroller	Microcontroller	Forwarded to LPC
63h	NMI Controller	NMI Controller	CPU I/F
64h	Microcontroller	Microcontroller	Forwarded to LPC
65h	NMI Controller	NMI Controller	CPU I/F
66h	Microcontroller	Microcontroller	Forwarded to LPC
67h	NMI Controller	NMI Controller	CPU I/F
70h	RESERVED	NMI and RTC Controller	RTC
71h	RTC Controller	RTC Controller	RTC
72h	RTC Controller	NMI and RTC Controller	RTC
73h	RTC Controller	RTC Controller	RTC
74h	RTC Controller	NMI and RTC Controller	RTC
75h	RTC Controller	RTC Controller	RTC
76h	RTC Controller	NMI and RTC Controller	RTC
77h	RTC Controller	RTC Controller	RTC
80h	DMA Controller	DMA Controller and LPC or PCI	DMA

Table 6-2. Fixed I/O Ranges Decoded by Intel® ICH4 (Sheet 2 of 2)

I/O Address	Read Target	Write Target	Internal Unit
81h–83h	DMA Controller	DMA Controller	DMA
84h–86h	DMA Controller	DMA Controller and LPC or PCI	DMA
87h	DMA Controller	DMA Controller	DMA
88h	DMA Controller	DMA Controller and LPC or PCI	DMA
89h–8Bh	DMA Controller	DMA Controller	DMA
8Ch–8Eh	DMA Controller	DMA Controller and LPC or PCI	DMA
08Fh	DMA Controller	DMA Controller	DMA
90h–91h	DMA Controller	DMA Controller	DMA
92h	Reset Generator	Reset Generator	CPU I/F
93h–9Fh	DMA Controller	DMA Controller	DMA
A0h–A1h	Interrupt Controller	Interrupt Controller	Interrupt
A4h–A5h	Interrupt Controller	Interrupt Controller	Interrupt
A8h–A9h	Interrupt Controller	Interrupt Controller	Interrupt
ACh–ADh	Interrupt Controller	Interrupt Controller	Interrupt
B0h–B1h	Interrupt Controller	Interrupt Controller	Interrupt
B2h–B3h	Power Management	Power Management	Power Management
B4h–B5h	Interrupt Controller	Interrupt Controller	Interrupt
B8h–B9h	Interrupt Controller	Interrupt Controller	Interrupt
BCh–BDh	Interrupt Controller	Interrupt Controller	Interrupt
C0h–D1h	DMA Controller	DMA Controller	DMA
D2h–DDh	RESERVED	DMA Controller	DMA
DEh–DFh	DMA Controller	DMA Controller	DMA
F0h	See Note 3	FERR#/IGNNE# / Interrupt Controller	CPU I/F
170h–177h	IDE Controller ²	IDE Controller ²	Forwarded to IDE
1F0h–1F7h	IDE Controller ¹	IDE Controller ¹	Forwarded to IDE
376h	IDE Controller ²	IDE Controller ²	Forwarded to IDE
3F6h	IDE Controller ¹	IDE Controller ¹	Forwarded IDE
4D0h–4D1h	Interrupt Controller	Interrupt Controller	Interrupt
CF9h	Reset Generator	Reset Generator	CPU I/F

NOTES:

1. Only if IDE Standard I/O space is enabled for Primary Channel and the IDE controller is in legacy mode. Otherwise, the target is PCI.
2. Only if IDE Standard I/O space is enabled for Secondary Channel and the IDE controller is in legacy mode. Otherwise, the target is PCI.
3. If POS_DEC_EN bit is enabled, reads from F0h will not be decoded by the ICH4. If POS_DEC_EN is not enabled, reads from F0h will forward to LPC.

6.3.2 Variable I/O Decode Ranges

Table 6-3 shows the Variable I/O Decode Ranges. They are set using Base Address Registers (BARs) or other configuration bits in the various PCI configuration spaces. The PNP software (PCI or ACPI) can use their configuration mechanisms to set and adjust these values.

When a cycle is detected on the hub interface, the ICH4 will positively decode the cycle. If the response is on the behalf of an LPC device, ICH4 will forward the cycle to the LPC I/F.

Refer to Table A-3 for a complete list of all variable I/O registers.

Warning: The Variable I/O Ranges should not be set to conflict with the Fixed I/O Ranges. Unpredictable results if the configuration software allows conflicts to occur. The ICH4 does not perform any checks for conflicts.

Table 6-3. Variable I/O Decode Ranges

Range Name	Mappable	Size (Bytes)	Target
ACPI	Anywhere in 64-KB I/O Space	64	Power Management
IDE Bus Master	Anywhere in 64-KB I/O Space	16	IDE Unit
USB UHCI Controller #1	Anywhere in 64-KB I/O Space	32	USB Unit 1
SMBus	Anywhere in 64-KB I/O Space	32	SMB Unit
AC '97 Audio Mixer	Anywhere in 64-KB I/O Space	256	AC '97 Unit
AC '97 Bus Master	Anywhere in 64-KB I/O Space	64	AC '97 Unit
AC '97 Modem Mixer	Anywhere in 64-KB I/O Space	256	AC '97 Unit
TCO	96 Bytes above ACPI Base	32	TCO Unit
GPIO	Anywhere in 64-KB I/O Space	64	GPIO Unit
Parallel Port	3 ranges in 64-KB I/O Space	8	LPC Peripheral
Serial Port 1	8 Ranges in 64-KB I/O Space	8	LPC Peripheral
Serial Port 2	8 Ranges in 64-KB I/O Space	8	LPC Peripheral
Floppy Disk Controller	2 Ranges in 64-KB I/O Space	8	LPC Peripheral
MIDI	4 Ranges in 64-KB I/O Space	2	LPC Peripheral
MSS	4 Ranges in 64-KB I/O Space	8	LPC Peripheral
SoundBlaster	2 Ranges in 64-KB I/O Space	32	LPC Peripheral
LAN	Anywhere in 64-KB I/O Space	64	LAN Unit
USB UHCI Controller #2	Anywhere in 64-KB I/O Space	32	USB Unit 2
USB UHCI Controller #3	Anywhere in 64-KB I/O Space	32	USB Unit 3
LPC Generic 1	Anywhere in 64-KB I/O Space	128	LPC Peripheral
LPC Generic 2	Anywhere in 64-KB I/O Space	16	LPC Peripheral
Monitors 4:7	Anywhere in 64-KB I/O Space	16	LPC Peripheral or Trap on PCI
Native IDE Primary Command	Anywhere in 64-KB I/O Space	8	IDE Unit
Native IDE Primary Control	Anywhere in 64-KB I/O Space	4	IDE Unit
Native IDE Secondary Command	Anywhere in 64-KB I/O Space	8	IDE Unit
Native IDE Secondary Control	Anywhere in 64-KB I/O Space	4	IDE Unit

6.4 Memory Map

Table 6-4 shows (from the processor perspective) the memory ranges that the ICH4 will decode. Cycles that arrive from the hub interface that are not directed to any of the internal memory targets that decode directly from hub interface will be driven out on PCI. The ICH4 may then claim the cycle for it to be forwarded to LPC or claimed by the internal APIC. If subtractive decode is enabled, the cycle can be forwarded to LPC.

PCI cycles generated by an external PCI master will be positively decoded unless it falls in the PCI-PCI bridge forwarding range (those addresses are reserved for PCI peer-to-peer traffic). If the cycle is not in the I/O APIC or LPC ranges, it will be forwarded up the hub interface to the Host controller. PCI masters can not access the memory ranges for functions that decode directly from Hub Interface.

Table 6-4. Memory Decode Ranges from Processor Perspective (Sheet 1 of 2)

Memory Range	Target	Dependency/Comments
0000 0000–000D FFFFh 0010 0000h–TOM (Top of Memory)	Main Memory	TOM registers in Host controller
000E 0000–000F FFFFh	FWH	Bit 7 in FWH Decode Enable Register is set
FEC0 0000–FEC0 0100h	I/O APIC inside ICH4	
FFC0 0000–FFC7 FFFFh FF80 0000–FF87 FFFFh	FWH	Bit 0 in FWH Decode Enable Register
FFC8 0000–FFCF FFFFh FF88 0000–FF8F FFFFh	FWH	Bit 1 in FWH Decode Enable Register
FFD0 0000–FFD7 FFFFh FF90 0000–FF97 FFFFh	FWH	Bit 2 in FWH Decode Enable Register is set
FFD8 0000–FFDF FFFFh FF98 0000–FF9F FFFFh	FWH	Bit 3 in FWH Decode Enable Register is set
FFE0 0000–FFE7 FFFFh FFA0 0000–FFA7 FFFFh	FWH	Bit 4 in FWH Decode Enable Register is set
FFE8 0000–FFE7 FFFFh FFA8 0000–FFAF FFFFh	FWH	Bit 5 in FWH Decode Enable Register is set
FFF0 0000–FFF7 FFFFh FFB0 0000–FFB7 FFFFh	FWH	Bit 6 in FWH Decode Enable Register is set.
FFF8 0000–FFFF FFFFh FFB8 0000–FFBF FFFFh	FWH	Always enabled. The top two 64 KB blocks of this range can be swapped, as described in Section 7.4.1 .
FF70 0000–FF7F FFFFh FF30 0000–FF3F FFFFh	FWH	Bit 3 in FWH Decode Enable 2 Register is set
FF60 0000–FF6F FFFFh FF20 0000–FF2F FFFFh	FWH	Bit 2 in FWH Decode Enable 2 Register is set
FF50 0000–FF5F FFFFh FF10 0000–FF1F FFFFh	FWH	Bit 1 in FWH Decode Enable 2 Register is set
FF40 0000–FF4F FFFFh FF00 0000–FF0F FFFFh	FWH	Bit 0 in FWH Decode Enable 2 Register is set
4 KB anywhere in 4 GB range	Integrated LAN Controller	Enable via BAR in Device 29:Function 0 (Integrated LAN Controller)

Table 6-4. Memory Decode Ranges from Processor Perspective (Sheet 2 of 2)

Memory Range	Target	Dependency/Comments
1 KB anywhere in 4 GB range	IDE Expansion ²	Enable via standard PCI mechanism and bits in IDE I/O Configuration Register (Device 31, Function 1)
1 KB anywhere in 4 GB range	USB EHCI Controller ^{1,2}	Enable via standard PCI mechanism (Device 29, Function 7)
All other	PCI	None

NOTES:

1. These ranges are decoded directly from the hub interface. The memory cycles will not be seen on PCI.
2. Software must not attempt locks to memory mapped I/O ranges for USB EHCI and IDE Expansion. If attempted, the lock is not honored, which means potential deadlock conditions may occur.

6.4.1 Boot-Block Update Scheme

The ICH4 supports a “top-block swap” mode that has the ICH4 swap the top block in the FWH (the boot block) with another location. This allows for safe update of the Boot Block (even if a power failure occurs). When the “TOP_SWAP” Enable bit is set, the ICH4 will invert A16 for cycles targeting FWH BIOS space. When this bit is 0, the ICH4 will not invert A16. This bit is automatically set to 0 by RTCRST#, but not by PCIRST#.

The scheme is based on the concept that the top block is reserved as the “boot” block, and the block immediately below the top block is reserved for doing boot-block updates.

The algorithm is:

1. Software copies the top block to the block immediately below the top
2. Software checks that the copied block is correct. This could be done by performing a checksum calculation.
3. Software sets the TOP_SWAP bit. This will invert A16 for cycles going to the FWH. CPU access to FFFF_0000 through FFFF_FFFF will be directed to FFFE_0000 through FFFE_FFFF in the FWH, and processor accesses to FFFE_0000 through FFFE_FFFF will be directed to FFFF_0000 through FFFF_FFFF.
4. Software erases the top block
5. Software writes the new top block
6. Software checks the new top block
7. Software clears the TOP_SWAP bit

If a power failure occurs at any point after step 3, the system will be able to boot from the copy of the boot block that is stored in the block below the top. This is because the TOP_SWAP bit is backed in the RTC well.

Note: The top-block swap mode may be forced by an external strapping option (See [Section 2.20.1](#)). When top-block swap mode is forced in this manner, the TOP_SWAP bit cannot be cleared by software. A re-boot with the strap removed will be required to exit a forced top-block swap mode.

Note: Top-block swap mode only affects accesses to the FWH BIOS space, not feature space.

Note: The top-block swap mode has no effect on accesses below FFFE_0000.

LAN Controller Registers (B1:D8:F0) 7

The ICH4 integrated LAN controller appears to reside at PCI Device 8, Function 0 on the secondary side of the ICH4's virtual PCI-to-PCI Bridge (See [Section 5.1.2](#)). This is typically Bus 1, but may be assigned a different number depending upon system configuration. The LAN controller acts as both a master and a slave on the PCI bus. As a master, the LAN controller interacts with the system main memory to access data for transmission or deposit received data. As a slave, some of the LAN controller's control structures are accessed by the host processor to read or write information to the on-chip registers. The processor also provides the LAN controller with the necessary commands and pointers that allow it to process receive and transmit data.

7.1 PCI Configuration Registers (B1:D8:F0)

Note: Registers that are not shown should be treated as Reserved (See [Section 6.2](#) for details).

Table 7-1. LAN Controller PCI Configuration Register Address Map (LAN Controller—B1:D8:F0)

Offset	Mnemonic	Register Name	Default	Type
00–01h	VID	Vendor ID	8086h	RO
02–03h	DID	Device ID	103Ah	RO
04–05h	PCICMD	PCI Device Command Register	0000h	R/W, RO
06–07h	PCISTS	PCI Device Status Register	0290h	R/WC, RO
08h	REVID	Revision ID	See Note	RO
0Ah	SCC	Sub Class Code	00h	RO
0Bh	BCC	Base Class Code	02h	RO
0Dh	PMLT	PCI Master Latency Timer	00h	R/W
0Eh	HEADTYP	Header Type	00h	RO
10–13h	CSR_MEM_BASE	CSR Memory-Mapped Base Address	0008h	R/W, RO
14–17h	CSR_IO_BASE	CSR I/O-Mapped Base Address	0001h	R/W, RO
2C–2Dh	SVID	Subsystem Vendor ID	0000h	RO
2E–2Fh	SID	Subsystem ID	0000h	RO
34h	CAP_PTR	Capabilities Pointer	DCh	RO
3Ch	INT_LN	Interrupt Line	00h	R/W
3D	INT_PN	Interrupt Pin	01h	RO
3E	MIN_GNT	Minimum Grant	08h	RO
3F	MAX_LAT	Maximum Latency	38h	RO
DCh	CAP_ID	Capability ID	01h	RO
DDh	NXT_PTR	Next Item Pointer	00h	RO
DE–DFh	PM_CAP	Power Management Capabilities	FE21h	RO
E0–E1h	PMCSR	Power Management Control/Status	0000h	R/WC, R/W, RO
E3	PCIDATA	PCI Power Management Data	00h	RO

NOTE: Refer to the ICH4 specification update for the value of the Revision ID Register.

7.1.1 VID—Vendor ID Register (LAN Controller—B1:D8:F0)

Offset Address: 00–01h Attribute: RO
Default Value: 8086h Size: 16 bits

Bit	Description
15:0	Vendor Identification Value — RO. This is a 16-bit value assigned to Intel.

7.1.2 DID—Device ID Register (LAN Controller—B1:D8:F0)

Offset Address: 02–03h Attribute: RO
Default Value: 103Ah Size: 16 bits

Bit	Description
15:0	Device Identification Value — RO. This is a 16-bit value assigned to the Intel® ICH4 integrated LAN controller. <ol style="list-style-type: none">1. If the EEPROM is not present (or not properly programmed), reads to the Device ID return the default value of 103Ah2. If the EEPROM is present (and properly programmed) and if the value of Word 23h is not 0000f or FFFFh, the Device ID is loaded from the EEPROM, Word 23h after the hardware reset. (See Section 7.1.14 for details)

7.1.3 PCICMD—PCI Command Register (LAN Controller—B1:D8:F0)

Offset Address: 04–05h
 Default Value: 0000h

Attribute: R/W, RO
 Size: 16 bits

Bit	Description
15:10	Reserved
9	Fast Back to Back Enable (FBE) — RO. Hardwired to 0. The integrated LAN controller will not run fast back-to-back PCI cycles.
8	SERR# Enable (SERR_EN) — R/W. 0 = Disable. 1 = Enable. Allow SERR# to be asserted.
7	Wait Cycle Control (WCC) — RO. Hardwired to 0. Not implemented.
6	Parity Error Response (PER) — R/W 0 = The LAN controller will ignore PCI parity errors. 1 = The integrated LAN controller will take normal action when a PCI parity error is detected and will enable generation of parity on the hub interface.
5	VGA Palette Snoop (VPS) — RO. Hardwired to 0. Not Implemented.
4	Memory Write and Invalidate Enable (MWIE) — R/W. 0 = Disable. The LAN controller will not use the Memory Write and Invalidate command. 1 = Enable.
3	Special Cycle Enable (SCE) — RO. Hardwired to 0. The LAN controller ignores special cycles.
2	Bus Master Enable (BME) — R/W. 0 = Disable. 1 = Enable. The Intel® ICH4's integrated may function as a PCI bus master.
1	Memory Space Enable (MSE) — R/W. 0 = Disable. 1 = Enable. The ICH4's integrated LAN controller will respond to the memory space accesses.
0	I/O Space Enable (IOSE) — R/W. 0 = Disable. 1 = Enable. The ICH4's integrated LAN controller will respond to the I/O space accesses.

7.1.4 PCISTS—PCI Status Register (LAN Controller—B1:D8:F0)

Offset Address: 06–07h Attribute: R/WC, RO
 Default Value: 0290h Size: 16 bits

Bit	Description
15	Detected Parity Error (DPE) — R/WC. 0 = This bit is cleared by writing a 1 to the bit location. 1 = The Intel® ICH4's integrated LAN controller has detected a parity error on the PCI bus (will be set even if Parity Error Response is disabled in the PCI Command register).
14	Signaled System Error (SSE) — R/WC. 0 = This bit is cleared by writing a 1 to the bit location. 1 = The ICH4's integrated LAN controller has asserted SERR#. (SERR# can be routed to cause NMI, SMI# or interrupt).
13	Master Abort Status (MAS) — R/WC. 0 = This bit is cleared by writing a 1 to the bit location. 1 = The ICH4's integrated LAN controller (as a PCI master) has generated a master abort.
12	Received Target Abort (RTA) — R/WC. 0 = This bit is cleared by writing a 1 to the bit location. 1 = The ICH4's integrated LAN controller (as a PCI master) has received a target abort.
11	Signaled Target Abort (STA) — RO. Hardwired to 0. The device will never signal Target Abort.
10:9	DEVSEL# Timing Status (DEV_STS) —RO. 01h = Medium timing.
8	Data Parity Error Detected (DPED) — R/WC. 0 = This bit is cleared by writing a 1 to the bit location. 1 = All of the following three conditions have been met: 1. The LAN controller is acting as bus master 2. The LAN controller has asserted PERR# (for reads) or detected PERR# asserted (for writes) 3. The Parity Error Response bit in the LAN controller's PCI Command Register is set.
7	Fast Back to Back Capable (FB2BC) — RO. Hardwired to 1. The device can accept fast back-to-back transactions.
6	User Definable Features (UDF) — RO. Hardwired to 0. Not implemented.
5	66 MHz Capable (66MHZ_CAP) — RO. Hardwired to 0. The device does not support 66 MHz PCI.
4	Capabilities List (CAP_LIST) — RO. 0 = The EEPROM indicates that the integrated LAN controller does not support PCI Power Management. 1 = The EEPROM indicates that the integrated LAN controller supports PCI Power Management.
3:0	Reserved

7.1.9 PMLT—PCI Master Latency Timer Register (LAN Controller—B1:D8:F0)

Offset Address: 0Dh Attribute: R/W
 Default Value: 00h Size: 8 bits

Bit	Description
7:3	Master Latency Timer Count (MLTC) — R/W. Defines the number of PCI clock cycles that the integrated LAN controller may own the bus while acting as bus master.
2:0	Reserved

7.1.10 HEADTYP—Header Type Register (LAN Controller—B1:D8:F0)

Offset Address: 0Eh Attribute: RO
 Default Value: 00h Size: 8 bits

Bit	Description
7	Multi-Function Device — RO. Hardwired to 0 to indicate a single function device.
6:0	Header Type — RO. This 7-bit field identifies the header layout of the configuration space as an Ethernet controller.

7.1.11 CSR_MEM_BASE CSR — Memory-Mapped Base Address Register (LAN Controller—B1:D8:F0)

Offset Address: 10–13h Attribute: R/W, RO
 Default Value: 0000 0008h Size: 32 bits

Note: The ICH4's integrated LAN controller requires one BAR for memory mapping. Software determines which BAR (memory or I/O) is used to access the Lan controller's CSR registers.

Bit	Description
31:12	Base Address — R/W. Upper 20 bits of the base address provides 4 KB of memory-Mapped space for the LAN controller's Control/Status Registers.
11:4	Reserved
3	Prefetchable — RO. Hardwired to 0 to indicate that this is not a pre-fetchable memory-Mapped address range.
2:1	Type — RO. Hardwired to 00b to indicate the memory-Mapped address range may be located anywhere in 32-bit address space.
0	Memory Space Indicator — RO. Hardwired to 0 to indicate that this base address maps to memory space.

7.1.12 CSR_IO_BASE — CSR I/O-Mapped Base Address Register (LAN Controller—B1:D8:F0)

Offset Address: 14–17h Attribute: R/W, RO
 Default Value: 0000 0001h Size: 32 bits

Note: The ICH4’s integrated LAN controller requires one BAR for memory mapping. Software determines which BAR (memory or I/O) is used to access the Lan controller’s CSR registers.

Bit	Description
31:16	Reserved
15:6	Base Address — R/W. Provides 64 bytes of I/O-Mapped address space for the LAN controller’s Control/Status Registers.
5:1	Reserved
0	I/O Space Indicator — RO. Hardwired to 1 to indicate that this base address maps to I/O space.

7.1.13 SVID — Subsystem Vendor ID (LAN Controller—B1:D8:F0)

Offset Address: 2C–2D Attribute: RO
 Default Value: 0000h Size: 16 bits

Bit	Description
15:0	Subsystem Vendor ID (SVID) — RO. (see Section 7.1.14 for details)

7.1.14 SID — Subsystem ID (LAN Controller—B1:D8:F0)

Offset Address: 2E–2Fh Attribute: RO
 Default Value: 0000h Size: 16 bits

Bit	Description
15:0	Subsystem ID (SID) — RO.

Note: The ICH4’s integrated LAN controller provides support for configurable Subsystem ID and Subsystem Vendor ID fields. After reset, the LAN controller automatically reads addresses Ah through Ch, and 23h of the EEPROM. The LAN controller checks bits 15:13 in the EEPROM word Ah, and functions according to [Table 7-2](#).

Table 7-2. Configuration of Subsystem ID and Subsystem Vendor ID via EEPROM

Bits 15:14	Bit 13	Device ID	Vendor ID	Revision ID	Subsystem ID	Subsystem Vendor ID
11b, 10b, 00b	X	103Ah	8086h	Note 1	0000h	0000h
01b	0b	Word 23h	8086h	Note 1	Word Bh	Word Ch
01b	1b	Word 23h	Word Ch	REVID + Word Ah, bits 10:8	Word Bh	Word Ch

NOTE:

1. Refer to the ICH4 specification update for the value of the Revision ID Register.
2. The Device ID is loaded from Word 23h only if the value of Word 23h is not 0000h or FFFFh

7.1.15 CAP_PTR — Capabilities Pointer (LAN Controller—B1:D8:F0)

Offset Address: 34h Attribute: RO
Default Value: DCh Size: 8 bits

Bit	Description
7:0	Capabilities Pointer (CAP_PTR) — RO. Hardwired to DCh; indicates the offset within configuration space for the location of the Power Management registers.

7.1.16 INT_LN — Interrupt Line Register (LAN Controller—B1:D8:F0)

Offset Address: 3Ch Attribute: R/W
Default Value: 00h Size: 8 bits

Bit	Description
7:0	Interrupt Line (INT_LN) — R/W. Identifies the system interrupt line to which the LAN controller's PCI interrupt request pin (as defined in the Interrupt Pin Register) is routed.

7.1.17 INT_PN — Interrupt Pin Register (LAN Controller—B1:D8:F0)

Offset Address: 3Dh Attribute: RO
Default Value: 01h Size: 8 bits

Bit	Description
7:0	Interrupt Pin (INT_PN) — RO. Hardwired to 01h to indicate that the LAN controller's interrupt request is connected to PIRQA#. However, in the Intel® ICH4 implementation, when the LAN controller interrupt is generated PIRQ[E]# will go active, not PIRQ[A]#. Note that if the PIRQ[E]# signal is used as a GPIO, the external visibility will be lost (though PIRQ[E]# will still go active internally).

7.1.18 MIN_GNT — Minimum Grant Register (LAN Controller—B1:D8:F0)

Offset Address: 3Eh Attribute: RO
Default Value: 08h Size: 8 bits

Bit	Description
7:0	Minimum Grant (MIN_GNT) — RO. This field indicates the amount of time (in increments of 0.25 μ s) that the LAN controller needs to retain ownership of the PCI bus when it initiates a transaction.

7.1.22 PM_CAP — Power Management Capabilities (LAN Controller—B1:D8:F0)

Offset Address: DE–DFh Attribute: RO
 Default Value: FE21h Size: 16 bits

Bit	Description
15:11	PME Support — RO. Hardwired to 11111b. This 5-bit field indicates the power states in which the LAN controller may assert PME#. The LAN controller supports wake-up in all power states.
10	D2 Support — RO. Hardwired to 1 to indicate that the LAN controller supports the D2 power state.
9	D1 Support — RO. Hardwired to 1 to indicate that the LAN controller supports the D1 power state.
8:6	Auxiliary Current — RO. Hardwired to 000b to indicate that the LAN controller implements the Data registers. The auxiliary power consumption is the same as the current consumption reported in the D3 state in the Data register.
5	Device Specific Initialization (DSI) — RO. Hardwired to 1 to indicate that special initialization of this function is required (beyond the standard PCI configuration header) before the generic class device driver is able to use it. DSI is required for the LAN controller after D3-to-D0 reset.
4	Reserved
3	PME Clock — RO. Hardwired to 0 to indicate that the LAN controller does not require a clock to generate a power management event.
2:0	Version — RO. Hardwired to 010b to indicate that the LAN controller complies with of the <i>PCI Power Management Specification, Revision 1.1</i> .

7.1.23 PMCSR — Power Management Control/Status Register (LAN Controller—B1:D8:F0)

Offset Address: E0–E1h Attribute: R/WC, R/W, RO
 Default Value: 0000h Size: 16 bits

Bit	Description
15	PME Status — R/WC. 0 = Software clears this bit by writing a 1 to the bit location. This also deasserts the PME# signal and clears the PME status bit in the Power Management Driver Register. When the PME# signal is enabled, the PME# signal reflects the state of the PME status bit. 1 = Set upon occurrence of a wake-up event, independent of the state of the PME Enable bit.
14:13	Data Scale — RO. This field indicates the data register scaling factor. It equals 10b for registers zero through eight and 00b for registers nine through fifteen, as selected by the “Data Select” field.
12:9	Data Select — R/W. This field is used to select which data is reported through the Data register and Data Scale field.
8	PME Enable — R/W. This bit enables the Intel® ICH4’s integrated LAN controller to assert PME#. 0 = The device will not assert PME#. 1 = Enable PME# assertion when PME Status is set.
7:5	Reserved
4	Dynamic Data — RO. Hardwired to 0 to indicate that the device does not support the ability to monitor the power consumption dynamically.
3:2	Reserved

Bit	Description
1:0	Power State — R/W. This 2-bit field is used to determine the current power state of the integrated LAN controller, and to put it into a new power state. The definition of the field values is as follows: 00 = D0 01 = D1 10 = D2 11 = D3

7.1.24 PCIDATA — PCI Power Management Data Register (LAN Controller—B1:D8:F0)

Offset Address:	E3h	Attribute:	RO
Default Value:	00h	Size:	8 bits

Bit	Description
7:0	State dependent power consumption and heat dissipation data.

Note: The data register is an 8-bit read only register that provides a mechanism for the ICH4's integrated LAN controller to report state dependent maximum power consumption and heat dissipation. The value reported in this register depends on the value written to the Data Select field in the PMCSR register. The power measurements defined in this register have a dynamic range of 0 W to 2.55 W with 0.01 W resolution, scaled according to the Data Scale field in the PMCSR. The structure of the Data Register is given in Table 7-3.

Table 7-3. Data Register Structure

Data Select	Data Scale	Data Reported
0	2	D0 Power Consumption
1	2	D1 Power Consumption
2	2	D2 Power Consumption
3	2	D3 Power Consumption
4	2	D0 Power Dissipated
5	2	D1 Power Dissipated
6	2	D2 Power Dissipated
7	2	D3 Power Dissipated
8	2	Common Function Power Dissipated
9–15	0	Reserved

7.2 LAN Control / Status Registers (CSR)

Table 7-4. Intel® ICH4 Integrated LAN Controller CSR Space

Offset	Register Name	Default	Type
01h–00h	SCB Status Word	0000h	R/WC
03h–02h	SCB Command Word	0000h	R/W
07h–04h	SCB General Pointer	0000 0000h	R/W
0Bh–08h	PORT	0000 0000h	R/W-Special
0Dh–0Ch	Reserved	—	—
0Eh	EEPROM Control Register	00h	R/W, RO, WO
0Fh	Reserved	—	—
13h–10h	MDI Control Register	0000 0000h	R/W-Special
17h–14h	Receive DMA Byte Count	0000 0000h	RO
18h	Early Receive Interrupt	00h	R/W
1A–19h	Flow Control Register	0000h	R/W
1Bh	PMDR	00h	R/WC
1Ch	General Control	00	R/W
1Dh	General Status	N/A	RO
1Eh–3Ch	Reserved	—	—

7.2.1 System Control Block Status Word Register

Offset Address: 00–01h Attribute: R/WC, RO
 Default Value: 0000h Size: 16 bits

The ICH4's integrated LAN controller places the status of its Command and Receive units and interrupt indications in this register for the processor to read.

Bit	Description
15	Command Unit (CU) Executed (CX) — R/WC. 0 = Software acknowledges the interrupt and clears this bit by writing a 1 to the bit position. 1 = Interrupt signaled because the CU has completed executing a command with its interrupt bit set.
14	Frame Received (FR) — R/WC. 0 = Software acknowledges the interrupt and clears this bit by writing a 1 to the bit position. 1 = Interrupt signaled because the Receive Unit (RU) has finished receiving a frame.
13	CU Not Active (CNA) — R/WC. 0 = Software acknowledges the interrupt and clears this bit by writing a 1 to the bit position. 1 = The Command Unit left the Active state or entered the Idle state. There are 2 distinct states of the CU. When configured to generate CNA interrupt, the interrupt will be activated when the CU leaves the Active state and enters either the Idle or the Suspended state. When configured to generate CI interrupt, an interrupt will be generated only when the CU enters the Idle state.

Bit	Description																
12	<p>Receive Not Ready (RNR) — R/WC.</p> <p>0 = Software acknowledges the interrupt and clears this bit by writing a 1 to the bit position.</p> <p>1 = Interrupt signaled because the Receive Unit left the Ready state. This may be caused by an RU Abort command, a no resources situation, or set suspend bit due to a filled Receive Frame Descriptor.</p>																
11	<p>Management Data Interrupt (MDI) — R/WC.</p> <p>0 = Software acknowledges the interrupt and clears this bit by writing a 1 to the bit position.</p> <p>1 = Set when a Management Data Interface read or write cycle has completed. The management data interrupt is enabled through the interrupt enable bit (bit 29 in the Management Data Interface Control register in the CSR).</p>																
10	<p>Software Interrupt (SWI) — R/WC.</p> <p>0 = Software acknowledges the interrupt and clears this bit by writing a 1 to the bit position.</p> <p>1 = Set when software generates an interrupt.</p>																
9	<p>Early Receive (ER) — R/WC.</p> <p>0 = Software acknowledges the interrupt and clears this bit by writing a 1 to the bit position.</p> <p>1 = Indicates the occurrence of an Early Receive Interrupt.</p>																
8	<p>Flow Control Pause (FCP) — R/WC.</p> <p>0 = Software acknowledges the interrupt and clears this bit by writing a 1 to the bit position.</p> <p>1 = Indicates Flow Control Pause interrupt.</p>																
7:6	<p>Command Unit Status (CUS) — RO.</p> <p>00 = Idle 01 = Suspended 10 = LPQ (Low Priority Queue) active 11 = HPQ (High Priority Queue) active</p>																
5:2	<p>Receive Unit Status (RUS) —RO.</p> <table border="0"> <tr> <td>0000 = Idle</td> <td>1000 = Reserved</td> </tr> <tr> <td>0001 = Suspended</td> <td>1001 = Suspended with no more RBDs</td> </tr> <tr> <td>0010 = No Resources</td> <td>1010 = No resources due to no more RBDs</td> </tr> <tr> <td>0011 = Reserved</td> <td>1011 = Reserved</td> </tr> <tr> <td>0100 = Ready</td> <td>1100 = Ready with no RBDs present</td> </tr> <tr> <td>0101 = Reserved</td> <td>1101 = Reserved</td> </tr> <tr> <td>0110 = Reserved</td> <td>1110 = Reserved</td> </tr> <tr> <td>0111 = Reserved</td> <td>1111 = Reserved</td> </tr> </table>	0000 = Idle	1000 = Reserved	0001 = Suspended	1001 = Suspended with no more RBDs	0010 = No Resources	1010 = No resources due to no more RBDs	0011 = Reserved	1011 = Reserved	0100 = Ready	1100 = Ready with no RBDs present	0101 = Reserved	1101 = Reserved	0110 = Reserved	1110 = Reserved	0111 = Reserved	1111 = Reserved
0000 = Idle	1000 = Reserved																
0001 = Suspended	1001 = Suspended with no more RBDs																
0010 = No Resources	1010 = No resources due to no more RBDs																
0011 = Reserved	1011 = Reserved																
0100 = Ready	1100 = Ready with no RBDs present																
0101 = Reserved	1101 = Reserved																
0110 = Reserved	1110 = Reserved																
0111 = Reserved	1111 = Reserved																
1:0	Reserved																

7.2.2 System Control Block Command Word Register

Offset Address: 02–03h Attribute: R/W
 Default Value: 0000h Size: 16 bits

The processor places commands for the Command and Receive units in this register. Interrupts are also acknowledged in this register.

Bit	Description
15	CX Mask — R/W. 0 = Interrupt not masked. 1 = Disable the generation of a CX interrupt.
14	FR Mask — R/W. 0 = Interrupt not masked. 1 = Disable the generation of an FR interrupt.
13	CNA Mask — R/W. 0 = Interrupt not masked. 1 = Disable the generation of a CNA interrupt.
12	RNR Mask — R/W. 0 = Interrupt not masked. 1 = Disable the generation of an RNR interrupt.
11	ER Mask — R/W. 0 = Interrupt not masked. 1 = Disable the generation of an ER interrupt.
10	FCP Mask — R/W. 0 = Interrupt not masked. 1 = Disable the generation of an FCP interrupt.
9	Software Generated Interrupt (SI) — WO. 0 = No Effect. 1 = Setting this bit causes the LAN controller to generate an interrupt.
8	Interrupt Mask (IM) — R/W. This bit enables or disables the LAN controller's assertion of the INTA# signal. This bit has higher precedence than the Specific Interrupt Mask bits and the SI bit. 0 = Enable the assertion of INTA#. 1 = Disable the assertion of INTA#.

Bit	Description
7:4	<p>Command Unit Command (CUC) — R/W. Valid values are listed below. All other values are Reserved.</p> <p>0000 = NOP: Does not affect the current state of the unit.</p> <p>0001 = CU Start: Start execution of the first command on the CBL. A pointer to the first CB of the CBL should be placed in the SCB General Pointer before issuing this command. The CU Start command should only be issued when the CU is in the Idle or Suspended states (never when the CU is in the active state), and all of the previously issued Command Blocks have been processed and completed by the CU. Sometimes it is only possible to determine that all Command Blocks are completed by checking that the Complete bit is set in all previously issued Command Blocks.</p> <p>0010 = CU Resume: Resume operation of the Command unit by executing the next command. This command will be ignored if the CU is idle.</p> <p>0011 = CU HPQ Start: Start execution of the first command on the high priority CBL. A pointer to the first CB of the HPQ CBL should be placed in the SCB General Pointer before issuing this command.</p> <p>0100 = Load Dump Counters Address: Tells the device where to write dump data when using the Dump Statistical Counters or Dump and Reset Statistical Counters commands. This command must be executed at least once before any usage of the Dump Statistical Counters or Dump and Reset Statistical Counters commands. The address of the dump area must be placed in the General Pointer register.</p> <p>0101 = Dump Statistical Counters: Tells the device to dump its statistical counters to the area designated by the Load Dump Counters Address command.</p> <p>0110 = Load CU Base: The device's internal CU Base Register is loaded with the value in the CSB General Pointer.</p> <p>0111 = Dump and Reset Statistical Counters: Tells the device to dump its statistical counters to the area designated by the Load Dump Counters Address command, and then to clear these counters.</p> <p>1010 = CU Static Resume: Resume operation of the Command unit by executing the next command. This command will be ignored if the CU is idle. This command should be used only when the CU is in the Suspended state and has no pending CU Resume commands.</p> <p>1011 = CU HPQ Resume: Resume execution of the first command on the HPQ CBL. this command will be ignored if the HPQ was never started.</p>
3	Reserved
2:0	<p>Receive Unit Command (RUC) — R/W. Valid values are:</p> <p>000 = NOP: Does not affect the current state of the unit.</p> <p>001 = RU Start: Enables the receive unit. The pointer to the RFA must be placed in the SCB General Pointer before using this command. The device pre-fetches the first RFD and the first RBD (if in flexible mode) in preparation to receive incoming frames that pass its address filtering.</p> <p>010 = RU Resume: Resume frame reception (only when in suspended state).</p> <p>011 = RCV DMA Redirect: Resume the RCV DMA when configured to "Direct DMA Mode." The buffers are indicated by an RBD chain which is pointed to by an offset stored in the General Pointer Register (this offset will be added to the RU Base).</p> <p>100 = RU Abort: Abort RU receive operation immediately.</p> <p>101 = Load Header Data Size (HDS): This value defines the size of the Header portion of the RFDs or Receive buffers. The HDS value is defined by the lower 14 bits of the SCB General Pointer, so bits 31:15 should always be set to zeros when using this command. Once a Load HDS command is issued, the device expects only to find Header RFDs, or be used in "RCV Direct DMA mode" until it is reset. Note that the value of HDS should be an even, non-zero number.</p> <p>110 = Load RU Base: The device's internal RU Base Register is loaded with the value in the SCB General Pointer.</p> <p>111 = RBD Resume: Resume frame reception into the RFA. This command should only be used when the RU is already in the "No Resources due to no RBDs" state or the "Suspended with no more RBDs" state.</p>

7.2.3 System Control Block General Pointer Register

Offset Address: 04–07h Attribute: R/W
 Default Value: 0000 0000h Size: 32 bits

Bit	Description
15:0	SCB General Pointer — R/W. The SCB General Pointer register is programmed by software to point to various data structures in main memory depending on the current SCB Command word.

7.2.4 PORT Register

Offset Address: 08–0Bh Attribute: R/W (special)
 Default Value: 0000 0000h Size: 32 bits

The PORT interface allows the processor to reset the ICH4's internal LAN controller, or perform an internal self test. The PORT DWORD may be written as a 32-bit entity, two 16-bit entities, or four 8-bit entities. The LAN controller will only accept the command after the high byte (offset 0Bh) is written; therefore, the high byte must be written last.

Bit	Description
31:4	Pointer Field — R/W (special). A 16-byte aligned address must be written to this field when issuing a Self-Test command to the PORT interface. The results of the Self Test will be written to the address specified by this field.
3:0	<p>PORT Function Selection — R/W (special). Valid values are listed below. All other values are Reserved.</p> <p>0000 = PORT Software Reset: Completely resets the LAN controller (all CSR and PCI registers). This command should not be used when the device is active. If a PORT Software Reset is desired, software should do a Selective Reset (described below), wait for the PORT register to be cleared (completion of the Selective Reset), and then issue the PORT Software Reset command. Software should wait approximately 10 μs after issuing this command before attempting to access the LAN controller's registers again.</p> <p>0001 = Self Test: The Self-Test begins by issuing an internal Selective Reset followed by a general internal self-test of the LAN controller. The results of the self-test are written to memory at the address specified in the Pointer field of this register. The format of the self-test result is shown in Table 7-5. After completing the self-test and writing the results to memory, the LAN controller will execute a full internal reset and will re-initialize to the default configuration. Self-Test does not generate an interrupt of similar indicator to the host processor upon completion.</p> <p>0010 = Selective Reset: Sets the CU and RU to the Idle state, but otherwise maintains the current configuration parameters (RU and CU Base, HDSSize, Error Counters, Configure information and Individual/Multicast Addresses are preserved). Software should wait approximately 10 μs after issuing this command before attempting to access the LAN controller's registers again.</p>

Table 7-5. Self-Test Results Format

Bit	Description
31:13	Reserved
12	General Self-Test Result — R/W (special). 0 = Pass 1 = Fail
11:6	Reserved
5	Diagnose Result — R/W (special). This bit provides the result of an internal diagnostic test of the Serial Subsystem. 0 = Pass 1 = Fail
4	Reserved
3	Register Result — R/W (special). This bit provides the result of a test of the internal Parallel Subsystem registers. 0 = Pass 1 = Fail
2	ROM Content Result — R/W (special). This bit provides the result of a test of the internal microcode ROM. 0 = Pass 1 = Fail
1:0	Reserved

7.2.5 EEPROM Control Register

Offset Address: 0Eh Attribute: RO, R/W, WO
Default Value: 00h Size: 8 bits

The EEPROM Control Register is a 16-bit field that enables a read from and a write to the external EEPROM.

Bit	Description
7:4	Reserved
3	EEPROM Serial Data Out (EEDO) — RO. Note that this bit represents "Data Out" from the perspective of the EEPROM device. This bit contains the value read from the EEPROM when performing read operations.
2	EEPROM Serial Data In (EEDI) — WO. Note that this bit represents "Data In" from the perspective of the EEPROM device. The value of this bit is written to the EEPROM when performing write operations.
1	EEPROM Chip Select (EECS) — R/W. 0 = Drives the Intel® ICH4's EE_CS signal low, to disable the EEPROM. This bit must be set to 0 for a minimum of 1 μ s between consecutive instruction cycles. 1 = Drives the ICH4's EE_CS signal high, to enable the EEPROM.
0	EEPROM Serial Clock (EESK) — R/W. Toggling this bit, clocks data into or out of the EEPROM. Software must ensure that this bit is toggled at a rate that meets the EEPROM component's minimum clock frequency specification. 0 = Drives the ICH4's EE_SHCLK signal low. 1 = Drives the ICH4's EE_SHCLK signal high.

7.2.6 Management Data Interface (MDI) Control Register

Offset Address:	10–13h	Attribute:	R/W (special)
Default Value:	0000 0000h	Size:	32 bits

The Management Data Interface (MDI) Control register is a 32-bit field and is used to read and write bits from the LAN Connect component. This register may be written as a 32-bit entity, two 16-bit entities, or four 8-bit entities. The LAN controller will only accept the command after the high byte (offset 13h) is written, therefore the high byte must be written last.

Bit	Description
31:30	These bits are reserved and should be set to 00b.
29	Interrupt Enable — R/W. 0 = Disable. 1 = Enables the LAN controller to assert an interrupt to indicate the end of an MDI cycle.
28	Ready — R/W. 0 = Expected to be reset by software at the same time the command is written. 1 = Set by the LAN controller at the end of an MDI transaction.
27:26	Opcode — R/W. These bits define the opcode: 00 = Reserved 01 = MDI write 10 = MDI read 11 = Reserved
25:21	LAN Connect Address — R/W. This field of bits contains the LAN Connect address.
20:16	LAN Connect Register Address — R/W. This field of bits contains the LAN Connect Register Address.
15:0	Data — R/W. In a write command, software places the data bits in this field, and the LAN controller transfers the data to the external LAN Connect component. During a read command, the LAN controller reads these bits serially from the LAN Connect, and software reads the data from this location.

7.2.9 Flow Control Register

Offset Address: 19–1Ah Attribute: RO, R/W (special)
 Default Value: h Size: 16 bits

Bit	Description																					
15:13	Reserved																					
12	<p>FC Paused Low — RO.</p> <p>0 = Cleared when the FC timer reaches zero, or a Pause frame is received.</p> <p>1 = Set when the LAN controller receives a Pause Low command with a value greater than zero.</p>																					
11	<p>FC Paused — RO.</p> <p>0 = Cleared when the FC timer reaches zero.</p> <p>1 = Set when the LAN controller receives a Pause command regardless of its cause (FIFO reaching Flow Control Threshold, fetching a Receive Frame Descriptor with its Flow Control Pause bit set, or software writing a 1 to the Xoff bit).</p>																					
10	<p>FC Full — RO.</p> <p>0 = Cleared when the FC timer reaches zero.</p> <p>1 = Set when the LAN controller sends a Pause command with a value greater than zero.</p>																					
9	<p>Xoff — R/W (special). This bit should only be used if the LAN controller is configured to operate with IEEE frame-based flow control.</p> <p>0 = This bit can only be cleared by writing a 1 to the Xon bit (bit 8 in this register).</p> <p>1 = Writing a 1 to this bit forces the Xoff request to 1 and causes the LAN controller to behave as if the FIFO extender is full. This bit will also be set to 1 when an Xoff request due to an “RFD Xoff” bit.</p>																					
8	<p>Xon — WO. This bit should only be used if the LAN controller is configured to operate with IEEE frame-based flow control.</p> <p>0 = This bit always returns 0 on reads.</p> <p>1 = Writing a 1 to this bit resets the Xoff request to the LAN controller, clearing bit 9 in this register.</p>																					
7:3	Reserved																					
2:0	<p>Flow Control Threshold — R/W. The LAN controller can generate a Flow Control Pause frame when its Receive FIFO is almost full. The value programmed into this field determines the number of bytes still available in the Receive FIFO when the Pause frame is generated.</p> <table border="1"> <thead> <tr> <th>Bits 2:0</th> <th>Free Bytes in Receive FIFO</th> <th>Comment</th> </tr> </thead> <tbody> <tr> <td>000</td> <td>0.50 KB</td> <td rowspan="6">Fast system (recommended default)</td> </tr> <tr> <td>001</td> <td>1.00 KB</td> </tr> <tr> <td>010</td> <td>1.25 KB</td> </tr> <tr> <td>011</td> <td>1.50 KB</td> </tr> <tr> <td>100</td> <td>1.75 KB</td> </tr> <tr> <td>101</td> <td>2.00 KB</td> </tr> <tr> <td>110</td> <td>2.25 KB</td> <td rowspan="2">Slow system</td> </tr> <tr> <td>111</td> <td>2.50 KB</td> </tr> </tbody> </table>	Bits 2:0	Free Bytes in Receive FIFO	Comment	000	0.50 KB	Fast system (recommended default)	001	1.00 KB	010	1.25 KB	011	1.50 KB	100	1.75 KB	101	2.00 KB	110	2.25 KB	Slow system	111	2.50 KB
Bits 2:0	Free Bytes in Receive FIFO	Comment																				
000	0.50 KB	Fast system (recommended default)																				
001	1.00 KB																					
010	1.25 KB																					
011	1.50 KB																					
100	1.75 KB																					
101	2.00 KB																					
110	2.25 KB	Slow system																				
111	2.50 KB																					

7.2.10 Power Management Driver (PMDR) Register

Offset Address: 1Bh Attribute: R/WC
 Default Value: 00h Size: 8 bits

The ICH4's internal LAN controller provides an indication in the PMDR that a wake-up event has occurred.

Bit	Description
7	Link Status Change Indication — R/WC. 0 = Software clears this bit by writing a 1 to the bit location 1 = The link status change bit is set following a change in link status.
6	Magic Packet — R/WC. 0 = Software clears this bit by writing a 1 to the bit location. 1 = This bit is set when a Magic Packet is received regardless of the Magic Packet wake-up disable bit in the configuration command and the PME Enable bit in the Power Management Control/Status Register.
5	Interesting Packet — R/WC. 0 = Software clears this bit by writing a 1 to the bit location. 1 = This bit is set when an “interesting” packet is received. Interesting packets are defined by the LAN controller packet filters.
4:1	Reserved
0	PME Status — R/WC. This bit is a reflection of the PME Status bit in the Power Management Control/Status Register (PMCSR). 0 = Software clears this bit by writing a 1 to the bit location. This also clears the PME Status bit in the PMCSR and de-asserts the PME signal. 1 = Set upon a wake-up event, independent of the PME Enable bit.

7.2.11 General Control Register

Offset Address: 1Ch Attribute: R/W
 Default Value: 00h Size: 8 bits

Bit	Description
7:4	Reserved. These bits should be set to 0000b.
3	LAN Connect Software Reset — R/W. 0 = Cleared by software to begin normal LAN Connect operating mode. Software must not attempt to access the LAN Connect interface for at least 1 ms after clearing this bit. 1 = Software can set this bit to force a reset condition on the LAN Connect interface.
2	Reserved. This bit should be set to 0.
1	Deep Power-Down on Link Down Enable — R/W. 0 = Disable 1 = The Intel® ICH4's internal LAN controller may enter a deep power-down state (sub-3 mA) in the D2 and D3 power states while the link is down. In this state, the LAN controller does not keep link integrity. This state is not supported for point-to-point connection of two end stations.
0	Reserved

7.2.12 General Status Register

Offset Address: 1Dh Attribute: RO
 Default Value: h Size: 8 bits

Bit	Description
7:3	Reserved
2	Duplex Mode — RO. This bit indicates the wire duplex mode. 0 = Half duplex 1 = Full duplex
1	Speed — RO. This bit indicates the wire speed. 0 = 10 Mbps 1 = 100 Mbps
0	Link Status Indication — RO. This bit indicates the status of the link. 0 = Invalid 1 = Valid

7.2.13 Statistical Counters

The ICH4's integrated LAN controller provides information for network management statistics by providing on-chip statistical counters that count a variety of events associated with both transmit and receive. The counters are updated by the LAN controller when it completes the processing of a frame (that is, when it has completed transmitting a frame on the link or when it has completed receiving a frame). The Statistical Counters are reported to the software on demand by issuing the Dump Statistical Counters command or Dump and Reset Statistical Counters command in the SCB Command Unit Command (CUC) field.

Table 7-6. Statistical Counters (Sheet 1 of 2)

ID	Counter	Description
0	Transmit Good Frames	This counter contains the number of frames that were transmitted properly on the link. It is updated only after the actual transmission on the link is completed, not when the frame was read from memory as is done for the Transmit Command Block status.
4	Transmit Maximum Collisions (MAXCOL) Errors	This counter contains the number of frames that were not transmitted because they encountered the configured maximum number of collisions.
8	Transmit Late Collisions (LATECOL) Errors	This counter contains the number of frames that were not transmitted since they encountered a collision later than the configured slot time.
12	Transmit Underrun Errors	A transmit underrun occurs because the system bus cannot keep up with the transmission. This counter contains the number of frames that were either not transmitted or retransmitted due to a transmit DMA underrun. If the LAN controller is configured to retransmit on underrun, this counter may be updated multiple times for a single frame.
16	Transmit Lost Carrier Sense (CRS)	This counter contains the number of frames that were transmitted by the LAN controller despite the fact that it detected the deassertion of CRS during the transmission.
20	Transmit Deferred	This counter contains the number of frames that were deferred before transmission due to activity on the link.
24	Transmit Single Collisions	This counter contains the number of transmitted frames that encountered one collision.
28	Transmit Multiple Collisions	This counter contains the number of transmitted frames that encountered more than one collision.
32	Transmit Total Collisions	This counter contains the total number of collisions that were encountered while attempting to transmit. This count includes late collisions and frames that encountered MAXCOL.
36	Receive Good Frames	This counter contains the number of frames that were received properly from the link. It is updated only after the actual reception from the link is completed and all the data bytes are stored in memory.
40	Receive CRC Errors	This counter contains the number of aligned frames discarded because of a CRC error. This counter is updated, if needed, regardless of the Receive Unit state. The Receive CRC Errors counter is mutually exclusive of the Receive Alignment Errors and Receive Short Frame Errors counters.
44	Receive Alignment Errors	This counter contains the number of frames that are both misaligned (for example, CRS deasserts on a non-octal boundary) and contain a CRC error. The counter is updated, if needed, regardless of the Receive Unit state. The Receive Alignment Errors counter is mutually exclusive of the Receive CRC Errors and Receive Short Frame Errors counters.

Table 7-6. Statistical Counters (Sheet 2 of 2)

ID	Counter	Description
48	Receive Resource Errors	This counter contains the number of good frames discarded due to unavailability of resources. Frames intended for a host whose Receive Unit is in the No Resources state fall into this category. If the LAN controller is configured to Save Bad Frames and the status of the received frame indicates that it is a bad frame, the Receive Resource Errors counter is not updated.
52	Receive Overrun Errors	This counter contains the number of frames known to be lost because the local system bus was not available. If the traffic problem persists for more than one frame, the frames that follow the first are also lost; however, because there is no lost frame indicator, they are not counted.
56	Receive Collision Detect (CDT)	This counter contains the number of frames that encountered collisions during frame reception.
60	Receive Short Frame Errors	This counter contains the number of received frames that are shorter than the minimum frame length. The Receive Short Frame Errors counter is mutually exclusive to the Receive Alignment Errors and Receive CRC Errors counters. A short frame will always increment only the Receive Short Frame Errors counter.
64	Flow Control Transmit Pause	This counter contains the number of Flow Control frames transmitted by the LAN controller. This count includes both the Xoff frames transmitted and Xon (PAUSE(0)) frames transmitted.
68	Flow Control Receive Pause	This counter contains the number of Flow Control frames received by the LAN controller. This count includes both the Xoff frames received and Xon (PAUSE(0)) frames received.
72	Flow Control Receive Unsupported	This counter contains the number of MAC Control frames received by the LAN controller that are not Flow Control Pause frames. These frames are valid MAC control frames that have the predefined MAC control Type value and a valid address but has an unsupported opcode.
76	Receive TCO Frames	This counter contains the number of TCO packets received by the LAN controller.
78	Transmit TCO Frames	This counter contains the number of TCO packets transmitted.

The Statistical Counters are initially set to zero by the ICH4's integrated LAN controller after reset. They cannot be preset to anything other than zero. The LAN controller increments the counters by internally reading them, incrementing them and writing them back. This process is invisible to the processor and PCI bus. In addition, the counters adhere to the following rules:

- The counters are wrap-around counters. After reaching FFFFFFFFh the counters wrap around to 0.
- The LAN controller updates the required counters for each frame. It is possible for more than one counter to be updated as multiple errors can occur in a single frame.
- The counters are 32 bits wide and their behavior is fully compatible with the IEEE 802.1 standard. The LAN controller supports all mandatory and recommend statistics functions through the status of the receive header and directly through these Statistical Counters.

The processor can access the counters by issuing a Dump Statistical Counters SCB command. This provides a "snapshot", in main memory, of the internal LAN controller statistical counters. The LAN controller supports 21 counters. The dump could consist of the either 16, 19, or all 21 counters, depending on the status of the Extended Statistics Counters and TCO Statistics configuration bits in the Configuration command.

Hub Interface to PCI Bridge Registers (D30:F0)

8

The hub interface to PCI Bridge resides in PCI Device 30, Function 0 on bus #0. This portion of the ICH4 implements the buffering and control logic between PCI and the hub interface. The arbitration for the PCI bus is handled by this PCI device. The PCI decoder in this device must decode the ranges for the hub interface. All register contents will be lost when core well power is removed.

8.1 PCI Configuration Registers (D30:F0)

Note: Registers that are not shown should be treated as Reserved (see [Section 6.2](#) for details).

Table 8-1. Hub Interface PCI Configuration Register Address Map (HUB-PCI—D30:F0) (Sheet 1 of 2)

Offset	Mnemonic	Register Name	Default	Type
00–01h	VID	Vendor ID	8086h	RO
02–03h	DID	Device ID	244Eh	RO
04–05h	CMD	PCI Device Command Register	0001h	R/W, RO
06–07h	PD_STS	PCI Device Status Register	0080h	R/WC, RO
08h	REVID	Revision ID	See Note	RO
0Ah	SCC	Sub Class Code	04h	RO
0Bh	BCC	Base Class Code	06h	RO
0Dh	PMLT	Primary Master Latency Timer	00h	RO
0Eh	HEADTYP	Header Type	01h	RO
18h	PBUS_NUM	Primary Bus Number	00h	RO
19h	SBUS_NUM	Secondary Bus Number	00h	R/W
1Ah	SUB_BUS_NUM	Subordinate Bus Number	00h	R/W
1Bh	SMLT	Secondary Master Latency Timer	00h	R/W
1Ch	IOBASE	IO Base Register	F0h	R/W, RO
1Dh	IOLIM	IO Limit Register	00h	R/W, RO
1E–1Fh	SECSTS	Secondary Status Register	0280h	R/WC, RO
20–21h	MEMBASE	Memory Base	FFF0h	R/W
22–23h	MEMLIM	Memory Limit	0000h	R/W
24–25h	PREF_MEM_BASE	Prefetchable Memory Base	0000h	RO
26–27h	PREF_MEM_MLT	Prefetchable Memory Limit	0000h	RO
30–31h	IOBASE_HI	I/O Base Upper 16 Bits	0000h	RO
32–33h	IOLIMIT_HI	I/O Limit Upper 16 Bits	0000h	RO

8.1.4 PD_STS—Primary Device Status Register (HUB-PCI—D30:F0)

Offset Address: 06–07h Attribute: R/WC, RO
 Default Value: 0080h Size: 16 bits

For the writable bits in this register, writing a 1 will clear the bit. Writing a 0 to the bit will have no effect.

Bit	Description
15	Detected Parity Error (DPE) — R/WC. 0 = Software clears this bit by writing a 1 to the bit location. 1 = Indicates that the Intel® ICH4 detected a parity error on the hub interface. This bit gets set even if the Parity Error Response bit (offset 04, bit 6) is not set.
14	Signaled System Error (SSE) — R/WC. 0 = Software clears this bit by writing a 1 to the bit location. 1 = An address, or command parity error, or special cycles data parity error has been detected on the PCI bus, and the Parity Error Response bit (D30:F0, Offset 04h, bit 6) is set. If this bit is set because of parity error and the D30:F0 SERR_EN bit (Offset 04h, bit 8) is also set, the ICH4 will generate an NMI (or SMI# if NMI routed to SMI#).
13	Received Master Abort (RMA) — R/WC. 0 = Software clears this bit by writing a 1 to the bit location. 1 = ICH4 received a master abort from the hub interface device.
12	Received Target Abort (RTA) — R/WC. 0 = Software clears this bit by writing a 1 to the bit location. 1 = ICH4 received a target abort from the hub interface device. The TCO logic can cause an SMI#, NMI, or interrupt based on this bit getting set.
11	Signaled Target Abort (STA) — R/WC. 0 = Software clears this bit by writing a 1 to the bit location. 1 = ICH4 signals a target abort condition on the hub interface.
10:9	DEVSEL# Timing Status (DEV_STS) — RO. 00h = Fast timing. This register applies to the hub interface; therefore, this field does not matter.
8	Master Data Parity Error Detected (MDPD) — R/WC. Since this register applies to the hub interface, the ICH4 must interpret this bit differently than it is in the PCI spec. 0 = Software clears this bit by writing a 1 to the bit location. 1 = ICH4 detects a parity error on the hub interface and the Parity Error Response bit in the Command Register (offset 04h, bit 6) is set.
7	Fast Back to Back Capable (FB2BC) — RO. Hardwired to 1.
6	User Definable Features (UDF) — RO. Hardwired to 0.
5	66 MHz Capable (66MHZ_CAP) — RO. Hardwired to 0.
4:0	Reserved

8.1.5 RID—Revision Identification Register (HUB-PCI—D30:F0)

Offset: 08h Attribute: RO
 Default Value: See Bit Description Size: 8 Bits

Bit	Description
7:0	Revision Identification Value — RO. Refer to the Intel® ICH4 specification update for the value of the Revision ID Register.e

8.1.6 SCC—Sub-Class Code Register (HUB-PCI—D30:F0)

Offset Address: 0Ah Attribute: RO
 Default Value: 04h Size: 8 bits

Bit	Description
7:0	Sub Class Code — RO. 8-bit value that indicates the category of bridge for the Intel® ICH4 hub interface to PCI bridge. The code is 04h indicating a PCI-to-PCI bridge.

8.1.7 BCC—Base-Class Code Register (HUB-PCI—D30:F0)

Offset Address: 0Bh Attribute: RO
 Default Value: 06h Size: 8 bits

Bit	Description
7:0	Base Class Code — RO. 8-bit value that indicates the type of device for the Intel® ICH4 hub interface to PCI bridge. The code is 06h indicating a bridge device.

8.1.8 PMLT—Primary Master Latency Timer Register (HUB-PCI—D30:F0)

Offset Address: 0Dh Attribute: RO
 Default Value: 00h Size: 8 bits

This register does not apply to hub interface.

Bit	Description
7:3	Master Latency Timer Count (MLTC). Not implemented.
2:0	Reserved

8.1.20 PREF_MEM_MLT—Prefetchable Memory Limit Register (HUB-PCI—D30:F0)

Offset Address: 26h–27h Attribute: R/W
 Default Value: 00000000h Size: 16 bit

Bit	Description
15:4	Prefetchable Memory Address Limit — RW. Defines the limit address of the prefetchable memory address range for PCI. These 12 bits correspond to address bits 31:20.
3:0	Reserved. RO

8.1.21 IOBASE_HI—I/O Base Upper 16 Bits Register (HUB-PCI—D30:F0)

Offset Address: 30–31h Attribute: RO
 Default Value: 0000h Size: 16 bits

Bit	Description
15:0	I/O Address Base Upper 16 Bits [31:16] — RO. Not supported; hardwired to 0.

8.1.22 IOLIM_HI—I/O Limit Upper 16 Bits Register (HUB-PCI—D30:F0)

Offset Address: 32–33h Attribute: RO
 Default Value: 0000h Size: 16 bits

Bit	Description
15:0	I/O Address Limit Upper 16 Bits [31:16] — RO. Not supported; hardwired to 0.

8.1.23 INT_LINE—Interrupt Line Register (HUB-PCI—D30:F0)

Offset Address: 3Ch Attribute: RO
 Default Value: 00h Size: 8 bits

Bit	Description
7:0	Interrupt Line (INT_LN) — RO. Hardwired to 00h. The bridge does not generate interrupts, and interrupts from downstream devices are routed around the bridge.

Bit	Description
3	VGA Enable — R/W. 0 = No VGA device on PCI. 1 = Indicates that the VGA device is on PCI. Therefore, the PCI to hub interface decoder will not accept memory cycles in the range A0000h–BFFFFh. Note that the ICH4 will never take I/O cycles in the VGA range from PCI.
2	ISA Enable — R/W. The ICH4 ignores this bit. However, this bit is read/write for software compatibility. Since the ICH4 forwards all I/O cycles that are not in the USB, AC '97, or IDE ranges to PCI, this bit would have no effect.
1	SERR# Enable — R/W. 0 = Disable 1 = If this bit is set AND bit 8 in CMD register (D30:F0 Offset 04h) is also set, the ICH4 will set the SSE bit in PD_STS register (D30:F0, offset 06h, bit 14) and also generate an NMI (or SMI# if NMI routed to SMI) when the SERR# signal is asserted.
0	Parity Error Response Enable — R/W. 0 = Disable 1 = Enable the hub interface to PCI bridge for parity error detection and reporting on the PCI bus.

8.1.25 HI1_CMD—Hub Interface 1 Command Control Register (HUB-PCI—D30:F0)

Offset Address: 40–43h Attribute: R/W, RO
Default Value: 00202802h Size: 32 bits

Bit	Description
31:24	Reserved
23:21	Hub ID — RO. This field identifies the Hub Interface ID number for the Intel® ICH4. The ICH4 will use this field for sending request packets from the ICH4, and for routing completion packets back from HI1.
20	Reserved
19:16	HI Timeslice — R/W. This field sets the HI arbiter time-slice value with 4 base-clock granularity. A value of 0h means that the time-slice is immediately expired and that the ICH4 will allow the other master's request to be serviced after every message.
15:14	HI_Width — RO. This field is hardwired to 00b, indicating that the HI interface is 8 bits wide.
13	HI_Rate_Valid — RO. Hardwired to 1.
12:10	HI_Rate — RO. Encoded value representing the clock-to-transfer rate of the HI1 interface: 010 = 1:4 The value is loaded at reset by sampling the capability of the device connected to the HI1 port. The value for this field is fixed for 4x mode only.
9:4	Reserved.
3:1	Max Data (MAXD) — RO. Hardwired to 001b. This field specifies the maximum amount of data that the ICH4 is allowed to burst in one packet on the hub interface. The ICH4 will always do 64-byte bursts.
0	Reserved

8.1.29 PCI_MAST_STS—PCI Master Status Register (HUB-PCI—D30:F0)

Offset Address: 82h Attribute: R/WC
 Default Value: 00h Size: 8 bits

Bit	Description
7	Internal PCI Master Request Status (INT_MREQ_STS) — R/WC. 0 = Software clears this bit by writing a 1 to it. 1 = The Intel® ICH4's internal DMA controller or LPC has requested use of the PCI bus.
6	Internal LAN Master Request Status (LAN_MREQ_STS) — R/WC. 0 = Software clears this bit by writing a 1 to it. 1 = The ICH4's internal LAN controller has requested use of the PCI bus.
5:0	PCI Master Request Status (PCI_MREQ_STS) — R/WC. Allows software to see if a particular bus master has requested use of the PCI bus. For example, bit 0 will be set if ICH4 has detected REQ[0]# asserted and bit 5 will be set if ICH4 detected REQ[5]# asserted. 0 = Software clears these bits by writing a 1 to the bit position. 1 = The associated PCI master has requested use of the PCI bus.

8.1.30 ERR_CMD—Error Command Register (HUB-PCI—D30:F0)

Offset Address: 90h Attribute: R/W
 Default Value: 00h Size: 8 bit
 Lockable: No Power Well: Core

This register configures the ICH4's Device 30 responses to various system errors. The actual assertion of the internal SERR# (routed to cause NMI# or SMI#) is enabled via the PCI Command register.

Bit	Description
7:3	Reserved
2	SERR# Enable on Receiving Target Abort (SERR_RTA_EN) — R/W. 0 = Disable. 1 = Enable. When SERR_EN is set, the Intel® ICH4 will report SERR# when SERR_RTA is set.
1:0	Reserved

8.1.31 ERR_STS—Error Status Register (HUB-PCI—D30:F0)

Offset Address:	92h	Attribute:	R/W
Default Value:	00h	Size:	8 bit
Lockable:	No	Power Well:	Core

This register records the cause of system errors in Device 30. The actual assertion of SERR# is enabled via the PCI Command register.

Bit	Description
7:3	Reserved
2	<p>SERR# Due to Received Target Abort (SERR_RTA) — R/W.</p> <p>0 = Software clears this bit by writing a 1 to it.</p> <p>1 = The Intel® ICH4 sets this bit when the ICH4 receives a target abort. If SERR_EN, the ICH4 will also generate an SERR# when SERR_RTA is set.</p>
1:0	Reserved

LPC Interface Bridge Registers (D31:F0)

9

The LPC Bridge function of the ICH4 resides in PCI Device 31:Function 0. This function contains many other functional units, such as DMA and Interrupt controllers, Timers, Power Management, System Management, GPIO, RTC, and LPC Configuration Registers.

Registers and functions associated with other functional units (USB UHCI, USB EHCI, IDE, etc.) are described in their respective sections.

9.1 PCI Configuration Registers (D31:F0)

Note: Registers that are not shown should be treated as Reserved (See Section 6.2 for details).

Table 9-1. LPC I/F PCI Configuration Register Address Map (LPC I/F—D31:F0) (Sheet 1 of 2)

Offset	Mnemonic	Register Name	Default	Type
00–01h	VID	Vendor ID	8086h	RO
02–03h	DID	Device ID	24C0h	RO
04–05h	PCICMD	PCI Command	000Fh	R/W, RO
06–07h	PCISTA	PCI Device Status	0280h	R/WC, RO
08h	RID	Revision ID	See Note	RO
09h	PI	Programming Interface	00h	RO
0Ah	SCC	Sub Class Code	01h	RO
0Bh	BCC	Base Class Code	06h	RO
0Eh	HEADT	Header Type	80h	RO
40–43h	PMBASE	ACPI Base Address	00000001h	R/W, RO
44h	ACPI_CNTL	ACPI Control	00h	R/W
4E–4Fh	BIOS_CNTL	BIOS Control	0000h	R/W
54h	TCO_CNTL	TCO Control	00h	R/W, RO
58–5Bh	GPIO_BASE	GPIO Base Address	00000001h	R/W
5Ch	GPIO_CNTL	GPIO Control Register	00h	R/W
60–63h	PIRQ[n]_ROUT	PIRQ[A–D] Routing Control	80808080h	R/W
64h	SIRQ_CNTL	Serial IRQ Control	10h	R/W
68–6Bh	PIRQ[n]_ROUT	PIRQ[E–H] Routing Control	80808080h	R/W
88h	D31_ERR_CFG	Device 31 Error Configuration	00h	R/W
8Ah	D31_ERR_STS	Device 31 Error Status	00h	R/WC
90–91h	PCI_DMA_C	PCI DMA Configuration Registers	0000h	R/W

Table 9-1. LPC I/F PCI Configuration Register Address Map (LPC I/F—D31:F0) (Sheet 2 of 2)

Offset	Mnemonic	Register Name	Default	Type
A0–CFh		Power Management Registers (See Section 9.8.1)		
D0–D3h	GEN_CNTL	General Control	00000000h	R/W
D4h	GEN_STA	General Status	0Xh	R/W-Special, RO
D5h	BACK_CNTL	Backed Up Control	Depends on Strap	R/W
D8h	RTC_CONF	Real Time Clock Configuration	00h	R/W
E0h	COM_DEC	LPC I/F COM Port Decode Ranges	00h	R/W
E1h	LPCFDD_DEC	LPC I/F FDD & LPT Decode Ranges	00h	R/W
E2h	SND_DEC	LPC I/F Sound Decode Ranges	00h	R/W
E3h	FWH_DEC_EN1	FWH Decode Enable 1	FFh	R/W
E4–E5h	GEN1_DEC	LPC I/F General 1 Decode Range	0000h	R/W
E6–E7h	LPC_EN	LPC I/F Enables	00h	R/W
E8–EBh	FWH_SEL1	FWH Select 1	00112233h	R/W
EC–EDh	GEN2_DEC	LPC I/F General 2 Decode Range	0000h	R/W
EE–EFh	FWH_SEL2	FWH Select 2	5678h	R/W
F0h	FWH_DEC_EN2	FWH Decode Enable 2	0Fh	R/W
F2h	FUNC_DIS	Function Disable Register	00h	R/W

NOTE: Refer to the ICH4 Specification Update for the value of the Revision ID Register.

9.1.1 VID—Vendor ID Register (LPC I/F—D31:F0)

Offset Address: 00–01h Attribute: RO
 Default Value: 8086h Size: 16 bit
 Lockable: No Power Well: Core

Bit	Description
15:0	Vendor Identification Value — RO. This is a 16-bit value assigned to Intel. Intel VID = 8086h

9.1.2 DID—Device ID Register (LPC I/F—D31:F0)

Offset Address: 02–03h Attribute: RO
 Default Value: 24C0h Size: 16 bit
 Lockable: No Power Well: Core

Bit	Description
15:0	Device Identification Value — RO. This is a 16-bit value assigned to the ICH4 LPC Bridge.

9.1.3 PCICMD—PCI COMMAND Register (LPC I/F—D31:F0)

Offset Address:	04–05h	Attribute:	R/W, RO
Default Value:	000Fh	Size:	16 bit
Lockable:	No	Power Well:	Core

Bit	Description
15:10	Reserved
9	Fast Back to Back Enable (FBE) — RO. Hardwired to 0.
8	SERR# Enable (SERR_EN) — R/W. 0 = Disable. 1 = Enable. Allow SERR# to be generated.
7	Wait Cycle Control (WCC) — RO. Hardwired to 0.
6	Parity Error Response (PER) — R/W. 0 = No action is taken when detecting a parity error. 1 = The Intel® ICH will take normal action when a parity error is detected.
5	VGA Palette Snoop (VPS) — RO. Hardwired to 0
4	Postable Memory Write Enable (PMWE) — RO. Hardwired to 0
3	Special Cycle Enable (SCE) — Hardwired to 1.
2	Bus Master Enable (BME) — RO. Hardwired to 1 to indicate that bus mastering cannot be disabled for function 0 (DMA/ISA Master)
1	Memory Space Enable (MSE) — RO. Hardwired to 1 to indicate that memory space cannot be disabled for Function 0 (LPC I/F)
0	I/O Space Enable (IOSE) — RO. Hardwired to 1 to indicate that the I/O space cannot be disabled for function 0 (LPC I/F)

9.1.4 PCISTA—PCI Device Status (LPC I/F—D31:F0)

Offset Address:	06–07h	Attribute:	R/WC, RO
Default Value:	0280h	Size:	16 bit
Lockable:	No	Power Well:	Core

Bit	Description
15	Detected Parity Error (DPE) — R/WC. 0 = This bit is cleared by software writing a 1 to the bit position. 1 = PERR# signal goes active. Set even if the PER bit is 0.
14	Signaled System Error (SSE) — R/WC. 0 = This bit is cleared by software writing a 1 to the bit position. 1 = Set by the Intel® ICH4 if the SERR_EN bit is set and the ICH4 generates an SERR# on function 0. The ERR_STS register can be read to determine the cause of the SERR#. The SERR# can be routed to cause SMI#, NMI, or interrupt.
13	Master Abort Status (RMA) — R/WC. 0 = This bit is cleared by software writing a 1 to the bit position. 1 = ICH4 generated a master abort on PCI due to LPC I/F master or DMA cycles.
12	Received Target Abort (RTA) — R/WC. 0 = This bit is cleared by software writing a 1 to the bit position. 1 = ICH4 received a target abort during LPC I/F master or DMA cycles to PCI.
11	Signaled Target Abort (STA) — R/WC. 0 = This bit is cleared by software writing a 1 to the bit position. 1 = ICH4 generated a target abort condition on PCI cycles claimed by the ICH4 for ICH4 internal registers or for going to LPC I/F.
10:9	DEVSEL# Timing Status (DEV_STS) — RO. 01 = Medium Timing.
8	Data Parity Error Detected (DPED) — R/WC. 0 = This bit is cleared by software writing a 1 to the bit position. 1 = Set when all three of the following conditions are true: - The ICH4 is the initiator of the cycle, - The ICH4 asserted PERR# (for reads) or observed PERR# (for writes), and - The PER bit is set.
7	Fast Back to Back Capable (FB2BC) — RO. Hardwired to 1. Indicates ICH4 as a target can accept fast back-to-back transactions.
6	User Definable Features (UDF) — RO. Hardwired to 0
5	66 MHz Capable (66MHZ_CAP) — RO. Hardwired to 0
4:0	Reserved

9.1.5 REVID—Revision ID Register (LPC I/F—D31:F0)

Offset Address:	08h	Attribute:	RO
Default Value:	See Bit Description	Size:	8 bits

Bit	Description
7:0	Revision Identification Value — RO. Refer to the Intel® ICH4 specification update for the value of the Revision ID Register.

9.1.10 PMBASE—ACPI Base Address (LPC I/F—D31:F0)

Offset Address:	40–43h	Attribute:	R/W, RO
Default Value:	00000001h	Size:	32 bit
Lockable:	No	Usage:	ACPI, Legacy
		Power Well:	Core

Sets base address for ACPI I/O registers, GPIO registers and TCO I/O registers. Can be mapped anywhere in the 64K I/O space on 128-byte boundaries.

Bit	Description
31:16	Reserved
15:7	Base Address — R/W. Provides 128 bytes of I/O space for ACPI, GPIO, and TCO logic. This is placed on a 128-byte boundary.
6:1	Reserved
0	Resource Indicator — RO. Tied to 1 to indicate I/O space.

9.1.11 ACPI_CNTL—ACPI Control (LPC I/F — D31:F0)

Offset Address:	44h	Attribute:	R/W
Default Value:	00h	Size:	8 bit
Lockable:	No	Usage:	ACPI, Legacy
		Power Well:	Core

Bit	Description
7:5	Reserved
4	ACPI Enable (ACPI_EN) — R/W. 0 = Disable. 1 = Decode of the I/O range pointed to by the ACPI Base register is enabled, and the ACPI power management function is enabled. Note that the APM power management ranges (B2/B3h) are always enabled and are not affected by this bit.
3	Reserved
2:0	SCI IRQ Select (SCI_IRQ_SEL) — R/W. This field specifies on which IRQ the SCI will internally appear. If not using the APIC, the SCI must be routed to IRQ9-11, and that interrupt is not sharable with the SERIRQ stream, but is shareable with other PCI interrupts. If using the APIC, the SCI can also be mapped to IRQ20-23, and can be shared with other interrupts. 000 = IRQ9 001 = IRQ10 010 = IRQ11 011 = Reserved 100 = IRQ20 (Only available if APIC enabled) 101 = IRQ21 (Only available if APIC enabled) 110 = IRQ22 (Only available if APIC enabled) 111 = IRQ23 (Only available if APIC enabled) NOTE: When the TCO interrupt is mapped to APIC interrupts 9, 10 or 11, the signal is in fact active high. When the TCO interrupt is mapped to IRQ 20, 21, 22, or 23 the signal is active low and can be shared with PCI interrupts that may be mapped to those same signals (IRQs).

9.1.12 BIOS_CNTL—BIOS Control Register (LPC I/F—D31:F0)

Offset Address:	4E–4Fh	Attribute:	R/W
Default Value:	0000h	Size:	16 bit
Lockable:	No	Power Well:	Core

Bit	Description
15:2	Reserved
1	BIOS Lock Enable (BLE) — R/W. 0 = Setting the BIOSWE will not cause Sums. Once set, this bit can only be cleared by a PCIRST#. 1 = Enables setting the BIOSWE bit to cause Sums.
0	BIOS Write Enable (BIOSWE) — R/W. 0 = Only read cycles result in FWH I/F cycles. 1 = Access to the BIOS space is enabled for both read and write cycles. When this bit is written from a 0 to a 1 and BIOS lock Enable (BLE) is also set, an SMI# is generated. This ensures that only SMI code can update BIOS.

9.1.13 TCO_CNTL — TCO Control (LPC I/F — D31:F0)

Offset Address:	54h	Attribute:	R/W
Default Value:	00h	Size:	8 bit
Lockable:	No	Power Well:	Core

Bits	Description
7:4	Reserved
3	TCO Interrupt Enable (TCO_INT_EN) — R/W. This bit enables/disables the TCO interrupt. 0 = Disables TCO interrupt. 1 = Enables TCO Interrupt, as selected by the TCO_INT_SEL field.
2:0	TCO Interrupt Select (TCO_INT_SEL) — R/W. This field specifies on which IRQ the TCO will internally appear. If not using the APIC, the TCO interrupt must be routed to IRQ9:11, and that interrupt is not sharable with the SERIRQ stream, but is shareable with other PCI interrupts. If using the APIC, the TCO interrupt can also be mapped to IRQ20:23, and can be shared with other interrupt. Note that if the TCOSCI_EN bit is set (bit 6 of the GPEO_EN register), then the TCO interrupt will be sent to the same interrupt as the SCI, and the TCO_INT_SEL bits will have no meaning. When the TCO interrupt is mapped to APIC interrupts 9, 10 or 11, the signal is active high. When the TCO interrupt is mapped to IRQ 20, 21, 22, or 23, the signal is active low and can be shared with PCI interrupts that may be mapped to those same signals (IRQs). 000 = IRQ9 001 = IRQ10 010 = IRQ11 011 = Reserved 100 = IRQ20 (Only available if APIC enabled) 101 = IRQ21 (Only available if APIC enabled) 110 = IRQ22 (Only available if APIC enabled) 111 = IRQ23 (Only available if APIC enabled)

9.1.14 GPIOBASE—GPIO Base Address (LPC I/F—D31:F0)

Offset Address: 58h–5Bh Attribute: R/W, RO
 Default Value: 00000001h Size: 32 bit
 Lockable: No Power Well: Core

Bit	Description
31:16	Reserved
15:6	Base Address — R/W. Provides the 64 bytes of I/O space for GPIO.
5:1	Reserved
0	Resource Indicator — RO. Hardwired to 1; indicates I/O space.

9.1.15 GPIO_CNTL—GPIO Control (LPC I/F—D31:F0)

Offset Address: 5Ch Attribute: R/W
 Default Value: 00h Size: 8 bit
 Lockable: No Power Well: Core

Bit	Description
7:5	Reserved
4	GPIO Enable (GPIO_EN) — R/W. This bit enables/disables decode of the I/O range pointed to by the GPIO base register and enables/disables the GPIO function. 0 = Disable. 1 = Enable.
3:0	Reserved

9.1.16 PIRQ[n]_ROUT—PIRQ[A,B,C,D] Routing Control (LPC I/F—D31:F0)

Offset Address: PIRQA–60h, PIRQB–61h, Attribute: R/W
 PIRQC–62h, PIRQD–63h Size: 8 bit
 Default Value: 80h Power Well: Core
 Lockable: No

Bit	Description																
7	Interrupt Routing Enable (IRQEN) — R/W. 0 = The corresponding PIRQ is routed to one of the ISA-compatible interrupts specified in bits[3:0]. 1 = The PIRQ is not routed to the 8259. NOTE: BIOS must program this bit to 0 during POST for any of the PIRQs that are being used. The value of this bit may subsequently be changed by the OS when setting up for I/O APIC interrupt delivery mode.																
6:4	Reserved																
3:0	IRQ Routing — R/W. (ISA compatible) <table style="width: 100%; border: none;"> <tr> <td style="width: 50%;">0000 = Reserved</td> <td style="width: 50%;">1000 = Reserved</td> </tr> <tr> <td>0001 = Reserved</td> <td>1001 = IRQ9</td> </tr> <tr> <td>0010 = Reserved</td> <td>1010 = IRQ10</td> </tr> <tr> <td>0011 = IRQ3</td> <td>1011 = IRQ11</td> </tr> <tr> <td>0100 = IRQ4</td> <td>1100 = IRQ12</td> </tr> <tr> <td>0101 = IRQ5</td> <td>1101 = Reserved</td> </tr> <tr> <td>0110 = IRQ6</td> <td>1110 = IRQ14</td> </tr> <tr> <td>0111 = IRQ7</td> <td>1111 = IRQ15</td> </tr> </table>	0000 = Reserved	1000 = Reserved	0001 = Reserved	1001 = IRQ9	0010 = Reserved	1010 = IRQ10	0011 = IRQ3	1011 = IRQ11	0100 = IRQ4	1100 = IRQ12	0101 = IRQ5	1101 = Reserved	0110 = IRQ6	1110 = IRQ14	0111 = IRQ7	1111 = IRQ15
0000 = Reserved	1000 = Reserved																
0001 = Reserved	1001 = IRQ9																
0010 = Reserved	1010 = IRQ10																
0011 = IRQ3	1011 = IRQ11																
0100 = IRQ4	1100 = IRQ12																
0101 = IRQ5	1101 = Reserved																
0110 = IRQ6	1110 = IRQ14																
0111 = IRQ7	1111 = IRQ15																

9.1.17 SERIRQ_CNTL—Serial IRQ Control (LPC I/F—D31:F0)

Offset Address:	64h	Attribute:	R/W
Default Value:	10h	Size:	8 bit
Lockable:	No	Power Well:	Core

Bit	Description
7	Serial IRQ Enable (SIRQEN) — R/W. 0 = The buffer is input only and internally SERIRQ will be a 1. 1 = Serial IRQs will be recognized. The SERIRQ pin will be configured as SERIRQ.
6	Serial IRQ Mode Select (SIRQMD) — R/W. 0 = The serial IRQ machine will be in quiet mode. 1 = The serial IRQ machine will be in continuous mode. NOTE: For systems using Quiet Mode, this bit should be set to 1 (Continuous Mode) for at least one frame after coming out of reset before switching back to Quiet Mode. Failure to do so will result in the Intel® ICH4 not recognizing SERIRQ interrupts.
5:2	Serial IRQ Frame Size (SIRQSZ) — R/W. Fixed field that indicates the size of the SERIRQ frame. In the ICH4, this field needs to be programmed to 21 frames (0100). This is an offset from a base of 17 which is the smallest data frame size.
1:0	Start Frame Pulse Width (SFPW) — R/W. This is the number of PCI clocks that the SERIRQ pin will be driven low by the serial IRQ machine to signal a start frame. In continuous mode, the ICH4 will drive the start frame for the number of clocks specified. In quiet mode, the ICH4 will drive the start frame for the number of clocks specified minus one, as the first clock was driven by the peripheral. 00 = 4 clocks 01 = 6 clocks 10 = 8 clocks 11 = Reserved

9.1.18 PIRQ[n]_ROUT—PIRQ[E,F,G,H] Routing Control (LPC I/F—D31:F0)

Offset Address:	PIRQE—68h, PIRQF—69h, PIRQG—6Ah, PIRQH—6Bh	Attribute:	R/W
Default Value:	80h	Size:	8 bit
Lockable:	No	Power Well:	Core

Bit	Description
7	Interrupt Routing Enable (IRQEN) — R/W. 0 = The corresponding PIRQ is routed to one of the ISA-compatible interrupts specified in bits[3:0]. 1 = The PIRQ is not routed to the 8259. NOTE: BIOS must program this bit to 0 during POST for any of the PIRQs that are being used. The value of this bit may subsequently be changed by the OS when setting up for I/O APIC interrupt delivery mode.
6:4	Reserved
3:0	IRQ Routing — R/W. (ISA compatible) 0000 = Reserved 1000 = Reserved 0001 = Reserved 1001 = IRQ9 0010 = Reserved 1010 = IRQ10 0011 = IRQ3 1011 = IRQ11 0100 = IRQ4 1100 = IRQ12 0101 = IRQ5 1101 = Reserved 0110 = IRQ6 1110 = IRQ14 0111 = IRQ7 1111 = IRQ15

9.1.19 D31_ERR_CFG—Device 31 Error Configuration Register (LPC I/F—D31:F0)

Offset Address:	88h	Attribute:	R/W
Default Value:	00h	Size:	8 bit
Lockable:	No	Power Well:	Core

This register configures the ICH4's Device 31 responses to various system errors. The actual assertion of SERR# is enabled via the PCI Command register

Bit	Description
7:3	Reserved
2	SERR# on Received Target Abort Enable (SERR_RTA_EN) — R/W. 0 = Disable. No SERR# assertion on Received Target Abort. 1 = The Intel® ICH4 will generate SERR# when SERR_RTA is set if SERR_EN is set.
1	SERR# on Delayed Transaction Timeout Enable (SERR_DTT_EN) — R/W. 0 = Disable. No SERR# assertion on Delayed Transaction Timeout. 1 = The ICH4 will generate SERR# when SERR_DTT bit is set if SERR_EN is set.
0	Reserved

9.1.20 D31_ERR_STS—Device 31 Error Status Register (LPC I/F—D31:F0)

Offset Address:	8Ah	Attribute:	R/WC
Default Value:	00h	Size:	8 bit
Lockable:	No	Power Well:	Core

This register configures the ICH4's Device 31 responses to various system errors. The actual assertion of SERR# is enabled via the PCI Command register.

Bit	Description
7:3	Reserved
2	SERR# Due to Received Target Abort (SERR_RTA) — R/WC. 0 = Software clears this bit by writing a 1 to the bit location. 1 = The Intel® ICH4 sets this bit when it receives a target abort. If SERR_EN, the ICH4 will also generate an SERR# when SERR_RTA is set.
1	SERR# Due to Delayed Transaction Timeout (SERR_DTT) — R/WC. 0 = Software clears this bit by writing a 1 to the bit location. 1 = When a PCI master does not return for the data within 1 ms of the cycle's completion, the ICH4 clears the delayed transaction and sets this bit. If both SERR_DTT_EN and SERR_EN are set, then ICH4 will also generate an SERR# when SERR_DTT is set.
0	Reserved

9.1.21 PCI_DMA_CFG—PCI DMA Configuration (LPC I/F—D31:F0)

Offset Address:	90h–91h	Attribute:	R/W
Default Value:	0000h	Size:	16 bit
Lockable:	No	Power Well:	Core

Bit	Description
15:14	Channel 7 Select — R/W. 00 = Reserved 01 = PC/PCI DMA 10 = Reserved 11 = LPC I/F DMA
13:12	Channel 6 Select — R/W. Same bit decode as for Channel 7
11:10	Channel 5 Select — R/W. Same bit decode as for Channel 7
9:8	Reserved
7:6	Channel 3 Select — R/W. Same bit decode as for Channel 7
5:4	Channel 2 Select — R/W. Same bit decode as for Channel 7
3:2	Channel 1 Select — R/W. Same bit decode as for Channel 7
1:0	Channel 0 Select — R/W. Same bit decode as for Channel 7

9.1.22 GEN_CNTL — General Control Register (LPC I/F — D31:F0)

Offset Address:	D0h–D3h	Attribute:	R/W
Default Value:	00000000h	Size:	32 bit
Lockable:	No	Power Well:	Core

Bit	Description
31:26	Reserved
25	<p>REQ[5]#/GNT[5]# PC/PCI Protocol Select (PCPCIB_SEL) — R/W.</p> <p>0 = REQ[5]#/GNT[5]# pins function as a standard PCI REQ/GNT signal pair.</p> <p>1 = PCI REQ[5]#/GNT[5]# signal pair use the PC/PCI protocol as REQ[B]#/GNT[B]. The corresponding bits in the GPIO_USE_SEL register must also be set to a 0. If the corresponding bits in the GPIO_USE_SEL register are set to a 1, then the signals will be used as a GPI and GPO.</p>
24	<p>Hide ISA Bridge (HIDE_ISA) — R/W.</p> <p>0 = The Intel® ICH4 does not prevent AD22 from asserting during configuration cycles to the PCI-to-ISA bridge.</p> <p>1 = Software sets this bit to 1 to disable configuration cycle from being claimed by a PCI-to-ISA bridge. This prevents the OS PCI PnP from getting confused by seeing two ISA bridges. It is required for the ICH4 PCI address line AD22 to connect to the PCI-to-ISA bridge's IDSEL input. When this bit is set, the ICH4 will not assert AD22 during configuration cycles to the PCI-to-ISA bridge.</p>
23:22	Reserved
21	<p>CPU Break Event Indication Enable (FERR#-MUX-EN) — R/W.</p> <p>0 = Disable. The ICH4 does not examine the FERR# signal during C2. (Default)</p> <p>1 = Enables the ICH4 to examine the FERR# signal during a C2 state as a break event. (See Section 5.12.5 for details.)</p>
20	Reserved
19:18	SCRATCHPAD. These bits are provided for possible future use.
17:14	Reserved
13	<p>Coprocessor Error Enable (COPR_ERR_EN) — R/W.</p> <p>0 = FERR# will not generate IRQ13 nor IGNNE#.</p> <p>1 = When FERR# is low, ICH4 generates IRQ13 internally and holds it until an I/O write to port F0h. It will also drive IGNNE# active.</p>
12	<p>Keyboard IRQ1 Latch Enable (IRQ1LEN) — R/W.</p> <p>0 = IRQ1 bypasses the latch.</p> <p>1 = The active edge of IRQ1 is latched and held until a port 60h read.</p>
11	<p>Mouse IRQ12 Latch Enable (IRQ12LEN) — R/W.</p> <p>0 = IRQ12 bypasses the latch.</p> <p>1 = The active edge of IRQ12 is latched and held until a port 60h read.</p>
10:9	Reserved

Bit	Description
8	<p>APIC Enable (APIC_EN) — R/W.</p> <p>0 = Disables internal I/O (x) APIC.</p> <p>1 = Enables the internal I/O (x) APIC and its address decode.</p> <p>The following behavioral rules apply for bits 8 and 7 in this register:</p> <ul style="list-style-type: none"> • Rule 1: If bit 8 is 0, the ICH4 does not decode any of the registers associated with the I/O APIC or I/O (x) APIC. The state of bit 7 is “Don’t Care” in this case. • Rule 2: If bit 8 is 1 and bit 7 is 0, the ICH4 decodes the memory space associated with the I/O APIC, but not the extra registers associated I/O (x) APIC. • Rule 3: If bit 8 is 1 and bit 7 is 1, the ICH4 decodes the memory space associated with both the I/O APIC and the I/O (x) APIC. This also enables PCI masters to write directly to the register to cause interrupts (PCI Message Interrupt). <p>NOTE: There is no separate way to disable PCI Message Interrupts if the I/O (x) APIC is enabled. This is not considered necessary.</p>
7	<p>I/O (x) Extension Enable (XAPIC_EN) — R/W.</p> <p>0 = The I/O (x) APIC extensions are not supported.</p> <p>1 = Enables the extra features (beyond standard I/O APIC) associated with the I/O (x) APIC.</p> <p>NOTE: This bit is only valid if the APIC_EN bit is also set to 1.</p>
6	<p>Alternate Access Mode Enable (ALTACC_EN) — R/W.</p> <p>0 = Alt Access Mode Disabled (default). ALT access mode allows reads to otherwise unreadable registers and writes otherwise unwritable registers.</p> <p>1 = Alt Access Mode Enable.</p>
5:4	Reserved
3	Reserved — RO. Reset 0.
2	<p>DMA Collection Buffer Enable (DCB_EN) — R/W.</p> <p>0 = DCB disabled.</p> <p>1 = Enables DMA Collection Buffer (DCB) for LPC I/F and PC/PCI DMA.</p>
1	<p>Delayed Transaction Enable (DTE) — R/W.</p> <p>0 = Delayed transactions disabled.</p> <p>1 = ICH4 enables delayed transactions for internal register, FWH and LPC I/F accesses.</p>
0	<p>Positive Decode Enable (POS_DEC_EN) — R/W.</p> <p>0 = The ICH4 will perform subtractive decode on the PCI bus and forward the cycles to LPC I/F if not to an internal register or other known target on the LPC I/F. Accesses to internal registers and to known LPC I/F devices will still be positively decoded.</p> <p>1 = Enables ICH4 to only perform positive decode on the PCI bus.</p>

9.1.23 GEN_STA—General Status Register (LPC I/F—D31:F0)

Offset Address: D4h Attribute: RO, R/W-Special
 Default Value: 0Xh Size: 8 bit
 Lockable: No Power Well: Core

Bit	Description
7:3	Reserved
2	SAFE_MODE — RO. 0 = Intel® ICH4 sampled AC_SDOOUT low on the rising edge of PWROK. 1 = ICH4 sampled AC_SDOOUT high on the rising edge of PWROK. ICH4 will force FREQ_STRAP[3:0] bits to all 1s (safe mode multiplier).
1	NO_REBOOT — R/W-Special. 0 = Normal TCO Timer reboot functionality (reboot after 2nd TCO timeout). This bit cannot be set to 0 by software if the strap is set to No Reboot. 1 = ICH4 will disable the TCO Timer system reboot feature. This bit is set either by hardware when SPKR is sampled high on the rising edge of PWROK, or by software writing a 1 to the bit.
0	Reserved

9.1.24 BACK_CNTL—Backed Up Control Register (LPC I/F—D31:F0)

Offset Address: D5h Attribute: R/W
 Default Value: 0Fh
 (upon RTCRST# assertion low)
 2Fh
 (if Safe Mode Strap is active)
 Lockable: No Size: 8 bit
 Power Well: RTC

Bit	Description
7	Reserved. Read only as 0.
6	Reserved. Read only as 0.
5	Top-Block Swap Mode (TOP_SWAP) — R/W. 0 = Intel® ICH4 will not invert A16. This bit is cleared by RTCRST# assertion, but not by any other type of reset. 1 = ICH4 inverts A16 for cycles targeting FWH BIOS space (Does not affect accesses to FWH feature space).
4	CPU BIST Enable (CPU_BIST_EN) — R/W. 0 = Disable. 1 = The INIT# signal will be driven active when CPURST# is active. INIT# will go inactive with the same timings as the other CPU I/F signals (Hold Time after CPURST# inactive). Note that CPURST# is generated by the memory controller hub, but the ICH4 has a hub interface special cycle that allows the ICH4 to control the assertion/deassertion of CPURST#. NOTE: This bit is in the Resume well and is reset by RSMRST#, but not by PCIRST# nor CF9h writes.
3:0	CPU Frequency Strap (FREQ_STRAP[3:0]) — R/W. These bits determine the internal frequency multiplier of the processor. These bits can be reset to 1111 based on an external pin strap or via the RTCRST# input signal. Software must program this field based on the processor's specified frequency. Note that this field is only writable when the SAFE_MODE bit is cleared to 0, and SAFE_MODE is only cleared by PWROK rising edge. These bits are in the RTC well.

9.1.25 RTC_CONF—RTC Configuration Register (LPC I/F—D31:F0)

Offset Address:	D8h	Attribute:	R/W, R/W-Special
Default Value:	00h	Size:	8 bit
Lockable:	Yes	Power Well:	Core

Bit	Description
7:5	Reserved
4	Upper 128-byte Lock (U128LOCK) — R/W-Special. 0 = Access to these bytes in the upper CMOS RAM range have not been locked. 1 = Locks reads and writes to bytes 38h–3Fh in the upper 128-byte bank of the RTC CMOS RAM. Write cycles to this range will have no effect and read cycles will not return any particular guaranteed value. This is a write once register that can only be reset by a hardware reset.
3	Lower 128-byte Lock (L128LOCK) — R/W-Special. 0 = Access to these bytes in the lower CMOS RAM range have not been locked. 1 = Locks reads and writes to bytes 38h–3Fh in the lower 128-byte bank of the RTC CMOS RAM. Write cycles to this range will have no effect and read cycles will not return any particular guaranteed value. This is a write once register that can only be reset by a hardware reset.
2	Upper 128-byte Enable (U128E) — R/W. 0 = Disable. 1 = Enables access to the upper 128-byte bank of RTC CMOS RAM.
1:0	Reserved

9.1.26 COM_DEC—LPC I/F Communication Port Decode Ranges (LPC I/F—D31:F0)

Offset Address:	E0h	Attribute:	R/W
Default Value:	00h	Size:	8 bit
Lockable:	No	Power Well:	Core

Bit	Description
7	Reserved
6:4	COMB Decode Range — R/W. This field determines which range to decode for the COMB Port. 000 = 3F8h–3FFh (COM1) 001 = F8h–2FFh (COM2) 010 = 220h–227h 011 = 228h–22Fh 100 = 238h–23Fh 101 = 2E8h–2EFh (COM4) 110 = 338h–33Fh 111 = 3E8h–3EFh (COM3)
3	Reserved
2:0	COMA Decode Range — R/W. This field determines which range to decode for the COMA Port. 000 = 3F8h–3FFh (COM1) 001 = 2F8h–2FFh (COM2) 010 = 220h–227h 011 = 228h–22Fh 100 = 238h–23Fh 101 = 2E8h–2EFh (COM4) 110 = 338h–33Fh 111 = 3E8h–3EFh (COM3)

9.1.27 FDD/LPT_DEC—LPC I/F FDD & LPT Decode Ranges (LPC I/F—D31:F0)

Offset Address: E1h Attribute: R/W
 Default Value: 00h Size: 8 bit
 Lockable: No Power Well: Core

Bit	Description
7:5	Reserved
4	FDD Decode Range — R/W. Determines which range to decode for the FDD Port 0 = 3F0h–3F5h, 3F7h (Primary) 1 = 370h–2FFh (Secondary)
3:2	Reserved
1:0	LPT Decode Range — R/W. This field determines which range to decode for the LPTPort. 00 = 378h–37Fh and 778h–77Fh 01 = 278h–27Fh (port 279h is read only) and 678h–67Fh 10 = 3BCh–3BEh and 7BCh–7BEh 11 = Reserved

9.1.28 SND_DEC—LPC I/F Sound Decode Ranges (LPC I/F—D31:F0)

Offset Address: E2h Attribute: R/W
 Default Value: 00h Size: 8 bit
 Lockable: No Power Well: Core

Bit	Description
7:6	Reserved
5:4	MSS Decode Range — R/W. This field determines which range to decode for the Microsoft Sound System (MSS) 00 = 530h–537h 01 = 604h–60Bh 10 = E80h–E87h 11 = F40h–F47h
3	MIDI Decode Range — R/W. This bit determines which range to decode for the Midi Port 0 = 330h–331h 1 = 300h–301h
2	Reserved
1:0	SB16 Decode Range — R/W. This field determines which range to decode for the Sound Blaster 16 (SB16) Port 00 = 220h–233h 01 = 240h–253h 10 = 260h–273h 11 = 280h–293h

9.1.29 FWH_DEC_EN1—FWH Decode Enable 1 Register (LPC I/F—D31:F0)

Offset Address: E3h Attribute: R/W
 Default Value: FFh Size: 8 bits

This register determines which memory ranges will be decoded on the PCI bus and forwarded to the FWH. The ICH4 will subtractively decode cycles on PCI unless POS_DEC_EN is set to 1.

Bit	Description
7	FWH_F8_EN — R/W. Enables decoding two 512 KB FWH memory ranges, and one 128KB memory range. 0 = Disable 1 = Enable the following ranges for the FWH FFF80000h–FFFFFFFFh FFB80000h–FFBFFFFFFh 000E0000h–000FFFFFFh
6	FWH_F0_EN — R/W. Enables decoding two 512 KB FWH memory ranges. 0 = Disable. 1 = Enable the following ranges for the FWH: FFF00000h–FFF7FFFFh FFB00000h–FFB7FFFFh
5	FWH_E8_EN — R/W. Enables decoding two 512 KB FWH memory ranges. 0 = Disable. 1 = Enable the following ranges for the FWH: FFE80000h–FFEFFFFFFh FFA80000h–FFAFFFFFFh
4	FWH_E0_EN — R/W. Enables decoding two 512 KB FWH memory ranges. 0 = Disable. 1 = Enable the following ranges for the FWH: FFE00000h–FFE7FFFFh FFA00000h–FFA7FFFFh
3	FWH_D8_EN — R/W. Enables decoding two 512 KB FWH memory ranges. 0 = Disable. 1 = Enable the following ranges for the FWH FFD80000h–FFDFFFFFFh FF980000h–FF9FFFFFFh
2	FWH_D0_EN — R/W. Enables decoding two 512KB FWH memory ranges. 0 = Disable. 1 = Enable the following ranges for the FWH FFD00000h–FFD7FFFFh FF900000h–FF97FFFFh
1	FWH_C8_EN — R/W. Enables decoding two 512KB FWH memory ranges. 0 = Disable. 1 = Enable the following ranges for the FWH FFC80000h–FFCFFFFFFh FF880000h–FF8FFFFFFh
0	FWH_C0_EN — R/W. Enables decoding two 512 KB FWH memory ranges. 0 = Disable. 1 = Enable the following ranges for the FWH FFC00000h–FFC7FFFFh FF800000h–FF87FFFFh

9.1.30 GEN1_DEC—LPC I/F Generic Decode Range 1 Register (LPC I/F—D31:F0)

Offset Address: E4h–E5h Attribute: R/W
 Default Value: 00h Size: 16 bit
 Lockable: Yes Power Well: Core

Bit	Description
15:7	Generic I/O Decode Range 1 Base Address (GEN1_BASE) — R/W. This address is aligned on a 128-byte boundary, and must have address lines 31:16 as 0. NOTE: This generic decode is for I/O addresses only, not memory addresses. The size of this range is 128 bytes.
6:1	Reserved
0	Generic Decode Range 1 Enable (GEN1_EN) — R/W. 0 = Disable. 1 = Enable the GEN1 I/O range to be forwarded to the LPC I/F

9.1.31 LPC_EN—LPC I/F Enables Register (LPC I/F—D31:F0)

Offset Address: E6h–E7h Attribute: R/W
 Default Value: 00h Size: 16 bit
 Lockable: Yes Power Well: Core

Bit	Description
15:14	Reserved
13	CNF2_LPC_EN — R/W. 0 = Disable. 1 = Enables the decoding of the I/O locations 4Eh and 4Fh to the LPC interface. This range is used for a microcontroller.
12	CNF1_LPC_EN — R/W. 0 = Disable. 1 = Enables the decoding of the I/O locations 2Eh and 2Fh to the LPC interface. This range is used for Super I/O devices.
11	MC_LPC_EN — R/W. 0 = Disable. 1 = Enables the decoding of the I/O locations 62h and 66h to the LPC interface. This range is used for a microcontroller.
10	KBC_LPC_EN — R/W. 0 = Disable. 1 = Enables the decoding of the I/O locations 60h and 64h to the LPC interface. This range is used for a microcontroller.
9	GAMEH_LPC_EN — R/W. 0 = Disable. 1 = Enables the decoding of the I/O locations 208h to 20Fh to the LPC interface. This range is used for a gameport.
8	GAMEL_LPC_EN — R/W. 0 = Disable. 1 = Enables the decoding of the I/O locations 200h to 207h to the LPC interface. This range is used for a gameport.

Bit	Description
7	ADLIB_LPC_EN — R/W. 0 = Disable. 1 = Enables the decoding of the I/O locations 388h–38Bh to the LPC interface.
6	MSS_LPC_EN — R/W. 0 = Disable. 1 = Enables the decoding of the MSS range to the LPC interface. This range is selected in the LPC_Sound Decode Range Register.
5	MIDI_LPC_EN — R/W. 0 = Disable. 1 = Enables the decoding of the MIDI range to the LPC interface. This range is selected in the LPC_Sound Decode Range Register.
4	SB16_LPC_EN — R/W. 0 = Disable. 1 = Enables the decoding of the SB16 range to the LPC interface. This range is selected in the LPC_Sound Decode Range Register.
3	FDD_LPC_EN — R/W. 0 = Disable. 1 = Enables the decoding of the FDD range to the LPC interface. This range is selected in the LPC_FDD/LPT Decode Range Register.
2	LPT_LPC_EN — R/W. 0 = Disable. 1 = Enables the decoding of the LPT range to the LPC interface. This range is selected in the LPC_FDD/LPT Decode Range Register.
1	COMB_LPC_EN — R/W. 0 = Disable. 1 = Enables the decoding of the COMB range to the LPC interface. This range is selected in the LPC_COM Decode Range Register.
0	COMA_LPC_EN — R/W. 0 = Disable. 1 = Enables the decoding of the COMA range to the LPC interface. This range is selected in the LPC_COM Decode Range Register.

9.1.32 FWH_SEL1—FWH Select 1 Register (LPC I/F—D31:F0)

Offset Address: E8h Attribute: R/W, RO
 Default Value: 00112233h Size: 32 bits

Bit	Description
31:28	FWH_F8_IDSEL — RO. IDSEL for two 512 KB FWH memory ranges and one 128 KB memory range. This field is fixed at 0000. The IDSEL programmed in this field addresses the following memory ranges: FFF8 0000h–FFFF FFFFh FFB8 0000h–FFBF FFFFh 000E 0000h–000F FFFFh
27:24	FWH_F0_IDSEL — R/W. IDSEL for two 512 KB FWH memory ranges. The IDSEL programmed in this field addresses the following memory ranges: FFF0 0000h–FFF7 FFFFh FFB0 0000h–FFB7 FFFFh
23:20	FWH_E8_IDSEL — R/W. IDSEL for two 512 KB FWH memory ranges. The IDSEL programmed in this field addresses the following memory ranges: FFE8 0000h–FFEF FFFFh FFA8 0000h–FFAF FFFFh
19:16	FWH_E0_IDSEL — R/W. IDSEL for two 512 KB FWH memory ranges. The IDSEL programmed in this field addresses the following memory ranges: FFE0 0000h–FFE7 FFFFh FFA0 0000h–FFA7 FFFFh
15:12	FWH_D8_IDSEL — R/W. IDSEL for two 512 KB FWH memory ranges. The IDSEL programmed in this field addresses the following memory ranges: FFD8 0000h–FFDF FFFFh FF98 0000h–FF9F FFFFh
11:8	FWH_D0_IDSEL — R/W. IDSEL for two 512 KB FWH memory ranges. The IDSEL programmed in this field addresses the following memory ranges: FFD0 0000h–FFD7 FFFFh FF90 0000h–FF97 FFFFh
7:4	FWH_C8_IDSEL — R/W. IDSEL for two 512 KB FWH memory ranges. The IDSEL programmed in this field addresses the following memory ranges: FFC8 0000h–FFCF FFFFh FF88 0000h–FF8F FFFFh
3:0	FWH_C0_IDSEL — R/W. IDSEL for two 512 KB FWH memory ranges. The IDSEL programmed in this field addresses the following memory ranges: FFC0 0000h–FFC7 FFFFh FF80 0000h–FF87 FFFFh

9.1.33 GEN2_DEC—LPC I/F Generic Decode Range 2 Register (LPC I/F—D31:F0)

Offset Address:	ECh–EDh	Attribute:	R/W
Default Value:	00h	Size:	16 bit
Lockable:	Yes	Power Well:	Core

Bit	Description
15:4	Generic I/O Decode Range 2 Base Address (GEN2_BASE) — R/W. This address is aligned on a 64-byte boundary, and must have address lines 31:16 as 0. Note that this generic decode is for I/O addresses only, not memory addresses. The size of this range is 16 bytes.
3:1	Reserved. Read as 0
0	Generic I/O Decode Range 2 Enable (GEN2_EN) — R/W. 0 = Disable. 1 = Accesses to the GEN2 I/O range will be forwarded to the LPC I/F

9.1.34 FWH_SEL2—FWH Select 2 Register (LPC I/F—D31:F0)

Offset Address:	EEh–EFh	Attribute:	R/W
Default Value:	4567h	Size:	32 bits

Bit	Description
15:12	FWH_70_IDSEL — R/W. IDSEL for two 1M FWH memory ranges. The IDSEL programmed in this field addresses the following memory ranges: FF70 0000h–FF7F FFFFh FF30 0000h–FF3F FFFFh
11:8	FWH_60_IDSEL — R/W. IDSEL for two 1M FWH memory ranges. The IDSEL programmed in this field addresses the following memory ranges: FF60 0000h–FF6F FFFFh FF20 0000h–FF2F FFFFh
7:4	FWH_50_IDSEL — R/W. IDSEL for two 1M FWH memory ranges. The IDSEL programmed in this field addresses the following memory ranges: FF50 0000h–FF5F FFFFh FF10 0000h–FF1F FFFFh
3:0	FWH_40_IDSEL — R/W. IDSEL for two 1M FWH memory ranges. The IDSEL programmed in this field addresses the following memory ranges: FF40 0000h–FF4F FFFFh FF00 0000h–FF0F FFFFh

9.1.35 FWH_DEC_EN2—FWH Decode Enable 2 Register (LPC I/F—D31:F0)

Offset Address: F0h Attribute: R/W
 Default Value: 0Fh Size: 8 bits

This register determines which memory ranges will be decoded on the PCI bus and forwarded to the FWH. The ICH4 will subtractively decode cycles on PCI unless POS_DEC_EN is set to 1.

Bit	Description
7:4	Reserved
3	FWH_70_EN — R/W. Enables decoding two 1M FWH memory ranges. 0 = Disable. 1 = Enable the following ranges for the FWH FF70 0000h–FF7F FFFFh FF30 0000h–FF3F FFFFh
2	FWH_60_EN — R/W. Enables decoding two 1M FWH memory ranges. 0 = Disable. 1 = Enable the following ranges for the FWH FF60 0000h–FF6F FFFFh FF20 0000h–FF2F FFFFh
1	FWH_50_EN — R/W. Enables decoding two 1M FWH memory ranges. 0 = Disable. 1 = Enable the following ranges for the FWH FF50 0000h–FF5F FFFFh FF10 0000h–FF1F FFFFh
0	FWH_40_EN — R/W. Enables decoding two 1M FWH memory ranges. 0 = Disable. 1 = Enable the following ranges for the FWH FF40 0000h–FF4F FFFFh FF00 0000h–FF0F FFFFh

9.1.36 FUNC_DIS—Function Disable Register (LPC I/F—D31:F0)

Offset Address:	F2h	Attribute:	R/W
Default Value:	00h	Size:	16 bits
Lockable:	No	Power Well:	Core

Bit	Description
15	<p>D29_F7_Disable — R/W. Software sets this bit to disable the USB EHCI controller function. BIOS must not enable I/O or memory address space decode, interrupt generation, or any other functionality of functions that are to be disabled.</p> <p>0 = Enable. USB EHCI controller is enabled 1 = Disable. USB EHCI controller is disabled</p>
14	<p>LPC Bridge Disable (D31F0D) — R/W.</p> <p>0 = Enable. 1 = Disable LPC bridge. When disabled, the following spaces will no longer be decoded by the LPC bridge:</p> <ul style="list-style-type: none"> – Device 31, Function 0 Configuration space – Memory cycles below 16 MB (100000h) – I/O cycles below 64 KB (100h) – The Internal I/OxAPIC at FEC0_0000 to FECF_FFFF <p>Memory cycles in the LPC BIOS range below 4GB will still be decoded when this bit is set, but the aliases at the top of 1 MB (the E and F segment) no longer will be decoded.</p>
13:11	Reserved
10	<p>D29_F2_Disable — R/W. Software sets this bit to disable the USB UHCI controller #3 function. BIOS must not enable I/O or memory address space decode, interrupt generation, or any other functionality of functions that are to be disabled.</p> <p>0 = Enable. USB UHCI controller #3 is enabled 1 = Disable. USB UHCI controller #3 is disabled</p>
9	<p>D29_F1_Disable — R/W. Software sets this bit to disable the USB UHCI controller #2 function. BIOS must not enable I/O or memory address space decode, interrupt generation, or any other functionality of functions that are to be disabled.</p> <p>0 = Enable. USB UHCI controller #2 is enabled 1 = Disable. USB UHCI controller #2 is disabled</p>
8	<p>D29_F0_Disable — R/W. Software sets this bit to disable the USB UHCI controller #1 function. BIOS must not enable I/O or memory address space decode, interrupt generation, or any other functionality of functions that are to be disabled.</p> <p>0 = Enable. USB UHCI controller #1 is enabled 1 = Disable. USB UHCI controller #1 is disabled</p>
7	Reserved
6	<p>D31_F6_Disable — R/W. Software sets this bit to disable the AC '97 modem controller function. BIOS must not enable I/O or memory address space decode, interrupt generation, or any other functionality of functions that are to be disabled.</p> <p>0 = Enable. AC '97 Modem is enabled 1 = Disable. AC '97 Modem is disabled</p>
5	<p>D31_F5_Disable — R/W. Software sets this bit to disable the AC '97 audio controller function. BIOS must not enable I/O or memory address space decode, interrupt generation, or any other functionality of functions that are to be disabled.</p> <p>0 = Enable. AC '97 audio controller is enabled 1 = Disable. AC '97 audio controller is disabled</p>
4	Reserved

Bit	Description
3	<p>D31_F3_Disable — R/W. Software sets this bit to disable the SMBus Host controller function. BIOS must not enable I/O or memory address space decode, interrupt generation, or any other functionality of functions that are to be disabled.</p> <p>0 = Enable. SMBus controller is enabled 1 = Disable. SMBus controller is disabled</p>
2	Reserved
1	<p>D31_F1_Disable — R/W. Software sets this bit to disable the IDE controller function. BIOS must not enable I/O or memory address space decode, interrupt generation, or any other functionality of functions that are to be disabled.</p> <p>0 = Enable. IDE controller is enabled 1 = Disable. IDE controller is disabled</p>
0	<p>SMB_FOR_BIOS — R/W. This bit is used in conjunction with bit 3 in this register.</p> <p>0 = No effect. 1 = Allows the SMBus I/O space to be accessible by software when bit 3 in this register is set. The PCI configuration space is hidden in this case. Note that if bit 3 is set alone, the decode of both SMBus PCI configuration and I/O space will be disabled.</p>

NOTES:

1. Software must always disable all functionality within the function before disabling the configuration space.
2. Configuration writes to internal ICH4 USB EHCI (D29:F7) and AC '97 (D31:F5, F6) devices when disabled are illegal and may cause undefined results.

9.2 DMA I/O Registers

Table 9-2. DMA Registers

Port	Alias	Register Name	Default	Type
00h	10h	Channel 0 DMA Base & Current Address Register	Undefined	R/W
01h	11h	Channel 0 DMA Base & Current Count Register	Undefined	R/W
02h	12h	Channel 1 DMA Base & Current Address Register	Undefined	R/W
03h	13h	Channel 1 DMA Base & Current Count Register	Undefined	R/W
04h	14h	Channel 2 DMA Base & Current Address Register	Undefined	R/W
05h	15h	Channel 2 DMA Base & Current Count Register	Undefined	R/W
06h	16h	Channel 3 DMA Base & Current Address Register	Undefined	R/W
07h	17h	Channel 3 DMA Base & Current Count Register	Undefined	R/W
08h	18h	Channel 0–3 DMA Command Register	Undefined	WO
		Channel 0–3 DMA Status Register	Undefined	RO
0Ah	1Ah	Channel 0–3 DMA Write Single Mask Register	000001XXb	WO
0Bh	1Bh	Channel 0–3 DMA Channel Mode Register	000000XXb	WO
0Ch	1Ch	Channel 0–3 DMA Clear Byte Pointer Register	Undefined	WO
0Dh	1Dh	Channel 0–3 DMA Master Clear Register	Undefined	WO
0Eh	1Eh	Channel 0–3 DMA Clear Mask Register	Undefined	WO
0Fh	1Fh	Channel 0–3 DMA Write All Mask Register	0Fh	R/W
80h	90h	Reserved Page Register	Undefined	R/W
81h	91h	Channel 2 DMA Memory Low Page Register	Undefined	R/W
82h	—	Channel 3 DMA Memory Low Page Register	Undefined	R/W
83h	93h	Channel 1 DMA Memory Low Page Register	Undefined	R/W
84h–86h	94h–96h	Reserved Page Registers	Undefined	R/W
87h	97h	Channel 0 DMA Memory Low Page Register	Undefined	R/W
88h	98h	Reserved Page Register	Undefined	R/W
89h	99h	Channel 6 DMA Memory Low Page Register	Undefined	R/W
8Ah	9Ah	Channel 7 DMA Memory Low Page Register	Undefined	R/W
8Bh	9Bh	Channel 5 DMA Memory Low Page Register	Undefined	R/W
8Ch–8Eh	9Ch–9Eh	Reserved Page Registers	Undefined	R/W
8Fh	9Fh	Refresh Low Page Register	Undefined	R/W
C0h	C1h	Channel 4 DMA Base & Current Address Register	Undefined	R/W
C2h	C3h	Channel 4 DMA Base & Current Count Register	Undefined	R/W
C4h	C5h	Channel 5 DMA Base & Current Address Register	Undefined	R/W
C6h	C7h	Channel 5 DMA Base & Current Count Register	Undefined	R/W
C8h	C9h	Channel 6 DMA Base & Current Address Register	Undefined	R/W
CAh	CBh	Channel 6 DMA Base & Current Count Register	Undefined	R/W
CCh	CDh	Channel 7 DMA Base & Current Address Register	Undefined	R/W
CEh	CFh	Channel 7 DMA Base & Current Count Register	Undefined	R/W
D0h	D1h	Channel 4–7 DMA Command Register	Undefined	WO
		Channel 4–7 DMA Status Register	Undefined	RO
D4h	D5h	Channel 4–7 DMA Write Single Mask Register	000001XXb	WO
D6h	D7h	Channel 4–7 DMA Channel Mode Register	000000XXb	WO
D8h	D9h	Channel 4–7 DMA Clear Byte Pointer Register	Undefined	WO
DAh	DBh	Channel 4–7 DMA Master Clear Register	Undefined	WO
DCh	DDh	Channel 4–7 DMA Clear Mask Register	Undefined	WO
DEh	DFh	Channel 4–7 DMA Write All Mask Register	0Fh	R/W

9.2.1 DMABASE_CA—DMA Base and Current Address Registers

I/O Address:	Ch. #0 = 00h; Ch. #1 = 02h Ch. #2 = 04h; Ch. #3 = 06h Ch. #5 = C4h Ch. #6 = C8h Ch. #7 = CCh;	Attribute:	R/W
Default Value:	Undef	Size:	16 bit (per channel), but accessed in two 8-bit quantities
Lockable:	No	Power Well:	Core

Bit	Description
15:0	<p>Base and Current Address — R/W. This register determines the address for the transfers to be performed. The address specified points to two separate registers. On writes, the value is stored in the <i>Base Address</i> register and copied to the <i>Current Address</i> register. On reads, the value is returned from the <i>Current Address</i> register.</p> <p>The address increments/decrements in the Current Address register after each transfer, depending on the mode of the transfer. If the channel is in auto-initialize mode, the Current Address register will be reloaded from the Base Address register after a terminal count is generated.</p> <p>For transfers to/from a 16-bit slave (channel's 5–7), the address is shifted left one bit location. Bit 15 will be shifted into Bit 16.</p> <p>The register is accessed in 8-bit quantities. The byte is pointed to by the current byte pointer flip/flop. Before accessing an address register, the byte pointer flip/flop should be cleared to ensure that the low byte is accessed first</p>

9.2.2 DMABASE_CC—DMA Base and Current Count Registers

I/O Address:	Ch. #0: = 01h; Ch. #1 = 03h Ch. #2: = 05h; Ch. #3 = 07h Ch. #5 = C6h; Ch. #6 = CAh Ch. #7 = CEh;	Attribute:	R/W
Default Value:	Undefined	Size:	16 bit (per channel), but accessed in two 8-bit quantities
Lockable:	No	Power Well:	Core

Bit	Description
15:0	<p>Base and Current Count — R/W. This register determines the number of transfers to be performed. The address specified points to two separate registers. On writes, the value is stored in the <i>Base Count</i> register and copied to the <i>Current Count</i> register. On reads, the value is returned from the <i>Current Count</i> register.</p> <p>The actual number of transfers is one more than the number programmed in the Base Count Register (i.e., programming a count of 4h results in 5 transfers). The count is decrements in the Current Count register after each transfer. When the value in the register rolls from zero to FFFFh, a terminal count is generated. If the channel is in auto-initialize mode, the Current Count register will be reloaded from the Base Count register after a terminal count is generated.</p> <p>For transfers to/from an 8-bit slave (channels 0–3), the count register indicates the number of bytes to be transferred. For transfers to/from a 16-bit slave (channels 57), the count register indicates the number of words to be transferred.</p> <p>The register is accessed in 8-bit quantities. The byte is pointed to by the current byte pointer flip/flop. Before accessing a count register, the byte pointer flip/flop should be cleared to ensure that the low byte is accessed first.</p>

9.2.3 DMAMEM_LP—DMA Memory Low Page Registers

I/O Address:	Ch. #0 = 87h; Ch. #1 = 83h Ch. #2 = 81h; Ch. #3 = 82h Ch. #5 = 8Bh; Ch. #6 = 89h Ch. #7 = 8Ah;	Attribute:	R/W
Default Value:	Undefined	Size:	8 bit
Lockable:	No	Power Well:	Core

Bit	Description
7:0	DMA Low Page (ISA Address bits [23:16]) — R/W. This register works in conjunction with the DMA controller's Current Address Register to define the complete 24-bit address for the DMA channel. This register remains static throughout the DMA transfer. Bit 16 of this register is ignored when in 16-bit I/O count by words mode as it is replaced by the bit 15 shifted out from the current address register.

9.2.4 DMACMD—DMA Command Register

I/O Address:	Ch. #0–3 = 08h; Ch. #4–7 = D0h	Attribute:	WO
Default Value:	Undefined	Size:	8 bit
Lockable:	No	Power Well:	Core

Bit	Description
7:5	Reserved. Must be 0.
4	DMA Group Arbitration Priority — WO. Each channel group is individually assigned either fixed or rotating arbitration priority. At part reset, each group is initialized in fixed priority. 0 = Fixed priority to the channel group 1 = Rotating priority to the group.
3	Reserved. Must be 0
2	DMA Channel Group Enable — WO. Both channel groups are enabled following part reset. 0 = Enable the DMA channel group. 1 = Disable. Disabling channel group 4–7 also disables channel group 0–3, which is cascaded through channel 4.
1:0	Reserved. Must be 0.

9.2.5 DMASTA—DMA Status Register

I/O Address:	Ch. #0–3 = 08h; Ch. #4–7 = D0h	Attribute:	RO
Default Value:	Undefined	Size:	8 bit
Lockable:	No	Power Well:	Core

Bit	Description
7:4	<p>Channel Request Status — RO. When a valid DMA request is pending for a channel, the corresponding bit is set to 1. When a DMA request is not pending for a particular channel, the corresponding bit is set to 0. The source of the DREQ may be hardware or a software request. Note that channel 4 is the cascade channel, so the request status of channel 4 is a logical OR of the request status for channels 0 through 3.</p> <p>4 = Channel 0 5 = Channel 1 (5) 6 = Channel 2 (6) 7 = Channel 3 (7)</p>
3:0	<p>Channel Terminal Count Status — RO. When a channel reaches terminal count (TC), its status bit is set to 1. If TC has not been reached, the status bit is set to 0. Channel 4 is programmed for cascade, so the TC bit response for channel 4 is irrelevant:</p> <p>0 = Channel 0 1 = Channel 1 (5) 2 = Channel 2 (6) 3 = Channel 3 (7)</p>

9.2.6 DMA_WRSMSK—DMA Write Single Mask Register

I/O Address:	Ch. #0–3 = 0Ah; Ch. #4–7 = D4h	Attribute:	WO
Default Value:	0000 01xx	Size:	8 bit
Lockable:	No	Power Well:	Core

Bit	Description
7:3	Reserved. Must be 0.
2	<p>Channel Mask Select — WO.</p> <p>0 = Enable DREQ for the selected channel. The channel is selected through bits [1:0]. Therefore, only one channel can be masked / unmasked at a time. 1 = Disable DREQ for the selected channel.</p>
1:0	<p>DMA Channel Select — WO. These bits select the DMA Channel Mode Register to program.</p> <p>00 = Channel 0 (4) 01 = Channel 1 (5) 10 = Channel 2 (6) 11 = Channel 3 (7)</p>

9.2.7 DMACH_MODE—DMA Channel Mode Register

I/O Address:	Ch. #0–3 = 0Bh; Ch. #4–7 = D6h	Attribute:	WO
Default Value:	0000 00xx	Size:	8 bit
Lockable:	No	Power Well:	Core

Bit	Description
7:6	DMA Transfer Mode — WO. Each DMA channel can be programmed in one of four different modes: 00 = Demand mode 01 = Single mode 10 = Reserved 11 = Cascade mode
5	Address Increment/Decrement Select — WO. This bit controls address increment/decrement during DMA transfers. 0 = Address increment. (default after part reset or Master Clear) 1 = Address decrement.
4	Autoinitialize Enable — WO. 0 = Autoinitialize feature is disabled and DMA transfers terminate on a terminal count. A part reset or Master Clear disables autoinitialization. 1 = DMA restores the Base Address and Count registers to the current registers following a terminal count (TC).
3:2	DMA Transfer Type — WO. These bits represent the direction of the DMA transfer. When the channel is programmed for cascade mode, (bits[7:6] = 11) the transfer type is irrelevant. 00 = Verify: No I/O or memory strobes generated 01 = Write: Data transferred from the I/O devices to memory 10 = Read: Data transferred from memory to the I/O device 11 = Illegal
1:0	DMA Channel Select — WO. These bits select the DMA Channel Mode Register that will be written by bits [7:2]. 00 = Channel 0 (4) 01 = Channel 1 (5) 10 = Channel 2 (6) 11 = Channel 3 (7)

9.2.8 DMA Clear Byte Pointer Register

I/O Address:	Ch. #0–3 = 0Ch; Ch. #4–7 = D8h	Attribute:	WO
Default Value:	xxxx xxxx	Size:	8 bit
Lockable:	No	Power Well:	Core

Bit	Description
7:0	Clear Byte Pointer — WO. No specific pattern. Command enabled with a write to the I/O port address. Writing to this register initializes the byte pointer flip/flop to a known state. It clears the internal latch used to address the upper or lower byte of the 16-bit Address and Word Count Registers. The latch is also cleared by part reset and by the Master Clear command. This command precedes the first access to a 16-bit DMA controller register. The first access to a 16-bit register will then access the significant byte, and the second access automatically accesses the most significant byte.

9.2.9 DMA Master Clear Register

I/O Address: Ch. #0–3 = 0Dh;
Ch. #4–7 = DAh Attribute: WO
Default Value: xxxx xxxx Size: 8 bit

Bit	Description
7:0	Master Clear — WO. No specific pattern. Enabled with a write to the port. This has the same effect as the hardware Reset. The Command, Status, Request, and Byte Pointer flip/flop registers are cleared and the Mask Register is set.

9.2.10 DMA_CLMSK—DMA Clear Mask Register

I/O Address: Ch. #0–3 = 0Eh;
Ch. #4–7 = DCh Attribute: WO
Default Value: xxxx xxxx Size: 8 bit
Lockable: No Power Well: Core

Bit	Description
7:0	Clear Mask Register — WO. No specific pattern. Command enabled with a write to the port.

9.2.11 DMA_WRMSK—DMA Write All Mask Register

I/O Address: Ch. #0–3 = 0Fh;
Ch. #4–7 = DEh Attribute: R/W
Default Value: 0000 1111 Size: 8 bit
Lockable: No Power Well: Core

Bit	Description
7:4	Reserved. Must be 0.
3:0	<p>Channel Mask Bits — R/W. This register permits all four channels to be simultaneously enabled/disabled instead of enabling/disabling each channel individually, as is the case with the Mask Register - Write Single Mask Bit. In addition, this register has a read path to allow the status of the channel mask bits to be read. A channel's mask bit is automatically set to 1 when the Current Byte/Word Count Register reaches terminal count (unless the channel is in auto-initialization mode). Setting the bit(s) to a 1 disables the corresponding DREQ(s). Setting the bit(s) to a 0 enables the corresponding DREQ(s). Bits [3:0] are set to 1 upon part reset or Master Clear. When read, bits [3:0] indicate the DMA channel [3:0] ([7:4]) mask status.</p> <p>Bit 0 = Channel 0 (4) 1 = Masked, 0 = Not Masked Bit 1 = Channel 1 (5) 1 = Masked, 0 = Not Masked Bit 2 = Channel 2 (6) 1 = Masked, 0 = Not Masked Bit 3 = Channel 3 (7) 1 = Masked, 0 = Not Masked</p> <p>NOTE: Disabling channel 4 also disables channels 0–3 due to the cascade of channel's 0–3 through channel 4.</p>

9.3 Timer I/O Registers

Port	Aliases	Register Name/Function	Default Value	Type
40h	50h	Counter 0 Interval Time Status Byte Format	0XXXXXXb	RO
		Counter 0 Counter Access Port Register	Undefined	R/W
41h	51h	Counter 1 Interval Time Status Byte Format	0XXXXXXb	RO
		Counter 1 Counter Access Port Register	Undefined	R/W
42h	52h	Counter 2 Interval Time Status Byte Format	0XXXXXXb	RO
		Counter 2 Counter Access Port Register	Undefined	R/W
43h	53h	Timer Control Word Register	Undefined	WO
		Timer Control Word Register Read Back	XXXXXXX0b	WO
		Counter Latch Command	X0h	WO

9.3.1 TCW—Timer Control Word Register

I/O Address:	43h	Default Value:	All bits undefined
Attribute:	WO	Size:	8 bits

This register is programmed prior to any counter being accessed to specify counter modes. Following part reset, the control words for each register are undefined and each counter output is 0. Each timer must be programmed to bring it into a known state.

Bit	Description
7:6	Counter Select — WO. The Counter Selection bits select the counter the control word acts upon as shown below. The Read Back Command is selected when bits[7:6] are both 1. 00 = Counter 0 select 01 = Counter 1 select 10 = Counter 2 select 11 = Read Back Command
5:4	Read/Write Select — WO. These bits are the read/write control bits. The actual counter programming is done through the counter port (40h for counter 0, 41h for counter 1, and 42h for counter 2). 00 = Counter Latch Command 01 = Read/Write Least Significant Byte (LSB) 10 = Read/Write Most Significant Byte (MSB) 11 = Read/Write LSB then MSB
3:1	Counter Mode Selection — WO. These bits select one of six possible modes of operation for the selected counter. 000 = Mode 0 Out signal on end of count (=0) 001 = Mode 1 Hardware retriggerable one-shot x10 = Mode 2 Rate generator (divide by n counter) x11 = Mode 3 Square wave output 100 = Mode 4 Software triggered strobe 101 = Mode 5 Hardware triggered strobe
0	Binary/BCD Countdown Select — WO. 0 = Binary countdown is used. The largest possible binary count is 2^{16} 1 = Binary coded decimal (BCD) count is used. The largest possible BCD count is 10^4

There are two special commands that can be issued to the counters through this register, the Read Back Command and the Counter Latch Command. When these commands are chosen, several bits within this register are redefined. These register formats are described below.

9.3.1.1 RDBK_CMD—Read Back Command

The Read Back Command is used to determine the count value, programmed mode, and current states of the OUT pin and Null count flag of the selected counter or counters. Status and/or count may be latched in any or all of the counters by selecting the counter during the register write. The count and status remain latched until read, and further latch commands are ignored until the count is read. Both count and status of the selected counters may be latched simultaneously by setting both bit 5 and bit 4 to 0. If both are latched, the first read operation from that counter returns the latched status. The next one or two reads, depending on whether the counter is programmed for one or two byte counts, returns the latched count. Subsequent reads return an unlatched count.

Bit	Description
7:6	Read Back Command. Must be 11 to select the Read Back Command
5	Latch Count of Selected Counters. 0 = Current count value of the selected counters will be latched 1 = Current count will not be latched
4	Latch Status of Selected Counters. 0 = Status of the selected counters will be latched 1 = Status will not be latched
3	Counter 2 Select. 1 = Counter 2 count and/or status will be latched
2	Counter 1 Select. 1 = Counter 1 count and/or status will be latched
1	Counter 0 Select. 1 = Counter 0 count and/or status will be latched.
0	Reserved. Must be 0.

9.3.1.2 LTCH_CMD—Counter Latch Command

The Counter Latch Command latches the current count value. This command is used to insure that the count read from the counter is accurate. The count value is then read from each counter's count register through the Counter Ports Access Ports Register (40h for counter 0, 41h for counter 1, and 42h for counter 2). The count must be read according to the programmed format, i.e. if the counter is programmed for two byte counts, two bytes must be read. The two bytes do not have to be read one right after the other (read, write, or programming operations for other counters may be inserted between the reads). If a counter is latched once and then latched again before the count is read, the second Counter Latch Command is ignored.

Bit	Description
7:6	Counter Selection. These bits select the counter for latching. If 11 is written, then the write is interpreted as a read back command. 00 = Counter 0 01 = Counter 1 10 = Counter 2
5:4	Counter Latch Command. 00 = Selects the Counter Latch Command. Others = Reserved
3:0	Reserved. Must be 0.

9.3.2 SBYTE_FMT—Interval Timer Status Byte Format Register

I/O Address:	Counter 0 = 40h, Counter 1 = 41h, Counter 2 = 42h	Attribute:	RO
Default Value:	Bits[6:0] undefined, Bit 7=0	Size:	8 bits per counter

Each counter's status byte can be read following a Read Back Command. If latch status is chosen (bit 4=0, Read Back Command) as a read back option for a given counter, the next read from the counter's Counter Access Ports Register (40h for counter 0, 41h for counter 1, and 42h for counter 2) returns the status byte. The status byte returns the following:

Bit	Description
7	Counter OUT Pin State — RO. 0 = OUT pin of the counter is also a 0. 1 = OUT pin of the counter is also a 1.
6	Count Register Status — RO. This bit indicates when the last count written to the Count Register (CR) has been loaded into the counting element (CE). The exact time this happens depends on the counter mode, but until the count is loaded into the counting element (CE), the count value will be incorrect. 0 = Count has been transferred from CR to CE and is available for reading. 1 = Null Count. Count has not been transferred from CR to CE and is not yet available for reading.
5:4	Read/Write Selection Status — RO. These reflect the read/write selection made through bits[5:4] of the control register. The binary codes returned during the status read match the codes used to program the counter read/write selection. 00 = Counter Latch Command 01 = Read/Write Least Significant Byte (LSB) 10 = Read/Write Most Significant Byte (MSB) 11 = Read/Write LSB then MSB
3:1	Mode Selection Status — RO. These bits return the counter mode programming. The binary code returned matches the code used to program the counter mode, as listed under the bit function above. 000 = Mode 0Out signal on end of count (=0) 001 = Mode 1Hardware retriggerable one-shot x10 = Mode 2Rate generator (divide by n counter) x11 = Mode 3Square wave output 100 = Mode 4Software triggered strobe 101 = Mode 5Hardware triggered strobe
0	Countdown Type Status — RO. This bit reflects the current countdown type. 0 = Binary countdown 1 = Binary Coded Decimal (BCD) countdown.

9.3.3 Counter Access Ports Register

I/O Address:	Counter 0–40h, Counter 1–41h, Counter 2–42h	Attribute:	R/W
Default Value:	All bits undefined	Size:	8 bit

Bit	Description
7:0	Counter Port — R/W. Each counter port address is used to program the 16-bit Count Register. The order of programming, either LSB only, MSB only, or LSB then MSB, is defined with the Interval Counter Control Register at port 43h. The counter port is also used to read the current count from the Count Register, and return the status of the counter programming following a Read Back Command.

9.4 8259 Interrupt Controller (PIC) Registers

The interrupt controller registers are located at 20h and 21h for the master controller (IRQ0–7), and at A0h and A1h for the slave controller (IRQ8–13). These registers have multiple functions, depending upon the data written to them. Below is a description of the different register possibilities for each address. [Table 9-3](#) provides the register I/O map for the interrupt controller.

Table 9-3. Interrupt Controller I/O Address Map (PIC Registers)

Port	Aliases	Register Name/Function	Default Value	Type
20h	24h, 28h, 2Ch, 30h, 34h, 38h, 3Ch	Master PIC ICW1 Init. Cmd Word 1 Register	Undefined	WO
		Master PIC OCW2 Op Ctrl Word 2 Register	001XXXXXb	WO
		Master PIC OCW3 Op Ctrl Word 3 Register	X01XXX10b	R/W
21h	25h, 29h, 2Dh, 31h, 35h, 39h, 3Dh	Master PIC ICW2 Init. Cmd Word 2 Register	Undefined	WO
		Master PIC ICW3 Init. Cmd Word 3 Register	Undefined	WO
		Master PIC ICW4 Init. Cmd Word 4 Register	01h	WO
		Master PIC OCW1 Op Ctrl Word 1 Register	00h	R/W
A0h	A4h, A8h, ACh, B0h, B4h, B8h, BCh	Slave PIC ICW1 Init. Cmd Word 1 Register	Undefined	WO
		Slave PIC OCW2 Op Ctrl Word 2 Register	001XXXXXb	WO
		Slave PIC OCW3 Op Ctrl Word 3 Register	X01XXX10b	R/W
A1h	A5h, A9h, ADh, B1h, B5h, B9h, BDh	Slave PIC ICW2 Init. Cmd Word 2 Register	Undefined	WO
		Slave PIC ICW3 Init. Cmd Word 3 Register	Undefined	WO
		Slave PIC ICW4 Init. Cmd Word 4 Register	01h	WO
		Slave PIC OCW1 Op Ctrl Word 1 Register	00h	R/W
4D0h	—	Master PIC Edge/Level Triggered Register	00h	R/W
4D1h	—	Slave PIC Edge/Level Triggered Register	00h	R/W

9.4.1 ICW1—Initialization Command Word 1 Register

Offset Address:	Master Controller–020h Slave Controller–0A0h	Attribute:	WO
Default Value:	All bits undefined	Size:	8 bit /controller

A write to Initialization Command Word 1 starts the interrupt controller initialization sequence, during which the following occurs:

1. The Interrupt Mask register is cleared.
2. IRQ7 input is assigned priority 7.
3. The slave mode address is set to 7.
4. Special mask mode is cleared and Status Read is set to IRR.

Once this write occurs, the controller expects writes to ICW2, ICW3, and ICW4 to complete the initialization sequence.

Bit	Description
7:5	ICW/OCW Select — WO. These bits are MCS-85 specific, and not needed. 000 = Should be programmed to 000
4	ICW/OCW Select — WO. 1 = This bit must be a 1 to select ICW1 and enable the ICW2, ICW3, and ICW4 sequence.
3	Edge/Level Bank Select (LTIM) — WO. Disabled. Replaced by the edge/level triggered control registers (ELCR).
2	ADI — WO. 0 = Ignored for the Intel® ICH4. Should be programmed to 0.
1	Single or Cascade (SNGL) — WO. 0 = Must be programmed to a 0 to indicate two controllers operating in cascade mode.
0	ICW4 Write Required (IC4) — WO. 1 = This bit must be programmed to a 1 to indicate that ICW4 needs to be programmed.

9.4.2 ICW2—Initialization Command Word 2 Register

Offset Address: Master Controller—021h Attribute: WO
 Slave Controller—0A1h Size: 8 bit /controller
 Default Value: All bits undefined

ICW2 is used to initialize the interrupt controller with the five most significant bits of the interrupt vector address. The value programmed for bits[7:3] is used by the CPU to define the base address in the interrupt vector table for the interrupt routines associated with each IRQ on the controller. Typical ISA ICW2 values are 08h for the master controller and 70h for the slave controller.

Bit	Description																											
7:3	Interrupt Vector Base Address — WO. Bits [7:3] define the base address in the interrupt vector table for the interrupt routines associated with each interrupt request level input.																											
2:0	<p>Interrupt Request Level — WO. When writing ICW2, these bits should all be 0. During an interrupt acknowledge cycle, these bits are programmed by the interrupt controller with the interrupt to be serviced. This is combined with bits [7:3] to form the interrupt vector driven onto the data bus during the second INTA# cycle. The code is a three bit binary code:</p> <table border="1"> <thead> <tr> <th>Code</th> <th>Master Interrupt</th> <th>Slave Interrupt</th> </tr> </thead> <tbody> <tr> <td>000</td> <td>IRQ0</td> <td>IRQ8</td> </tr> <tr> <td>001</td> <td>IRQ1</td> <td>IRQ9</td> </tr> <tr> <td>010</td> <td>IRQ2</td> <td>IRQ10</td> </tr> <tr> <td>011</td> <td>IRQ3</td> <td>IRQ11</td> </tr> <tr> <td>100</td> <td>IRQ4</td> <td>IRQ12</td> </tr> <tr> <td>101</td> <td>IRQ5</td> <td>IRQ13</td> </tr> <tr> <td>110</td> <td>IRQ6</td> <td>IRQ14</td> </tr> <tr> <td>111</td> <td>IRQ7</td> <td>IRQ15</td> </tr> </tbody> </table>	Code	Master Interrupt	Slave Interrupt	000	IRQ0	IRQ8	001	IRQ1	IRQ9	010	IRQ2	IRQ10	011	IRQ3	IRQ11	100	IRQ4	IRQ12	101	IRQ5	IRQ13	110	IRQ6	IRQ14	111	IRQ7	IRQ15
Code	Master Interrupt	Slave Interrupt																										
000	IRQ0	IRQ8																										
001	IRQ1	IRQ9																										
010	IRQ2	IRQ10																										
011	IRQ3	IRQ11																										
100	IRQ4	IRQ12																										
101	IRQ5	IRQ13																										
110	IRQ6	IRQ14																										
111	IRQ7	IRQ15																										

9.4.3 ICW3—Master Controller Initialization Command Word 3 Register

Offset Address: 21h Attribute: WO
 Default Value: All bits undefined Size: 8 bits

Bit	Description
7:3	0 = These bits must be programmed to zero.
2	<p>Cascaded Interrupt Controller IRQ Connection — WO. This bit indicates that the slave controller is cascaded on IRQ2. When IRQ8#–IRQ15 is asserted, it goes through the slave controller's priority resolver. The slave controller's INTR output onto IRQ2. IRQ2 then goes through the master controller's priority solver. If it wins, the INTR signal is asserted to the CPU, and the returning interrupt acknowledge returns the interrupt vector for the slave controller.</p> <p>1 = This bit must always be programmed to a 1.</p>
1:0	0 = These bits must be programmed to zero.

9.4.4 ICW3—Slave Controller Initialization Command Word 3 Register

Offset Address: A1h Attribute: WO
 Default Value: All bits undefined Size: 8 bits

Bit	Description
7:3	0 = These bits must be programmed to zero.
2:0	Slave Identification Code — WO. These bits are compared against the slave identification code broadcast by the master controller from the trailing edge of the first internal INTA# pulse to the trailing edge of the second internal INTA# pulse. These bits must be programmed to 02h to match the code broadcast by the master controller. When 02h is broadcast by the master controller during the INTA# sequence, the slave controller assumes responsibility for broadcasting the interrupt vector.

9.4.5 ICW4—Initialization Command Word 4 Register

Offset Address: Master Controller–021h Attribute: WO
 Slave Controller–0A1h Size: 8 bits

Bit	Description
7:5	0 = These bits must be programmed to zero.
4	Special Fully Nested Mode (SFNM) — WO. 0 = Should normally be disabled by writing a 0 to this bit. 1 = Special fully nested mode is programmed.
3	Buffered Mode (BUF) — WO. 0 = Must be programmed to 0 for the Intel® ICH4. This is non-buffered mode.
2	Master/Slave in Buffered Mode — WO. Not used. 0 = Should always be programmed to 0.
1	Automatic End of Interrupt (AEOI) — WO. 0 = This bit should normally be programmed to 0. This is the normal end of interrupt. 1 = Automatic End of Interrupt (AEOI) mode is programmed.
0	Microprocessor Mode — WO. 1 = Must be programmed to 1 to indicate that the controller is operating in an Intel Architecture-based system.

9.4.6 OCW1—Operational Control Word 1 (Interrupt Mask) Register

Offset Address: Master Controller–021h Attribute: R/W
 Slave Controller–0A1h Size: 8 bits
 Default Value: 00h

Bit	Description
7:0	Interrupt Request Mask — R/W. When a 1 is written to any bit in this register, the corresponding IRQ line is masked. When a 0 is written to any bit in this register, the corresponding IRQ mask bit is cleared, and interrupt requests will again be accepted by the controller. Masking IRQ2 on the master controller will also mask the interrupt requests from the slave controller.

9.4.7 OCW2—Operational Control Word 2 Register

Offset Address: Master Controller–020h Attribute: WO
 Slave Controller–0A0h Size: 8 bits
 Default Value: Bit[4:0]=undefined, Bit[7:5]=001

Following a part reset or ICW initialization, the controller enters the fully nested mode of operation. Non-specific EOI without rotation is the default. Both rotation mode and specific EOI mode are disabled following initialization.

Bit	Description																				
7:5	<p>Rotate and EOI Codes (R, SL, EOI) — WO. These three bits control the Rotate and End of Interrupt modes and combinations of the two.</p> <p>000 = Rotate in Auto EOI Mode (Clear) 001 = Non-specific EOI command 010 = No Operation 011 = Specific EOI Command 100 = Rotate in Auto EOI Mode (Set) 101 = Rotate on Non-Specific EOI Command 110 = *Set Priority Command 111 = *Rotate on Specific EOI Command *L0–L2 Are Used</p>																				
4:3	<p>OCW2 Select — WO. When selecting OCW2, bits 4:3 = 00</p>																				
2:0	<p>Interrupt Level Select (L2, L1, L0) — WO. L2, L1, and L0 determine the interrupt level acted upon when the SL bit is active. A simple binary code, outlined below, selects the channel for the command to act upon. When the SL bit is inactive, these bits do not have a defined function; programming L2, L1 and L0 to 0 is sufficient in this case.</p> <table border="1"> <thead> <tr> <th>Bits</th> <th>Interrupt Level</th> <th>Bits</th> <th>Interrupt Level</th> </tr> </thead> <tbody> <tr> <td>000</td> <td>IRQ0/8</td> <td>100</td> <td>IRQ4/12</td> </tr> <tr> <td>001</td> <td>IRQ1/9</td> <td>101</td> <td>IRQ5/13</td> </tr> <tr> <td>010</td> <td>IRQ2/10</td> <td>110</td> <td>IRQ6/14</td> </tr> <tr> <td>011</td> <td>IRQ3/11</td> <td>111</td> <td>IRQ7/15</td> </tr> </tbody> </table>	Bits	Interrupt Level	Bits	Interrupt Level	000	IRQ0/8	100	IRQ4/12	001	IRQ1/9	101	IRQ5/13	010	IRQ2/10	110	IRQ6/14	011	IRQ3/11	111	IRQ7/15
Bits	Interrupt Level	Bits	Interrupt Level																		
000	IRQ0/8	100	IRQ4/12																		
001	IRQ1/9	101	IRQ5/13																		
010	IRQ2/10	110	IRQ6/14																		
011	IRQ3/11	111	IRQ7/15																		

9.4.8 OCW3—Operational Control Word 3 Register

Offset Address: Master Controller–020h Attribute: WO
 Slave Controller–0A0h Size: 8 bits
 Default Value: Bit[6,0]=0, Bit[7,4:2]=undefined,
 Bit[5,1]=1

Bit	Description
7	Reserved. Must be 0.
6	<p>Special Mask Mode (SMM) — WO.</p> <p>1 = The Special Mask Mode can be used by an interrupt service routine to dynamically alter the system priority structure while the routine is executing, through selective enabling/disabling of the other channel's mask bits. Bit 5, the ESMM bit, must be set for this bit to have any meaning.</p>
5	<p>Enable Special Mask Mode (ESMM) — WO.</p> <p>0 = Disable. The SMM bit becomes a "don't care". 1 = Enable the SMM bit to set or reset the Special Mask Mode.</p>

Bit	Description
4:3	OCW3 Select — WO. When selecting OCW3, bits 4:3 = 01
2	Poll Mode Command — WO. 0 = Disable. Poll Command is not issued. 1 = Enable. The next I/O read to the interrupt controller is treated as an interrupt acknowledge cycle. An encoded byte is driven onto the data bus, representing the highest priority level requesting service.
1:0	Register Read Command — WO. These bits provide control for reading the In-Service Register (ISR) and the Interrupt Request Register (IRR). When bit 1=0, bit 0 will not affect the register read selection. When bit 1=1, bit 0 selects the register status returned following an OCW3 read. If bit 0=0, the IRR will be read. If bit 0=1, the ISR will be read. Following ICW initialization, the default OCW3 port address read will be "read IRR". To retain the current selection (read ISR or read IRR), always write a 0 to bit 1 when programming this register. The selected register can be read repeatedly without reprogramming OCW3. To select a new status register, OCW3 must be reprogrammed prior to attempting the read. 00 = No Action 01 = No Action 10 = Read IRQ Register 11 = Read IS Register

9.4.9 ELCR1—Master Controller Edge/Level Triggered Register

Offset Address:	4D0h	Attribute:	R/W
Default Value:	00h	Size:	8 bits

In edge mode, (bit[x] = 0), the interrupt is recognized by a low to high transition. In level mode (bit[x] = 1), the interrupt is recognized by a high level. The cascade channel, IRQ2, the heart beat timer (IRQ0), and the keyboard controller (IRQ1), cannot be put into level mode.

Bit	Description
7	IRQ7 ECL — R/W. 0 = Edge. 1 = Level.
6	IRQ6 ECL — R/W. 0 = Edge. 1 = Level.
5	IRQ5 ECL — R/W. 0 = Edge. 1 = Level.
4	IRQ4 ECL — R/W. 0 = Edge. 1 = Level.
3	IRQ3 ECL — R/W. 0 = Edge. 1 = Level.
2:0	Reserved. Must be 0.

9.4.10 ELCR2—Slave Controller Edge/Level Triggered Register

Offset Address: 4D1h Attribute: R/W
 Default Value: 00h Size: 8 bits

In edge mode, (bit[x] = 0), the interrupt is recognized by a low to high transition. In level mode (bit[x] = 1), the interrupt is recognized by a high level. The real time clock, IRQ8#, and the floating point error interrupt, IRQ13, cannot be programmed for level mode.

Bit	Description
7	IRQ15 ECL — R/W. 0 = Edge. 1 = Level.
6	IRQ14 ECL — R/W. 0 = Edge. 1 = Level.
5	Reserved. Must be 0.
4	IRQ12 ECL — R/W. 0 = Edge. 1 = Level.
3	IRQ11 ECL — R/W. 0 = Edge. 1 = Level.
2	IRQ10 ECL — R/W. 0 = Edge. 1 = Level.
1	IRQ9 ECL — R/W. 0 = Edge. 1 = Level.
0	Reserved. Must be 0.

9.5 Advanced Interrupt Controller (APIC)

9.5.1 APIC Register Map

The APIC is accessed via an indirect addressing scheme. Two registers are visible by software for manipulation of most of the APIC registers. These registers are mapped into memory space. The registers are shown in [Table 9-4](#).

Table 9-4. APIC Direct Registers

Address	Register Name	Size	Type
FECO_0000h	Index Register	8 bits	R/W
FECO_0010h	Data Register	32 bits	R/W
FECO_0020h	IRQ Pin Assertion Register	8 bits	WO
FECO_0040h	EOI Register	8 bits	WO

[Table 9-5](#) lists the registers which can be accessed within the APIC via the Index Register. When accessing these registers, accesses must be done a DWORD at a time. For example, software should never access byte 2 from the Data register before accessing bytes 0 and 1. The hardware will not attempt to recover from a bad programming model in this case.

Table 9-5. APIC Indirect Registers

Index	Register Name	Size	Type
00h	ID	32 bits	R/W
01h	Version	32 bits	RO
02h	Arbitration ID	32 bits	RO
03h	Boot Configuration	32 bits	R/W
03–0Fh	Reserved		RO
10–11h	Redirection Table 0	64 bits	R/W, RO
12–13h	Redirection Table 1	64 bits	R/W, RO
...
3E–3Fh	Redirection Table 23	64 bits	R/W, RO
40–FFh	Reserved		RO

9.5.2 IND—Index Register

Memory Address FEC0_0000h Attribute: R/W
 Default Value: 00h Size: 8 bits

The Index Register will select which APIC indirect register to be manipulated by software. The selector values for the indirect registers are listed in [Table 9-5](#). Software will program this register to select the desired APIC internal register

Bit	Description
7:0	APIC Index — R/W. This is an 8-bit pointer into the I/O APIC register table.

9.5.3 DAT—Data Register

Memory Address FEC0_0010h Attribute: R/W
 Default Value: 00000000h Size: 32 bits

This is a 32-bit register specifying the data to be read or written to the register pointed to by the Index register. This register can only be accessed in DWORD quantities.

Bit	Description
7:0	APIC Data — R/W. This is a 32-bit register for the data to be read or written to the APIC indirect register pointed to by the Index register.

9.5.4 IRQPA—IRQ Pin Assertion Register

Memory Address FEC0_0020h Attribute: WO
 Default Value: N/A Size: 32 bits

The IRQ Pin Assertion Register is present to provide a mechanism to scale the number of interrupt inputs into the I/O APIC without increasing the number of dedicated input pins. When a device that supports this interrupt assertion protocol requires interrupt service, that device will issue a write to this register. Bits 4:0 written to this register contain the IRQ number for this interrupt. The only valid values are 0–23. Bits 31:5 are ignored. To provide for future expansion, peripherals should always write a value of 0 for Bits 31:5.

See [Section 5.8.4](#) for more details on how PCI devices will use this field.

Note: Writes to this register are only allowed by the processor and by masters on the ICH4's PCI bus. Writes by devices on PCI buses above the ICH4 (e.g., a PCI segment on a P64H) are not supported.

Bit	Description
31:5	Reserved. To provide for future expansion, the CPU should always write a value of 0 to Bits 31:5.
4:0	IRQ Number — WO. Bits 4:0 written to this register contain the IRQ number for this interrupt. The only valid values are 0–23.

9.5.5 EOIR—EOI Register

Memory Address	FEC0_0040h	Attribute:	WO
Default Value:	N/A	Size:	32 bits

The EOI register is present to provide a mechanism to maintain the level triggered semantics for level-triggered interrupts issued on the parallel bus.

When a write is issued to this register, the I/O APIC will check the lower 8 bits written to this register, and compare it with the vector field for each entry in the I/O Redirection Table. When a match is found, the Remote_IRR bit for that I/O Redirection Entry will be cleared.

Note: This is similar to what already occurs when the APIC sees the EIO message on the serial bus. Note that if multiple I/O Redirection entries, for any reason, assign the same vector for more than one interrupt input, each of those entries will have the Remote_IRR bit reset to 0. The interrupt which was prematurely reset will not be lost because if its input remained active when the Remote_IRR bit is cleared, the interrupt will be reissued and serviced at a later time. Note: Only bits 7:0 are actually used. Bits 31:8 are ignored by the ICH4.

Note: To provide for future expansion, the CPU should always write a value of 0 to Bits 31:8.

Bit	Description
31:8	Reserved. To provide for future expansion, the processor should always write a value of 0 to Bits 31:8.
7:0	Redirection Entry Clear — WO. When a write is issued to this register, the I/O APIC will check this field, and compare it with the vector field for each entry in the I/O Redirection Table. When a match is found, the Remote_IRR bit for that I/O Redirection Entry will be cleared.

9.5.6 ID—Identification Register

Index Offset:	00h	Attribute:	R/W
Default Value:	00000000h	Size:	32 bits

The APIC ID serves as a physical name of the APIC. The APIC bus arbitration ID for the APIC is derived from its I/O APIC ID. This register is reset to zero on power up reset

Bit	Description
31:28	Reserved
27:24	APIC ID — R/W. Software must program this value before using the APIC.
23:16	Reserved
15	Scratchpad bit.
14:0	Reserved

9.5.7 VER—Version Register

Index Offset:	01h	Attribute:	RO
Default Value:	00170002h	Size:	32 bits

Each I/O APIC contains a hardwired Version Register that identifies different implementation of APIC and their versions. The maximum redirection entry information also is in this register, to let software know how many interrupt are supported by this APIC.

Bit	Description
31:24	Reserved
23:16	Maximum Redirection Entries — RO. This is the entry number (0 being the lowest entry) of the highest entry in the redirection table. It is equal to the number of interrupt input pins minus one and is in the range 0 through 239. In the Intel [®] ICH4 this field is hardwired to 17h to indicate 24 interrupts.
15	PRQ — RO. This bit is set to 1 to indicate that this version of the I/O APIC implements the IRQ Assertion register and allows PCI devices to write to it to cause interrupts.
14:8	Reserved
7:0	Version — RO. This is a version number that identifies the implementation version.

9.5.8 ARBID—Arbitration ID Register

Index Offset:	02h	Attribute:	RO
Default Value:	00000000h	Size:	32 bits

This register contains the bus arbitration priority for the APIC. If APIC Clock is running, this register is loaded whenever the APIC ID register is loaded. A rotating priority scheme is used for APIC bus arbitration. The winner of the arbitration becomes the lowest priority agent and assumes an arbitration ID of 0.

Bit	Description
31:28	Reserved
27:24	I/O APIC Identification — RO. This 4-bit field contains the I/O APIC Arbitration ID.
23:0	Reserved

9.5.9 BOOT_CONFIG—Boot Configuration Register

Index Offset:	03h	Attribute:	R/W
Default Value:	00000000h	Size:	32 bits

This register is used to control the interrupt delivery mechanism for the APIC.

Bit	Description
31:1	Reserved
0	Delivery Type (DT) — R/W. 0 = Interrupt delivery mechanism is via the APIC serial bus (default). 1 = Interrupt delivery mechanism is a Processor System Bus message.

9.5.10 Redirection Table

Index Offset:	10h–11h (vector 0) through 3E–3Fh (vector 23)	Attribute:	R/W, RO
Default Value:	Bit 16=1, Bits[15:12]=0. All other bits undefined	Size:	64 bits each, (accessed as two 32 bit quantities)

The Redirection Table has a dedicated entry for each interrupt input pin. The information in the Redirection Table is used to translate the interrupt manifestation on the corresponding interrupt pin into an APIC message.

The APIC will respond to an edge triggered interrupt as long as the interrupt is held until after the acknowledge cycle has begun. Once the interrupt is detected, a delivery status bit internally to the I/O APIC is set. The state machine will step ahead and wait for an acknowledgment from the APIC bus unit that the interrupt message was sent over the APIC bus. Only then will the I/O APIC be able to recognize a new edge on that interrupt pin. That new edge will only result in a new invocation of the handler if its acceptance by the destination APIC causes the Interrupt Request Register bit to go from 0 to 1. (In other words, if the interrupt was not already pending at the destination.)

Bit	Description
63:56	Destination — R/W. If bit 11 of this entry is 0 [Physical], then bits [59:56] specifies an APIC ID. In this case, bits 63:59 should be programmed by software to 0. If bit 11 of this entry is 1 [Logical], then bits [63:56] specify the logical destination address of a set of processors.
55:48	Extended Destination ID (EDID) . These bits are only sent to a local APIC when in Processor System Bus mode. They become bits [11:4] of the address.
47:17	Reserved
16	Mask — R/W. 0 = Not masked: An edge or level on this interrupt pin results in the delivery of the interrupt to the destination. 1 = Masked: Interrupts are not delivered nor held pending. Setting this bit after the interrupt is accepted by a local APIC has no effect on that interrupt. This behavior is identical to the device withdrawing the interrupt before it is posted to the processor. It is software's responsibility to deal with the case where the mask bit is set after the interrupt message has been accepted by a local APIC unit but before the interrupt is dispensed to the processor.
15	Trigger Mode — R/W. This field indicates the type of signal on the interrupt pin that triggers an interrupt. 0 = Edge triggered. 1 = Level triggered.
14	Remote IRR — R/W. This bit is used for level-triggered interrupts; its meaning is undefined for edge-triggered interrupts. 0 = Reset when an EOI message is received from a local APIC. 1 = Set when Local APIC/s accept the level interrupt sent by the I/O APIC.
13	Interrupt Input Pin Polarity — R/W. This bit specifies the polarity of each interrupt signal connected to the interrupt pins. 0 = Active high. 1 = Active low.

Bit	Description
12	Delivery Status — RO. This field contains the current status of the delivery of this interrupt. Writes to this bit have no effect. 0 = Idle. No activity for this interrupt. 1 = Pending. Interrupt has been injected, but delivery is held up due to the APIC bus being busy or the inability of the receiving APIC unit to accept the interrupt at this time.
11	Destination Mode — R/W. This field determines the interpretation of the Destination field. 0 = Physical. Destination APIC ID is identified by bits [59:56]. 1 = Logical. Destinations are identified by matching bit [63:56] with the Logical Destination in the Destination Format Register and Logical Destination Register in each Local APIC.
10:8	Delivery Mode — R/W. This field specifies how the APICs listed in the destination field should act upon reception of this signal. Certain Delivery Modes will only operate as intended when used in conjunction with a specific trigger mode. These encodings are listed in the note below:
7:0	Vector — R/W. This field contains the interrupt vector for this interrupt. Values range between 10h and FEh.

NOTE: Delivery Mode Encoding (Bits 10:8):

- 000 = Fixed. Deliver the signal on the INTR signal of all processor cores listed in the destination. Trigger Mode can be edge or level.
- 001 = Lowest Priority. Deliver the signal on the INTR signal of the processor core that is executing at the lowest priority among all the processors listed in the specified destination. Trigger Mode can be edge or level.
- 010 = SMI (System Management Interrupt). Requires the interrupt to be programmed as edge triggered. The vector information is ignored but must be programmed to all zeroes for future compatibility. Not supported
- 011 = Reserved
- 100 = NMI. Deliver the signal on the NMI signal of all processor cores listed in the destination. Vector information is ignored. NMI is treated as an edge triggered interrupt even if it is programmed as level triggered. For proper operation this redirection table entry must be programmed to edge triggered. The NMI delivery mode does not set the RIRR bit. Once the interrupt is detected, it will be sent over the APIC bus. If the redirection table is incorrectly set to level, the loop count will continue counting through the redirection table addresses. Once the count for the NMI pin is reached again, the interrupt will be sent over the APIC bus again. Not supported
- 101 = INIT. Deliver the signal to all processor cores listed in the destination by asserting the INIT signal. All addressed local APICs will assume their INIT state. INIT is always treated as an edge triggered interrupt even if programmed as level triggered. For proper operation this redirection table entry must be programmed to edge triggered. The INIT delivery mode does not set the RIRR bit. Once the interrupt is detected, it will be sent over the APIC bus. If the redirection table is incorrectly set to level, the loop count will continue counting through the redirection table addresses. Once the count for the INIT pin is reached again, the interrupt will be sent over the APIC bus again. Not supported
- 110 = Reserved
- 111 = ExtINT. Deliver the signal to the INTR signal of all processor cores listed in the destination as an interrupt that originated in an externally connected 8259A compatible interrupt controller. The INTA cycle that corresponds to this ExtINT delivery will be routed to the external controller that is expected to supply the vector. Requires the interrupt to be programmed as edge triggered.

9.6 Real Time Clock Registers

9.6.1 I/O Register Address Map

The RTC internal registers and RAM are organized as two banks of 128 bytes each, called the standard and extended banks. The first 14 bytes of the standard bank contain the RTC time and date information along with four registers, A–D, that are used for configuration of the RTC. The extended bank contains a full 128 bytes of battery backed SRAM, and will be accessible even when the RTC module is disabled (via the RTC configuration register). Registers A–D do not physically exist in the RAM.

All data movement between the host processor and the real-time clock is done through registers mapped to the standard I/O space. The register map appears in [Table 9-6](#).

Table 9-6. RTC I/O Registers

I/O Locations	If U128E bit = 0	Function
70h and 74h	Also alias to 72h and 76h	Real-Time Clock (Standard RAM) Index Register
71h and 75h	Also alias to 73h and 77h	Real-Time Clock (Standard RAM) Target Register
72h and 76h		Extended RAM Index Register (if enabled)
73h and 77h		Extended RAM Target Register (if enabled)

NOTES:

1. I/O locations 70h and 71h are the standard ISA location for the real-time clock. The map for this bank is shown in [Table 9-7](#). Locations 72h and 73h are for accessing the extended RAM. The extended RAM bank is also accessed using an indexed scheme. I/O address 72h is used as the address pointer and I/O address 73h is used as the data register. Index addresses above 127h are not valid. If the extended RAM is not needed, it may be disabled.
2. Software must preserve the value of bit 7 at I/O addresses 70h and 74h. When writing to these addresses, software must first read the value, and then write the same value for bit 7 during the sequential address write.
3. Accesses to 70h, 72h, 74h, and 76h do affect the NMI mask (bit 7 of 70h).

9.6.2 Indexed Registers

The RTC contains two sets of indexed registers that are accessed using the two separate Index and Target registers (70/71h or 72/73h), as shown in [Table 9-7](#).

Table 9-7. RTC (Standard) RAM Bank

Index	Name
00h	Seconds
01h	Seconds Alarm.
02h	Minutes
03h	Minutes Alarm
04h	Hours
05h	Hours Alarm
06h	Day of Week
07h	Day of Month
08h	Month
09h	Year
0Ah	Register A
0Bh	Register B
0Ch	Register C
0Dh	Register D
0Eh–7Fh	114 Bytes of User RAM

9.6.2.1 RTC_REGA—Register A

RTC Index:	0A	Attribute:	R/W
Default Value:	Undefined	Size:	8 bit
Lockable:	No	Power Well:	RTC

This register is used for general configuration of the RTC functions. None of the bits are affected by RSMRST# or any other ICH4 reset signal.

Bit	Description
7	<p>Update In Progress (UIP) — R/W. This bit may be monitored as a status flag.</p> <p>0 = The update cycle will not start for at least 492 μs. The time, calendar, and alarm information in RAM is always available when the UIP bit is 0.</p> <p>1 = The update is soon to occur or is in progress.</p>
6:4	<p>Division Chain Select (DV[2:0]) — R/W. These three bits control the divider chain for the oscillator, and are not affected by RSMRST# or any other reset signal. DV[2] corresponds to bit 6.</p> <p>010 = Normal Operation</p> <p>11X = Divider Reset</p> <p>101 = Bypass 15 stages (test mode only)</p> <p>100 = Bypass 10 stages (test mode only)</p> <p>011 = Bypass 5 stages (test mode only)</p> <p>001 = Invalid</p> <p>000 = Invalid</p>
3:0	<p>Rate Select (RS[3:0]) — R/W. Selects one of 13 taps of the 15 stage divider chain. The selected tap can generate a periodic interrupt if the PIE bit is set in Register B. Otherwise this tap will set the PF flag of Register C. If the periodic interrupt is not to be used, these bits should all be set to zero. RS3 corresponds to bit 3.</p> <p>0000 = Interrupt never toggles</p> <p>0001 = 3.90625 ms</p> <p>0010 = 7.8125 ms</p> <p>0011 = 122.070 μs</p> <p>0100 = 244.141 μs</p> <p>0101 = 488.281 μs</p> <p>0110 = 976.5625 μs</p> <p>0111 = 1.953125 ms</p> <p>1000 = 3.90625 ms</p> <p>1001 = 7.8125 ms</p> <p>1010 = 15.625 ms</p> <p>1011 = 31.25 ms</p> <p>1100 = 62.5 ms</p> <p>1101 = 125 ms</p> <p>1110 = 250 ms</p> <p>1111 = 500 ms</p>

9.6.2.2 RTC_REGB—Register B (General Configuration)

RTC Index: 0Bh Attribute: R/W
 Default Value: U0U00UUU (U: Undefined) Size: 8 bit
 Lockable: No Power Well: RTC

Bit	Description
7	<p>Update Cycle Inhibit (SET) — R/W. Enables/Inhibits the update cycles. This bit is not affected by RSMRST# nor any other reset signal.</p> <p>0 = Update cycle occurs normally once each second.</p> <p>1 = A current update cycle will abort and subsequent update cycles will not occur until SET is returned to zero. When set is one, the BIOS may initialize time and calendar bytes safely.</p> <p>NOTE: This bit should be set then cleared by BIOS early in BIOS POST, after each powerup directly after coin-cell batter insertion.</p>
6	<p>Periodic Interrupt Enable (PIE) — R/W. This bit is cleared by RSMRST#, but not on any other reset.</p> <p>0 = Disable.</p> <p>1 = Allows an interrupt to occur with a time base set with the RS bits of register A.</p>
5	<p>Alarm Interrupt Enable (AIE) — R/W. This bit is cleared by RSMRST#, but not on any other reset.</p> <p>0 = Disable.</p> <p>1 = Allows an interrupt to occur when the AF is set by an alarm match from the update cycle. An alarm can occur once a second, one an hour, once a day, or one a month.</p>
4	<p>Update-Ended Interrupt Enable (UIE) — R/W. This bit is cleared by RSMRST#, but not on any other reset.</p> <p>0 = Disable.</p> <p>1 = Allows an interrupt to occur when the update cycle ends.</p>
3	<p>Square Wave Enable (SQWE) — R/W. This bit serves no function in the Intel® ICH4. It is left in this register bank to provide compatibility with the Motorola 146818B. The ICH4 has no SQW pin. This bit is cleared by RSMRST#, but not on any other reset.</p>
2	<p>Data Mode (DM) — R/W. Specifies either binary or BCD data representation. This bit is not affected by RSMRST# nor any other reset signal.</p> <p>0 = BCD</p> <p>1 = Binary</p>
1	<p>Hour Format (HOURFORM) — R/W. Indicates the hour byte format. This bit is not affected by RSMRST# nor any other reset signal.</p> <p>0 = Twelve-hour mode. In twelve-hour mode, the seventh bit represents AM as zero and PM as one.</p> <p>1 = Twenty-four hour mode.</p>
0	<p>Daylight Savings Enable (DSE) — R/W. Triggers two special hour updates per year. The days for the hour adjustment are those specified in United States federal law as of 1987, which is different than previous years. This bit is not affected by RSMRST# nor any other reset signal.</p> <p>0 = Daylight Savings Time updates do not occur.</p> <p>1 = a) Update on the first Sunday in April, where time increments from 1:59:59 AM to 3:00:00 AM. b) Update on the last Sunday in October when the time first reaches 1:59:59 AM, it is changed to 1:00:00 AM. The time must increment normally for at least two update cycles (seconds) previous to these conditions for the time change to occur properly.</p>

9.6.2.3 RTC_REGC—Register C (Flag Register)

RTC Index:	0Ch	Attribute:	RO
Default Value:	00U00000 (U: Undefined)	Size:	8 bit
Lockable:	No	Power Well:	RTC

Writes to Register C have no effect.

Bit	Description
7	Interrupt Request Flag (IRQF) — RO. $IRQF = (PF * PIE) + (AF * AIE) + (UF * UFE)$. This also causes the CH_IRQ_B signal to be asserted. This bit is cleared upon RSMRST# or a read of Register C.
6	Periodic Interrupt Flag (PF) — RO. This bit is cleared upon RSMRST# or a read of Register C. 0 = If no taps are specified via the RS bits in Register A, this flag will not be set. 1 = Periodic interrupt Flag will be 1 whenever the tap specified by the RS bits of register A is 1.
5	Alarm Flag (AF) — RO. 0 = This bit is cleared upon RTCRST# or a read of Register C. 1 = Alarm Flag will be set after all Alarm values match the current time.
4	Update-ended Flag (UF) — RO. 0 = The bit is cleared upon RSMRST# or a read of Register C. 1 = Set immediately following an update cycle for each second.
3:0	Reserved. Will always report 0.

9.6.2.4 RTC_REGD—Register D (Flag Register)

RTC Index:	0Dh	Attribute:	R/W
Default Value:	10UUUUUU (U: Undefined)	Size:	8 bit
Lockable:	No	Power Well:	RTC

Bit	Description
7	Valid RAM and Time Bit (VRT) — R/W. 0 = This bit should always be written as a 0 for write cycle; however, it will return a 1 for read cycles. 1 = This bit is hardwired to 1 in the RTC power well.
6	Reserved. This bit always returns a 0 and should be set to 0 for write cycles.
5:0	Date Alarm — R/W. These bits store the date of month alarm value. If set to 000000b, then a don't care state is assumed. The host must configure the date alarm for these bits to do anything, yet they can be written at any time. If the date alarm is not enabled, these bits will return zeros to mimic the functionality of the Motorola 146818B. These bits are not affected by RESET.

9.7 Processor Interface Registers

9.7.1 NMI_SC—NMI Status and Control Register

I/O Address:	61h	Attribute:	R/W, RO
Default Value:	00h	Size:	8 bit
Lockable:	No	Power Well:	Core

Bit	Description
7	SERR# NMI Source Status (SERR#_NMI_STS) — RO. 1 = PCI agent detected a system error and pulses the PCI SERR# line. This interrupt source is enabled by setting bit 2 to 0. To reset the interrupt, set bit 2 to 1 and then set it to 0. When writing to port 61h, this bit must be 0.
6	IOCHK# NMI Source Status (IOCHK_NMI_STS) — RO. 1 = An ISA agent (via SERIRQ) asserted IOCHK# on the ISA bus. This interrupt source is enabled by setting bit 3 to 0. To reset the interrupt, set bit 3 to 0 and then set it to 1. When writing to port 61h, this bit must be a 0.
5	Timer Counter 2 OUT Status (TMR2_OUT_STS) — RO. This bit reflects the current state of the 8254 counter 2 output. Counter 2 must be programmed following any PCI reset for this bit to have a determinate value. When writing to port 61h, this bit must be a 0.
4	Refresh Cycle Toggle (REF_TOGGLE) — RO. This signal toggles from either 0 to 1 or 1 to 0 at a rate that is equivalent to when refresh cycles would occur. When writing to port 61h, this bit must be a 0.
3	IOCHK# NMI Enable (IOCHK_NMI_EN) — R/W. 0 = Enabled. 1 = Disabled and cleared.
2	PCI SERR# Enable (PCI_SERR_EN) — R/W. 0 = SERR# NMIs are enabled. 1 = SERR# NMIs are disabled and cleared.
1	Speaker Data Enable (SPKR_DAT_EN) — R/W. 0 = SPKR output is a 0. 1 = SPKR output is equivalent to the Counter 2 OUT signal value.
0	Timer Counter 2 Enable (TIM_CNT2_EN) — R/W. 0 = Disable 1 = Enable

9.7.2 NMI_EN—NMI Enable (and Real Time Clock Index) Register

I/O Address:	70h	Attribute:	R/W-Special
Default Value:	80h	Size:	8 bit
Lockable:	No	Power Well:	Core

Note: The RTC Index field is write-only for normal operation. This field can only be read in Alt-Access Mode. Note, however, that this register is aliased to Port 74h (documented in [Table 17-2](#)), and all bits are readable at that address.

Bits	Description
7	NMI Enable (NMI_EN) — R/W. 0 = Enable NMI sources. 1 = Disable All NMI sources.
6:0	Real Time Clock Index Address (RTC_INDXX) — R/W. This data goes to the RTC to select which register or CMOS RAM address is being accessed.

9.7.3 PORT92—Fast A20 and Init Register

I/O Address:	92h	Attribute:	R/W
Default Value:	00h	Size:	8 bit
Lockable:	No	Power Well:	Core

Bit	Description
7:2	Reserved
1	Alternate A20 Gate (ALT_A20_GATE) — R/W. This bit is Or'd with the A20GATE input signal to generate A20M# to the processor. 0 = A20M# signal can potentially go active. 1 = This bit is set when INIT# goes active.
0	INIT_NOW — R/W. When this bit transitions from a 0 to a 1, the Intel® ICH4 will force INIT# active for 16 PCI clocks.

9.7.4 COPROC_ERR—Coprocessor Error Register

I/O Address:	F0h	Attribute:	WO
Default Value:	00h	Size:	8 bits
Lockable:	No	Power Well:	Core

Bits	Description
7:0	COPROC_ERR — WO. Any value written to this register will cause IGNNE# to go active, if FERR# had generated an internal IRQ13. For FERR# to generate an internal IRQ13, the COPROC_ERR_EN bit (Device 31:Function 0, Offset D0, Bit 13) must be 1.

9.7.5 RST_CNT—Reset Control Register

I/O Address:	CF9h	Attribute:	R/W
Default Value:	00h	Size:	8 bit
Lockable:	No	Power Well:	Core

Bit	Description
7:4	Reserved
3	<p>Full Reset (FULL_RST) — R/W. This bit is used to determine the states of SLP_S3#, SLP_S4# and SLP_S5# after a CF9 hard reset (SYS_RST =1 and RST_CPU is set to 1), after PWROK going low (with RSMRST# high), or after two TCO timeouts.</p> <p>0 = Intel® ICH4 will keep SLP_S3#, SLP_S4# and SLP_S5# high.</p> <p>1 = ICH4 will drive SLP_S3#, SLP_S4# and SLP_S5# low for 3–5 seconds.</p>
2	<p>Reset CPU (RST_CPU) — R/W. When this bit transitions from a 0 to a 1, it initiates a hard or soft reset, as determined by the SYS_RST bit (bit 1 of this register).</p>
1	<p>System Reset (SYS_RST) — R/W. This bit is used to determine a hard or soft reset to the processor.</p> <p>0 = When RST_CPU bit goes from 0 to 1, the ICH4 performs a soft reset by activating INIT# for 16 PCI clocks.</p> <p>1 = When RST_CPU bit goes from 0 to 1, the ICH4 performs a hard reset by activating PCIRST# for 1 millisecond. It also resets the resume well bits (except for those noted throughout the EDS). The SLP_S3#, SLP_S4#, and SLP_S5# signals will not go active.</p>
0	Reserved

9.8 Power Management Registers (D31:F0)

The power management registers are distributed within the PCI Device 31: Function 0 space, as well as a separate I/O range. Each register is described below. Unless otherwise indicate, bits are in the main (core) power well.

Bits not explicitly defined in each register are assumed to be reserved. When writing to a reserved bit, the value should always be 0. Software should not attempt to use the value read from a reserved bit, as it may not be consistently 1 or 0.

9.8.1 Power Management PCI Configuration Registers (D31:F0)

Table 9-8 shows a small part of the configuration space for PCI Device 31: Function 0. It includes only those registers dedicated for power management. Some of the registers are only used for Legacy Power management schemes.

Table 9-8. PCI Configuration Map (PM—D31:F0)

Offset	Mnemonic	Register Name	Default	Type
40h–43h	PM_BASE	ACPI Base Address (See Section 9.1.10)	00000001h	R/W
44h	ACPI_CNTL	ACPI Control (See Section 9.1.11)	00h	R/W
A0h	GEN_PMCON_1	General Power Management Configuration 1	0000h	R/W, RO, R/WO, R/WC
A2h	GEN_PMCON_2	General Power Management Configuration 2	0000h	R/WC, R/W
A4h	GEN_PMCON_3	General Power Management Configuration 3	00h	R/W, R/WC
A8h	STPCLK_DEL	Stop Clock Delay Register	0Dh	R/W
B8–BBh	GPI_ROUT	GPI Route Control	00000000h	R/W
C0	TRP_FWD_EN	I/O Monitor Trap Forwarding Enable		
C4–CAhh	MON[n]_TRP_RNG	I/O Monitor[4:7] Trap Range	0000h	R/W
CCh	MON_TRP_MSK	I/O Monitor Trap Range Mask	0000h	R/W

9.8.1.1 GEN_PMCON_1—General PM Configuration 1 Register (PM—D31:F0)

Offset Address:	A0h	Attribute:	R/W, RO, R/WO, R/WC
Default Value:	00h	Size:	16 bit
Lockable:	No	Usage:	ACPI, Legacy
		Power Well:	Core

Bit	Description
15:11	Reserved
10	Reserved
9	PWRBTN_LVL — RO. This read-only bit indicates the current state of the PWRBTN# signal. 0 = Low. 1 = High.
8:7	Reserved
6	64_EN . Software sets this bit to indicate that the processor is an IA_64 processor, not an IA_32 processor. This may be used in various state machines where there are behavioral differences.
5	CPU SLP# Enable (CPUSLP_EN) — R/W. 0 = Disable. 1 = Enables the CPUSLP# signal to go active in the S1 states. This reduces the CPU power. Note that CPUSLP# will go active on entry to S3, S4 and S5 even if this bit is not set.
4	SMI_LOCK — R/W-Once. When this bit is set, writes to the GLB_SMI_EN bit will have no effect. Once the SMI_LOCK bit is set, writes of 0 to SMI_LOCK bit will have no effect (i.e., once set, this bit can only be cleared by PCIRST#).
3:2	Reserved
1:0	Periodic SMI# Rate Select (PER_SMI_SEL) — R/W. Set by software to control the rate the periodic SMI# is generated. 00 = 1 minute 01 = 32 seconds 10 = 16 seconds 11 = 8 seconds

9.8.1.2 GEN_PMCON_2—General PM Configuration 2 Register (PM—D31:F0)

Offset Address:	A2h	Attribute:	R/WC, R/W
Default Value:	00h	Size:	8 bit
Lockable:	No	Usage:	ACPI, Legacy
		Power Well:	Resume

Bit	Description
7	Reserved
6:5	<p>CPU PLL Lock Time (CPLT) — R/W. This field indicates the amount of time that the processor needs to lock its PLLs. This is used where timing t208 applies (see Chapter 17).</p> <p>00 = Minimum lock time of 30.7 μs (Default) 01 = min 61.4 μs, 10 = min 122.8 μs, and 11 = min 245.6 μs.</p>
4	<p>System Reset Status (SRS)— R/WC. Intel[®] ICH4 sets this bit when the SYS_RESET# button is pressed. BIOS is expected to read this bit and clear it if it is set. This bit is also reset by RSMRST# and CF9h resets.</p>
3	<p>CPU Thermal Trip Status (CTS)— R/WC. This bit is set when PCIRST# is inactive and CPUTHRMTRIP# goes active while the system is in an S0 or S1 state. This bit is also reset by RSMRST# and CF9h resets. It is not reset by the shutdown and reboot associated with the CPUTHRMTRIP# event.</p>
2	Reserved
1	<p>CPU Power Failure (CPUPWR_FLR) — R/WC.</p> <p>0 = Software clears this bit by writing a 0 to the bit position. 1 = Indicates that the VRMPWRGD signal from the processor's VRM went low.</p>
0	<p>PWROK Failure (PWROK_FLR) — R/WC.</p> <p>0 = Software clears this bit by writing a 1 to the bit position, or when the system goes into a G3 state. 1 = This bit will be set any time PWROK goes low, when the system was in S0, or S1 state. The bit will be cleared only by software by writing a 1 to this bit or when the system goes to a G3 state.</p> <p>NOTES:</p> <ol style="list-style-type: none"> Traditional designs have a reset button logically AND'd with the PWROK signal from the power supply and the CPU's voltage regulator module. If this is done with the ICH4, the PWROK_FLR bit will be set. The ICH4 treats this internally as if the RSMRST# signal had gone active. However, it is not treated as a full power failure. If PWROK goes inactive and then active (but RSMRST# stays high), then the ICH4 will reboot (regardless of the state of the AFTERG3 bit). If the RSMRST# signal also goes low before PWROK goes high, then this is a full power failure, and the reboot policy is controlled by the AFTERG3 bit. In the case of true PWROK failure, PWROK will go low first before the VRMPWRGD.

NOTE: VRMPWROK is sampled using the RTC clock. Therefore, low times that are less than one RTC clock period may not be detected by the ICH4.

9.8.1.3 GEN_PMCON_3—General PM Configuration 3 Register (PM—D31:F0)

Offset Address:	A4h	Attribute:	R/W, R/WC
Default Value:	00h	Size:	8 bit
Lockable:	No	Usage:	ACPI, Legacy
		Power Well:	RTC

Bit	Description
7:6	<p>SWSMI_RATE_SEL — R/W. This 2-bit value indicates when the SWSMI timer will time out. Valid values are:</p> <p>00 = 1.5 ms ± 0.5 ms</p> <p>01 = 16 ms ± 4 ms</p> <p>10 = 32 ms ± 4 ms</p> <p>11 = 64 ms ± 4 ms</p>
5:3	Reserved
2	<p>RTC Power Status (RTC_PWR_STS) — R/W. This bit is set when RTCRST# is low. The bit is not cleared by any type of reset. When the system boots, BIOS can detect that the FREQ_STRAP register contents are 1111 (the default when RTCRST# has been low). If this bit is also set, then BIOS knows the RTC battery had been removed. In that case, BIOS should take steps to reprogram the FREQ_STRAP register with the correct value, and then reboot the system.</p>
1	<p>Power Failure (PWR_FLR) — R/WC. This bit is in the RTC well, and is not cleared by any type of reset except RTCRST#.</p> <p>0 = Indicates that the trickle current has not failed since the last time the bit was cleared. Software clears this bit by writing a 1 to the bit position.</p> <p>1 = Indicates that the trickle current (from the main battery or trickle supply) was removed or failed.</p> <p>NOTE: Clearing CMOS in an Intel® ICH4-based platform can be done by using a jumper on RTCRST# or GPI, or using SAFEMODE strap. Implementations should not attempt to clear CMOS by using a jumper to pull VccRTC low.</p>
0	<p>AFTERG3_EN — R/W. Determines what state to go to when power is re-applied after a power failure (G3 state). This bit is in the RTC well and is not cleared by any type of reset except writes to CF9h or RTCRST#.</p> <p>0 = System will return to S0 state (boot) after power is re-applied.</p> <p>1 = System will return to the S5 state (except if it was in S4, in which case it will return to S4). In the S5 state, the only enabled wake event is the Power Button or any enabled wake event that was preserved through the power failure.</p>

NOTE: RSMRST# is sampled using the RTC clock. Therefore, low times that are less than one RTC clock period may not be detected by the ICH4.

9.8.1.4 STPCLK_DEL—Stop Clock Delay Register (PM—D31:F0)

Offset Address:	A8h	Attribute:	R/W
Default Value:	0Dh	Size:	8 bit
Power Well:	Core	Usage:	ACPI, Legacy

Bit	Description
7:6	Reserved
5:0	<p>STPCLK_DEL — R/W. This field selects the AC timing value for t190 (CPUSLP# inactive to STPCLK# inactive). The default value of 0Dh yields a default of approximately 50.045 microseconds. The maximum value of 3Fh will result in a time of 245 microseconds.</p> <p>NOTE: Software must program the value to a range that can be tolerated by the associated processor and chipset. The Intel® ICH4 requires that software does not program a value of 00h or 01h; a minimum programming of 02h yields the minimum possible delay of 3.87 μs.</p>

9.8.1.5 GPI_ROUT—GPI Routing Control Register (PM—D31:F0)

Offset Address:	B8h–BBh	Attribute:	R/W
Default Value:	0000h	Size:	32-bit
Lockable:	No	Power Well:	Resume

Bit	Description
31:30	GPI15 Route — R/W. See bits 1:0 for description.
Same pattern for GPI14 through GPI3	
5:4	GPI2 Route — R/W. See bits 1:0 for description.
3:2	GPI1 Route — R/W. See bits 1:0 for description.
1:0	<p>GPI0 Route — R/W. GPIO[15:0] can be routed to cause an SMI or SCI when the GPI[n]_STS bit is set. If the GPIO is not set to an input, this field has no effect.</p> <p>If the system is in an S1–S5 state and if the GPE0_EN bit is also set, then the GPI can cause a Wake event, even if the GPI is NOT routed to cause an SMI# or SCI.</p> <p>00 = No effect. 01 = SMI# (if corresponding ALT_GP_SMI_EN bit is also set) 10 = SCI (if corresponding GPE0_EN bit is also set) 11 = Reserved</p>

NOTE: GPIOs that are not implemented will not have the corresponding bits implemented in this register.

9.8.1.6 TRP_FWD_EN—IO Monitor Trap Forwarding Enable Register (PM—D31:F0)

Offset Address:	C0h	Attribute:	R/W (Special)
Default Value:	00h	Size:	8 bits
Lockable:	No	Usage:	Legacy Only
Power Well:	Core		

The ICH4 uses this register to enable the monitors to forward cycles to LPC, independent of the POS_DEC_EN bit and the bits that enable the monitor to generate an SMI#. The only criteria is that the address passes the decoding logic as determined by the MON[n]_TRP_RNG and MON_TRP_MSK register settings.

Bit	Description
7	MON7_FWD_EN — R/W. 0 = Disable. Cycles trapped by I/O Monitor 7 will not be forwarded to LPC. 1 = Enable. Cycles trapped by I/O Monitor 7 will be forwarded to LPC.
6	MON6_FWD_EN — R/W. 0 = Disable. Cycles trapped by I/O Monitor 6 will not be forwarded to LPC. 1 = Enable. Cycles trapped by I/O Monitor 6 will be forwarded to LPC.
5	MON5_FWD_EN — R/W. 0 = Disable. Cycles trapped by I/O Monitor 5 will not be forwarded to LPC. 1 = Enable. Cycles trapped by I/O Monitor 5 will be forwarded to LPC.
4	MON4_FWD_EN — R/W. 0 = Disable. Cycles trapped by I/O Monitor 4 will not be forwarded to LPC. 1 = Enable. Cycles trapped by I/O Monitor 4 will be forwarded to LPC.
3:0	Reserved

9.8.1.7 MON[n]_TRP_RNG—I/O Monitor [4:7] Trap Range Register for Devices 4–7 (PM—D31:F0)

Offset Address:	C4h, C6h, C8h, CAh	Attribute:	R/W
Default Value:	00h	Size:	16 bits
Lockable:	No	Usage:	Legacy Only
Power Well:	Core		

These registers set the ranges that Device Monitors 4–7 should trap. Offset 4Ch corresponds to Monitor 4. Offset C6h corresponds to Monitor 5, etc.

If the trap is enabled in the MON_SMI register and the address is in the trap range (and passes the mask set in the MON_TRP_MSK register) the ICH4 will generate an SMI#. This SMI# occurs if the address is positively decoded by another device on PCI or by the ICH4 (because it would be forwarded to LPC or some other ICH4 internal registers). The trap ranges should not point to registers in the ICH4's internal IDE, USB, AC '97 or LAN I/O space. If the cycle is to be claimed by the ICH4 and targets one of the permitted ICH4 internal registers (interrupt controller, RTC, etc.), the cycle will complete to the intended target and an SMI# will be generated (this is the same functionality as the ICH component). If the cycle is to be claimed by the ICH4 and the intended target is on LPC, an SMI# will be generated but the cycle will only be forwarded to the intended target if forwarding to LPC is enabled via the TRP_FWD_EN register settings.

Bit	Description
15:0	MON[n]_TRAP_BASE — R/W. Base I/O locations that MON[n] traps (where $n = 4, 5, 6$ or 7). The range can be mapped anywhere in the processor I/O space (0–64 KB). Any access to the range will generate an SMI# if enabled by the associated DEV[n]_TRAP_EN bit in the MON_SMI register (PMBASE +40h).

9.8.1.8 MON_TRP_MSK—I/O Monitor Trap Range Mask Register for Devices 4–7 (PM—D31:F0)

Offset Address:	CCh	Attribute:	R/W
Default Value:	00h	Size:	16 bits
Lockable:	No	Usage:	Legacy Only
Power Well:	Core		

Bit	Description
15:12	MON7_MASK — R/W. Selects low 4-bit mask for the I/O locations that MON7 will trap. Similar to MON4_MASK.
11:8	MON6_MASK — R/W. Selects low 4-bit mask for the I/O locations that MON6 will trap. Similar to MON4_MASK.
7:4	MON5_MASK — R/W. Selects low 4-bit mask for the I/O locations that MON5 will trap. Similar to MON4_MASK.
3:0	MON4_MASK — R/W. Selects low 4-bit mask for the I/O locations that MON7 will trap. When a mask bit is set to a 1, the corresponding bit in the base I/O selection will not be decoded. For example, if MON4_TRAP_BASE = 1230h, and MON4_MSK = 0011b, the Intel® ICH4 will decode 1230h, 1231h, 1232h, and 1233h for Monitor 4.

9.8.2 APM I/O Decode

Table 9-9 shows the I/O registers associated with APM support. This register space is enabled in the PCI Device 31: Function 0 space (APMDEC_EN), and cannot be moved (fixed I/O location).

Table 9-9. APM Register Map

Address	Mnemonic	Register Name	Default	Type
B2h	APM_CNT	Advanced Power Management Control Port	00h	R/W
B3h	APM_STS	Advanced Power Management Status Port	00h	R/W

9.8.2.1 APM_CNT—Advanced Power Management Control Port Register

I/O Address:	B2h	Attribute:	R/W
Default Value:	00h	Size:	8 bit
Lockable:	No	Usage:	Legacy Only
Power Well:	Core		

Bit	Description
7:0	Used to pass an APM command between the OS and the SMI handler. Writes to this port not only store data in the APMC register, but also generates an SMI# when the APMC_EN bit is set.

9.8.2.2 APM_STS—Advanced Power Management Status Port Register

I/O Address:	B3h	Attribute:	R/W
Default Value:	00h	Size:	8 bit
Lockable:	No	Usage:	Legacy Only
Power Well:	Core		

Bit	Description
7:0	Used to pass data between the OS and the SMI handler. Basically, this is a scratchpad register and is not affected by any other register or function (other than a PCI reset).

9.8.3 Power Management I/O Registers

Table 9-10 shows the registers associated with ACPI and Legacy power management support. These registers are enabled in the PCI Device 31: Function 0 space (PM_IO_EN), and can be moved to any I/O location (128-byte aligned). The registers are defined to be compliant with the ACPI 1.0 specification, and use the same bit names.

Note: All reserved bits and registers will always return 0 when read, and will have no effect when written.

Table 9-10. ACPI and Legacy I/O Register Map

PMBASE + Offset	Register Name	ACPI Pointer	Default	Attributes
00–01h	Power Management 1 Status	PM1a_EVT_BLK	0000h	R/WC
02–03h	Power Management 1 Enable	PM1a_EVT_BLK+2	0000h	R/W
04–07h	Power Management 1 Control	PM1a_CNT_BLK	00000000h	R/W, WO
08–0Bh	Power Management 1 Timer	PMTMR_BLK	00000000h	RO
0Ch	Reserved			
10h–13h	Processor Control	P_BLK	00000000h	R/W, RO
14h	Level 2 Register	P_BLK+4	00h	RO
15h–16h	Reserved			
17–1Fh	Reserved			
20h	Reserved			
28–2Bh	General Purpose Event 0 Status	GPE0_BLK	00000000h	R/W, R/WC
2C–2Fh	General Purpose Event 0 Enables	GPE0_BLK+4	00000000h	R/W
30–33h	SMI# Control and Enable		00000000h	R/W, WO, R/W-Special
34–37h	SMI Status Register		00000000h	R/WC, RO
38–39h	Alternate GPI SMI Enable		0000h	R/W
3A–3Bh	Alternate GPI SMI Status		0000h	R/WC
3C–3Fh	Reserved		0000h	RO
40h	Monitor SMI Status		0000h	R/W, R/WC
42h	Reserved			
44h	Device Trap Status		0000h	R/W
48h	Trap Enable register		0000h	R/W
4Ch–4Dh	Bus Address Tracker		Last Cycle	RO
4Eh	Bus Cycle Tracker		Last Cycle	RO
50h	Reserved			
51h–5Fh	Reserved			
60h–7Fh	Reserved for TCO Registers			

9.8.3.1 PM1_STS—Power Management 1 Status Register

I/O Address:	PMBASE + 00h (ACPI PM1a_EVT_BLK)	Attribute:	R/WC
Default Value:	0000h	Size:	16 bit
Lockable:	No	Usage:	ACPI or Legacy
Power Well:	Bits 0–7: Core, Bits 8–10, 12–15: Resume, Bit 11: RTC		

If bit 10 or 8 in this register is set, and the corresponding _EN bit is set in the PM1_EN register, then the ICH4 will generate a Wake Event. Once back in an S0 state (or if already in an S0 state when the event occurs), the ICH4 will also generate an SCI if the SCI_EN bit is set, or an SMI# if the SCI_EN bit is not set.

Note: Bit 5 does not cause an SMI# or a wake event. Bit 0 does not cause a wake event but can cause an SMI# or SCI.

Bit	Description
15	<p>Wake Status (WAK_STS) — R/WC. This bit is not affected by hard resets caused by a CF9 write, but is reset by RSMRST#.</p> <p>0 = Software clears this bit by writing a 1 to the bit position.</p> <p>1 = Set by hardware when the system is in one of the sleep states (via the SLP_EN bit) and an enabled wake event occurs. Upon setting this bit, the Intel® ICH4 will transition the system to the ON state.</p> <p>If the AFTERG3_EN bit is not set and a power failure occurs without the SLP_EN bit set, the system will return to an S0 state when power returns and the WAK_STS bit will not be set.</p> <p>If the AFTERG3_EN bit is set and a power failure occurs without the SLP_EN bit having been set, the system will go into an S5 state when power returns, and a subsequent wake event will cause the WAK_STS bit to be set. Note that any subsequent wake event would have to be caused by either a Power Button press, or an enabled wake event that was preserved through the power failure (enable bit in the RTC well).</p>
14:12	Reserved
11	<p>Power Button Override Status (PRBTNOR_STS) — R/WC. This bit is set any time a Power Button Override occurs (i.e., the power button is pressed for at least 4 consecutive seconds), or due to the corresponding bit in the SMBus slave message. The power button override causes an unconditional transition to the S5 state, as well as sets the AFTERG# bit. The BIOS or SCI handler clears this bit by writing a 1 to it. This bit is not affected by hard resets via CF9h writes, and is not reset by RSMRST#. Thus, this bit is preserved through power failures.</p>
10	<p>RTC Status (RTC_STS) — R/WC. This bit is not affected by hard resets caused by a CF9 write, but is reset by RSMRST#.</p> <p>0 = Software clears this bit by writing a 1 to the bit position.</p> <p>1 = Set by hardware when the RTC generates an alarm (assertion of the IRQ8# signal). Additionally if the RTC_EN bit is set, the setting of the RTC_STS bit will generate a wake event.</p>
9	Reserved

Bit	Description
8	<p>Power Button Status (PWRBTN_STS) — R/WC. This bit is not affected by hard resets caused by a CF9 write.</p> <p>0 = If the PWRBTN# signal is held low for more than 4 seconds, the hardware clears the PWRBTN_STS bit, sets the PWRBTNOR_STS bit, and the system transitions to the S5 state with only PWRBTN# enabled as a wake event.</p> <p>This bit can be cleared by software by writing a one to the bit position.</p> <p>1 = This bit is set by hardware when the PWRBTN# signal is asserted Low, independent of any other enable bit.</p> <p>In the S0 state, while PWRBTN_EN and PWRBTN_STS are both set, an SCI (or SMI# if SCI_EN is not set) will be generated.</p> <p>In any sleeping state S1–S5, while PWRBTN_EN and PWRBTN_STS are both set, a wake event is generated.</p>
7:6	Reserved
5	<p>Global Status (GBL_STS) — R/WC.</p> <p>0 = The SCI handler should then clear this bit by writing a 1 to the bit location.</p> <p>1 = Set when an SCI is generated due to BIOS wanting the attention of the SCI handler. BIOS has a corresponding bit, BIOS_RLS, which will cause an SCI and set this bit.</p>
4	Reserved
3:1	Reserved
0	<p>Timer Overflow Status (TMROF_STS) — R/WC.</p> <p>0 = The SCI or SMI# handler clears this bit by writing a 1 to the bit location.</p> <p>1 = This bit gets set any time bit 22 of the 24-bit timer goes high (bits are numbered from 0 to 23). This will occur every 2.3435 seconds. When the TMROF_EN bit is set, then the setting of the TMROF_STS bit will additionally generate an SCI or SMI# (depending on the SCI_EN).</p>

9.8.3.2 PM1_EN—Power Management 1 Enable Register

I/O Address:	PMBASE + 02h (ACPI PM1a_EVT_BLK + 2)	Attribute:	R/W
Default Value:	0000h	Size:	16 bit
Lockable:	No	Usage:	ACPI or Legacy
Power Well:	Bits 0–7: Core, Bits 8–9, 11–15: Resume Bit 10: RTC		

Bit	Description												
15:11	Reserved												
10	<p>RTC Event Enable (RTC_EN) — R/W. This bit is in the RTC well to allow an RTC event to wake after a power failure. This bit is not cleared by any reset other than RTCRST# or a Power Button Override event.</p> <p>0 = No SCI (or SMI#) or wake event is generated then RTC_STS goes active. 1 = An SCI (or SMI#) or wake event will occur when this bit is set and the RTC_STS bit goes active.</p>												
9	Reserved.												
8	<p>Power Button Enable (PWRBTN_EN) — R/W. This bit is used to enable the setting of the PWRBTN_STS bit to generate a power management event (SMI#, SCI). PWRBTN_EN has no effect on the PWRBTN_STS bit being set by the assertion of the power button. The Power Button is always enabled as a Wake event.</p> <p>0 = Disable. 1 = Enable.</p>												
7:6	Reserved.												
5	<p>Global Enable (GBL_EN) — R/W. When both the GBL_EN and the GBL_STS are set, an SCI is raised.</p> <p>0 = Disable. 1 = Enable SCI on GBL_STS going active.</p>												
4:1	Reserved.												
0	<p>Timer Overflow Interrupt Enable (TMROF_EN) — R/W. Works in conjunction with the SCI_EN bit as described below:</p> <table border="1"> <thead> <tr> <th>TMROF_EN</th> <th>SCI_EN</th> <th>Effect when TMROF_STS is set</th> </tr> </thead> <tbody> <tr> <td>0</td> <td>x</td> <td>No SMI# or SCI</td> </tr> <tr> <td>1</td> <td>0</td> <td>SMI#</td> </tr> <tr> <td>1</td> <td>1</td> <td>SCI</td> </tr> </tbody> </table>	TMROF_EN	SCI_EN	Effect when TMROF_STS is set	0	x	No SMI# or SCI	1	0	SMI#	1	1	SCI
TMROF_EN	SCI_EN	Effect when TMROF_STS is set											
0	x	No SMI# or SCI											
1	0	SMI#											
1	1	SCI											

9.8.3.3 PM1_CNT—Power Management 1 Control Register

I/O Address:	PMBASE + 04h (<i>ACPI PM1a_CNT_BLK</i>)	Attribute:	R/W, WO
Default Value:	0000h	Size:	32-bit
Lockable:	No	Usage:	ACPI or Legacy
Power Well:	Bits 0–7: Core, Bits 8–12: RTC Bits 13–15: Resume		

Bit	Description
15:14	Reserved.
13	Sleep Enable (SLP_EN) — WO. Setting this bit causes the system to sequence into the Sleep state defined by the SLP_TYP field.
12:10	Sleep Type (SLP_TYP) — R/W. This 3-bit field defines the type of Sleep the system should enter when the SLP_EN bit is set to 1. 000 = N: Typically maps to S0 state. 001 = It asserts STPCLK#. Puts CPU in Stop-Grant state. Optional to assert CPUSLP# to put processor in sleep state: Typically maps to S1 state. 010 = Reserved 011 = Reserved 100 = Reserved 101 = Suspend-To-RAM. Assert SLP_S1# and SLP_S3#: Typically maps to S3 state. 110 = Suspend-To-Disk. Assert SLP_S1#, SLP_S3#, and SLP_S4#: Typically maps to S4 state. 111 = Soft Off. Assert SLP_S1#, SLP_S3#, SLP_S4#, and SLP_S5#: Typically maps to S5 state. NOTE: These bits are only reset by RTCRST#.
9:3	Reserved.
2	Global Release (GBL_RLS) — WO. 0 = This bit always reads as 0. 1 = ACPI software writes a 1 to this bit to raise an event to the BIOS. BIOS software has a corresponding enable and status bits to control its ability to receive ACPI events.
1	Reserved
0	SCI Enable (SCI_EN) — R/W. Selects the SCI interrupt or the SMI# interrupt for various events including the bits in the PM1_STS register (bit 10, 8, 0), and bits in GPE0_STS. 0 = These events will generate an SMI#. 1 = These events will generate an SCI.

9.8.3.4 PM1_TMR—Power Management 1 Timer Register

I/O Address:	PMBASE + 08h (<i>ACPI PMTMR_BLK</i>)	Attribute:	RO
Default Value:	xx000000h	Size:	32-bit
Lockable:	No	Usage:	ACPI
Power Well:	Core		

Bit	Description
31:24	Reserved
23:0	<p>Timer Value (TMR_VAL) — RO. Returns the running count of the PM timer. This counter runs off a 3.579545 MHz clock (14.31818 MHz divided by 4). It is reset to zero during a PCI reset, and then continues counting as long as the system is in the S0 state.</p> <p>Anytime bit 22 of the timer goes HIGH to LOW (bits referenced from 0 to 23), the TMROF_STS bit is set. The high-to-low transition will occur every 2.3435 seconds. If the TMROF_EN bit is set, an SCI interrupt is also generated.</p>

9.8.3.5 PROC_CNT—Processor Control Register

I/O Address:	PMBASE + 10h (<i>ACPI P_BLK</i>)	Attribute:	R/W, RO
Default Value:	00000000h	Size:	32 bit
Lockable:	No (bits 7:5 are write once)	Usage:	ACPI or Legacy
Power Well:	Core		

Bit	Description
31:18	Reserved
17	<p>Throttle Status (THTL_STS) — RO.</p> <p>0 = No clock throttling is occurring (maximum processor performance).</p> <p>1 = Indicates that the clock state machine is in some type of low power state (where the processor is not running at its maximum performance): thermal throttling or hardware throttling.</p>
16:9	Reserved
8	<p>Force Thermal Throttling (FORCE_THTL) — R/W. Software can set this bit to force the thermal throttling function. This has the same effect as the THRM# signal being active for 2 seconds.</p> <p>0 = No forced throttling.</p> <p>1 = Throttling at the duty cycle specified in THRM_DTY starts immediately (no 2 second delay), and no SMI# is generated.</p>

Bit	Description																											
7:5	<p>THRM_DTY — R/W. This write-once 3-bit field determines the duty cycle of the throttling when the thermal override condition occurs. The duty cycle indicates the approximate percentage of time the STPCLK# signal is asserted while in the throttle mode. The STPCLK# throttle period is 1024 PCICLKs. Note that the throttling only occurs if the system is in the C0 state. If in the C2 state, no throttling occurs.</p> <p>There is no enable bit for thermal throttling, because it should not be disabled. Once the THRM_DTY field is written, any subsequent writes will have no effect until PCIRST# goes active.</p> <table border="1"> <thead> <tr> <th>THRM_DTY</th> <th>Throttle Mode</th> <th>PCI Clocks</th> </tr> </thead> <tbody> <tr> <td>000</td> <td>50% (Default)</td> <td>512</td> </tr> <tr> <td>001</td> <td>87.5%</td> <td>896</td> </tr> <tr> <td>010</td> <td>75.0%</td> <td>768</td> </tr> <tr> <td>011</td> <td>62.5%</td> <td>640</td> </tr> <tr> <td>100</td> <td>50%</td> <td>512</td> </tr> <tr> <td>101</td> <td>37.5%</td> <td>384</td> </tr> <tr> <td>110</td> <td>25%</td> <td>256</td> </tr> <tr> <td>111</td> <td>12.5%</td> <td>128</td> </tr> </tbody> </table>	THRM_DTY	Throttle Mode	PCI Clocks	000	50% (Default)	512	001	87.5%	896	010	75.0%	768	011	62.5%	640	100	50%	512	101	37.5%	384	110	25%	256	111	12.5%	128
THRM_DTY	Throttle Mode	PCI Clocks																										
000	50% (Default)	512																										
001	87.5%	896																										
010	75.0%	768																										
011	62.5%	640																										
100	50%	512																										
101	37.5%	384																										
110	25%	256																										
111	12.5%	128																										
4	<p>THTL_EN — R/W. When set and the system is in a C0 state, it enables a processor-controlled STPCLK# throttling. The duty cycle is selected in the THTL_DTY field.</p> <p>0 = Disable 1 = Enable</p>																											
3:1	<p>THTL_DTY — R/W. This 3-bit field determines the duty cycle of the throttling when the THTL_EN bit is set. The duty cycle indicates the approximate percentage of time the STPCLK# signal is asserted (low) while in the throttle mode. The STPCLK# throttle period is 1024 PCICLKs.</p> <table border="1"> <thead> <tr> <th>THTL_DTY</th> <th>Throttle Mode</th> <th>PCI Clocks</th> </tr> </thead> <tbody> <tr> <td>000</td> <td>50% (Default)</td> <td>512</td> </tr> <tr> <td>001</td> <td>87.5%</td> <td>896</td> </tr> <tr> <td>010</td> <td>75.0%</td> <td>768</td> </tr> <tr> <td>011</td> <td>62.5%</td> <td>640</td> </tr> <tr> <td>100</td> <td>50%</td> <td>512</td> </tr> <tr> <td>101</td> <td>37.5%</td> <td>384</td> </tr> <tr> <td>110</td> <td>25%</td> <td>256</td> </tr> <tr> <td>111</td> <td>12.5%</td> <td>128</td> </tr> </tbody> </table>	THTL_DTY	Throttle Mode	PCI Clocks	000	50% (Default)	512	001	87.5%	896	010	75.0%	768	011	62.5%	640	100	50%	512	101	37.5%	384	110	25%	256	111	12.5%	128
THTL_DTY	Throttle Mode	PCI Clocks																										
000	50% (Default)	512																										
001	87.5%	896																										
010	75.0%	768																										
011	62.5%	640																										
100	50%	512																										
101	37.5%	384																										
110	25%	256																										
111	12.5%	128																										
0	Reserved																											

9.8.3.6 LV2 — Level 2 Register

I/O Address:	PMBASE + 14h (ACPI P_BLK+4)	Attribute:	RO
Default Value:	00h	Size:	8 bit
Lockable:	No	Usage:	ACPI or Legacy
Power Well:	Core		

Bit	Description
7:0	Reads to this register return all zeros, writes to this register have no effect. Reads to this register generate a “enter a level 2 power state” (C2) to the clock control logic. This will cause the STPCLK# signal to go active, and stay active until a break event occurs. Throttling (due either to THTL_EN or THRM# override) will be ignored.

9.8.3.7 GPE0_STS—General Purpose Event 0 Status Register

I/O Address:	PMBASE + 28h (ACPI GPE0_BLK)	Attribute:	R/WC, R/W
Default Value:	00000000h	Size:	32 bit
Lockable:	No	Usage:	ACPI
Power Well:	Resume		

Note: This register is symmetrical to the General Purpose Event 0 Enable Register. If the corresponding _EN bit is set, then when the _STS bit gets set, the ICH4 generates a Wake Event. Once back in an S0 state (or if already in an S0 state when the event occurs), the ICH4 also generates an SCI if the SCI_EN bit is set, or an SMI# if the SCI_EN bit is not set. There is no SCI/SMI# or wake event on THRMOR_STS since there is no corresponding _EN bit. None of these bits are reset by CF9h write. All are reset by RSMRST#.

Bit	Description
31:16	<p>GPI[n]_STS — R/WC. These bits are set any time the corresponding GPIO is set up as an input and the corresponding GPIO signal is high (or low if the corresponding GP_INV bit is set). If the corresponding enable bit is set in the GPE0_EN register, then when the GPI[n]_STS bit is set:</p> <ul style="list-style-type: none"> • If the system is in an S1–S5 state, the event will also wake the system. • If the system is in an S0 state (or upon waking back to an S0 state), a SCI will be caused depending on the GPI_ROUT bits for the corresponding GPI.
15:14	Reserved
13	<p>PME_B0_STS — R/WC.</p> <p>0 = Software clears this bit by writing a 1 to the bit position. (default)</p> <p>1 = This bit will be set to 1 by the Intel® ICH4 when any internal device on bus 0 asserts the equivalent of the PME# signal. Additionally, if the PME_B0_EN bit is set, and the system is in an S0 state, then the setting of the PME_B0_STS bit will generate an SCI (or SMI# if SCI_EN is not set). If the PME_B0_STS bit is set, and the system is in an S1–S4 state (or S5 state due to SLP_TYP and SLP_EN), then the setting of the PME_B0_STS bit will generate a wake event, and an SCI (or SMI# if SCI_EN is not set) will be generated. If the system is in an S5 state due to power button override, then the PME_B0_STS bit will not cause a wake event or SCI.</p>
12	<p>USB3_STS — R/W</p> <p>0 = Disable.</p> <p>1 = Set by hardware and can be reset by writing a one to this bit position or a resume-well reset. This bit is set when USB UHCI controller #3 needs to cause a wake. Additionally if the USB3_EN bit is set, the setting of the USB3_STS bit will generate a wake event.</p>
11	<p>PME_STS — R/WC.</p> <p>0 = Software clears this bit by writing a 1 to the bit position.</p> <p>1 = Set by hardware when the PME# signal goes active. Additionally, if the PME_EN bit is set, and the system is in an S0 state, then the setting of the PME_STS bit will generate an SCI or SMI# (if SCI_EN is not set). If the PME_EN bit is set, and the system is in an S1–S4 state (or S5 state due to setting SLP_TYP and SLP_EN), then the setting of the PME_STS bit will generate a wake event, and an SCI will be generated. If the system is in an S5 state due to power button override or a power failure, then PME_STS will not cause a wake event or SCI.</p>
10:9	Reserved
8	<p>RI_STS — R/WC.</p> <p>0 = Software clears this bit by writing a 1 to the bit position.</p> <p>1 = Set by hardware when the RI# input signal goes active.</p>

Bit	Description
7	<p>SMBus Wake Status (SMB_WAK_STS) — R/WC. The SMBus controller can independently cause an SMI# or SCI, so this bit does not need to do so (unlike the other bits in this register).</p> <p>0 = Software clears this bit by writing a 1 to the bit position.</p> <p>1 = Set by hardware to indicate that the wake event was caused by the ICH4's SMBus logic. This bit will be set by the WAKE/SMI# command type, even if the system is already awake. The SMI handler should then clear this bit.</p> <p>NOTES:</p> <ol style="list-style-type: none"> This bit is set by the SMBus slave command 01h (Wake/SMI#) even when the system is in the S0 state. Therefore, to avoid an instant wake on subsequent transitions to sleep states, software must clear this bit after each reception of the Wake/SMI# command or just prior to entering the sleep state. If SMB_WAK_STS is set due to SMBus slave receiving a message, it will be cleared by internal logic when a THRMTRIP# event happens or a Power Button Override event. However, THRMTRIP# or Power Button Override event will not clear SMB_WAK_STS if it is set due to SMBALERT# signal going active. The SMBALERT_STS bit (D31:F3:I/O Offset 00h:Bit 5) should be cleared by software before this bit is cleared.
6	<p>TCOSCI_STS — R/WC.</p> <p>0 = Software clears this bit by writing a 1 to the bit position.</p> <p>1 = Set by hardware when the TCO logic causes an SCI.</p>
5	<p>AC97_STS — R/WC. This bit will be set to 1 by when the codecs are attempting to wake the system and the PME events for the codecs are armed for wakeup. A PME is armed by programming the appropriate PMEE bit in the Power Management Control and Status register at bit 8 of offset 54h in each AC '97 function.</p> <p>0 = Software clears this bit by writing a 1 to the bit position.</p> <p>1 = Set by hardware when the codecs are attempting to wake the system. The AC97_STS bit gets set only from the following two cases:</p> <ul style="list-style-type: none"> The PMEE bit for the function is set, and o The AC-link bit clock has been shut and the routed AC_SDIN line is high (for audio, if routing is disabled, no wake events are allowed. For modem, if audio routing is disabled, then the wake event is an OR of all AC_SDIN lines. If routing is enabled, then the wake event for modem is the remaining non-routed AC_SDIN line), or o GPI Status Change Interrupt bit (NABMBAR + 30h, bit 0) is 1. <p>This bit is not affected by a hard reset caused by a CF9h write.</p>
4	<p>USB2_STS — R/WC.</p> <p>0 = Software clears this bit by writing a 1 to the bit position.</p> <p>1 = Set by hardware when USB UHCI controller 2 needs to cause a wake. Wake event will be generated if the corresponding USB2_EN bit is set.</p>
3	<p>USB1_STS — R/WC.</p> <p>0 = Software clears this bit by writing a 1 to the bit position.</p> <p>1 = Set by hardware when USB UHCI controller 1 needs to cause a wake. Wake event will be generated if the corresponding USB1_EN bit is set.</p>
2	Reserved
1	<p>Thermal Interrupt Override Status (THRMOR_STS) — R/WC.</p> <p>0 = Software clears this bit by writing a 1 to the bit position.</p> <p>1 = This bit is set by hardware anytime a thermal over-ride condition occurs and starts throttling the processor's clock at the THRM_DTY ratio. This will not cause an SMI#, SCI, or wake event.</p>
0	<p>Thermal Interrupt Status (THRM_STS) — R/WC.</p> <p>0 = Software clears this bit by writing a 1 to the bit position.</p> <p>1 = Set by hardware anytime the THRM# signal is driven active as defined by the THRM_POL bit. Additionally, if the THRM_EN bit is set, then the setting of the THRM_STS bit will also generate a power management event (SCI or SMI#).</p>

9.8.3.8 GPE0_EN—General Purpose Event 0 Enables Register

I/O Address:	PMBASE + 2Ch (ACPI GPE0_BLK + 2)	Attribute:	R/W
Default Value:	00000000h	Size:	32-bit
Lockable:	No	Usage:	ACPI
Power Well:	Bits 0–7, 12, 16–31 Resume, Bits 8–11, 13–15 RTC		

Note: This register is symmetrical to the General Purpose Event 0 Status Register. All the bits in this register should be cleared to 0 based on a Power Button Override. The resume well bits are all cleared by RSMRST#. The RTC sell bits are cleared by RTCRST#.

Bit	Description
31:16	GPI_n_EN — R/W. These bits enable the corresponding GPI[n]_STS bits being set to cause a SCI, and/or wake event. These bits are cleared by RSMRST#.
15:14	Reserved
13	PME_B0_EN — R/W. Enables the setting of the PME_B0_STS bit to generate a wake event and/or an SCI or SMI#. PME_B0_STS can be a wake event from the S1–S4 states, or from S5 (if entered via SLP_TYP and SLP_EN) or power failure, but not Power Button Override. This bit defaults to 0. It is only cleared by Software or RTCRST#. It is not cleared by CF9h writes.
12	USB3_EN — R/W. 0 = Disable. 1 = Enable the setting of the USB3_STS bit to generate a wake event. The USB3_STS bit is set anytime USB UHCI controller #3 signals a wake event. Break events are handled via the USB interrupt.
11	PME_EN — R/W. 0 = Disable. 1 = Enables the setting of the PME_STS to generate a wake event and/or an SCI. PME# can be a wake event from the S1–S4 state or from S5 (if entered via SLP_EN, but not power button override).
10	Reserved
9	Reserved
8	RI_EN — R/W. The value of this bit will be maintained through a G3 state and is not affected by a hard reset caused by a CF9h write. 0 = Disable. 1 = Enables the setting of the RI_STS to generate a wake event.
7	Reserved
6	TCOSCI_EN — R/W. 0 = Disable. 1 = Enables the setting of the TCOSCI_STS to generate an SCI.
5	AC97_EN — R/W. 0 = Disable. 1 = Enables the setting of the AC97_STS to generate a wake event.
4	USB2_EN — R/W. 0 = Disable. 1 = Enable the setting of the USB2_STS bit to generate a wake event. The USB2_STS bit is set anytime USB UHCI controller #2 signals a wake event. Break events are handled via the USB interrupt.

Bit	Description
3	USB1_EN — R/W. 0 = Disable. 1 = Enable the setting of the USB1_STS bit to generate a wake event. The USB1_STS bit is set anytime USB UHCI controller #1 signals a wake event. Break events are handled via the USB interrupt.
2	THRM#_POL — R/W. This bit controls the polarity of the THRM# pin needed to set the THRM_STS bit. 0 = Low value on the THRM# signal will set the THRM_STS bit. 1 = HIGH value on the THRM# signal will set the THRM_STS bit.
1	Reserved
0	THRM_EN — R/W. 0 = Disable. 1 = Active assertion of the THRM# signal (as defined by the THRM_POL bit) will set the THRM_STS bit and generate a power management event (SCI or SMI).

9.8.3.9 SMI_EN—SMI Control and Enable Register

I/O Address:	PMBASE + 30h	Attribute:	R/W, WO, R/W-Special
Default Value:	0000h	Size:	32 bit
Lockable:	No	Usage:	ACPI or Legacy
Power Well:	Core		

Bit	Description
31:19	Reserved
18	INTEL_USB2_EN — R/W. 0 = Disable. 1 = Enables Intel-Specific USB EHCI SMI logic to cause SMI#.
17	LEGACY_USB2_EN — R/W. 0 = Disable. 1 = Enables legacy USB EHCI logic to cause SMI#.
16:15	Reserved
14	PERIODIC_EN — R/W. 0 = Disable. 1 = Enables the Intel® ICH4 to generate an SMI# when the PERIODIC_STS bit is set in the SMI_STS register.
13	TCO_EN — R/W. 0 = Disables TCO logic generating an SMI#. Note that if the NMI2SMI_EN bit is set, SMIs that are caused by re-routed NMIs will not be gated by the TCO_EN bit. Even if the TCO_EN bit is 0, NMIs will still be routed to cause SMIs. 1 = Enables the TCO logic to generate SMI#.
12	Reserved
11	Microcontroller SMI Enable (MCSMI_EN) — R/W. 0 = Disable. 1 = Enables ICH4 to trap accesses to the microcontroller range (62h or 66h) and generate an SMI#. Note that “trapped” cycles will be claimed by the ICH4 on PCI, but not forwarded to LPC.
10:8	Reserved

Bit	Description
7	<p>BIOS Release (BIOS_RLS) — WO.</p> <p>0 = This bit will always return 0 on reads. Writes of 0 to this bit have no effect.</p> <p>1 = Enables the generation of an SCI interrupt for ACPI software when a one is written to this bit position by BIOS software.</p>
6	<p>Software SMI# Timer Enable (SWSMI_TMR_EN) — R/W.</p> <p>0 = Disable. Clearing the SWSMI_TMR_EN bit before the timer expires will reset the timer and the SMI# will not be generated.</p> <p>1 = Starts Software SMI# Timer. When the SWSMI timer expires (the timeout period depends upon the SWSMI_RATE_SEL bit setting), SWSMI_TMR_STS is set and an SMI# is generated. SWSMI_TMR_EN stays set until cleared by software.</p>
5	<p>APMC_EN — R/W.</p> <p>0 = Disable. Writes to the APM_CNT register will not cause an SMI#.</p> <p>1 = Enables writes to the APM_CNT register to cause an SMI#.</p>
4	<p>SLP_SMI_EN — R/W.</p> <p>0 = Disables the generation of SMI# on SLP_EN. Note that this bit must be 0 before the software attempts to transition the system into a sleep state by writing a 1 to the SLP_EN bit.</p> <p>1 = A write of 1 to the SLP_EN bit (bit 13 in PM1_CNT register) will generate an SMI#, and the system will not transition to the sleep state based on that write to the SLP_EN bit.</p>
3	<p>LEGACY_USB_EN — R/W.</p> <p>0 = Disable.</p> <p>1 = Enables legacy USB circuit to cause SMI#.</p>
2	<p>BIOS_EN — R/W.</p> <p>0 = Disable.</p> <p>1 = Enables the generation of SMI# when ACPI software writes a 1 to the GBL_RLS bit.</p>
1	<p>End of SMI (EOS) — R/W-Special. This bit controls the arbitration of the SMI signal to the processor. This bit must be set for the ICH4 to assert SMI# low to the processor.</p> <p>0 = Once the ICH4 asserts SMI# low, the EOS bit is automatically cleared.</p> <p>1 = When this bit is set, SMI# signal will be deasserted for 4 PCI clocks before its assertion. In the SMI handler, the CPU should clear all pending SMIs (by servicing them and then clearing their respective status bits), set the EOS bit, and exit SMM. This will allow the SMI arbiter to re-assert SMI upon detection of an SMI event and the setting of a SMI status bit.</p> <p>NOTE: ICH4 is able to generate 1st SMI after reset even though EOS bit is not set. Subsequent SMI require EOS bit is set.</p>
0	<p>GBL_SMI_EN — R/W.</p> <p>0 = No SMI# will be generated by ICH4. This bit is reset by a PCI reset event.</p> <p>1 = Enables the generation of SMI# in the system upon any enabled SMI event.</p>

9.8.3.10 SMI_STS—SMI Status Register

I/O Address:	PMBASE + 34h	Attribute:	R/WC, RO
Default Value:	0000h	Size:	32-bit
Lockable:	No	Usage:	ACPI or Legacy
Power Well:	Core		

Note: If the corresponding _EN bit is set when the _STS bit is set, the ICH4 will cause an SMI# (except bits 8:10 and 12, which don't need enable bits since they are logic ORs of other registers that have enable bits). The ICH4 uses the same GPE0_EN register (I/O address: PMBase+2Ch) to enable/disable both SMI and ACPI SCI general purpose input events. ACPI OS assumes that it owns the entire GPE0_EN register per ACPI spec. Problems arise when some of the general-purpose inputs are enabled as SMI by BIOS, and some of the general purpose inputs are enabled for SCI. In this case ACPI OS turns off the enabled bit for any GPIx input signals that are not indicated as SCI general-purpose events at boot, and exit from sleeping states. BIOS should define a dummy control method which prevents the ACPI OS from clearing the SMI GPE0_EN bits.

Bit	Description
31:19	Reserved
18	INTEL_USB2_STS — RO. This non-sticky read-only bit is a logical OR of each of the SMI status bits in the Intel-Specific USB EHCI SMI Status Register ANDed with the corresponding enable bits. This bit will not be active if the enable bits are not set. Writes to this bit have no effect.
17	LEGACY_USB2_STS — RO. This non-sticky read-only bit is a logical OR of each of the SMI status bits in the USB EHCI Legacy Support Register ANDed with the corresponding enable bits. This bit will not be active if the enable bits are not set. Writes to this bit will have no effect.
16	SMBus SMI Status (SMBUS_SMI_STS) — R/WC. 0 = This bit is cleared by writing a 1 to its bit position. This bit is set from the 64 KHz clock domain used by the SMBus. Software must wait at least 15.63 us after the initial assertion of this bit before clearing it. 1 = Indicates that the SMI# was caused by: <ul style="list-style-type: none"> • The SMBus Slave receiving a message, or • The SMBALERT# signal goes active and the SMB_SMI_EN bit is set and the SMBALERT_DIS bit is cleared, or • The SMBus Slave receiving a Host Notify message and the HOST_NOTIFY_INTREN and the SMB_SMI_EN bits are set, or • The Intel® ICH4 detecting the SMLINK_SLAVE_SMI command while in the S0 state.
15	SERIRQ_SMI_STS — RO. 0 = SMI# was not caused by SERIRQ decoder. This is not a sticky bit. 1 = SMI# was caused by the SERIRQ decoder.
14	PERIODIC_STS — R/WC. • This bit is cleared by writing a 1 to its bit position. 1 = This bit will be set at the rate determined by the PER_SMI_SEL bits. If the PERIODIC_EN bit is also set, the ICH4 will generate an SMI#.
13	TCO_STS — RO. 0 = SMI# not caused by TCO logic. 1 = SMI# was caused by the TCO logic. Note that this is not a wake event.

Bit	Description
12	<p>Device Monitor Status (DEVMON_STS) — RO.</p> <p>0 = SMI# not caused by Device Monitor.</p> <p>1 = Set under any of the following conditions:</p> <ul style="list-style-type: none"> Any of the DEV[7:4]_TRAP_STS bits are set and the corresponding DEV[7:4]_TRAP_EN bits are also set. Any of the DEVTRAP_STS bits are set and the corresponding DEVTRAP_EN bits are also set.
11	<p>Microcontroller SMI# Status (MCSMI_STS) — R/WC.</p> <p>0 = Indicates that there has been no access to the power management microcontroller range (62h or 66h). This bit is cleared by software writing a 1 to the bit position.</p> <p>1 = Set if there has been an access to the power management microcontroller range (62h or 66h). If this bit is set and the MCSMI_EN bit is also set, the ICH4 will generate an SMI#.</p>
10	<p>GPE0_STS — RO. This bit is a logical OR of the bits in the ALT_GP_SMI_STS register that are also set up to cause an SMI# (as indicated by the GPI_ROUT registers) and have the corresponding bit set in the ALT_GP_SMI_EN register. Bits that are not routed to cause an SMI# will have no effect on this bit.</p> <p>0 = SMI# was not generated by a GPI assertion.</p> <p>1 = SMI# was generated by a GPI assertion.</p>
9	<p>GPE0_STS — RO. This bit is a logical OR of the bits in the GPE0_STS register that also have the corresponding bit set in the GPE0_EN register.</p> <p>0 = SMI# was not generated by a GPE0 event.</p> <p>1 = SMI# was generated by a GPE0 event.</p>
8	<p>PM1_STS_REG — RO. This is an ORs of the bits in the ACPI PM1 Status Register (offset PMBASE+00h) that can cause an SMI#.</p> <p>0 = SMI# was not generated by a PM1_STS event.</p> <p>1 = SMI# was generated by a PM1_STS event.</p>
7	Reserved
6	<p>SWSMI_TMR_STS — R/WC.</p> <p>0 = Software clears this bit by writing a 1 to the bit location.</p> <p>1 = Set by the hardware when the Software SMI# Timer expires.</p>
5	<p>APM_STS — R/WC.</p> <p>0 = Software clears this bit by writing a 1 to the bit location.</p> <p>1 = SMI# was generated by a write access to the APM control register with the APMC_EN bit set.</p>
4	<p>SLP_SMI_STS — R/WC.</p> <p>0 = Software clears this bit by writing a 1 to the bit location.</p> <p>1 = Indicates an SMI# was caused by a write of 1 to SLP_EN bit when SLP_SMI_EN bit is also set.</p>
3	<p>LEGACY_USB_STS — RO. This bit is a logical OR of each of the SMI status bits in the USB Legacy Keyboard/Mouse Control Registers ANDed with the corresponding enable bits. This bit will not be active if the enable bits are not set.</p> <p>0 = SMI# was not generated by USB Legacy event.</p> <p>1 = SMI# was generated by USB Legacy event.</p>
2	<p>BIOS_STS — R/WC.</p> <p>0 = Software clears this bit by writing a 1 to the bit location.</p> <p>1 = SMI# was generated due to ACPI software requesting attention (writing a 1 to the GBL_RLS bit with the BIOS_EN bit set).</p>
1:0	Reserved

9.8.3.11 ALT_GP_SMI_EN—Alternate GPI SMI Enable Register

I/O Address:	PMBASE +38h	Attribute:	R/W
Default Value:	0000h	Size:	16 bit
Lockable:	No	Usage:	ACPI or Legacy
Power Well:	Resume		

Bit	Description
15:0	Alternate GPI SMI Enable — R/W. These bits are used to enable the corresponding GPIO to cause an SMI#. For these bits to have any effect, the following must be true. <ul style="list-style-type: none"> The corresponding bit in the ALT_GP_SMI_EN register is set. The corresponding GPI must be routed in the GPI_ROUT register to cause an SMI. The corresponding GPIO must be implemented.

9.8.3.12 ALT_GP_SMI_STS—Alternate GPI SMI Status Register

I/O Address:	PMBASE +3Ah	Attribute:	R/WC
Default Value:	0000h	Size:	16 bit
Lockable:	No	Usage:	ACPI or Legacy
Power Well:	Resume		

Bit	Description
15:0	Alternate GPI SMI Status — R/WC. These bits report the status of the corresponding GPIs. 1 = active, 0 = inactive. These bits are sticky. If the following conditions are true, an SMI# will be generated and the GPE0_STS bit set: <ul style="list-style-type: none"> The corresponding bit in the ALT_GPI_SMI_EN register is set The corresponding GPI must be routed in the GPI_ROUT register to cause an SMI. The corresponding GPIO must be implemented. All bits are in the resume well. Default for these bits is dependent on the state of the GPI pins.

9.8.3.13 MON_SMI—Device Monitor SMI Status and Enable Register

I/O Address:	PMBASE +40h	Attribute:	R/W, R/WC
Default Value:	0000h	Size:	16 bit
Lockable:	No	Usage:	Legacy Only
Power Well:	Core		

Bit	Description
15:12	DEV[7:4]_TRAP_STS — R/WC. Bit 12 corresponds to Monitor 4, bit 13 corresponds to Monitor 5 etc. 0 = SMI# was not caused by the associated device monitor. 1 = SMI# was caused by an access to the corresponding device monitor's I/O range.
11:8	DEV[7:4]_TRAP_EN — R/W. Bit 8 corresponds to Monitor 4, bit 9 corresponds to Monitor 5 etc. 0 = Disable. 1 = Enables SMI# due to an access to the corresponding device monitor's I/O range.
7:0	Reserved

9.8.3.14 DEVACT_STS — Device Activity Status Register

I/O Address:	PMBASE +44h	Attribute:	R/WC
Default Value:	0000h	Size:	16 bit
Lockable:	No	Usage:	Legacy Only
Power Well:	Core		

This register is used in conjunction with the Periodic SMI# timer to detect any system activity for legacy power management.

Bit	Description
15:14	Reserved
13	ADLIB_ACT_STS — R/WC. Ad-Lib. 0 = Indicates that there has been no access to this device's I/O range. 1 = This device's I/O range has been accessed. Clear this bit by writing a 1 to the bit location.
12	KBC_ACT_STS — R/WC. KBC (60/64h). 0 = Indicates that there has been no access to this device's I/O range. 1 = This device's I/O range has been accessed. Clear this bit by writing a 1 to the bit location.
11	MIDI_ACT_STS — R/WC. MIDI. 0 = Indicates that there has been no access to this device's I/O range. 1 = This device's I/O range has been accessed. Clear this bit by writing a 1 to the bit location.
10	AUDIO_ACT_STS — R/WC. Audio (Sound Blaster "OR'd" with MSS). 0 = Indicates that there has been no access to this device's I/O range. 1 = This device's I/O range has been accessed. Clear this bit by writing a 1 to the bit location.
9	PIRQDH_ACT_STS — R/WC. PIRQ[D or H]. 0 = The corresponding PCI interrupts have not been active. 1 = At least one of the corresponding PCI interrupts has been active. Clear this bit by writing a 1 to the bit location.
8	PIRQCG_ACT_STS — R/WC. PIRQ[C or G]. 0 = The corresponding PCI interrupts have not been active. 1 = At least one of the corresponding PCI interrupts has been active. Clear this bit by writing a 1 to the bit location.
7	PIRQBF_ACT_STS — R/WC. PIRQ[B or F]. 0 = The corresponding PCI interrupts have not been active. 1 = At least one of the corresponding PCI interrupts has been active. Clear this bit by writing a 1 to the bit location.
6	PIRQAE_ACT_STS — R/WC. PIRQ[A or E]. 0 = The corresponding PCI interrupts have not been active. 1 = At least one of the corresponding PCI interrupts has been active. Clear this bit by writing a 1 to the bit location.
5	LEG_ACT_STS — R/WC. Parallel Port, Serial Port 1, Serial Port 2, Floppy Disk controller. 0 = Indicates that there has been no access to this device's I/O range. 1 = This device's I/O range has been accessed. Clear this bit by writing a 1 to the bit location.
4	Reserved
3	IDES1_ACT_STS — R/WC. IDE Secondary Drive 1. 0 = Indicates that there has been no access to this device's I/O range. 1 = This device's I/O range has been accessed. Clear this bit by writing a 1 to the bit location.

Bit	Description
2	IDES0_ACT_STS — R/WC. IDE Secondary Drive 0. 0 = Indicates that there has been no access to this device's I/O range. 1 = This device's I/O range has been accessed. Clear this bit by writing a 1 to the bit location.
1	IDEP1_ACT_STS — R/WC. IDE Primary Drive 1. 0 = Indicates that there has been no access to this device's I/O range. 1 = This device's I/O range has been accessed. Clear this bit by writing a 1 to the bit location.
0	IDEP0_ACT_STS — R/WC. IDE Primary Drive 0. 0 = Indicates that there has been no access to this device's I/O range. 1 = This device's I/O range has been accessed. Clear this bit by writing a 1 to the bit location.

9.8.3.15 **DEVTRAP_EN**— Device Trap Enable Register

I/O Address:	PMBASE +48h	Attribute:	R/W
Default Value:	0000h	Size:	16 bit
Lockable:	No	Usage:	Legacy Only
Power Well:	Core		

This register enables the individual trap ranges to generate an SMI# when the corresponding status bit in the DEVACT_STS register is set. When a range is enabled, I/O cycles associated with that range will not be forwarded to LPC or IDE.

Bit	Description
15:14	Reserved
13	ADLIB_TRP_EN — R/W. Ad-Lib. 0 = Disable. 1 = Enable.
12	KBC_TRP_EN — R/W. KBC (60/64h). 0 = Disable. 1 = Enable.
11	MIDI_TRP_EN — R/W. MIDI. 0 = Disable. 1 = Enable.
10	AUDIO_TRP_EN — R/W. Audio (Sound Blaster "OR'd" with MSS). 0 = Disable. 1 = Enable.
9:6	Reserved
5	LEG_IO_TRP_EN — R/W. Parallel Port, Serial Port 1, Serial Port 2, Floppy Disk controller. 0 = Disable. 1 = Enable.
4	Reserved
3	IDES1_TRP_EN — R/W. IDE Secondary Drive 1. 0 = Disable. 1 = Enable.

Bit	Description
2	IDES0_TRP_EN — R/W. IDE Secondary Drive 0. 0 = Disable. 1 = Enable.
1	IDEP1_TRP_EN — R/W. IDE Primary Drive 1. 0 = Disable. 1 = Enable.
0	IDEP0_TRP_EN — R/W. IDE Primary Drive 0. 0 = Disable. 1 = Enable.

9.8.3.16 **BUS_ADDR_TRACK**— Bus Address Tracker

I/O Address:	PMBASE +4Ch	Attribute:	RO
Lockable:	No	Size:	16 bit
Power Well:	Core	Usage:	Legacy Only

This register could be used by the SMI# handler to assist in determining what was the last cycle from the processor. **BUS_ADDR_TRACK** may not contain “expected” last I/O cycle data if Asynchronous SMIs and Synchronous SMIs are occurring simultaneously. This register only reports “expected” last I/O cycle data if Asynchronous SMIs are disabled.

Bit	Description
15:0	Corresponds to the low 16 bits of the last I/O cycle, as would be defined by the PCI AD[15:0] signals on the PCI bus (even though it may not be a real PCI cycle). The value is latched based on SMI# active. This functionality is useful for figuring out which I/O was last being accessed.

9.8.3.17 **BUS_CYC_TRACK**— Bus Cycle Tracker

I/O Address:	PMBASE +4Eh	Attribute:	RO
Lockable:	No	Size:	8 bit
Power Well:	Core	Usage:	Legacy Only

This register could be used by the SMM handler to assist in determining what was the last cycle from the CPU. **BUS_CYC_TRACK** may not contain “expected” last I/O cycle data if Asynchronous SMIs and Synchronous SMIs are occurring simultaneously. This register only reports “expected” last I/O cycle data if Asynchronous SMIs are disabled.

Bit	Description
7:4	Corresponds to the byte enables, as would be defined by the PCI C/BE# signals on the PCI bus (even though it may not be a real PCI cycle). The value is latched based on SMI# going active.
3:0	Corresponds to the cycle type, as would be defined by the PCI C/BE# signals on the PCI bus (even though it may not be a real PCI cycle). The value is latched based on SMI# going active.

9.9 System Management TCO Registers (D31:F0)

The TCO logic is accessed via registers mapped to the PCI configuration space (Device 31:Function 0) and the system I/O space. For TCO PCI Configuration registers, see LPC Device 31:Function 0 PCI Configuration registers.

The TCO I/O registers reside in a 32-byte range pointed to by a TCOBASE value, which is, ACPIBASE + 60h in the PCI configuration space. [Table 9-11](#) shows the mapping of the registers within that 32-byte range. Each register is described in the following sections.

Table 9-11. TCO I/O Register Map

Offset	Mnemonic	Register Name	Type
00h	TCO_RLD	TCO Timer Reload and Current Value	R/W
01h	TCO_TMR	TCO Timer Initial Value	R/W
02h	TCO_DAT_IN	TCO Data In	R/W
03h	TCO_DAT_OUT	TCO Data Out	R/W
04h–05h	TCO1_STS	TCO Status	R/W, RO
06h–07h	TCO2_STS	TCO Status	R/W
08h–09h	TCO1_CNT	TCO Control	R/W, R/WC, R/W-Special
0Ah–0Bh	TCO2_CNT	TCO Control	R/W
0Ch–0Dh	TCO_MESSAGE1 TCO_MESSAGE2	Used by BIOS to indicate POST/Boot progress	R/W
0Eh	TCO_WDSTATUS	Watchdog Status Register	R/W
0Fh	—	Reserved	RO
10h	SW_IRQ_GEN	Software IRQ Generation Register	R/W
11h–1Fh	—	Reserved	RO

9.9.1 TCO1_RLD—TCO Timer Reload and Current Value Register

I/O Address:	TCOBASE +00h	Attribute:	R/W
Default Value:	0000h	Size:	8 bit
Lockable:	No	Power Well:	Core

Bit	Description
7:0	Reading this register will return the current count of the TCO timer. Writing any value to this register will reload the timer to prevent the timeout. Bits 7:6 will always be 0.

9.9.2 TCO1_TMR—TCO Timer Initial Value Register

I/O Address: TCOBASE +01h Attribute: R/W
 Default Value: 0004h Size: 8 bit
 Lockable: No Power Well: Core

Bit	Description
7:6	Reserved
5:0	Value that is loaded into the timer each time the TCO_RLD register is written. Values of 0h–3h will be ignored and should not be attempted. The timer is clocked at approximately 0.6 seconds, and this allows timeouts ranging from 2.4 seconds to 38 seconds.

9.9.3 TCO1_DAT_IN—TCO Data In Register

I/O Address: TCOBASE +02h Attribute: R/W
 Default Value: 0000h Size: 8 bit
 Lockable: No Power Well: Core

Bit	Description
7:0	Data Register for passing commands from the OS to the SMI handler. Writes to this register will cause an SMI and set the OS_TCO_SMI bit in the TCO_STS register.

9.9.4 TCO1_DAT_OUT—TCO Data Out Register

I/O Address: TCOBASE +03h Attribute: R/W
 Default Value: 0000h Size: 8 bit
 Lockable: No Power Well: Core

Bit	Description
7:0	Data Register for passing commands from the SMI handler to the OS. Writes to this register will set the TCO_INT_STS bit in the TCO_STS register. It will also cause an interrupt, as selected by the TCO_INT_SEL bits.

9.9.5 TCO1_STS—TCO1 Status Register

I/O Address:	TCOBASE +04h	Attribute:	R/WC, RO
Default Value:	0000h	Size:	16 bit
Lockable:	No	Power Well:	Core (Except bit 7, in RTC)

Bit	Description
15:13	Reserved
12	<p>HUBSERR_STS — R/WC.</p> <p>0 = Software clears this bit by writing a 1 to the bit position.</p> <p>1 = Intel® ICH4 received an SERR# message via the hub interface. The software must read the memory controller hub (or its equivalent) to determine the reason for the SERR#.</p> <p>NOTE: If this bit is set AND the SERR_EN bit in CMD register (D30:F0, Offset 04h, bit 8) is also set, the ICH4 will set the SSE bit in SECSTS register (D30:F0, offset 1Eh, bit 14) AND will also generate a NMI (or SMI# if NMI routed to SMI#).</p>
11	<p>HUBNMI_STS — R/WC.</p> <p>0 = Software clears this bit by writing a 1 to the bit position.</p> <p>1 = ICH4 received an NMI message via the hub interface. The software must read the memory controller hub (or its equivalent) to determine the reason for the NMI.</p>
10	<p>HUBSMI_STS — R/WC.</p> <p>0 = Software clears this bit by writing a 1 to the bit position.</p> <p>1 = ICH4 received an SMI message via the hub interface. The software must read the memory controller hub (or its equivalent) to determine the reason for the SMI#.</p>
9	<p>HUBSCI_STS — R/WC.</p> <p>0 = Software clears this bit by writing a 1 to the bit position.</p> <p>1 = ICH4 received an SCI message via the hub interface. The software must read the memory controller hub (or its equivalent) to determine the reason for the SCI.</p>
8	<p>BIOSWR_STS — R/WC.</p> <p>0 = Software clears this bit by writing a 1 to the bit position.</p> <p>1 = ICH4 sets this bit and generates an SMI# to indicate an illegal attempt to write to the BIOS. This occurs when either:</p> <ul style="list-style-type: none"> The BIOSWP bit is changed from 0 to 1 and the BLD bit is also set, or Any write is attempted to the BIOS and the BIOSWP bit is also set. <p>NOTE: On write cycles attempted to the 4-MB lower alias to the BIOS space, the BIOSWR_STS will not be set.</p>
7	<p>NEWCENTURY_STS — R/WC. This bit is in the RTC well.</p> <p>0 = Cleared by writing a 1 to the bit position or by RTCRST# going active.</p> <p>1 = This bit is set when the Year byte (RTC I/O space, index offset 09h) rolls over from 99 to 00. Setting this bit will cause an SMI# (but not a wake event).</p> <p>Note that the NEWCENTURY_STS bit is not valid when the RTC battery is first installed (or when RTC power has not been maintained). Software can determine if RTC power has not been maintained by checking the RTC_PWR_STS bit, or by other means (e.g., a checksum on RTC RAM). If RTC power is determined to have not been maintained, BIOS should set the time to a legal value and then clear the NEWCENTURY_STS bit.</p> <p>The NEWCENTURY_STS bit may take up to 3 RTC clocks for the bit to be cleared after a 1 is written to the bit to clear it. After writing a 1 to this bit, software should not exit the SMI handler until verifying that the bit has actually been cleared. This will ensure that the SMI is not re-entered.</p>
6:4	Reserved

Bit	Description
3	TIMEOUT — R/WC. 0 = Software clears this bit by writing a 1 to the bit position. 1 = Set by ICH4 to indicate that the SMI was caused by the TCO timer reaching 0.
2	TCO_INT_STS — R/WC. 0 = Software clears this bit by writing a 1 to the bit position. 1 = SMI handler caused the interrupt by writing to the TCO_DAT_OUT register.
1	SW_TCO_SMI — R/WC. 0 = Software clears this bit by writing a 1 to the bit position. 1 = Software caused an SMI# by writing to the TCO_DAT_IN register.
0	NMI2SMI_STS — RO. 0 = Cleared by clearing the associated NMI status bit. 1 = Set by the ICH4 when an SMI# occurs because an event occurred that would otherwise have caused an NMI (because NMI2SMI_EN is set).

9.9.6 TCO2_STS—TCO2 Status Register

I/O Address:	TCOBASE +06h	Attribute:	R/WC
Default Value:	0000h	Size:	16 bit
Lockable:	No	Power Well:	Resume (Except Bit 0, in RTC)

Bit	Description
15:5	Reserved
4	SMLink Slave SMI Status (SMLINK_SLV_SMI_STS) — R/WC. This allow the software to go directly into pre-determined sleep state. This avoids race conditions. 0 = The bit is reset by RSMRST#, but not due to the PCI Reset associated with exit from S3–S5 states. Software clears the bit by writing a 1 to this bit position. 1 = Intel® ICH4 sets this bit to 1 when it receives the SMI message on the SMLink's Slave Interface.
3	Reserved
2	BOOT_STS — R/WC. 0 = Cleared by ICH4 based on RSMRST# or by software writing a 1 to this bit. Note that software should first clear the SECOND_TO_STS bit before writing a 1 to clear the BOOT_STS bit. 1 = Set to 1 when the SECOND_TO_STS bit goes from 0 to 1 and the processor has not fetched the first instruction. If rebooting due to a second TCO timer timeout, and if the BOOT_STS bit is set, the ICH4 will reboot using the 'safe' multiplier (1111). This allows the system to recover from a CPU frequency multiplier that is too high, and allows the BIOS to check the BOOT_STS bit at boot. If the bit is set and the frequency multiplier is 1111, then the BIOS knows that the processor has been programmed to an illegal multiplier.
1	SECOND_TO_STS — R/WC. 0 = This bit is cleared by writing a 1 to the bit position or by a RSMRST#. 1 = The ICH4 sets this bit to a 1 to indicate that the TCO timer timed out a second time (probably due to system lock). If this bit is set and the NO_REBOOT configuration bit is 0, then the ICH4 will reboot the system after the second timeout. The reboot is done by asserting PCIRST#. NOTE: BIOS should always clear this bit before executing SMBus reads and writes.
0	Intruder Detect (INTRD_DET) — R/WC. 0 = This bit is only cleared by writing a 1 to the bit position, or by RTCRST# assertion. 1 = Set by ICH4 to indicate that an intrusion was detected. This bit is set even if the system is in G3 state.

9.9.7 TCO1_CNT—TCO1 Control Register

I/O Address:	TCOBASE +08h	Attribute:	R/W, R/WC, R/W-Special
Default Value:	0000h	Size:	16 bit
Lockable:	No	Power Well:	Core

Bit	Description															
15:12	Reserved															
11	<p>TCO Timer Halt (TCO_TMR_HLT) — R/W.</p> <p>0 = The TCO Timer is enabled to count.</p> <p>1 = The TCO Timer will halt. It will not count, and thus cannot reach a value that will cause an SMI# or set the SECOND_TO_STS bit. When set, this bit will prevent rebooting and prevent Alert On LAN event messages from being transmitted on the SMLINK (but not Alert On LAN* heartbeat messages).</p>															
10	<p>SEND_NOW — R/W-Special.</p> <p>0 = The Intel® ICH4 will clear this bit when it has completed sending the message. Software must not set this bit to 1 again until the ICH4 has set it back to 0.</p> <p>1 = Writing a 1 to this bit will cause the ICH to send an Alert On LAN Event message over the SMLINK interface, with the Software Event bit set.</p> <p>NOTE: Setting the SEND_NOW bit causes the ICH4 integrated LAN controller to reset, which can have unpredictable side-effects. Unless software protects against these side effects, software should not attempt to set this bit.</p>															
9	<p>NMI2SMI_EN — R/W.</p> <p>0 = Normal NMI functionality.</p> <p>1 = Forces all NMIs to instead cause SMIs. The functionality of this bit is dependent upon the settings of the NMI_EN bit and the GBL_SMI_EN bit as detailed in the following table:</p> <table border="1"> <thead> <tr> <th>NMI_EN</th> <th>GBL_SMI_EN</th> <th>Description</th> </tr> </thead> <tbody> <tr> <td>0</td> <td>0</td> <td>No SMI# at all because GBL_SMI_EN = 0</td> </tr> <tr> <td>0</td> <td>1</td> <td>SMI# will be caused due to NMI events</td> </tr> <tr> <td>1</td> <td>0</td> <td>No SMI# at all because GBL_SMI_EN = 0</td> </tr> <tr> <td>1</td> <td>1</td> <td>No SMI# due to NMI because NMI_EN = 1</td> </tr> </tbody> </table>	NMI_EN	GBL_SMI_EN	Description	0	0	No SMI# at all because GBL_SMI_EN = 0	0	1	SMI# will be caused due to NMI events	1	0	No SMI# at all because GBL_SMI_EN = 0	1	1	No SMI# due to NMI because NMI_EN = 1
NMI_EN	GBL_SMI_EN	Description														
0	0	No SMI# at all because GBL_SMI_EN = 0														
0	1	SMI# will be caused due to NMI events														
1	0	No SMI# at all because GBL_SMI_EN = 0														
1	1	No SMI# due to NMI because NMI_EN = 1														
8	<p>NMI_NOW — R/WC.</p> <p>0 = This bit is cleared by writing a 1 to the bit position. The NMI handler is expected to clear this bit. Another NMI will not be generated until the bit is cleared.</p> <p>1 = Writing a 1 to this bit causes an NMI. This allows the BIOS or SMI handler to force an entry to the NMI handler.</p>															
7:0	Reserved															

9.9.8 TCO2_CNT—TCO2 Control Register

I/O Address: TCOBASE +0Ah Attribute: R/W
 Default Value: 0008h Size: 16 bit
 Lockable: No Power Well: Resume

Bit	Description
15:4	Reserved
3	GPIO11_ALERT_DISABLE — R/W. At reset (via RSMRST# asserted) this bit is set and GPIO[11] alerts are disabled. 0 = Enable. 1 = Disable GPIO11/SMBALERT# as an alert source for the heartbeats and the SMBus slave.
2:1	INTRD_SEL — R/W. Selects the action to take if the INTRUDER# signal goes active. 00 = No interrupt or SMI# 01 = Interrupt (as selected by TCO_INT_SEL). 10 = SMI 11 = Reserved
0	Reserved

9.9.9 TCO_MESSAGE1 and TCO_MESSAGE2 Registers

I/O Address: TCOBASE +0Ch (Message 1) Attribute: R/W
 TCOBASE +0Dh (Message 2)
 Default Value: 00h Size: 8 bit
 Lockable: No Power Well: Resume

Bit	Description
7:0	TCO_MESSAGE[n] — R/W. The value written into this register will be sent out via the SMLINK interface in the MESSAGE field of the Alert On LAN message. BIOS can write to this register to indicate its boot progress which can be monitored externally.

9.9.10 TCO_WDSTATUS—TCO2 Control Register

Offset Address: TCOBASE + 0Eh Attribute: R/W
 Default Value: 00h Size: 8 bits
 Power Well: Resume

Bit	Description
7:0	Watchdog Status (WDSTATUS) — R/W. The value written to this register will be sent in the Alert On LAN message on the SMLINK interface. It can be used by the BIOS or system management software to indicate more details on the boot progress. This register will be reset to the default of 00h based on RSMRST# (but not PCI reset).

9.9.11 SW_IRQ_GEN—Software IRQ Generation Register

Offset Address: TCOBASE + 10h Attribute: R/W
 Default Value: 11h Size: 8 bits
 Power Well: Core

Bit	Description
7:2	Reserved
1	IRQ12_CAUSE — R/W. The state of this bit is logically ANDed with the IRQ12 signal as received by the Intel® ICH4's SERIRQ logic. This bit must be a 1 (default) if the ICH4 is expected to receive IRQ12 assertions from a SERIRQ device.
0	IRQ1_CAUSE — R/W. The state of this bit is logically ANDed with the IRQ1 signal as received by the ICH4's SERIRQ logic. This bit must be a 1 (default) if the ICH4 is expected to receive IRQ1 assertions from a SERIRQ device.

9.10 General Purpose I/O Registers (D31:F0)

The control for the general purpose I/O signals is handled through a separate 64-byte I/O space. The base offset for this space is selected by the GPIO_BAR register. Table 9-12 shows the GPIO Register I/O address map.

Table 9-12. Registers to Control GPIO

Offset	Mnemonic	Register Name	Default	Access
General Registers				
00–03h	GPIO_USE_SEL	GPIO Use Select	1A003180h	R/W
04–07h	GP_IO_SEL	GPIO Input/Output Select	0000 FFFFh	R/W
08–0Bh	—	Reserved	00h	RO
0C–0Fh	GP_LVL	GPIO Level for Input or Output	1F1F 0000h	R/W
10–13h	—	Reserved	00h	RO
Output Control Registers				
14–17h	GPO_TTL	GPIO TTL Select	06630000h	RO
18–1Bh	GPO_BLINK	GPIO Blink Enable	00000000h	R/W
1C–1Fh	—	Reserved	0	RO
Input Control Registers				
20–2Bh	—	Reserved	00000000h	RO
2C–2Fh	GPI_INV	GPIO Signal Invert	00000000h	R/W
30–33h	GPIO_USE_SEL2	GPIO Use Select	00000000h	R/W
34–37h	GP_IO_SEL2	GPIO Input/Output Select 2	00000000h	R/W
38–3Bh	GP_LVL2	GPIO Level for Input or Output 2	0000FFFFh	R/W

9.10.1 GPIO_USE_SEL—GPIO Use Select Register

Offset Address: GPIOBASE + 00h Attribute: R/W
 Default Value: 1A003180h Size: 32-bit
 Lockable: Yes Power Well: Resume

Bit	Description
21,11,5:0	<p>GPIO_USE_SEL — R/W. Each bit in this register enables the corresponding GPIO (if it exists) to be used as a GPIO, rather than for the native function.</p> <p>0 = Signal used as native function. 1 = Signal used as a GPIO.</p> <p>NOTES:</p> <p>1. Bits 31:29, 26, 15:14, and 10:9 are not implemented because there is no corresponding GPIO. Bits 28:27, 25:22, 20:18, 13:12, and 8:6 are not implemented because the corresponding GPIOs are not multiplexed. Bits 16:17 are not implemented because the GPIO selection is controlled by bits 0:1. The REQ/GNT# pairs are enabled/disabled together. For example, if bit 0 is set to 1, then the REQ/GNT[A]# pair will function as GPIO[0] and GPIO[16].</p>

9.10.2 GP_IO_SEL—GPIO Input/Output Select Register

Offset Address:	GPIOBASE +04h	Attribute:	R/W
Default Value:	0000FFFFh	Size:	32-bit
Lockable:	No	Power Well:	Resume

Bit	Description
31:29, 26	Reserved
28:27 25:24	GPIO[n]_SEL — R/W. 0 = Output. The corresponding GPIO signal is an output. 1 = Input. The corresponding GPIO signal is an input.
23:16	Always 0. The GPIOs are fixed as outputs.
15:0	Always 1. These GPIOs are fixed as inputs.

9.10.3 GP_LVL—GPIO Level for Input or Output Register

Offset Address:	GPIOBASE +0Ch	Attribute:	R/W, RO
Default Value:	1B3F 0000h	Size:	32-bit
Lockable:	No	Power Well:	See bit descriptions

Bit	Description
31:29, 26	Reserved
28:27, 25:24	GP_LVL[n] — R/W. If GPIO[n] is programmed to be an output (via the corresponding bit in the GP_IO_SEL register) then the bit can be updated by software to drive a high or low value on the output pin. If GPIO[n] is programmed as an input, then software can read the bit to determine the level on the corresponding input pin. These bits correspond to GPIO that are in the Resume well, and will be reset to their default values by RSMRST# and also by a write to the CF9h register. 0 = Low 1 = High
23:16	GP_LVL[n] — R/W. These bits can be updated by software to drive a high or low value on the output pin. These bits correspond to GPIO that are in the core well, and will be reset to their default values by PCIRST#. 0 = Low 1 = High
15:0	Reserved. GPI[13:11], and [8:0] the active status of a GPI is read from the corresponding bit in GPE0_STS register.

9.10.4 GPO_BLINK—GPO Blink Enable Register

Offset Address: GPIOBASE +18h Attribute: R/W
 Default Value: 0004 0000h Size: 32-bit
 Lockable: No Power Well: See bit description

Bit	Description
31:29, 26, 24:20, 17:0	Reserved
28:27, 25	<p>GP_BLINK[n] — R/W. The setting of these bits will have no effect if the corresponding GPIO is programmed as an input. These bits correspond to GPIO that are in the Resume well, and will be reset to their default values by RSMRST# or a write to the CF9h register.</p> <p>0 = The corresponding GPIO will function normally.</p> <p>1 = If the corresponding GPIO is programmed as an output, the output signal will blink at a rate of approximately once per second. The high and low times have approximately 0.5 seconds each. The GP_LVL bit is not altered when this bit is set.</p>
19:18	<p>GP_BLINK[n] — R/W. The setting of these bits will have no effect if the corresponding GPIO is programmed as an input. These bits correspond to GPIO that are in the Core well, and will be reset to their default values by PCIRST#.</p> <p>0 = The corresponding GPIO will function normally.</p> <p>1 = If the corresponding GPIO is programmed as an output, the output signal will blink at a rate of approximately once per second. The high and low times are approximately 0.5 seconds each. The GP_LVL bit is not altered when this bit is set.</p>

NOTE: GPIO[18] will blink by default immediately after reset. This signal could be connected to an LED to indicate a failed boot (by programming BIOS to clear GP_BLINK[18] after successful POST).

9.10.5 GPI_INV—GPIO Signal Invert Register

Offset Address:	GPIOBASE +2Ch	Attribute:	R/W
Default Value:	00000000h	Size:	32-bit
Lockable:	No	Power Well:	See bit description

Bit	Description
31:14, 10:9	Reserved
13:11, 8	<p>GP_INV[n] — R/W. These bits are used to allow both active-low and active-high inputs to cause SMI# or SCI. Note that in the S0 or S1 state, the input signal must be active for at least 2 PCI clocks to ensure detection by the Intel® ICH4. In the S3, S4 or S5 states the input signal must be active for at least 2 RTC clocks to ensure detection. The setting of these bits will have no effect if the corresponding GPIO is programmed as an output. These bits correspond to GPIO that are in the Resume well, and will be reset to their default values by RSMRST# or a write to the CF9h register.</p> <p>0 = The corresponding GPI_STS bit will be set when the ICH4 detects the state of the input pin to be high.</p> <p>1 = The corresponding GPI_STS bit will be set when the ICH4 detects the state of the input pin to be low.</p>
7:0	<p>GP_INV[n] — R/W. These bits are used to allow both active-low and active-high inputs to cause SMI# or SCI. Note that in the S0 or S1 state, the input signal must be active for at least 2 PCI clocks to ensure detection by the ICH4. The setting of these bits will have no effect if the corresponding GPIO is programmed as an output. These bits correspond to GPIO that are in the Core well, and will be reset to their default values by PCIRST#.</p> <p>0 = The corresponding GPI_STS bit will be set when the ICH4 detects the state of the input pin to be high.</p> <p>1 = The corresponding GPI_STS bit will be set when the ICH4 detects the state of the input pin to be low.</p>

9.10.6 GPIO_USE_SEL2—GPIO Use Select 2 Register

Offset Address:	GPIOBASE +30h	Attribute:	R/W
Default Value:	0000FFFh	Size:	32-bit
Lockable:	No	Power Well:	Core

Bit	Description
31:0	<p>GPIO_USE_SEL2[43:32]— R/W. Each bit in this register enables the corresponding GPIO (if it exists) to be used as a GPIO, rather than for the native function.</p> <p>0 = Signal used as native function.</p> <p>1 = Signal used as a GPIO.</p> <p>NOTES:</p> <ol style="list-style-type: none"> The following bits are not implemented because there is no corresponding GPIO: 31:12 If GPIO[n] does not exist, then the bit in this register will always read as 0 and writes will have no effect. <p>After a full reset (RSMRST#) all multiplexed signals in the resume and core wells are configured as their native function rather than as a GPIO. After just a PCIRST#, the GPIO in the core well are configured as their native function.</p>

9.10.7 GP_IO_SEL2—GPIO Input/Output Select 2 Register

Offset Address: GPIOBASE +34h Attribute: R/W
 Default Value: 00000000h Size: 32-bit
 Lockable: No Power Well: Core

Bit	Description
31:12	Always 0. No corresponding GPIO.
11:0	GP_IO_SEL2[43:32] — R/W. When set to a 1, the corresponding GPIO signal (if enabled in the GPIO_USE_SEL2 register) is programmed as an input. When set to 0, the GPIO signal is programmed as an output.

9.10.8 GP_LVL2—GPIO Level for Input or Output 2 Register

Offset Address: GPIOBASE +38h Attribute: R/W
 Default Value: 0000FFFh Size: 32-bit
 Lockable: No Power Well: See below

Bit	Description
31:12	Reserved. Read-only 0
11:0	GP_LVL2[43:32] — R/W. If GPIO[n] is programmed to be an output (via the corresponding bit in the GP_IO_SEL2 register), then the corresponding GP_LVL2[n] bit can be updated by software to drive a high or low value on the output pin. 1 = high, 0 = low. If GPIO[n] is programmed as an input, then the corresponding GP_LVL2 bit reflects the state of the input signal (1 = high, 0 = low). Writes will have no effect. Since these bits correspond to GPIO that are in the core well, these bits will be reset by PCIRST#.

IDE Controller Registers (D31:F1) 10

10.1 PCI Configuration Registers (IDE—D31:F1)

Note: Registers that are not shown should be treated as Reserved (See Section 6.2 for details).

All of the IDE registers are in the core well. None can be locked.

Table 10-1. PCI Configuration Register Address Map (IDE—D31:F1)

Offset	Mnemonic	Register Name	Default	Type
00–01h	VID	Vendor ID	8086h	RO
02–03h	DID	Device ID	24CBh	RO
04–05h	CMD	Command Register	00h	R/W, RO
06–07h	STS	Device Status	0280h	R/WC, RO
08h	RID	Revision ID	See Note 2	RO
09h	PI	Programming Interface	8Ah	RO
0Ah	SCC	Sub Class Code	01h	RO
0Bh	BCC	Base Class Code	01h	RO
0Dh	MLT	Master Latency Timer (Note 1)	00	RO
0Eh	HTYPE	Header Type	00h	RO
10–13h	PCMD_BAR	Primary Command Block Base Address	00000001h	R/W
14–17h	PCNL_BAR	Primary Control Block Base Address	00000001h	R/W
18–1Bh	SCMD_BAR	Secondary Command Block Base Address	00000001h	R/W
1C–1Fh	SCNL_BAR	Secondary Control Block Base Address	00000001h	R/W
20–23h	BAR	Base Address Register	00000001h	R/W
24–27h	EXBAR	Expansion BAR	00h	R/W
2C–2Dh	SVID	Subsystem Vendor ID	00	R/WO
2E–2Fh	SID	Subsystem ID	00	R/WO
3C	INTR_LN	Interrupt Line	00	R/W
3D	INTR_PN	Interrupt Pin	01	R/W
40–41h	IDE_TIMP	Primary IDE Timing	0000h	R/W
42–43h	ID_TIMS	Secondary IDE Timing	0000h	R/W
44h	SIDETIM	Slave IDE Timing	00h	R/W
48h	SDMAC	Synchronous DMA Control Register	00h	R/W
4A–4Bh	SDMATIM	Synchronous DMA Timing Register	0000h	R/W
54h	IDE_CONFIG	IDE I/O Configuration Register	00h	R/W

NOTES:

1. The ICH4 IDE controller is not arbitrated as a PCI device, therefore it does not need a master latency timer.
2. Refer to the ICH4 Specification Update for the value of the Revision ID Register.

10.1.1 VID—Vendor ID Register (LPC I/F—D31:F1)

Offset Address:	00–01h	Attribute:	RO
Default Value:	8086h	Size:	16 bit
Lockable:	No	Power Well:	Core

Bit	Description
15:0	Vendor Identification Value — RO. This is a 16-bit value assigned to Intel. Intel VID = 8086h

10.1.2 DID—Device ID Register (LPC I/F—D31:F1)

Offset Address:	02–03h	Attribute:	RO
Default Value:	24CBh	Size:	16 bit
Lockable:	No	Power Well:	Core

Bit	Description
15:0	Device Identification Value — RO. This is a 16-bit value assigned to the ICH4 IDE controller.

10.1.3 CMD — Command Register (IDE—D31:F1)

Address Offset:	04h–05h	Attribute:	R/W, RO
Default Value:	00h	Size:	16 bits

Bit	Description
15:10	Reserved
9	Fast Back to Back Enable (FBE) — RO. Reserved as 0.
8	SERR# Enable (SERR_EN) — RO. Reserved as 0.
7	Wait Cycle Control (WCC) — RO. Reserved as 0.
6	Parity Error Response (PER) — RO. Reserved as 0.
5	VGA Palette Snoop (VPS) — RO. Reserved as 0.
4	Postable Memory Write Enable (PMWE) — RO. Reserved as 0.
3	Special Cycle Enable (SCE) — RO. Reserved as 0.
2	Bus Master Enable (BME) — R/W. Controls the ICH4's ability to act as a PCI master for IDE Bus Master transfers. 0 = Disable 1 = Enable
1	Memory Space Enable (MSE) — R/W. 0 = Disables access. 1 = Enables access to the IDE Expansion memory range. The EXBAR register (Offset 24h) must be programmed before this bit is set. NOTE: BIOS should set this bit to a 1.

10.1.6 PI — Programming Interface Register (IDE—D31:F1)

Address Offset: 09h Attribute: R/W
 Default Value: 8Ah Size: 8 bits

Bit	Description
7	This read-only bit is a 1 to indicate that the ICH4 supports bus master operation
6:4	Reserved. Will always return 0.
3	SOP_MODE_CAP — RO. This read-only bit is a 1 to indicate that the secondary controller supports both legacy and native modes.
2	SOP_MODE_SEL — R/W. This read/write bit determines the mode that the secondary IDE channel is operating in. 0 = Legacy-PCI mode (default) 1 = Native-PCI mode
1	POP_MODE_CAP — RO. This read-only bit is a 1 to indicate that the primary controller supports both legacy and native modes.
0	POP_MODE_SEL — R/W. This read/write bit determines the mode that the primary IDE channel is operating in. 0 = Legacy-PCI mode (default) 1 = Native-PCI mode

10.1.7 SCC — Sub Class Code Register (IDE—D31:F1)

Address Offset: 0Ah Attribute: RO
 Default Value: 01h Size: 8 bits

Bit	Description
7:0	Sub Class Code — RO. 01h = IDE device, in the context of a mass storage device.

10.1.8 BCC — Base Class Code Register (IDE—D31:F1)

Address Offset: 0Bh Attribute: RO
 Default Value: 01h Size: 8 bits

Bit	Description
7:0	Base Class Code — RO. 01 = Mass storage device

10.1.12 SCMD_BAR—Secondary Command Block Base Address Register (IDE D31:F1)

Address Offset: 18h–1Bh Attribute: R/W
 Default Value: 00000001h Size: 32 bits

Bit	Description
31:16	Reserved
15:3	Base Address — R/W. Base address of the I/O space (8 consecutive I/O locations).
2:1	Reserved
0	Resource Type Indicator (RTE) — RO. This bit is set to one, indicating a request for I/O space.

NOTE: This 4-byte I/O space is used in native mode for the Secondary controller's Command Block.

10.1.13 SCNL_BAR—Secondary Control Block Base Address Register (IDE D31:F1)

Address Offset: 1Ch–1Fh Attribute: R/W
 Default Value: 00000001h Size: 32 bits

Bit	Description
31:16	Reserved
15:2	Base Address — R/W. Base address of the I/O space (4 consecutive I/O locations).
1	Reserved
0	Resource Type Indicator (RTE) — RO. This bit is set to one, indicating a request for I/O space.

NOTE: This 4-byte I/O space is used in native mode for the Secondary controller's Command Block.

10.1.14 BM_BASE — Bus Master Base Address Register (IDE—D31:F1)

Address Offset: 20h–23h Attribute: R/W
 Default Value: 00000001h Size: 32 bits

The Bus Master IDE interface function uses Base Address register 5 to request a 16-byte I/O space to provide a software interface to the Bus Master functions. Only 12 bytes are actually used (6 bytes for primary, 6 bytes for secondary). Only bits [15:4] are used to decode the address.

Bit	Description
31:16	Reserved
15:4	Base Address — R/W. Base address of the I/O space (16 consecutive I/O locations).
3:1	Reserved
0	Resource Type Indicator (RTE) — RO. Hardwired to 1, indicating a request for I/O space.

Bit	Description
11:10	Reserved
9:8	Recovery Time (RCT) — R/W. The setting of these bits determines the minimum number of PCI clocks between the last IORDY sample point and the IOR#/IOW# strobe of the next cycle. 00 = 4 clocks 01 = 3 clocks 10 = 2 clocks 11 = 1 clock
7	Drive 1 DMA Timing Enable (DTE1) — R/W. 0 = Disable. 1 = Enable the fast timing mode for DMA transfers only for this drive. PIO transfers to the IDE data port will run in compatible timing.
6	Drive 1 Prefetch/Posting Enable (PPE1) — R/W. 0 = Disable. 1 = Enable Prefetch and posting to the IDE data port for this drive.
5	Drive 1 IORDY Sample Point Enable (IE1) — R/W. 0 = Disable IORDY sampling for this drive. 1 = Enable IORDY sampling for this drive.
4	Drive 1 Fast Timing Bank (TIME1) — R/W. 0 = Accesses to the data port will use compatible timings for this drive. 1 = When this bit = 1 and bit 14 = 0, accesses to the data port will use bits 13:12 for the IORDY sample point, and bits 9:8 for the recovery time. When this bit = 1 and bit 14 = 1, accesses to the data port will use the IORDY sample point and recover time specified in the slave IDE timing register.
3	Drive 0 DMA Timing Enable (DTE0) — R/W. 0 = Disable 1 = Enable fast timing mode for DMA transfers only for this drive. PIO transfers to the IDE data port will run in compatible timing.
2	Drive 0 Prefetch/Posting Enable (PPE0) — R/W. 0 = Disable prefetch and posting to the IDE data port for this drive. 1 = Enable prefetch and posting to the IDE data port for this drive.
1	Drive 0 IORDY Sample Point Enable (IE0) — R/W. 0 = Disable IORDY sampling is disabled for this drive. 1 = Enable IORDY sampling for this drive.
0	Drive 0 Fast Timing Bank (TIME0) — R/W. 0 = Accesses to the data port will use compatible timings for this drive. 1 = Accesses to the data port will use bits 13:12 for the IORDY sample point, and bits 9:8 for the recovery time.

10.1.21 SLV_IDETIM—Slave (Drive 1) IDE Timing Register (IDE—D31:F1)

Address Offset: 44h
Default Value: 00h

Attribute: R/W
Size: 8 bits

Bit	Description
7:6	<p>Secondary Drive 1 IORDY Sample Point (SISP1) — R/W. This field determines the number of PCI clocks between IDE IOR#/IOW# assertion and the first IORDY sample point, if the access is to drive 1 data port and bit 14 of the IDE timing register for secondary is set.</p> <p>00 = 5 clocks 01 = 4 clocks 10 = 3 clocks 11 = Reserved</p>
5:4	<p>Secondary Drive 1 Recovery Time (SRCT1) — R/W. This field determines the minimum number of PCI clocks between the last IORDY sample point and the IOR#/IOW# strobe of the next cycle, if the access is to drive 1 data port and bit 14 of the IDE Timing (IDE_TIM) register for secondary is set.</p> <p>00 = 4 clocks 01 = 3 clocks 10 = 2 clocks 11 = 1 clocks</p>
3:2	<p>Primary Drive 1 IORDY Sample Point (PISP1) — R/W. This field determines the number of PCI clocks between IOR#/IOW# assertion and the first IORDY sample point, if the access is to drive 1 data port and bit 14 of the IDE timing register for primary is set.</p> <p>00 = 5 clocks 01 = 4 clocks 10 = 3 clocks 11 = Reserved</p>
1:0	<p>Primary Drive 1 Recovery Time (PRCT1) — R/W. This field determines the minimum number of PCI clocks between the last IORDY sample point and the IOR#/IOW# strobe of the next cycle, if the access is to drive 1 data port and bit 14 of the IDE timing register for primary is set.</p> <p>00 = 4 clocks 01 = 3 clocks 10 = 2 clocks 11 = 1 clocks</p>

10.1.22 SDMA_CNT—Synchronous DMA Control Register (IDE—D31:F1)

Address Offset: 48h
 Default Value: 00h

Attribute: R/W
 Size: 8 bits

Bit	Description
7:4	Reserved
3	Secondary Drive 1 Synchronous DMA Mode Enable (SSDE1) — R/W. 0 = Disable (default) 1 = Enable Synchronous DMA mode for secondary channel drive 1.
2	Secondary Drive 0 Synchronous DMA Mode Enable (SSDE0) — R/W. 0 = Disable (default) 1 = Enable Synchronous DMA mode for secondary drive 0.
1	Primary Drive 1 Synchronous DMA Mode Enable (PSDE1) — R/W. 0 = Disable (default) 1 = Enable Synchronous DMA mode for primary channel drive 1.
0	Primary Drive 0 Synchronous DMA Mode Enable (PSDE0) — R/W. 0 = Disable (default) 1 = Enable Synchronous DMA mode for primary channel drive 0.

10.1.23 SDMA_TIM—Synchronous DMA Timing Register (IDE—D31:F1)

Address Offset: 4A–4Bh
Default Value: 0000h

Attribute: R/W
Size: 16 bits

Note: For FAST_SCB1=1 (133 MHz clk) in bits [13:12, 9:8, 5:4, 1:0], refer to [Section 5.15.6](#) for details.

Bit	Description															
15:14	Reserved															
13:12	<p>Secondary Drive 1 Cycle Time (SCT1) — R/W. For Ultra ATA mode. The setting of these bits determines the minimum write strobe cycle time (CT). The DMARDY#-to-STOP (RP) time is also determined by the setting of these bits.</p> <table> <tr> <td>SCB1 = 0 (33 MHz clk)</td> <td>SCB1 = 1 (66 MHz clk)</td> <td>FAST_SCB1 = 1 (133 MHz clk)</td> </tr> <tr> <td>00 = CT 4 clocks, RP 6 clocks</td> <td>00 = Reserved</td> <td>00 = Reserved</td> </tr> <tr> <td>01 = CT 3 clocks, RP 5 clocks</td> <td>01 = CT 3 clocks, RP 8 clocks</td> <td>01 = CT 3 clks, RP 16 clks</td> </tr> <tr> <td>10 = CT 2 clocks, RP 4 clocks</td> <td>10 = CT 2 clocks, RP 8 clocks</td> <td>10 = Reserved</td> </tr> <tr> <td>11 = Reserved</td> <td>11 = Reserved</td> <td>11 = Reserved</td> </tr> </table>	SCB1 = 0 (33 MHz clk)	SCB1 = 1 (66 MHz clk)	FAST_SCB1 = 1 (133 MHz clk)	00 = CT 4 clocks, RP 6 clocks	00 = Reserved	00 = Reserved	01 = CT 3 clocks, RP 5 clocks	01 = CT 3 clocks, RP 8 clocks	01 = CT 3 clks, RP 16 clks	10 = CT 2 clocks, RP 4 clocks	10 = CT 2 clocks, RP 8 clocks	10 = Reserved	11 = Reserved	11 = Reserved	11 = Reserved
SCB1 = 0 (33 MHz clk)	SCB1 = 1 (66 MHz clk)	FAST_SCB1 = 1 (133 MHz clk)														
00 = CT 4 clocks, RP 6 clocks	00 = Reserved	00 = Reserved														
01 = CT 3 clocks, RP 5 clocks	01 = CT 3 clocks, RP 8 clocks	01 = CT 3 clks, RP 16 clks														
10 = CT 2 clocks, RP 4 clocks	10 = CT 2 clocks, RP 8 clocks	10 = Reserved														
11 = Reserved	11 = Reserved	11 = Reserved														
11:10	Reserved															
9:8	<p>Secondary Drive 0 Cycle Time (SCT0) — R/W. For Ultra ATA mode. The setting of these bits determines the minimum write strobe cycle time (CT). The DMARDY#-to-STOP (RP) time is also determined by the setting of these bits.</p> <table> <tr> <td>SCB1 = 0 (33 MHz clk)</td> <td>SCB1 = 1 (66 MHz clk)</td> <td>FAST_SCB1 = 1 (133 MHz clk)</td> </tr> <tr> <td>00 = CT 4 clocks, RP 6 clocks</td> <td>00 = Reserved</td> <td>00 = Reserved</td> </tr> <tr> <td>01 = CT 3 clocks, RP 5 clocks</td> <td>01 = CT 3 clocks, RP 8 clocks</td> <td>01 = CT 3 clks, RP 16 clks</td> </tr> <tr> <td>10 = CT 2 clocks, RP 4 clocks</td> <td>10 = CT 2 clocks, RP 8 clocks</td> <td>10 = Reserved</td> </tr> <tr> <td>11 = Reserved</td> <td>11 = Reserved</td> <td>11 = Reserved</td> </tr> </table>	SCB1 = 0 (33 MHz clk)	SCB1 = 1 (66 MHz clk)	FAST_SCB1 = 1 (133 MHz clk)	00 = CT 4 clocks, RP 6 clocks	00 = Reserved	00 = Reserved	01 = CT 3 clocks, RP 5 clocks	01 = CT 3 clocks, RP 8 clocks	01 = CT 3 clks, RP 16 clks	10 = CT 2 clocks, RP 4 clocks	10 = CT 2 clocks, RP 8 clocks	10 = Reserved	11 = Reserved	11 = Reserved	11 = Reserved
SCB1 = 0 (33 MHz clk)	SCB1 = 1 (66 MHz clk)	FAST_SCB1 = 1 (133 MHz clk)														
00 = CT 4 clocks, RP 6 clocks	00 = Reserved	00 = Reserved														
01 = CT 3 clocks, RP 5 clocks	01 = CT 3 clocks, RP 8 clocks	01 = CT 3 clks, RP 16 clks														
10 = CT 2 clocks, RP 4 clocks	10 = CT 2 clocks, RP 8 clocks	10 = Reserved														
11 = Reserved	11 = Reserved	11 = Reserved														
7:6	Reserved															
5:4	<p>Primary Drive 1 Cycle Time (PCT1) — R/W. For Ultra ATA mode, the setting of these bits determines the minimum write strobe cycle time (CT). The DMARDY#-to-STOP (RP) time is also determined by the setting of these bits.</p> <table> <tr> <td>PCB1 = 0 (33 MHz clk)</td> <td>PCB1 = 1 (66 MHz clk)</td> <td>FAST_PCB1 = 1 (133 MHz clk)</td> </tr> <tr> <td>00 = CT 4 clocks, RP 6 clocks</td> <td>00 = Reserved</td> <td>00 = Reserved</td> </tr> <tr> <td>01 = CT 3 clocks, RP 5 clocks</td> <td>01 = CT 3 clocks, RP 8 clocks</td> <td>01 = CT 3 clks, RP 16 clks</td> </tr> <tr> <td>10 = CT 2 clocks, RP 4 clocks</td> <td>10 = CT 2 clocks, RP 8 clocks</td> <td>10 = Reserved</td> </tr> <tr> <td>11 = Reserved</td> <td>11 = Reserved</td> <td>11 = Reserved</td> </tr> </table>	PCB1 = 0 (33 MHz clk)	PCB1 = 1 (66 MHz clk)	FAST_PCB1 = 1 (133 MHz clk)	00 = CT 4 clocks, RP 6 clocks	00 = Reserved	00 = Reserved	01 = CT 3 clocks, RP 5 clocks	01 = CT 3 clocks, RP 8 clocks	01 = CT 3 clks, RP 16 clks	10 = CT 2 clocks, RP 4 clocks	10 = CT 2 clocks, RP 8 clocks	10 = Reserved	11 = Reserved	11 = Reserved	11 = Reserved
PCB1 = 0 (33 MHz clk)	PCB1 = 1 (66 MHz clk)	FAST_PCB1 = 1 (133 MHz clk)														
00 = CT 4 clocks, RP 6 clocks	00 = Reserved	00 = Reserved														
01 = CT 3 clocks, RP 5 clocks	01 = CT 3 clocks, RP 8 clocks	01 = CT 3 clks, RP 16 clks														
10 = CT 2 clocks, RP 4 clocks	10 = CT 2 clocks, RP 8 clocks	10 = Reserved														
11 = Reserved	11 = Reserved	11 = Reserved														
3:2	Reserved															
1:0	<p>Primary Drive 0 Cycle Time (PCT0) — R/W. For Ultra ATA mode, the setting of these bits determines the minimum write strobe cycle time (CT). The DMARDY#-to-STOP (RP) time is also determined by the setting of these bits.</p> <table> <tr> <td>PCB1 = 0 (33 MHz clk)</td> <td>PCB1 = 1 (66 MHz clk)</td> <td>FAST_PCB1 = 1 (133 MHz clk)</td> </tr> <tr> <td>00 = CT 4 clocks, RP 6 clocks</td> <td>00 = Reserved</td> <td>00 = Reserved</td> </tr> <tr> <td>01 = CT 3 clocks, RP 5 clocks</td> <td>01 = CT 3 clocks, RP 8 clocks</td> <td>01 = CT 3 clks, RP 16 clks</td> </tr> <tr> <td>10 = CT 2 clocks, RP 4 clocks</td> <td>10 = CT 2 clocks, RP 8 clocks</td> <td>10 = Reserved</td> </tr> <tr> <td>11 = Reserved</td> <td>11 = Reserved</td> <td>11 = Reserved</td> </tr> </table>	PCB1 = 0 (33 MHz clk)	PCB1 = 1 (66 MHz clk)	FAST_PCB1 = 1 (133 MHz clk)	00 = CT 4 clocks, RP 6 clocks	00 = Reserved	00 = Reserved	01 = CT 3 clocks, RP 5 clocks	01 = CT 3 clocks, RP 8 clocks	01 = CT 3 clks, RP 16 clks	10 = CT 2 clocks, RP 4 clocks	10 = CT 2 clocks, RP 8 clocks	10 = Reserved	11 = Reserved	11 = Reserved	11 = Reserved
PCB1 = 0 (33 MHz clk)	PCB1 = 1 (66 MHz clk)	FAST_PCB1 = 1 (133 MHz clk)														
00 = CT 4 clocks, RP 6 clocks	00 = Reserved	00 = Reserved														
01 = CT 3 clocks, RP 5 clocks	01 = CT 3 clocks, RP 8 clocks	01 = CT 3 clks, RP 16 clks														
10 = CT 2 clocks, RP 4 clocks	10 = CT 2 clocks, RP 8 clocks	10 = Reserved														
11 = Reserved	11 = Reserved	11 = Reserved														

10.1.24 IDE_CONFIG—IDE I/O Configuration Register (IDE—D31:F1)

Address Offset: 54h Attribute: R/W
 Default Value: 00h Size: 32 bits

Bit	Description
31:20	Reserved
19:18	SEC_SIG_MODE — R/W. These bits are used to control the mode of the Secondary IDE signal pins. If the SRS bit (bit 7, offset D5h of D31:F0) is 1, the reset states of bits 19:18 will be 01 (tri-state) instead of 00 (normal). 00 = Normal (Enabled) 01 = Tri-state (Disabled) 10 = Drive low (Disabled) 11 = Reserved
17:16	PRIM_SIG_MODE — R/W. These bits are used to control the mode of the Primary IDE signal pins. If the PRS bit (bit 6, offset D5h of D31:F0) is 1, then the reset states of bits 17:16 will be 01 (tri-state) instead of 00 (normal). 00 = Normal (Enabled) 01 = Tri-state (Disabled) 10 = Drive low (Disabled) 11 = Reserved
15	Fast Secondary Drive 1 Base Clock (FAST_SCB1) — R/W. This bit is used in conjunction with the SCT1 bits to enable/disable Ultra ATA/100 timings for the Secondary Slave drive. 0 = Disable Ultra ATA/100 timing for the Secondary Slave drive. 1 = Enable Ultra ATA/100 timing for the Secondary Slave drive (overrides bit 3 in this register).
14	Fast Secondary Drive 0 Base Clock (FAST_SCB0) — R/W. This bit is used in conjunction with the SCT0 bits to enable/disable Ultra ATA/100 timings for the Secondary Master drive. 0 = Disable Ultra ATA/100 timing for the Secondary Master drive. 1 = Enable Ultra ATA/100 timing for the Secondary Master drive (overrides bit 2 in this register).
13	Fast Primary Drive 1 Base Clock (FAST_PCB1) — R/W. This bit is used in conjunction with the PCT1 bits to enable/disable Ultra ATA/100 timings for the Primary Slave drive. 0 = Disable Ultra ATA/100 timing for the Primary Slave drive. 1 = Enable Ultra ATA/100 timing for the Primary Slave drive (overrides bit 1 in this register).
12	Fast Primary Drive 0 Base Clock (FAST_PCB0) — R/W. This bit is used in conjunction with the PCT0 bits to enable/disable Ultra ATA/100 timings for the Primary Master drive. 0 = Disable Ultra ATA/100 timing for the Primary Master drive. 1 = Enable Ultra ATA/100 timing for the Primary Master drive (overrides bit 0 in this register).
11	Reserved
10	WR_PingPong_EN — R/W. 0 = Disabled. The buffer behaves similar to PIIX4. 1 = Enables the write buffer to be used in a split (ping/pong) manner.
9: 8	Reserved
7	Secondary Slave Channel Cable Reporting — R/W. BIOS should program this bit to tell the IDE driver which cable is plugged into the channel. 0 = 40 conductor cable is present. 1 = 80 conductor cable is present.
6	Secondary Master Channel Cable Reporting — R/W. Same description as bit 7

Bit	Description
5	Primary Slave Channel Cable Reporting — R/W. Same description as bit 7
4	Primary Master Channel Cable Reporting — R/W. Same description as bit 7
3	Secondary Drive 1 Base Clock (SCB1) — R/W. 0 = 33 MHz base clock for Ultra ATA timings. 1 = 66 MHz base clock for Ultra ATA timings.
2	Secondary Drive 0 Base Clock (SCB0) — R/W. 0 = 33 MHz base clock for Ultra ATA timings. 1 = 66 MHz base clock for Ultra ATA timings.
1	Primary Drive 1 Base Clock (PCB1) — R/W. 0 = 33 MHz base clock for Ultra ATA timings. 1 = 66 MHz base clock for Ultra ATA timings.
0	Primary Drive 0 Base Clock (PCB0) — R/W. 0 = 33 MHz base clock for Ultra ATA timings. 1 = 66 MHz base clock for Ultra ATA timings.

10.2 Bus Master IDE I/O Registers (D31:F1)

The bus master IDE function uses 16 bytes of I/O space, allocated via the BMIBA register, located in Device 31:Function 1 Configuration space, offset 20h. All bus master IDE I/O space registers can be accessed as byte, word, or DWord quantities. Reading reserved bits returns an indeterminate, inconsistent value, and writes to reserved bits have no affect (but should not be attempted). The description of the I/O registers is shown below in [Table 10-2](#).

Table 10-2. Bus Master IDE I/O Registers

Offset	Mnemonic	Register Name	Default	Type
00	BMICP	Bus Master IDE Command Primary	00h	R/W
01		Reserved	00h	RO
02	BMISP	Bus Master IDE Status Primary	00h	R/WC, R/W, RO
03		Reserved	00h	RO
04–07	BMIDP	Bus Master IDE Descriptor Table Pointer Primary	xxxxxxxh	R/W
08	BMICS	Bus Master IDE Command Secondary	00h	R/W
09		Reserved	00h	RO
0A	BMISS	Bus Master IDE Status Secondary	00h	R/WC, R/W, RO
0B		Reserved	00h	RO
0C–0F	BMIDS	Bus Master IDE Descriptor Table Pointer Secondary	xxxxxxxh	R/W

10.2.2 BMIS[P,S]—Bus Master IDE Status Register

Address Offset: Primary: 02h Attribute: R/WC, R/W, RO
 Secondary: 0Ah
 Default Value: 00h Size: 8 bits

Bit	Description
7	Reserved. Returns 0.
6	Drive 1 DMA Capable — R/W. 0 = Not Capable. 1 = Capable. Set by device dependent code (BIOS or device driver) to indicate that drive 1 for this channel is capable of DMA transfers, and that the controller has been initialized for optimum performance. The ICH4 does not use this bit. It is intended for systems that do not attach BMIDE to the PCI bus.
5	Drive 0 DMA Capable — R/W. 0 = Not Capable 1 = Capable. Set by device dependent code (BIOS or device driver) to indicate that drive 0 for this channel is capable of DMA transfers, and that the controller has been initialized for optimum performance. The ICH4 does not use this bit. It is intended for systems that do not attach BMIDE to the PCI bus.
4:3	Reserved. Returns 0s.
2	Interrupt — R/WC. Software can use this bit to determine if an IDE device has asserted its interrupt line (IRQ 14 for the Primary channel, and IRQ 15 for Secondary). 0 = This bit is cleared by software writing a 1 to the bit position. If this bit is cleared while the interrupt is still active, this bit will remain clear until another assertion edge is detected on the interrupt line. 1 = Set by the rising edge of the IDE interrupt line, regardless of whether or not the interrupt is masked in the 8259 or the internal I/O APIC. When this bit is read as a 1, all data transferred from the drive is visible in system memory.
1	Error — R/WC. 0 = This bit is cleared by software writing a 1 to the bit position. 1 = This bit is set when the controller encounters a target abort or master abort when transferring data on PCI.
0	Bus Master IDE Active (ACT) — RO. 0 = This bit is cleared by the ICH4 when the last transfer for a region is performed, where EOT for that region is set in the region descriptor. It is also cleared by the ICH4 when the Start bit is cleared in the Command register. When this bit is read as a 0, all data transferred from the drive during the previous bus master command is visible in system memory, unless the bus master command was aborted. 1 = Set by the ICH4 when the Start bit is written to the Command register.

10.2.3 BMID[P,S]—Bus Master IDE Descriptor Table Pointer Register

Address Offset: Primary: 04h Attribute: R/W
 Secondary: 0Ch
 Default Value: All bits undefined Size: 32 bits

Bit	Description
31:2	Address of Descriptor Table (ADDR) — R/W. Corresponds to A[31:2]. The Descriptor Table must be DWord-aligned. The Descriptor Table must not cross a 64-KB boundary in memory.
1:0	Reserved

USB UHCI Controllers Registers 11

11.1 PCI Configuration Registers (D29:F0/F1/F2)

Note: Address locations not shown in Table 11-1 should be treated as Reserved (see Section 6.2 for details).

Table 11-1. PCI Configuration Register Address Map (USB—D29:F0/F1/F2)

Offset	Mnemonic	Register Name	Function 0 Default	Function 1 Default	Function 2 Default	Type
00–01h	VID	Vendor ID	8086h	8086h	8086h	RO
02–03h	DID	Device ID	24C2h	24C4h	24C7h	RO
04–05h	CMD	Command Register	0000h	0000h	0000h	R/W, RO
06–07h	STA	Device Status	0280h	0280h	0280h	R/WC, RO
08h	RID	Revision ID	See Note	See Note	See Note	RO
09h	PI	Programming Interface	00h	00h	00h	RO
0Ah	SCC	Sub Class Code	03h	03h	03h	RO
0Bh	BCC	Base Class Code	0Ch	0Ch	0Ch	RO
0Eh	HTYPE	Header Type	80h	00h	00h	RO
20–23h	Base	Base Address Register	00000001h	00000001h	00000001h	R/W, RO
2C–2Dh	SVID	Subsystem Vendor ID	00	00	00	RO
2E–2Fh	SID	Subsystem ID	00	00	00	RO
3Ch	INTR_LN	Interrupt Line	00h	00h	00h	R/W
3Dh	INTR_PN	Interrupt Pin	01h	02h	03h	RO
60h	SB_RELNUM	USB Release Number	10h	10	10	RO
C0–C1h	USB_LEGKEY	USB Legacy Keyboard/Mouse Control	2000h	2000h	2000h	R/W, R/WC, RO
C4h	USB_RES	USB Resume Enable	00h	00h	00h	R/W

NOTE: Refer to the ICH4 Specification Update for the value of the Revision ID Register.

11.1.1 VID—Vendor Identification Register (USB—D29:F0/F1/F2)

Address Offset: 00–01h Attribute: RO
 Default Value: 8086h Size: 16 bits

Bit	Description
15:0	Vendor Identification Value — RO. This is a 16-bit value assigned to Intel

11.1.2 DID—Device Identification Register (USB—D29:F0/F1/F2)

Address Offset: 02–03h Attribute: RO
 Default Value: Function 0: 24C2h Size: 16 bits
 Function 1: 24C4h
 Function 2: 24C7h

Bit	Description
15:0	Device Identification Value — RO. This is a 16-bit value assigned to the ICH4 USB Host controllers.

11.1.3 CMD—Command Register (USB—D29:F0/F1/F2)

Address Offset: 04–05h Attribute: R/W, RO
 Default Value: 0000h Size: 16 bits

Bit	Description
15:10	Reserved
9	Fast Back to Back Enable (FBE) — RO. Reserved as 0.
8	SERR# Enable (SERR_EN) — RO. Reserved as 0.
7	Wait Cycle Control (WCC) — RO. Reserved as 0.
6	Parity Error Response (PER) — RO. Reserved as 0.
5	VGA Palette Snoop (VSP) — RO. Reserved as 0.
4	Postable Memory Write Enable (PMWE) — RO. Reserved as 0.
3	Special Cycle Enable (SCE) — RO. Reserved as 0.
2	Bus Master Enable (BME) — RW. When set, the ICH4 can act as a master on the PCI bus for USB transfers.
1	Memory Space Enable (MSE) — RO. Reserved as 0.
0	I/O Space Enable (IOSE) — RW. This bit controls access to the I/O space registers. 0 = Disable 1 = Enable accesses to the USB I/O registers. The Base Address register for USB should be programmed before this bit is set.

11.1.4 STA—Device Status Register (USB—D29:F0/F1/F2)

Address Offset: 06–07h Attribute: R/WC, RO
 Default Value: 0280h Size: 16 bits

Bit	Description
15:14	Reserved as 00b. Read Only.
13	Received Master Abort (RMA) — R/WC. 0 = Software clears this bit by writing a 1 to the bit location. 1 = USB, as a master, generated a master-abort.
12	Reserved. Always read as 0.
11	Signaled Target Abort (STA) — R/WC. 0 = Software clears this bit by writing a 1 to the bit location. 1 = USB function is targeted with a transaction that the ICH4 terminates with a target abort.
10:9	DEVSEL# Timing Status (DEV_STS) — RO: This 2-bit field defines the timing for DEVSEL# assertion. These read only bits indicate the ICH4's DEVSEL# timing when performing a positive decode. ICH4 generates DEVSEL# with medium timing for USB.
8	Data Parity Error Detected (DPED) — RO. Reserved as 0.
7	Fast Back to Back Capable (FB2BC) — RO. Reserved as 1.
6	User Definable Features (UDF) — RO. Reserved as 0.
5	66 MHz Capable (66MHZ_CAP) — RO. Reserved as 0.
4:0	Reserved

11.1.5 RID—Revision Identification Register (USB—D29:F0/F1/F2)

Address Offset: 08h Attribute: RO
 Default Value: See Bit Description Size: 8 bits

Bit	Description
7:0	Revision Identification Value — RO. Refer to the ICH4 specification update for the value of the Revision ID Register.

11.1.6 PI—Programming Interface (USB—D29:F0/F1/F2)

Address Offset: 09h Attribute: RO
 Default Value: 00h Size: 8 bits

Bit	Description
7:0	Programming Interface — RO. 00h = No specific register level programming interface defined.

11.1.10 BASE—Base Address Register (USB—D29:F0/F1/F2)

Address Offset: 20–23h Attribute: R/W, RO
 Default Value: 00000001h Size: 32 bits

Bit	Description
31:16	Reserved
15:5	Base Address — R/W. Bits [15:5] correspond to I/O address signals AD [15:5], respectively. This gives 32 bytes of relocatable I/O space.
4:1	Reserved
0	Resource Type Indicator (RTE) — RO. This bit is hardwired to 1 indicating that the base address field in this register maps to I/O space

11.1.11 SVID — Subsystem Vendor ID (USB—D29:F0/F1/F2)

Address Offset: 2Ch–2Dh Attribute: RO
 Default Value: 00h Size: 16 bits
 Lockable: No Power Well: Core

Bit	Description
15:0	Subsystem Vendor ID (SVID) — RO. The SVID register, in combination with the Subsystem ID (SID) register, enables the operating system (OS) to distinguish subsystems from each other. The value returned by reads to this register is the same as what was written by BIOS into the IDE_SVID register.

11.1.12 SID — Subsystem ID (USB—D29:F0/F1/F2)

Address Offset: 2Eh–2Fh Attribute: RO
 Default Value: 00h Size: 16 bits
 Lockable: No Power Well: Core

Bit	Description
15:0	Subsystem ID (SID) — R/Write-Once. The SID register, in combination with the SVID register, enables the operating system (OS) to distinguish subsystems from each other. The value returned by reads to this register is the same as what was written by BIOS into the IDE_SID register.

11.1.16 USB_LEGKEY—USB Legacy Keyboard/Mouse Control Register (USB—D29:F0/F1/F2)

Address Offset: C0–C1h Attribute: R/W, R/WC, RO
 Default Value: 2000h Size: 16 bits

This register is implemented separately in each of the USB UHCI functions. However, the enable and status bits for the trapping logic are OR'd and shared, respectively, since their functionality is not specific to any one host controller.

Bit	Description
15	SMI Caused by End of Pass-through (SMIBYENDPS) — R/WC. Indicates if the event occurred. Note that even if the corresponding enable bit is not set in bit 7, then this bit will still be active. It is up to the SMM code to use the enable bit to determine the exact cause of the SMI#. 0 = Software clears this bit by writing a 1 to the bit location in any of the controllers. 1 = Event Occurred
14	Reserved
13	PCI Interrupt Enable (USBPIRQEN) — R/W. Used to prevent the USB controller from generating an interrupt due to transactions on its ports. Note, when disabled, that it will probably be configured to generate an SMI using bit 4 of this register. Default to 1 for compatibility with older USB software. 0 = Disable 1 = Enable
12	SMI Caused by USB Interrupt (SMIBYUSB) — RO. Indicates if an interrupt event occurred from this controller. The interrupt from the controller is taken before the enable in bit 13 has any effect to create this read-only bit. Note that even if the corresponding enable bit is not set in the Bit 4, then this bit may still be active. It is up to the SMM code to use the enable bit to determine the exact cause of the SMI#. 0 = Software should clear the interrupts via the USB controllers. Writing a 1 to this bit will have no effect. 1 = Event Occurred.
11	SMI Caused by Port 64 Write (TRAPBY64W) — R/WC. Indicates if the event occurred. Note that even if the corresponding enable bit is not set in the bit 3, then this bit will still be active. It is up to the SMM code to use the enable bit to determine the exact cause of the SMI#. Note that the A20Gate Pass-Through Logic allows specific port 64h writes to complete without setting this bit. 0 = Software clears this bit by writing a 1 to the bit location in any of the controllers. 1 = Event Occurred.
10	SMI Caused by Port 64 Read (TRAPBY64R) — R/WC. Indicates if the event occurred. Note that even if the corresponding enable bit is not set in the bit 2, then this bit will still be active. It is up to the SMM code to use the enable bit to determine the exact cause of the SMI#. 0 = Software clears this bit by writing a 1 to the bit location in any of the controllers. 1 = Event Occurred.
9	SMI Caused by Port 60 Write (TRAPBY60W) — R/WC. Indicates if the event occurred. Note that even if the corresponding enable bit is not set in the bit 1, then this bit will still be active. It is up to the SMM code to use the enable bit to determine the exact cause of the SMI#. Note that the A20Gate Pass-Through Logic allows specific port 64h writes to complete without setting this bit. 0 = Software clears this bit by writing a 1 to the bit location in any of the controllers. 1 = Event Occurred.
8	SMI Caused by Port 60 Read (TRAPBY60R) — R/WC. Indicates if the event occurred. Note that even if the corresponding enable bit is not set in the bit 0, then this bit will still be active. It is up to the SMM code to use the enable bit to determine the exact cause of the SMI#. 0 = Software clears this bit by writing a 1 to the bit location in any of the controllers. 1 = Event Occurred.

Bit	Description
7	SMI at End of Pass-through Enable (SMIATENDPS) — R/W. May need to cause SMI at the end of a pass-through. Can occur if an SMI is generated in the middle of a pass through, and needs to be serviced later. 0 = Disable 1 = Enable
6	Pass Through State (PSTATE) — RO. 0 = If software needs to reset this bit, it should set bit 5 in all of the host controllers to 0. 1 = Indicates that the state machine is in the middle of an A20GATE pass-through sequence.
5	A20Gate Pass-Through Enable (A20PASSEN) — R/W. 0 = Disable. 1 = Allows A20GATE sequence Pass-Through function. A specific cycle sequence involving writes to port 60h and 64h does not result in the setting of the SMI status bits.
4	SMI on USB IRQ Enable (USBSMIEN) — R/W. 0 = Disable 1 = USB interrupt will cause an SMI event.
3	SMI on Port 64 Writes Enable (64WEN) — R/W. 0 = Disable 1 = A 1 in bit 11 will cause an SMI event.
2	SMI on Port 64 Reads Enable (64REN) — R/W. 0 = Disable 1 = A 1 in bit 10 will cause an SMI event.
1	SMI on Port 60 Writes Enable (60WEN) — R/W. 0 = Disable 1 = A 1 in bit 9 will cause an SMI event.
0	SMI on Port 60 Reads Enable (60REN) — R/W. 0 = Disable 1 = A 1 in bit 8 will cause an SMI event.

11.1.17 USB_RES—USB Resume Enable Register (USB—D29:F0/F1/F2)

Address Offset: C4h Attribute: R/W
 Default Value: 00h Size: 8 bits

Bit	Description
7:2	Reserved
1	PORT1EN — R/W. Enable port 1 of the USB controller to respond to wakeup events. 0 = The USB controller will not look at this port for a wakeup event. 1 = The USB controller will monitor this port for remote wakeup and connect/disconnect events.
0	PORT0EN — R/W. Enable port 0 of the USB controller to respond to wakeup events. 0 = The USB controller will not look at this port for a wakeup event. 1 = The USB controller will monitor this port for remote wakeup and connect/disconnect events.

11.2 USB I/O Registers

Some of the read/write register bits which deal with changing the state of the USB hub ports function such that on read back they reflect the current state of the port, and not necessarily the state of the last write to the register. This allows the software to poll the state of the port and wait until it is in the proper state before proceeding. A Host controller reset, Global reset, or Port reset will immediately terminate a transfer on the affected ports and disable the port. This affects the USBCMD register, bit [4] and the PORTSC registers, bits [12, 6, 2]. See individual bit descriptions for more detail.

Table 11-2. USB I/O Registers

Offset	Mnemonic	Register	Default	Type
00–01h	USBCMD	USB Command	0000h	R/W
02–03h	USBSTS	USB Status	0020h	R/WC
04–05h	USBINTR	USB Interrupt Enable	0000h	R/W
06–07h	FRNUM	USB Frame Number	0000h	R/W ⁽¹⁾
08–0Bh	FRBASEADD	USB Frame List Base Address	Undefined	R/W
0Ch	SOFMOD	USB Start of Frame Modify	40h	R/W
0D–0Fh		Reserved	0	RO
10–11h	PORTSC0	Port 0 Status/Control	0080h	R/WC, R/W, RO ⁽¹⁾
12–13h	PORTSC1	Port 1 Status/Control	0080h	R/WC, R/W, RO ⁽¹⁾
14–17h		Reserved	0	RO

NOTES:

1. These registers are Word writable only. Byte writes to these registers have unpredictable effects.

11.2.1 USBCMD—USB Command Register

I/O Offset: Base + (00–01h) Attribute: R/W
 Default Value: 0000h Size: 16 bits

The Command Register indicates the command to be executed by the serial bus host controller. Writing to the register causes a command to be executed. The table following the bit description provides additional information on the operation of the Run/Stop and Debug bits.

Bit	Description
15:7	Reserved
8	<p>Loop Back Test Mode — R/W.</p> <p>0 = Disable loop back test mode.</p> <p>1 = ICH4 is in loop back test mode. When both ports are connected together, a write to one port will be seen on the other port and the data will be stored in I/O offset 18h.</p>
7	<p>Max Packet (MAXP) — R/W. This bit selects the maximum packet size that can be used for full speed bandwidth reclamation at the end of a frame. This value is used by the Host controller to determine whether it should initiate another transaction based on the time remaining in the SOF counter. Use of reclamation packets larger than the programmed size will cause a Babble error if executed during the critical window at frame end. The Babble error results in the offending endpoint being stalled. Software is responsible for ensuring that any packet which could be executed under bandwidth reclamation be within this size limit.</p> <p>0 = 32 bytes</p> <p>1 = 64 bytes</p>
6	<p>Configure Flag (CF) — R/W. This bit has no effect on the hardware. It is provided only as a semaphore service for software.</p> <p>0 = Indicates that software has not completed host controller configuration.</p> <p>1 = HCD software sets this bit as the last action in its process of configuring the Host controller.</p>
5	<p>Software Debug (SWDBG) — R/W. The SWDBG bit must only be manipulated when the controller is in the stopped state. This can be determined by checking the HCHalted bit in the USBSTS register.</p> <p>0 = Normal Mode.</p> <p>1 = Debug mode. In SW Debug mode, the Host controller clears the Run/Stop bit after the completion of each USB transaction. The next transaction is executed when software sets the Run/Stop bit back to 1.</p>
4	<p>Force Global Resume (FGR) — R/W.</p> <p>0 = Software resets this bit to 0 after 20 ms has elapsed to stop sending the Global Resume signal. At that time all USB devices should be ready for bus activity. The 1-to-0 transition causes the port to send a low speed EOP signal. This bit will remain a 1 until the EOP has completed.</p> <p>1 = Host controller sends the Global Resume signal on the USB, and sets this bit to 1 when a resume event (connect, disconnect, or K-state) is detected while in global suspend mode.</p>
3	<p>Enter Global Suspend Mode (EGSM) — R/W.</p> <p>0 = Software resets this bit to 0 to come out of Global Suspend mode. Software writes this bit to 0 at the same time that Force Global Resume (bit 4) is written to 0 or after writing bit 4 to 0.</p> <p>1 = Host controller enters the Global Suspend mode. No USB transactions occur during this time. The Host controller is able to receive resume signals from USB and interrupt the system. Software must ensure that the Run/Stop bit (bit 0) is cleared prior to setting this bit.</p>

Bit	Description
2	<p>Global Reset (GRESET) — R/W.</p> <p>0 = This bit is reset by the software after a minimum of 10 ms has elapsed as specified in Chapter 7 of the USB Specification.</p> <p>1 = Global Reset. The Host controller sends the global reset signal on the USB and then resets all its logic, including the internal hub registers. The hub registers are reset to their power on state. Chip Hardware Reset has the same effect as Global Reset (bit 2), except that the Host controller does not send the Global Reset on USB.</p>
1	<p>Host Controller Reset (HCRESET) — R/W. The effects of HCRESET on Hub registers are slightly different from Chip Hardware Reset and Global USB Reset. The HCRESET affects bits [8,3:0] of the Port Status and Control Register (PORTSC) of each port. HCRESET resets the state machines of the Host controller including the Connect/Disconnect state machine (one for each port). When the Connect/Disconnect state machine is reset, the output that signals connect/disconnect are negated to 0, effectively signaling a disconnect, even if a device is attached to the port. This virtual disconnect causes the port to be disabled. This disconnect and disabling of the port causes bit 1 (connect status change) and bit 3 (port enable/disable change) of the PORTSC to get set. The disconnect also causes bit 8 of PORTSC to reset. About 64 bit times after HCRESET goes to 0, the connect and low-speed detect will take place, and bits 0 and 8 of the PORTSC will change accordingly.</p> <p>0 = Reset by the Host controller when the reset process is complete.</p> <p>1 = Reset. When this bit is set, the Host controller module resets its internal timers, counters, state machines, etc. to their initial value. Any transaction currently in progress on USB is immediately terminated.</p>
0	<p>Run/Stop (RS) — R/W. When set to 1, the ICH4 proceeds with execution of the schedule. The ICH4 continues execution as long as this bit is set. When this bit is cleared, the ICH4 completes the current transaction on the USB and then halts. The HC Halted bit in the status register indicates when the Host controller has finished the transaction and has entered the stopped state. The Host controller clears this bit when the following fatal errors occur: consistency check failure, PCI Bus errors.</p> <p>0 = Stop</p> <p>1 = Run</p> <p>NOTE: This bit should only be cleared if there are no active Transaction Descriptors in the executable schedule or software will reset the host controller prior to setting this bit again.</p>

Table 11-3. Run/Stop, Debug Bit Interaction SWDBG (Bit 5), Run/Stop (Bit 0) Operation

SWDBG (Bit 5)	Run/Stop (Bit 0)	Description
0	0	If executing a command, the Host controller completes the command and then stops. The 1.0 ms frame counter is reset and command list execution resumes from start of frame using the frame list pointer selected by the current value in the FRNUM register. (While Run/Stop=0, the FRNUM register can be reprogrammed).
0	1	Execution of the command list resumes from Start Of Frame using the frame list pointer selected by the current value in the FRNUM register. The Host controller remains running until the Run/Stop bit is cleared (by software or hardware).
1	0	If executing a command, the Host controller completes the command and then stops and the 1.0 ms frame counter is frozen at its current value. All status are preserved. The Host controller begins execution of the command list from where it left off when the Run/Stop bit is set.
1	1	Execution of the command list resumes from where the previous execution stopped. The Run/Stop bit is set to 0 by the Host controller when a TD is being fetched. This causes the Host controller to stop again after the execution of the TD (single step). When the Host controller has completed execution, the HC Halted bit in the Status Register is set.

When the USB Host controller is in software debug mode (USBCMD Register bit 5=1), the single-stepping software debug operation is as follows:

To enter software debug mode:

1. HCD puts Host controller in Stop state by setting the Run/Stop bit to 0.
2. HCD puts Host controller in debug mode by setting the SWDBG bit to 1.
3. HCD sets up the correct command list and Start Of Frame value for starting point in the Frame List Single Step Loop.
4. HCD sets Run/Stop bit to 1.
5. Host controller executes next active TD, sets Run/Stop bit to 0, and stops.
6. HCD reads the USBCMD register to check if the single step execution is completed (HCHalted=1).
7. HCD checks results of TD execution. Go to step 4 to execute next TD or step 8 to end software debug mode.
8. HCD ends Software Debug mode by setting SWDBG bit to 0.
9. HCD sets up normal command list and Frame List table.
10. HCD sets Run/Stop bit to 1 to resume normal schedule execution.

In software debug mode, when the Run/Stop bit is set, the Host controller starts. When a valid TD is found, the Run/Stop bit is reset. When the TD is finished, the HCHalted bit in the USBSTS register (bit 5) is set.

The software debug mode skips over inactive TDs and only halts after an active TD has been executed. When the last active TD in a frame has been executed, the Host controller waits until the next SOF is sent and then fetches the first TD of the next frame before halting.

This HCHalted bit can also be used outside of software debug mode to indicate when the Host controller has detected the Run/Stop bit and has completed the current transaction. Outside of the software debug mode, setting the Run/Stop bit to 0 always resets the SOF counter so that when the Run/Stop bit is set the Host controller starts over again from the frame list location pointed to by the Frame List Index (see FRNUM Register description) rather than continuing where it stopped.

11.2.2 USBSTS—USB Status Register

I/O Offset: Base + (02–03h) Attribute: R/WC
 Default Value: 0020h Size: 16 bits

This register indicates pending interrupts and various states of the Host controller. The status resulting from a transaction on the serial bus is not indicated in this register. Software sets a bit to 0 in this register by writing a 1 to it.

Bit	Description
15:6	Reserved
5	HCHalted — R/WC. 0 = Software resets this bit to 0 by writing a 1 to the bit position. 1 = The Host controller has stopped executing as a result of the Run/Stop bit being set to 0, either by software or by the Host controller hardware (debug mode or an internal error). Default.
4	Host Controller Process Error — R/WC. 0 = Software resets this bit to 0 by writing a 1 to the bit position. 1 = The Host controller has detected a fatal error. This indicates that the Host controller suffered a consistency check failure while processing a Transfer Descriptor. An example of a consistency check failure would be finding an illegal PID field while processing the packet header portion of the TD. When this error occurs, the Host controller clears the Run/Stop bit in the Command register to prevent further schedule execution. A hardware interrupt is generated to the system.
3	Host System Error — R/WC. 0 = Software resets this bit to 0 by writing a 1 to the bit position. 1 = A serious error occurred during a host system access involving the Host controller module. In a PCI system, conditions that set this bit to 1 include PCI Parity error, PCI Master Abort, and PCI Target Abort. When this error occurs, the Host controller clears the Run/Stop bit in the Command register to prevent further execution of the scheduled TDs. A hardware interrupt is generated to the system.
2	Resume Detect (RSM_DET) — R/WC. 0 = Software resets this bit to 0 by writing a 1 to the bit position. 1 = The Host controller received a “RESUME” signal from a USB device. This is only valid if the Host controller is in a global suspend state (bit 3 of Command register = 1).
1	USB Error Interrupt — R/WC. 0 = Software resets this bit to 0 by writing a 1 to the bit position. 1 = Completion of a USB transaction resulted in an error condition (e.g., error counter underflow). If the TD on which the error interrupt occurred also had its IOC bit set, both this bit and Bit 0 are set.
0	USB Interrupt (USBINT) — R/WC. 0 = Software resets this bit to 0 by writing a 1 to the bit position. 1 = The Host controller sets this bit when the cause of an interrupt is a completion of a USB transaction whose Transfer Descriptor had its IOC bit set. Also set when a short packet is detected (actual length field in TD is less than maximum length field in TD), and short packet detection is enabled in that TD.

11.2.3 USBINTR—Interrupt Enable Register

I/O Offset: Base + (04–05h) Attribute: R/W
 Default Value: 0000h Size: 16 bits

This register enables and disables reporting of the corresponding interrupt to the software. When a bit is set and the corresponding interrupt is active, an interrupt is generated to the host. Fatal errors (Host Controller Processor Error-bit 4, USBSTS Register) cannot be disabled by the host controller. Interrupt sources that are disabled in this register still appear in the Status Register to allow the software to poll for events.

Bit	Description
15:4	Reserved
3	Short Packet Interrupt Enable — R/W. 0 = Disabled. 1 = Enabled.
2	Interrupt On Complete (IOC) Enable — R/W. 0 = Disabled. 1 = Enabled.
1	Resume Interrupt Enable — R/W. 0 = Disabled. 1 = Enabled.
0	Timeout/CRC Interrupt Enable — R/W. 0 = Disabled. 1 = Enabled.

11.2.4 FRNUM—Frame Number Register

I/O Offset: Base + (06–07h) Attribute: R/W (Writes must be Word Writes)
 Default Value: 0000h Size: 16 bits

Bits [10:0] of this register contain the current frame number which is included in the frame SOF packet. This register reflects the count value of the internal frame number counter. Bits [9:0] are used to select a particular entry in the Frame List during scheduled execution. This register is updated at the end of each frame time.

This register must be written as a word. Byte writes are not supported. This register cannot be written unless the Host controller is in the STOPPED state as indicated by the HCHalted bit (USBSTS register). A write to this register while the Run/Stop bit is set (USBCMD register) is ignored.

Bit	Description
15:11	Reserved
10:0	Frame List Current Index/Frame Number — R/W. Provides the frame number in the SOF Frame. The value in this register increments at the end of each time frame (approximately every 1 ms). In addition, bits [9:0] are used for the Frame List current index and correspond to memory address signals [11:2].

11.2.5 FRBASEADD—Frame List Base Address

I/O Offset:	Base + (08–0Bh)	Attribute:	R/W
Default Value:	Undefined	Size:	32 bits

This 32-bit register contains the beginning address of the Frame List in the system memory. HCD loads this register prior to starting the schedule execution by the Host controller. When written, only the upper 20 bits are used. The lower 12 bits are written as 0s (4-KB alignment). The contents of this register are combined with the frame number counter to enable the Host controller to step through the Frame List in sequence. The two least significant bits are always 00. This requires DWord alignment for all list entries. This configuration supports 1024 Frame List entries.

Bit	Description
31:12	Base Address — R/W. These bits correspond to memory address signals [31:12], respectively.
11:0	Reserved

11.2.6 SOFMOD—Start of Frame Modify Register

I/O Offset: Base + (0Ch) Attribute: R/W
 Default Value: 40h Size: 8 bits

This 1-byte register is used to modify the value used in the generation of SOF timing on the USB. Only the 7 least significant bits are used. When a new value is written into these 7 bits, the SOF timing of the next frame will be adjusted. This feature can be used to adjust out any offset from the clock source that generates the clock that drives the SOF counter. This register can also be used to maintain real time synchronization with the rest of the system so that all devices have the same sense of real time. Using this register, the frame length can be adjusted across the full range required by the USB specification. Its initial programmed value is system dependent based on the accuracy of hardware USB clock and is initialized by system BIOS. It may be reprogrammed by USB system software at any time. Its value will take effect from the beginning of the next frame. This register is reset upon a Host Controller Reset or Global Reset. Software must maintain a copy of its value for reprogramming if necessary.

Bit	Description																								
7	Reserved																								
6:0	<p>SOF Timing Value — R/W. Guidelines for the modification of frame time are contained in Chapter 7 of the USB Specification. The SOF cycle time (number of SOF counter clock periods to generate a SOF frame length) is equal to 11936 + value in this field. The default value is decimal 64 which gives a SOF cycle time of 12000. For a 12 MHz SOF counter clock input, this produces a 1 ms Frame period. The following table indicates what SOF Timing Value to program into this field for a certain frame period.</p> <table border="1"> <thead> <tr> <th>Frame Length (# 12 MHz Clocks) (decimal)</th> <th>SOF Reg. Value (decimal)</th> </tr> </thead> <tbody> <tr><td>11936</td><td>0</td></tr> <tr><td>11937</td><td>1</td></tr> <tr><td>.</td><td>.</td></tr> <tr><td>.</td><td>.</td></tr> <tr><td>11999</td><td>63</td></tr> <tr><td>12000</td><td>64</td></tr> <tr><td>12001</td><td>65</td></tr> <tr><td>.</td><td>.</td></tr> <tr><td>.</td><td>.</td></tr> <tr><td>12062</td><td>126</td></tr> <tr><td>12063</td><td>127</td></tr> </tbody> </table>	Frame Length (# 12 MHz Clocks) (decimal)	SOF Reg. Value (decimal)	11936	0	11937	1	11999	63	12000	64	12001	65	12062	126	12063	127
Frame Length (# 12 MHz Clocks) (decimal)	SOF Reg. Value (decimal)																								
11936	0																								
11937	1																								
.	.																								
.	.																								
11999	63																								
12000	64																								
12001	65																								
.	.																								
.	.																								
12062	126																								
12063	127																								

11.2.7 PORTSC[0,1]—Port Status and Control Register

I/O Offset: Port 0/2/4: Base + (10–11h) Attribute: R/WC, RO, R/W (Word writes only)
 Port 1/3/5: Base + (12–13h)
 Default Value: 0080h Size: 16 bits

Note: For Function 0, this register applies to ICH4 USB ports 0 and 1; for Function 1, this register applies to ICH4 USB ports 2 and 3; for Function 2, this register applies to ICH4 USB ports 4 and 5.

After a Power-up reset, Global reset, or Host controller reset, the initial conditions of a port are: no device connected, port disabled, and the bus line status is 00 (single-ended zero).

Bit	Description								
15:13	Reserved — RO.								
12	<p>Suspend — R/W. This bit should not be written to a 1 if global suspend is active (bit 3=1 in the USBCMD register). Bit 2 and bit 12 of this register define the hub states as follows:</p> <table border="1"> <thead> <tr> <th>Bits [12,2]</th> <th>Hub State</th> </tr> </thead> <tbody> <tr> <td>X0</td> <td>Disable</td> </tr> <tr> <td>01</td> <td>Enable</td> </tr> <tr> <td>11</td> <td>Suspend</td> </tr> </tbody> </table> <p>When in suspend state, downstream propagation of data is blocked on this port, except for single-ended 0 resets (global reset and port reset). The blocking occurs at the end of the current transaction, if a transaction was in progress when this bit was written to 1. In the suspend state, the port is sensitive to resume detection. Note that the bit status does not change until the port is suspended and that there may be a delay in suspending a port if there is a transaction currently in progress on the USB.</p> <p>0 = Port not in suspend state. 1 = Port in suspend state.</p> <p>NOTE: Normally, if a transaction is in progress when this bit is set, the port will be suspended when the current transaction completes. However, in the case of a specific error condition (out transaction with babble), the ICH4 may issue a start-of-frame, and then suspend the port.</p>	Bits [12,2]	Hub State	X0	Disable	01	Enable	11	Suspend
Bits [12,2]	Hub State								
X0	Disable								
01	Enable								
11	Suspend								
11	<p>Over-current Indicator — R/WC. Set by hardware.</p> <p>0 = Software clears this bit by writing a 1 to the bit position. 1 = Overcurrent pin has gone from inactive to active on this port.</p>								
10	<p>Over-current Active — RO. This bit is set and cleared by hardware.</p> <p>0 = Indicates that the overcurrent pin is inactive (high). 1 = Indicates that the overcurrent pin is active (low).</p>								
9	<p>Port Reset — RO.</p> <p>0 = Port is not in Reset. 1 = Port is in Reset. When set, the port is disabled and sends the USB Reset signaling.</p>								
8	<p>Low Speed Device Attached (LS) — RO. Writes have no effect.</p> <p>0 = Full speed device is attached. 1 = Low speed device is attached to this port.</p>								
7	Reserved — RO. Always read as 1.								

Bit	Description
6	<p>Resume Detect (RSM_DET) — R/W. Software sets this bit to a 1 to drive resume signaling. The Host controller sets this bit to a 1 if a J-to-K transition is detected for at least 32 microseconds while the port is in the Suspend state. The ICH4 will then reflect the K-state back onto the bus as long as the bit remains a 1, and the port is still in the suspend state (bit 12,2 are 11). Writing a 0 (from 1) causes the port to send a low speed EOP. This bit will remain a 1 until the EOP has completed.</p> <p>0 = No resume (K-state) detected/driven on port. 1 = Resume detected/driven on port.</p>
5:4	<p>Line Status — RO. These bits reflect the D+ (bit 4) and D- (bit 5) signals line's logical levels. These bits are used for fault detect and recovery as well as for USB diagnostics. This field is updated at EOF2 time (See Chapter 11 of the USB Specification).</p>
3	<p>Port Enable/Disable Change — R/WC. For the root hub, this bit gets set only when a port is disabled due to disconnect on that port or due to the appropriate conditions existing at the EOF2 point (See Chapter 11 of the USB Specification).</p> <p>0 = No change. Software clears this bit by writing a 1 to the bit location. 1 = Port enabled/disabled status has changed.</p>
2	<p>Port Enabled/Disabled (PORT_EN) — R/W. Ports can be enabled by host software only. Ports can be disabled by either a fault condition (disconnect event or other fault condition) or by host software. Note that the bit status does not change until the port state actually changes and that there may be a delay in disabling or enabling a port if there is a transaction currently in progress on the USB.</p> <p>0 = Disable 1 = Enable..</p>
1	<p>Connect Status Change — R/WC. Indicates that a change has occurred in the port's Current Connect Status (see bit 0). The hub device sets this bit for any changes to the port device connect status, even if system software has not cleared a connect status change. If, for example, the insertion status changes twice before system software has cleared the changed condition, hub hardware will be setting an already-set bit (i.e., the bit will remain set). However, the hub transfers the change bit only once when the Host controller requests a data transfer to the Status Change endpoint. System software is responsible for determining state change history in such a case.</p> <p>0 = No change. Software clears this bit by writing a 1 to the bit location. 1 = Change in Current Connect Status.</p>
0	<p>Current Connect Status — RO. This value reflects the current state of the port, and may not correspond directly to the event that caused the Connect Status Change bit (Bit 1) to be set.</p> <p>0 = No device is present. 1 = Device is present on port.</p>

EHCI Controller Registers (D29:F7) 12

12.1 USB EHCI Configuration Registers (D29:F7)

Note: Register address locations not shown in Table 12-1 should be treated as Reserved (see Section 6.2 for details).

Table 12-1. USB EHCI PCI Configuration Register Address Map (D29:F7) (Sheet 1 of 2)

Offset	Mnemonic	Register Name	Default Value	Type
00–01h	VID	Vendor ID	8086h	RO
02–03h	DID	Device ID	24CDh	RO
04–05h	PCICMD	Command Register	0000h	R/W, RO
06–07h	PCISTS	Device Status	0290h	R/WC, RO
08h	REVID	Revision ID	See Note	RO
09h	PI	Programming Interface	20h	RO
0Ah	SCC	Sub Class Code	03h	RO
0Bh	BCC	Base Class Code	0Ch	RO
0Dh	MLT	Master Latency Timer	00h	RO
10–13h	MEM_BASE	Memory Base Address Register	00000000h	R/W, RO
2C–2Dh	SVID	Subsystem Vendor ID	XXXXh	R/W-Special
2E–2Fh	SID	Subsystem ID	XXXXh	R/W-Special
34h	CAP_PTR	Capabilities Pointer	50h	
3Ch	INT_LN	Interrupt Line	00h	R/W
3Dh	INT_PN	Interrupt Pin	04h	RO
50h	PWR_CAPID	Power Management Capability ID	01h	RO
51h	NXT_PRT1	Next Item Pointer #1	58h	R/W-Special
52–53h	PWR_CAP	Power Management Capabilities	C9C2h	R/W-Special
54–55h	PWR_CNTL_STS	Power Management Control/Status	0000h	R/W, R/WC
58h	DEBUG_CAPID	Debug Port Capability ID	0Ah	RO
59h	NXT_PRT2	Next Item Pointer #2	00h	RO
5A–5Bh	DEBUG_BASE	Debug Port Base Offset	2080h	RO
60h	USB_RELNUM	USB Release Number	20h	RO
61h	FL_ADJ	Frame Length Adjustment	20h	R/W
62–63h	PWAKE_CAP	Power Wake Capabilities	007Fh	R/W
66–67h		Reserved	0	RO
68–6Bh	LEG_EXT_CAP	USB EHCI Legacy Support Extended Capability	00000001h	R/W, RO

12.1.4 PCISTS—PCI Device Status Register (USB EHCI—D29:F7)

Address Offset: 06–07h Attribute: R/WC, RO
 Default Value: 0290h Size: 16 bits

Bit	Description
15	Detected Parity Error (DPE) — RO. Reserved as 0.
14	Signaled System Error (SSE) — R/WC. 0 = Software clears this bit by writing a 1 to this bit location. 1 = ICH4 signaled SERR# (internally). The SER_EN bit (bit 8 of the Command Register) must be 1 for this bit to be set.
13	Received Master Abort (RMA) — R/WC. 0 = Software clears this bit by writing a 1 to this bit location. 1 = USB EHCI, as a master, received a master abort status on a memory access. This is treated as a Host Error and halts the DMA engines. This event can optionally generate an SERR# by setting the SERR# Enable bit.
12	Received Target Abort (RTA) — R/WC. 0 = Software clears this bit by writing a 1 to this bit location. 1 = USB EHCI, as a master, received a target abort status on a memory access. This is treated as a Host Error and halts the DMA engines. This event can optionally generate an SERR# by setting the SERR# Enable bit.
11	Signaled Target Abort (STA) — RO. Hardwired to 0. This bit is used to indicate when the USB EHCI function responds to a cycle with a target abort. There is no reason for this to happen; thus, this bit is hardwired to 0.
10:9	DEVSEL# Timing Status (DEV_STS) — RO. This 2-bit field defines the timing for DEVSEL# assertion.
8	Master Data Parity Error Detected (DPED) — R/WC. 0 = Software clears this bit by writing a 1 to this bit location. 1 = ICH4 detected a data parity error on a USB EHCI read completion packet on the internal interface to the USB EHCI host controller (due to an equivalent data parity error on hub interface), and bit 6 of the Command register is set to 1.
7	Fast Back to Back Capable (FB2BC) — RO. Reserved as 1.
6	User Definable Features (UDF) — RO. Reserved as 0.
5	66 MHz Capable (66MHZ_CAP) — RO. Reserved as 0.
4	Capabilities List (CAP_LIST) — RO. This bit is hardwired to 1 indicating the presence of a valid capabilities pointer at offset 34h.
3:0	Reserved.

12.1.5 REVID—Revision ID Register (USB EHCI—D29:F7)

Offset Address: 08h Attribute: RO
 Default Value: See Bit Description Size: 8 bits

Bit	Description
7:0	Revision Identification Value — RO. Refer to the ICH4 Specification Update for the value of the Revision ID Register.

12.1.10 MEM_BASE—Memory Base Address Register (USB EHCI—D29:F7)

Address Offset: 10–13h Attribute: R/W, RO
 Default Value: 00000000h Size: 32 bits

Bit	Description
31:10	Base Address — R/W. Bits [31:10] correspond to memory address signals [31:10], respectively. This provides 1 KB of locatable memory space aligned to 1 KB boundaries.
9:4	Reserved
3	Prefetchable — RO. Hardwired to 0; indicates that this range should not be prefetched.
2:1	Type — RO. Hardwired to 00b; indicates that this range can be mapped anywhere within 32-bit address space.
0	Resource Type Indicator (RTE) — RO. Hardwired to 0; indicates that the base address field in this register maps to memory space.

12.1.11 SVID—USB EHCI Subsystem Vendor ID Register (USB EHCI—D29:F7)

Address Offset: 2C–2Dh Attribute: R/W-Special
 Default Value: XXXXh Size: 16 bits
 Reset: None

Bit	Description
15:0	Subsystem Vendor ID (SVID) — R/W-Special. This register, in combination with the USB EHCI Subsystem ID register, enables the operating system to distinguish each subsystem from the others. NOTE: Writes to this register are enabled when the WRT_RDONLY bit (offset 80h, bit 0) is set to 1.

12.1.12 SID—USB EHCI Subsystem ID Register (USB EHCI—D29:F7)

Address Offset: 2E–2Fh Attribute: R/W-Special
 Default Value: XXXXh Size: 16 bits
 Reset: None

Bit	Description
15:0	Subsystem ID (SID) — R/W-Special. BIOS sets the value in this register to identify the Subsystem ID. This register, in combination with the Subsystem Vendor ID register, enables the operating system to distinguish each subsystem from other(s). NOTE: Writes to this register are enabled when the WRT_RDONLY bit (offset 80h, bit 0) is set to 1.

12.1.17 NXT_PTR1—Next Item Pointer #1 Register (USB EHCI—D29:F7)

Address Offset: 51h Attribute: R/W-Special
Default Value: 58h Size: 8 bits

Bit	Description
7:0	Next Item Pointer #1 Value — R/W-Special. This register defaults to 58h, which indicates that the next capability registers begin at configuration offset 58h. This register is writable when the WRT_RDONLY bit is set. This allows BIOS to effectively hide the Debug Port capability registers, if necessary. This register should only be written during system initialization before the plug-and-play software has enabled any master-initiated traffic. Only values of 58h (Debug Port visible) and 00h (Debug Port invisible) are expected to be programmed in this register.

12.1.18 PWR_CAP—Power Management Capabilities Register (USB EHCI—D29:F7)

Address Offset: 52–53h Attribute: R/W-Special
Default Value: C9C2h Size: 16 bits

Bit	Description
15:11	PME Support — R/W-Special. This 5-bit field indicates the power states in which the function may assert PME#. The ICH4 EHC does not support the D1 or D2 states. For all other states, the ICH4 EHC is capable of generating PME#. Software should never need to modify this field.
10	D2 Support — R/W-Special. 0 = D2 State is not supported 1 = D2 State is supported
9	D1 Support — R/W-Special. 0 = D1 State is not supported 1 = D1 State is supported
8:6	Auxiliary Current — R/W-Special. The ICH4 EHC reports 375 mA maximum Suspend well current required when in the D3cold state. This value can be written by BIOS when a more accurate value is known.
5	DSI — R/W-Special. The ICH4 reports 0, indicating that no device-specific initialization is required.
4	Reserved
3	PME Clock — R/W-Special. The ICH4 reports 0, indicating that no PCI clock is required to generate PME#.
2:0	Version — R/W-Special. The ICH4 reports 010b, indicating that it complies with Revision 1.1 of the PCI Power Management Specification.

NOTES:

- Normally, this register is read-only to report capabilities to the power management software. To report different power management capabilities, depending on the system in which the ICH4/ICH4 is used, bits 15:11 and 8:6 in this register are writable when the WRT_RDONLY bit is set. The value written to this register does not affect the hardware other than changing the value returned during a read.
- Reset: core well, but not D3-to-D0 warm reset.

12.1.19 PWR_CNTL_STS—Power Management Control/Status Register (USB EHCI—D29:F7)

Address Offset: 54–55h Attribute: R/WC, R/W
 Default Value: 0000h Size: 16 bits

Bit	Description
15	<p>PME Status — R/WC.</p> <p>0 = Writing a 1 to this bit clears it and causes the internal PME to deassert (if enabled). Writing a 0 has no effect.</p> <p>1 = This bit is set when the ICH4 EHC would normally assert the PME# signal independent of the state of the PME_En bit.</p> <p>NOTE: This bit must be explicitly cleared by the operating system each time the operating system is loaded.</p>
14:13	Data Scale — RO. Hardwired to 00b; ICH4 does not support the associated Data register.
12:9	Data Select — RO. Hardwired to 0000b; ICH4 does not support the associated Data register.
8	<p>PME Enable — R/W.</p> <p>0 = Disable.</p> <p>1 = Enables the ICH4 EHC to generate an internal PME signal when PME_Status is 1.</p> <p>NOTE: This bit must be explicitly cleared by the operating system each time it is initially loaded.</p>
7:2	Reserved
1:0	<p>Power State — R/W. This 2-bit field is used both to determine the current power state of EHC function and to set a new power state. The definition of the field values are:</p> <p>00 = D0 state</p> <p>11 = D3 hot state</p> <p>If software attempts to write a value of 10b or 01b in to this field, the write operation must complete normally; however, the data is discarded and no state change occurs. When in the D3 hot state, the ICH4 must not accept accesses to the EHC memory range; but the configuration space must still be accessible. When not in the D0 state, the generation of the interrupt output is blocked. Specifically, the PIRQ[H] is not asserted by the ICH4 when not in the D0 state.</p> <p>When software changes this value from the D3 hot state to the D0 state, an internal warm (soft) reset is generated, and software must re-initialize the function.</p>

NOTE: Reset (bits 15, 8): suspend well, and not D3-to-D0 warm reset nor core well reset.

12.1.20 DEBUG_CAPID—Debug Port Capability ID Register (USB EHCI—D29:F7)

Address Offset: 58h Attribute: RO
 Default Value: 0Ah Size: 8 bits

Bit	Description
7:0	Debug Port Capability ID — RO. Hardwired to 0Ah; indicates that this is the start of a Debug Port Capability structure.

12.1.21 **NXT_PTR2—Next Item Pointer #2 Register (USB EHCI—D29:F7)**

Address Offset: 59h Attribute: RO
 Default Value: 00h Size: 8 bits

Bit	Description
7:0	Next Item Pointer 2 Capability — RO. Hardwired to 00h: indicates that there are no more capability structures in this function.

12.1.22 **DEBUG_BASE—Debug Port Base Offset Register (USB EHCI—D29:F7)**

Address Offset: 5Ah–5Bh Attribute: RO
 Default Value: 2080h Size: 16 bits

Bit	Description
15:13	BAR Number — RO. Hardwired to 001b: indicates the memory BAR begins at offset 10h in the EHCI configuration space.
12:0	Debug Port Offset — RO. Hardwired to 080h; indicates that the Debug Port registers begin at offset 80h in the EHCI memory range.

12.1.23 **USB_RELNUM—USB Release Number Register (USB EHCI—D29:F7)**

Address Offset: 60h Attribute: RO
 Default Value: 20h Size: 8 bits

Bit	Description
7:0	USB Release Number — RO. A value of 20h indicates that this controller follows the <i>Universal Serial Bus (USB) Specification, Revision 2.0</i> .

12.1.26 LEG_EXT_CAP—USB EHCI Legacy Support Extended Capability Register (USB EHCI—D29:F7)

Address Offset: 68–6Bh Attribute: R/W, RO
 Default Value: 0000001h Size: 32 bits
 Power Well: Suspend

Bit	Description
31:25	Reserved — RO. Hardwired to 00h
24	HC OS Owned Semaphore — R/W. System software sets this bit to request ownership of the EHCI controller. Ownership is obtained when this bit reads as 1 and the HC BIOS Owned Semaphore bit reads as clear.
23:17	Reserved — RO. Hardwired to 00h
16	HC BIOS Owned Semaphore — R/W. The BIOS sets this bit to establish ownership of the EHCI controller. System BIOS will clear this bit in response to a request for ownership of the EHCI controller by system software.
15:8	Next EHCI Capability Pointer — RO. A value of 00h indicates that there are no EHCI Extended Capability structures in this device.
7:0	Capability ID — RO. A value of 01h indicates that this EHCI Extended Capability is the Legacy Support Capability.

12.1.27 LEG_EXT_CS—USB EHCI Legacy Support Extended Control / Status Register (USB EHCI—D29:F7)

Address Offset: 6C–6Fh Attribute: R/W, R/WC, RO
 Default Value: 00000000h Size: 32 bits
 Power Well: Suspend

Bit	Description
31	SMI on BAR —R/WC. 0 = Software clears this bit by writing a 1 to this bit location. 1 = This bit is set to 1 whenever the Base Address Register (BAR) is written.
30	SMI on PCI Command — R/WC. 0 = Software clears this bit by writing a 1 to this bit location. 1 = This bit is set to 1 whenever the PCI Command Register is written.
29	SMI on OS Ownership Change — R/WC. 0 = Software clears this bit by writing a 1 to this bit location. 1 = HC OS Owned Semaphore bit in the USB EHCI Legacy Support Extended Capability register transitioned from 1-to-0 or 0-to-1.
28:22	Reserved — RO. Hardwired to 00h
21	SMI on Async Advance — RO. Shadow bit of the Interrupt on Async Advance bit in the EHCI_STS register. NOTE: To clear this bit system software must write a 1 to the Interrupt on Async Advance bit in the EHCI_STS register.
20	SMI on Host System Error — RO. Shadow bit of Host System Error bit in the EHCI_STS register. NOTE: To clear this bit system software must write a 1 to the Host System Error bit in the EHCI_STS register.

Bit	Description
19	SMI on Frame List Rollover — RO. Shadow bit of Frame List Rollover bit in the EHCI_STS register. NOTE: To clear this bit system software must write a 1 to the Frame List Rollover bit in the EHCI_STS register.
18	SMI on Port Change Detect — RO. Shadow bit of Port Change Detect bit in the EHCI_STS register. NOTE: To clear this bit system software must write a 1 to the Port Change Detect bit in the EHCI_STS register.
17	SMI on USB Error — RO. Shadow bit of USB Error Interrupt (USBERRINT) bit in the EHCI_STS register. NOTE: To clear this bit system software must write a 1 to the USB Error Interrupt bit in the EHCI_STS register.
16	SMI on USB Complete — RO. Shadow bit of USB Interrupt (USBINT) bit in the EHCI_STS register. NOTE: To clear this bit system software must write a 1 to the USB Interrupt bit in the EHCI_STS register.
15	SMI on BAR Enable — R/W. 0 = Disable. 1 = Enable. When this bit is 1 and SMI on BAR is 1, then the host controller will issue an SMI.
14	SMI on PCI Command Enable — R/W. 0 = Disable. 1 = Enable. When this bit is 1 and SMI on PCI Command is 1, then the host controller will issue an SMI.
13	SMI on OS Ownership Enable — R/W. 0 = Disable. 1 = Enable. When this bit is a 1 AND the OS Ownership Change bit is 1, the host controller will issue an SMI.
12:6	Reserved — RO. Hardwired to 00h
5	SMI on Async Advance Enable — R/W. 0 = Disable. 1 = Enable. When this bit is a 1, and the SMI on Async Advance bit is a 1, the host controller will issue an SMI immediately.
4	SMI on Host System Error Enable — R/W. 0 = Disable. 1 = Enable. When this bit is a 1, and the SMI on Host System Error is a 1, the host controller will issue an SMI.
3	SMI on Frame List Rollover Enable — R/W. 0 = Disable. 1 = Enable. When this bit is a 1, and the SMI on Frame List Rollover bit is a 1, the host controller will issue an SMI.
2	SMI on Port Change Enable — R/W. 0 = Disable. 1 = Enable. When this bit is a 1, and the SMI on Port Change Detect bit is a 1, the host controller will issue an SMI.
1	SMI on USB Error Enable — R/W. 0 = Disable. 1 = Enable. When this bit is a 1, and the SMI on USB Error bit is a 1, the host controller will issue an SMI immediately.
0	SMI on USB Complete Enable — R/W. 0 = Disable. 1 = Enable. When this bit is a 1, and the SMI on USB Complete bit is a 1, the host controller will issue an SMI immediately.

12.1.28 SPECIAL_SMI—Intel Specific USB EHCI SMI Register (USB EHCI—D29:F7)

Address Offset:	70–73h	Attribute:	R/WC, R/W
Default Value:	00000000h	Size:	32 bits
Power Well:	Suspend		

This register provides a mechanism for BIOS to provide USB EHCI related bug fixes and workarounds. Writing a 1 to that bit location clears bits that are marked as Read/Write-Clear (R/WC). Software should clear all SMI status bits prior to setting the global SMI enable bit and individual SMI enable bit to prevent spurious SMI when returning from a powerdown.

Bit	Description
31:28	Reserved — RO. Hardwired to 00h
27:22	SMI on PortOwner — R/WC. 0 = Software clears these bits by writing a 1 to the bit location. 1 = Bits 27:22 correspond to the Port Owner bits for ports 1 (22) through 6 (27). These bits are set to 1 whenever the associated Port Owner bits transition from 0-to-1 or 1-to-0.
21	SMI on PMCSR — R/WC. 0 = Software clears this bit by writing a 1 to the bit location. 1 = Software modified the Power State bits in the Power Management Control/Status (PMCSR) register.
20	SMI on Async — R/WC. 0 = Software clears this bit by writing a 1 to the bit location. 1 = Async Schedule Enable bit transitioned from 1->0 or 0->1.
19	SMI on Periodic — R/WC. 0 = Software clears this bit by writing a 1 to the bit location. 1 = Periodic Schedule Enable bit transitioned from 1-to-0 or 0-to-1
18	SMI on CF — R/WC. 0 = Software clears this bit by writing a 1 to the bit location. 1 = Configure Flag (CF) transitioned from 1-to-0 or 0-to-1.
17	SMI on HCHalted — R/WC. 0 = Software clears this bit by writing a 1 to the bit location. 1 = HCHalted transitions to 1 (as a result of the Run/Stop bit being cleared).
16	SMI on HCRreset — R/WC. 0 = Software clears this bit by writing a 1 to the bit location. 1 = HCRESET transitioned to 1.
15:12	Reserved — RO. Hardwired to 00h
11:6	SMI on PortOwner Enable — R/W. 0 = Disable 1 = Enable. When any of these bits are 1 and the corresponding SMI on PortOwner bits are 1, the host controller will issue an SMI. Unused ports should have their corresponding bits cleared.
5	SMI on PMSCR Enable — R/W. 0 = Disable 1 = Enable. When this bit is 1 and SMI on PMSCR is 1, then the host controller will issue an SMI.
4	SMI on Async Enable — R/W. 0 = Disable 1 = Enable. When this bit is 1 and SMI on Async is 1, then the host controller will issue an SMI.

Bit	Description
3	SMI on Periodic Enable — R/W. 0 = Disable 1 = Enable. When this bit is 1 and SMI on Periodic is 1, then the host controller will issue an SMI.
2	SMI on CF Enable — R/W. 0 = Disable 1 = Enable. When this bit is 1 and SMI on CF is 1, then the host controller will issue an SMI.
1	SMI on HCHalted Enable — R/W. 0 = Disable 1 = Enable. When this bit is 1 and SMI on HCHalted is 1, then the host controller will issue an SMI.
0	SMI on HCReset Enable — R/W. 0 = Disable 1 = Enable. When this bit is 1 and SMI on HCReset is 1, then host controller will issue an SMI— R/W.

12.1.29 ACCESS_CNTL—Access Control Register (USB EHCI—D29:F7)

Address Offset: 80h Attribute: R/W
Default Value: 00h Size: 8 bits

Bit	Description
7:1	Reserved
0	WRT_RDONLY — R/W. 0 = Disable 1 = Enables a select group of normally read-only registers in the EHC function to be written by software. Registers that may only be written when this mode is entered are noted in the summary tables and detailed description as “Read/Write-Special”. The registers fall into two categories: - System-configured parameters, and - Status bits

12.1.30 HS_Ref_V—USB HS Reference Voltage Register (USB EHCI—D29:F7)

Offset Address: DC–DFh Attribute: R/W
Default Value: 00000000h Size: 32 bit
Lockable: No Power Well: Resume

Bit	Description
31:22	Reserved— RO.
21:16	USB HS Ref Voltage — RW. BIOS should always program this register to the recommended value of 111111. All other values are reserved
15:0	Reserved— RO.

12.2.1.2 HCIVERSION—Host Controller Interface Version Number Register

Offset: 02–03h Attribute: RO
 Default Value: 0100h Size: 16 bits

Bit	Description
15:0	This is a two-byte register containing a BCD encoding of the version number of interface that this host controller interface conforms.

12.2.1.3 HCSPARAMS—Host Controller Structural Parameters Register

Offset: 04–07h Attribute: R/W-Special
 Default Value: 00103206h Size: 32 bits

Note: This register is reset by a suspend well reset and not a D3-to-D0 reset or HCRESET.

Bit	Description
31:24	Reserved — RO. Default=0h.
23:20	Debug Port Number (DP_N) — R/W-Special. Hardwired to 1h; indicates that the Debug Port is on the lowest numbered port on the ICH4.
19:17	Reserved
16	Reserved. Should be written to 0.
15:12	Number of Companion Controllers (N_CC) — R/W-Special. This field indicates the number of companion controllers associated with this USB ECHI host controller. A 0h in this field indicates there are no companion host controllers. Port-ownership hand-off is not supported. Only high-speed devices are supported on the host controller root ports. A value larger than 1 in this field indicates there are companion USB UHCI host controller(s). Port-ownership hand-offs are supported. High, Full- and Low-speed devices are supported on the host controller root ports. The ICH4 allows the default value of 3h to be over-written by BIOS. Since the ICH4 cannot support more than 3 companion host controllers, bits 15:14 are implemented as read-only 00b. When removing classic controllers, they should be disabled in the following order: Function 2, Function 1, and Function 0, which correspond to ports 5:4, 3:2, and 1:0, respectively.
11:8	Number of Ports per Companion Controller (N_PCC) — RO. Hardwired to 0010. This field indicates the number of ports supported per companion host controller. It is used to indicate the port routing configuration to system software.
7:4	Reserved. These bits are reserved and default to 0h.
3:0	N_PORTS — R/W-Special. This field specifies the number of physical downstream ports implemented on this host controller. The value of this field determines how many port registers are addressable in the Operational Register Space. Valid values are in the range of 1h to Fh. The default is 0110 (6h). However, software may write a value less than 6 for some platform configurations. A 0h in this field is undefined. Bit 3 is always hardwired to 0.

NOTE: This register is writable when the WRT_RDONLY bit is set.

12.2.1.4 HCCPARAMS—Host Controller Capability Parameters Register

Offset: 08–0Bh Attribute: RO
 Default Value: 00006871h Size: 32 bits

Bit	Description
31:16	Reserved
15:8	EHCI Extended Capabilities Pointer (EECP) — RO. Hardwired to 68h, indicating that the EHCI capabilities list exists and begins at offset 68h in the PCI configuration space.
7:4	<p>Isosynchronous Scheduling Threshold — RO. Hardwired to 7h (0111). This field indicates, relative to the current position of the executing host controller, where software can reliably update the isochronous schedule.</p> <p>When bit 7 is 0, the value of the least significant 3 bits indicates the number of micro-frames a host controller hold a set of isochronous data structures (one or more) before flushing the state.</p> <p>When bit 7 is a 1, host software assumes the host controller may cache an isochronous data structure for an entire frame. Refer to the EHCI specification for details on how software uses this information for scheduling isochronous transfers.</p>
3	Reserved. Should be set to 0.
2	Asynchronous Schedule Park Capability — RO. Hardwired to 0, indicating that the Host controller does not support this optional feature
1	<p>Programmable Frame List Flag — RO.</p> <p>0 = System software must use a frame list length of 1024 elements with this host controller. The USBCMD register <i>Frame List Size</i> field is a read-only register and must be set to zero.</p> <p>1 = System software can specify and use a smaller frame list and configure the host controller via the USBCMD register <i>Frame List Size</i> field. The frame list must always be aligned on a 4K page boundary. This requirement ensures that the frame list is always physically contiguous.</p>
0	<p>64-bit Addressing Capability— RO. Hardwired to 1. This field documents the addressing range capability of this implementation. The value of this field determines whether software should use the 32-bit or 64-bit data structures. Values for this field have the following interpretation:</p> <p>0 = Data structures using 32-bit address memory pointers</p> <p>1 = Data structures using 64-bit address memory pointers</p> <p>NOTE: The ICH4 only implements 44 bits of addressing. Bits 63:44 will always be 0.</p>

12.2.2 Host Controller Operational Registers

This section defines the enhanced host controller operational registers. These registers are located after the capabilities registers. The operational register base must be DWord-aligned and is calculated by adding the value in the first capabilities register (CAPLENGTH) to the base address of the enhanced host controller register address space. All registers are 32 bits in length.

Table 12-3. Enhanced Host Controller Operational Registers

Offset (CAPLENG+)	Mnemonic	Register Name	Default	Special Notes	Type
00–03h	EHCI_CMD	USB EHCI Command	00080000h		R/W, RO
04–07h	EHCI_STS	USB EHCI Status	00001000h		R/WC, RO
08–0Bh	EHCI_INTR	USB EHCI Interrupt Enable	00000000h		R/W
0C–0Fh	FRINDEX	USB EHCI Frame Index	00000000h		R/W
10–13h	CTRLDSSEGMENT	Control Data Structure Segment	00000000h		R/W
14–17h	PERIODICLISTBASE	Period Frame List Base Address	00000000h		R/W
18–1Bh	ASYNCLISTADDR	Next Asynchronous List Address	00000000h		R/W
1C–3Fh		Reserved	0h		RO
40–43h	CONFIGFLAG	Configure Flag Register	00000000h	Suspend	R/W
44–47h	PORTSC0	Port 0 Status and Control	00003000h	Suspend	R/WC, R/W, RO
48–4Bh	PORTSC1	Port 1 Status and Control	00003000h	Suspend	R/WC, R/W, RO
4C–4Fh	PORTSC2	Port 2 Status and Control	00003000h	Suspend	R/WC, R/W, RO
50–53h	PORTSC3	Port 3 Status and Control	00003000h	Suspend	R/WC, R/W, RO
54–57h	PORTSC4	Port 4 Status and Control	00003000h	Suspend	R/WC, R/W, RO
58–5Bh	PORTSC5	Port 5 Status and Control	00003000h	Suspend	R/WC, R/W, RO
5C–5Fh		Reserved	Undefined		RO
60–73h		Debug Port Registers	Undefined		RO
74–3FFh		Reserved	Undefined		RO

Note: Software must read and write these registers using only DWord accesses. These registers are divided into two sets. The first set at offset 00:3Fh are implemented in the core power well. Unless otherwise noted, the core-well registers are reset by the assertion of any of the following:

- core well hardware reset
- HCRESET
- D3-to-D0 reset

The second set at offset 40h to the end of the implemented register space are implemented in the Suspend power well. Unless otherwise noted, the suspend-well registers are reset by the assertion of either of the following:

- suspend well hardware reset
- HCRESET

12.2.2.1 EHCI_CMD—USB EHCI Command Register

Offset: CAPLENGTH + 00–03h Attribute: R/W, RO
 Default Value: 00080000h Size: 32 bits

Bit	Description
31:24	Reserved. Should be set to 0s.
23:16	<p>Interrupt Threshold Control — R/W. This field is used by system software to select the maximum rate at which the host controller will issue interrupts. The only valid values are defined below. If software writes an invalid value to this register, the results are undefined.</p> <p>00h = Reserved 01h = 1 micro-frame 02h = 2 micro-frames 04h = 4 micro-frames 08h = 8 micro-frames (default, equates to 1 ms) 10h = 16 micro-frames (2 ms) 20h = 32 micro-frames (4 ms) 40h = 64 micro-frames (8 ms)</p>
15:8	Reserved. Should be set to 0s.
11:8	Unimplemented Asynchronous Park Mode Bits — RO. Hardwired to 000b; the host controller does not support this optional feature.
7	Light Host Controller Reset — RO. Hardwired to 0; the ICH4 does not implement this optional reset.
6	<p>Interrupt on Async Advance Doorbell — R/W. This bit is used as a doorbell by software to tell the host controller to issue an interrupt the next time it advances asynchronous schedule.</p> <p>0 = The host controller sets this bit to a 0 after it has set the Interrupt on Async Advance status bit in the EHCI_STS register to a 1.</p> <p>1 = Software must write a 1 to this bit to ring the doorbell. When the host controller has evicted all appropriate cached schedule state, it sets the Interrupt on Async Advance status bit in the EHCI_STS register. If the Interrupt on Async Advance Enable bit in the USBINTR register is a 1 then the host controller will assert an interrupt at the next interrupt threshold. See the <i>Enhanced Host Controller Interface (EHCI) Specification for Universal Serial Bus</i> for operational details.</p> <p>Software should not write a 1 to this bit when the asynchronous schedule is inactive. Doing this will yield undefined results.</p>
5	<p>Asynchronous Schedule Enable — R/W. This bit controls whether the host controller skips processing the Asynchronous Schedule.</p> <p>0 = Do not process the Asynchronous Schedule (Default) 1 = Use the ASYNCLISTADDR register to access the Asynchronous Schedule.</p>
4	<p>Periodic Schedule Enable — R/W. This bit controls whether the host controller skips processing the Periodic Schedule.</p> <p>0 = Do not process the Periodic Schedule (Default) 1 = Use the PERIODICLISTBASE register to access the Periodic Schedule.</p>
3:2	Frame List Size — RO. Hardwired to 00; ICH4 only supports the 1024-element frame list size.

Bit	Description															
1	<p>Host Controller Reset (HCRESET) — R/W. This control bit used by software to reset the host controller. The effects of this on Root Hub registers are similar to a Chip Hardware Reset (i.e., RSMRST# assertion and PWROK deassertion on the ICH4).</p> <p>0 = This bit is set to 0 by the Host controller when the reset process is complete. Software cannot terminate the reset process early by writing a 0 to this bit.</p> <p>1 = When software writes a 1 to this bit, the Host controller resets its internal pipelines, timers, counters, state machines, etc. to their initial value. Any transaction currently in progress on USB is immediately terminated. A USB reset is not driven on downstream ports.</p> <p>All operational registers, including port registers and port state machines are set to their initial values. Port ownership reverts to the companion host controller(s), with the side effects described in the EHCI spec. Software must re-initialize the host controller in order to return the host controller to an operational state.</p> <p>Software should not set this bit to a 1 when the HCHalted bit in the EHCI_STS register is a 0. Attempting to reset an actively running host controller will result in undefined behavior. This reset me be used to leave EHCI port test modes.</p> <p>NOTE: PCI Configuration registers and Host Controller Capability Registers are not effected by this reset.</p>															
0	<p>Run/Stop (RS) — R/W.</p> <p>0 = Stop (Default)</p> <p>1 = Run. When set to a 1, the Host controller proceeds with execution of the schedule. The Host controller continues execution as long as this bit is set. When this bit is set to 0, the Host controller completes the current transaction on the USB and then halts. The HC Halted bit in the status register indicates when the Host controller has finished the transaction and has entered the stopped state.</p> <p>NOTE: Software should not write a 1 to this field unless the host controller is in the Halted state (i.e., HCHalted in the EHCI_STS register is a 1). The Halted bit is cleared immediately when the Run bit is set.</p> <p>The following table explains how the different combinations of Run and Halted should be interpreted:</p> <table border="1" style="width: 100%; border-collapse: collapse;"> <thead> <tr> <th style="text-align: left;">Run/Stop</th> <th style="text-align: left;">Halted</th> <th style="text-align: left;">Interpretation</th> </tr> </thead> <tbody> <tr> <td>0</td> <td>0</td> <td>Valid- in the process of halting</td> </tr> <tr> <td>0</td> <td>1</td> <td>Valid- halted</td> </tr> <tr> <td>1</td> <td>0</td> <td>Valid- running</td> </tr> <tr> <td>1</td> <td>1</td> <td>Invalid- the HCHalted bit clears immediately.</td> </tr> </tbody> </table> <p>Memory read cycles initiated by the EHC that receive any status other than Successful will result in this bit being cleared.</p>	Run/Stop	Halted	Interpretation	0	0	Valid- in the process of halting	0	1	Valid- halted	1	0	Valid- running	1	1	Invalid- the HCHalted bit clears immediately.
Run/Stop	Halted	Interpretation														
0	0	Valid- in the process of halting														
0	1	Valid- halted														
1	0	Valid- running														
1	1	Invalid- the HCHalted bit clears immediately.														

NOTE: The Command Register indicates the command to be executed by the serial bus host controller. Writing to the register causes a command to be executed.

12.2.2.2 EHCI_STS—USB EHCI Status Register

Offset: CAPLENGTH + 04–07h Attribute: R/WC, RO
 Default Value: 00001000h Size: 32 bits

This register indicates pending interrupts and various states of the Host controller. The status resulting from a transaction on the serial bus is not indicated in this register. Software sets a bit to 0 in this register by writing a 1 to it. See the Interrupts description in Chapter 4 of the *Enhanced Host Controller Interface (EHCI) Specification for Universal Serial Bus* for additional information concerning USB EHCI interrupt conditions.

Bit	Description
31:16	Reserved. Should be set to 0s.
15	Asynchronous Schedule Status — RO. This bit reports the current real status of the Asynchronous Schedule. The Host controller is not required to <i>immediately</i> disable or enable the Asynchronous Schedule when software transitions the <i>Asynchronous Schedule Enable</i> bit in the USBCMD register. When this bit and the <i>Asynchronous Schedule Enable</i> bit are the same value, the Asynchronous Schedule is either enabled (1) or disabled (0). 0 = Disable. (Default) 1 = Enable. The status of the Asynchronous Schedule is enabled.
14	Periodic Schedule Status — RO. This bit reports the current real status of the Periodic Schedule. The Host controller is not required to <i>immediately</i> disable or enable the Periodic Schedule when software transitions the <i>Periodic Schedule Enable</i> bit in the USBCMD register. When this bit and the <i>Periodic Schedule Enable</i> bit are the same value, the Periodic Schedule is either enabled (1) or disabled (0). 0 = Disable. (Default). 1 = Enable. The status of the Periodic Schedule is enabled.
13	Reclamation — RO. (Defaults to 1). This bit is used to detect an empty asynchronous schedule. The operational model and valid transitions for this bit are described in Section 4 of the EHCI Specification.
12	HCHalted — RO. 0 = This bit is a 0 when the Run/Stop bit is a 1. 1 = The Host controller sets this bit to 1 after it has stopped executing as a result of the Run/Stop bit being set to 0, either by software or by the Host controller hardware (e.g., internal error). (Default)
11:6	Reserved
5	Interrupt on Async Advance — R/WC. 0=Default. 0 = Interrupt not occurred (source not asserted). 1 = Interrupt occurred (source asserted). System software can force the host controller to issue an interrupt the next time the host controller advances the asynchronous schedule by writing a 1 to the <i>Interrupt on Async Advance Doorbell</i> bit in the USBCMD register. This bit indicates the assertion of that interrupt source.
4	Host System Error — RO. 0 = No host system error during access of the Host controller module. 1 = Host system error. The Host controller sets this bit to 1 when a serious error occurs during a host system access involving the Host controller module. A hardware interrupt is generated to the system. Memory read cycles initiated by the EHC that receive any status other than Successful will result in this bit being set. When this error occurs, the Host controller clears the Run/Stop bit in the Command register to prevent further execution of the scheduled TDs. A hardware interrupt is generated to the system (if enabled in the Interrupt Enable Register).

Bit	Description
3	<p>Frame List Rollover — R/WC.</p> <p>0 = No rollover.</p> <p>1 = Frame List Rollover. The Host controller sets this bit to a 1 when the <i>Frame List Index</i> (see Section) rolls over from its maximum value to zero. Since the ICH4 only supports the 1024-entry Frame List Size, the <i>Frame List Index</i> rolls over every time FRNUM[13] toggles.</p>
2	<p>Port Change Detect — R/WC.</p> <p>0 = Not Detected.</p> <p>1 = Port Change Detected. The Host controller sets this bit to a 1 when any port for which the <i>Port Owner</i> bit is set to 0 has a change bit transition from 0 to 1 or a Force Port Resume bit transition from 0 to 1 as a result of a J-K transition detected on a suspended port.</p>
1	<p>USB Error Interrupt (USBERRINT) — R/WC.</p> <p>0 = No Error.</p> <p>1 = Error Condition. The Host controller sets this bit to 1 when completion of a USB transaction results in an error condition (e.g., error counter underflow). If the TD on which the error interrupt occurred also had its IOC bit set, both this bit and Bit 0 are set. See the EHCI specification for a list of the USB errors that will result in this interrupt being asserted.</p>
0	<p>USB Interrupt (USBINT) — R/WC.</p> <p>0 = Software clears this bit by writing a 1 to the bit location.</p> <p>1 = The Host controller sets this bit to 1 when one of the following occurs:</p> <ul style="list-style-type: none"> • The cause of an interrupt is a completion of a USB transaction whose Transfer Descriptor had its IOC bit set. • The Host controller also sets this bit to 1 when a short packet is detected (actual number of bytes received was less than the expected number of bytes).

12.2.2.3 EHCI_INTR—USB EHCI Interrupt Enable Register

Offset: CAPLENGTH + 08–0Bh Attribute: R/W
 Default Value: 00000000h Size: 32 bits

This register enables and disables reporting of the corresponding interrupt to the software. When a bit is set and the corresponding interrupt is active, an interrupt is generated to the host. Interrupt sources that are disabled in this register still appear in the Status Register to allow the software to poll for events. Each interrupt enable bit description indicates whether it is dependent on the interrupt threshold mechanism, or not (see Chapter 4 of the *Enhanced Host Controller Interface (EHCI) Specification for Universal Serial Bus*).

Bit	Description
31:6	Reserved. Should be 0s.
5	Interrupt on Async Advance Enable — R/W. When this bit is a 1, and the Interrupt on Async Advance bit in the EHCI_STS register is a 1, the host controller will issue an interrupt at the next interrupt threshold. The interrupt is acknowledged by software clearing the Interrupt on Async Advance bit in the EHCI_STS register. 0 = Disable 1 = Enable
4	Host System Error Enable — R/W. When this bit is a 1, and the Host System Error Status bit in the EHCI_STS register is a 1, the host controller will issue an interrupt. The interrupt is acknowledged by software clearing the Host System Error bit in the EHCI_STS register. 0 = Disable 1 = Enable
3	Frame List Rollover Enable — R/W. When this bit is a 1, and the Frame List Rollover bit in the EHCI_STS register is a 1, the host controller will issue an interrupt. The interrupt is acknowledged by software clearing the Frame List Rollover bit in the EHCI_STS register. 0 = Disable 1 = Enable
2	Port Change Interrupt Enable — R/W. When this bit is a 1, and the Port Change Detect bit in the EHCI_STS register is a 1, the host controller will issue an interrupt. The interrupt is acknowledged by software clearing the Port Change Detect bit in the EHCI_STS register. 0 = Disable 1 = Enable
1	USB Error Interrupt Enable — R/W. When this bit is a 1, and the USBERRINT bit in the EHCI_STS register is a 1, the host controller will issue an interrupt at the next interrupt threshold. The interrupt is acknowledged by software by clearing the USBERRINT bit in the EHCI_STS register. 0 = Disable 1 = Enable
0	USB Interrupt Enable — R/W. When this bit is a 1, and the USBINT bit in the EHCI_STS register is a 1, the host controller will issue an interrupt at the next interrupt threshold. The interrupt is acknowledged by software by clearing the USBINT bit in the EHCI_STS register. 0 = Disable 1 = Enable

12.2.2.4 FRINDEX—Frame Index Register

Offset: CAPLENGTH + 0C–0Fh Attribute: R/W
 Default Value: 00000000h Size: 32 bits

The SOF frame number value for the bus SOF token is derived or alternatively managed from this register. Refer to Section 4 of the EHCI specification for a detailed explanation of the SOF value management requirements on the host controller. The value of FRINDEX must be within 125 μ s (1 micro-frame) ahead of the SOF token value. The SOF value may be implemented as an 11-bit shadow register. For this discussion, this shadow register is 11 bits and is named SOFV. SOFV updates every 8 micro-frames. (1 millisecond). An example implementation to achieve this behavior is to increment SOFV each time the FRINDEX[2:0] increments from 0 to 1.

Software must use the value of FRINDEX to derive the current micro-frame number, both for high-speed isochronous scheduling purposes and to provide the **get** micro-frame number function required to client drivers. Therefore, the value of FRINDEX and the value of SOFV must be kept consistent if chip is reset or software writes to FRINDEX. Writes to FRINDEX must also **write-through** FRINDEX[13:3] to SOFV[10:0]. In order to keep the update as simple as possible, software should never write a FRINDEX value where the three least significant bits are 111b or 000b.

Note: This register is used by the host controller to index into the periodic frame list. The register updates every 125 microseconds (once each micro-frame). Bits [12:3] are used to select a particular entry in the Periodic Frame List during periodic schedule execution. The number of bits used for the index is fixed at 10 for the ICH4 since it only supports 1024-entry frame lists. This register must be written as a DWord. Word and byte writes produce undefined results. This register cannot be written unless the Host controller is in the Halted state as indicated by the *HCHalted* bit (USB EHCI STS register). A write to this register while the Run/Stop bit is set to a 1 (USB EHCI CMD register) produces undefined results. Writes to this register also effect the SOF value. For details, see Chapter 4 of the *Enhanced Host Controller Interface (EHCI) Specification for Universal Serial Bus*.

Bit	Description
31:14	Reserved
13:0	Frame List Current Index/Frame Number — R/W. The value in this register increments at the end of each time frame (e.g., micro-frame). Bits [12:3] are used for the Frame List current index. This means that each location of the frame list is accessed 8 times (frames or micro-frames) before moving to the next index.

12.2.2.5 CTRLDSSEGMENT—Control Data Structure Segment Register

Offset: CAPLENGTH + 10–13h Attribute: R/W
 Default Value: 00000000h Size: 32 bits

This 32-bit register corresponds to the most significant address bits [63:32] for all EHCI data structures. Since the ICH4 hardwires the 64-bit Addressing Capability field in HCCPARAMS to 1s, then this register is used with the link pointers to construct 64-bit addresses to EHCI control data structures. This register is concatenated with the link pointer from either the PERIODICLISTBASE, ASYNCLISTADDR, or any control data structure link field to construct a 64-bit address. This register allows the host software to locate all control data structures within the same 4 GB memory segment.

Bit	Description
31:12	Upper Address [63:44] — R/W. These bits are hardwired, read-only to 0 in the ICH4. The ICH4 EHC is only capable of generating addresses up to 16 terabytes (44 bits of address).
11:0	Upper Address [43:32] — R/W. This 12-bit field corresponds to address bits 43:32 when forming a control data structure address.

12.2.2.6 PERIODICLISTBASE—Periodic Frame List Base Address Register

Offset: CAPLENGTH + 14–17h Attribute: R/W
 Default Value: 00000000h Size: 32 bits

This 32-bit register contains the beginning address of the Periodic Frame List in the system memory. Since the ICH4 host controller operates in 64-bit mode (as indicated by the one in the 64-bit Addressing Capability field in the HCCSPARAMS register), then the most significant 32 bits of every control data structure address comes from the CTRLDSSEGMENT register. HCD loads this register prior to starting the schedule execution by the Host controller. The memory structure referenced by this physical memory pointer is assumed to be 4-KB aligned. The contents of this register are combined with the Frame Index Register (FRINDEX) to enable the Host controller to step through the Periodic Frame List in sequence.

Bit	Description
31:12	Base Address (Low) — R/W. These bits correspond to memory address signals [31:12], respectively.
11:0	Reserved. Must be written as 0s. During runtime, the value of these bits are undefined.

12.2.2.7 ASYNCLISTADDR—Current Asynchronous List Address Register

Offset: CAPLENGTH + 18–1Bh Attribute: R/W
 Default Value: 00000000h Size: 32 bits

This 32-bit register contains the address of the next asynchronous queue head to be executed. Since the ICH4 host controller operates in 64-bit mode (as indicated by a one in 64-bit Addressing Capability field in the HCCPARAMS register), then the most significant 32 bits of every control data structure address comes from the CTRLDSSEGMENT register. Bits [4:0] of this register cannot be modified by system software and will always return zeros when read. The memory structure referenced by this physical memory pointer is assumed to be 32-byte aligned.

Bit	Description
31:5	Link Pointer Low (LPL) — R/W. These bits correspond to memory address signals [31:5], respectively. This field may only reference a Queue Head (QH).
4:0	Reserved. These bits are reserved and their value has no effect on operation.

12.2.2.8 CONFIGFLAG—Configure Flag Register

Offset: CAPLENGTH + 40–43h Attribute: R/W
 Default Value: 00000000h Size: 32 bits

This 32-bit register contains the address of the next asynchronous queue head to be executed. Since the ICH4 host controller operates in 64-bit mode (as indicated by a one in 64-bit Addressing Capability field in the HCCPARAMS register), then the most significant 32 bits of every control data structure address comes from the CTRLDSSEGMENT register. Bits [4:0] of this register cannot be modified by system software and will always return zeros when read. The memory structure referenced by this physical memory pointer is assumed to be 32-byte aligned.

Bit	Description
31:1	Reserved. Read from this field will always return 0.
0	Configure Flag (CF) — R/W. Host software sets this bit as the last action in its process of configuring the Host controller. This bit controls the default port-routing control logic. Bit values and side-effects are listed below. For operation details, see Chapter 4 of the <i>Enhanced Host Controller Interface (EHCI) Specification for Universal Serial Bus</i> . 0 = Port routing control logic default-routes each port to the classic host controllers. (Default) 1 = Port routing control logic default-routes all ports to this host controller.

12.2.2.9 PORTSC—Port N Status and Control Register

Offset:	Port 0	CAPLENGTH + 44–47h	
	Port 1	CAPLENGTH + 48–4Bh	
	Port 2	CAPLENGTH + 4C–4Fh	
	Port 3	CAPLENGTH + 50–53h	
	Port 4	CAPLENGTH + 54–57h	
	Port 5	CAPLENGTH + 58–5Bh	
Attribute:	R/W, R/WC, RO		
Default Value:	00003000h	Size:	32 bits

A host controller must implement one or more port registers. Software uses the N_Port information from the Structural Parameters Register to determine how many ports need to be serviced. All ports have the structure defined below. Software must not write to unreported Port Status and Control Registers.

This register is in the suspend power well. It is only reset by hardware when the suspend power is initially applied or in response to a host controller reset. The initial conditions of a port are:

- No device connected,
- Port disabled.

When a device is attached, the port state transitions to the attached state and system software will process this as with any status change notification. Refer to Chapter 4 of the *Enhanced Host Controller Interface (EHCI) Specification for Universal Serial Bus* for operational requirements for how change events interact with port suspend mode.

Bit	Description																
31:23	Reserved. These bits are reserved for future use and will return a value of 0s when read.																
22	Wake on Over-current Enable (WKOC_E) — RW. 0 = Disable. (Default) 1 = Enable. Writing this bit to a 1 enables the setting of the PME Status bit in the Power Management Control/Status Register (offset 54, bit 15) when the Over-current Active bit (bit 4 of this register) is set to 1.																
21	Wake on Disconnect Enable (WKDSCNNT_E) — RW. Default = 0b. 0 = Disable. (Default) 1 = Enable. Writing this bit to a 1 enables the setting of the PME Status bit in the Power Management Control/Status Register (offset 54, bit 15) when the Current Connect Status changes from connected to disconnected (i.e., bit 0 of this register changes from 1 to 0).																
20	Wake on Connect Enable (WKCNTT_E) — RW. 0 = Disable. (Default) 1 = Enable. Writing this bit to a 1 enables the setting of the PME Status bit in the Power Management Control/Status Register (offset 54, bit 15) when the Current Connect Status changes from disconnected to connected (i.e., bit 0 of this register changes from 0 to 1).																
19:16	Port Test Control — RW. When this field is 0, the port is NOT operating in a test mode. A non-zero value indicates that it is operating in test mode and the specific test mode is indicated by the specific value. Refer to <i>Universal Serial Bus (USB) Specification, Revision 2.0</i> , Chapter 7 for details on each test mode. <table> <thead> <tr> <th>Bits</th> <th>Test Mode</th> </tr> </thead> <tbody> <tr> <td>0000</td> <td>Test mode Not enabled (Default)</td> </tr> <tr> <td>0001</td> <td>Test J_STATE</td> </tr> <tr> <td>0010</td> <td>Test K_STATE</td> </tr> <tr> <td>0011</td> <td>Test SEO_NAK</td> </tr> <tr> <td>0100</td> <td>Test Packet</td> </tr> <tr> <td>0101</td> <td>Test FORCE_ENABLE</td> </tr> <tr> <td>0110–1111</td> <td>Reserved</td> </tr> </tbody> </table>	Bits	Test Mode	0000	Test mode Not enabled (Default)	0001	Test J_STATE	0010	Test K_STATE	0011	Test SEO_NAK	0100	Test Packet	0101	Test FORCE_ENABLE	0110–1111	Reserved
Bits	Test Mode																
0000	Test mode Not enabled (Default)																
0001	Test J_STATE																
0010	Test K_STATE																
0011	Test SEO_NAK																
0100	Test Packet																
0101	Test FORCE_ENABLE																
0110–1111	Reserved																

Bit	Description								
15:14	Reserved — RW. Should be written to =00b.								
13	<p>Port Owner — RW. Default = 1b. This bit unconditionally goes to a 0 when the Configured Flag bit in the CONFIGFLAG register makes a 0-to-1 transition.</p> <p>System software uses this field to release ownership of the port to a selected host controller (in the event that the attached device is not a high-speed device). Software writes a 1 to this bit when the attached device is not a high-speed device. A 1 in this bit means that a companion host controller owns and controls the port. For operational details, see Chapter 4 of the <i>Enhanced Host Controller Interface (EHCI) Specification for Universal Serial Bus</i>.</p>								
12	<p>Port Power (PP) — RO. Hardwired to 1. This indicates that the port does have power.</p>								
11:10	<p>Line Status — RO. These bits reflect the current logical levels of the D+ (bit 11) and D- (bit 10) signal lines. These bits are used for detection and enable sequence. This field is valid only when the port enable bit is 0 and the current connect status bit is set to a 1.</p> <p>00 = SE0 10 = J-state 01 = K-state 11 = Undefined</p>								
9	Reserved. This bit will return a 0 when read.								
8	<p>Port Reset — RW. When software writes a 1 to this bit (from a 0), the bus reset sequence as defined in the <i>Universal Serial Bus (USB) Specification, Revision 2.0</i> is started. Software writes a 0 to this bit to terminate the bus reset sequence. Software must keep this bit at a 1 long enough to ensure the reset sequence completes, as specified in the <i>Universal Serial Bus (USB) Specification, Revision 2.0</i>.</p> <p>0 = Port is not in Reset. (Default) 1 = Port is in Reset.</p> <p>NOTE: When software writes this bit to a 1, it must also write a 0 to the Port Enable bit. When software writes a 0 to this bit, there may be a delay before the bit status changes to a 0. The bit status will not read as a 0 until after the reset has completed. If the port is in high-speed mode after reset is complete, the host controller will automatically enable this port (e.g., set the Port Enable bit to a 1). A host controller must terminate the reset and stabilize the state of the port within 2 milliseconds of software transitioning this bit from 1 to 0.</p> <p>For example: if the port detects that the attached device is high-speed during reset, then the host controller must have the port in the enabled state within 2 ms of software writing this bit to a 0. The HCHalted bit in the EHCI_STS register should be a 0 before software attempts to use this bit. The host controller may hold Port Reset asserted to a 1 when the HCHalted bit is a 1. This field is 0 if Port Power is 0.</p> <p>Warning: System software should not attempt to reset a port if the HCHalted bit in the EHCI_STS register is a 1. Doing so will result in undefined behavior.</p>								
7	<p>Suspend — RW.</p> <p>0 = Port not in suspend state. (Default). 1 = Port in suspend state.</p> <p>Port Enabled Bit and Suspend bit of this register define the port states as follows:</p> <table border="1"> <thead> <tr> <th>Bits [Port Enabled, Suspend]</th> <th>Port State</th> </tr> </thead> <tbody> <tr> <td>0X</td> <td>Disable</td> </tr> <tr> <td>10</td> <td>Enable</td> </tr> <tr> <td>11</td> <td>Suspend</td> </tr> </tbody> </table> <ul style="list-style-type: none"> When in suspend state, downstream propagation of data is blocked on this port, except for port reset. Note that the bit status does not change until the port is suspended and that there may be a delay in suspending a port depending on the activity on the port. The host controller will unconditionally set this bit to a 0 when software sets the <i>Force Port Resume</i> bit to a 0 (from a 1). A write of 0 to this bit is ignored by the host controller. If host software sets this bit to a 1 when the port is not enabled (i.e., Port enabled bit is a 0) the results are undefined. 	Bits [Port Enabled, Suspend]	Port State	0X	Disable	10	Enable	11	Suspend
Bits [Port Enabled, Suspend]	Port State								
0X	Disable								
10	Enable								
11	Suspend								

Bit	Description
6	<p>Force Port Resume — RW. Software sets this bit to a 1 to drive resume signaling. The Host controller sets this bit to a 1 if a J-to-K transition is detected while the port is in the Suspend state. When this bit transitions to a 1 because a J-to-K transition is detected, the Port Change Detect bit in the EHCI_STS register is also set to a 1. If software sets this bit to a 1, the host controller must not set the Port Change Detect bit.</p> <p>0 = No resume (K-state) detected/driven on port. (Default). 1 = Resume detected/driven on port.</p> <p>NOTE: When the EHCI controller owns the port, the resume sequence follows the defined sequence documented in the <i>Universal Serial Bus (USB) Specification, Revision 2.0</i>. The resume signaling (Full-speed 'K') is driven on the port as long as this bit remains a 1. Software must appropriately time the Resume and set this bit to a 0 when the appropriate amount of time has elapsed. Writing a 0 (from 1) causes the port to return to high-speed mode (forcing the bus below the port into a high-speed idle). This bit will remain 1 until the port has switched to the high-speed idle.</p>
5	<p>Overcurrent Change— R/WC. Default = 0. The functionality of this bit is not dependent upon the port owner.</p> <p>0 = Software clears this bit by writing a 1 to this bit position. 1 = There is a change to Over-current Active.</p>
4	<p>Overcurrent Active — RO. The ICH4 automatically disables the port when the over-current active bit is 1.</p> <p>0 = This port does not have an over-current condition. This bit will automatically transition from a 1-to-0 when the over current condition is removed. (Default) 1 = This port currently has an over-current condition.</p>
3	<p>Port Enable/Disable Change — R/WC. For the root hub, this bit gets set to a 1 only when a port is disabled due to the appropriate conditions existing at the EOF2 point (See Chapter 11 of the <i>Universal Serial Bus (USB) Specification, Revision 2.0</i> for the definition of a port error). This bit is not set due to the Disabled-to-Enabled transition, nor due to a disconnect.</p> <p>0 = No change in status. (Default). Software clears this bit by writing a 1 to it. 1 = Port enabled/disabled status has changed.</p>
2	<p>Port Enabled/Disabled — R/W. Ports can only be enabled by the host controller as a part of the reset and enable. Software cannot enable a port by writing a 1 to this field. Ports can be disabled by either a fault condition (disconnect event or other fault condition) or by host software. Note that the bit status does not change until the port state actually changes. There may be a delay in disabling or enabling a port due to other host controller and bus events.</p> <p>0 = Disable. (Default) 1 = Enable.</p>
1	<p>Connect Status Change — R/WC. A 1 indicates a change has occurred in the port's Current Connect Status. The host controller sets this bit for all changes to the port device connect status, even if system software has not cleared an existing connect status change. For example, the insertion status changes twice before system software has cleared the changed condition, hub hardware will be "setting" an already-set bit (i.e., the bit will remain set).</p> <p>0 = No change. (Default). Software sets this bit to 0 by writing a 1 to it. 1 = Change in Current Connect Status.</p>
0	<p>Current Connect Status — RO. This value reflects the current state of the port, and may not correspond directly to the event that caused the Connect Status Change bit (Bit 1) to be set.</p> <p>0 = No device is present. (Default) 1 = Device is present on port.</p>

12.2.3 USB 2.0-Based Debug Port Register

The Debug port's registers are located in the same memory area, defined by the Base Address Register (BAR), as the standard EHCI registers. The base offset for the debug port registers (80h) is declared in the Debug Port Base Offset Capability Register at Configuration offset 5Ah. The specific EHCI port that supports this debug capability is indicated by a 4-bit field (bits 20–23) in the HCSPARAMS register of the EHCI controller.

The map of the Debug Port registers is shown in [Table 12-4](#). Each register is defined individually below.

Table 12-4. Debug Port Register Address Map

Offset	Register Name	Type
00h	Control/Status	R/W, RO
04h	USB PIDs	R/W, RO
08h	Data Buffer (Bytes 3:0)	R/W
0Ch	Data Buffer (Bytes 7:4)	R/W
10h	Config Register	R/W

NOTES:

- All of these registers are implemented in the core well and reset by PCIRST#, EHC HCRESET, and a EHC D3-to-D0 transition.
- The hardware associated with this register provides no checks to ensure that software programs the interface correctly. How the hardware behaves when programmed illegally is undefined.

12.2.3.1 Control/Status Register

Offset: 00h Attribute: R/W, RO
 Default Value: 00000000h Size: 32 bits

Note: Software should do Read-Modify-Write operations to this register to preserve the contents of bits not being modified. This include Reserved bits.

Note: To preserve the usage of RESERVED bits in the future, software should always write the same value read from the bit until it is defined. Reserved bits will always return 0 when read.

Bit	Description
31	Reserved
30	OWNER_CNT — R/W. 0 = Default. 1 = Ownership of the debug port is forced to the EHCI controller (i.e., immediately taken away from the companion Classic USB Host controller). If the port was already owned by the EHCI controller, then setting this bit has no effect. This bit overrides all of the ownership-related bits in the standard EHCI registers.
29	Reserved

Bit	Description
28	<p>ENABLED_CNT — R/W.</p> <p>0 = Software can clear this bit by writing a 0 to it. Hardware clears the bit for the same conditions where the Port Enable/Disable Change bit (in the PORTSC register) is set. (Default)</p> <p>1 = Enable debug port for operation. Software can directly set this bit if the port is already enabled in the associated Port Status and Control register (this is enforced by the hardware).</p>
27:17	Reserved
16	<p>DONE_STS — R/WC.</p> <p>0 = Not Done (Default). Software clears this bit by writing a 1 to it.</p> <p>1 = This bit is set by hardware to indicate that the request is complete.</p>
15:12	<p>LINK_ID_STS — RO. Hardwired to 0000. This field identifies the link interface. It is hardwired to 0h to indicate that it is a USB Debug Port.</p>
11	Reserved. This bit will return 0 when read. Writes will have no effect.
10	<p>IN_USE_CNT — R/W. (This bit has no affect on hardware.)</p> <p>0 = Not in Use. Cleared by software to indicate that the port is free and may be used by other software. (Default)</p> <p>1 = In Use. Set by software to indicate that the port is in use.</p>
9:7	<p>EXCEPTION_STS — RO. Default=000b This field indicates the exception when the ERROR_GOOD#_STS bit is set. This field should be ignored if the ERROR_GOOD#_STS bit is 0.</p> <p>000 =No Error. Note: this should not be seen, since this field should only be checked if there is an error.</p> <p>001 =Transaction error: indicates the USB EHCI transaction had an error (CRC, bad PID, timeout, etc.)</p> <p>010 =HW error. Request was attempted (or in progress) when port was suspended or reset.</p> <p>All Others = Reserved</p>
6	<p>ERROR_GOOD#_STS — RO.</p> <p>0 = Hardware clears this bit upon the proper completion of a read or write. (Default)</p> <p>1 = Error Occurred. The hardware sets this bit to indicate that an error has occurred. Details on the nature of the error are provided in the Exception field.</p>
5	<p>GO_CNT — WO.</p> <p>0 = Hardware clears this bit when hardware sets the DONE_STS bit. (Default)</p> <p>1 = Causes hardware to perform a read or write request. Writing a 1 to this bit when it is already set may result in undefined behavior.</p>
4	<p>WRITE_READ#_CNT — R/W.</p> <p>0 = Read. Software clears this bit to indicate that the current request is a read. (Default)</p> <p>1 = Write. Software sets this bit to indicate that the current request is a write.</p>
3:0	<p>DATA_LEN_CNT — R/W. This field is used to indicate the size of the data to be transferred. (default = 0h).</p> <p>For <i>write</i> operations, this field is set by software to indicate to the hardware how many bytes of data in Data Buffer are to be transferred to the console. A value of 0h indicates that a zero-length packet should be sent. A value of 1–8h indicates 1–8 bytes are to be transferred. Values 9–Fh are illegal and how hardware behaves if used is undefined.</p> <p>For <i>read</i> operations, this field is set by hardware to indicate to software how many bytes in Data Buffer are valid in response to a read operation. A value of 0h indicates that a zero length packet was returned and the state of Data Buffer is not defined. A value of 1–8 indicates 1–8 bytes were received. Hardware does not return values 9–Fh.</p> <p>The transferring of data always starts with byte 0 in the data area and moves toward byte 7 until the transfer size is reached.</p>

12.2.3.2 USB PIDs Register

Offset: 04h Attribute: R/W, RO
 Default Value: 00000000h Size: 32 bits

This DWord register is used to communicate PID information between the USB debug driver and the USB debug port. The debug port uses some of these fields to generate USB packets, and uses other fields to return PID information to the USB debug driver.

Bit	Description
31:24	Reserved. These bits will return 0 when read. Writes will have no effect.
23:16	RECEIVED_PID_STS [23:16] — RO. The hardware updates this field with the received PID for transactions in either direction. When the controller is writing data, this field is updated with the handshake PID that is received from the device. When the host controller is reading data, this field is updated with the data packet PID (if the device sent data), or the handshake PID (if the device NAKs the request). This field is valid when the hardware clears the GO_DONE#_CNT bit.
15:8	SEND_PID_CNT [15:8] — R/W. The hardware sends this PID to begin the data packet when sending data to USB (i.e., WRITE_READ#_CNT is asserted). Software will typically set this field to either DATA0 or DATA1 PID values.
7:0	TOKEN_PID_CNT [7:0] — R/W. Hardware sends this PID as the Token PID for each USB transaction. Software typically sets this field to either IN, OUT, or SETUP PID values.

12.2.3.3 Data Buffer Bytes 7:0 Register

Offset: 08h Attribute: R/W
 Default Value: 0000000000000000h Size: 64 bits

This register can be accessed as 8 separate 8-bit registers or 2 separate 32-bit register.

Bit	Description
63:0	DATA_BUFFER [63:0] — R/W. These are the 8 bytes of the data buffer. The bytes in the Data Buffer must be written with data before software initiates a write request. For a read request, the Data Buffer contains valid data when DONE_STS bit is cleared by the hardware, ERROR_GOOD#_STS is cleared by the hardware, and the DATA_LENGTH_CNT field indicates the number of bytes that are valid. Bits 63:56 Correspond to the most significant byte (byte 7). Bits 7:0 Correspond to least significant byte (byte 0).

12.2.3.4 Configuration Register

Offset: 10h Attribute: R/W
Default Value: 00007F01h Size: 32 bits

Bit	Description
31:15	Reserved
14:8	USB_ADDRESS_CNF — R/W. This 7-bit field that identifies the USB device address used by the controller for all Token PID generation. (Default = 7Fh)
7:4	Reserved
3:0	USB_ENDPOINT_CNF — R/W. This 4-bit field identifies the endpoint used by the controller for all Token PID generation. (Default=01h)

13.1.3 CMD—Command Register (SMBUS—D31:F3)

Address: 04–05h Attributes: RO R/W
 Default Value: 0000h Size: 16 bits

Bit	Description
15:10	Reserved
9	Fast Back to Back Enable (FBE) — RO. Reserved as 0.
8	SERR# Enable (SERR_EN) — RO. Reserved as 0.
7	Wait Cycle Control (WCC) — RO. Reserved as 0.
6	Parity Error Response (PER) — RO. Reserved as 0.
5	VGA Palette Snoop (VPS) — RO. Reserved as 0.
4	Postable Memory Write Enable (PMWE) — RO. Reserved as 0.
3	Special Cycle Enable (SCE) — RO. Reserved as 0.
2	Bus Master Enable (BME) — RO. Reserved as 0.
1	Memory Space Enable (MSE) — RO. Reserved as 0.
0	I/O Space Enable (IOSE) — R/W. 0 = Disable 1 = Enables access to the SM Bus I/O space registers as defined by the Base Address Register.

13.1.4 STA—Device Status Register (SMBUS—D31:F3)

Address: 06–07h Attributes: RO R/W
 Default Value: 0280h Size: 16 bits

Bit	Description
15	Detected Parity Error (DPE) — RO. Reserved as 0.
14	Signaled System Error (SSE) — RO. Reserved as 0.
13	Received Master Abort (RMA) — RO. Reserved as 0.
12	Received Target Abort (RTA) — RO. Reserved as 0.
11	Signaled Target Abort (STA) — R/W. Set when the function is targeted with a transaction that the ICH4 terminates with a target abort. Software resets STA to 0 by writing a 1 to this bit location.
10:9	DEVSEL# Timing Status (DEV_STS) — RO. This 2-bit field defines the timing for DEVSEL# assertion for positive decode. 01 = Medium timing.
8	Data Parity Error Detected (DPED) — RO. Reserved as 0.
7	Fast Back to Back Capable (FB2BC) — RO. Reserved as 1.
6	User Definable Features (UDF) — RO. Reserved as 0.
5	66 MHz Capable (66MHZ_CAP) — RO. Reserved as 0.
4:0	Reserved

13.1.9 SVID — Subsystem Vendor ID (SMBUS—D31:F2/F4)

Address Offset: 2Ch–2Dh Attribute: RO
 Default Value: 00h Size: 16 bits
 Lockable: No Power Well: Core

Bit	Description
15:0	Subsystem Vendor ID (SVID) — RO. The SVID register, in combination with the Subsystem ID (SID) register, enables the operating system (OS) to distinguish subsystems from each other. The value returned by reads to this register is the same as that which was written by BIOS into the IDE_SVID register.

13.1.10 SID — Subsystem ID (SMBUS—D31:F2/F4)

Address Offset: 2Eh–2Fh Attribute: RO
 Default Value: 00h Size: 16 bits
 Lockable: No Power Well: Core

Bit	Description
15:0	Subsystem ID (SID) — R/Write-Once. The SID register, in combination with the SVID register, enables the operating system (OS) to distinguish subsystems from each other. The value returned by reads to this register is the same as that which was written by BIOS into the IDE_SID register.

13.1.11 INTR_LN—Interrupt Line Register (SMBUS—D31:F3)

Address Offset: 3Ch Attributes: R/W
 Default Value: 00h Size: 8 bits

Bit	Description
7:0	Interrupt Line (INT_LN) — R/W. This data is not used by the ICH4. It is to communicate to software the interrupt line that the interrupt pin is connected to PIRQB#.

13.1.12 INTR_PN—Interrupt Pin Register (SMBUS—D31:F3)

Address Offset: 3Dh Attributes: RO
 Default Value: 02h Size: 8 bits

Bit	Description
7:0	Interrupt Pin (INT_PN) — RO. 02h = Indicates that the ICH4 SMBus controller will drive PIRQB# as its interrupt line.

Bit	Description
6	<p>INUSE_STS — R/WC (special). This bit is used as semaphore among various independent software threads that may need to use the ICH4's SMBus logic, and has no other effect on hardware.</p> <p>0 = After a full PCI reset, a read to this bit returns a 0.</p> <p>1 = After the first read, subsequent reads will return a 1. A write of a 1 to this bit will reset the next read value to 0. Writing a 0 to this bit has no effect. Software can poll this bit until it reads a 0, and will then own the usage of the host controller.</p>
5	<p>SMBALERT_STS — R/WC. If the signal is programmed as a GPIO, then this bit will never be set.</p> <p>0 = Interrupt or SMI# was not generated by SMBALERT#. This bit is only cleared by software writing a 1 to the bit position or by RSMRST# going low.</p> <p>1 = The source of the interrupt or SMI# was the SMBALERT# signal.</p>
4	<p>FAILED — R/WC.</p> <p>0 = Cleared by writing a 1 to the bit position.</p> <p>1 = The source of the interrupt or SMI# was a failed bus transaction. This bit is set in response to the KILL bit being set to terminate the host transaction.</p>
3	<p>BUS_ERR — R/WC.</p> <p>0 = Cleared by writing a 1 to the bit position.</p> <p>1 = The source of the interrupt of SMI# was a transaction collision.</p>
2	<p>DEV_ERR — R/WC.</p> <p>0 = Software resets this bit by writing a 1 to this location. The ICH4 will then deassert the interrupt or SMI#.</p> <p>1 = The source of the interrupt or SMI# was due to one of the following:</p> <ul style="list-style-type: none"> • Illegal Command Field, • Unclaimed Cycle (host initiated), • Host Device Time-out Error.
1	<p>INTR — R/WC (special). This bit can only be set by termination of a command. INTR is not dependent on the INTREN bit of the Host Controller Register (offset 02h). It is only dependent on the termination of the command. If the INTREN bit is not set, then the INTR bit will be set, although the interrupt will not be generated. Software can poll the INTR bit in this non-interrupt case.</p> <p>0 = Software resets this bit by writing 1 to this location. The ICH4 will then deassert the interrupt or SMI#.</p> <p>1 = The source of the interrupt or SMI# was the successful completion of its last command.</p>
0	<p>HOST_BUSY — RO.</p> <p>0 = Cleared by the ICH4 when the current transaction is completed.</p> <p>1 = Indicates that the ICH4 is running a command from the host interface. No SMB registers should be accessed while this bit is set, except the BLOCK DATA BYTE Register. The BLOCK DATA BYTE Register can be accessed when this bit is set only when the SMB_CMD bits in the Host Control Register are programmed for Block command or I²C Read command. This is necessary in order to check the DONE_STS bit.</p>

13.2.2 HST_CNT—Host Control Register

Register Offset: 02h Attribute: R/W, WO
 Default Value: 00h Size: 8-bits

Note: A read to this register will clear the byte pointer of the 32-byte buffer.

Bit	Description
7	<p>PEC_EN — R/W.</p> <p>0 = SMBus host controller does not perform the transaction with the PEC phase appended.</p> <p>1 = Causes the host controller to perform the SMBus transaction with the Packet Error Checking phase appended. For writes, the value of the PEC byte is transferred from the PEC Register. For reads, the PEC byte is loaded in to the PEC Register. This bit must be written prior to the write in which the START bit is set.</p>
6	<p>START — WO.</p> <p>0 = This bit will always return 0 on reads. The HOST_BUSY bit in the Host Status register (offset 00h) can be used to identify when the ICH4 has finished the command.</p> <p>1 = Writing a 1 to this bit initiates the command described in the SMB_CMD field. All registers should be setup prior to writing a 1 to this bit position.</p>
5	<p>LAST_BYTE — WO. This bit is used for Block Read commands.</p> <p>1 = Software sets this bit to indicate that the next byte will be the last byte to be received for the block. This causes the ICH4 to send a NACK (instead of an ACK) after receiving the last byte.</p> <p>NOTE: Once the SECOND_TO_STS bit in TCO2_STS register (D31:F0, TCOBASE+6h, bit 1) is set, the LAST_BYTE bit also gets set. While the SECOND_TO_STS bit is set, the LAST_BYTE bit cannot be cleared. This prevents the ICH4 from running some of the SMBus commands (Block Read/Write, I²C Read, Block I²C Write).</p>
4:2	<p>SMB_CMD — R/W. The bit encoding below indicates which command the ICH4 is to perform. If enabled, the ICH4 will generate an interrupt or SMI# when the command has completed. If the value is for a non-supported or reserved command, the ICH4 will set the device error (DEV_ERR) status bit and generate an interrupt when the START bit is set. The ICH4 will perform no command, and will not operate until DEV_ERR is cleared.</p> <p>000 = Quick: The slave address and read/write value (bit 0) are stored in the transmit slave address register.</p> <p>001 = Byte: This command uses the transmit slave address and command registers. Bit 0 of the slave address register determines if this is a read or write command.</p> <p>010 = Byte Data: This command uses the transmit slave address, command, and DATA0 registers. Bit 0 of the slave address register determines if this is a read or write command. If it is a read, the DATA0 register will contain the read data.</p> <p>011 = Word Data: This command uses the transmit slave address, command, DATA0 and DATA1 registers. Bit 0 of the slave address register determines if this is a read or write command. If it is a read, after the command completes, the DATA0 and DATA1 registers will contain the read data.</p> <p>100 = Process Call: This command uses the transmit slave address, command, DATA0 and DATA1 registers. Bit 0 of the slave address register determines if this is a read or write command. After the command completes, the DATA0 and DATA1 registers will contain the read data.</p> <p>101 = Block: This command uses the transmit slave address, command, DATA0 registers, and the Block Data Byte register. For block write, the count is stored in the DATA0 register and indicates how many bytes of data will be transferred. For block reads, the count is received and stored in the DATA0 register. Bit 0 of the slave address register selects if this is a read or write command. For writes, data is retrieved from the first n (where n is equal to the specified count) addresses of the SRAM array. For reads, the data is stored in the Block Data Byte register.</p> <p>110 = I²C Read: This command uses the transmit slave address, command, DATA0, DATA1 registers, and the Block Data Byte register. The read data is stored in the Block Data Byte register. The ICH4 will continue reading data until the NAK is received.</p> <p>111 = Reserved</p>

13.2.9 RCV_SLVA—Receive Slave Address Register

Register Offset:	09h	Attribute:	R/W
Default Value:	44h	Size:	8 bits
Lockable:	No	Power Well:	Resume

Bit	Description
7	Reserved
6:0	SLAVE_ADDR — R/W. This field is the slave address that the ICH4 decodes for read and write cycles. the default is not 0, so the SMBus Slave Interface can respond even before the processor comes up (or if the processor is dead). This register is cleared by RSMRST#, but not by PCIRST#.

13.2.10 SLV_DATA—Receive Slave Data Register

Register Offset:	0Ah	Attribute:	RO
Default Value:	0000h	Size:	16 bits
Lockable:	No	Power Well:	Resume

This register contains the 16-bit data value written by the external SMBus master. The processor can then read the value from this register. This register is reset by RSMRST#, but not PCIRST#.

Bit	Description
15:8	Data Message Byte 1 (DATA_MSG1) — RO. See Section 5.18.7 for a discussion of this field.
7:0	Data Message Byte 0 (DATA_MSG0) — RO. See Section 5.18.7 for a discussion of this field.

13.2.11 AUX_STS—Auxiliary Status Register

Register Offset:	0Ch	Attribute:	RW/C
Default Value:	00h	Size:	8 bits
Lockable:	No	Power Well:	Resume

Bit	Description
7:1	Reserved
0	CRC Error (CRCE) — R/WC. 0 = Software clears this bit by writing a 1 to it. 1 = This bit is set if a received message contained a CRC error. When this bit is set, the DERR bit of the host status register will also be set. This bit will be set by the controller if a software abort occurs in the middle of the CRC portion of the cycle or an abort happens after the ICH4 has received the final data bit transmitted by an external slave.

13.2.12 AUX_CTL—Auxiliary Control Register

Register Offset:	0Dh	Attribute:	R/W
Default Value:	00h	Size:	8 bits
Lockable:	No	Power Well:	Resume

Bit	Description
7:2	Reserved
1	Enable 32-byte Buffer (E32B) — R/W. 0 = Disable. 1 = Enable. The Host Block Data register is a pointer into a 32-byte buffer, as opposed to a single register. This enables the block commands to transfer or receive up to 32-bytes before the ICH4 generates an interrupt.
0	Automatically Append CRC (AAC) — R/W. 0 = Disable. 1 = Enable. The ICH4 automatically appends the CRC. This bit must not be changed during SMBus transactions, or undetermined behavior will result

13.2.13 SMLINK_PIN_CTL—SMLink Pin Control Register

Register Offset:	0Eh	Attribute:	R/W, RO
Default Value:	See below	Size:	8 bits

Note: This register is in the resume well and is reset by RSMRST#.

Bit	Description
7:3	Reserved
2	SMLINK_CLK_CTL — R/W. 0 = ICH4 drives the SMLINK[0] pin low, independent of what the other SMLINK logic would otherwise indicate for the SMLINK[0] pin. 1 = The SMLINK[0] pin is not overdriven low. The other SMLINK logic controls the state of the pin. (Default)
1	SMLINK1_CUR_STS — R/W. This pin returns the value on the SMLINK[1] pin. This allows software to read the current state of the pin. Default value is dependent on an external signal level. 0 = Low 1 = High
0	SMLINK0_CUR_STS — RO. This pin returns the value on the SMLINK[0] pin. This allows software to read the current state of the pin. Default value is dependent on an external signal level. 0 = Low 1 = High

13.2.14 SMBUS_PIN_CTL—SMBUS Pin Control Register

Register Offset: 0Fh Attribute: R/W, RO
 Default Value: See below Size: 8 bits

Note: This register is in the resume well and is reset by RSMRST#.

Bit	Description
7:3	Reserved
2	SMBCLK_CTL — R/W. 0 = ICH4 will drive the SMBCLK pin low, independent of what the other SMB logic would otherwise indicate for the SMBCLK pin. 1 = The SMBCLK pin is not overdriven low. The other SMBus logic controls the state of the pin. (Default)
1	SMBDATA_CUR_STS — RO. This pin returns the value on the SMBDATA pin. This allows software to read the current state of the pin. Default value is dependent on an external signal level. 0 = Low 1 = High
0	SMBCLK_CUR_STS — RO. This pin returns the value on the SMBCLK pin. This allows software to read the current state of the pin. Default value is dependent on an external signal level. 0 = Low 1 = High

13.2.15 SLV_STS—Slave Status Register

Register Offset: 10h Attribute: R/WC
 Default Value: 00h Size: 8 bits

Note: This register is in the resume well and is reset by RSMRST#.

All bits in this register are implemented in the 64 kHz clock domain. Therefore, software must poll this register until a write takes effect before assuming that a write has completed internally.

Bit	Description
7:1	Reserved
0	HOST_NOTIFY_STS — R/WC. The ICH4 sets this bit to a 1 when it has completely received a successful Host Notify Command on the SMLink pins. Software reads this bit to determine that the source of the interrupt or SMI# was the reception of the Host Notify Command. Software clears this bit after reading any information needed from the Notify address and data registers by writing a 1 to this bit. Note that the ICH4 will allow the Notify Address and Data registers to be over-written once this bit has been cleared. When this bit is 1, the ICH4 will NACK the first byte (host address) of any new “Host Notify” commands on the SMLink. Writing a 0 to this bit has no effect.



13.2.18 NOTIFY_DLOW—Notify Data Low Byte Register

Register Offset:	16h	Attribute:	RO
Default Value:	00h	Size:	8 bits

Note: This register is in the resume well and is reset by RSMRST#

Bit	Description
7:0	DATA_LOW_BYTE — RO. This field contains the first (low) byte of data received during the Host Notify protocol of the SMBus 2.0 Specification. Software should only consider this field valid when the HOST_NOTIFY_STS bit is set to 1.

13.2.19 NOTIFY_DHIGH—Notify Data High Byte Register

Register Offset:	17h	Attribute:	RO
Default Value:	00h	Size:	8 bits

Note: This register is in the resume well and is reset by RSMRST#

Bit	Description
7:0	DATA_HIGH_BYTE — RO. This field contains the second (high) byte of data received during the Host Notify protocol of the SMBus 2.0 Specification. Software should only consider this field valid when the HOST_NOTIFY_STS bit is set to 1.

This page is intentionally left blank.

AC '97 Audio Controller Registers (D31:F5)

14

14.1 AC '97 Audio PCI Configuration Space (D31:F5)

Note: Registers address locations not shown in Table 14-1 should be treated as Reserved.

Table 14-1. AC '97 Audio PCI Configuration Register Address Map (Audio—D31:F5)

Offset	Mnemonic	Register	Default	Access
00–01h	VID	Vendor Identification	8086h	RO
02–03h	DID	Device Identification	24C5h	RO
04–05h	PCICMD	PCI Command	0000	R/W, RO
06–07h	PCISTS	PCI Device Status	0280h	R/WC, RO
08h	RID	Revision Identification	See Note	RO
09h	PI	Programming Interface	00	RO
0Ah	SCC	Sub Class Code	01h	RO
0Bh	BCC	Base Class Code	04h	RO
0Eh	HEDT	Header Type	00	RO
10–13h	NAMBBAR	Native Audio Mixer Base Address	00000001h	R/W, RO
14–17h	NAMBBAR	Native Audio Bus Mastering Base Address	00000001h	R/W, RO
18–1Bh	MMBAR	Mixer Base Address(Mem)	00000000h	R/W, RO
1C–1Fh	MBBAR	Bus Master Base Address(Mem)	00000000h	R/W, RO
2C–2Dh	SVID	Subsystem Vendor ID	0000h	R/WO
2E–2Fh	SID	Subsystem ID	0000h	R/WO
34h	CAP_PTR	Capabilities Pointer	50h	RO
3Ch	INTR_LN	Interrupt Line	00h	R/W
3Dh	INTR_PN	Interrupt Pin	02h	RO
40h	PCID	Programmable Codec ID	01h	R/W
41h	CFG	Configuration	00h	R/W
50–51h	PID	PCI Power Management ID	0001h	RO
52–53h	PC	PC -Power Management Capabilities	C9C2h	RO
54–55h	PCS	Power Management Control and Status	0000h	R/W, R/WC

NOTE: Refer to the ICH4 Specification Update for the value of the Revision ID Register.

Note: Internal reset as a result of D3_{HOT} to D0 transition will reset all the core well registers except the following BIOS programmed registers as BIOS may not be invoked following the D3-to-D0 transition. All resume well registers will not be reset by the D3_{HOT} to D0 transition.

Core Well registers **not** reset by the D3_{HOT} to D0 transition:

- offset 2Ch–2Dh: Subsystem Vendor ID (SVID)
- offset 2Eh–2Fh: Subsystem ID (SID)
- offset 40h: Programmable Codec ID (PCID)
- offset 41h: Configuration (CFG)

Resume Well registers will **NOT** be reset by the D3_{HOT} to D0 transition:

- offset 54h–55h: Power Management Control and Status (PCS)
- Bus Mastering Register: Global Status Register, bits 17:16
- Bus Mastering Register: SDATA_IN MAP register, bits 7:3

14.1.1 VID—Vendor Identification Register (Audio—D31:F5)

Offset:	00–01h	Attribute:	RO
Default Value:	8086h	Size:	16 Bits
Lockable:	No	Power Well:	Core

Bit	Description
15:0	Vendor Identification Value — RO. This is a 16-bit value assigned to Intel.

14.1.2 DID—Device Identification Register (Audio—D31:F5)

Offset:	02–03h	Attribute:	RO
Default Value:	24C5h	Size:	16 Bits
Lockable:	No	Power Well:	Core

Bit	Description
15:0	Device Identification Value — RO.

14.1.3 PCICMD—PCI Command Register (Audio—D31:F5)

Address Offset:	04–05h	Attribute:	R/W, RO
Default Value:	0000h	Size:	16 bits
Lockable:	No	Power Well:	Core

PCICMD is a 16-bit control register. Refer to the PCI 2.2 specification for complete details on each bit.

Bit	Description
15:10	Reserved. Read 0.
9	Fast Back to Back Enable (FBE) — RO. Not implemented. Hardwired to 0.
8	SERR# Enable (SERR_EN) — RO. Not implemented. Hardwired to 0.
7	Wait Cycle Control (WCC) — RO. Not implemented. Hardwired to 0.
6	Parity Error Response (PER) — RO. Not implemented. Hardwired to 0.
5	VGA Palette Snoop (VPS) — RO. Not implemented. Hardwired to 0.
4	Memory Write and Invalidate Enable (MWIE) — RO. Not implemented. Hardwired to 0.
3	Special Cycle Enable (SCE) — RO. Not implemented. Hardwired to 0.
2	Bus Master Enable (BME) — R/W. This bit controls standard PCI bus mastering capabilities. 0 = Disable (Default). 1 = Enable
1	Memory Space Enable (MSE) — R/W. This bit enables memory space addresses to the AC '97 Audio controller. (Default=0). 0 = Disable (Default) 1 = Enable
0	I/O Space Enable (IOSE) — R/W. This bit controls access to the AC '97 Audio controller I/O space registers. 0 = Disable (Default) 1 = Enable access to I/O space. The Native PCI Mode Base Address register should be programmed prior to setting this bit. NOTE: This bit becomes write-able when the IOSE bit in offset 41h is set. If at any point software decides to clear the IOSE bit, software must first clear the IOS bit first.

14.1.4 PCISTS—PCI Device Status Register (Audio—D31:F5)

Offset:	06–07h	Attribute:	R/WC, RO
Default Value	0280h	Size:	16 bits
Lockable:	No	Power Well:	Core

PCISTA is a 16-bit status register. Refer to the PCI 2.2 specification for complete details on each bit.

Bit	Description
15	Detected Parity Error (DPE) — RO. Not implemented. Hardwired to 0.
14	Signaled System Error (SSE) — RO. Not implemented. Hardwired to 0.
13	Master Abort Status (MAS) — R/WC. 0 = Software clears this bit by writing a 1 to the bit position. 1 = Bus Master AC '97 2.3 interface function, as a master, generates a master abort.
12	Reserved. Will always read as 0.
11	Signaled Target Abort (STA) — RO. Not implemented. Hardwired to 0.
10:9	DEVSEL# Timing Status (DEV_STS) — RO. This 2-bit field reflects the ICH4's DEVSEL# timing when performing a positive decode. 01b = Medium timing.
8	Data Parity Error Detected (DPED) — RO. Not implemented. Hardwired to 0.
7	Fast Back to Back Capable (FB2BC) — RO. Hardwired to 1. This bit indicates that the ICH4 as a target is capable of fast back-to-back transactions.
6	User Definable Features (UDF) — RO. Not implemented. Hardwired to 0.
5	66 MHz Capable (66MHZ_CAP) — RO. Hardwired to 0.
4	Capabilities List (CLIST) — RO. Indicates that the controller contains a capabilities pointer list. The first item is pointed to by looking at configuration offset 34h.
3:0	Reserved.

14.1.5 RID—Revision Identification Register (Audio—D31:F5)

Offset:	08h	Attribute:	RO
Default Value:	See Bit Description	Size:	8 Bits
Lockable:	No	Power Well:	Core

Bit	Description
7:0	Revision Identification Value — RO. Refer to the ICH4 Specification Update for the value of the Revision ID Register.

14.1.6 PI—Programming Interface Register (Audio—D31:F5)

Offset:	09h	Attribute:	RO
Default Value:	00h	Size:	8 bits
Lockable:	No	Power Well:	Core

Bit	Description
7:0	Programming Interface — RO.

14.1.7 SCC—Sub Class Code Register (Audio—D31:F5)

Address Offset:	0Ah	Attribute:	RO
Default Value:	01h	Size:	8 bits
Lockable:	No	Power Well:	Core

Bit	Description
7:0	Sub Class Code — RO. 01h = Audio Device

14.1.8 BCC—Base Class Code Register (Audio—D31:F5)

Address Offset:	0Bh	Attribute:	RO
Default Value:	04h	Size:	8 bits
Lockable:	No	Power Well:	Core

Bit	Description
7:0	Base Class Code — RO. 04h = Multimedia device

14.1.9 HEDT—Header Type Register (Audio—D31:F5)

Address Offset:	0Eh	Attribute:	RO
Default Value:	00h	Size:	8 bits
Lockable:	No	Power Well:	Core

Bit	Description
7:0	Header Type — RO. Hardwired to 00h.

14.1.10 NAMBAR—Native Audio Mixer Base Address Register (Audio—D31:F5)

Address Offset:	10–13h	Attribute:	R/W, RO
Default Value:	0000001h	Size:	32 bits
Lockable:	No	Power Well:	Core

The Native PCI Mode Audio function uses PCI Base Address register #1 to request a contiguous block of I/O space that is to be used for the Native Audio Mixer software interface. The mixer requires 256 bytes of I/O space. Native Audio Mixer and Modem codec I/O registers are located from 00h to 7Fh and reside in the codec. Access to these registers will be decoded by the AC '97 controller and forwarded over the AC-link to the codec. The codec will then respond with the register value.

In the case of the split codec implementation, accesses to the different codecs are differentiated by the controller by using address offsets 00h–7Fh for the primary codec and address offsets 80h–FEh for the secondary codec.

Note: The tertiary codec cannot be addressed via this address space. The tertiary space is only available from the new MMBAR register. This register powers up as read only and only becomes writeable when the IOSE bit in offset 41h is set.

For description of these I/O registers, refer to the *Audio Codec '97 Component Specification, Version 2.3*.

Bit	Description
31:16	Hardwired to 0s
15:8	Base Address — R/W. These bits are used in the I/O space decode of the Native Audio Mixer interface registers. The number of upper bits that a device actually implements depends on how much of the address space the device will respond to. For the AC '97 mixer, the upper 16 bits are hardwired to 0, while bits 15:8 are programmable. This configuration yields a maximum I/O block size of 256 bytes for this base address.
7:1	Reserved. Read as 0s.
0	Resource Type Indicator (RTE) — RO. Hardwired to 1, indicating a request for I/O space.

14.1.11 NABMBAR—Native Audio Bus Mastering Base Address Register (Audio—D31:F5)

Address Offset:	14–17h	Attribute:	R/W, RO
Default Value:	00000001h	Size:	32 bits
Lockable:	No	Power Well:	Core

The Native PCI Mode Audio function uses PCI Base Address register #1 to request a contiguous block of I/O space that is to be used for the Native Mode Audio software interface.

Note: The DMA registers for S/PDIF and Microphone In 2 cannot be addressed via this address space. These DMA functions are only available from the new MBBAR register. This register powers up as read only and only becomes write-able when the IOSE bit in offset 41h is set.

Bit	Description
31:16	Hardwired to 0s
15:6	Base Address — R/W. These bits are used in the I/O space decode of the Native Audio Bus Mastering interface registers. The number of upper bits that a device actually implements depends on how much of the address space the device will respond to. For AC '97 bus mastering, the upper 16 bits are hardwired to 0, while bits 15:6 are programmable. This configuration yields a maximum I/O block size of 64 bytes for this base address.
5:1	Reserved. Read as 0s.
0	Resource Type Indicator (RTE) — RO. This bit is set to 0, indicating a request for I/O space.

14.1.12 MMBAR—Mixer Base Address Register (Audio—D31:F5)

Address Offset:	18–1Bh	Attribute:	R/W, RO
Default Value:	00000000h	Size:	32 bits
Lockable:	No	Power Well:	Core

This BAR creates 512 bytes of memory space to signify the base address of the register space. The lower 256 bytes of this space map to the same registers as the 256-byte I/O space pointed to by NAMBAR. The lower 384 bytes are divided as follows:

- 128 bytes for the primary codec (offsets 00–7Fh)
- 128 bytes for the secondary codec (offsets 80–FFh)
- 128 bytes for the tertiary codec (offsets 100–17Fh).
- 128 bytes of reserved space (offsets 180–1FFh), returning all 0s.

Bit	Description
31:9	Base Address — R/W Lower 32-bits of the 512-byte memory offset to use for decoding the primary, secondary, and tertiary codec's mixer spaces.
8:3	Reserved. Read as 0s.
2:1	Type — RO. Indicates the base address exists in 32-bit address space
0	Resource Type Indicator (RTE) — RO. Hardwired to 0, indicating a request for memory space.

14.1.13 MBBAR—Bus Master Base Address Register (Audio—D31:F5)

Address Offset:	1C–1Fh	Attribute:	R/W, RO
Default Value:	00000000h	Size:	32 bits
Lockable:	No	Power Well:	Core

This BAR creates 256-bytes of memory space to signify the base address of the bus master memory space. The lower 64-bytes of the space pointed to by this register point to the same registers as the MBBAR.

Bit	Description
31:8	Base Address — R/W. I/O offset to use for decoding the PCM In, PCM Out, and Microphone 1 DMA engines.
7:3	Reserved. Read as 0s.
2:1	Type — RO. Indicates the base address exists in 32-bit address space
0	Resource Type Indicator (RTE) — RO. This bit is set to 0, indicating a request for memory space.

14.1.14 SVID—Subsystem Vendor ID Register (Audio—D31:F5)

Address Offset:	2D–2Ch	Attribute:	R/WO
Default Value:	0000h	Size:	16 bits
Lockable:	No	Power Well:	Core

The SVID register, in combination with the Subsystem ID register, enable the operating environment to distinguish one audio subsystem from the other(s). This register is implemented as write-once register. Once a value is written to it, the value can be read back. Any subsequent writes will have no effect.

This register is not affected by the D3_{HOT} to D0 transition.

Bit	Description
15:0	Subsystem Vendor ID — R/Write-Once.

14.1.15 SID—Subsystem ID Register (Audio—D31:F5)

Address Offset:	2E–2Fh	Attribute:	R/WO
Default Value:	0000h	Size:	16 bits
Lockable:	No	Power Well:	Core

The SID register, in combination with the Subsystem Vendor ID register make it possible for the operating environment to distinguish one audio subsystem from the other(s). This register is implemented as write-once register. Once a value is written to it, the value can be read back. Any subsequent writes will have no effect. This register is not affected by the D3_{HOT} to D0 transition.

Bit	Description
15:0	Subsystem ID — R/Write-Once.

14.1.16 CAP_PTR—Capabilities Pointer Register (Audio—D31:F5)

Address Offset:	34h	Attribute:	RO
Default Value:	50h	Size:	8 bits
Lockable:	No	Power Well:	Core

This register indicates the offset for the capability pointer.

Bit	Description
7:0	Capabilities Pointer (CAP_PTR) — RO. This field indicates that the first capability pointer offset is offset 50h

14.1.17 INTR_LN—Interrupt Line Register (Audio—D31:F5)

Address Offset:	3Ch	Attribute:	R/W
Default Value:	00h	Size:	8 bits
Lockable:	No	Power Well:	Core

This register indicates which PCI interrupt line is used for the AC '97 module interrupt.

Bit	Description
7:0	Interrupt Line (INT_LN) — R/W. This data is not used by the ICH4. It is used to communicate to software the interrupt line that the interrupt pin is connected to.

14.1.18 INTR_PN—Interrupt Pin Register (Audio—D31:F5)

Address Offset:	3Dh	Attribute:	RO
Default Value:	02h	Size:	8 bits
Lockable:	No	Power Well:	Core

This register indicates which PCI interrupt pin is used for the AC '97 module interrupt. The AC '97 interrupt is internally OR'd to the interrupt controller with the PIRQB# signal.

Bit	Description
7:3	Reserved.
2:0	Interrupt Pin (INT_PN) — RO. Hardwired to 010b to select PIRQB#.

14.1.19 PCID—Programmable Codec ID Register (Audio—D31:F5)

Address Offset:	40h	Attribute:	R/W
Default Value:	09h	Size:	8 bits
Lockable:	No	Power Well:	Core

This register is used to specify the ID for the secondary and tertiary codecs for I/O accesses. This register is not affected by the D3_{HOT} to D0 transition.

Note: The value in this register must only be modified prior to any AC '97 codec accesses.

Bit	Description
7:4	Reserved.
3:2	Tertiary Codec ID (TID) — R/W. These bits define the encoded ID that is used to address the tertiary codec I/O space. Bit 1 is the first bit sent and Bit 0 is the second bit sent on AC_SDATA_OUT during slot 0.
1:0	Secondary Codec ID (SCID) — R/W. These two bits define the encoded ID that is used to address the secondary codec I/O space. The two bits are the ID that will be placed on slot-0, bits 0 and 1, upon an I/O access to the secondary codec. Bit 1 is the first bit sent and bit 0 is the second bit sent on AC_SDATA_OUT during slot 0.

14.1.20 CFG—Configuration Register (Audio—D31:F5)

Address Offset:	41h	Attribute:	R/W
Default Value:	00h	Size:	8 bits
Lockable:	No	Power Well:	Core

This register is used to specify the ID for the secondary and tertiary codecs for I/O accesses. This register is not affected by the D3_{HOT} to D0 transition.

Bit	Description
7:1	Reserved — RO.
0	I/O Space Enable (IOSE) — R/W. 0 = Disable. The IOS bit at offset 04h and the I/O space BARs at offset 10h and 14h become read only registers. (Default) 1 = Enable. BIOS must explicitly set this bit to allow a legacy driver to work.

14.1.21 PID—PCI Power Management Capability ID Register (Audio—D31:F5)

Address Offset:	50h	Attribute:	RO
Default Value:	0001h	Size:	16 bits
Lockable:	No	Power Well:	Core

Bit	Description
15:8	Next Capability (NEXT) — RO. This field indicates that the next item in the list is at offset 00h.
7:0	Capability ID (CAP) — RO. This field indicates that this pointer is a message signaled interrupt capability.

14.1.22 PC—Power Management Capabilities Register (Audio—D31:F5)

Address Offset:	52h	Attribute:	RO
Default Value:	C9C2h	Size:	16 bits
Lockable:	No	Power Well:	Core

This register is not affected by the D3_{HOT} to D0 transition.

Bit	Description
15:11	PME Support — RO. This field indicates PME# can be generated from all D states.
10:9	Reserved.
8:6	Auxiliary Current — RO. This field reports 375 mA maximum Suspend well current required when in the D3 _{cold} state.
5	Device Specific Initialization (DSI) — RO. This bit indicates that no device-specific initialization is required.
4	Reserved — RO.
3	PME Clock — RO. This bit indicates that PCI clock is not required to generate PME#.
2:0	Version — RO. Indicates support for Revision 1.1 of the PCI Power Management Specification.

14.1.23 PCS—Power Management Control and Status Register (Audio—D31:F5)

Address Offset:	54h	Attribute:	R/W, R/WC
Default Value:	0000h	Size:	16 bits
Lockable:	No	Power Well:	Resume

Bit	Description
15	<p>PME Status (PMES) — R/W/C.</p> <p>0 = Software clears this bit by writing a 1 to it.</p> <p>1 = This bit is set when the AC '97 controller would normally assert the PME# signal independent of the state of the PME_En bit. This bit resides in the resume well.</p>
14:9	Reserved — RO.
8	<p>PME Enable (PMEE) — R/W.</p> <p>0 = Disable.</p> <p>1 = Enable. When set, and if corresponding PMES is also set, the AC'97 controller sets the AC97_STS bit in the GPE0_STS register</p>
7:2	Reserved — RO.
1:0	<p>Power State — R/W. This field is used both to determine the current power state of the AC '97 controller and to set a new power state. The values are:</p> <p>00 = D0 state</p> <p>01 = not supported</p> <p>10 = not supported</p> <p>11 = D3_{HOT} state</p> <p>When in the D3_{HOT} state, the AC '97 controller's configuration space is available, but the I/O and memory spaces are not. Additionally, interrupts are blocked.</p> <p>If software attempts to write a value of 10b or 01b in to this field, the write operation must complete normally; however, the data is discarded and no state change occurs.</p>

14.2 AC '97 Audio I/O Space (D31:F5)

The AC '97 I/O space includes Native Audio Bus Master Registers and Native Mixer Registers. For the ICH4, the offsets are important as they will determine bits[1:0] of the TAG field (codec ID).

Audio Mixer I/O space can be accessed as a 16-bit field only since the data packet length on AC-link is a word. Any S/W access to the codec will be done as a 16-bit access starting from the first active byte. In case no byte enables are active, the access will be done at the first word of the QWord that contains the address of this request.

Table 14-2. Intel® ICH4 Audio Mixer Register Configuration (Sheet 1 of 2)

Primary Offset (Codec ID =00)	Secondary Offset (Codec ID =01)	Tertiary Offset (Codec ID =10)	NAMBAR Exposed Registers (D31:F5)
00h	80h	100h	Reset
02h	82h	102h	Master Volume
04h	84h	104h	Aux Out Volume
06h	86h	106h	Mono Volume
08h	88h	108h	Master Tone (R & L)
0Ah	8Ah	10Ah	PC_BEEP Volume
0Ch	8Ch	10Ch	Phone Volume
0Eh	8Eh	10Eh	Mic Volume
10h	90h	110h	Line In Volume
12h	92h	112h	CD Volume
14h	94h	114h	Video Volume
16h	96h	116h	Aux In Volume
18h	98h	118h	PCM Out Volume
1Ah	9Ah	11Ah	Record Select
1Ch	9Ch	11Ch	Record Gain
1Eh	9Eh	11Eh	Record Gain Mic
20h	A0h	120h	General Purpose
22h	A2h	122h	3D Control
24h	A4h	124h	AC '97 RESERVED
26h	A6h	126h	Powerdown Ctrl/Stat
28h	A8h	128h	Extended Audio
2Ah	AAh	12Ah	Extended Audio Ctrl/Stat
2Ch	ACh	12Ch	PCM Front DAC Rate
2Eh	A Eh	12Eh	PCM Surround DAC Rate
30h	B0h	130h	PCM LFE DAC Rate
32h	B2h	132h	PCM LR ADC Rate
34h	B4h	134h	MIC ADC Rate
36h	B6h	136h	6Ch Vol: C, LFE

Table 14-2. Intel® ICH4 Audio Mixer Register Configuration (Sheet 2 of 2)

Primary Offset (Codec ID =00)	Secondary Offset (Codec ID =01)	Tertiary Offset (Codec ID =10)	NAMBAR Exposed Registers (D31:F5)
38h	B8h	138h	6Ch Vol: L, R Surround
3Ah	BAh	13Ah	S/PDIF Control
3C–56h	BC–D6h	13C–156h	Intel RESERVED
58h	D8h	158h	AC '97 Reserved
5Ah	DAh	15Ah	Vendor Reserved
7Ch	FCh	17Ch	Vendor ID1
7Eh	FEh	17Eh	Vendor ID2

NOTE:

1. Software should not try to access reserved registers
2. Primary Codec ID cannot be changed. Secondary codec ID can be changed via bits 1:0 of configuration register 40h. Tertiary codec ID can be changed via bits 3:2 of configuration register 40h.
3. The tertiary offset is only available through the memory space defined by the MMBAR register.

The Bus Master registers are located from offset + 00h to offset + 51h and reside in the AC '97 controller. Accesses to these registers do NOT cause the cycle to be forwarded over the AC-link to the codec. Software can access these registers as bytes, word, or DWord quantities, but reads must not cross DWord boundaries.

In the case of the split codec implementation accesses to the different codecs are differentiated by the controller by using address offsets 00h – 7Fh for the primary codec, address offsets 80h – FFh for the secondary codec and address offsets 100h – 17Fh for the tertiary codec.

The Global Control (GLOB_CNT) and Global Status (GLOB_STA) registers are aliased to the same global registers in the audio and modem I/O space. Therefore a read/write to these registers in either audio or modem I/O space affects the same physical register.

Bus Mastering registers exist in I/O space and reside in the AC '97 controller. The six channels, PCM in, PCM in 2, PCM out, Mic in, Mic 2, and S/PDIF out, each have their own set of Bus Mastering registers. The following register descriptions apply to all six channels. The register definition section titles use a generic “x_” in front of the register to indicate that the register applies to all six channels. The naming prefix convention used in Table 14-3 and in the register description I/O address is as follows:

PI = PCM in channel
 PO = PCM out channel
 MC = Mic in channel.
 MC2 = Mic 2 channel
 PI2 = PCM in 2 channel
 SP = S/PDIF out channel.

Table 14-3. Native Audio Bus Master Control Registers (Sheet 1 of 2)

Offset	Mnemonic	Name	Default	Access
00h	PI_BDBAR	PCM in Buffer Descriptor list Base Address	00000000h	R/W
04h	PI_CIV	PCM in Current Index Value	00h	RO
05h	PI_LVI	PCM in Last Valid Index	00h	R/W
06h	PI_SR	PCM in Status	0001h	R/WC, RO
08h	PI_PICB	PCM in Position in Current Buffer	0000h	RO
0Ah	PI_PIV	PCM in Prefetched Index Value	00h	RO
0Bh	PI_CR	PCM in Control	00h	R/W
10h	PO_BDBAR	PCM out Buffer Descriptor list Base Address	00000000h	R/W
14h	PO_CIV	PCM out Current Index Value	00h	RO
15h	PO_LVI	PCM out Last Valid Index	00h	R/W
16h	PO_SR	PCM out Status Register	0001h	R/W
18h	PO_PICB	PCM out Position In Current Buffer	0000h	RO
1Ah	PO_PIV	PCM out Prefetched Index Value	00h	RO
1Bh	PO_CR	PCM out Control Register	00h	R/W
20h	MC_BDBAR	Mic. in Buffer Descriptor List Base Address	00000000h	R/W
24h	MC_CIV	Mic. in Current Index Value	00h	RO
25h	MC_LVI	Mic. in Last Valid Index	00h	R/W
26h	MC_SR	Mic. In Status Register	0001h	R/W
28h	MC_PICB	Mic. In Position In Current Buffer	0000h	RO
2Ah	MC_PIV	Mic. in Prefetched Index Value	00h	RO
2Bh	MC_CR	Mic. in Control Register	00h	R/W
2Ch	GLOB_CNT	Global Control	00000000h	R/W
30h	GLOB_STA	Global Status	00700000h	RO, R/W, R/WC
34h	ACC_SEMA	Codec Write Semaphore Register	00h	R/W
40–43h	MC2_BDBAR	Mic. 2 Buffer Descriptor List Base Address	00h	RO
44h	MC2_CIV	Mic. 2 Current Index Value	00h	R/W
45h	MC2_LVI	Mic. 2 Last Valid Index	0001h	R/W
46–47h	MC2_SR	Mic. 2 Status Register	0000h	RO
48–49h	MC2_PICB	Mic 2 Position In Current Buffer	00h	RO
4Ah	MC2_PIV	Mic. 2 Prefetched Index Value	00h	R/W
4Bh	MC2_CR	Mic. 2 Control Register	00h	RO
50–53h	PI2_BDBAR	PCM in 2 Buffer Descriptor List Base Address	00000000h	R/W
54h	PI2_CIV	PCM in 2 Current Index Value	00h	RO
55h	PI2_LVI	PCM in 2 Last Valid Index	00h	R/W
56–57h	PI2_SR	PCM in 2 Status Register	0001h	R/W
58–59h	PI2_PICB	PCM in 2 Position in Current Buffer	0000h	RO

Table 14-3. Native Audio Bus Master Control Registers (Sheet 2 of 2)

Offset	Mnemonic	Name	Default	Access
5Ah	PI2_PIV	PCM In 2 Prefetched Index Value	00h	RO
5Bh	PI2_CR	PCM In 2 Control Register	00h	R/W
60–63	SP_BAR	S/PDIF Buffer Descriptor List Base Address	00000000h	R/W
64h	SP_CIV	S/PDIF Current Index Value	00h	RO
65h	SP_LVI	S/PDIF Last Valid Index	00h	R/W
66–67h	SP_SR	S/PDIF Status Register	0001h	R/W
68–69h	SP_PICB	S/PDIF Position In Current Buffer	0000h	RO
6Ah	SP_PIV	S/PDIF Prefetched Index Value	00h	RO
6Bh	SP_CR	S/PDIF Control Register	00h	R/W
80h	SDM	SData_IN Map	00h	R/W, RO

Note: Internal reset as a result of D3_{HOT} to D0 transition will reset all the core well registers except the registers shared with the AC '97 Modem (GCR, GSR, CASR). All resume well registers will not be reset by the D3_{HOT} to D0 transition.

Core Well registers and bits NOT reset by the D3_{HOT} to D0 transition:

- offset 2Ch–2Fh – bits[6:0] Global Control (GLOB_CNT)
- offset 30h–33h – bits[29,15,11:10,0] Global Status (GLOB_STA)
- offset 34h – Codec Access Semaphore Register (CAS)

Resume Well registers and bits will NOT be reset by the D3_{HOT} to D0 transition:

- offset 30h–33h – bits[17:16] Global Status (GLOB_STA)

14.2.1 x_BDBAR—Buffer Descriptor Base Address Register

I/O Address: NABMBAR + 00h (PIBDBAR), Attribute: R/W
 NABMBAR + 10h (POBDBAR),
 NABMBAR + 20h (MCBDBAR),
 MBBAR + 40h (MC2BDBAR),
 MBBAR + 50h (PI2BDBAR),
 MBBAR + 60h (SPBAR)

Default Value: 00000000h Size: 32 bits
 Lockable: No Power Well: Core

Software can read the register at offset 00h by performing a single 32 bit read from address offset 00h. Reads across DWord boundaries are not supported.

Bit	Description
31:3	Buffer Descriptor Base Address [31:3] — R/W. These bits represent address bits 31:3. The data should be aligned on 8 byte boundaries. Each buffer descriptor is 8 bytes long and the list can contain a maximum of 32 entries.
2:0	Hardwired to 0.

14.2.2 x_CIV—Current Index Value Register

I/O Address:	NABMBAR + 04h (PICIV), NABMBAR + 14h (POCIV), NABMBAR + 24h (MCCIV) MBBAR + 44h (MC2CIV) MBBAR + 54h (PI2CIV) MBBAR + 64h (SPCIV)	Attribute:	RO
Default Value:	00h	Size:	8 bits
Lockable:	No	Power Well:	Core

Software can read the registers at offsets 04h, 05h and 06h simultaneously by performing a single 32 bit read from address offset 04h. Software can also read this register individually by doing a single 8-bit read to offset 04h. Reads across DWord boundaries are not supported.

Bit	Description
7:5	Hardwired to 0
4:0	Current Index Value [4:0] — RO. These bits represent which buffer descriptor within the list of 32 descriptors is currently being processed. As each descriptor is processed, this value is incremented. The value rolls over after it reaches 31.

14.2.3 x_LVI—Last Valid Index Register

I/O Address:	NABMBAR + 05h (PILVI), NABMBAR + 15h (POLVI), NABMBAR + 25h (MCLVI) MBBAR + 45h (MC2LVI) MBBAR + 55h (PI2LVI) MBBAR + 65h (SPLVI)	Attribute:	R/W
Default Value:	00h	Size:	8 bits
Lockable:	No	Power Well:	Core

Software can read the registers at offsets 04h, 05h and 06h simultaneously by performing a single 32 bit read from address offset 04h. Software can also read this register individually by doing a single 8-bit read to offset 05h. Reads across DWord boundaries are not supported.

Bit	Description
7:5	Hardwired to 0.
4:0	Last Valid Index [4:0] — R/W. This field represents the last valid descriptor in the list. This value is updated by the software each time it prepares a new buffer and adds it to the list.

14.2.4 x_SR—Status Register

I/O Address:	NABMBAR + 06h (PISR), NABMBAR + 16h (POSR), NABMBAR + 26h (MCSR) MBBAR + 46h (MC2SR) MBBAR + 56h (PI2SR) MBBAR + 66h (SPSR)	Attribute:	R/WC, RO
Default Value:	0001h	Size:	16 bits
Lockable:	No	Power Well:	Core

Software can read the registers at offsets 04h, 05h, and 06h simultaneously by performing a single, 32-bit read from address offset 04h. Software can also read this register individually by doing a single, 16-bit read to offset 06h. Reads across DWord boundaries are not supported.

Bit	Description
15:5	Reserved.
4	<p>FIFO Error (FIFOE) — R/WC.</p> <p>0 = Software clears this bit by writing a 1 to this bit position. 1 = FIFO error occurs.</p> <ul style="list-style-type: none"> • PISR Register: FIFO error indicates a FIFO overrun. The FIFO pointers do not increment, the incoming data is not written into the FIFO, thus is lost. • POSR Register: FIFO error indicates a FIFO underrun. The sample transmitted in this case should be the last valid sample. <p>The ICH4 will set the FIFOE bit if the under-run or overrun occurs when there are more valid buffers to process.</p>
3	<p>Buffer Completion Interrupt Status (BCIS) — R/WC.</p> <p>0 = Software clears this bit by writing a 1 to this bit position. 1 = Set by the hardware after the last sample of a buffer has been processed, AND if the Interrupt on Completion (IOC) bit is set in the command byte of the buffer descriptor. It remains active until cleared by software.</p>
2	<p>Last Valid Buffer Completion Interrupt (LVBCI) — R/WC.</p> <p>0 = Software clears this bit by writing a 1 to this bit position. 1 = Last valid buffer has been processed. It remains active until cleared by software. This bit indicates the occurrence of the event signified by the last valid buffer being processed. Thus, this is an event status bit that can be cleared by software once this event has been recognized. This event will cause an interrupt if the enable bit in the Control Register is set. The interrupt is cleared when the software clears this bit.</p> <p>In the case of <i>Transmits</i> (PCM out, Modem out) this bit is set, after the last valid buffer has been fetched (not after transmitting it). While in the case of <i>Receives</i>, this bit is set after the data for the last buffer has been written to memory.</p>
1	<p>Current Equals Last Valid (CELV) — RO.</p> <p>0 = Cleared by hardware when controller exists state (i.e., until a new value is written to the LVI register.) 1 = Current Index is equal to the value in the Last Valid Index Register, and the buffer pointed to by the CIV has been processed (i.e., after the last valid buffer has been processed). This bit is very similar to bit 2, except this bit reflects the state rather than the event. This bit reflects the state of the controller, and remains set until the controller exits this state.</p>
0	<p>DMA Controller Halted (DCH) — RO.</p> <p>0 = Running. 1 = Halted. This could happen because of the Start/Stop bit being cleared and the DMA engines are idle, or it could happen once the controller has processed the last valid buffer.</p>

14.2.5 x_PICB—Position In Current Buffer Register

I/O Address:	NABMBAR + 08h (PIPICB), NABMBAR + 18h (POPICB), NABMBAR + 28h (MCPICB) MBBAR + 48h (MC2PICB) MBBAR + 58h (PI2PICB) MBBAR + 68h (SPPICB)	Attribute:	RO
Default Value:	0000h	Size:	16 bits
Lockable:	No	Power Well:	Core

Software can read the registers at the offsets 08h, 0Ah, and 0Bh by performing a 32-bit read from the address offset 08h. Software can also read this register individually by doing a single, 16-bit read to offset 08h. Reads across DWord boundaries are not supported.

Bit	Description
15:0	Position In Current Buffer [15:0] — RO. These bits represent the number of samples left to be processed in the current buffer. Once again, this means, the number of samples not yet read from memory (in the case of reads from memory) or not yet written to memory (in the case of writes to memory), irrespective of the number of samples that have been transmitted/received across AC-link.

14.2.6 x_PIV—Prefetched Index Value Register

I/O Address:	NABMBAR + 0Ah (PIPIV), NABMBAR + 1Ah (POPIV), NABMBAR + 2Ah (MCPIV) MBBAR + 4Ah (MC2PIV) MBBAR + 5Ah (PI2PIV) MBBAR + 6Ah (SPPIV)	Attribute:	RO
Default Value:	00h	Size:	8 bits
Lockable:	No	Power Well:	Core

Software can read the registers at the offsets 08h, 0Ah, and 0Bh by performing a 32-bit read from the address offset 08h. Software can also read this register individually by doing a single, 8-bit read to offset 0Ah. Reads across DWord boundaries are not supported.

Bit	Description
7:5	Hardwired to 0.
4:0	Prefetched Index Value [4:0] — RO. This field indicates which buffer descriptor in the list has been prefetched. The bits in this register are also modulo 32 and roll over after they reach 31.

14.2.7 x_CR—Control Register

I/O Address:	NABMBAR + 0Bh (PICR), NABMBAR + 1Bh (POCR), NABMBAR + 2Bh (MCCR) MBBAR + 4Bh (MC2CR) MBBAR + 5Bh (PI2CR) MBBAR + 6Bh (SPCR)	Attribute:	R/W
Default Value:	00h	Size:	8 bits
Lockable:	No	Power Well:	Core

Software can read the registers at the offsets 08h, 0Ah, and 0Bh by performing a 32-bit read from the address offset 08h. Software can also read this register individually by doing a single, 8-bit read to offset 0Bh. Reads across DWord boundaries are not supported.

Bit	Description
7:5	Reserved.
4	Interrupt On Completion Enable (IOCE) — R/W. This bit controls whether or not an interrupt occurs when a buffer completes with the IOC bit set in its descriptor. 0 = Disable. Interrupt will not occur. 1 = Enable.
3	FIFO Error Interrupt Enable (FEIE) — R/W. This bit controls whether the occurrence of a FIFO error will cause an interrupt or not. 0 = Disable. Bit 4 in the Status Register will be set, but the interrupt will not occur. 1 = Enable. Interrupt will occur.
2	Last Valid Buffer Interrupt Enable (LVBIE) — R/W. This bit controls whether the completion of the last valid buffer will cause an interrupt or not. 0 = Disable. Bit 2 in the Status register will still be set, but the interrupt will not occur. 1 = Enable.
1	Reset Registers (RR) — R/W-Special. 0 = Removes reset condition. 1 = Contents of all Bus master related registers to be reset, except the interrupt enable bits (bit 4,3,2 of this register). Software needs to set this bit but need not clear it since the bit is self clearing. This bit must be set only when the Run/Pause bit is cleared. Setting it when the Run bit is set will cause undefined consequences.
0	Run/Pause Bus Master (RPBM) — R/W. 0 = Pause bus master operation. This results in all state information being retained (i.e., master mode operation can be stopped and then resumed). 1 = Run. Bus master operation starts.

14.2.8 GLOB_CNT—Global Control Register

I/O Address:	NABMBAR + 2Ch	Attribute:	R/W
Default Value:	00000000h	Size:	32 bits
Lockable:	No	Power Well:	Core

Reads across DWord boundaries are not supported.

Bit	Description
31:30	S/PDIF Slot Map (SSM) — R/W. If the run/pause bus master bit (bit 0 of offset 2Bh) is set, then the value in these bits indicate which slots S/PDIF data is transmitted on. Software must ensure that the programming here does not conflict with the PCM channels being used. If there is a conflict, unpredictable behavior will result - the hardware will not check for a conflict. 00 = Reserved 01 = Slots 7 and 8 10 = Slots 6 and 9 11 = Slots 10 and 11
29:24	Reserved.
23:22	PCM Out Mode (POM) — R/W. This field enables the PCM out channel to use 16 or 20-bit audio on PCM out. This does not affect the microphone of S/PDIF DMA. When greater than 16-bit audio is used, the data structures are aligned as 32-bits per sample, with the highest order bits representing the data, and the lower order bits as don't care. 00 = 16-bit audio (default) 01 = 20-bit audio 10 = Reserved. If set, indeterminate behavior will result. 11 = Reserved. If set, indeterminate behavior will result.
21:20	PCM 4/6 Enable — R/W. This field configures PCM Output for 2, 4 or 6 channel mode. 00 = 2-channel mode (default) 01 = 4-channel mode 10 = 6-channel mode 11 = Reserved
19:7	Reserved.
6	AC_SDIN2 Interrupt Enable (S2RE) — R/W. 0 = Disable. 1 = Enable an interrupt to occur when the codec on AC_SDIN[2] causes a resume event on the AC-link.
5	AC_SDIN1 Resume Interrupt Enable (S1RE) — R/W. 0 = Disable. 1 = Enable an interrupt to occur when the codec on AC_SDIN[1] causes a resume event on the AC-link.
4	AC_SDIN0 Resume Interrupt Enable (S0RE) — R/W. 0 = Disable. 1 = Enable an interrupt to occur when the codec on AC_SDIN[0] causes a resume event on the AC-link.
3	ACLINK Shut Off (LSO) — R/W. 0 = Normal operation. 1 = Controller disables all outputs which will be pulled low by internal pull down resistors.

Bit	Description
2	<p>AC '97 Warm Reset — R/W-Special.</p> <p>0 = Normal operation.</p> <p>1 = Writing a 1 to this bit causes a warm reset to occur on the AC-link. The warm reset will awaken a suspended codec without clearing its internal registers. If software attempts to perform a warm reset while bit_clk is running, the write will be ignored and the bit will not change. This bit is self-clearing (it remains set until the reset completes and bit_clk is seen on the ACLink, after which it clears itself).</p>
1	<p>AC '97 Cold Reset# — R/W.</p> <p>0 = Writing a 0 to this bit causes a cold reset to occur throughout the AC '97 circuitry. All data in the controller and the codec will be lost. Software needs to clear this bit no sooner than the minimum number of ms have elapsed.</p> <p>1 = This bit defaults to 0 and hence after reset, the driver needs to set this bit to a 1. The value of this bit is retained after suspends; hence, if this bit is set to a 1 prior to suspending, a cold reset is not generated automatically upon resuming.</p> <p>NOTE: This bit is in the Core well.</p>
0	<p>GPI Interrupt Enable (GIE) — R/W. This bit controls whether the change in status of any GPI causes an interrupt.</p> <p>0 = Bit 0 of the Global Status Register is set, but no interrupt is generated.</p> <p>1 = The change on value of a GPI causes an interrupt and sets bit 0 of the Global Status Register.</p>

14.2.9 GLOB_STA—Global Status Register

I/O Address:	NABMBAR + 30h	Attribute:	RO, R/W, R/WC
Default Value:	00700000h	Size:	32 bits
Lockable:	No	Power Well:	Core

Reads across DWord boundaries are not supported.

Bit	Description
31:30	Reserved.
29	<p>AC_SDIN2 Resume Interrupt (S2RI) — R/WC. This bit indicates that a resume event occurred on AC_SDIN[2]. This bit is not affected by D3_{HOT} to D0 Reset.</p> <p>0 = Cleared by writing a 1 to this bit position.</p> <p>1 = Resume event occurred.</p>
28	<p>AC_SDIN2 Codec Ready (S2CR) — RO. This bit reflects the state of the codec ready bit in AC_SDIN[2]. Bus masters ignore the condition of the codec ready bits, so software must check this bit before starting the bus masters. Once the codec is “ready”, it must never go “not ready” spontaneously.</p> <p>0 = Not Ready.</p> <p>1 = Ready.</p>
27	<p>Bit Clock Stopped (BCS) — RO. This bit indicates that the bit clock is not running.</p> <p>0 = Transition is found on BIT_CLK.</p> <p>1 = ICH4 detects that there has been no transition on BIT_CLK for four consecutive PCI clocks.</p>
26	<p>S/PDIF Interrupt (SPINT) — RO.</p> <p>0 = When the specific status bit is cleared, this bit will be cleared.</p> <p>1 = Indicates that the S/PDIF out channel interrupt status bits have been set.</p>

Bit	Description
25	PCM In 2 Interrupt (P2INT) — RO. 0 = When the specific status bit is cleared, this bit will be cleared. 1 = Indicates that one of the PCM In 2 channel status bits have been set.
24	Microphone 2 In Interrupt (M2INT) — RO. 0 = When the specific status bit is cleared, this bit will be cleared. 1 = Indicates that one of the Mic in channel interrupts status bits has been set.
23:22	Sample Capabilities — RO. Indicates the capability to support more greater than 16-bit audio. 00 = Reserved 01 = 16 and 20-bit Audio supported (ICH4 value) 10 = Reserved 11 = Reserved
21:20	Multichannel Capabilities — RO. Indicates the capability to support more 4 and 6 channels on PCM Out.
19:18	Reserved.
17	MD3 — R/W. This bit is a power down semaphore for Modem. The bit exists in the suspend well and maintains context across power states (except G3). The bit has no hardware function. It is used by software in conjunction with the AD3 bit to coordinate the entry of the two codecs into D3 state. This bit is not affected by D3 _{HOT} to D0 Reset.
16	AD3 — R/W. This bit is a power down semaphore for Audio. The bit exists in the suspend well and maintains context across power states (except G3). The bit has no hardware function. It is used by software in conjunction with the MD3 bit to coordinate the entry of the two codecs into D3 state. This bit is not affected by D3 _{HOT} to D0 Reset.
15	Read Completion Status (RCS) — R/WC. This bit indicates the status of codec read completions. 0 = A codec read completes normally. 1 = A codec read results in a time-out. The bit remains set until being cleared by software writing a 1 to the bit location. This bit is not affected by D3 _{HOT} to D0 Reset.
14	Bit 3 of slot 12 — RO. Display bit 3 of the most recent slot 12.
13	Bit 2 of slot 12 — RO. Display bit 2 of the most recent slot 12.
12	Bit 1 of slot 12 — RO. Display bit 1 of the most recent slot 12.
11	AC_SDIN1 Resume Interrupt (S1RI) — R/WC. This bit indicates that a resume event occurred on AC_SDIN[1]. 0 = Cleared by writing a 1 to this bit position. 1 = Resume event occurred. This bit is not affected by D3 _{HOT} to D0 Reset.
10	AC_SDIN0 Resume Interrupt (S0RI) — R/WC. This bit indicates that a resume event occurred on AC_SDIN[0]. 0 = Cleared by writing a 1 to this bit position. 1 = Resume event occurred. This bit is not affected by D3 _{HOT} to D0 Reset.
9	AC_SDIN1 Codec Ready (S1CR) — RO. This bit reflects the state of the codec ready bit in AC_SDIN[1]. Bus masters ignore the condition of the codec ready bits, so software must check this bit before starting the bus masters. Once the codec is "ready", it must never go "not ready" spontaneously. 0 = Not Ready. 1 = Ready.

Bit	Description
8	AC_SDIN0 Codec Ready (SOCR) — RO. This bit reflects the state of the codec ready bit in AC_SDIN [0]. Bus masters ignore the condition of the codec ready bits, so software must check this bit before starting the bus masters. Once the codec is “ready”, it must never go “not ready” spontaneously. 0 = Not Ready. 1 = Ready.
7	Mic In Interrupt (MINT) — RO. 0 = When the specific status bit is cleared, this bit will be cleared. 1 = This bit indicates that one of the Mic in channel interrupts status bits has been set.
6	PCM Out Interrupt (POINT) — RO. 0 = When the specific status bit is cleared, this bit will be cleared. 1 = This bit indicates that one of the PCM out channel interrupts status bits has been set.
5	PCM In Interrupt (PIINT) — RO. 0 = When the specific status bit is cleared, this bit will be cleared. 1 = This bit indicates that one of the PCM in channel interrupts status bits has been set.
4:3	Reserved
2	Modem Out Interrupt (MOINT) — RO. 0 = When the specific status bit is cleared, this bit will be cleared. 1 = This bit indicates that one of the modem out channel interrupts status bits has been set.
1	Modem In Interrupt (MIINT) — RO. 0 = When the specific status bit is cleared, this bit will be cleared. 1 = This bit indicates that one of the modem in channel interrupts status bits has been set.
0	GPI Status Change Interrupt (GSCI) — R/WC. 0 = The bit is cleared by software writing a 1 to this bit location. 1 = This bit reflects the state of bit 0 in slot 12, and is set when bit 0 of slot 12 is set. This indicates that one of the GPIs changed state, and that the new values are available in slot 12. This bit is not affected by D3 _{HOT} to D0 Reset.

14.2.10 CAS—Codec Access Semaphore Register

I/O Address:	NABMBAR + 34h	Attribute:	R/W
Default Value:	00h	Size:	8 bits
Lockable:	No	Power Well:	Core

Reads across DWord boundaries are not supported.

Bit	Description
7:1	Reserved.
0	Codec Access Semaphore (CAS) — R/W-Special. This bit is read by software to check whether a codec access is currently in progress. 0 = No access in progress. 1 = The act of reading this register sets this bit to 1. The driver that read this bit can then perform an I/O access. Once the access is completed, hardware automatically clears this bit.

14.2.11 SDM—SDATA_IN Map Register

I/O Address:	NABMBAR + 80h	Attribute:	R/W, RO
Default Value:	00h	Size:	8 bits
Lockable:	No	Power Well:	Core

Reads across DWord boundaries are not supported.

Bit	Description
7:6	PCM In 2, Microphone In 2 Data In Line (DI2L) — R/W. When the SE bit is set, these bits indicate which AC_SDIN line should be used by the hardware for decoding the input slots for PCM In 2 and Microphone In 2. When the SE bit is cleared, the value of these bits are irrelevant, and PCM In 2 and Mic In 2 DMA engines are not available. 00 = AC_SDIN0 01 = AC_SDIN1 10 = AC_SDIN2 11 = Reserved
5:4	PCM In 1, Microphone In 1 Data In Line (DI1L) — R/W. When the SE bit is set, these bits indicate which AC_SDIN line should be used by the hardware for decoding the input slots for PCM In 1 and Microphone In 1. When the SE bit is cleared, the value of these bits are irrelevant, and the PCM In 1 and Mic In 1 engines use the OR'd AC_SDIN lines. 00 = AC_SDIN0 01 = AC_SDIN1 10 = AC_SDIN2 11 = Reserved
3	Steer Enable (SE) — R/W. When set, the AC_SDIN lines are treated separately and not OR'd together before being sent to the DMA engines. When cleared, the AC_SDIN lines are OR'd together, and the "Microphone In 2" and "PCM In 2" DMA engines are not available.
2	Reserved — RO.
1:0	Last Codec Read Data Input (LDI) — RO. When a codec register is read, this indicates which AC_SDIN the read data returned on. Software can use this to determine how the codecs are mapped. The values are: 00 = AC_SDIN0 01 = AC_SDIN1 10 = AC_SDIN2 11 = Reserved



This page is intentionally left blank.

AC '97 Modem Controller Registers (D31:F6)

15

15.1 AC '97 Modem PCI Configuration Space (D31:F6)

Register address locations not shown in Table 15-1 should be treated as Reserved.

Table 15-1. AC '97 Modem Controller PCI Configuration Register Address Map (Modem—D31:F6)

Offset	Mnemonic	Register	Default	Access
00–01h	VID	Vendor Identification	8086	RO
02–03h	DID	Device Identification	24C6h	RO
04–05h	PCICMD	PCI Command	0000	R/W, RO
06–07h	PCISTA	PCI Device Status	0290h	R/WC, RO
08h	RID	Revision Identification	See Note	RO
09h	PI	Programming Interface	00	RO
0Ah	SCC	Sub Class Code	03h	RO
0Bh	BCC	Base Class Code	07h	RO
0Eh	HEDT	Header Type	00	RO
10–13h	MMBAR	Modem Mixer Base Address	00000001h	R/W, RO
14–17h	MBAR	Modem Base Address	00000001h	R/W, RO
2C–2Dh	SVID	Subsystem Vendor ID	0000h	R/WO
2E–2Fh	SID	Subsystem ID	0000h	R/WO
34h	CAP_PTR	Capabilities Pointer	50h	RO
3Ch	INTR_LN	Interrupt Line	00h	RO
3Dh	INT_PN	Interrupt Pin	02h	RO
50–51h	PID	PCI Power Management ID	0001h	RO
52–53h	PC	Power Management Capabilities	C9C2h	RO
54–55h	PCS	Power Management Control and Status	0000h	R/WC, R/W

NOTE: Refer to the ICH4 Specification Update for the value of the Revision ID Register.

Note: Internal reset as a result of D3_{HOT} to D0 transition will reset all the core well registers except the following BIOS programmed registers as BIOS may not be invoked following the D3-to-D0 transition. All resume well registers will not be reset by the D3_{HOT} to D0 transition.

Core Well registers NOT reset by the D3_{HOT} to D0 transition:

- offset 2Ch–2Dh; Subsystem Vendor ID (SVID)
- offset 2Eh–2Fh; Subsystem ID (SID)

Resume Well registers will **not** be reset by the D3_{HOT} to D0 transition:

- offset 54h–55h; Power Management Control and Status (PCS)

15.1.1 VID—Vendor Identification Register (Modem—D31:F6)

Address Offset:	00–01h	Attribute:	RO
Default Value:	8086	Size:	16 Bits
Lockable:	No	Power Well:	Core

Bit	Description
15:0	Vendor Identification Value — RO.

15.1.2 DID—Device Identification Register (Modem—D31:F6)

Address Offset:	02–03h	Attribute:	RO
Default Value:	24C6h	Size:	16 Bits
Lockable:	No	Power Well:	Core

Bit	Description
15:0	Device Identification Value — RO.

15.1.3 PCICMD—PCI Command Register (Modem—D31:F6)

Address Offset:	04–05h	Attribute:	R/W, RO
Default Value:	0000h	Size:	16 bits
Lockable:	No	Power Well:	Core

PCICMD is a 16-bit control register. Refer to the PCI 2.2 specification for complete details on each bit.

Bit	Description
15:10	Reserved. Read 0.
9	Fast Back to Back Enable (FBE) — RO. Not implemented. Hardwired to 0.
8	SERR# Enable (SEN) — RO. Not implemented. Hardwired to 0.
7	Wait Cycle Control (WCC) — RO. Not implemented. Hardwired to 0.
6	Parity Error Response (PER) — RO. Not implemented. Hardwired to 0.
5	VGA Palette Snoop (VPS) — RO. Not implemented. Hardwired to 0.
4	Memory Write and Invalidate Enable (MWIE) — RO. Not implemented. Hardwired to 0.
3	Special Cycle Enable (SCE) — RO. Not implemented. Hardwired to 0.
2	Bus Master Enable (BME) — R/W. Controls standard PCI bus mastering capabilities. 0 = Disable 1 = Enable
1	Memory Space Enable (MSE) — RO. Hardwired to 0; AC '97 does not respond to memory accesses.
0	I/O Space Enable (IOSE) —R /W. This bit controls access to the I/O space registers. 0 = Disable access. (default = 0). 1 = Enable access to I/O space. The Native PCI Mode Base Address register should be programmed prior to setting this bit.

15.1.4 PCISTA—Device Status Register (Modem—D31:F6)

Address Offset:	06–07h	Attribute:	R/WC, RO
Default Value:	0290h	Size:	16 bits
Lockable:	No	Power Well:	Core

PCISTA is a 16-bit status register. Refer to the PCI 2.2 specification for complete details on each bit.

Bit	Description
15	Detected Parity Error (DPE) — RO. Not implemented. Hardwired to 0.
14	Signaled System Error (SSE) — RO. Not implemented. Hardwired to 0.
13	Master Abort Status (MAS) — R/WC. 0 = Software clears this bit by writing a 1 to the bit position. 1 = Bus Master AC '97 interface function, as a master, generates a master abort.
12	Reserved. Read as 0.
11	Signaled Target Abort (STA) — RO. Not implemented. Hardwired to 0.
10:9	DEVSEL# Timing Status (DEV_STS) — RO. This 2-bit field reflects the ICH4's DEVSEL# timing parameter. These read only bits indicate the ICH4's DEVSEL# timing when performing a positive decode.
8	Data Parity Error Detected (DPED) — RO. Not implemented. Hardwired to 0.
7	Fast Back to Back Capable (FB2BC) — RO. Hardwired to 1. This bit indicates that the ICH4 as a target is capable of fast back-to-back transactions.
6	User Definable Features (UDF) — RO. Not implemented. Hardwired to 0.
5	66 MHz Capable (66MHZ_CAP) — RO. Hardwired to 0.
4	Capabilities List (CAP_LIST) — RO. This field indicates that the controller contains a capabilities pointer list. The first item is pointed to by looking at configuration offset 34h.
3:0	Reserved

15.1.5 RID—Revision Identification Register (Modem—D31:F6)

Address Offset:	08h	Attribute:	RO
Default Value:	See Bit Description	Size:	8 Bits
Lockable:	No	Power Well:	Core

Bit	Description
7:0	Revision Identification Value — RO. Refer to the ICH4 Specification Update for the value of the Revision ID Register.

15.1.6 PI—Programming Interface Register (Modem—D31:F6)

Address Offset:	09h	Attribute:	RO
Default Value:	00h	Size:	8 bits
Lockable:	No	Power Well:	Core

Bit	Description
7:0	Programming Interface — RO.

15.1.7 SCC—Sub Class Code Register (Modem—D31:F6)

Address Offset:	0Ah	Attribute:	RO
Default Value:	03h	Size:	8 bits
Lockable:	No	Power Well:	Core

Bit	Description
7:0	Sub Class Code — RO. 03h = Generic Modem.

15.1.8 BCC—Base Class Code Register (Modem—D31:F6)

Address Offset:	0Bh	Attribute:	RO
Default Value:	07h	Size:	8 bits
Lockable:	No	Power Well:	Core

Bit	Description
7:0	Base Class Code — RO. 07h = Simple Communications controller.

15.1.9 HEDT—Header Type Register (Modem—D31:F6)

Address Offset:	0Eh	Attribute:	RO
Default Value:	00h	Size:	8 bits
Lockable:	No	Power Well:	Core

Bit	Description
7:0	Header Type — RO.

15.1.10 MMBAR—Modem Mixer Base Address Register (Modem—D31:F6)

Address Offset: 10–13h Attribute: R/W, RO
 Default Value: 00000001h Size: 32 bits

The Native PCI Mode Modem uses PCI Base Address register #1 to request a contiguous block of I/O space that is to be used for the Modem Mixer software interface. The mixer requires 256 bytes of I/O space. All accesses to the mixer registers are forwarded over the AC-link to the codec where the registers reside.

In the case of the split codec implementation accesses to the different codecs are differentiated by the controller by using address offsets 00h – 7Fh for the primary codec and address offsets 80h – FEh for the secondary codec.

Bit	Description
31:16	Hardwired to 0s
15:8	Base Address — R/W. These bits are used in the I/O space decode of the Modem interface registers. The number of upper bits that a device actually implements depends on how much of the address space the device will respond to. For the AC '97 Modem, the upper 16 bits are hardwired to 0, while bits 15:8 are programmable. This configuration yields a maximum I/O block size of 256 bytes for this base address.
7:1	Reserved. Read as 0s
0	Resource Type Indicator (RTE) — RO. This bit is set to 1, indicating a request for I/O space.

15.1.11 MBAR—Modem Base Address Register (Modem—D31:F6)

Address Offset: 14–17h Attribute: R/W, RO
 Default Value: 00000001h Size: 32 bits

The Modem function uses PCI Base Address register #1 to request a contiguous block of I/O space that is to be used for the Modem software interface. The Modem Bus Mastering register space requires 128 bytes of I/O space. All Modem registers reside in the controller, therefore cycles are **not** forwarded over the AC-link to the codec.

Bit	Description
31:16	Hardwired to 0s
15:7	Base Address — R/W. These bits are used in the I/O space decode of the Modem interface registers. The number of upper bits that a device actually implements depends on how much of the address space the device will respond to. For the AC '97 Modem, the upper 16 bits are hardwired to 0, while bits 15:7 are programmable. This configuration yields a maximum I/O block size of 128 bytes for this base address.
6:1	Reserved. Read as 0s
0	Resource Type Indicator (RTE) — RO. This bit is set to 1, indicating a request for I/O space.

15.1.12 SVID—Subsystem Vendor ID (Modem—D31:F6)

Address Offset:	2C–2Dh	Attribute:	R/WO
Default Value:	0000h	Size:	16 bits
Lockable:	No	Power Well:	Core

The SVID register, in combination with the Subsystem ID register, enable the operating environment to distinguish one audio subsystem from the other(s). This register is implemented as a write-once register. Once a value is written to it, the value can be read back. Any subsequent writes will have no effect. This register is not affected by the D3_{HOT} to D0 transition.

Bit	Description
15:0	Subsystem Vendor ID — R/Write-Once.

15.1.13 SID—Subsystem ID (Modem—D31:F6)

Address Offset:	2E–2Fh	Attribute:	R/WO
Default Value:	0000h	Size:	16 bits
Lockable:	No	Power Well:	Core

The SID register, in combination with the Subsystem Vendor ID register make it possible for the operating environment to distinguish one audio subsystem from another. This register is implemented as write-once register. Once a value is written to it, the value can be read back. Any subsequent writes will have no effect.

This register is not affected by the D3_{HOT} to D0 transition.

Bit	Description
15:0	Subsystem ID — R/Write-Once.

15.1.14 CAP_PTR—Capabilities Pointer (Modem—D31:F6)

Address Offset:	34h	Attribute:	RO
Default Value:	50h	Size:	8 bits
Lockable:	No	Power Well:	Core

This register indicates the offset for the capability pointer.

Bit	Description
7:0	Capabilities Pointer (CAP_PTR) — RO. This field indicates that the first capability pointer offset is offset 50h.

15.1.15 INTR_LN—Interrupt Line Register (Modem—D31:F6)

Address Offset:	3Ch	Attribute:	R/W
Default Value:	00h	Size:	8 bits
Lockable:	No	Power Well:	Core

This register indicates which PCI interrupt line is used for the AC '97 module interrupt.

Bit	Description
7:0	Interrupt Line (INTR_LN) — R/W. This data is not used by the ICH4. It is used to communicate to software the interrupt line that the interrupt pin is connected to.

15.1.16 INT_PIN—Interrupt Pin (Modem—D31:F6)

Address Offset:	3Dh	Attribute:	RO
Default Value:	02h	Size:	8 bits
Lockable:	No	Power Well:	Core

This register indicates which PCI interrupt pin is used for the AC '97 modem interrupt. The AC '97 interrupt is internally OR'd to the interrupt controller with the PIRQB# signal.

Bit	Description
7:3	Reserved
2:0	Interrupt Pin (INT_PIN) — RO. Hardwired to 010b to select PIRQB#.

15.1.17 PID—PCI Power Management Capability ID Register (Modem—D31:F6)

Address Offset:	50h	Attribute:	RO
Default Value:	0001h	Size:	16 bits
Lockable:	No	Power Well:	Core

Bit	Description
15:8	Next Capability (NEXT) — RO. This field indicates that this is the last item in the list.
7:0	Capability ID (CAP) — RO. This field indicates that this pointer is a message signaled interrupt capability.

15.1.18 PC—Power Management Capabilities Register (Modem—D31:F6)

Address Offset:	52h	Attribute:	RO
Default Value:	C9C2h	Size:	16 bits
Lockable:	No	Power Well:	Core

Bit	Description
15:11	PME Support — RO. This field indicates PME# can be generated from all D states.
10:9	Reserved.
8:6	Auxiliary Current — RO. This field reports 375 mA maximum Suspend well current required when in the D3cold state.
5	Device Specific Initialization (DSI) — RO. This bit indicates that no device-specific initialization is required.
4	Reserved — RO.
3	PME Clock — RO. This bit indicates that PCI clock is not required to generate PME#.
2:0	Version — RO. This field indicates support for Revision 1.1 of the PCI Power Management Specification.

15.1.19 PCS—Power Management Control and Status Register (Modem—D31:F6)

Address Offset:	54h	Attribute:	R/W, R/WC
Default Value:	0000h	Size:	16 bits
Lockable:	No	Power Well:	Resume

This register is not affected by the D3_{HOT} to D0 transition.

Bit	Description
15	<p>PME Status (PMES) — RW/C.</p> <p>0 = Software clears this bit by writing a 1 to the bit position.</p> <p>1 = This bit is set when the AC '97 controller would normally assert the PME# signal independent of the state of the PME_En bit. This bit resides in the resume well.</p>
14:9	Reserved — RO.
8	<p>PME Enable (PMEE) — R/W. When set, and if corresponding PMES is also set, the AC'97 controller sets the AC97_STS bit in the GPE0_STS register</p>
7:2	Reserved — RO.
1:0	<p>Power State — R/W. This field is used both to determine the current power state of the AC '97 controller and to set a new power state. The values are:</p> <p>00 = D0 state</p> <p>01 = not supported</p> <p>10 = not supported</p> <p>11 = D3_{HOT} state</p> <p>When in the D3_{HOT} state, the AC '97 controller's configuration space is available, but the I/O and memory spaces are not. Additionally, interrupts are blocked.</p> <p>If software attempts to write a value of 10b or 01b in to this field, the write operation must complete normally; however, the data is discarded and no state change occurs.</p>

15.2 AC '97 Modem I/O Space (D31:F6)

In the case of the split codec implementation, accesses to the modem mixer registers in different codecs are differentiated by the controller by using address offsets 00h – 7Fh for the primary codec and address offsets 80h – FEh for the secondary codec. Table 15-2 shows the register addresses for the modem mixer registers.

Table 15-2. Intel® ICH4 Modem Mixer Register Configuration

Register		MMBAR Exposed Registers (D31:F6)
Pri.	Sec.	
00h:38h	80h:B8h	Intel RESERVED
3Ch	BCh	Extended Modem ID
3Eh	BEh	Extended Modem Stat/Ctrl
40h	C0h	Line 1 DAC/ADC Rate
<i>42h</i>	<i>C2h</i>	<i>Line 2 DAC/ADC Rate</i>
<i>44h</i>	<i>C4h</i>	<i>Handset DAC/ADC Rate</i>
46h	C6h	Line 1 DAC/ADC Level Mute
<i>48h</i>	<i>C8h</i>	<i>Line 2 DAC/ADC Level Mute</i>
<i>4Ah</i>	<i>CAh</i>	<i>Handset DAC/ADC Level Mute</i>
4Ch	CCh	GPIO Pin Config
4Eh	CEh	GPIO Polarity/Type
50h	D0h	GPIO Pin Sticky
52h	D2h	GPIO Pin Wake Up
54h	D4h	GPIO Pin Status
56h	D6h	Misc. Modem AFE Stat/Ctrl
58h	D8h	AC '97 Reserved
5Ah	DAh	Vendor Reserved
7Ch	FCh	Vendor ID1
7Eh	FEh	Vendor ID2

NOTES:

1. Registers in italics are for functions not supported by the ICH4.
2. Software should not try to access reserved registers.
3. The ICH4 supports a modem codec connected to AC_SDIN[2:0], as long as the Codec ID is 00 or 01. However, the ICH4 does not support more than one modem codec. For a complete list of topologies, see the appropriate chipset Platform Design Guide.

The Global Control (GLOB_CNT) and Global Status (GLOB_STA) registers are aliased to the same global registers in the audio and modem I/O space. Therefore, a read/write to these registers in either audio or modem I/O space affects the same physical register. S/W could access these registers as bytes, word, or DWord quantities, but reads must not cross DWord boundaries.

These registers exist in I/O space and reside in the AC '97 controller. The two channels, Modem in and Modem out, each have their own set of Bus Mastering registers. The following register descriptions apply to both channels. The naming prefix convention used is as follows:

MI = Modem in channel
 MO = Modem out channel

Table 15-3. Modem Registers

Offset	Mnemonic	Name	Default	Access
00h	MI_BDBAR	Modem In Buffer Descriptor List Base Address Register	00000000h	R/W
04h	MI_CIV	Modem In Current Index Value Register	00h	RO
05h	MI_LVI	Modem In Last Valid Index Register	00h	R/W
06h	MI_SR	Modem In Status Register	0001h	R/WC, RO
08h	MI_PICB	Modem In Position In Current Buffer Register	00h	RO
0Ah	MI_PIV	Modem In Prefetch Index Value Register	00h	RO
0Bh	MI_CR	Modem In Control Register	00h	R/W
10h	MO_BDBAR	Modem Out Buffer Descriptor List Base Address Register	00000000h	R/W
14h	MO_CIV	Modem Out Current Index Value Register	00h	RO
15h	MO_LVI	Modem Out Last Valid Register	00h	R/W
16h	MO_SR	Modem Out Status Register	0001h	R/W
18h	MI_PICB	Modem In Position In Current Buffer Register	00h	RO
1Ah	MO_PIV	Modem Out Prefetched Index Register	00h	RO
1Bh	MO_CR	Modem Out Control Register	00h	R/W
3Ch	GLOB_CNT	Global Control	00000000h	R/W
40h	GLOB_STA	Global Status	00000000h	RO, R/WC, R/W
44h	ACC_SEMA	Codec Write Semaphore Register	00h	R/W

NOTE:

1. MI = Modem in channel; MO = Modem out channel

Note: Internal reset as a result of D3_{HOT} to D0 transition will reset all the core well registers except the registers shared with the AC '97 Audio controller (GCR, GSR, CASR). All resume well registers will not be reset by the D3_{HOT} to D0 transition.

Core Well registers and bits NOT reset by the D3_{HOT} to D0 transition:

- offset 3Ch–3Fh – bits[6:0] Global Control (GLOB_CNT)
- offset 40h–43h – bits[29,15,11:10] Global Status (GLOB_STA)
- offset 44h – Codec Access Semaphore Register (CAS)

Resume Well registers and bits will NOT be reset by the D3_{HOT} to D0 transition:

- offset 40h–43h – bits[17:16] Global Status (GLOB_STA)

15.2.1 x_BDBAR—Buffer Descriptor List Base Address Register

I/O Address:	MBAR + 00h (MIBDBAR), MBAR + 10h (MOBDBAR)	Attribute:	R/W
Default Value:	00000000h	Size:	32 bits
Lockable:	No	Power Well:	Core

Software can read the register at offset 00h by performing a single 32-bit read from address offset 00h. Reads across DWord boundaries are not supported.

Bit	Description
31:3	Buffer Descriptor List Base Address [31:3] — R/W. These bits represent address bits 31:3. The entries should be aligned on 8-byte boundaries.
2:0	Hardwired to 0.

15.2.2 x_CIV—Current Index Value Register

I/O Address:	MBAR + 04h (MICIV), MBAR + 14h (MOCIV),	Attribute:	RO
Default Value:	00h	Size:	8 bits
Lockable:	No	Power Well:	Core

Software can read the registers at offsets 04h, 05h and 06h simultaneously by performing a single, 32-bit read from address offset 04h. Software can also read this register individually by doing a single, 8-bit read to offset 04h. Reads across DWord boundaries are not supported.

Bit	Description
7:5	Hardwired to 0.
4:0	Current Index Value [4:0] — RO. These bits represent which buffer descriptor within the list of 16 descriptors is being processed currently. As each descriptor is processed, this value is incremented.

15.2.3 x_LVI—Last Valid Index Register

I/O Address:	MBAR + 05h (MILVI), MBAR + 15h (MOLVI)	Attribute:	R/W
Default Value:	00h	Power Well:	Core

Software can read the registers at offsets 04h, 05h and 06h simultaneously by performing a single, 32-bit read from address offset 04h. Software can also read this register individually by doing a single, 8-bit read to offset 05h. Reads across DWord boundaries are not supported.

Bit	Description
7:5	Hardwired to 0
4:0	Last Valid Index [4:0] — R/W. These bits indicate the last valid descriptor in the list. This value is updated by the software as it prepares new buffers and adds to the list.

15.2.4 x_SR—Status Register

I/O Address:	MBAR + 06h (MISR), MBAR + 16h (MOSR)	Attribute:	R/WC, RO
Default Value:	0001h	Size:	16 bits
Lockable:	No	Power Well:	Core

Software can read the registers at offsets 04h, 05h and 06h simultaneously by performing a single, 32-bit read from address offset 04h. Software can also read this register individually by doing a single, 16-bit read to offset 06h. Reads across DWord boundaries are not supported.

Bit	Description
15:5	Reserved
4	<p>FIFO Error (FIFOE) — R/WC. 0 = Cleared by writing a 1 to this bit position. 1 = FIFO error occurs.</p> <ul style="list-style-type: none"> Modem in: FIFO error indicates a FIFO overrun. The FIFO pointers don't increment, the incoming data is not written into the FIFO, thereby being lost. Modem out: FIFO error indicates a FIFO underrun. The sample transmitted in this case should be the last valid sample. <p>The ICH4 will set the FIFOE bit if the under-run or overrun occurs when there are more valid buffers to process.</p>
3	<p>Buffer Completion Interrupt Status (BCIS) — R/WC. 0 = Cleared by writing a 1 to this bit position. 1 = Set by the hardware after the last sample of a buffer has been processed, AND if the Interrupt on Completion (IOC) bit is set in the command byte of the buffer descriptor. Remains active until software clears bit.</p>
2	<p>Last Valid Buffer Completion Interrupt (LVBCI) — R/WC. 0 = Cleared by writing a 1 to this bit position 1 = Set by hardware when last valid buffer has been processed. It remains active until cleared by software. This bit indicates the occurrence of the event signified by the last valid buffer being processed. Thus, this is an event status bit that can be cleared by software once this event has been recognized. This event will cause an interrupt if the enable bit in the Control Register is set. The interrupt is cleared when the software clears this bit.</p> <p>In the case of transmits (PCM out, Modem out) this bit is set, after the last valid buffer has been fetched (not after transmitting it). While in the case of Receives, this bit is set after the data for the last buffer has been written to memory.</p>
1	<p>Current Equals Last Valid (CELV) — RO. 0 = Hardware clears when controller exists state (i.e., until a new value is written to the LVI register). 1 = Current Index is equal to the value in the Last Valid Index Register, AND the buffer pointed to by the CIV has been processed (i.e., after the last valid buffer has been processed). This bit is very similar to bit 2, except, this bit reflects the state rather than the event. This bit reflects the state of the controller, and remains set until the controller exits this state.</p>
0	<p>DMA Controller Halted (DCH)— RO. 0 = Running. 1 = Halted. This could happen because of the Start/Stop bit being cleared and the DMA engines are idle, or it could happen once the controller has processed the last valid buffer.</p>

15.2.5 x_PICB—Position in Current Buffer Register

I/O Address:	MBAR + 08h (MIPICB), MBAR + 18h (MOPICB),	Attribute:	RO
Default Value:	0000h	Size:	16 bits
Lockable:	No	Power Well:	Core

Software can read the registers at the offsets 08h, 0Ah, and 0Bh by performing a 32-bit read from the address offset 08h. Software can also read this register individually by doing a single, 16-bit read to offset 08h. Reads across DWord boundaries are not supported.

Bit	Description
15:0	Position In Current Buffer [15:0] — RO. These bits represent the number of samples left to be processed in the current buffer.

15.2.6 x_PIV—Prefetch Index Value Register

I/O Address:	MBAR + 0Ah (MIPIV), MBAR + 1Ah (MOPIV)	Attribute:	RO
Default Value:	00h	Size:	8 bits
Lockable:	No	Power Well:	Core

Software can read the registers at the offsets 08h, 0Ah, and 0Bh by performing a 32-bit read from the address offset 08h. Software can also read this register individually by doing a single, 8-bit read to offset 0Ah. Reads across DWord boundaries are not supported.

Bit	Description
7:5	Hardwired to 0
4:0	Prefetched Index Value [4:0] — RO. These bits represent which buffer descriptor in the list has been prefetched.

15.2.7 x_CR—Control Register

I/O Address:	MBAR + 0Bh (MICR), MBAR + 1Bh (MOCR)	Attribute:	R/W
Default Value:	00h	Size:	8 bits
Lockable:	No	Power Well:	Core

Software can read the registers at the offsets 08h, 0Ah, and 0Bh by performing a 32-bit read from the address offset 08h. Software can also read this register individually by doing a single, 8-bit read to offset 0Bh. Reads across DWord boundaries are not supported.

Bit	Description
7:5	Reserved
4	Interrupt On Completion Enable (IOCE) — R/W. This bit controls whether or not an interrupt occurs when a buffer completes with the IOC bit set in its descriptor. 0 = Disable 1 = Enable
3	FIFO Error Interrupt Enable (FEIE) — R/W. This bit controls whether the occurrence of a FIFO error will cause an interrupt or not. 0 = Disable. Bit 4 in the Status Register will be set, but the interrupt will not occur. 1 = Enable. Interrupt will occur
2	Last Valid Buffer Interrupt Enable (LVBIE) — R/W. This bit controls whether the completion of the last valid buffer will cause an interrupt or not. 0 = Disable. Bit 2 in the Status register will still be set, but the interrupt will not occur. 1 = Enable
1	Reset Registers (RR) — R/W-Special. 0 = Removes reset condition. 1 = Contents of all registers to be reset, except the interrupt enable bits (bit 4,3,2 of this register). Software needs to set this bit. It must be set only when the Run/Pause bit is cleared. Setting it when the Run bit is set will cause undefined consequences. This bit is self-clearing (software needs not clear it).
0	Run/Pause Bus Master (RPBM) — R/W. 0 = Pause bus master operation. This results in all state information being retained (i.e., master mode operation can be stopped and then resumed). 1 = Run. Bus master operation starts.

15.2.8 GLOB_CNT—Global Control Register

I/O Address:	MBAR + 3Ch	Attribute:	R/W
Default Value:	00000000h	Size:	32 bits
Lockable:	No	Power Well:	Core

Reads across DWord boundaries are not supported.

Bit	Description
31:7	Reserved.
6	AC_SDIN2 Interrupt Enable (S2RE) — R/W. 0 = Disable. 1 = Enable an interrupt to occur when the codec on AC_SDIN[2] causes a resume event on the AC-link.
5	AC_SDIN1 Resume Interrupt Enable (S1RE) — R/W. 0 = Disable. 1 = Enable an interrupt to occur when the codec on AC_SDIN[1] causes a resume event on the AC-link.
4	AC_SDIN0 Resume Interrupt Enable (S0RE) — R/W. 0 = Disable. 1 = Enable an interrupt to occur when the codec on AC_SDIN[0] causes a resume event on the AC-link.
3	ACLINK Shut Off (LSO) — R/W. 0 = Normal operation. 1 = Controller disables all outputs which will be pulled low by internal pull down resistors.
2	AC '97 Warm Reset — R/W-Special. 0 = Normal operation. 1 = Writing a 1 to this bit causes a warm reset to occur on the AC-link. The warm reset will awaken a suspended codec without clearing its internal registers. If software attempts to perform a warm reset while bit_clk is running, the write will be ignored and the bit will not change. This bit is self-clearing (it remains set until the reset completes and bit_clk is seen on the ACLink, after which it clears itself).
1	AC '97 Cold Reset# — R/W. 0 = Writing a 0 to this bit causes a cold reset to occur throughout the AC '97 circuitry. All data in the controller and the codec will be lost. Software needs to clear this bit no sooner than the minimum number of ms have elapsed. 1 = This bit defaults to 0 and hence after reset, the driver needs to set this bit to a 1. The value of this bit is retained after suspends; hence, if this bit is set to a 1 prior to suspending, a cold reset is not generated automatically upon resuming. NOTE: This bit is in the Core well.
0	GPI Interrupt Enable (GIE) — R/W. This bit controls whether the change in status of any GPI causes an interrupt. 0 = Bit 0 of the Global Status Register is set, but no interrupt is generated. 1 = The change on value of a GPI causes an interrupt and sets bit 0 of the Global Status Register.

15.2.9 GLOB_STA—Global Status Register

I/O Address:	MBAR + 40h	Attribute:	RO, R/W, R/WC
Default Value:	00300000h	Size:	32 bits
Lockable:	No	Power Well:	Core

On reads from a codec, the controller will give the codec a maximum of 4 frames to respond, after which if no response is received, it will return a dummy read completion to the processor (with all F's on the data) and also set the Read Completion Status bit in the Global Status Register.

Reads across DWord boundaries are not supported.

Bit	Description
31:30	Reserved.
29	AC_SDIN2 Resume Interrupt (S2RI) — R/WC. This bit indicates that a resume event occurred on AC_SDIN[2]. 0 = Cleared by writing a 1 to this bit position. 1 = Resume event occurred. This bit is not affected by D3 _{HOT} to D0 Reset.
28	AC_SDIN2 Codec Ready (S2CR) — RO. Reflects the state of the codec ready bit in AC_SDIN[2]. Bus masters ignore the condition of the codec ready bits, so software must check this bit before starting the bus masters. Once the codec is “ready”, it must never go “not ready” spontaneously. 0 = Not Ready. 1 = Ready.
27	Bit Clock Stopped (BCS) — RO. Indicates that the bit clock is not running. 0 = Running. It is cleared if a transition is found on BIT_CLK. 1 = Stopped. This bit is set if the ICH4 detects that there has been no transition on BIT_CLK for four consecutive PCI clocks.
26	S/PDIF Interrupt (SPINT) — RO. 0 = When the specific status bit is cleared, this bit will be cleared. 1 = Indicates that the S/PDIF out channel interrupt status bits have been set.
25	PCM In 2 Interrupt (P2INT) — RO. 0 = When the specific status bit is cleared, this bit will be cleared. 1 = Indicates that one of the PCM In 2 channel status bits have been set.
24	Microphone 2 In Interrupt (M2INT) — RO. 0 = When the specific status bit is cleared, this bit will be cleared. 1 = Indicates that one of the Mic in channel interrupts status bits has been set.
23:22	Sample Capabilities — RO. Indicates the capability to support more greater than 16-bit audio. 00 = Reserved 01 = 16 and 20-bit Audio supported (ICH4 value) 10 = Reserved 11 = Reserved
21:20	Multichannel Capabilities — RO. Indicates the capability to support more 4 and 6 channels on PCM Out.
19:18	Reserved.
17	MD3 — R/W. Power down semaphore for Modem. This bit exists in the suspend well and maintains context across power states (except G3). The bit has no hardware function. It is used by software in conjunction with the AD3 bit to coordinate the entry of the two codecs into D3 state. This bit is not affected by D3 _{HOT} to D0 Reset.
16	AD3 — R/W. Power down semaphore for Audio. This bit exists in the suspend well and maintains context across power states (except G3). The bit has no hardware function. It is used by software in conjunction with the MD3 bit to coordinate the entry of the two codecs into D3 state. This bit is not affected by D3 _{HOT} to D0 Reset.

Bit	Description
15	Read Completion Status (RCS) — R/WC. This bit indicates the status of codec read completions. 0 = A codec read completes normally. 1 = A codec read results in a time-out. The bit remains set until being cleared by software writing a 1 to the bit location. This bit is not affected by D3 _{HOT} to D0 Reset.
14	Bit 3 of slot 12 — RO. Display bit 3 of the most recent slot 12.
13	Bit 2 of slot 12 — RO. Display bit 2 of the most recent slot 12.
12	Bit 1 of slot 12 — RO. Display bit 1 of the most recent slot 12.
11	AC_SDIN1 Resume Interrupt (S1RI) — R/WC. This bit indicates that a resume event occurred on AC_SDIN[1]. 0 = Cleared by writing a 1 to this bit position. 1 = Resume event occurred. This bit is not affected by D3 _{HOT} to D0 Reset.
10	AC_SDIN0 Resume Interrupt (S0RI) — R/WC. This bit indicates that a resume event occurred on AC_SDIN[0]. 0 = Cleared by writing a 1 to this bit position. 1 = Resume event occurred. This bit is not affected by D3 _{HOT} to D0 Reset.
9	AC_SDIN1 Codec Ready (S1CR) — RO. Reflects the state of the codec ready bit in AC_SDIN[1]. Bus masters ignore the condition of the codec ready bits, so software must check this bit before starting the bus masters. Once the codec is “ready”, it must never go “not ready” spontaneously. 0 = Not Ready. 1 = Ready.
8	AC_SDIN0 Codec Ready (S0CR) — RO. Reflects the state of the codec ready bit in AC_SDIN [0]. Bus masters ignore the condition of the codec ready bits, so software must check this bit before starting the bus masters. Once the codec is “ready”, it must never go “not ready” spontaneously. 0 = Not Ready. 1 = Ready.
7	Mic In Interrupt (MINT) — RO. 0 = When the specific status bit is cleared, this bit will be cleared. 1 = This bit indicates that one of the Mic in channel interrupts status bits has been set.
6	PCM Out Interrupt (POINT) — RO. 0 = When the specific status bit is cleared, this bit will be cleared. 1 = This bit indicates that one of the PCM out channel interrupts status bits has been set.
5	PCM In Interrupt (PIINT) — RO. 0 = When the specific status bit is cleared, this bit will be cleared. 1 = This bit indicates that one of the PCM in channel interrupts status bits has been set.
4:3	Reserved
2	Modem Out Interrupt (MOINT) — RO. 0 = When the specific status bit is cleared, this bit will be cleared. 1 = This bit indicates that one of the modem out channel interrupts status bits has been set.
1	Modem In Interrupt (MIINT) — RO. 0 = When the specific status bit is cleared, this bit will be cleared. 1 = This bit indicates that one of the modem in channel interrupts status bits has been set.
0	GPI Status Change Interrupt (GSCI) — RWC. 0 = The bit is cleared by software writing a 1 to this bit location. 1 = This bit reflects the state of bit 0 in slot 12, and is set when bit 0 of slot 12 is set. This indicates that one of the GPIs changed state, and that the new values are available in slot 12. This bit is not affected by D3 _{HOT} to D0 Reset.

15.2.10 CAS—Codec Access Semaphore Register

I/O Address:	NABMBAR + 44h	Attribute:	R/W
Default Value:	00h	Size:	8 bits
Lockable:	No	Power Well:	Core

Reads across DWord boundaries are not supported.

Bit	Description
7:1	Reserved
0	<p>Codec Access Semaphore (CAS) — R/W-Special. This bit is read by software to check whether a codec access is currently in progress.</p> <p>0 = No access in progress.</p> <p>1 = The act of reading this register sets this bit to 1. The driver that read this bit can then perform an I/O access. Once the access is completed, hardware automatically clears this bit.</p>

Ballout Definition

16

This section contains the ICH4 ballout information. [Figure 16-1](#) and [Figure 16-2](#) provide a graphical illustration of how the ballout maps to the 421 BGA package. [Table 16-1](#) provides the BGA ball list, sorted alphabetically by signal name.

Figure 16-1. Intel® ICH4 Ballout (Topview—Left Side)

	1	2	3	4	5	6	7	8	9	10	11	12		
A	Vss	REQ1#	PIRQD#	Vss	Vcc3_3	REQB#/ REQ5# / GPIO1	GNT2#	EE_DOUT	LAN_RXD1	LAN_RXD0	LAN_RXD2	LAN_TXD2		
B	REQ0#	Vcc3_3	REQ2#	PIRQC#	REQA# / GPIO0	REQ4#	GNT3#	AC_BIT_CLK	Vss	LAN_TXD0	LAN_RSTSYNC	Vss		
C	GNT0#	PIRQB#	PIRQG# / GPIO4	PIRQH# / GPIO5	GNTB# / GNT5#/ GPIO17	Vss	REQ3#	PIRQE# / GPIO2	AC_SYNC	LAN_TXD1	LAN_CLK	EE_SHCLK		
D	Vss	AD30	AD28	Vss	PIRQA#	GNT4#	PIRQF# / GPIO3	Vss	AC_SDOOUT	EE_CS	EE_DIN	Vss		
E	AD26	AD24	AD20	AD22	AD18	GNT1#	V5REF	GNTA# / GPIO16	VccSus3_3	Vss	VccSus3_3	VccSus1_5		
F	FRAME#	TRDY#	STOP#	AD16	AD15	VccSus1_5	VccSus1_5	Vss	VccSus3_3	VccSus3_3				
G	PAR	AD9	Vss	AD11	AD4	Vss								
H	Vss	AD13	AD2	AD6	AD0	Vcc3_3								
J	Vcc3_3	C/BE0#	AD1	AD5	AD7	Vss								
K	AD3	AD8	Vss	C/BE1#	SERR#	Vcc3_3						Vcc1_5	Vss	Vcc1_5
L	AD10	AD12	AD14	PERR#	IRDY#						Vss	Vss	Vss	
M	Vss	PLOCK#	DEVSEL#	C/BE2#	AD23						Vcc3_3	Vss	Vss	
N	AD17	AD19	AD21	C/BE3#	Vss						Vss	Vss	Vss	
P	AD25	AD27	Vss	AD31	PCICLK	Vcc3_3						Vcc1_5	Vss	Vcc3_3
R	AD29	GPIO6	GPIO7	LAD1 / FWH1	Vss	VccSus1_5								
T	Vss	LAD0 / FWH0	GPIO21	LAD2 / FWH2	LFRAME# / FWH4	VccSus1_5								
U	Vcc3_3	LAD3 / FWH3	LDRQ0#	LDRQ1#	PCIRST#	VccSus1_5								
V	THRM#	GPIO25	Vss	GPIO8	GPIO12	V5REF	VccSus3_3	VccSus3_3	VccSus3_3	Vcc3_3				
W	GPIO27	PME#	GPIO13	GPIO28	Vss	INTRUDER#	RTCST#	Vss	PDD11	PDD13	PDD14	PDIOW#		
Y	R#	SLP_S4#	SYS_RESET#	SLP_S3#	LAN_RST#	VBIAS	Vss	PDD6	PDD9	PDD2	PDD15	PDDACK#		
AA	PWRBNT#	SLP_S5#	Vss	SUSCLK	SMBALERT# / GPIO11	RSMRST#	PDD4	PDD7	Vss	PDD3	PDDREQ	Vss		
AB	SMLINK1	TP0	SUS_STAT# / LPCPD#	SMBDATA	VccRTC	PWROK	Vss	PDD5	PDD8	PDD12	PDD0	PIORDY		
AC	Vss	GPIO24	SMLINK0	SMBCLK	Vss	RTCX2	RTCX1	Vcc3_3	PDD10	Vss	PDD1	PDIOR#		
	1	2	3	4	5	6	7	8	9	10	11	12		

Figure 16-2. Intel® ICH4 Ballout (Topview—Right Side)

13	14	15	16	17	18	19	20	21	22	23	
AC_SDIN1	OC4#	OC2#	Vss	USBP5P	Vss	USBP3P	Vss	USBP1P	Vss	USBRBIAS	A
AC_SDIN2	OC3#	OC0#	Vss	USBP5N	Vss	USBP3N	Vss	USBP1N	Vss	USBRBIAS#	B
AC_RST#	OC1#	Vss	USBP4P	Vss	USBP2P	Vss	USBP0P	Vss	VccPLL	Vss	C
AC_SDIN0	OC5#	Vss	USBP4N	Vss	USBP2N	Vss	USBP0N	Vss	Vss	Vss	D
VccSus1_5	Vss	V5REF_Sus	Vss	Vss	Vss	Vss	VccSus1_5	Vss	Vss	GPIO43	E
	VccSus1_5	VccSus3_3	VccSus3_3	VccSus3_3	VccSus3_3	CLK48	GPIO34	GPIO36	GPIO42	GPIO38	F
					VccSus1_5	Vss	GPIO35	Vss	GPIO33	GPIO40	G
					Vcc3_3	APICD0	GPIO37	GPIO41	GPIO39	SPKR	H
					Vcc3_3	APICCLK	GPIO32	GPIO23	SERIRQ	CLK14	J
					Vcc1_5	Vss	APICD1	HI11	Vcc1_5	Vss	K
						HI0	HI1	Vss	HI9	VccHI	L
						HI2	Vss	HI3	Vss	HIREF	M
						Vss	HI_STB# / HI_STBF	Vss	HI10	Vss	N
					VccHI	HI4	Vss	HI_STB / HI_STBS	Vss	HI8	P
					Vss	HI5	HI7	Vss	HI_VSWING	HICOMP	R
					Vcc1_5	Vss	HI6	CLK66	VccHI	Vss	T
					V_CPU_IO	Vcc1_5	Vss	CPUSLP#	RCIN#	NC	U
	Vcc1_5	Vss	Vcc3_3	Vss	Vcc3_3	VRMPWRGD	NC	NMI	INIT#	STPCLK#	V
PDA2	SDD6	SDD4	SDD2	SDD0	GPIO19	GPIO20	THRMTRIP#	IGNNE#	Vss	SMI#	W
PDCS1#	SDD8	SDD11	SDD13	SDD15	SDIOR#	Vss	GPIO22	GPIO18	A20GATE	CPUPWRGD	Y
PDA0	SDD7	SDD10	Vss	SDD14	SDIOW#	IRQ15	SDA0	FERR#	Vss	V_CPU_IO	AA
PDA1	PDCS3#	SDD5	SDD12	SDD1	SDDREQ	SDDACK#	Vss	SDCS1#	INTR	A20M#	AB
IRQ14	Vss	SDD9	SDD3	Vcc3_3	Vss	SIORDY	SDA1	SDA2	SDCS3#	Vss	AC

Vss	VccSus3_3
Vss	Vss
Vss	VccHI
Vss	Vss
Vss	V_CPU_IO

Table 16-1. Intel® ICH4
Ball List

Signal Name	Ball #
A20GATE	Y22
A20M#	AB23
AC_BIT_CLK	B8
AC_RST#	C13
AC_SDIN0	D13
AC_SDIN1	A13
AC_SDIN2	B13
AC_SDOUT	D9
AC_SYNC	C9
AD0	H5
AD1	J3
AD2	H3
AD3	K1
AD4	G5
AD5	J4
AD6	H4
AD7	J5
AD8	K2
AD9	G2
AD10	L1
AD11	G4
AD12	L2
AD13	H2
AD14	L3
AD15	F5
AD16	F4
AD17	N1
AD18	E5
AD19	N2
AD20	E3
AD21	N3
AD22	E4
AD23	M5
AD24	E2
AD25	P1
AD26	E1
AD27	P2
AD28	D3

Table 16-1. Intel® ICH4
Ball List

Signal Name	Ball #
AD29	R1
AD30	D2
AD31	P4
APICCLK	J19
APICD0	H19
APICD1	K20
C/BE0#	J2
C/BE1#	K4
C/BE2#	M4
C/BE3#	N4
CLK14	J23
CLK48	F19
CLK66	T21
CPUPWRGD	Y23
CPUSLP#	U21
DEVSEL#	M3
EE_CS	D10
EE_DIN	D11
EE_DOUT	A8
EE_SHCLK	C12
FERR#	AA21
FRAME#	F1
GNT0#	C1
GNT1#	E6
GNT2#	A7
GNT3#	B7
GNT4#	D6
GNTA#/GPIO16	E8
GNTB#/GNT5#/ GPIO17	C5
GPIO6	R2
GPIO7	R3
GPIO8	V4
GPIO12	V5
GPIO13	W3
GPIO18	Y21
GPIO19	W18
GPIO20	W19

Table 16-1. Intel® ICH4
Ball List

Signal Name	Ball #
GPIO21	T3
GPIO22	Y20
GPIO23	J21
GPIO24	AC2
GPIO25	V2
GPIO27	W1
GPIO28	W4
GPIO32	J20
GPIO33	G22
GPIO34	F20
GPIO35	G20
GPIO36	F21
GPIO37	H20
GPIO38	F23
GPIO39	H22
GPIO40	G23
GPIO41	H21
GPIO42	F22
GPIO43	E23
HI_STB#/HI_STBF	N20
HI_STB/HI_STBS	P21
HI_VSWING	R22
HI0	L19
HI1	L20
HI2	M19
HI3	M21
HI4	P19
HI5	R19
HI6	T20
HI7	R20
HI8	P23
HI9	L22
HI10	N22
HI11	K21
HICOMP	R23
HIREF	M23
IGNNE#	W21
INIT#	V22

Table 16-1. Intel® ICH4 Ball List

Signal Name	Ball #
INTR	AB22
INTRUDER#	W6
IRDY#	L5
IRQ14	AC13
IRQ15	AA19
LAD0/FWH0	T2
LAD1/FWH1	R4
LAD2/FWH2	T4
LAD3/FWH3	U2
LAN_CLK	C11
LAN_RST#	Y5
LAN_RSTSYNC	B11
LAN_RXD0	A10
LAN_RXD1	A9
LAN_RXD2	A11
LAN_TXD0	B10
LAN_TXD1	C10
LAN_TXD2	A12
LDRQ0#	U3
LDRQ1#	U4
LFRAME# / FWH4	T5
NMI	V21
OC0#	B15
OC1#	C14
OC2#	A15
OC3#	B14
OC4#	A14
OC5#	D14
PAR	G1
PCICLK	P5
PCIRST#	U5
PDA0	AA13
PDA1	AB13
PDA2	W13
PDCS1#	Y13
PDCS3#	AB14
PDD0	AB11
PDD1	AC11

Table 16-1. Intel® ICH4 Ball List

Signal Name	Ball #
PDD2	Y10
PDD3	AA10
PDD4	AA7
PDD5	AB8
PDD6	Y8
PDD7	AA8
PDD8	AB9
PDD9	Y9
PDD10	AC9
PDD11	W9
PDD12	AB10
PDD13	W10
PDD14	W11
PDD15	Y11
PDDACK#	Y12
PDDREQ	AA11
PDIOR#	AC12
PDIOV#	W12
PERR#	L4
PIORDY	AB12
PIRQA#	D5
PIRQB#	C2
PIRQC#	B4
PIRQD#	A3
PIRQE#/GPIO2	C8
PIRQF#/GPIO3	D7
PIRQG#/GPIO4	C3
PIRQH#/GPIO5	C4
PLOCK#	M2
PME#	W2
PWRBTN#	AA1
PWROK	AB6
RCIN#	U22
REQ0#	B1
REQ1#	A2
REQ2#	B3
REQ3#	C7
REQ4#	B6

Table 16-1. Intel® ICH4 Ball List

Signal Name	Ball #
REQA#/GPIO0	B5
REQB#/REQ5#/GPIO1	A6
NC	V20
NC	U23
RI#	Y1
RSMRST#	AA6
RTCRST#	W7
RTCX1	AC7
RTCX2	AC6
SDA0	AA20
SDA1	AC20
SDA2	AC21
SDCS1#	AB21
SDCS3#	AC22
SDD0	W17
SDD1	AB17
SDD2	W16
SDD3	AC16
SDD4	W15
SDD5	AB15
SDD6	W14
SDD7	AA14
SDD8	Y14
SDD9	AC15
SDD10	AA15
SDD11	Y15
SDD12	AB16
SDD13	Y16
SDD14	AA17
SDD15	Y17
SDDACK#	AB19
SDDREQ	AB18
SDIOR#	Y18
SDIOV#	AA18
SERIRQ	J22
SERR#	K5
SIORDY	AC19

Table 16-1. Intel® ICH4
Ball List

Signal Name	Ball #
SLP_S3#	Y4
SLP_S4#	Y2
SLP_S5#	AA2
SMBALERT#/GPIO11	AA5
SMBCLK	AC4
SMBDATA	AB4
SMI#	W23
SMLINK0	AC3
SMLINK1	AB1
SPKR	H23
STOP#	F3
STPCLK#	V23
SUS_STAT#/LPCPD#	AB3
SUSCLK	AA4
SYS_RESET#	Y3
THRM#	V1
THRMTRIP#	W20
TP[0]	AB2
TRDY#	F2
USBP0N	D20
USBP0P	C20
USBP1N	B21
USBP1P	A21
USBP2N	D18
USBP2P	C18
USBP3N	B19
USBP3P	A19
USBP4N	D16
USBP4P	C16
USBP5N	B17
USBP5P	A17
USBRBIAS	A23
USBRBIAS#	B23
V_CPU_IO	AA23
V_CPU_IO	P14
V_CPU_IO	U18
V5REF	E7
V5REF	V6

Table 16-1. Intel® ICH4
Ball List

Signal Name	Ball #
V5REF_Sus	E15
VBIAS	Y6
Vcc1_5	K10
Vcc1_5	K12
Vcc1_5	K18
Vcc1_5	K22
Vcc1_5	P10
Vcc1_5	T18
Vcc1_5	U19
Vcc1_5	V14
Vcc3_3	A5
Vcc3_3	AC17
Vcc3_3	AC8
Vcc3_3	B2
Vcc3_3	H18
Vcc3_3	H6
Vcc3_3	J1
Vcc3_3	J18
Vcc3_3	K6
Vcc3_3	M10
Vcc3_3	P12
Vcc3_3	P6
Vcc3_3	U1
Vcc3_3	V10
Vcc3_3	V16
Vcc3_3	V18
VccHI	L23
VccHI	M14
VccHI	P18
VccHI	T22
VccPLL	C22
VccRTC	AB5
VccSus1_5	F6
VccSus1_5	F7
VccSus1_5	E12
VccSus1_5	E13
VccSus1_5	E20
VccSus1_5	F14

Table 16-1. Intel® ICH4
Ball List

Signal Name	Ball #
VccSus1_5	G18
VccSus1_5	R6
VccSus1_5	T6
VccSus1_5	U6
VccSus3_3	E9
VccSus3_3	F9
VccSus3_3	E11
VccSus3_3	F10
VccSus3_3	F15
VccSus3_3	F16
VccSus3_3	F17
VccSus3_3	F18
VccSus3_3	K14
VccSus3_3	V7
VccSus3_3	V8
VccSus3_3	V9
VRMPWRGD	V19
Vss	A1
Vss	A16
Vss	A18
Vss	A20
Vss	A22
Vss	A4
Vss	AA12
Vss	AA16
Vss	AA22
Vss	AA3
Vss	AA9
Vss	AB20
Vss	AB7
Vss	AC1
Vss	AC10
Vss	AC14
Vss	AC18
Vss	AC23
Vss	AC5
Vss	B12
Vss	B16

Table 16-1. Intel® ICH4 Ball List

Signal Name	Ball #
Vss	B18
Vss	B20
Vss	B22
Vss	B9
Vss	C15
Vss	C17
Vss	C19
Vss	C21
Vss	C23
Vss	C6
Vss	D1
Vss	D12
Vss	D15
Vss	D17
Vss	D19
Vss	D21
Vss	D23
Vss	D4
Vss	D8
Vss	E10
Vss	E14
Vss	E16
Vss	E17
Vss	E18
Vss	E19
Vss	E21
Vss	E22

Table 16-1. Intel® ICH4 Ball List

Signal Name	Ball #
Vss	F8
Vss	G19
Vss	G21
Vss	G3
Vss	G6
Vss	H1
Vss	J6
Vss	K11
Vss	K13
Vss	K19
Vss	K23
Vss	K3
Vss	L10
Vss	L11
Vss	L12
Vss	L13
Vss	L14
Vss	L21
Vss	M1
Vss	M11
Vss	M12
Vss	M13
Vss	M20
Vss	M22
Vss	N10
Vss	N11
Vss	N12

Table 16-1. Intel® ICH4 Ball List

Signal Name	Ball #
Vss	N13
Vss	N14
Vss	N19
Vss	N21
Vss	N23
Vss	N5
Vss	P11
Vss	P13
Vss	P20
Vss	P22
Vss	P3
Vss	R18
Vss	R21
Vss	R5
Vss	T1
Vss	T19
Vss	T23
Vss	U20
Vss	V15
Vss	V17
Vss	V3
Vss	W22
Vss	W5
Vss	W8
Vss	Y19
Vss	Y7
Vss	D22

This page is intentionally left blank

Electrical Characteristics

17

This chapter provides the absolute maximum ratings, DC characteristics, AC characteristics, and AC timing diagrams.

17.1 Absolute Maximum Ratings

Parameter	Maximum Limits
Voltage on Any 3.3 V Pin with Respect to Ground	-0.5 to Vcc3_3 + 0.5 V
Voltage on Any 5 V Tolerant Pin with Respect to Ground (VREF=5V)	-0.5 to VREF + 0.5 V
1.5 V Supply Voltage with Respect to Vss	-0.5 to +2.1 V
1.8 V Supply Voltage with Respect to Vss	-0.5 to +2.1 V
3.3 V Supply Voltage with Respect to Vss	-0.5 to +4.6 V
5.0 V Supply Voltage (Vref) with Respect to Vss	-0.5 to +5.5 V

Warning: Stressing the device beyond the “Absolute Maximum Ratings” may cause permanent damage. These are stress ratings only. See [Section 17.2](#) for the Functional Operating Range of the ICH4.

Note: A non-condensing environment is required to maintain RTC accuracy.

17.2 Functional Operating Range

All of the AC and DC Characteristics specified in this document assume that the ICH4 component is operating within the Functional Operating Range given in this section. Operation outside of the Functional Operating Range is not recommended, and extended exposure outside of the Functional Operating Range may affect component reliability.

1.5 V Supply Voltage (Vcc1_5, VccHI, VccSus1_5) with respect to Vss	1.425 V to 1.575 V
1.8 V Supply Voltage (VccHI when operating in HI 1.0 mode) with respect to Vss	1.71 V to 1.89 V
3.3 V Supply Voltage (Vcc3_3, VccSus3_3) with respect to Vss	3.135 V to 3.465 V
5 V Supply Voltage (V5REF, V5REF_Sus) with respect to Vss	4.75 V to 5.25 V
V_CPU_IO Voltage with respect to Vss	0.8 V—1.75 V

17.3 DC Characteristics

Table 17-1. DC Current Characteristics

Power Plane	Maximum Power Consumption				
	SO	S1	S3	S4/S5	G3
Vcc1_5 Core	550 mA	266 mA	N/A	N/A	N/A
Vcc3_3 I/O	528 mA	0.8 mA	N/A	N/A	N/A
VccSus1_5	87.3 mA ⁽¹⁾	54 mA	15.6 mA	15.6 mA	N/A
VccSus3_3	168 mA ⁽¹⁾	2.5 mA	2.3 mA	2.3 mA	N/A
VccHI (HI 1.0 Mode – 1.8 V)	132 mA	132 mA	N/A	N/A	N/A
VccHI (HI 1.5 Mode – 1.5 V)	99 mA	99 mA	N/A	N/A	N/A
V_CPU_IO	2.5 mA	2.5 mA	N/A	N/A	N/A
V5REF	10 μ A	10 μ A	N/A	N/A	N/A
V5REF_Sus	10 μ A	10 μ A	10 μ A	10 μ A	N/A
VccRTC	N/A	N/A	N/A	N/A	5 μ A ⁽²⁾

NOTES:

- This number assumes 6 high-speed ports transmitting and receiving.
- Icc(RTC) data is taken with Vcc(RTC) at 3.0 V while the system is in a mechanical off (G3) state at room temperature.

Table 17-2. DC Characteristic Input Signal Association (Sheet 1 of 2)

Symbol	Associated Signals
V_{IH1}/V_{IL1} (5 V Tolerant)	PCI Signals: AD[31:0], C/BE[3:0]#, DEVSEL#, FRAME#, IRDY#, TRDY#, STOP#, PAR, PERR#, PLOCK#, SERR#, REQ[4:0]# PC/PCI Signals: REQ[A]#/GPIO[0], REQ[B]#/REQ[5]#/GPIO[1]
V_{IH2}/V_{IL2} (5 V Tolerant)	Interrupt Signals: IRQ[15:14], PIRQ[D:A]#, PIRQ[H:E]#/GPIO[5:2] Legacy Signals: RCIN#, A20GATE GPIO Signals: GPIO[7:6];
V_{IH3}/V_{IL3}	Clock Signals: CLK66, CLK48, CLK14 Interrupt Signals: SERIRQ Power Management Signals: PME#, PWRBTN#, RI#, LAN_RST#, SYS_RESET#, THRM#, VRMPWRGD EEPROM Signals: EE_DIN GPIO Signals: GPIO[43:32, 28:27, 25:24, 13:12, 8];
V_{IH4}/V_{IL4}	Clock Signals: PCICLK LPC/FWH Signals: LDRQ[1:0]#, LAD[3:0]/FWH[3:0]
V_{IH5}/V_{IL5}	SMBus Signals: SMBCLK, SMBDATA System Management Signals: INTRUDER#, SMLINK[1:0], SMBALERT#/GPIO[11] Power Management Signals: RSMRST#, PWROK Miscellaneous Signal: RTCRST#
V_{IL6}/V_{IH6}	LAN Signals: LAN_RXD[2:0], LAN_CLK
V_{IL7}/V_{IH7}	CPU Signals: FERR#, THRMTRIP#
V_{IL8}/V_{IH8}	Hub Interface Signals: HI[11:0], HI_STB / HI_STBS, HI_STB# / HI_STBF

Table 17-2. DC Characteristic Input Signal Association (Sheet 2 of 2)

Symbol	Associated Signals
V_{IL9}/V_{IH9}	Real Time Clock Signals: RTCX1
V_{IL10}/V_{IH10}	APIC Signals: APICD[1:0]
V_{IL11}/V_{IH11} (5 V Tolerant)	USB Signals: OC[5:0]#
V_{IL12}/V_{IH12}	AC '97 Signals: AC_BITCLK, AC_SDIN[2:0]
V_{IL13}/V_{IH13}	Clock Signals: APICCLK
$V_+/V_-/V_{HYS}/V_{THRAVG}/V_{RING}$ (5 V Tolerant)	IDE Signals: PDD[15:0], SDD[15:0], PDDREQ, PIORDY, SDDREQ, SIORDY For Ultra DMA Mode 4 and lower these signals follow the DC characteristics for V_{IH2}/V_{IL2}
$V_{DI}/V_{CM}/V_{SE}$	USB Signals: USBP[5:0][P,N] (Low-speed and Full-speed)
$V_{HSSQ}/V_{HSDSC}/V_{HSCM}$	USB Signals: USBP[5:0][P,N] (in High-speed Mode)

Table 17-3. DC Input Characteristics (Sheet 1 of 2)

Symbol	Parameter	Min	Max	Unit	Notes
V_{IL1}	Input Low Voltage	-0.5	$0.3V_{CC3_3}$	V	
V_{IH1}	Input High Voltage	$0.5V_{CC3_3}$	$V_{5REF} + 0.5$	V	
V_{IL2}	Input Low Voltage	-0.5	0.8	V	
V_{IH2}	Input High Voltage	2.0	$V_{5REF} + 0.5$	V	
V_{IL3}	Input Low Voltage	-0.5	0.8	V	
V_{IH3}	Input High Voltage	2.0	$V_{CC3_3} + 0.5$	V	
V_{IL4}	Input Low Voltage	-0.5	$0.3V_{CC3_3}$	V	
V_{IH4}	Input High Voltage	$0.5V_{CC3_3}$	$V_{CC3_3} + 0.5$	V	
V_{IL5}	Input Low Voltage	-0.5	0.8	V	
V_{IH5}	Input High Voltage	2.1	$V_{CCSus3_3} + 0.5$	V	
V_{IL6}	Input Low Voltage	-0.5	$0.3V_{CC3_3}$	V	
V_{IH6}	Input High Voltage	$0.6V_{CC3_3}$	$V_{CC3_3} + 0.5$	V	
V_{IL7}	Input Low Voltage	-0.15	$0.58(V_{CPU_IO})$	V	
V_{IH7}	Input High Voltage	$0.73(V_{CPU_IO})$	V_{CPU_IO}	V	
V_{IL8}	Input Low Voltage	-0.5	$HIREF - 0.15$	V	HI 1.0 Mode
		-0.3	$HIREF - 0.10$		HI 1.5 Mode
V_{IH8}	Input High Voltage	$HIREF + 0.20$	$V_{CCHI} + 0.5$	V	HI 1.0 Mode
		$HIREF + 0.10$	1.2		HI 1.5 Mode
V_{IL9}	Input Low Voltage	-0.5	0.10	V	
V_{IH9}	Input High Voltage	0.40	1.0	V	
V_{IL10}	Input Low Voltage	-0.15	.7	V	

Table 17-3. DC Input Characteristics (Sheet 2 of 2)

Symbol	Parameter	Min	Max	Unit	Notes
V_{IH10}	Input High Voltage	1.25	2.1	V	
V_{IL11}	Input Low Voltage	-0.5	0.8	V	
V_{IH11}	Input High Voltage	2.0	$V5REF_SUS + 0.5$	V	
V_{IL12}	Input Low Voltage	-0.5	$0.35V_{cc3_3}$	V	
V_{IH12}	Input High Voltage	$0.65V_{cc3_3}$	$V_{cc3_3} + 0.3$	V	
V_{IL13}	Input Low Voltage	-0.5	0.7	V	
V_{IH13}	Input High Voltage	2.0	3.28	V	
V+	Low to high input threshold	1.5	2.0	V	1
V-	High to low input threshold	1.0	1.5	V	1
VHYS	Difference between input thresholds: (V+current value) – (V-current value)	320		mV	1
VTHRAVG	Average of thresholds: ((V+current value) + (V-current value))/2	1.3	1.7	V	1
VRING	AC Voltage at recipient connector	-1	6	V	1,2
V_{DI}	Differential Input Sensitivity	0.2		V	3,5
V_{CM}	Differential Common Mode Range	0.8	2.5	V	4,5
V_{SE}	Single-Ended Receiver Threshold	0.8	2.0	V	5
V_{HSSQ}	HS Squelch Detection Threshold	100	150	mV	5
V_{HSDSC}	HS Disconnect Detection Threshold	525	625	mV	5
V_{HSCM}	HS Data Signaling Common Mode Voltage Range	-50	500	mV	5
V_{HSSQ}	HS Squelch detection threshold	100	150	mV	5
V_{HSDSC}	HS disconnect detection threshold	525	625	mV	5
V_{HSCM}	HS data signaling common mode voltage range	-50	500	mV	5

NOTES:

1. Applies to Ultra DMA Modes greater than Ultra DMA Mode 4
2. This is an AC Characteristic that represents transient values for these signals
3. $V_{DI} = |USBPx[P] - USBPx[N]|$
4. Includes V_{DI} range
5. Applies to high-speed USB 2.0

Table 17-4. DC Characteristic Output Signal Association

Symbol	Associated Signals
V_{OH1}/V_{OL1}	IDE Signals: PDD[15:0], SDD[15:0], PDIOW#/PDSTOP, SDIOW#/SDSTOP, PDIOR#/PDWSTB/PRDMARDY, SDIOR#/STWSTB/SRDMARDY, PDDACK#, SDDACK#, PDA[2:0], SDA[2:0], PDCS[3,1]#, SDCS[3,1]#
V_{OH2}/V_{OL2}	CPU Signals: A20M#, CPUPWRGD ⁽¹⁾ , CPUSLP#, IGNNE#, INIT#, INTR, NMI, SMI#, STPCLK#
V_{OH3}/V_{OL3}	EEPROM Signals: EE_CS, EE_DOUT, EE_SHCLK
V_{OH4}/V_{OL4}	PCI Signals: GNT5#/GNTB#/GPIO17, GNTA#/GPIO16, AD[31:0], C/BE[3:0]#, PCIRST#, GNT[4:0]#, PAR, DEVSEL#, PERR#, PLOCK#, STOP#, TRDY#, IRDY#, FRAME#, SERR# ⁽¹⁾ LPC/FWH Signals: LAD[3:0]/FWH[3:0], LFRAME#/FWH[4] AC '97 Signals: AC_RST#, AC_SDOOUT, AC_SYNC LAN Signals: LAN_RSTSYNC, LAN_TXD[2:0]
V_{OL5}/V_{OH5}	SMBus Signals: SMBCLK ⁽¹⁾ , SMBDATA ⁽¹⁾ System Management Signals: SMLINK[1:0] ⁽¹⁾
V_{OL6}/V_{OH6}	Power Management Signals: SLP_S3#, SLP_S4#, SLP_S5#, SUS_STAT#, SUSCLK GPIO Signals: GPIO[43:32, 28:27, 25:22, 21:18]; Interrupt Signals: SERIRQ, PIRQ[D:A]# ⁽¹⁾ , PIRQ[H:E]#/GPIO[5:2] ⁽¹⁾ Other Signals: SPKR
V_{OL7}/V_{OH7}	USB Signals: USBP[5:0][P,N] in Low and Full Speed Modes
V_{OL8}/V_{OH8} Zpd/Zpu	Hub Interface Signals: HI[11:0], HI_STB / HI_STBS, HI_STB# / HI_STBF
V_{OL9}/V_{OH9}	Interrupt Signals: APICD[1:0] ⁽¹⁾
V_{HSOI} V_{HSOH} V_{HSOL} V_{CHIRPJ} V_{CHIRPK}	USB Signals: USBP[5:0][P,N] in High Speed Modes

NOTE: 1. These signals are open drain.

Table 17-5. DC Output Characteristics

Symbol	Parameter	Min	Max	Unit	I_{OL}/I_{OH}	Notes
V_{OL1}	Output Low Voltage		0.51	V	6 mA	
V_{OH1}	Output High Voltage	$V_{cc3_3} - 0.51$		V	-6 mA	
V_{OL2}	Output Low Voltage	-0.15	$0.25(V_{CPU_IO})$	V	1.5 mA	
V_{OH2}	Output High Voltage	$0.9(V_{CPU_IO})$		V	-0.5 mA	1
V_{OL3}	Output Low Voltage		0.4	V	6 mA	
V_{OH3}	Output High Voltage	2.4		V	-1 mA	1
V_{OL4}	Output Low Voltage		0.55	V	6 mA	
V_{OH4}	Output High Voltage	$0.9V_{cc3_3}$		V	-0.5 mA	1
V_{OL5}	Output Low Voltage		0.4	V	4.0 mA	
V_{OH5}	Output High Voltage	N/A		V		1
V_{OL6}	Output Low Voltage		0.4	V	4.0 mA	
V_{OH6}	Output High Voltage	$V_{cc3_3} - 0.5$		V	-2.0 mA	1
V_{OL7}	Output Low Voltage		0.4	V	5 mA	
V_{OH7}	Output High Voltage	$V_{cc3_3} - 0.5$		V	-2 mA	
V_{OL8}	Output Low Voltage		$0.1(V_{ccHI})$	V	1 mA	HI 1.0 Mode
			0.05	V	1 mA	HI 1.5 Mode
V_{OH8}	Output High Voltage	$0.9(V_{ccHI})$		V	-1 mA	HI 1.0 Mode
		$V_{SWING} - 50\text{ mV}$	$V_{SWING} + 50\text{ mV}$	V	-12 mA	HI 1.5 Mode Terminator High Voltage Note 2
		$V_{SWING} - 50\text{ mV}$	$V_{SWING} + 50\text{ mV}$	V	-12 mA	HI 1.5 Mode Output High Voltage Note 3
Z_{pd}	Pull Down Impedance	38		Ohm	$V_{out} = 0.5V_{ccHI}$	HI 1.0 Mode
		48		Ohm	$V_{out} = 0.7V$	HI 1.5 Mode
Z_{pu}	Pull Up Impedance	38		Ohm	$V_{out} = 0.5V_{ccHI}$	HI 1.0 Mode
		46		Ohm	$V_{out} = 0.7V$	HI 1.5 Mode
V_{HSOI}	HS Idle Level	-10.0	10.0	mV		
V_{HSOH}	HS Data Signaling High	360	440	mV		
V_{HSOL}	HS Data Signaling Low	-10.0	10.0	mV		
V_{CHIRPJ}	Chirp J Level	700	1100	mV		
V_{CHIRPK}	Chirp K Level	-900	-500	mV		

NOTES:

1. The CPUPWRGD, SERR#, PME#, PIRQ[A:H], GPIO[22], APIC[1:0], SMBDATA, SMBCLK and SMLINK[1:0] signal has an open drain driver, and the V_{OH} spec does not apply. This signal must have external pull up resistor.
2. The condition for the Terminator High Voltage is $ZPD = ZTARG(V_{ccHI}/V_{SWING} - 1)$.
3. The condition for the Output High Voltage is $ZPD = ZTARG$.

Table 17-6. Other DC Characteristics

Symbol	Parameter	Min	Max	Unit	Notes
V5REF	ICH4 Core Well Reference Voltage	4.75	5.25	V	
Vcc3_3	I/O Buffer Voltage	3.135	3.465	V	
V_CPU_IO	CPU Interface Voltage	0.8	1.75	V	
Vcc1_5, VccHI(HI 1.5), VccPLL	Internal Logic Voltage	1.425	1.575	V	
VccHI(HI 1.0)	Internal HI 1.0 Logic Voltage	1.71	1.89	V	
HIREF	Hub Interface Reference Voltage	0.48(VccHI)	0.52(VccHI)	V	HI 1.0 Mode
		0.343	0.357	V	HI 1.5 Mode
V5REF_Sus	Suspend Well Reference Voltage	4.75	5.25	V	
VccSus3_3	Suspend Well I/O Buffer Voltage	3.135	3.465	V	
VccSus1_5	Suspend Well Logic Voltage	1.425	1.575	V	
VccRTC	Battery Voltage	2.0	3.6	V	
VIT+	Hysteresis Input Rising Threshold	1.9		V	Applied to USBP[5:0][P,N]
VIT-	Hysteresis Input Falling Threshold		1.3	V	Applied to USBP[5:0]P,N]
VDI	Differential Input Sensitivity	0.2		V	(USBPx+,USBPx-)
VCM	Differential Common Mode Range	0.8	2.5	V	Includes VDI
VCRS	Output Signal Crossover Voltage	1.3	2.0	V	
VSE	Single Ended Rcvr Threshold	0.8	2.0	V	
ILI1	ATA Input Leakage Current	-200	200	μA	(0 V < VIN < 5V)
ILI2	PCI_3V Hi-Z State Data Line Leakage	-10	10	μA	(0 V < VIN < 3.3V)
ILI3	PCI_5V Hi-Z State Data Line Leakage	-70	70	μA	Max VIN = 2.7 V Min VIN = 0.5 V
ILI4	Input Leakage Current - Clock signals	-100	+100	μA	See Note
CIN	Input Capacitance - Hub interface		8	pF	FC = 1 MHz
	Input Capacitance - All Other		12	pF	
COUT	Output Capacitance		12	pF	FC = 1 MHz
C _{I/O}	I/O Capacitance		12	pF	FC = 1 MHz
		Typical Value			
CL	XTAL1		6	pF	
CL	XTAL2		6	pF	

NOTE: Includes APICCLK, CLK14, CLK48, CLK66, LAN_CLK, and PCICLK

17.4 AC Characteristics

Table 17-7. AC Input Characteristics

Type	Signals	Maximum Voltage	Pulse Duration	Notes
Undershoot	INTRUDER#, PWROK, RTCRST#, RSMRST#	-0.6 V	20 ns	
Rise/Fall Slew Rate	INTRUDER#, PWROK, RSMRST#	40 mV/ μ s		

Table 17-8. Clock Timings (Sheet 1 of 2)

Sym	Parameter	Min	Max	Unit	Notes	Figure
PCI Clock (PCICLK)						
t1	Period	30	33.3	ns		17-1
t2	High Time	12		ns		17-1
t3	Low Time	12		ns		17-1
t4	Rise Time		3	ns		17-1
t5	Fall Time		3	ns		17-1
Oscillator Clock (OSC)						
t6	Period	67	70	ns		17-1
t7	High Time	20				17-1
t8	Low Time	20		ns		17-1
USB Clock (USBCLK)						
f _{clk48}	Operating Frequency	48		MHz	1	
t9	Frequency Tolerance		500	ppm	2	
t10	High Time	7		ns		17-1
t11	Low Time	7		ns		17-1
t12	Rise Time		1.2	ns		17-1
t13	Fall Time		1.2	ns		17-1
SUSCLK						
f _{SUSclk}	Operating Frequency	32		kHz	6	
t14	High Time	10		μ s	6	
t15	Low Time	10		μ s	6	
SMBus Clock (SMBCLK)						
f _{smb}	Operating Frequency	10	16	KHz		
t18	High time	4.0	50	μ s	3	17-17
t19	Low time	4.7		μ s		17-17
t20	Rise time		1000	ns		17-17
t21	Fall time		300	ns		17-17

Table 17-8. Clock Timings (Sheet 2 of 2)

Sym	Parameter	Min	Max	Unit	Notes	Figure
I/O APIC Clock (APICCLK)						
f _{ioap}	Operating Frequency	14.32	33.33	MHz		
t ₂₂	High time	12	36	ns		17-1
t ₂₃	Low time	12	36	ns		17-1
t ₂₄	Rise time	1.0	5.0	ns		17-1
t ₂₅	Fall time	1.0	5.0	ns		17-1
AC '97 Clock (BITCLK)						
f _{ac97}	Operating Frequency	12.288		MHz		
t ₂₆	Output Jitter		750	ps		
t ₂₇	High time	32.56	48.84	ns		17-1
t ₂₈	Low time	32.56	48.84	ns		17-1
t ₂₉	Rise time	2.0	6.0	ns	4	17-1
t ₃₀	Fall time	2.0	6.0	ns	4	17-1
Hub Interface Clock						
f _{hi}	Operating Frequency	66		MHz		
t ₃₁	High time	6.0		ns		17-1
t ₃₂	Low time	6.0		ns		17-1
t ₃₃	Rise time	0.25	1.2	ns		17-1
t ₃₄	Fall time	0.25	1.2	ns		17-1
t ₃₅	CLK66 leads PCICLK	1.0	4.5	ns	5	
PCI Clock (PCICLK)						
t ₁	Period	30	33.3	ns		17-1
t ₂	High Time	12		ns		17-1

NOTES:

1. The USBCLK is a 48 MHz that expects a 40/60% duty cycle.
2. USBCLK is a pass-thru clock that is not altered by the ICH4. This frequency tolerance specification is required for USB 1.1 compliance and is affected by external elements such as the clock generator and the system board.
3. The maximum high time (t₁₈ Max) provide a simple guaranteed method for devices to detect bus idle conditions.
4. BITCLK Rise and Fall times are measured from 10%VDD and 90%VDD.
5. This specification includes pin-to-pin skew from the clock generator as well as board skew.
6. SUSCLK duty cycle can range from 30% minimum to 70% maximum.

Table 17-9. PCI Interface Timing

Sym	Parameter	Min	Max	Units	Notes	Figure
t40	AD[31:0] Valid Delay	2	11	ns	Min: 0 pF Max: 50 pF	17-3
t41	AD[31:0] Setup Time to PCICLK Rising	7		ns		17-4
t42	AD[31:0] Hold Time from PCICLK Rising	0		ns		17-4
t43	C/BE[3:0]#, FRAME#, TRDY#, IRDY#, STOP#, PAR, PERR#, PLOCK#, DEVSEL# Valid Delay from PCICLK Rising	2	11	ns	Min: 0 pF Max: 50 pF	17-3
t44	C/BE[3:0]#, FRAME#, TRDY#, IRDY#, STOP#, PAR, PERR#, PLOCK#, IDSEL, DEVSEL# Output Enable Delay from PCICLK Rising	2		ns		17-7
t45	C/BE[3:0]#, FRAME#, TRDY#, IRDY#, STOP#, PERR#, PLOCK#, DEVSEL#, GNT[A:B]# Float Delay from PCICLK Rising	2	28	ns		17-5
t46	C/BE[3:0]#, FRAME#, TRDY#, IRDY#, STOP#, SERR#, PERR#, DEVSEL#, Setup Time to PCICLK Rising	7		ns		17-4
t47	C/BE[3:0]#, FRAME#, TRDY#, IRDY#, STOP#, SERR#, PERR#, DEVSEL#, REQ[A:B]# Hold Time from PCLKIN Rising	0		ns		17-4
t48	PCIRST# Low Pulse Width	1		ms		17-6
t49	GNT[A:B]#, GNT[5:0]# Valid Delay from PCICLK Rising	2	12	ns		
t50	REQ[A:B]#, REQ[5:0]# Setup Timer to PCICLK Rising	12		ns		

Table 17-10. IDE PIO and Multiword DMA Mode Timing

Sym	Parameter	Min	Max	Units	Notes	Figure
t60	PDIOR#/PDIOW#/SDIOR#/SDIOW# Active From CLK66 Rising	2	20	ns		17-8,17-9
t61	PDIOR#/PDIOW#/SDIOR#/SDIOW# Inactive From CLK66 Rising	2	20	ns		17-8,17-9
t62	PDA[2:0]/SDA[2:0] Valid Delay From CLK66 Rising	2	30	ns		17-8
t63	PDCS1#/SDCS1#, PDCS3#/SDCS3# Active From CLK66 Rising	2	30	ns		17-8
t64	PDCS1#/SDCS1#, PDCS3#/SDCS3# Inactive From CLK66 Rising	2	30	ns		17-8
t65	PDDACK#/SDDACK# Active From CLK66 Rising	2	20	ns		17-9
t66	PDDACK#/SDDACK# Inactive From CLK66 Rising	2	20	ns		
t67	PDDREQ/SDDREQ Setup Time to CLK66 Rising	7		ns		17-9
t68	PDDREQ/SDDREQ Hold From CLK66 Rising	7		ns		17-9
t69	PDD[15:0]/SDD[15:0] Valid Delay From CLK66 Rising	2	30	ns		17-8,17-9
t70	PDD[15:0]/SDD[15:0] Setup Time to CLK66 Rising	10		ns		17-8,17-9
t71	PDD[15:0]/SDD[15:0] Hold From CLK66 Rising	7		ns		17-8,17-9
t72	PIORDY/SIORDY Setup Time to CLK66 Rising	7		ns	1	17-8
t73	PIORDY/SIORDY Hold From CLK66 Rising	7		ns	1	17-8
t74	PIORDY/SIORDY Inactive Pulse Width	48		ns		17-8
t75	PDIOR#/PDIOW#/SDIOR#/SDIOW# Pulse Width Low				2,3	17-8,17-9
t76	PDIOR#/PDIOW#/SDIOR#/SDIOW# Pulse Width High				3,4	17-8,17-9

NOTES:

1. IORDY is internally synchronized. This timing is to guarantee recognition on the next clock.
2. PIORDY sample point from DIOx# assertion and PDIOx# active pulse width is programmable from 2–5 PCI clocks when the drive mode is Mode 2 or greater. Refer to the ISP field in the IDE Timing Register
3. PIORDY sample point from DIOx# assertion, PDIOx# active pulse width and PDIOx# inactive pulse width cycle time is the compatible timing when the drive mode is Mode 0/1. Refer to the TIM0/1 field in the IDE timing register.
4. PDIOx# inactive pulse width is programmable from 1–4 PCI clocks when the drive mode is Mode 2 or greater. Refer to the RCT field in the IDE Timing Register.

Table 17-11. Ultra ATA Timing (Mode 0, Mode 1, Mode 2)

Sym	Parameter (1)	Mode 0 (ns)		Mode 1 (ns)		Mode 2 (ns)		Measuring Location	Figure
		Min	Max	Min	Max	Min	Max		
t80	Sustained Cycle Time (T2cyc _{typ})	240		160		120		Sender Connector	
t81	Cycle Time (T _{cyc})	112		73		54		End Recipient Connector	17-11
t82	Two Cycle Time (T2cyc)	230		153		115		Sender Connector	17-11
t83a	Data Setup Time (T _{ds})	15		10		7		Recipient Connector	17-11
t83b	Recipient IC data setup time (from data valid until STROBE edge) (see Note 2) (T _{dsic})	14.7		9.7		6.8		ICH4 ball	
t84a	Data Hold Time (T _{dh})	5		5		5		Recipient Connector	17-11
t84b	Recipient IC data hold time (from STROBE edge until data may become invalid) (see Note 2) (T _{dhic})	4.8		4.8		4.8		ICH4 ball	
t85a	Data Valid Setup Time (T _{dvs})	70		48		31		Sender Connector	17-11
t85b	Sender IC data valid setup time (from data valid until STROBE edge) (see Note 2) (T _{dvsic})	72.9		50.9		33.9		ICH4 ball	
t86a	Data Valid Hold Time (T _{dvh})	6.2		6.2		6.2		Sender Connector	17-11
t86b	Sender IC data valid hold time (from STROBE edge until data may become invalid) (see Note 2) (T _{dvhic})	9		9		9		ICH4 ball	
t87	Limited Interlock Time (T _{li})	0	150	0	150	0	150	See Note 2	17-13
t88	Interlock Time w/ Minimum (T _{mli})	20		20		20		Host Connector	17-13
t89	Envelope Time (T _{env})	20	70	20	70	20	70	Host Connector	17-10
t90	Ready to Pause Time (T _{rp})	160		125		100		Recipient Connector	17-12
t91	DMACK setup/hold Time (T _{ack})	20		20		20		Host Connector	17-10, 17-13
t92a	CRC Word Setup Time at Host (T _{cv_s})	70		48		31		Host Connector	
t92b	CRC word valid hold time at sender (from DMACK# negation until CRC may become invalid) (see Note 2) (T _{cv_h})	6.2		6.2		6.2		Host Connector	

Table 17-11. Ultra ATA Timing (Mode 0, Mode 1, Mode 2)

Sym	Parameter (1)	Mode 0 (ns)		Mode 1 (ns)		Mode 2 (ns)		Measuring Location	Figure
		Min	Max	Min	Max	Min	Max		
t93	STROBE output released-to-driving to the first transition of critical timing (Tzfs)	0		0		0		Device Connector	
t94	Data Output Released-to-Driving Until the First Transition of Critical Timing (Tdzfs)	70		48		31		Sender Connector	
t95	Unlimited Interlock Time (Tui)	0		0		0		Host Connector	
t96a	Maximum time allowed for output drivers to release (from asserted or negated) (Taz)		10		10		10	See Note 2	
t96b	Minimum time for drivers to assert or negate (from released) (Tzad)	0		0		0		Device Connector	
t97	Ready-to-final-STROBE time (no STROBE edges shall be sent this long after negation of DMARDY#) (Trfs)		75		70		60	Sender Connector	
t98a	Maximum time before releasing IORDY (Tiordyz)		20		20		20	Device Connector	
t98b	Minimum time before driving IORDY (see Note 2) (Tziordy)	0		0		0		Device Connector	
t99	Time from STROBE edge to negation of DMARQ or assertion of STOP (when sender terminates a burst) (Tss)	50		50		50		Sender Connector	

NOTES:

1. The specification symbols in parentheses correspond to the AT Attachment - 6 with Packet Interface (ATA/ATAPI - 6) specification name.
2. See the *AT Attachment - 6 with Packet Interface (ATA/ATAPI - 6)* Specification for further details on measuring these timing parameters.

Table 17-12. Ultra ATA Timing (Mode 3, Mode 4, Mode 5)

Sym	Parameter (1)	Mode 3 (ns)		Mode 4 (ns)		Mode 5 (ns)		Measuring Location	Figure
		Min	Max	Min	Max	Min	Max		
t80	Sustained Cycle Time (T2cyctyp)	90		60		40		Sender Connector	
t81	Cycle Time (Tcyc)	39		25		16.8		End Recipient Connector	17-11
t82	Two Cycle Time (T2cyc)	86		57		38		Sender Connector	17-11
t83	Data Setup Time (Tds)	7		5		4.0		Recipient Connector	17-11
t83b	Recipient IC data setup time (from data valid until STROBE edge) (see Note 2) (Tdsic)	6.8		4.8		2.3		ICH4 Balls	
t84	Data Hold Time (Tdh)	5		5		4.6		Recipient Connector	17-11
t84b	Recipient IC data hold time (from STROBE edge until data may become invalid) (see Note 2) (Tdhic)	4.8		4.8		2.8		ICH4 Balls	
t85	Data Valid Setup Time (Tdvs)	20		6.7		4.8		Sender Connector	17-11
t85b	Sender IC data valid setup time (from data valid until STROBE edge) (see Note 2) (Tdvsic)	22.6		9.5		6.0		ICH4 Balls	
t86	Data Valid Hold Time (Tdvh)	6.2		6.2		4.8		Sender Connector	17-11
t86b	Sender IC data valid hold time (from STROBE edge until data may become invalid) (see Note 2) (Tdvhic)	9.0		9.0		6.0		ICH4 Balls	
t87	Limited Interlock Time (Tli)	0	100	0	100	0	75	See Note 2	17-13
t88	Interlock Time w/ Minimum (Tmli)	20		20		20		Host Connector	17-13
t89	Envelope Time (Tenv)	20	55	20	55	20	50	Host Connector	17-10
t90	Ready to Pause Time (Trp)	100		100		85		Recipient Connector	17-12
t91	DMACK setup/hold Time (Tack)	20		20		20		Host Connector	17-10, 17-13
t92a	CRC Word Setup Time at Host (Tcvs)	20		6.7		10		Host Connector	

Table 17-12. Ultra ATA Timing (Mode 3, Mode 4, Mode 5)

Sym	Parameter (1)	Mode 3 (ns)		Mode 4 (ns)		Mode 5 (ns)		Measuring Location	Figure
		Min	Max	Min	Max	Min	Max		
t92b	CRC Word Hold Time at Sender CRC word valid hold time at sender (from DMACK# negation until CRC may become invalid) (see Note 2) (Tcvh)	6.2		6.2		10.0		Host Connector	
t93	STROBE output released-to-driving to the first transition of critical timing (Tzfs)	0		0		35		Device Connector	
t94	Data Output Released-to-Driving Until the First Transition of Critical Timing (Tdzfs)	20.0		6.7		25		Sender Connector	
t95	Unlimited Interlock Time (Tui)	0		0		0		Host Connector	
t96a	Maximum time allowed for output drivers to release (from asserted or negated) (Taz)		10		10		10	See Note 2	
t96b	Drivers to assert or negate (from released) (Tzad)	0		0		0		Device Connector	
t97	Ready-to-final-STROBE time (no STROBE edges shall be sent this long after negation of DMARDY#) (Trfs)		60		60		50	Sender Connector	
t98a	Maximum time before releasing IORDY (Tiordyz)		20		20		20	Device Connector	
t98b	Minimum time before driving IORDY (see Note 2) (Tziordy)	0		0		0		Device Connector	
t99	Time from STROBE edge to negation of DMARQ or assertion of STOP (when sender terminates a burst) (Tss)	50		50		50		Sender Connector	

NOTES:

1. The specification symbols in parentheses correspond to the AT Attachment - 6 with Packet Interface (ATA/ATAPI - 6) specification name.
2. See the AT Attachment - 6 with Packet Interface (ATA/ATAPI - 6) specification for further details on measuring these timing parameters.

Table 17-13. Universal Serial Bus Timing

Sym	Parameter	Min	Max	Units	Notes	Fig
Full Speed Source ⁽⁷⁾						
t100	USBPx+, USBPx- Driver Rise Time	4	20	ns	1, C _L = 50 pF	17-13
t101	USBPx+, USBPx- Driver Fall Time	4	20	ns	1, C _L = 50 pF	17-13
t102	Source Differential Driver Jitter To Next Transition For Paired Transitions	-3.5 -4	3.5 4	ns ns	2, 3	17-14
t103	Source SE0 interval of EOP	160	175	ns	4	17-15
t104	Source Jitter for Differential Transition to SE0 Transition	-2	5	ns	5	
t105	Receiver Data Jitter Tolerance To Next Transition For Paired Transitions	-18.5 -9	18.5 9	ns ns	3	17-14
t106	EOP Width: Must accept as EOP	82		ns	4	17-15
t107	Width of SE0 interval during differential transition		14	ns		
Low Speed Source ⁽⁸⁾						
t108	USBPx+, USBPx- Driver Rise Time	75	300	ns	1, 6 C _L = 50 pF C _L = 350 pF	17-13
t109	USBPx+, USBPx- Driver Fall Time	75	300	ns	1,6 C _L = 50 pF C _L = 350 pF	17-13
t110	Source Differential Driver Jitter To Next Transition For Paired Transitions	-25 -14	25 14	ns ns	2, 3	17-14
t111	Source SE0 interval of EOP	1.25	1.50	μs	4	17-15
t112	Source Jitter for Differential Transition to SE0 Transition	-40	100	ns	5	
t113	Receiver Data Jitter Tolerance To Next Transition For Paired Transitions	-152 -200	152 200	ns ns	3	17-14
t114	EOP Width: Must accept as EOP	670		ns	4	17-15
t115	Width of SE0 interval during differential transition		210	ns		

NOTES:

1. Driver output resistance under steady state drive is specified at 28 Ω at minimum and 43 Ω at maximum
2. Timing difference between the differential data signals
3. Measured at crossover point of differential data signals
4. Measured at 50% swing point of data signals
5. Measured from last crossover point to 50% swing point of data line at leading edge of EOP
6. Measured from 10% to 90% of the data signal
7. Full Speed Data Rate has minimum of 11.97 Mbps and maximum of 12.03 Mbps
8. Low Speed Data Rate has a minimum of 1.48 Mbps and a maximum of 1.52 Mbps

Table 17-14. IOAPIC Bus Timing

Sym	Parameter	Min	Max	Units	Notes	Fig
t120	APICCD[1:0]# Valid Delay from APICCLK Rising	3.0	12.0	ns		17-3
t121	APICCD[1:0]# Setup Time to APICCLK Rising	8.5		ns		17-4
t122	APICCD[1:0]# Hold Time from APICCLK Rising	3.0		ns		17-4

NOTE: The Min AC column indicates the minimum times required by the SMBus and/or I²C specifications. The ICH4 tolerates these timings on both its SMBus and SMLink interfaces.

Table 17-15. SMBus Timing

Sym	Parameter	Min	Max	Units	Notes	Fig
t130	Bus Tree Time Between Stop and Start Condition	4.7		μs		17-17
t131	Hold Time after (repeated) Start Condition. After this period, the first clock is generated.	4.0		μs		17-17
t132	Repeated Start Condition Setup Time	4.7		μs		17-17
t133	Stop Condition Setup Time	4.0		μs		17-17
t134	Data Hold Time	0		ns	4	17-17
t135	Data Setup Time	250		ns		17-17
t136	Device Time Out	25	35	ms	1	
t137	Cumulative Clock Low Extend Time (slave device)		25	ms	2	17-17
t138	Cumulative Clock Low Extend Time (master device)		10	ms	3	17-17

NOTES:

1. A device will timeout when any clock low exceeds this value.
2. t137 is the cumulative time a slave device is allowed to extend the clock cycles in one message from the initial start to stop. If a slave device exceeds this time, it is expected to release both its clock and data lines and reset itself.
3. t138 is the cumulative time a master device is allowed to extend its clock cycles within each byte of a message as defined from start-to-ack, ack-to-ack or ack-to-stop.
4. t134 has a minimum timing for I²C of 0 ns, while the minimum timing for SMBus is 300 ns.

Table 17-16. AC '97 Timing

Sym	Parameter	Min	Max	Units	Notes	Fig
t140	ACSDIN[2:0] Setup to Falling Edge of BITCLK	10		ns		17-23
t141	ACSDIN[2:0] Hold from Falling Edge of BITCLK	10		ns		17-23
t142	ACSYNC, ACSDOUT valid delay from rising edge of BITCLK		15	ns		17-23

Table 17-17. LPC Timing

Sym	Parameter	Min	Max	Units	Notes	Fig
t150	LAD[3:0] Valid Delay from PCICLK Rising	2	11	ns		17-3
t151	LAD[3:0] Output Enable Delay from PCICLK Rising	2		ns		17-7
t152	LAD[3:0] Float Delay from PCICLK Rising		28	ns		17-5
t153	LAD[3:0] Setup Time to PCICLK Rising	7		ns		17-4
t154	LAD[3:0] Hold Time from PCICLK Rising	0		ns		17-4
t155	LDRQ[1:0]# Setup Time to PCICLK Rising	12		ns		17-4
t156	LDRQ[1:0]# Hold Time from PCICLK Rising	0		ns		17-4
t157	LFRAME# Valid Delay from PCICLK Rising	2	12	ns		17-3

Table 17-18. Miscellaneous Timings

Sym	Parameter	Min	Max	Units	Notes	Fig
t160	SERIRQ Setup Time to PCICLK Rising	7		ns		17-4
t161	SERIRQ Hold Time from PCICLK Rising	0		ns		17-4
t162	RI#, EXTSMI#, GPI, USB Resume Pulse Width	2		RTCCLK		17-6
t163	SPKR Valid Delay from OSC Rising		200	ns		17-3
t164	SERR# Active to NMI Active		200	ns		
t165	IGNNE# Inactive from FERR# Inactive		230	ns		

Table 17-19. Power Sequencing and Reset Signal Timings

Sym	Parameter	Min	Max	Units	Notes	Fig
t170	VccRTC active to RTCRST# inactive	5	—	ms		17-18
t171	V5RefSus active to VccSus3_3, VccSus1_5 active	0	—	ms	1	17-18
t172	VccRTC supply active to VccSus supplies active	0	—	ms	2	17-18
t173	VccSus supplies active to LAN_RST# active, RSMRST# inactive	10	—	ms		17-18 17-20
t174	V5Ref active to Vcc3_3, Vcc1_5, VccHI active	0	—	ms	1	17-18
t175	VccSus supplies active to Vcc supplies active	0	—	ms	2	17-18
t176	Vcc supplies active to PWROK, VRMPWRGD active	10	—	ms		17-18 17-20
t177	PWROK and VRMPWRGD and SYS_RESET#inactive to SUS_STAT# inactive	32	38	RTCCLK		17-20
t178	SUS_STAT# inactive to PCIRST# inactive	1	3	RTCCLK		17-20
t179	AC_RST# active low pulse width	1		us		
t180	AC_RST# inactive to BIT_CLK startup delay	162.8		ns		

NOTES:

1. The V5Ref supply must power up before or simultaneous with its associated 3.3 V supply, and must power down simultaneous with or after the 3.3 V supply. See [Section 2.20.3](#) for details.
2. The VccSus supplies must **never** be active while the VccRTC supply is inactive. Likewise, the Vcc supplies must **never** be active while the VccSus supplies are inactive.

Table 17-20. Power Management Timings

Sym	Parameter	Min	Max	Units	Notes	Fig
t181	VccSus active to SLP_S5#, SUS_STAT# and PCIRST# active		50	ns		17-20
t182 t183	RSMRST# inactive to SUSCLK running, SLP_S5# inactive		110	ms	7	17-20
t183a	SLPS5# inactive to SLP_S4# inactive	1	2	RTCCLK		17-20
t183b	SLPS4# inactive to SLP_S3# inactive	1	2	RTCCLK		17-20
t184	Vcc active to STPCLK# and CPUSLP# inactive, and processor Frequency Strap signals high		50	ns		17-20
t185	PWROK and VRMPWRGD active and SYS_RESET# inactive to SUS_STAT# inactive and processor Frequency Straps latched to Strap Values	32	38	RTCCLK	1	17-20
t186	Processor Reset Complete to Frequency Strap signals unlatched from Strap Values	7	9	CLK66	2	17-20
t187	STPCLK# active to Stop Grant cycle	N/A	N/A		3	17-21
t188	Stop Grant cycle to CPUSLP# active	60	63	PCICLK	4	17-20 17-21
t189	S1 Wake Event to CPUSLP# inactive	1	25	PCICLK	4	17-20
t190	CPUSLP# inactive to STPCLK# inactive	3.87	245	μs		17-20
t192	CPUSLP# active to SUS_STAT# active	2	4	RTCCLK	1	17-21
t193	SUS_STAT# active to PCIRST# active	9	21	RTCCLK	1	17-21
t194	PCIRST# active to SLP_S3# active	1	2	RTCCLK	1	17-21
t194a	SLP_S3# active to SLP_S4# active	1	2	RTCCLK	1	17-21
t195	SLP_S4# active to SLP_S5# active	1	2	RTCCLK	1, 6	17-21
t196	SLP_S3# active to PWROK, VRMPWRGD inactive	0		ms	5	17-21
t197	PWROK, VRMPWRGD inactive to Vcc supplies inactive	20		ns		17-21
t198	Wake Event to SLP_S5# inactive	1	10	RTCCLK	1	
t198a	Wake Event to SLP_S4# inactive (S4 Wake)	1	10	RTCCLK	1	
t198b	Wake Event to SLP_S3# inactive (S3 Wake)	1	10	RTCCLK	1	
t198d	SLP_S5# inactive to SLP_S4# inactive	1	2	RTCCLK	1	17-21
t198e	SLP_S4# inactive to SLP_S3# inactive	1	2	RTCCLK	1	17-21
t204	CPU I/F signals latched prior to STPCLK# active	0	4	CLK66	2	17-22
t205	Break Event to STPCLK# inactive	30	3120	ns		17-22
t206	STPCLK# inactive to processor I/F signals unlatched	240	1880	ns		17-22
t220	THRMTRIP# active to SLP_S3#, SLP_S4#, SLP_S5# active		2	PCI CLK		

NOTES:

- These transitions are clocked off the internal RTC. 1 RTC clock is approximately 32 μs.
- This transition is clocked off the 66 MHz CLK66. 1 CLK66 is approximately 15 ns.
- The ICH4 STPCLK# assertion will trigger the processor to send a stop grant acknowledge cycle. The timing for this cycle getting to the ICH4 is dependant on the processor and the memory controller.
- These transitions are clocked off the 33 MHz PCICLK. 1 PCICLK is approximately 30 ns.
- The ICH4 has no maximum timing requirement for this transition. It is up to the system designer to determine if the SLP_S3#, SLP_S4# and SLP_S5# signals are used to control the power planes.

6. If the transition to S5 is due to Power Button Override, SLP_S3#, SLP_S4# and SLP_S5# are asserted together similar to timing t194 (PCIRST# active to SLP_S3# active).
7. If there is no RTC battery in the system, so VccRTC and the VccSus supplies come up together, the delay from RTCRST# and RSMRST# inactive to SUSCLK toggling may be as much as 2.5 seconds.
8. This value is programmable in multiples of 1024 PCI CLKs. Maximum is 8192 PCI CLKs (245.6 μ s).

17.5 Timing Diagrams

Figure 17-1. Clock Timing

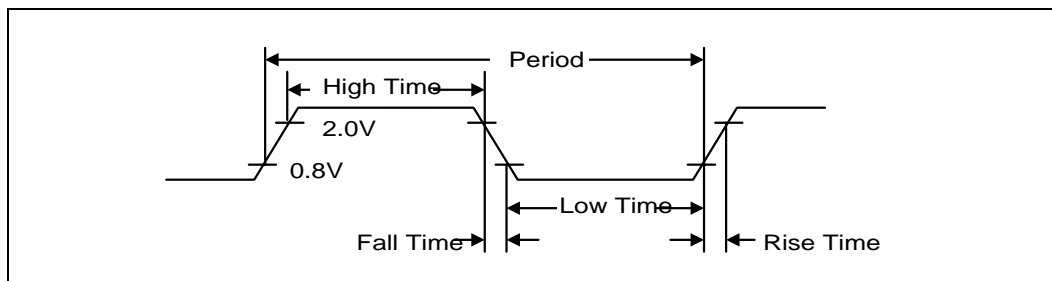

Figure 17-2. Valid Delay from Rising Clock Edge

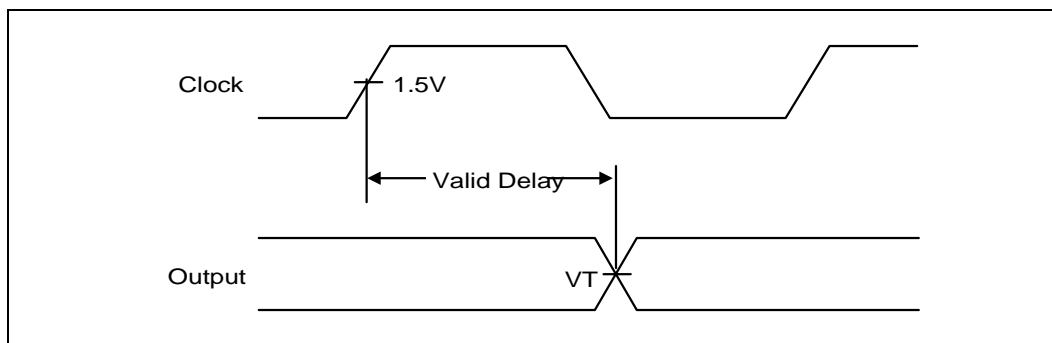

Figure 17-3. Setup and Hold Times

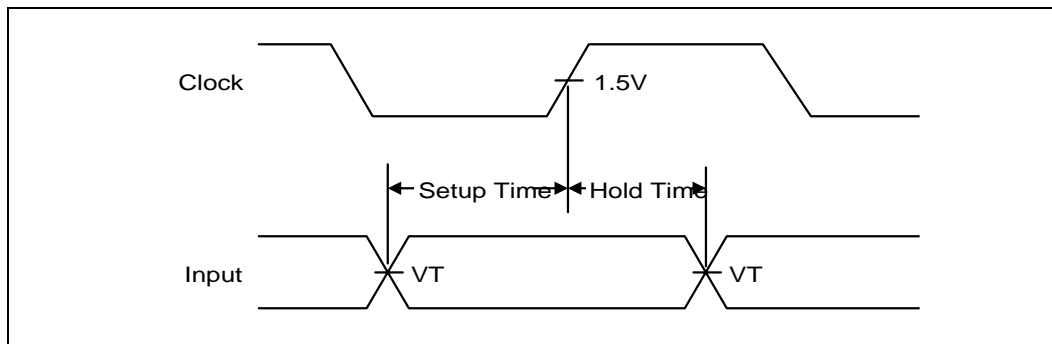

Figure 17-4. Float Delay

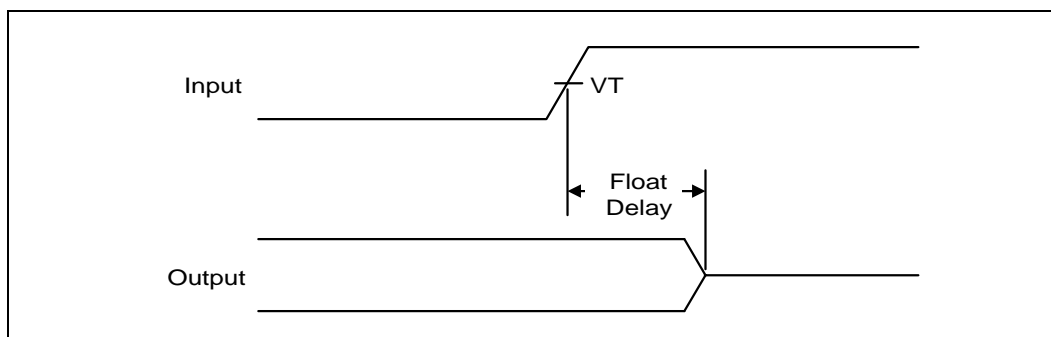

Figure 17-5. Pulse Width

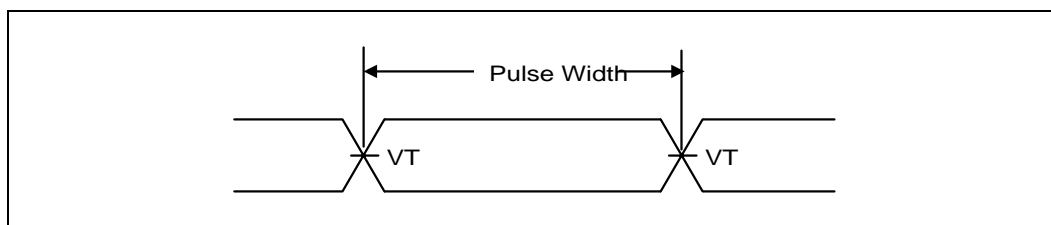

Figure 17-6. Output Enable Delay

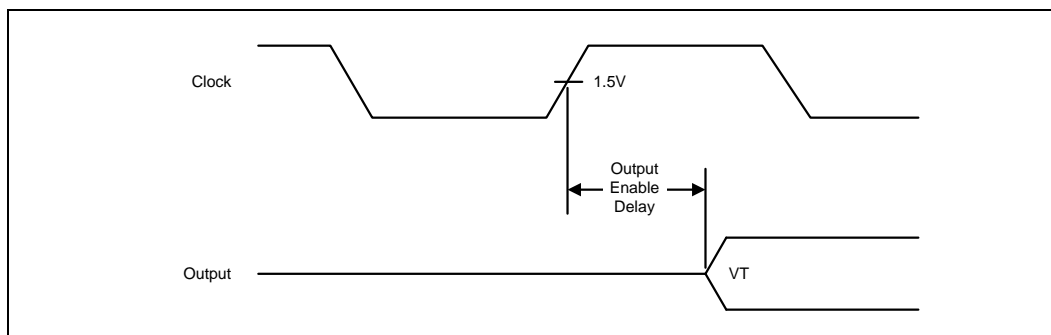

Figure 17-7. IDE PIO Mode

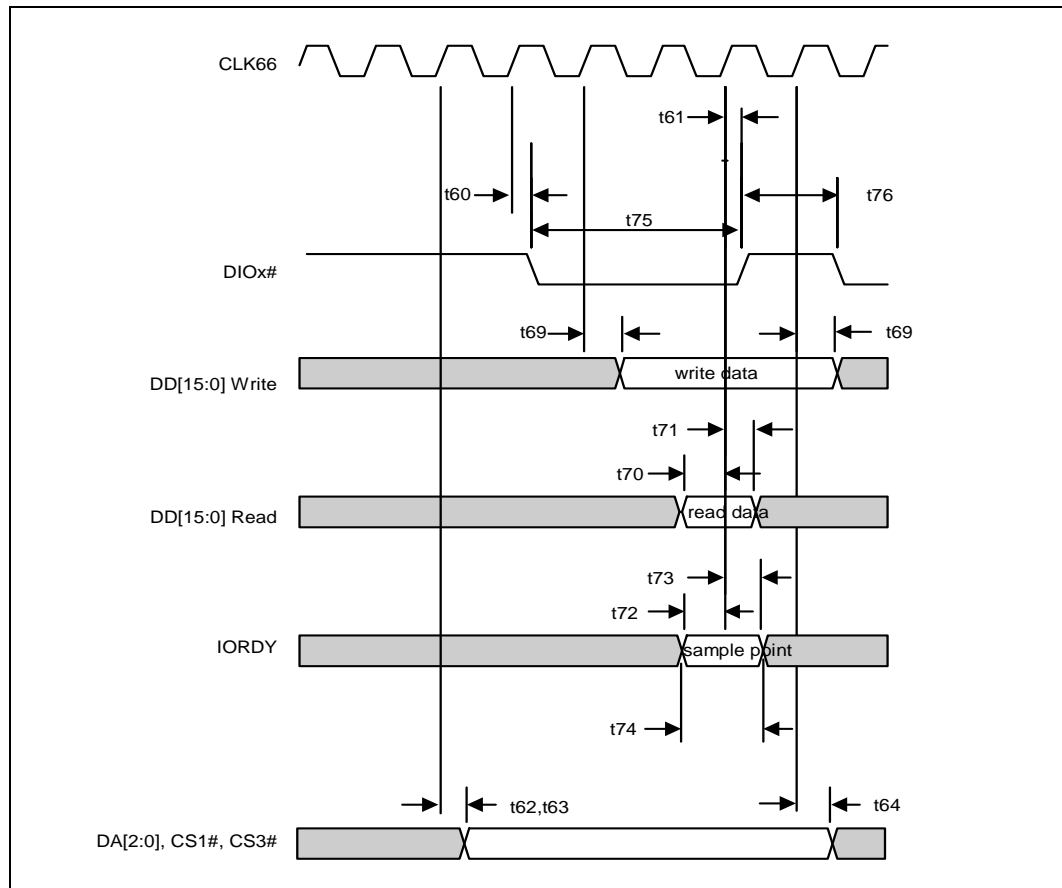

Figure 17-8. IDE Multiword DMA

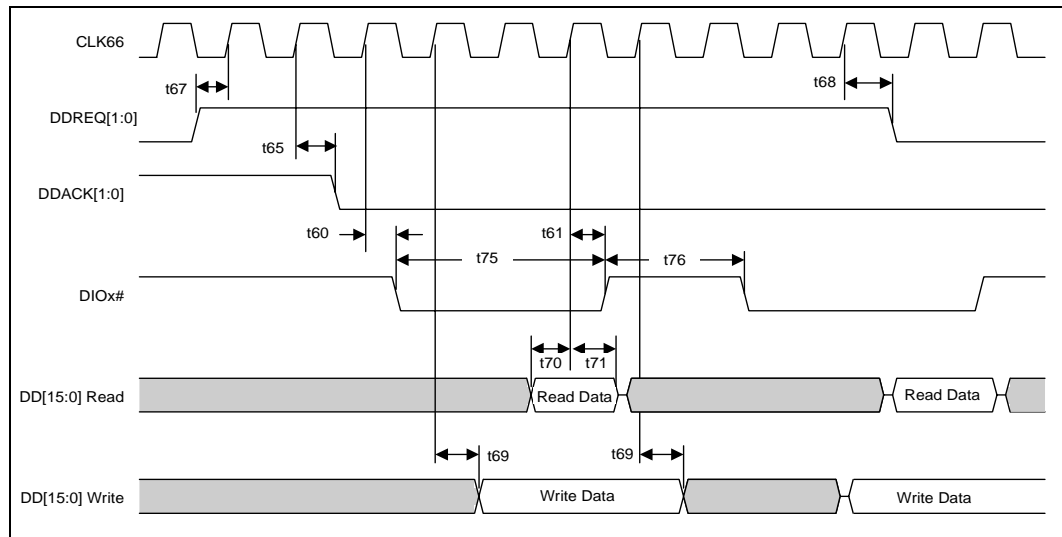

Figure 17-9. Ultra ATA Mode (Drive Initiating a Burst Read)

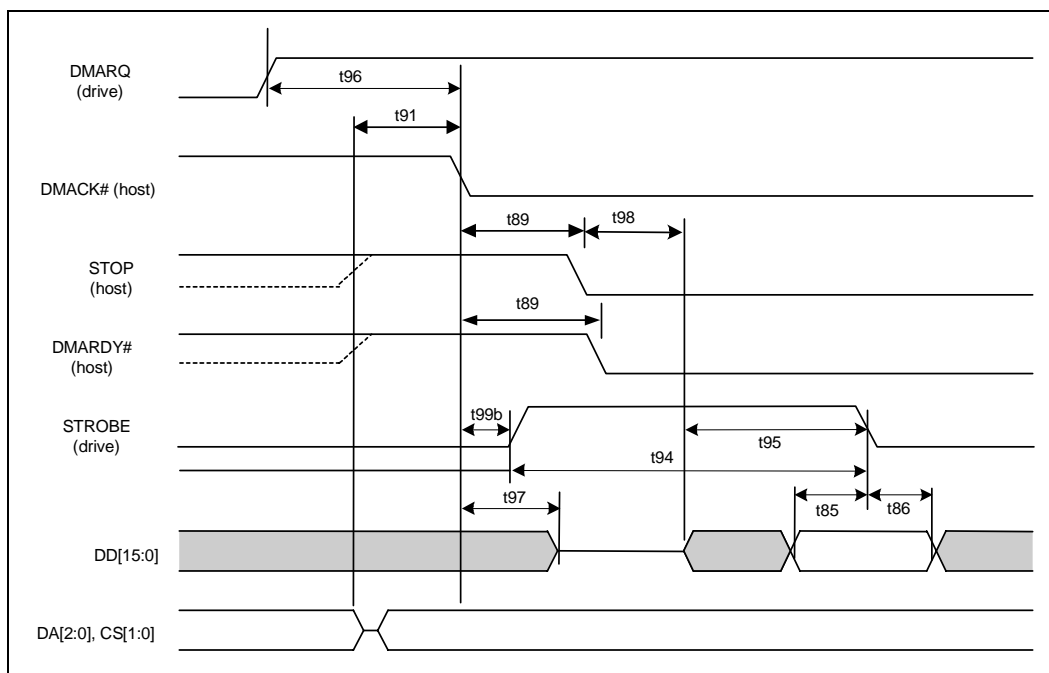

Figure 17-10. Ultra ATA Mode (Sustained Burst)

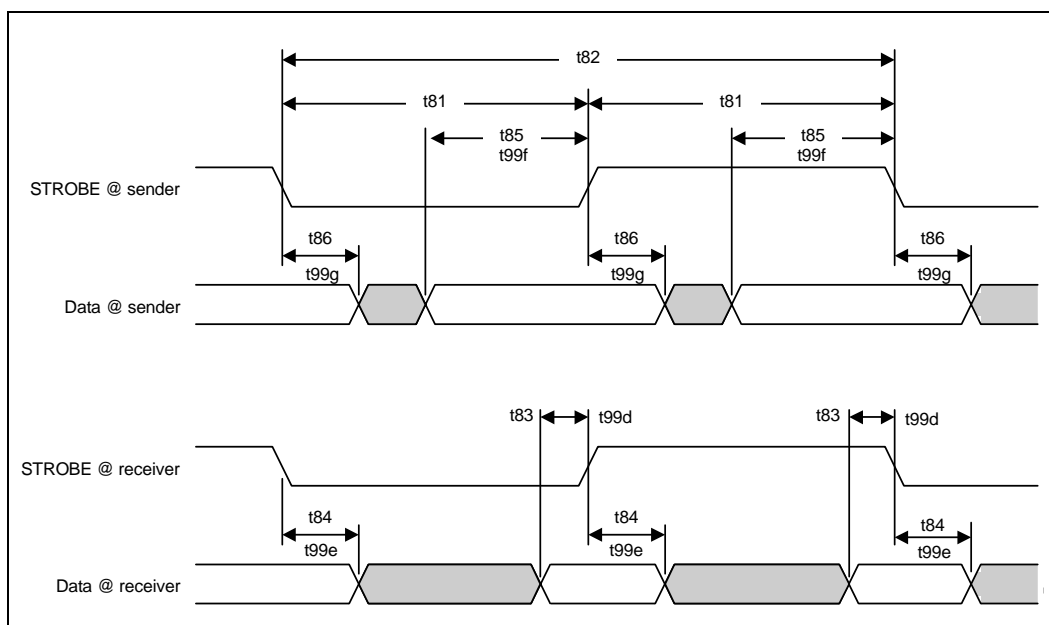

Figure 17-11. Ultra ATA Mode (Pausing a DMA Burst)

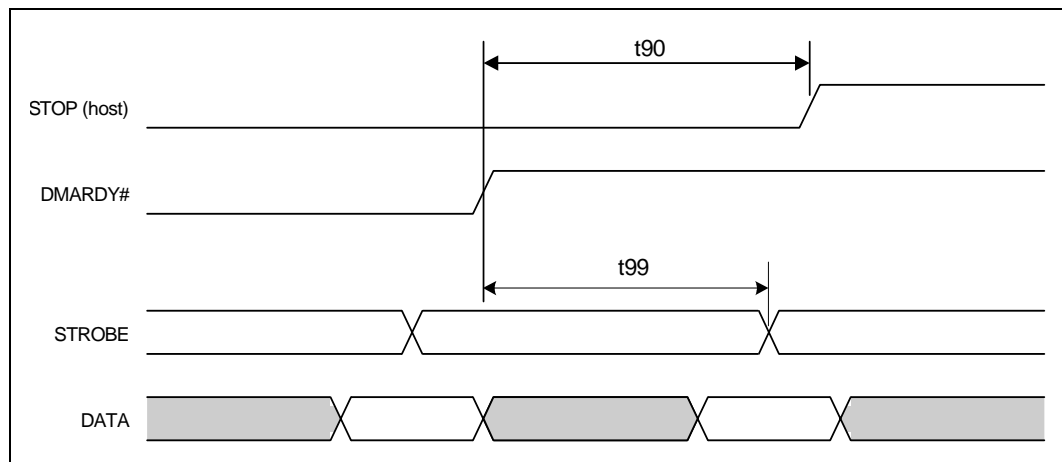

Figure 17-12. Ultra ATA Mode (Terminating a DMA Burst)

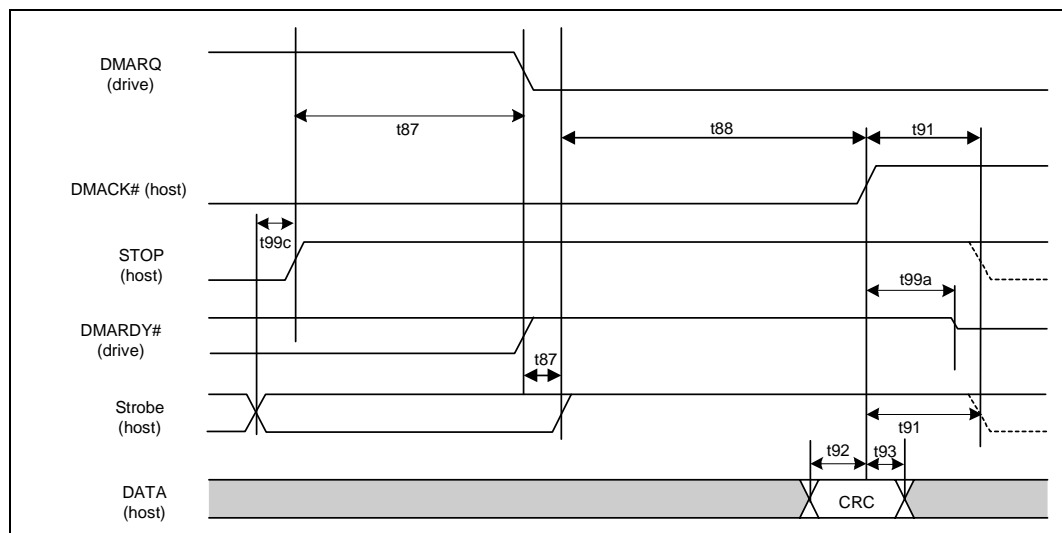

Figure 17-13. USB Rise and Fall Times

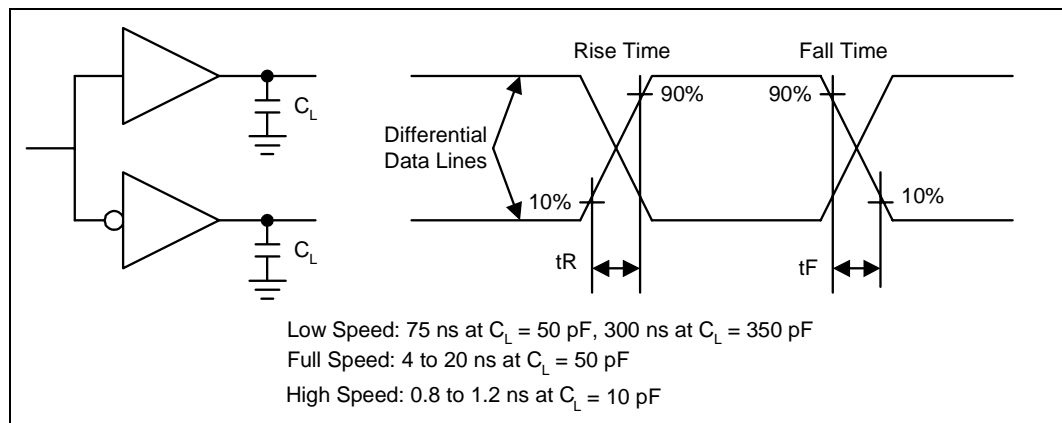

Figure 17-14. USB Jitter

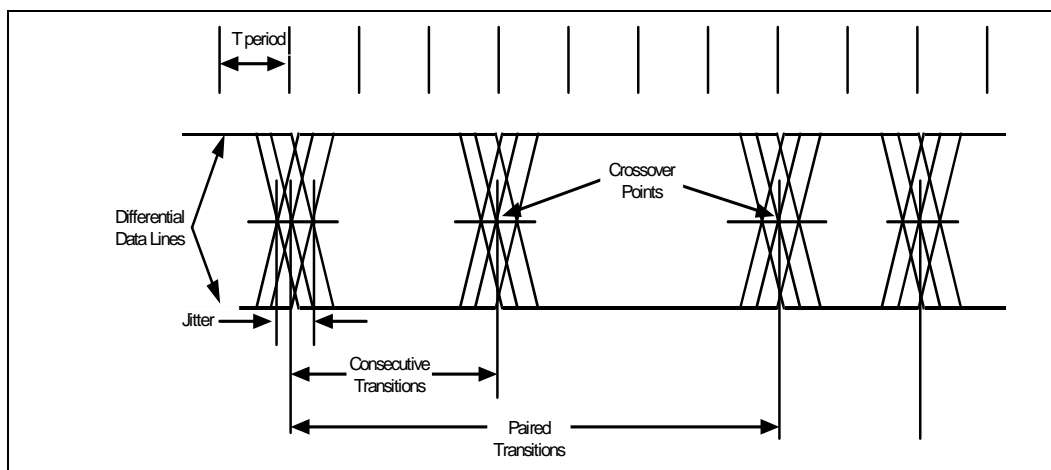

Figure 17-15. USB EOP Width

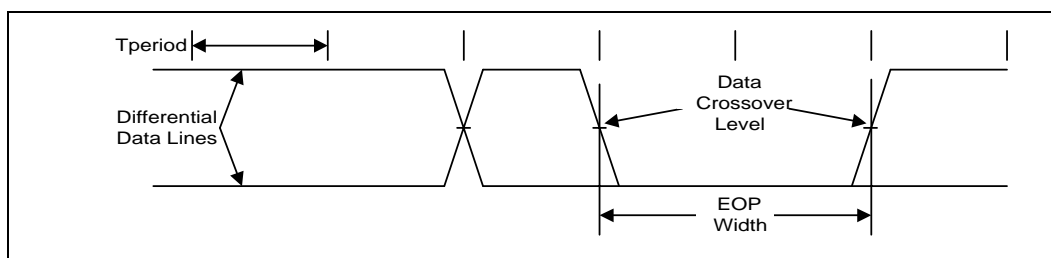

Figure 17-16. SMBus Transaction

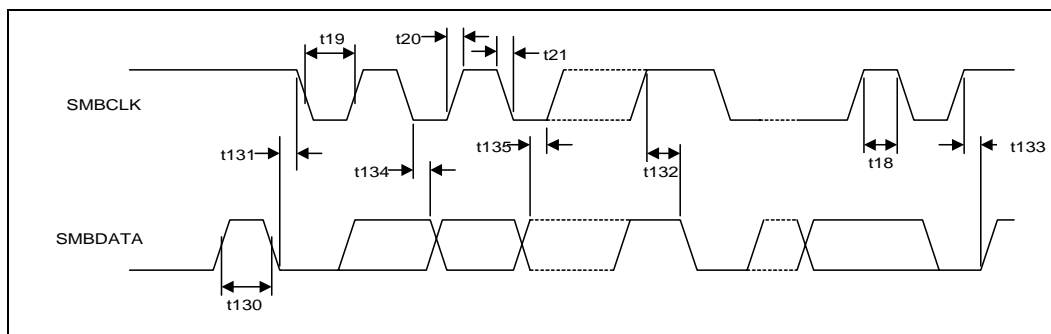

Figure 17-17. SMBus Timeout

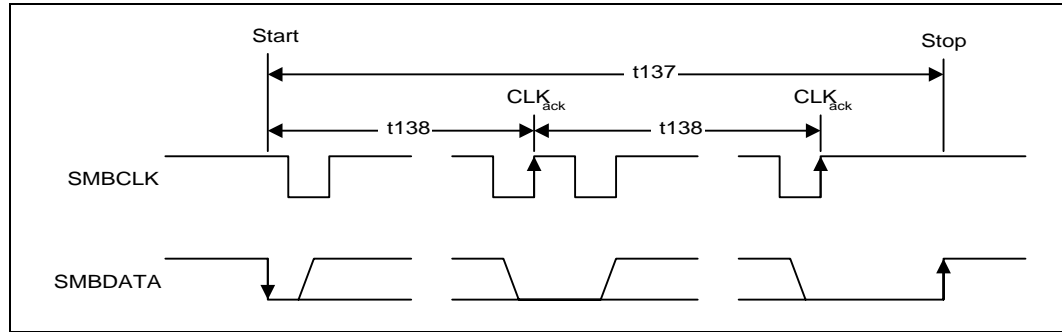

Figure 17-18. Power Sequencing and Reset Signal Timings

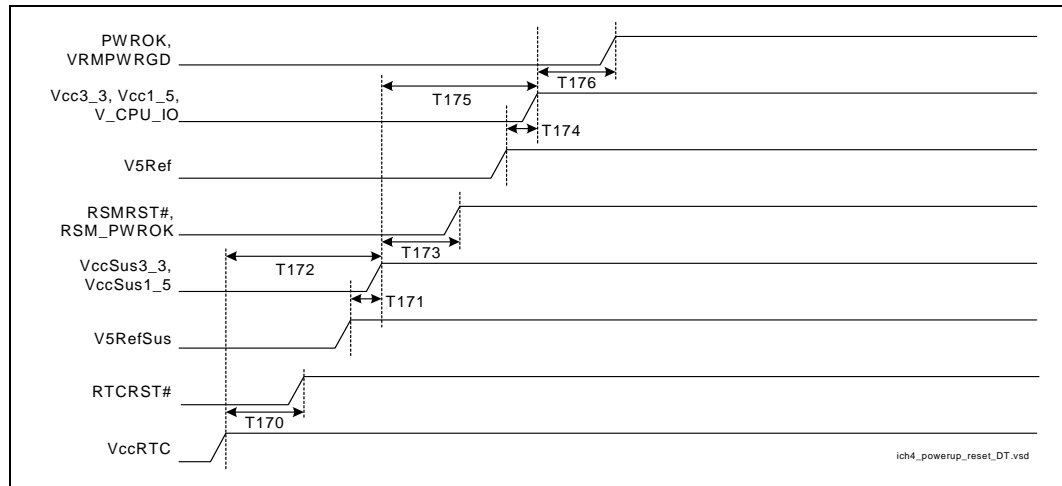

Figure 17-19. G3 (Mechanical Off) to S0 Timings

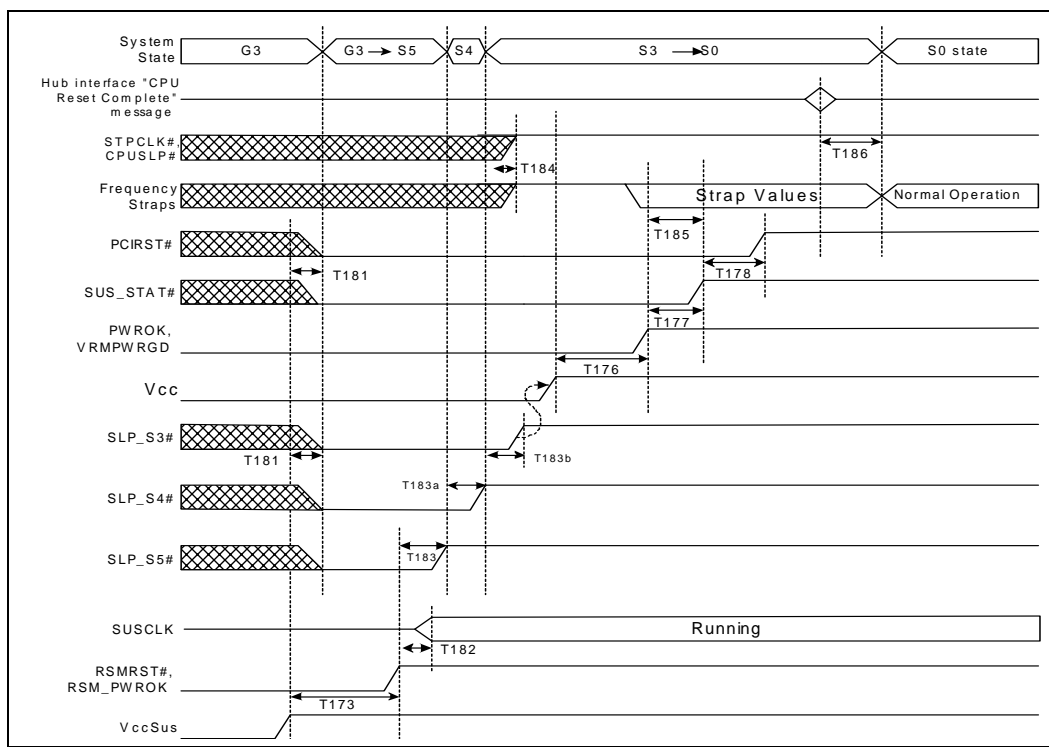

Figure 17-20. S0 to S1 to S0 Timing

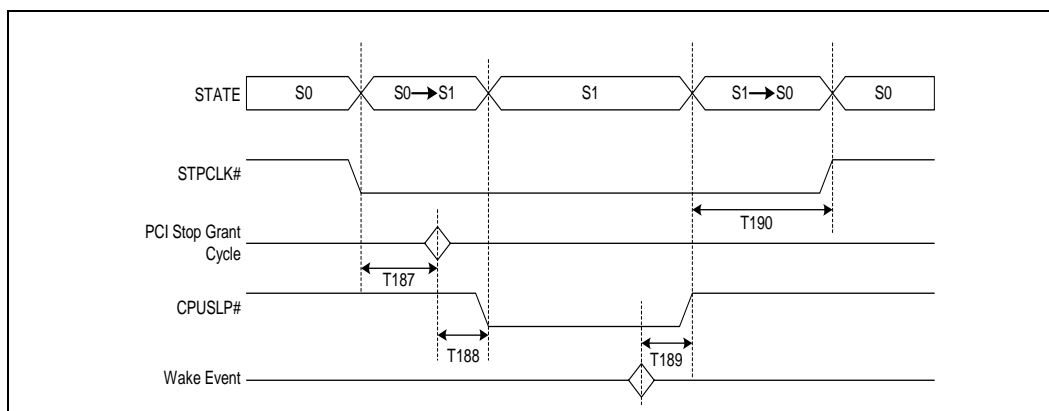

Figure 17-21. S0 to S5 to S0 Timings

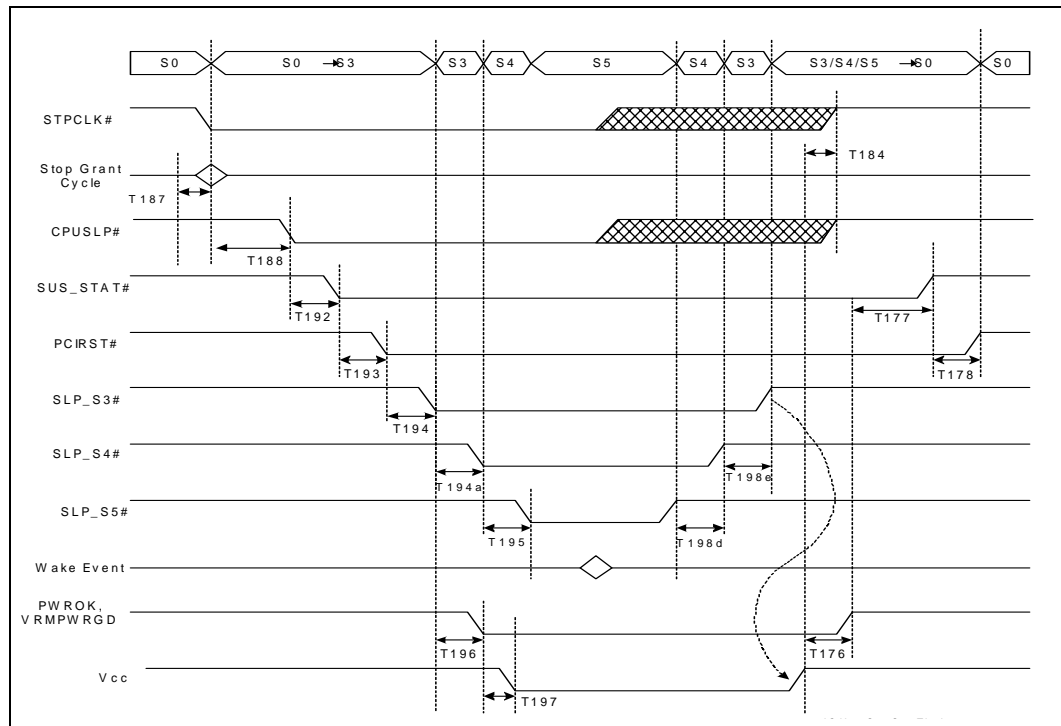

Figure 17-22. C0 to C2 to C0 Timings

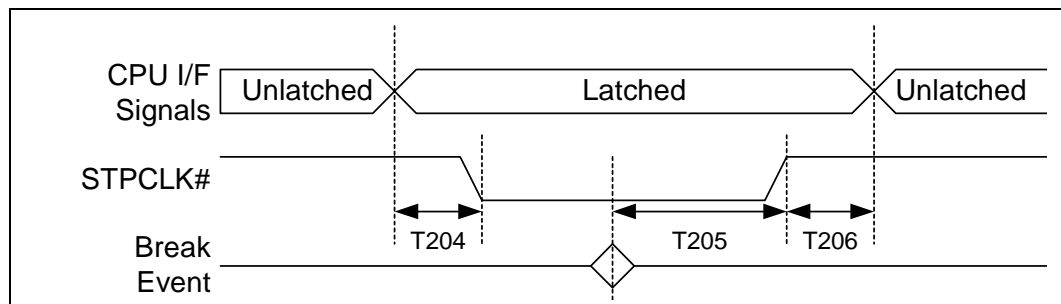
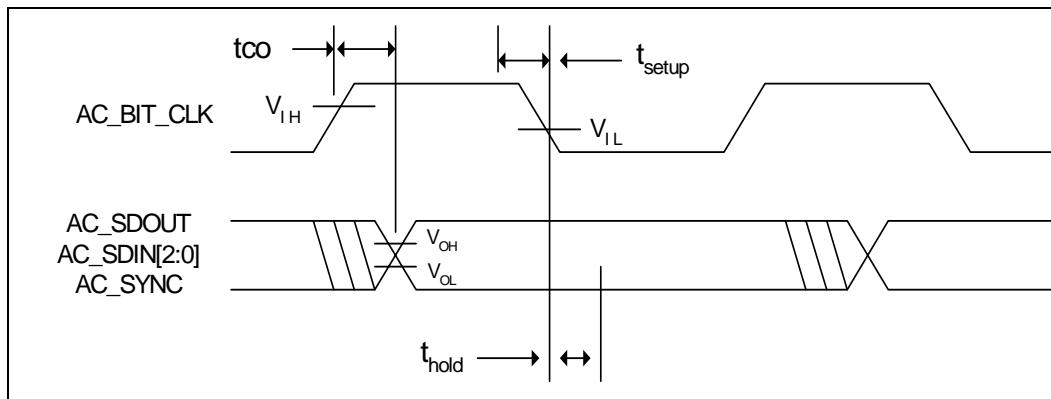

Figure 17-23. AC '97 Data Input and Output Timings



Package Information

18

Figure 18-1 and Figure 18-2 illustrate the ICH4 421 BGA package. All dimensions are in millimeters.

Figure 18-1. Intel® ICH4 Package (Top and Side Views)

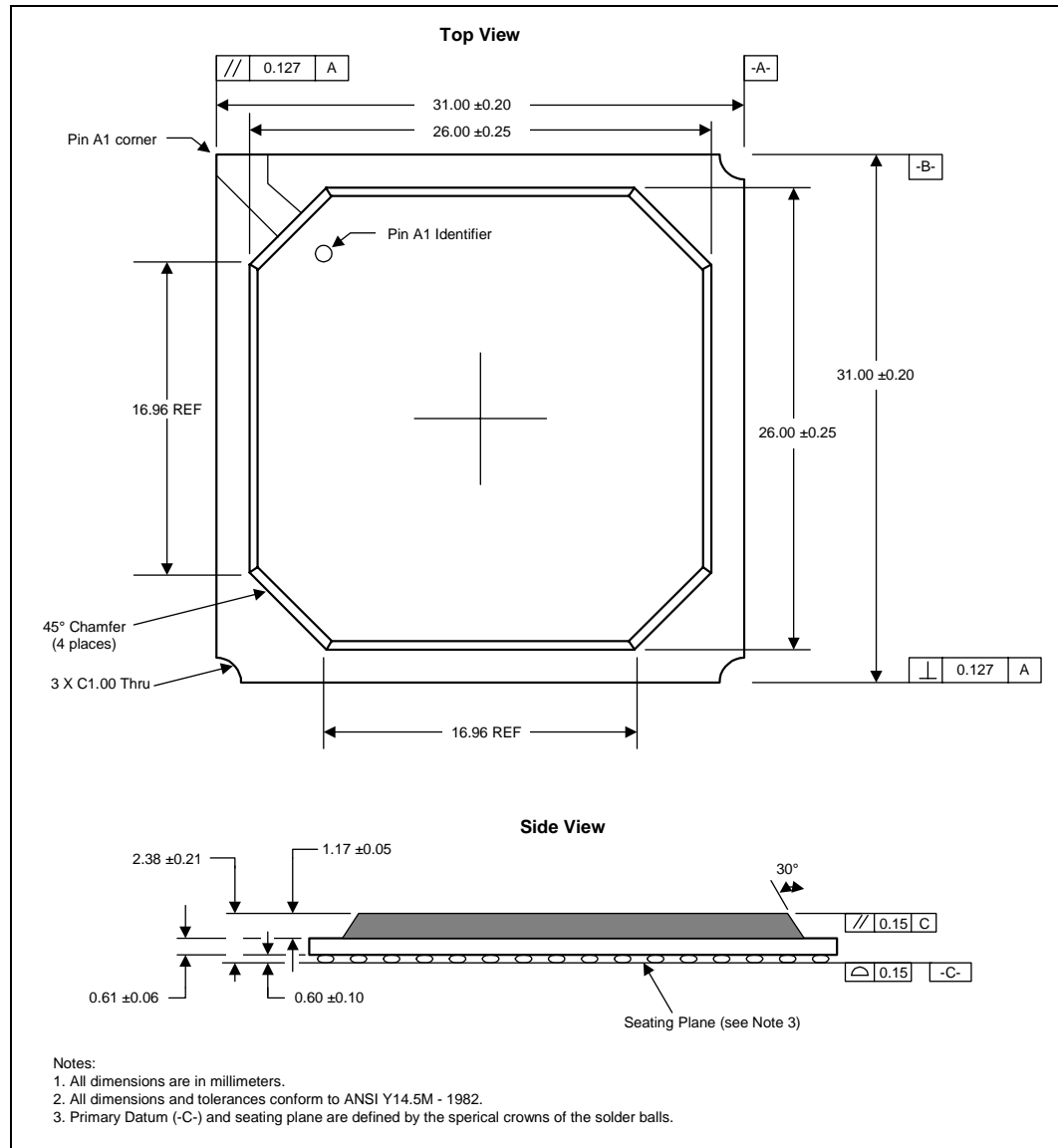
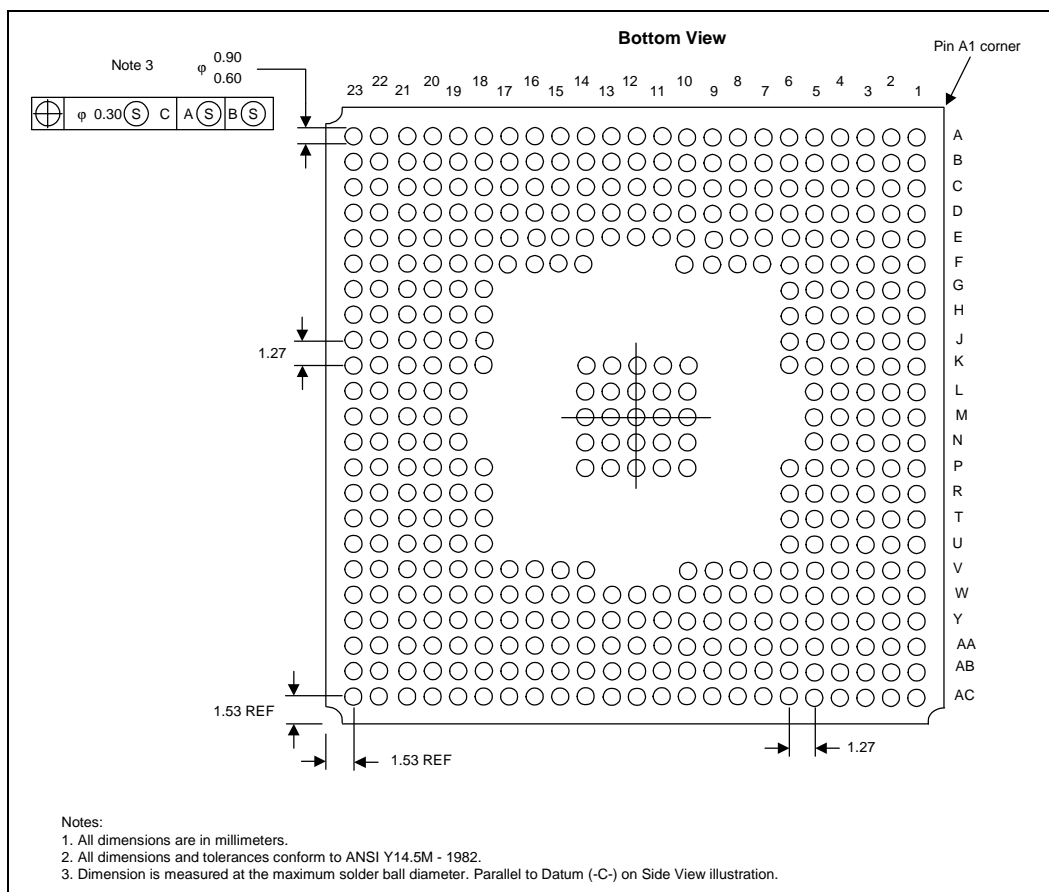

Figure 18-2. Intel® ICH4 Package (Bottom View)



Testability

19

19.1 Test Mode Description

The ICH4 supports two types of test modes, a tri-state test mode and a XOR Chain test mode. Driving RTCRST# low for a specific number of PCI clocks while PWROK is high will activate a particular test mode as described in Table 19-1.

Note: RTCRST# can be driven low any time after PCIRST# is inactive.

Table 19-1. Test Mode Selection

Number of PCI Clocks RTCRST# Driven Low After PWROK Active	Test Mode
<4	No Test Mode Selected
4	XOR Chain 1
5	XOR Chain 2
6	XOR Chain 3
7	XOR Chain 4
8	All "Z"
9–13	Reserved. DO NOT ATTEMPT
14	Long XOR
15–42	Reserved. DO NOT ATTEMPT
43–51	No Test Mode Selected
52	XOR Chain 6
53	XOR Chain 4 Bandgap
>53	No Test Mode Selected

Figure 19-1 illustrates the entry into a test mode. A particular test mode is entered on the rising edge of RTCRST# after being asserted for a specific number of PCI clocks while PWROK is active. To change test modes, the same sequence should be followed again. To restore the ICH4 to normal operation, execute the sequence with RTCRST# being asserted so that no test mode is selected as specified in Table 19-1.

Figure 19-1. Test Mode Entry (XOR Chain Example)

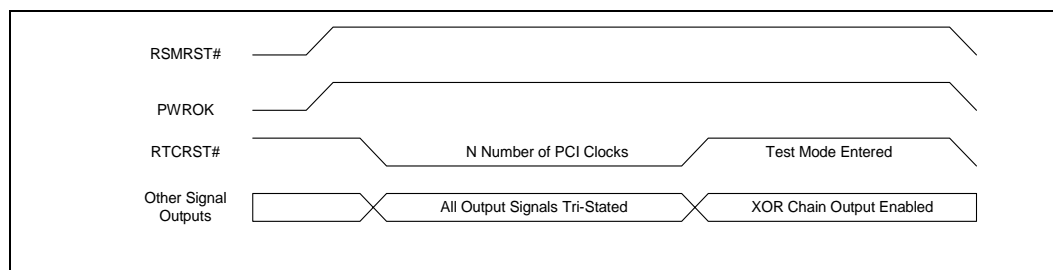

NOTE: After driving RTCRST# low, should wait 0.1 ms before clocking the testmode with PCICLK. It may take up to 2 PCICLKs after RTCRST# is brought high to enter the test mode.

19.2 Tri-State Mode

When in the tri-state mode, all outputs and bi-directional pin are tri-stated, including the XOR chain outputs.

19.3 XOR Chain Mode

In the ICH4, provisions for Automated Test Equipment (ATE) board level testing are implemented with XOR chains. The ICH4 signals are grouped into four independent XOR chains which are enabled individually. When an XOR chain is enabled, all output and bi-directional buffers within that chain are tri-stated, except for the XOR chain output. Every signal in the enabled XOR chain (except for the XOR chain's output) functions as an input. All output and bi-directional buffers for pins not in the selected XOR chain are tri-stated. Figure 19-2 is a schematic example of XOR chain circuitry.

Figure 19-2. Example XOR Chain Circuitry

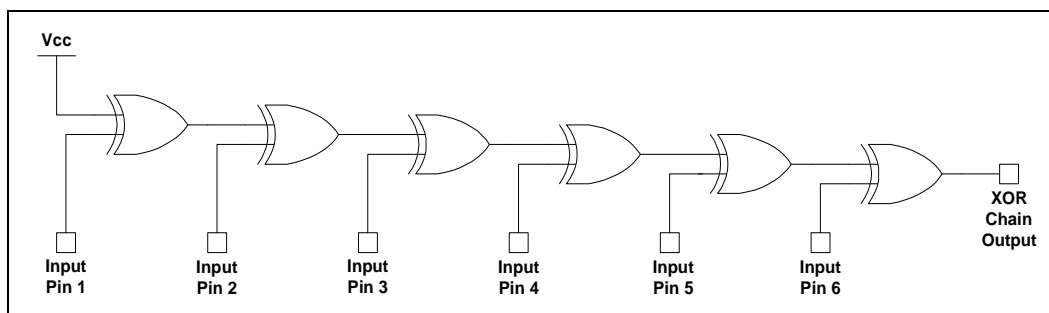

19.3.1 XOR Chain Testability Algorithm Example

XOR chain testing allows motherboard manufacturers to check component connectivity (e.g., opens and shorts to VCC or GND). An example algorithm to do this is shown in Table 19-2.

Table 19-2. XOR Test Pattern Example

Vector	Input Pin 1	Input Pin 2	Input Pin 3	Input Pin 4	Input Pin 5	Input Pin 6	XOR Output
1	0	0	0	0	0	0	1
2	1	0	0	0	0	0	0
3	1	1	0	0	0	0	1
4	1	1	1	0	0	0	0
5	1	1	1	1	0	0	1
6	1	1	1	1	1	0	0
7	1	1	1	1	1	1	1

In this example, Vector 1 applies all 0s to the chain inputs. The outputs being non-inverting, will consistently produce a 1 at the XOR output on a good board. One short to VCC (or open floating to VCC) will result in a 0 at the chain output, signaling a defect.

Likewise, applying Vector 7 (all 1s) to the chain inputs (given that there are an even number of input signals in the chain), will consistently produce a 1 at the XOR chain output on a good board. One short to VSS (or open floating to VSS) will result in a 0 at the chain output, signaling a defect. It is important to note that the number of inputs pulled to 1 will affect the expected chain output value. If the number of chain inputs pulled to 1 is even, then expect 1 at the output. If the number of chain inputs pulled to 1 is odd, expect 0 at the output.

Continuing with the example in Table 19-2, as the input pins are driven to 1 across the chain in sequence, the XOR Output will toggle between 0 and 1. Any break in the toggling sequence (e.g., 1011) will identify the location of the short or open.

Table 19-3. XOR Chain 1

Pin Name	Ball #	Notes
AC_SYNC	C9	Top of XOR Chain
AC_SDOOUT	D9	2nd signal in XOR
PIRQE#/GPIO2	C8	
GNT2#	A7	
GNT3#	B7	
GNTA#/GPIO16	E8	
REQB#/REQ5#/GPIO1	A6	
REQ4#	B6	
REQA#/GPIO0	B5	
PIRQF#/GPIO3	D7	
GNT4#	D6	
GNTB#/GNT5#/GPIO17	C5	
GNT1#	E6	
PIRQC#	B4	
PIRQA#	D5	
PIRQH#/GPIO5	C4	
PIRQD#	A3	
REQ1#	A2	
REQ2#	B3	
AD18	E5	
REQ0#	B1	
PIRQG#/GPIO4	C3	
AD28	D3	
PIRQB#	C2	
AD15	F5	

Pin Name	Ball #	Notes ⁽¹⁾
GNT0#	C1	
AD22	E4	
AD30	D2	
AD20	E3	
AD16	F4	
AD4	G5	
AD24	E2	
AD0	H5	
STOP#	F3	
AD11	G4	
AD26	E1	
AD6	H4	
TRDY#	F2	
FRAME#	F1	
AD9	G2	
AD2	H3	
PAR	G1	
AD5	J4	
AD13	H2	
AD1	J3	
SERR#	K5	
C/BE0#	J2	
C/BE1#	K4	
AD3	K1	
AD10	L1	
		XOR Chain 1
TP[0]	AB2	OUTPUT

NOTES:

1. RTCRST# asserted for 4 PCI clocks while PWROK active.

Table 19-4. XOR Chain 2

Pin Name	Ball #	Notes
AD8	K2	Top of XOR Chain
IRDY#	L5	2nd signal in XOR
PERR#	L4	
AD14	L3	
AD12	L2	
AD23	M5	
C/BE2#	M4	
DEVSEL#	M3	
PLOCK#	M2	
AD17	N1	
AD19	N2	
AD21	N3	
C/BE3#	N4	
AD25	P1	
AD27	P2	
AD29	R1	
AD31	P4	
GPIO6	R2	
PCICLK	P5	

Pin Name	Ball #	Notes ⁽¹⁾
GPIO7	R3	
LAD0/FWH0	T2	
LAD1/FWH1	R4	
GPIO21	T3	
LDRQ0#	U3	
LAD2/FWH2	T4	
LAD3/FWH3	U2	
LDRQ1#	U4	
LFRAME# / FWH4	T5	
THRM#	V1	
AC_BIT_CLK	B8	
REQ3#	C7	
AD7	J5	
GPIO8	V4	
RI#	Y1	
AC_SDIN0	D13	
AC_SDIN2	B13	
AC_SDIN1	A13	
		XOR Chain 2
TP[0]	AB2	OUTPUT

NOTES:

1. RTCRST# asserted for 5 PCI clocks while PWROK active.

Table 19-5. XOR Chain 3

Pin Name	Ball #	Notes	Pin Name	Ball #	Notes ⁽¹⁾
PDD10	AC9	Top of XOR Chain	INTR	AB22	
PDDREQ	AA11	2nd signal in XOR	NMI	V21	
PDD12	AB10		IGNNE#	W21	
PDD14	W11		INIT#	V22	
PDD1	AC11		STPCLK#	V23	
PDD15	Y11		SMI#	W23	
PDD0	AB11		CPUSLP#	U21	
PDIOR#	AC12		NC	U23	
PIORDY	AB12		HI_STB#/ HI_STBF	N20	
PDDACK#	Y12		HI_STB/ HI_STBS	P21	
PDIOW#	W12		GPIO23	J21	
IRQ14	AC13		GPIO32	J20	
PDA1	AB13		GPIO33	G22	
PDA0	AA13		GPIO37	H20	
PDCS1#	Y13		GPIO35	G20	
PDA2	W13		GPIO36	F21	
PDCS3#	AB14		GPIO34	F20	
IRQ15	AA19		PDD6	Y8	
GPIO19	W18		PDD4	AA7	
GPIO18	Y21		PDD7	AA8	
GPIO22	Y20		PDD11	W9	
GPIO20	W19		PDD5	AB8	
VRMPWRGD	V19		PDD8	AB9	
A20GATE	Y22		PDD9	Y9	
RCIN#	U22		PDD13	W10	
NC	V20		PDD2	Y10	
THRMTRIP#	W20		PDD3	AA10	
A20M#	AB23		INTRUDER#	W6	
CPUPWRGD	Y23		SLP_S5#	AA2	
					XOR Chain 3
			RI#	Y1	OUTPUT

NOTES:

1. RTCRST# asserted for 6 PCI clocks while PWROK active.

Table 19-6. XOR Chain 4-1

Pin Name	Ball #	Notes	Pin Name	Ball #	Notes ⁽¹⁾
SDD8	Y14	Top of XOR Chain	HI4	P19	
SDD3	AC16	2nd signal in XOR	HICOMP	R23	
SDD6	W14		HI_STB#/ HI_STBF	N20	
SDD10	AA15		HI_STB/ HI_STBS	P21	
SDD12	AB16		HI3	M21	
SDD11	Y15		HI2	M19	
SDD1	AB17		HI1	L20	
SDD4	W15		HI0	L19	
SDD13	Y16		HI10	N22	
SDDREQ	AB18		HI8	P23	
SDD14	AA17		HI9	L22	
SDDACK#	AB19		HI11	K21	
SIORDY	AC19		APICD1	K20	
SDA1	AC20		SERIRQ	J22	
SDD15	Y17		APICCLK	J19	
SDD2	W16		APICD0	H19	
SDA2	AC21		CLK14	J23	
SDIOW#	AA18		SPKR	H23	
SDD0	W17		GPIO41	H21	
SDCS1#	AB21		GPIO39	H22	
SDIOR#	Y18		GPIO40	G23	
SDCS3#	AC22		GPIO38	F23	
SDA0	AA20		GPIO42	F22	
FERR#	AA21		GPIO43	E23	
CLK66	T21		SDD7	AA14	
HI6	T20		SDD9	AC15	
HI5	R19		SDD5	AB15	
HI7	R20		SLP_S4#	Y2	
					XOR Chain 4-1
			GPIO8	V4	OUTPUT

NOTES:

1. RTCRST# asserted for 7 PCI clocks while PWROK active.

Table 19-7. XOR Chain 4-2

Pin Name	Ball #	Notes
PME#	W2	Top of XOR Chain
GPIO25	V2	2nd signal in XOR
GPIO12	V5	
GPIO27	W1	
PCIRST#	U5	
GPIO13	W3	
GPIO28	W4	
PWRBTN#	AA1	
SYS_RESET#	Y3	
SMLINK1	AB1	
TP[0]	AB2	
GPIO24	AC2	
SUSCLK	AA4	
SUS_STAT#/ LPCPD#	AB3	
SMLINK0	AC3	
SLP_S3#	Y4	
SMBDATA	AB4	
SMBCLK	AC4	
SMBALERT#/ GPIO11	AA5	
CLK48	F19	
OC0#	B15	
OC2#	A15	
OC5#	D14	
OC1#	C14	
OC3#	B14	
OC4#	A14	

Pin Name	Ball #	Notes ⁽¹⁾
AC_RST#	C13	
USBP0P	C20	
USBP0N	D20	
USBP1P	A21	
USBP1N	B21	
USBP2P	C18	
USBP2N	D18	
USBP3P	A19	
USBP3N	B19	
USBP4P	C16	
USBP4N	D16	
USBP5P	A17	
USBP5N	B17	
LAN_TXD2	A12	
LAN_CLK	C11	
EE_DIN	D11	
LAN_RXD2	A11	
LAN_RSTSYNC	B11	
EE_CS	D10	
LAN_TXD0	B10	
LAN_RXD0	A10	
LAN_TXD1	C10	
EE_DOUT	A8	
LAN_RXD1	A9	
EE_SHCLK	C12	
		XOR Chain 4-2
AC_SDIN1	A13	OUTPUT

NOTES:

1. RTCRST# asserted for 7 PCI clocks while PWROK active.

Table 19-8. XOR Chain 6

Pin Name	Ball #	Notes ⁽¹⁾
RTCX1	AC7	Top of XOR Chain

Pin Name	Ball #	Notes ⁽¹⁾
		XOR Chain 6
TP[0]	AB2	OUTPUT

NOTES:

1. RTCRST# asserted for 52 PCI clocks while PWROK active.

Table 19-9. LONG XOR Chain (Sheet 1 of 3)

Pin Name	Ball #	Notes ⁽¹⁾
AC_SYNC	C9	Top of XOR Chain
AC_SDOOUT	D9	2nd signal in XOR
PIRQE#/GPIO2	C8	
GNT2#	A7	
GNT3#	B7	
GNTA#/GPIO16	E8	
REQB#/REQ5#/ GPIO1	A6	
REQ4#	B6	
REQA#/GPIO0	B5	
PIRQF#/GPIO3	D7	
GNT4#	D6	
GNTB#/ GNT5#GPIO17	C5	
GNT1#	E6	
PIRQC#	B4	
PIRQA#	D5	
PIRQH#/GPIO5	C4	
PIRQD#	A3	
REQ1#	A2	
REQ2#	B3	
AD18	E5	
REQ0#	B1	
PIRQG#/GPIO4	C3	
AD28	D3	
PIRQB#	C2	
AD15	F5	
GNT0#	C1	
AD22	E4	
AD30	D2	
AD20	E3	
AD16	F4	
AD4	G5	
AD24	E2	
AD0	H5	
STOP#	F3	
AD11	G4	

Pin Name	Ball #	Notes ⁽¹⁾
PDA0	AA13	
PDCS1#	Y13	
PDA2	W13	
PDCS3#	AB14	
IRQ15	AA19	
GPIO19	W18	
GPIO18	Y21	
GPIO22	Y20	
GPIO20	W19	
VRMPWRGD	V19	
A20GATE	Y22	
RCIN#	U22	
NC	V20	
THRMTRIP#	W20	
A20M#	AB23	
CPUPWRGD	Y23	
INTR	AB22	
NMI	V21	
IGNNE#	W21	
INIT#	V22	
STPCLK#	V23	
SMI#	W23	
CPUSLP#	U21	
NC	U23	
HI_STB#/ HI_STBF	N20	
HI_STB/ HI_STBS	P21	
GPIO23	J21	
GPIO32	J20	
GPIO33	G22	
GPIO37	H20	
GPIO35	G20	
GPIO36	F21	
GPIO34	F20	
PDD6	Y8	
PDD4	AA7	

Table 19-9. LONG XOR Chain (Sheet 2 of 3)

Pin Name	Ball #	Notes ⁽¹⁾
AD26	E1	
AD6	H4	
TRDY#	F2	
FRAME#	F1	
AD9	G2	
AD2	H3	
PAR	G1	
AD5	J4	
AD13	H2	
AD1	J3	
SERR#	K5	
C/BE0#	J2	
C/BE1#	K4	
AD3	K1	
AD10	L1	
AD8	K2	
IRDY#	L5	
PERR#	L4	
AD14	L3	
AD12	L2	
AD23	M5	
C/BE2#	M4	
DEVSEL#	M3	
PLOCK#	M2	
AD17	N1	
AD19	N2	
AD21	N3	
C/BE3#	N4	
AD25	P1	
AD27	P2	
AD29	R1	
AD31	P4	
GPIO6	R2	
PCICLK	P5	
GPIO7	R3	
LAD0/FWH0	T2	

Pin Name	Ball #	Notes ⁽¹⁾
PDD7	AA8	
PDD11	W9	
PDD5	AB8	
PDD8	AB9	
PDD9	Y9	
PDD13	W10	
PDD2	Y10	
PDD3	AA10	
PME#	W2	
GPIO25	V2	
GPIO12	V5	
GPIO27	W1	
PCIRST#	U5	
GPIO13	W3	
GPIO28	W4	
PWRBTN#	AA1	
SYS_RESET#	Y3	
SMLINK1	AB1	
TP[0]	AB2	
GPIO24	AC2	
SUSCLK	AA4	
SUS_STAT#/ LPCPD#	AB3	
SMLINK0	AC3	
SLP_S3#	Y4	
SMBDATA	AB4	
SMBCLK	AC4	
SMBALERT#/ GPIO11	AA5	
CLK48	F19	
OC0#	B15	
OC2#	A15	
OC5#	D14	
OC1#	C14	
OC3#	B14	
OC4#	A14	
AC_RST#	C13	
USBP0P	C20	

Table 19-9. LONG XOR Chain (Sheet 3 of 3)

Pin Name	Ball #	Notes ⁽¹⁾
LAD1/FWH1	R4	
GPIO21	T3	
LDRQ0#	U3	
LAD2/FWH2	T4	
LAD3/FWH3	U2	
LDRQ1#	U4	
LFRAME# / FWH4	T5	
THRM#	V1	
AC_BIT_CLK	B8	
REQ3#	C7	
AD7	J5	
PDD10	AC9	
PDDREQ	AA11	
PDD12	AB10	
PDD14	W11	
PDD1	AC11	
PDD15	Y11	
PDD0	AB11	
PDIOR#	AC12	
PIORDY	AB12	
PDDACK#	Y12	
PDIOW#	W12	
IRQ14	AC13	
PDA1	AB13	

Pin Name	Ball #	Notes ⁽¹⁾
USBP0N	D20	
USBP1P	A21	
USBP1N	B21	
USBP2P	C18	
USBP2N	D18	
USBP3P	A19	
USBP3N	B19	
USBP4P	C16	
USBP4N	D16	
USBP5P	A17	
USBP5N	B17	
LAN_TXD2	A12	
LAN_CLK	C11	
EE_DIN	D11	
LAN_RXD2	A11	
LAN_RSTSYNC	B11	
EE_CS	D10	
LAN_TXD0	B10	
LAN_RXD0	A10	
LAN_TXD1	C10	
EE_DOUT	A8	
LAN_RXD1	A9	
EE_SHCLK	C12	
		LONG XOR Chain
FERR#	AA21	OUTPUT

NOTES:

1. RTCRST# asserted for 14 PCI Clocks while PWROK active.

Register Index

A

Table A-1. Intel® ICH4 PCI Configuration Registers (Sheet 1 of 10)

Register Name	Offset	Datasheet Location
LAN Controller (B1:D8:F0)		
Vendor Identification	00–01h	Section 7.1.1.1, “VID—Vendor ID Register (LAN Controller—B1:D8:F0)” on page 7-252
Device Identification	02–03h	Section 7.1.1.2, “DID—Device ID Register (LAN Controller—B1:D8:F0)” on page 7-252
PCI Command	04–05h	Section 7.1.1.3, “PCICMD—PCI Command Register (LAN Controller—B1:D8:F0)” on page 7-253
PCI Device Status	06–07h	Section 7.1.1.4, “PCISTS—PCI Status Register (LAN Controller—B1:D8:F0)” on page 7-254
Revision Identification	08h	Section 7.1.1.5, “REVID—Revision ID Register (LAN Controller—B1:D8:F0)” on page 7-255
Sub Class Code	0Ah	Section 7.1.1.6, “SCC—Sub-Class Code Register (LAN Controller—B1:D8:F0)” on page 7-255
Base Class Code	0Bh	Section 7.1.1.7, “BCC—Base-Class Code Register (LAN Controller—B1:D8:F0)” on page 7-255
Cache Line Size	0Ch	Section 7.1.1.8, “CLS—Cache Line Size Register (LAN Controller—B1:D8:F0)” on page 7-255
Master Latency Timer	0Dh	Section 7.1.1.9, “PMLT—PCI Master Latency Timer Register (LAN Controller—B1:D8:F0)” on page 7-256
Header Type	0Eh	Section 7.1.1.10, “HEADTYP—Header Type Register (LAN Controller—B1:D8:F0)” on page 7-256
CSR Memory-Mapped Base Address	10–13h	Section 7.1.1.11, “CSR_MEM_BASE CSR — Memory-Mapped Base Address Register (LAN Controller—B1:D8:F0)” on page 7-256
CSR I/O-Mapped Base Address	14–17h	Section 7.1.1.12, “CSR_IO_BASE — CSR I/O-Mapped Base Address Register (LAN Controller—B1:D8:F0)” on page 7-257
Subsystem Vendor ID	2C–2Dh	Section 7.1.1.13, “SVID — Subsystem Vendor ID (LAN Controller—B1:D8:F0)” on page 7-257
Subsystem ID	2E–2Fh	Section 7.1.1.14, “SID — Subsystem ID (LAN Controller—B1:D8:F0)” on page 7-257
Capabilities Pointer	34h	Section 7.1.1.15, “CAP_PTR — Capabilities Pointer (LAN Controller—B1:D8:F0)” on page 7-258
Interrupt Line Register	3Ch	Section 7.1.1.16, “INT_LN — Interrupt Line Register (LAN Controller—B1:D8:F0)” on page 7-258
Interrupt Pin Register	3Dh	Section 7.1.1.17, “INT_PN — Interrupt Pin Register (LAN Controller—B1:D8:F0)” on page 7-258
Minimum Grant Register	3Eh	Section 7.1.1.18, “MIN_GNT — Minimum Grant Register (LAN Controller—B1:D8:F0)” on page 7-258
Maximum Latency Register	3Fh	Section 7.1.1.19, “MAX_LAT — Maximum Latency Register (LAN Controller—B1:D8:F0)” on page 7-259

Table A-1. Intel® ICH4 PCI Configuration Registers (Sheet 2 of 10)

Register Name	Offset	Datasheet Location
Capability ID Register	DCh	Section 7.1.20, "CAP_ID — Capability ID Register (LAN Controller—B1:D8:F0)" on page 7-259
Next Item Pointer	DDh	Section 7.1.21, "NXT_PTR — Next Item Pointer (LAN Controller—B1:D8:F0)" on page 7-259
Power Management Capabilities	DE–DFh	Section 7.1.22, "PM_CAP — Power Management Capabilities (LAN Controller—B1:D8:F0)" on page 7-260
Power Management Control/Status Register	E0–E1h	Section 7.1.23, "PMCSR — Power Management Control/Status Register (LAN Controller—B1:D8:F0)" on page 7-260
Data Register	E2h	Section 7.1.24, "PCIDATA — PCI Power Management Data Register (LAN Controller—B1:D8:F0)" on page 7-261
Hub Interface to PCI Bridge D30:F0		
Vendor ID	00–01h	Section 8.1.1, "VID—Vendor ID Register (HUB-PCI—D30:F0)" on page 8-276
Device ID	02–03h	Section 8.1.2, "DID—Device ID Register (HUB-PCI—D30:F0)" on page 8-276
PCI Device Command Register	04–05h	Section 8.1.3, "CMD—Command Register (HUB-PCI—D30:F0)" on page 8-277
PCI Device Status Register	06–07h	Section 8.1.4, "PD_STS—Primary Device Status Register (HUB-PCI—D30:F0)" on page 8-278
Revision ID	08h	Section 8.1.5, "RID—Revision Identification Register (HUB-PCI—D30:F0)" on page 8-279
Sub Class Code	0Ah	Section 8.1.6, "SCC—Sub-Class Code Register (HUB-PCI—D30:F0)" on page 8-279
Base Class Code	0Bh	Section 8.1.7, "BCC—Base-Class Code Register (HUB-PCI—D30:F0)" on page 8-279
Primary Master Latency Timer	0Dh	Section 8.1.8, "PMLT—Primary Master Latency Timer Register (HUB-PCI—D30:F0)" on page 8-279
Header Type	0Eh	Section 8.1.9, "HEADTYP—Header Type Register (HUB-PCI—D30:F0)" on page 8-280
Primary Bus Number	18h	Section 8.1.10, "PBUS_NUM—Primary Bus Number Register (HUB-PCI—D30:F0)" on page 8-280
Secondary Bus Number	19h	Section 8.1.11, "SBUS_NUM—Secondary Bus Number Register (HUB-PCI—D30:F0)" on page 8-280
Subordinate Bus Number	1Ah	Section 8.1.12, "SUB_BUS_NUM—Subordinate Bus Number Register (HUB-PCI—D30:F0)" on page 8-280
Secondary Master Latency Timer	1Bh	Section 8.1.13, "SMLT—Secondary Master Latency Timer Register (HUB-PCI—D30:F0)" on page 8-281
IO Base Register	1Ch	Section 8.1.14, "IOBASE—I/O Base Register (HUB-PCI—D30:F0)" on page 8-281
IO Limit Register	1Dh	Section 8.1.15, "IOLIM—I/O Limit Register (HUB-PCI—D30:F0)" on page 8-281
Secondary Status Register	1E–1Fh	Section 8.1.16, "SECSTS—Secondary Status Register (HUB-PCI—D30:F0)" on page 8-282
Memory Base	20–21h	Section 8.1.17, "MEMBASE—Memory Base Register (HUB-PCI—D30:F0)" on page 8-283
Memory Limit	22–23h	Section 8.1.18, "MEMLIM—Memory Limit Register (HUB-PCI—D30:F0)" on page 8-283

Table A-1. Intel® ICH4 PCI Configuration Registers (Sheet 3 of 10)

Register Name	Offset	Datasheet Location
Prefetchable Memory Base	24–25h	Section 8.1.19, "PREF_MEM_BASE—Prefetchable Memory Base Register (HUB-PCI—D30:F0)" on page 8-283
Prefetchable Memory Limit	26–27h	Section 8.1.20, "PREF_MEM_MLT—Prefetchable Memory Limit Register (HUB-PCI—D30:F0)" on page 8-284
I/O Base Upper 16 Bits	30–31h	Section 8.1.21, "IOBASE_HI—I/O Base Upper 16 Bits Register (HUB-PCI—D30:F0)" on page 8-284
I/O Limit Upper 16 Bits	32–33h	Section 8.1.22, "IOLIM_HI—I/O Limit Upper 16 Bits Register (HUB-PCI—D30:F0)" on page 8-284
Interrupt Line	3Ch	Section 8.1.23, "INT_LINE—Interrupt Line Register (HUB-PCI—D30:F0)" on page 8-284
Bridge Control	3E–3Fh	Section 8.1.24, "BRIDGE_CNT—Bridge Control Register (HUB-PCI—D30:F0)" on page 8-285
Hub Interface 1 Command Control Register	40–43h	Section 8.1.25, "HI1_CMD—Hub Interface 1 Command Control Register (HUB-PCI—D30:F0)" on page 8-286
Secondary PCI Device Hiding Register	44–45h	Section 8.1.26, "DEVICE_HIDE—Secondary PCI Device Hiding Register (HUB-PCI—D30:F0)" on page 8-287
ICH4 Configuration Register	50–51h	Section 8.1.27, "CNF—ICH4 Configuration Register (HUB-PCI—D30:F0)" on page 8-288
Multi-Transaction Timer	70h	Section 8.1.28, "MTT—Multi-Transaction Timer Register (HUB-PCI—D30:F0)" on page 8-288
PCI Master Status	82h	Section 8.1.29, "PCI_MAST_STS—PCI Master Status Register (HUB-PCI—D30:F0)" on page 8-289
Error Command Register	90h	Section 8.1.30, "ERR_CMD—Error Command Register (HUB-PCI—D30:F0)" on page 8-289
Error Status Register	92h	Section 8.1.31, "ERR_STS—Error Status Register (HUB-PCI—D30:F0)" on page 8-290
LPC Bridge D31:F0		
Vendor ID	00–01h	Section 9.1.1, "VID—Vendor ID Register (LPC I/F—D31:F0)" on page 9-292
Device ID	02–03h	Section 9.1.2, "DID—Device ID Register (LPC I/F—D31:F0)" on page 9-292
PCI Command Register	04–05h	Section 9.1.3, "PCICMD—PCI COMMAND Register (LPC I/F—D31:F0)" on page 9-293
PCI Device Status Register	06–07h	Section 9.1.4, "PCISTA—PCI Device Status (LPC I/F—D31:F0)" on page 9-294
Revision ID	08h	Section 9.1.5, "REVID—Revision ID Register (LPC I/F—D31:F0)" on page 9-294
Programming Interface	09h	Section 9.1.6, "PI—Programming Interface (LPC I/F—D31:F0)" on page 9-295
Sub Class Code	0Ah	Section 9.1.7, "SCC—Sub-Class Code Register (LPC I/F—D31:F0)" on page 9-295
Base Class Code	0Bh	Section 9.1.8, "BCC—Base-Class Code Register (LPC I/F—D31:F0)" on page 9-295
Header Type	0Eh	Section 9.1.9, "HEADTYP—Header Type Register (LPC I/F—D31:F0)" on page 9-295
ACPI Base Address Register	40–43h	Section 9.1.10, "PMBASE—ACPI Base Address (LPC I/F—D31:F0)" on page 9-296

Table A-1. Intel® ICH4 PCI Configuration Registers (Sheet 4 of 10)

Register Name	Offset	Datasheet Location
ACPI Control	44h	Section 9.1.11, "ACPI_CNTL—ACPI Control (LPC I/F — D31:F0)" on page 9-296
BIOS Control Register	4E–4Fh	Section 9.1.12, "BIOS_CNTL—BIOS Control Register (LPC I/F—D31:F0)" on page 9-297
TCO Control	54h	Section 9.1.13, "TCO_CNTL — TCO Control (LPC I/F — D31:F0)" on page 9-297
GPIO Base Address Register	58–5Bh	Section 9.1.14, "GPIOBASE—GPIO Base Address (LPC I/F—D31:F0)" on page 9-298
GPIO Control Register	5Ch	Section 9.1.15, "GPIO_CNTL—GPIO Control (LPC I/F—D31:F0)" on page 9-298
PIRQ[A:D] Routing Control	60–63h	Section 9.1.16, "PIRQ[n]_ROUT—PIRQ[A,B,C,D] Routing Control (LPC I/F—D31:F0)" on page 9-298
Serial IRQ Control Register	64h	Section 9.1.17, "SERIRQ_CNTL—Serial IRQ Control (LPC I/F—D31:F0)" on page 9-299
PIRQ[E:H] Routing Control	68–6Bh	Section 9.1.18, "PIRQ[n]_ROUT—PIRQ[E,F,G,H] Routing Control (LPC I/F—D31:F0)" on page 9-299
Device 31 Error Config Register	88h	Section 9.1.19, "D31_ERR_CFG—Device 31 Error Configuration Register (LPC I/F—D31:F0)" on page 9-300
Device 31 Error Status Register	8Ah	Section 9.1.20, "D31_ERR_STS—Device 31 Error Status Register (LPC I/F—D31:F0)" on page 9-300
PCI DMA Configuration Registers	90–91h	Section 9.1.21, "PCI_DMA_CFG—PCI DMA Configuration (LPC I/F—D31:F0)" on page 9-301
General Control	D0h–D3h	Section 9.1.22, "GEN_CNTL — General Control Register (LPC I/F — D31:F0)" on page 9-302
General Status	D4h	Section 9.1.23, "GEN_STA—General Status Register (LPC I/F—D31:F0)" on page 9-304
Backed Up Control	D5h	Section 9.1.24, "BACK_CNTL—Backed Up Control Register (LPC I/F—D31:F0)" on page 9-304
Real Time Clock Configuration	D8h	Section 9.1.25, "RTC_CONF—RTC Configuration Register (LPC I/F—D31:F0)" on page 9-305
LPC COM Port Decode Ranges	E0h	Section 9.1.26, "COM_DEC—LPC I/F Communication Port Decode Ranges (LPC I/F—D31:F0)" on page 9-305
LPC FDD & LPT Decode Ranges	E1h	Section 9.1.27, "FDD/LPT_DEC—LPC I/F FDD & LPT Decode Ranges (LPC I/F—D31:F0)" on page 9-306
LPC Sound Decode Ranges	E2h	Section 9.1.28, "SND_DEC—LPC I/F Sound Decode Ranges (LPC I/F—D31:F0)" on page 9-306
FWH Decode Enable 1 Register	E3h	Section 9.1.29, "FWH_DEC_EN1—FWH Decode Enable 1 Register (LPC I/F—D31:F0)" on page 9-307
LPC Generic Decode Range 1	E4h–E5h	Section 9.1.30, "GEN1_DEC—LPC I/F Generic Decode Range 1 Register (LPC I/F—D31:F0)" on page 9-308
LPC Enables	E6h–E7h	Section 9.1.31, "LPC_EN—LPC I/F Enables Register (LPC I/F—D31:F0)" on page 9-308
FWH Select 1 Register	E8h	Section 9.1.32, "FWH_SEL1—FWH Select 1 Register (LPC I/F—D31:F0)" on page 9-310
LPC Generic Decode Range 2	ECh–EDh	Section 9.1.33, "GEN2_DEC—LPC I/F Generic Decode Range 2 Register (LPC I/F—D31:F0)" on page 9-311

Table A-1. Intel® ICH4 PCI Configuration Registers (Sheet 5 of 10)

Register Name	Offset	Datasheet Location
FWH Select 2 Register	EE–EFh	Section 9.1.34, “FWH_SEL2—FWH Select 2 Register (LPC I/F—D31:F0)” on page 9-311
FWH Decode Enable 2 Register	F0h	Section 9.1.35, “FWH_DEC_EN2—FWH Decode Enable 2 Register (LPC I/F—D31:F0)” on page 9-312
Function Disable Register	F2h	Section 9.1.36, “FUNC_DIS—Function Disable Register (LPC I/F—D31:F0)” on page 9-313
General Power Management Configuration 1	A0h	Section 9.8.1.1, “GEN_PMCON_1—General PM Configuration 1 Register (PM—D31:F0)” on page 9-346
General Power Management Configuration 2	A2h	Section 9.8.1.2, “GEN_PMCON_2—General PM Configuration 2 Register (PM—D31:F0)” on page 9-347
General Power Management Configuration 3	A4h	Section 9.8.1.3, “GEN_PMCON_3—General PM Configuration 3 Register (PM—D31:F0)” on page 9-348
Stop Clock Delay Register	A8h	Section 9.8.1.4, “STPCLK_DEL—Stop Clock Delay Register (PM—D31:F0)” on page 9-349
GPI_ROUT	B8–BBh	Section 9.8.1.5, “GPI_ROUT—GPI Routing Control Register (PM—D31:F0)” on page 9-349
I/O Monitor Trap Forwarding Enable Register	C0h	Section 9.8.1.6, “TRP_FWD_EN—I/O Monitor Trap Forwarding Enable Register (PM—D31:F0)” on page 9-350
I/O Monitor [4:7] Trap Range Registers	C4h, C6h, C8h, CAh	Section 9.8.1.7, “MON[n]_TRP_RNG—I/O Monitor [4:7] Trap Range Register for Devices 4–7 (PM—D31:F0)” on page 9-351
I/O Monitor [4:7] Trap Mask Register	CCh	Section 9.8.1.8, “MON_TRP_MSK—I/O Monitor Trap Range Mask Register for Devices 4–7 (PM—D31:F0)” on page 9-351
IDE Controller (D31:F1)		
Vendor ID	00h–01h	Section 10.1.1, “VID—Vendor ID Register (LPC I/F—D31:F1)” on page 10-384
Device ID	02h–03h	Section 10.1.2, “DID—Device ID Register (LPC I/F—D31:F1)” on page 10-384
Command Register	04h–05h	Section 10.1.3, “CMD — Command Register (IDE—D31:F1)” on page 10-384
Device Status	06h–07h	Section 10.1.4, “STS — Device Status Register (IDE—D31:F1)” on page 10-385
Revision ID Register	08h	Section 10.1.5, “REVID—Revision ID Register (IDE—D31:F1)” on page 10-385
Programming Interface	09h	Section 10.1.6, “PI — Programming Interface Register (IDE—D31:F1)” on page 10-386
Sub Class Code	0Ah	Section 10.1.7, “SCC — Sub Class Code Register (IDE—D31:F1)” on page 10-386
Base Class Code	0Bh	Section 10.1.8, “BCC — Base Class Code Register (IDE—D31:F1)” on page 10-386
Master Latency Timer	0Dh	Section 10.1.9, “MLT — Master Latency Timer Register (IDE—D31:F1)” on page 10-387
Primary Command Block Base Address Register	10–13h	Section 10.1.10, “PCMD_BAR—Primary Command Block Base Address Register (IDE—D31:F1)” on page 10-387
Primary Control Block Base Address Register	14–17h	Section 10.1.11, “PCNL_BAR—Primary Control Block Base Address Register (IDE—D31:F1)” on page 10-387
Secondary Command Block Base Address Register	18–1Bh	Section 10.1.12, “SCMD_BAR—Secondary Command Block Base Address Register (IDE D31:F1)” on page 10-388

Table A-1. Intel® ICH4 PCI Configuration Registers (Sheet 6 of 10)

Register Name	Offset	Datasheet Location
Secondary Control Block Base Address Register	1C–1Fh	Section 10.1.13, “SCNL_BAR—Secondary Control Block Base Address Register (IDE D31:F1)” on page 10-388
Bus Master Base Address Register	20h–23h	Section 10.1.14, “BM_BASE — Bus Master Base Address Register (IDE—D31:F1)” on page 10-388
Expansion Base Address Register	24–27h	Section 10.1.15, “EXBAR — Expansion Base Address Register (IDE—D31:F1)” on page 10-389
Subsystem Vendor ID Register	2C–2Dh	Section 10.1.16, “IDE_SVID — Subsystem Vendor ID Register (IDE—D31:F1)” on page 10-389
Subsystem ID Register	2E–2Fh	Section 10.1.17, “IDE_SID — Subsystem ID Register (IDE—D31:F1)” on page 10-389
Interrupt Line Register	3Ch	Section 10.1.18, “INTR_LN—Interrupt Line Register (IDE—D31:F1)” on page 10-390
Interrupt Pin Register	3Dh	Section 10.1.19, “INTR_PN—Interrupt Pin Register (IDE—D31:F1)” on page 10-390
IDE Timing Register	40h–43h	Section 10.1.20, “IDE_TIM — IDE Timing Register (IDE—D31:F1)” on page 10-390
Slave IDE Timing	44h	Section 10.1.21, “SLV_IDETIM—Slave (Drive 1) IDE Timing Register (IDE—D31:F1)” on page 10-392
Synchronous DMA Control Register	48h	Section 10.1.22, “SDMA_CNT—Synchronous DMA Control Register (IDE—D31:F1)” on page 10-393
Synchronous DMA Timing Register	4Ah–4Bh	Section 10.1.23, “SDMA_TIM—Synchronous DMA Timing Register (IDE—D31:F1)” on page 10-394
IDE I/O Configuration Register	54–57h	Section 10.1.24, “IDE_CONFIG—IDE I/O Configuration Register (IDE—D31:F1)” on page 10-395
USB Controller (D31:F0,F1,F2)		
Vendor ID	00–01h	Section 11.1.1, “VID—Vendor Identification Register (USB—D29:F0/F1/F2)” on page 11-399
Device ID	02–03h	Section 11.1.2, “DID—Device Identification Register (USB—D29:F0/F1/F2)” on page 11-400
Command Register	04–05h	Section 11.1.3, “CMD—Command Register (USB—D29:F0/F1/F2)” on page 11-400
Device Status	06–07h	Section 11.1.4, “STA—Device Status Register (USB—D29:F0/F1/F2)” on page 11-401
Revision ID	08h	Section 11.1.5, “RID—Revision Identification Register (USB—D29:F0/F1/F2)” on page 11-401
Programming Interface	09h	Section 11.1.6, “PI—Programming Interface (USB—D29:F0/F1/F2)” on page 11-401
Sub Class Code	0Ah	Section 11.1.7, “SCC—Sub Class Code Register (USB—D29:F0/F1/F2)” on page 11-402
Base Class Code	0Bh	Section 11.1.8, “BCC—Base Class Code Register (USB—D29:F0/F1/F2)” on page 11-402
Header Type Register	0Eh	Section 11.1.9, “HTYPE—Header Type Register (USB—D29:F0/F1/F2)” on page 11-402
Base Address Register	20–23h	Section 11.1.10, “BASE—Base Address Register (USB—D29:F0/F1/F2)” on page 11-403
Subsystem Vendor ID Register	2C–2Dh	Section 11.1.11, “SVID — Subsystem Vendor ID (USB—D29:F0/F1/F2)” on page 11-403

Table A-1. Intel® ICH4 PCI Configuration Registers (Sheet 7 of 10)

Register Name	Offset	Datasheet Location
Subsystem ID Register	2E–2Fh	Section 11.1.12, “SID — Subsystem ID (USB—D29:F0/F1/F2)” on page 11-403
Interrupt Line	3Ch	Section 11.1.13, “INTR_LN—Interrupt Line Register (USB—D29:F0/F1/F2)” on page 11-404
Interrupt Pin	3Dh	Section 11.1.14, “INTR_PN—Interrupt Pin Register (USB—D29:F0/F1/F2)” on page 11-404
Serial Bus Release Number	60h	Section 11.1.15, “USB_RELNUM—USB Release Number Register (USB—D29:F0/F1/F2)” on page 11-404
USB Legacy Keyboard/Mouse Control	C0–C1h	Section 11.1.16, “USB_LEGKEY—USB Legacy Keyboard/Mouse Control Register (USB—D29:F0/F1/F2)” on page 11-405
USB Resume Enable	C4h	Section 11.1.17, “USB_RES—USB Resume Enable Register (USB—D29:F0/F1/F2)” on page 11-406
USB EHCI Controller (D29:F7)		
Command Register	04–05h	Section 12.1.3, “PCICMD—PCI Command Register (USB EHCI—D29:F7)” on page 12-419
Device Status	06–07h	Section 12.1.4, “PCISTS—PCI Device Status Register (USB EHCI—D29:F7)” on page 12-420
Revision ID	08h	Section 12.1.5, “REVID—Revision ID Register (USB EHCI—D29:F7)” on page 12-420
Programming Interface	09h	Section 12.1.6, “PI—Programming Interface Register (USB EHCI—D29:F7)” on page 12-421
Sub Class Code	0Ah	Section 12.1.7, “SCC—Sub Class Code Register (USB EHCI—D29:F7)” on page 12-421
Base Class Code	0Bh	Section 12.1.8, “BCC—Base Class Code Register (USB EHCI—D29:F7)” on page 12-421
Master Latency Timer	0Eh	Section 12.1.9, “MLT—PCI Master Latency Timer Register (USB EHCI—D29:F7)” on page 12-421
Memory Base Address Register	10–13h	Section 12.1.10, “MEM_BASE—Memory Base Address Register (USB EHCI—D29:F7)” on page 12-422
Subsystem Vendor ID	2C–2Dh	Section 12.1.11, “SVID—USB EHCI Subsystem Vendor ID Register (USB EHCI—D29:F7)” on page 12-422
Subsystem ID	2E–2Fh	Section 12.1.12, “SID—USB EHCI Subsystem ID Register (USB EHCI—D29:F7)” on page 12-422
Capabilities Pointer	34h	Section 12.1.13, “CAP_PTR—Capabilities Pointer Register (USB EHCI—D29:F7)” on page 12-423
Interrupt Line	3Ch	Section 12.1.14, “INT_LN—Interrupt Line Register (USB EHCI—D29:F7)” on page 12-423
Interrupt Pin	3Dh	Section 12.1.15, “INT_PN—Interrupt Pin Register (USB EHCI—D29:F7)” on page 12-423
Power Management Capability ID	50h	Section 12.1.16, “PWR_CAPID—PCI Power Management Capability ID Register (USB EHCI—D29:F7)” on page 12-423
Next Item Ptr	51h	Section 12.1.17, “NXT_PTR1—Next Item Pointer #1 Register (USB EHCI—D29:F7)” on page 12-424
Power Mgt Capabilities	52–53h	Section 12.1.18, “PWR_CAP—Power Management Capabilities Register (USB EHCI—D29:F7)” on page 12-424
Power Mgt Control/Status	54–55h	Section 12.1.19, “PWR_CNTL_STS—Power Management Control/Status Register (USB EHCI—D29:F7)” on page 12-425

Table A-1. Intel® ICH4 PCI Configuration Registers (Sheet 8 of 10)

Register Name	Offset	Datasheet Location
Debug Port Capability ID	58h	Section 12.1.20, "DEBUG_CAPID—Debug Port Capability ID Register (USB EHCI—D29:F7)" on page 12-425
Next Item Ptr #2	59h	Section 12.1.21, "NXT_PTR2—Next Item Pointer #2 Register (USB EHCI—D29:F7)" on page 12-426
Debug Port Base Offset	5A–5Bh	Section 12.1.22, "DEBUG_BASE—Debug Port Base Offset Register (USB EHCI—D29:F7)" on page 12-426
USB Release Number	60h	Section 12.1.23, "USB_RELNUM—USB Release Number Register (USB EHCI—D29:F7)" on page 12-426
Frame Length Adjustment	61h	Section 12.1.24, "FL_ADJ—Frame Length Adjustment Register (USB EHCI—D29:F7)" on page 12-427
Power Wake Capabilities	62–63h	Section 12.1.25, "PWAKE_CAP—Port Wake Capability Register (USB EHCI—D29:F7)" on page 12-427
USB EHCI Legacy Support Extended Capability	68–6Bh	Section 12.1.26, "LEG_EXT_CAP—USB EHCI Legacy Support Extended Capability Register (USB EHCI—D29:F7)" on page 12-428
USB EHCI Legacy Support Control/Status	6C–6Fh	Section 12.1.27, "LEG_EXT_CS—USB EHCI Legacy Support Extended Control / Status Register (USB EHCI—D29:F7)" on page 12-428
Intel Specific USB EHCI SMI	70–73h	Section 12.1.28, "SPECIAL_SMI—Intel Specific USB EHCI SMI Register (USB EHCI—D29:F7)" on page 12-430
Access Control	80h	Section 12.1.29, "ACCESS_CNTL—Access Control Register (USB EHCI—D29:F7)" on page 12-431
USB HS Reference Voltage Register	DC–DFh	Section 12.1.30, "HS_Ref_V—USB HS Reference Voltage Register (USB EHCI—D29:F7)" on page 12-431
SMBus Controller (D31:F3)		
Vendor ID	00–01h	Section 13.1.1, "VID—Vendor Identification Register (SMBUS—D31:F3)" on page 13-451
Device ID	02–03h	Section 13.1.2, "DID—Device Identification Register (SMBUS—D31:F3)" on page 13-451
Command Register	04–05h	Section 13.1.3, "CMD—Command Register (SMBUS—D31:F3)" on page 13-452
Device Status	06–07h	Section 13.1.4, "STA—Device Status Register (SMBUS—D31:F3)" on page 13-452
Revision ID Register	08h	Section 13.1.5, "REVID—Revision ID Register (SMBUS—D31:F3)" on page 13-453
Sub Class Code	0Ah	Section 13.1.6, "SCC—Sub Class Code Register (SMBUS—D31:F3)" on page 13-453
Base Class Code	0Bh	Section 13.1.7, "BCC—Base Class Code Register (SMBUS—D31:F3)" on page 13-453
SMB Base Address Register	20–23h	Section 13.1.8, "SMB_BASE—SMBUS Base Address Register (SMBUS—D31:F3)" on page 13-453
Subsystem Vendor ID Register	2C–2Dh	Section 13.1.9, "SVID — Subsystem Vendor ID (SMBUS—D31:F2/F4)" on page 13-454
Subsystem ID Register	2E–2Fh	Section 13.1.10, "SID — Subsystem ID (SMBUS—D31:F2/F4)" on page 13-454
Interrupt Line	3Ch	Section 13.1.11, "INTR_LN—Interrupt Line Register (SMBUS—D31:F3)" on page 13-454
Interrupt Pin	3Dh	Section 13.1.12, "INTR_PN—Interrupt Pin Register (SMBUS—D31:F3)" on page 13-454

Table A-1. Intel® ICH4 PCI Configuration Registers (Sheet 9 of 10)

Register Name	Offset	Datasheet Location
Host Configuration	40h	Section 13.1.13, "HOSTC—Host Configuration Register (SMBUS—D31:F3)" on page 13-455
AC '97 Audio Controller (D31:F5)		
Vendor Identification	00h–01h	Section 14.1.1, "VID—Vendor Identification Register (Audio—D31:F5)" on page 14-468
Device Identification	02h–03h	Section 14.1.2, "DID—Device Identification Register (Audio—D31:F5)" on page 14-468
PCI Command	04h–05h	Section 14.1.3, "PCICMD—PCI Command Register (Audio—D31:F5)" on page 14-469
PCI Device Status	06h–07h	Section 14.1.4, "PCISTS—PCI Device Status Register (Audio—D31:F5)" on page 14-470
Revision Identification	08h	Section 14.1.5, "RID—Revision Identification Register (Audio—D31:F5)" on page 14-471
Programming Interface	09h	Section 14.1.6, "PI—Programming Interface Register (Audio—D31:F5)" on page 14-471
Sub Class Code	0Ah	Section 14.1.7, "SCC—Sub Class Code Register (Audio—D31:F5)" on page 14-471
Base Class Code	0Bh	Section 14.1.8, "BCC—Base Class Code Register (Audio—D31:F5)" on page 14-471
Header Type	0Eh	Section 14.1.9, "HEDT—Header Type Register (Audio—D31:F5)" on page 14-472
Native Audio Mixer Base Address	10h–13h	Section 14.1.10, "NAMBAR—Native Audio Mixer Base Address Register (Audio—D31:F5)" on page 14-472
Native Audio Bus Mastering Base Address	14h–17h	Section 14.1.11, "NABMBAR—Native Audio Bus Mastering Base Address Register (Audio—D31:F5)" on page 14-473
Mixer Base Address(Mem)	18–1Bh	Section 14.1.12, "MMBAR—Mixer Base Address Register (Audio—D31:F5)" on page 14-473
Bus Master Base Address(Mem)	1C–1F	Section 14.1.13, "MBBAR—Bus Master Base Address Register (Audio—D31:F5)" on page 14-474
Subsystem Vendor ID	2Ch–2Dh	Section 14.1.14, "SVID—Subsystem Vendor ID Register (Audio—D31:F5)" on page 14-474
Subsystem ID	2Eh–2Fh	Section 14.1.15, "SID—Subsystem ID Register (Audio—D31:F5)" on page 14-475
Capabilities Pointer	34h	Section 14.1.16, "CAP_PTR—Capabilities Pointer Register (Audio—D31:F5)" on page 14-475
Interrupt Line	3Ch	Section 14.1.17, "INTR_LN—Interrupt Line Register (Audio—D31:F5)" on page 14-475
Interrupt Pin	3Dh	Section 14.1.18, "INTR_PN—Interrupt Pin Register (Audio—D31:F5)" on page 14-476
Programmable Codec ID	40h	Section 14.1.19, "PCID—Programmable Codec ID Register (Audio—D31:F5)" on page 14-476
Configuration	41h	Section 14.1.20, "CFG—Configuration Register (Audio—D31:F5)" on page 14-477
PCI Power Management ID	50–51h	Section 14.1.21, "PID—PCI Power Management Capability ID Register (Audio—D31:F5)" on page 14-477
PC -Power Management Capabilities	52–53h	Section 14.1.22, "PC—Power Management Capabilities Register (Audio—D31:F5)" on page 14-477

Table A-1. Intel® ICH4 PCI Configuration Registers (Sheet 10 of 10)

Register Name	Offset	Datasheet Location
Power Management Control and Status	54–55h	Section 14.1.23, “PCS—Power Management Control and Status Register (Audio—D31:F5)” on page 14-478
AC '97 Modem Controller (D31:F6)		
Vendor Identification	00h–01h	Section 15.1.1, “VID—Vendor Identification Register (Modem—D31:F6)” on page 15-494
Device Identification	02h–03h	Section 15.1.2, “DID—Device Identification Register (Modem—D31:F6)” on page 15-494
PCI Command	04h–05h	Section 15.1.3, “PCICMD—PCI Command Register (Modem—D31:F6)” on page 15-494
PCI Device Status	06h–07h	Section 15.1.4, “PCISTA—Device Status Register (Modem—D31:F6)” on page 15-495
Revision Identification	08h	Section 15.1.5, “RID—Revision Identification Register (Modem—D31:F6)” on page 15-495
Programming Interface	09h	Section 15.1.6, “PI—Programming Interface Register (Modem—D31:F6)” on page 15-495
Sub Class Code	0Ah	Section 15.1.7, “SCC—Sub Class Code Register (Modem—D31:F6)” on page 15-496
Base Class Code	0Bh	Section 15.1.8, “BCC—Base Class Code Register (Modem—D31:F6)” on page 15-496
Header Type	0Eh	Section 15.1.9, “HEDT—Header Type Register (Modem—D31:F6)” on page 15-496
Modem Mixer Base Address	10h–13h	Section 15.1.10, “MMBAR—Modem Mixer Base Address Register (Modem—D31:F6)” on page 15-497
Modem Base Address	14h–17h	Section 15.1.11, “MBAR—Modem Base Address Register (Modem—D31:F6)” on page 15-497
Subsystem Vendor ID	2Ch–2Dh	Section 15.1.12, “SVID—Subsystem Vendor ID (Modem—D31:F6)” on page 15-498
Subsystem ID	2Eh–2Fh	Section 15.1.13, “SID—Subsystem ID (Modem—D31:F6)” on page 15-498
Capabilities Pointer	34h	Section 15.1.14, “CAP_PTR—Capabilities Pointer (Modem—D31:F6)” on page 15-498
Interrupt Line	3C	Section 15.1.15, “INTR_LN—Interrupt Line Register (Modem—D31:F6)” on page 15-499
Interrupt Pin	3Dh	Section 15.1.16, “INT_PIN—Interrupt Pin (Modem—D31:F6)” on page 15-499
PCI Power Management ID	50–51h	Section 15.1.17, “PID—PCI Power Management Capability ID Register (Modem—D31:F6)” on page 15-499
PC - Power Management Capabilities	52–53h	Section 15.1.18, “PC—Power Management Capabilities Register (Modem—D31:F6)” on page 15-500
Power Management Control and Status	54–55h	Section 15.1.19, “PCS—Power Management Control and Status Register (Modem—D31:F6)” on page 15-500

Table A-2. Intel® ICH4 Fixed I/O Registers (Sheet 1 of 2)

Register Name	Port	Datasheet Location
DMA I/O Registers		
Channel 0 DMA Base & Current Address Register	00h	Section 9.2.1, "DMABASE_CA—DMA Base and Current Address Registers" on page 9-316
Channel 0 DMA Base & Current Count Register	01h	Section 9.2.2, "DMABASE_CC—DMA Base and Current Count Registers" on page 9-316
Channel 0 DMA Memory Low Page Register	87h	Section 9.2.3, "DMAMEM_LP—DMA Memory Low Page Registers" on page 9-317
Channel 0–3 DMA Command Register	08h	Section 9.2.4, "DMACMD—DMA Command Register" on page 9-317
Channel 0–3 DMA Status Register	08h	Section 9.2.5, "DMASTA—DMA Status Register" on page 9-318
Channel 0–3 DMA Write Single Mask Register	0Ah	Section 9.2.6, "DMA_WRSMSK—DMA Write Single Mask Register" on page 9-318
Channel 0–3 DMA Channel Mode Register	0Bh	Section 9.2.7, "DMACH_MODE—DMA Channel Mode Register" on page 9-319
Channel 0–3 DMA Clear Byte Pointer Register	0Ch	Section 9.2.8, "DMA Clear Byte Pointer Register" on page 9-319
Channel 0–3 DMA Master Clear Register	0Dh	Section 9.2.9, "DMA Master Clear Register" on page 9-320
Channel 0–3 DMA Clear Mask Register	0Eh	Section 9.2.10, "DMA_CLMSK—DMA Clear Mask Register" on page 9-320
Channel 0–3 DMA Write All Mask Register	0Fh	Section 9.2.11, "DMA_WRMSK—DMA Write All Mask Register" on page 9-320
Timer I/O Registers		
Timer Control Word Register	43h	Section 9.3.1, "TCW—Timer Control Word Register" on page 9-321
Timer Control Word Register Read Back		Section 9.3.1.1, "RDBK_CMD—Read Back Command" on page 9-322
Counter Latch Command		Section 9.3.1.2, "LTCH_CMD—Counter Latch Command" on page 9-322
Interval Timer Status Byte Format	40h	Section 9.3.2, "SBYTE_FMT—Interval Timer Status Byte Format Register" on page 9-323
Counter Access Port Register	40h	Section 9.3.3, "Counter Access Ports Register" on page 9-323
8254 Interrupt Controller		
Initialization Command Word 1 Register	20h	Section 9.4.1, "ICW1—Initialization Command Word 1 Register" on page 9-325
Initialization Command Word 2 Register	21h	Section 9.4.2, "ICW2—Initialization Command Word 2 Register" on page 9-326
Master Controller Initialization Command Word 3 Register	21h	Section 9.4.3, "ICW3—Master Controller Initialization Command Word 3 Register" on page 9-326
Slave Controller Initialization Command Word 3 Register	A1h	Section 9.4.4, "ICW3—Slave Controller Initialization Command Word 3 Register" on page 9-327
Initialization Command Word 4 Register	21h	Section 9.4.5, "ICW4—Initialization Command Word 4 Register" on page 9-327
Operational Control Word 1 Register	21h	Section 9.4.6, "OCW1—Operational Control Word 1 (Interrupt Mask) Register" on page 9-327
Operational Control Word 2 Register	20h	Section 9.4.7, "OCW2—Operational Control Word 2 Register" on page 9-328

Table A-2. Intel® ICH4 Fixed I/O Registers (Sheet 2 of 2)

Register Name	Port	Datasheet Location
Operational Control Word 3 Register	20h	Section 9.4.8, "OCW3—Operational Control Word 3 Register" on page 9-328
Master Controller Edge/Level Triggered Register	4D0h	Section 9.4.9, "ELCR1—Master Controller Edge/Level Triggered Register" on page 9-329
Slave Controller Edge/Level Triggered Register	4D1h	Section 9.4.10, "ELCR2—Slave Controller Edge/Level Triggered Register" on page 9-330
Processor Interface Registers		
NMI Status and Control Register	61h	Section 9.7.1, "NMI_SC—NMI Status and Control Register" on page 9-342
NMI Enable Register	70h	Section 9.7.2, "NMI_EN—NMI Enable (and Real Time Clock Index) Register" on page 9-343
PORT92 – Fast A20 and Init Register	92h	Section 9.7.3, "PORT92—Fast A20 and Init Register" on page 9-343
Coprocessor Error Register	F0h	Section 9.7.4, "COPROC_ERR—Coprocessor Error Register" on page 9-343
Reset Control Register	CF9h	Section 9.7.5, "RST_CNT—Reset Control Register" on page 9-344
APM I/O Decode Registers		
Advanced Power Management Control Port Register	B2h	Section 9.8.2.1, "APM_CNT—Advanced Power Management Control Port Register" on page 9-352
Advanced Power Management Status Port Register	B3h	Section 9.8.2.2, "APM_STS—Advanced Power Management Status Port Register" on page 9-352
PIO Mode Registers		
PIO Mode Command Block Offset for Secondary Drive	170h–177h	See ATA Specification for detailed register description
PIO Mode Command Block Offset for Primary Drive	1F0h–1F7h	See ATA Specification for detailed register description
PIO Mode Control Block Offset for Secondary Drive	376h	See ATA Specification for detailed register description
PIO Mode Control Block Offset for Primary Drive	3F6h	See ATA Specification for detailed register description

NOTE: When the POS_DEC_EN bit is set, additional I/O ports get positively decoded by the ICH4. Refer to through for a listing of these ranges.

Table A-3. Intel® ICH4 Variable I/O Registers (Sheet 1 of 6)

Register Name	Offset	Datasheet Location
<p>LAN Control/Status Registers (CSR) may be mapped to either I/O space or memory space. LAN CSR at CSR_IO_BASE + Offset or CSR_MEM_BASE + Offset. CSR_MEM_BASE set in Section 7.1.11, "CSR_MEM_BASE CSR — Memory-Mapped Base Address Register (LAN Controller—B1:D8:F0)" on page 7-256 CSR_IO_BASE set in Section 7.1.12, "CSR_IO_BASE — CSR I/O-Mapped Base Address Register (LAN Controller—B1:D8:F0)" on page 7-257</p>		
SCB Status Word	01h–00h	Section 7.2.1, "System Control Block Status Word Register" on page 7-262
SCB Command Word	03h–02h	Section 7.2.2, "System Control Block Command Word Register" on page 7-264
SCB General Pointer	07h–04h	Section 7.2.3, "System Control Block General Pointer Register" on page 7-266
PORT	0Bh–08h	Section 7.2.4, "PORT Register" on page 7-266
EEPROM Control Register	0Fh–0Eh	Section 7.2.5, "EEPROM Control Register" on page 7-267
MDI Control Register	13h–10h	Section 7.2.6, "Management Data Interface (MDI) Control Register" on page 7-268
Receive DMA Byte Count	17h–14h	Section 7.2.7, "Receive DMA Byte Count Register" on page 7-269
Early Receive Interrupt	18h	Section 7.2.8, "Early Receive Interrupt Register" on page 7-269
Flow Control Register	1Ah–19h	Section 7.2.9, "Flow Control Register" on page 7-270
PMDR	1Bh	Section 7.2.10, "Power Management Driver (PMDR) Register" on page 7-271
General Control	1Ch	Section 7.2.11, "General Control Register" on page 7-272
General Status	1Dh	Section 7.2.12, "General Status Register" on page 7-272
<p>Power Management I/O Registers at PMBASE+Offset PMBASE set in Section 9.1.10, "PMBASE—ACPI Base Address (LPC I/F—D31:F0)" on page 9-296</p>		
PM1 Status	00–01h	Section 9.8.3.1, "PM1_STS—Power Management 1 Status Register" on page 9-354
PM1 Enable	02–03h	Section 9.8.3.2, "PM1_EN—Power Management 1 Enable Register" on page 9-356
PM1 Control	04–07h	Section 9.8.3.3, "PM1_CNT—Power Management 1 Control Register" on page 9-357
PM1 Timer	08–0Bh	Section 9.8.3.4, "PM1_TMR—Power Management 1 Timer Register" on page 9-358
Processor Control	10h–13h	Section 9.8.3.5, "PROC_CNT—Processor Control Register" on page 9-358
Level 2 Register	14h	Section 9.8.3.6, "LV2 — Level 2 Register" on page 9-359
General Purpose Event 0 Status	28–2Bh	Section 9.8.3.7, "GPE0_STS—General Purpose Event 0 Status Register" on page 9-360
General Purpose Event 0 Enables	2C–2Fh	Section 9.8.3.8, "GPE0_EN—General Purpose Event 0 Enables Register" on page 9-362
SMI# Control and Enable	30–31h	Section 9.8.3.9, "SMI_EN—SMI Control and Enable Register" on page 9-363
SMI Status Register	34–35h	Section 9.8.3.10, "SMI_STS—SMI Status Register" on page 9-365
Alternate GPI SMI Enable	38–39h	Section 9.8.3.11, "ALT_GP_SMI_EN—Alternate GPI SMI Enable Register" on page 9-367
Alternate GPI SMI Status	3A–3Bh	Section 9.8.3.12, "ALT_GP_SMI_STS—Alternate GPI SMI Status Register" on page 9-367

Table A-3. Intel® ICH4 Variable I/O Registers (Sheet 2 of 6)

Register Name	Offset	Datasheet Location
Monitor SMI Status	40h	Section 9.8.3.13, "MON_SMI—Device Monitor SMI Status and Enable Register" on page 9-367
Device Activity Status	44h	Section 9.8.3.14, "DEVACT_STS — Device Activity Status Register" on page 9-368
Device Trap Enable	48h	Section 9.8.3.15, "DEVTRAP_EN— Device Trap Enable Register" on page 9-369
Bus Address Tracker	4Ch	Section 9.8.3.16, "BUS_ADDR_TRACK— Bus Address Tracker" on page 9-370
Bus Cycle Tracker	4Eh	Section 9.8.3.17, "BUS_CYC_TRACK— Bus Cycle Tracker" on page 9-370
TCO I/O Registers at TCOBASE + Offset TCOBASE = PMBASE + 40h PMBASE is set in Section 9.1.10, "PMBASE—ACPI Base Address (LPC I/F—D31:F0)" on page 9-296		
TCO_RLD: TCO Timer Reload and Current Value	00h	Section 9.9.1, "TCO1_RLD—TCO Timer Reload and Current Value Register" on page 9-371
TCO_TMR: TCO Timer Initial Value	01h	Section 9.9.2, "TCO1_TMR—TCO Timer Initial Value Register" on page 9-372
TCO_DAT_IN: TCO Data In	02h	Section 9.9.3, "TCO1_DAT_IN—TCO Data In Register" on page 9-372
TCO_DAT_OUT: TCO Data Out	03h	Section 9.9.4, "TCO1_DAT_OUT—TCO Data Out Register" on page 9-372
TCO1_STS: TCO Status	04h–05h	Section 9.9.5, "TCO1_STS—TCO1 Status Register" on page 9-373
TCO2_STS: TCO Status	06h–07h	Section 9.9.6, "TCO2_STS—TCO2 Status Register" on page 9-374
TCO1_CNT: TCO Control	08h–09h	Section 9.9.7, "TCO1_CNT—TCO1 Control Register" on page 9-375
TCO2_CNT: TCO Control	0Ah–0Bh	Section 9.9.8, "TCO2_CNT—TCO2 Control Register" on page 9-376
GPIO I/O Registers at GPIOBASE + Offset GPIOBASE is set in Section 9.1.14, "GPIOBASE—GPIO Base Address (LPC I/F—D31:F0)" on page 9-298		
GPIO Use Select	00–03h	Section 9.10.1, "GPIO_USE_SEL—GPIO Use Select Register" on page 9-378
GPIO Input/Output Select	04–07h	Section 9.10.2, "GP_IO_SEL—GPIO Input/Output Select Register" on page 9-379
GPIO Level for Input or Output	0C–0Fh	Section 9.10.3, "GP_LVL—GPIO Level for Input or Output Register" on page 9-379
GPIO Blink Enable	18–1Bh	Section 9.10.4, "GPO_BLINK—GPO Blink Enable Register" on page 9-380
GPIO Signal Invert	2C–2Fh	Section 9.10.5, "GPI_INV—GPIO Signal Invert Register" on page 9-381

Table A-3. Intel® ICH4 Variable I/O Registers (Sheet 3 of 6)

Register Name	Offset	Datasheet Location
BMIDE I/O Registers at BM_BASE + Offset BM_BASE is set at Section 10.1.12, “SCMD_BAR—Secondary Command Block Base Address Register (IDE D31:F1)” on page 10-388		
Command Register Primary	00h	Section 10.2.1, “BMIC[P,S]—Bus Master IDE Command Register” on page 10-397
Status Register Primary	02h	Section 10.2.2, “BMIS[P,S]—Bus Master IDE Status Register” on page 10-398
Descriptor Table Pointer Primary	04–07h	Section 10.2.3, “BMID[P,S]—Bus Master IDE Descriptor Table Pointer Register” on page 10-398
Command Register Secondary	08h	Section 10.2.1, “BMIC[P,S]—Bus Master IDE Command Register” on page 10-397
Status Register Secondary	0Ah	Section 10.2.2, “BMIS[P,S]—Bus Master IDE Status Register” on page 10-398
Descriptor Table Pointer Secondary	0C–0Fh	Section 10.2.3, “BMID[P,S]—Bus Master IDE Descriptor Table Pointer Register” on page 10-398
USB I/O Registers at Base Address + Offset USB Base Address is set at Section 11.1.10, “BASE—Base Address Register (USB—D29:F0/F1/F2)” on page 11-403		
USB Command Register	00–01h	Section 11.2.1, “USBCMD—USB Command Register” on page 11-408
USB Status Register	02–03h	Section 11.2.2, “USBSTS—USB Status Register” on page 11-411
USB Interrupt Enable	04–05h	Section 11.2.3, “USBINTR—Interrupt Enable Register” on page 11-412
USB Frame Number	06–07h	Section 11.2.4, “FRNUM—Frame Number Register” on page 11-412
USB Frame List Base Address	08–0Bh	Section 11.2.5, “FRBASEADD—Frame List Base Address” on page 11-413
USB Start of Frame Modify	0Ch	Section 11.2.6, “SOFMOD—Start of Frame Modify Register” on page 11-414
Port 0, 2, 4 Status/Control	10–11h	Section 11.2.7, “PORTSC[0,1]—Port Status and Control Register” on page 11-415
Port 1, 3, 5 Status/Control	12–13h	Section 11.2.7, “PORTSC[0,1]—Port Status and Control Register” on page 11-415
SMBus I/O Registers at SMB_BASE + Offset SMB_BASE is set at Section 13.1.8, “SMB_BASE—SMBUS Base Address Register (SMBUS—D31:F3)” on page 13-453		
Host Status	00h	Section 13.2.1, “HST_STS—Host Status Register” on page 13-456
Host Control	02h	Section 13.2.2, “HST_CNT—Host Control Register” on page 13-458
Host Command	03h	Section 13.2.3, “HST_CMD—Host Command Register” on page 13-459
Transmit Slave Address	04h	Section 13.2.4, “XMIT_SLVA—Transmit Slave Address Register” on page 13-459
Host Data 0	05h	Section 13.2.5, “HST_D0—Data 0 Register” on page 13-459
Host Data 1	06h	Section 13.2.6, “HST_D1—Data 1 Register” on page 13-460
Block Data Byte	07h	Section 13.2.7, “Host_BLOCK_DB—Host Block Data Byte Register” on page 13-460
Packet Error Check	08h	Section 13.2.8, “PEC—Packet Error Check (PEC) Register” on page 13-460
Receive Slave Address	09h	Section 13.2.9, “RCV_SLVA—Receive Slave Address Register” on page 13-461
Receive Slave Data	0Ah	Section 13.2.10, “SLV_DATA—Receive Slave Data Register” on page 13-461

Table A-3. Intel® ICH4 Variable I/O Registers (Sheet 4 of 6)

Register Name	Offset	Datasheet Location
Auxiliary Status	0Ch	Section 13.2.11, "AUX_STS—Auxiliary Status Register" on page 13-461
Auxiliary Control	0Dh	Section 13.2.12, "AUX_CTL—Auxiliary Control Register" on page 13-462
AC '97 Audio I/O Registers at NAMBAR + Offset NAMBAR is set at Section 14.1.11, "NABMBAR—Native Audio Bus Mastering Base Address Register (Audio—D31:F5)" on page 14-473		
PCM In Buffer Descriptor list Base Address Register	00h	Section 14.2.1, "x_BDBAR—Buffer Descriptor Base Address Register" on page 14-482
PCM In Current Index Value	04h	Section 14.2.2, "x_CIV—Current Index Value Register" on page 14-483
PCM In Last Valid Index	05h	Section 14.2.3, "x_LVI—Last Valid Index Register" on page 14-483
PCM In Status Register	06h	Section 14.2.4, "x_SR—Status Register" on page 14-484
PCM In Position In Current Buffer	08h	Section 14.2.5, "x_PICB—Position In Current Buffer Register" on page 14-485
PCM In Prefetched Index Value	0Ah	Section 14.2.6, "x_PIV—Prefetched Index Value Register" on page 14-485
PCM In Control Register	0Bh	Section 14.2.7, "x_CR—Control Register" on page 14-486
PCM Out Buffer Descriptor list Base Address Register	10h	Section 14.2.1, "x_BDBAR—Buffer Descriptor Base Address Register" on page 14-482
PCM Out Current Index Value	14h	Section 14.2.2, "x_CIV—Current Index Value Register" on page 14-483
PCM Out Last Valid Index	15h	Section 14.2.3, "x_LVI—Last Valid Index Register" on page 14-483
PCM Out Status Register	16h	Section 14.2.4, "x_SR—Status Register" on page 14-484
PCM Out Position In Current Buffer	18h	Section 14.2.5, "x_PICB—Position In Current Buffer Register" on page 14-485
PCM Out Prefetched Index Value	1Ah	Section 14.2.6, "x_PIV—Prefetched Index Value Register" on page 14-485
PCM Out Control Register	1Bh	Section 14.2.7, "x_CR—Control Register" on page 14-486
Mic. In Buffer Descriptor list Base Address Register	20h	Section 14.2.1, "x_BDBAR—Buffer Descriptor Base Address Register" on page 14-482
Mic. In Current Index Value	24h	Section 14.2.2, "x_CIV—Current Index Value Register" on page 14-483
Mic. In Last Valid Index	25h	Section 14.2.3, "x_LVI—Last Valid Index Register" on page 14-483
Mic. In Status Register	26h	Section 14.2.4, "x_SR—Status Register" on page 14-484
Mic In Position In Current Buffer	28h	Section 14.2.5, "x_PICB—Position In Current Buffer Register" on page 14-485
Mic. In Prefetched Index Value	2Ah	Section 14.2.6, "x_PIV—Prefetched Index Value Register" on page 14-485
Mic. In Control Register	2Bh	Section 14.2.7, "x_CR—Control Register" on page 14-486
Global Control	2Ch	Section 14.2.8, "GLOB_CNT—Global Control Register" on page 14-487
Global Status	30h	Section 14.2.9, "GLOB_STA—Global Status Register" on page 14-488
Codec Access Semaphore Register	34h	Section 14.2.10, "CAS—Codec Access Semaphore Register" on page 14-490
AC '97 Audio I/O Registers at MBBAR + Offset MBBAR is set at Section 14.1.13, "MBBAR—Bus Master Base Address Register (Audio—D31:F5)" on page 14-474		
Mic. 2 Buffer Descriptor list Base Address Register	40–43h	Section 14.2.1, "x_BDBAR—Buffer Descriptor Base Address Register" on page 14-482
Mic. 2 Current Index Value	44h	Section 14.2.2, "x_CIV—Current Index Value Register" on page 14-483

Table A-3. Intel® ICH4 Variable I/O Registers (Sheet 5 of 6)

Register Name	Offset	Datasheet Location
Mic. 2 Last Valid Index	45h	Section 14.2.3, "x_LVI—Last Valid Index Register" on page 14-483
Mic. 2 Status Register	46–47h	Section 14.2.4, "x_SR—Status Register" on page 14-484
Mic 2 Position In Current Buffer	48–49h	Section 14.2.5, "x_PICB—Position In Current Buffer Register" on page 14-485
Mic. 2 Prefetched Index Value	4Ah	Section 14.2.6, "x_PIV—Prefetched Index Value Register" on page 14-485
Mic. 2 Control Register	4Bh	Section 14.2.7, "x_CR—Control Register" on page 14-486
PCM In 2 Buffer Descriptor list Base Address Register	50–53h	Section 14.2.1, "x_BDBAR—Buffer Descriptor Base Address Register" on page 14-482
PCM In 2 Current Index Value	54h	Section 14.2.2, "x_CIV—Current Index Value Register" on page 14-483
PCM In 2 Last Valid Index	55h	Section 14.2.3, "x_LVI—Last Valid Index Register" on page 14-483
PCM In 2 Status Register	56–57h	Section 14.2.4, "x_SR—Status Register" on page 14-484
PCM In 2 Position In Current Buffer	58–59h	Section 14.2.5, "x_PICB—Position In Current Buffer Register" on page 14-485
PCM In 2 Prefetched Index Value	5Ah	Section 14.2.6, "x_PIV—Prefetched Index Value Register" on page 14-485
PCM In 2 Control Register	5Bh	Section 14.2.7, "x_CR—Control Register" on page 14-486
S/PDIF Buffer Descriptor list Base Address Register	60–63	Section 14.2.1, "x_BDBAR—Buffer Descriptor Base Address Register" on page 14-482
S/PDIF Current Index Value	64h	Section 14.2.2, "x_CIV—Current Index Value Register" on page 14-483
S/PDIF Last Valid Index	65h	Section 14.2.3, "x_LVI—Last Valid Index Register" on page 14-483
S/PDIF Status Register	66–67h	Section 14.2.4, "x_SR—Status Register" on page 14-484
S/PDIF Position In Current Buffer	68–69h	Section 14.2.5, "x_PICB—Position In Current Buffer Register" on page 14-485
S/PDIF Prefetched Index Value	6Ah	Section 14.2.6, "x_PIV—Prefetched Index Value Register" on page 14-485
S/PDIF Control Register	6Bh	Section 14.2.7, "x_CR—Control Register" on page 14-486
SDATA_IN Map Register	80	Section 14.2.11, "SDM—SDATA_IN Map Register" on page 14-491
AC '97 Modem I/O Registers at MBAR + Offset MBAR is set in Section 15.1.11, "MBAR—Modem Base Address Register (Modem—D31:F6)" on page 15-497		
Modem In Buffer Descriptor List Base Address Register	00h	Section 15.2.1, "x_BDBAR—Buffer Descriptor List Base Address Register" on page 15-503
Modem In Current Index Value Register	04h	Section 15.2.2, "x_CIV—Current Index Value Register" on page 15-503
Modem In Last Valid Index Register	05h	Section 15.2.3, "x_LVI—Last Valid Index Register" on page 15-503
Modem In Status Register	06h	Section 15.2.4, "x_SR—Status Register" on page 15-504
Modem In Position In Current Buffer Register	08h	Section 15.2.5, "x_PICB—Position in Current Buffer Register" on page 15-505
Modem In Prefetch Index Value Register	0Ah	Section 15.2.6, "x_PIV—Prefetch Index Value Register" on page 15-505
Modem In Control Register	0Bh	Section 15.2.7, "x_CR—Control Register" on page 15-506
Modem Out Buffer Descriptor List Base Address Register	10h	Section 15.2.1, "x_BDBAR—Buffer Descriptor List Base Address Register" on page 15-503
Modem Out Current Index Value Register	14h	Section 15.2.2, "x_CIV—Current Index Value Register" on page 15-503

Table A-3. Intel® ICH4 Variable I/O Registers (Sheet 6 of 6)

Register Name	Offset	Datasheet Location
Modem Out Last Valid Register	15h	Section 15.2.3, “x_LVI—Last Valid Index Register” on page 15-503
Modem Out Status Register	16h	Section 15.2.4, “x_SR—Status Register” on page 15-504
Modem In Position In Current Buffer Register	18h	Section 15.2.5, “x_PICB—Position in Current Buffer Register” on page 15-505
Modem Out Prefetched Index Register	1Ah	Section 15.2.6, “x_PIV—Prefetch Index Value Register” on page 15-505
Modem Out Control Register	1Bh	Section 15.2.7, “x_CR—Control Register” on page 15-506
Global Control	3Ch	Section 15.2.8, “GLOB_CNT—Global Control Register” on page 15-507
Global Status	40h	Section 15.2.9, “GLOB_STA—Global Status Register” on page 15-508
Codec Access Semaphore Register	44h	Section 15.2.10, “CAS—Codec Access Semaphore Register” on page 15-510

Numerics

64_EN 346
 64-bit Addressing Capability 434
 66 MHz Capable 254, 278, 282, 385, 401, 420,
 452, 470, 495

A

A20Gate Pass-Through Enable 406
 AC 507
 AC '97 Cold Reset# 488, 507
 AC_SDIN0 Codec Ready 490, 509
 AC_SDIN0 Resume Interrupt 489, 509
 AC_SDIN0 Resume Interrupt Enable 487, 507
 AC_SDIN1 Codec Ready 489, 509
 AC_SDIN1 Resume Interrupt 489, 509
 AC_SDIN1 Resume Interrupt Enable 487, 507
 AC_SDIN2 Codec Ready 488, 508
 AC_SDIN2 Interrupt Enable 487, 507
 AC_SDIN2 Resume Interrupt 488, 508
 AC '97 Warm Reset 488, 507
 AC97_EN 362
 AC97_STS 361
 ACLINK Shut Off 487, 507
 AD3 489, 508
 ADDRESS 459
 Address Increment/Decrement Select 319
 Address of Descriptor Table 398
 ADLIB_ACT_STS 368
 ADLIB_LPC_EN 309
 ADLIB_TRP_EN 369
 AFTERG3_EN 348
 Alarm Flag 341
 Alarm Interrupt Enable 340
 Alternate A20 Gate 343
 Alternate Access Mode Enable 303
 Alternate GPI SMI Enable 367
 Alternate GPI SMI Status 367
 APIC Data 332
 APIC Enable 303
 APIC ID 333
 APIC Index 332
 APM_STS 366
 APMC_EN 364
 Asynchronous Schedule Enable 436
 Asynchronous Schedule Park Capability 434
 Asynchronous Schedule Status 438

AUDIO_ACT_STS 368
 AUDIO_TRP_EN 369
 Autoinitialize Enable 319
 Automatic End of Interrupt 327
 Automatically Append CRC 462
 Auxiliary Current 260, 424, 477

B

BAR Number 426
 Base Address 256, 257, 387, 388, 403, 413,
 453, 472, 473, 474, 497
 Base and Current Address 316
 Base and Current Count 316
 Base Class Code 255, 386, 402, 453, 471, 496
 Binary/BCD Countdown Select 321
 BIOS_EN 364
 BIOS_STS 366
 BIOSWR_STS 373
 Bit 1 of slot 12 489, 509
 Bit 2 of slot 12 489, 509
 Bit 3 of slot 12 489, 509
 Bit Clock Stopped 488, 508
 Block Data 460
 BOOT_STS 374
 Buffer Completion Interrupt Status 484, 504
 Buffer Descriptor Base Address 482
 Buffer Descriptor List Base Address 503
 Buffered Mode 327
 Bus Master Enable 253, 384, 400, 419, 452,
 469, 494
 Bus Master IDE Active 398
 BUS_ERR 457
 Byte Done Status 456

C

Cache Line Size 255
 Capabilities 475
 Capabilities List 254, 420, 470, 495
 Capabilities Pointer 258, 423, 475, 498
 Capability ID 259, 428, 477
 Cascaded Interrupt Controller IRQ Connection
 326
 Channel 1 Select 301
 Channel 2 Select 301
 Channel 3 Select 301
 Channel 5 Select 301
 Channel 6 Select 301

- Channel 7 Select 301
- Channel Mask Bits 320
- Channel Mask Select 318
- Channel Request Status 318
- Channel Terminal Count Status 318
- Clear Byte Pointer 319
- Clear Mask Register 320
- CNA Mask 264
- CNF1_LPC_EN 308
- CNF2_LPC_EN 308
- Codec Access Semaphore 490, 510
- COMA Decode Range 305
- COMA_LPC_EN 309
- COMB Decode Range 305
- COMB_LPC_EN 309
- Command Unit (CU) Executed 262
- Command Unit Command 265
- Command Unit Status 263
- Configure Flag 408
- Connect Status Change 416, 446
- COPROC_ERR 343
- Coprocessor Error Enable 302
- Count Register Status 323
- Countdown Type Status 323
- Counter 0 Select 322
- Counter 1 Select 322
- Counter 2 Select 322
- Counter Latch Command 322
- Counter Mode Selection 321
- Counter OUT Pin State 323
- Counter Port 323
- Counter Select 321
- Counter Selection 322
- CPU BIST Enable 304
- CPU Break Event Indication Enable 302
- CPU Frequency Strap 304
- CPU PLL Lock Time 347
- CPU Power Failure 347
- CPU SLP# Enable 346
- CPU Thermal Trip Status 347
- CRC Error 461
- CU Not Active 262
- Current Connect Status 416, 446
- Current Equals Last Valid 484, 504
- Current Index Value 483, 503
- CX Mask 264

- D**
- D1 Support 260, 424
- D2 Support 260, 424
- D29_F0_Disable 313
- D29_F1_Disable 313
- D29_F2_Disable 313
- D29_F7_Disable 313
- D31_F1_Disable 314
- D31_F3_Disable 314
- D31_F5_Disable 313
- D31_F6_Disable 313
- Data 268
- Data Message Byte 0 461
- Data Message Byte 1 461
- Data Mode 340
- Data Parity Error Detected 254, 385, 401, 452, 470, 495
- Data Scale 260, 425
- Data Select 260, 425
- DATA_BUFFER 449
- DATA_HIGH_BYTE 465
- DATA_LEN_CNT 448
- DATA_LOW_BYTE 465
- DATA0/COUNT 459
- DATA1 460
- Date Alarm 341
- Daylight Savings Enable 340
- Debug Port Number 433
- Debug Port Offset 426
- Deep Power-Down on Link Down Enable 272
- Delayed Transaction Enable 303
- Delivery Mode 336
- Delivery Status 336
- Delivery Type 334
- Destination 335
- Destination Mode 336
- Detected Parity Error 254, 385, 420, 452, 470, 495
- DEV_ERR 457
- DEV_TRAP_EN 367
- DEV_TRAP_STS 367
- Device Connects 203
- Device Identification Value 252, 276, 384, 400, 418, 451, 468, 494
- Device Monitor Status 366
- Device Specific Initialization 260, 477
- DEVICE_ADDRESS 464
- DEVSEL# Timing Status 254, 385, 401, 420, 452, 470, 495
- Diagnose Result 267
- Division Chain Select 339
- DMA Channel Group Enable 317
- DMA Channel Select 318, 319
- DMA Collection Buffer Enable 303
- DMA Controller Halted 484, 504
- DMA Group Arbitration Priority 317

- DMA Low Page 317
- DMA Transfer Mode 319
- DMA Transfer Type 319
- DONE_STS 448
- Drive 0 DMA Capable 398
- Drive 0 DMA Timing Enable 391
- Drive 0 Fast Timing Bank 391
- Drive 0 IORDY Sample Point Enable 391
- Drive 0 Prefetch/Posting Enable 391
- Drive 1 DMA Capable 398
- Drive 1 DMA Timing Enable 391
- Drive 1 Fast Timing Bank 391
- Drive 1 IORDY Sample Point Enable 391
- Drive 1 Prefetch/Posting Enable 391
- Drive 1 Timing Register Enable 390
- DSI 424
- Duplex Mode 272
- Dynamic Data 260
- E**
- Early Receive 263
- Early Receive Count 269
- Edge/Level Bank Select 325
- EEPROM Chip Select 267
- EEPROM Serial Clock 267
- EEPROM Serial Data In 267
- EEPROM Serial Data Out 267
- EHC Initialization 195
- EHC Resets 196
- EHCI Extended Capabilities Pointer 434
- Enable 32-byte Buffer 462
- Enable Special Mask Mode 328
- ENABLED_CNT 448
- End of SMI 364
- Enter Global Suspend Mode 408
- ER Mask 264
- Error 398
- ERROR_GOOD#_STS 448
- EXCEPTION_STS 448
- Extended Destination ID 335
- F**
- FAILED 457
- Fast Back to Back Capable 254, 278, 282, 385, 401, 420, 452, 470, 495
- Fast Back to Back Enable 253, 277, 384, 400, 419, 452, 469, 494
- Fast Primary Drive 0 Base Clock 395
- Fast Primary Drive 1 Base Clock 395
- Fast Secondary Drive 0 Base Clock 395
- Fast Secondary Drive 1 Base Clock 395
- FC Full 270
- FC Paused 270
- FC Paused Low 270
- FCP Mask 264
- FDD Decode Range 306
- FDD_LPC_EN 309
- FIFO Error 484, 504
- FIFO Error Interrupt Enable 486, 506
- Flow Control Pause 263
- Flow Control Threshold 270
- Force Global Resume 408
- Force Port Resume 446
- Force Thermal Throttling 358
- FR Mask 264
- Frame Length Timing Value 427
- Frame List Current Index/Frame Number 412, 441
- Frame List Rollover 439
- Frame List Rollover Enable 440
- Frame List Size 436
- Frame Received 262
- Full Reset 344
- FWH_C0_EN 307, 312
- FWH_C0_IDSEL 310
- FWH_C8_EN 307, 312
- FWH_C8_IDSEL 310
- FWH_D0_EN 307, 312
- FWH_D0_IDSEL 310
- FWH_D8_EN 307, 312
- FWH_D8_IDSEL 310, 311
- FWH_E0_EN 307
- FWH_E0_IDSEL 310, 311
- FWH_E8_EN 307
- FWH_E8_IDSEL 310, 311
- FWH_F0_EN 307
- FWH_F0_IDSEL 310, 311
- FWH_F8_EN 307
- FWH_F8_IDSEL 310
- G**
- GAMEH_LPC_EN 308
- GAMEL_LPC_EN 308
- GBL_SMI_EN 364
- General Self-Test Result 267
- Generic Decode Range 1 Enable 308
- Generic I/O Decode Range 1 Base Address 308
- Generic I/O Decode Range 2 Base Address 311
- Generic I/O Decode Range 2 Enable 311
- Global Enable 356
- Global Release 357
- Global Reset 409
- Global Status 355
- GO_CNT 448

- GP_BLINK(n) 380
- GP_INV(n) 381
- GP_IO_SEL2 382
- GP_LVL(n) 379
- GP_LVL2 382
- GPE0_STS 366
- GPI Interrupt Enable 488, 507
- GPI Status Change Interrupt 490, 509
- GPIO Route 349
- GPI1 Route 349
- GPI15 Route 349
- GPI2 Route 349
- GPIIn_EN 362
- GPIIn_STS 360
- GPIO_SEL 379
- GPIO_USE_SEL 378
- GPIO_USE_SEL2 381
- GPIO11_ALERT_DISABLE 376

- H**
- HC BIOS Owned Semaphore 428
- HC OS Owned Semaphore 428
- HCHalted 411, 438
- Header Type 256, 402, 472, 496
- Host Controller Process Error 411
- Host Controller Reset 409, 437
- Host System Error 411, 438
- Host System Error Enable. 440
- HOST_BUSY 457
- HOST_NOTIFY_INTREN 464
- HOST_NOTIFY_STS 463
- HOST_NOTIFY_WKEN 464
- Hour Format 340
- HUBNMI_STS 373
- HUBSCI_STS 373
- HUBSERR_STS 373
- HUBSMI_STS 373

- I**
- I/O (x) Extension Enable 303
- I/O APIC Identification 334
- I/O Space Enable 253, 385, 400, 419, 452, 469, 477, 494
- I/O Space Indicator 257, 453
- I2C 218, 219
- I2C_EN 455
- ICW/OCW Select 325
- ICW4 Write Required 325
- IDE Decode Enable 390
- IDEP0_ACT_STS 369
- IDEP0_TRP_EN 370
- IDEP1_ACT_STS 369
- IDEP1_TRP_EN 370
- IDES0_ACT_STS 369
- IDES0_TRP_EN 370
- IDES1_ACT_STS 368
- IDES1_TRP_EN 369
- IN_USE_CNT 448
- INIT_NOW 343
- INTEL_USB2_EN 363
- INTEL_USB2_STS 365
- Interesting Packet 271
- Interrupt 398
- Interrupt Enable 268
- Interrupt Input Pin Polarity 335
- Interrupt Level Select 328
- Interrupt Line 258, 390, 404, 423, 454, 475, 499
- Interrupt Mask 264
- Interrupt on Async Advance 438
- Interrupt on Async Advance Doorbell 436
- Interrupt on Async Advance Enable 440
- Interrupt On Complete (IOC) Enable 412
- Interrupt On Completion Enable 486, 506
- Interrupt Pin 258, 390, 404, 423, 454, 476, 499
- Interrupt Request Flag 341
- Interrupt Request Level 326
- Interrupt Request Mask 327
- Interrupt Routing Enable 299
- Interrupt Threshold Control 436
- Interrupt Vector Base Address 326
- INTR 457
- INTRD_SEL 376
- INTREN 459
- Intruder Detect 374
- INUSE_STS 457
- IOCHK# NMI Enable 342
- IOCHK# NMI Source Status 342
- IORDY Sample Point 390
- IRQ Number 332
- IRQ Routing 299
- IRQ1_CAUSE 377
- IRQ10 ECL 330
- IRQ11 ECL 330
- IRQ12 ECL 330
- IRQ12_CAUSE 377
- IRQ14 ECL 330
- IRQ15 ECL 330
- IRQ3 ECL 329
- IRQ4 ECL 329
- IRQ5 ECL 329
- IRQ6 ECL 329
- IRQ7 ECL 329
- IRQ9 ECL 330

Isochronous Scheduling Threshold 434

K

KBC_ACT_STS 368
 KBC_LPC_EN 308
 KBC_TRP_EN 369
 Keyboard IRQ1 Latch Enable 302
 KILL 459

L

LAN Connect Address 268
 LAN Connect Register Address 268
 LAN Connect Software Reset 272
 Last Codec Read Data Input 491
 Last Valid Buffer Completion Interrupt 484, 504
 Last Valid Buffer Interrupt Enable 486, 506
 Last Valid Index 483, 503
 Latch Count of Selected Counters 322
 Latch Status of Selected Counters 322
 LEG_ACT_STS 368
 LEG_IO_TRP_EN 369
 LEGACY_USB_EN 364
 LEGACY_USB_STS 366
 LEGACY_USB2_EN 363
 LEGACY_USB2_STS 365
 Light Host Controller Reset 436
 Line Status 416, 445
 Link Pointer Low 443
 Link Status Change Indication 271
 Link Status Indication 272
 LINK_ID_STS 448
 Loop Back Test Mode 408
 Low Speed Device Attached 415
 Lower 128-byte Lock 305
 LPC Bridge Disable 313
 LPT Decode Range 306
 LPT_LPC_EN 309

M

Magic Packet 271
 Management Data Interrupt 263
 Mask 335
 Master Abort Status 254, 470, 495
 Master Clear 320
 Master Data Parity Error Detected 420
 Master Latency Timer Count 256, 387
 Master/Slave in Buffered Mode 327
 Max Packet 408
 Maximum Latency 259
 Maximum Redirection Entries 334
 MC_LPC_EN 308
 MD3 489, 508

Memory Space Enable 253, 384, 400, 419, 452, 469, 494
 Memory Space Indicator 256
 Memory Write and Invalidate Enable 253, 277, 469, 494
 Mic In Interrupt 490, 509
 Microcontroller SMI Enable 363
 Microcontroller SMI# Status 366
 Microphone 2 In Interrupt 489, 508
 Microprocessor Mode 327
 MIDI Decode Range 306
 MIDI_ACT_STS 368
 MIDI_LPC_EN 309
 MIDI_TRP_EN 369
 Minimum Grant 258
 Mode Selection Status 323
 Modem In Interrupt 490, 509
 Modem Out Interrupt 490, 509
 MON_TRAP_BASE 351
 MON4_FWD_EN 350
 MON4_MASK 351
 MON5_FWD_EN 350
 MON5_MASK 351
 MON6_FWD_EN 350
 MON6_MASK 351
 MON7_FWD_EN 350
 MON7_MASK 351
 Mouse IRQ12 Latch Enable 302
 MSS Decode Range 306
 MSS_LPC_EN 309
 Multichannel Capabilities 489, 508
 Multi-Function Bit 402
 Multi-Function Device 256

N

N_PORTS 433
 NEWCENTURY_STS 373
 Next Capability 477
 Next EHCI Capability Pointer 428
 Next Item Pointer 259
 Next Item Pointer #1 Value 424
 NMI Enable 343
 NMI_NOW 375
 NMI2SMI_EN 374, 375
 NO_REBOOT 304
 Number of Companion Controllers 433
 Number of Ports per Companion Controller 433

O

OCW2 Select 328
 OCW3 Select 329
 Opcode 268

- Over-current Active 415, 446
- Over-current Change 446
- Over-current Indicator 415
- OWNER_CNT 447
- P**
- Parity Error Response 253, 384, 400, 419, 452, 469, 494
- Pass Through State 406
- PCI Interrupt Enable 405
- PCI SERR# Enable 342
- PCM 4/6 Enable 487
- PCM In 1, Microphone In 1 Data In Line 491
- PCM In 2 Interrupt 489, 508
- PCM In 2, Microphone In 2 Data In Line 491
- PCM In Interrupt 490, 509
- PCM Out Interrupt 490, 509
- PCM Out Mode 487
- PEC_DATA 460
- PEC_EN 458
- Periodic Interrupt Enable 340
- Periodic Interrupt Flag 341
- Periodic List Execution 197
- Periodic Schedule Enable 436
- Periodic Schedule Status 438
- Periodic SMI# Rate Select 346
- PERIODIC_EN 363
- PERIODIC_STS 365
- PIRQAE_ACT_STS 368
- PIRQBF_ACT_STS 368
- PIRQCG_ACT_STS 368
- PIRQDH_ACT_STS 368
- PM1_STS_REG 366
- PME Clock 260, 424, 477
- PME Enable 260, 425, 478, 500
- PME Status 260, 271, 425, 478, 500
- PME Support 260, 424, 477
- PME_BO_EN 362
- PME_BO_STS 360
- PME_EN 362
- PME_STS 360
- Pointer Field 266
- Poll Mode Command 329
- POP_MODE_CAP 386
- POP_MODE_SEL 386
- Port Change Detect 439
- Port Change Interrupt Enable 440
- Port Enable/Disable Change 416, 446
- Port Enabled/Disabled 416, 446
- PORT Function Selection 266
- Port Owner 445
- Port Power 445
- Port Reset 415, 445
- Port Test Control 444
- Port Wake Implemented 427
- Port Wake Up Capability Mask 427
- PORT0EN 406
- PORT1EN 406
- Port-Routing Logic 202
- Position In Current Buffer 485, 505
- Positive Decode Enable 303
- Postable Memory Write Enable 384, 400, 419, 452
- Power Button Enable 356
- Power Button Override Status 354
- Power Button Status 355
- Power Failure 348
- Power Management Capability ID 423
- Power Sequencing 537
- Power State 261, 425, 478, 500
- Prefetchable 256, 422
- Prefetched Index Value 485, 505
- PRIM_SIG_MODE 395
- Primary Drive 0 Base Clock 396
- Primary Drive 0 Cycle Time 394
- Primary Drive 0 Synchronous DMA Mode Enable 393
- Primary Drive 1 Base Clock 396
- Primary Drive 1 Cycle Time 394
- Primary Drive 1 IORDY Sample Point 392
- Primary Drive 1 Recovery Time 392
- Primary Drive 1 Synchronous DMA Mode Enable 393
- Primary Master Channel Cable Reporting 396
- Primary Slave Channel Cable Reporting 396
- Programmable Frame List Flag 434
- Programming Interface 401, 471, 495
- PRQ 334
- PWRBTN_LVL 346
- PWROK Failure 347
- R**
- Rate Select 339
- Read / Write Control 397
- Read Back Command 322
- Read Completion Status 489, 509
- Read Policies for Periodic DMA 197
- Read/Write Select 321
- Read/Write Selection Status 323
- Ready 268
- Real Time Clock Index Address 343
- Receive DMA Byte Count 269
- Receive Not Ready 263
- Receive Unit Command 265

- Receive Unit Status 263
- Received 420
- Received Master Abort 385, 401, 420, 452
- Received Target Abort 254, 420, 452
- RECEIVED_PID_STS 449
- Reclamation 438
- Recovery Time 391
- Redirection Entry Clear 333
- Refresh Cycle Toggle 342
- Register Read Command 329
- Register Result 267
- Remote IRR 335
- Reset CPU 344
- Reset Registers 486, 506
- Resource Type Indicator 387, 388, 403, 422, 472, 473, 474, 497
- Resume Detect 411, 416
- Resume Interrupt Enable 412
- Revision Identification Value 255, 385, 401, 453, 471, 495
- RI_EN 362
- RI_STS 360
- RNR Mask 264
- ROM Content Result 267
- Rotate and EOI Codes 328
- RTC Event Enable 356
- RTC Power Status 348
- RTC Status 354
- Run/Pause Bus Master 486, 506
- Run/Stop 409, 437
- RW 459

- S**
- S/PDIF Interrupt 488, 508
- S/PDIF Slot Map 487
- SAFE_MODE 304
- Sample Capabilities 489, 508
- SB16 Decode Range 306
- SB16_LPC_EN 309
- SCB General Pointer 266
- SCI Enable 357
- SEC_SIG_MODE 395
- SECOND_TO_STS 374
- Secondary Codec ID 476
- Secondary Drive 0 Base Clock 396
- Secondary Drive 0 Cycle Time 394
- Secondary Drive 0 Synchronous DMA Mode Enable 393
- Secondary Drive 1 Base Clock 396
- Secondary Drive 1 Cycle Time 394
- Secondary Drive 1 IORDY Sample Point 392
- Secondary Drive 1 Recovery Time 392
- Secondary Drive 1 Synchronous DMA Mode Enable 393
- Secondary Master Channel Cable Reporting 395
- Secondary Slave Channel Cable Reporting 395
- SEND_PID_CNT 449
- SENDNOW 375
- SERIRQ_SMI_STS 365
- SERR# Enable 253, 384, 400, 419, 452, 469, 494
- SERR# NMI Source Status 342
- Short Packet Interrupt Enable 412
- Signaled System Error 254, 385, 420, 452, 470, 495
- Signaled Target Abort 254, 385, 401, 420, 452, 470, 495
- Single or Cascade 325
- Slave Identification Code 327
- SLAVE_ADDR 461
- Sleep Enable 357
- Sleep Type 357
- SLP_SMI_EN 364
- SLP_SMI_STS 366
- SMB_CMD 458
- SMB_FOR_BIOS 314
- SMB_SMI_EN 455
- SMBALERT_DIS 464
- SMBALERT_STS 457
- SMBCLK_CTL 463
- SMBCLK_CUR_STS 463
- SMBDATA_CUR_STS 463
- SMBus Host Enable 455
- SMBus SMI Status 365
- SMBus Wake Status 361
- SMI at End of Pass-through Enable 406
- SMI Caused by End of Pass-through 405
- SMI Caused by Port 60 Read 405
- SMI Caused by Port 60 Write 405
- SMI Caused by Port 64 Read 405
- SMI Caused by Port 64 Write 405
- SMI Caused by USB Interrupt 405
- SMI on Async 430
- SMI on Async Advance 428
- SMI on Async Advance Enable 429
- SMI on Async Enable 430
- SMI on BAR 428
- SMI on BAR Enable 429
- SMI on CF 430
- SMI on CF Enable 431
- SMI on Frame List Rollover 429
- SMI on Frame List Rollover Enable 429
- SMI on HCHalted 430

- SMI on HCHalted Enable 431
 - SMI on HCRReset 430
 - SMI on HCRReset Enable 431
 - SMI on Host System Error 428
 - SMI on Host System Error Enable 429
 - SMI on OS Ownership Change 428
 - SMI on OS Ownership Enable 429
 - SMI on PCI Command 428
 - SMI on PCI Command Enable 429
 - SMI on Periodic 430
 - SMI on Periodic Enable 431
 - SMI on PMCSR 430
 - SMI on PMSR Enable 430
 - SMI on Port 60 Reads Enable 406
 - SMI on Port 60 Writes Enable 406
 - SMI on Port 64 Reads Enable 406
 - SMI on Port 64 Writes Enable 406
 - SMI on Port Change Detect 429
 - SMI on Port Change Enable 429
 - SMI on PortOwner 430
 - SMI on PortOwner Enable 430
 - SMI on USB Complete 429
 - SMI on USB Complete Enable 429
 - SMI on USB Error 429
 - SMI on USB Error Enable 429
 - SMI on USB IRQ Enable 406
 - SMI_LOCK 346
 - SMLink Slave SMI Status 374
 - SMLINK_CLK_CTL 462
 - SMLINK0_CUR_STS 462
 - SMLINK1_CUR_STS 462
 - SOF Timing Value 414
 - Software Debug 408
 - Software Generated Interrupt 264
 - Software Interrupt 263
 - Software SMI# Timer Enable 364
 - SOP_MODE_CAP 386
 - SOP_MODE_SEL 386
 - Speaker Data Enable 342
 - Special Cycle Enable 253, 277, 384, 400, 419, 452, 469, 494
 - Special Fully Nested Mode 327
 - Special Mask Mode 328
 - Speed 272
 - Square Wave Enable 340
 - START 458
 - Start/Stop Bus Master 397
 - Steer Enable 491
 - STPCLK_DE 349
 - Sub Class Code 255, 386, 402, 453, 471, 496
 - Subsystem ID 257, 389, 403, 454, 475, 498
 - Subsystem Vendor ID 257, 389, 403, 454, 474, 498
 - Suspend 415, 445
 - SW_TCO_SMI 374
 - SWSMI_RATE_SEL 348
 - SWSMI_TMR_STS 366
 - System Reset 344
 - System Reset Status 347
- T**
- TCO Timer Halt 375
 - TCO_EN 363
 - TCO_INT_STS 374
 - TCO_MESSAGE 376
 - TCO_STS 365
 - TCOSCI_EN 362
 - TCOSCI_STS 361
 - Tertiary Codec ID 476
 - Thermal Interrupt Override Status 361
 - Thermal Interrupt Status 361
 - THRM#_POL 363
 - THRM_DTY 359
 - THRM_EN 363
 - Throttle Status 358
 - THT_EN 359
 - THTL_DTY 359
 - TIMEOUT 374
 - Timeout/CRC Interrupt Enable 412
 - Timer Counter 2 Enable 342
 - Timer Counter 2 OUT Status 342
 - Timer Overflow Interrupt Enable 356
 - Timer Overflow Status 355
 - Timer Value 358
 - TOKEN_PID_CNT 449
 - Top-Block Swap Mode 304
 - Trigger Mode 335
 - Type 256, 422, 473, 474
- U**
- UHCI v/s EHCI 195
 - Update Cycle Inhibit 340
 - Update In Progress 339
 - Update-ended Flag 341
 - Update-Ended Interrupt Enable 340
 - Upper 128-byte Enable 305
 - Upper 128-byte Lock 305
 - USB Error Interrupt 411, 439
 - USB Error Interrupt Enable 440
 - USB HS Ref Voltage 431
 - USB Interrupt 411, 439
 - USB Interrupt Enable 440
 - USB Release Number 404, 426

USB_ADDRESS_CNF 450
USB_ENDPOINT_CNF 450
USB1_EN 363
USB1_STS 361
USB2_EN 362
USB2_STS 361
USB3_EN 362
USB3_STS 360
User Definable Features 254, 278, 282, 385,
401, 420, 452, 470, 495

V
Valid RAM and Time Bit 341
Vector 336
Vendor Identification Value 252, 276, 384, 399,
418, 451, 468, 494
Version 260, 334, 424, 477

VGA Palette Snoop 253, 277, 384, 400, 419,
452, 469, 494

W
Wait Cycle Control 253, 277, 384, 400, 419,
452, 469, 494
Wake Status 354
Watchdog Status 377
WR_PingPong_EN 395
Write Policies for Periodic DMA 198
WRITE_READ#_CNT 448
WRT_RDONLY 431

X
Xoff 270
Xon 270