

STE400P - 10/100 FAST ETHERNET 4 PORT TRANSCEIVER

1.0 GENERAL DESCRIPTION

The STE400P, also referred to as STEPHY4, is a high performance, four port, Fast Ethernet physical layer interface for 10BASE-T and 100BASE-TX applications. It was designed with advanced CMOS technology to provide a Media Independent Interface (MII) for easy attachment to 10/100 Media Access Controllers (MAC) and a physical media interface for 100BASE-TX and 10BASE-T. The twisted pair interface directly drives a 10/100 twisted pair connection. STE400P is an excellent device perfectly suited for hub, switch, router and other embedded Ethernet applications.

The system diagram is as shown below:

Figure 1. System Diagram of the STE400P Application

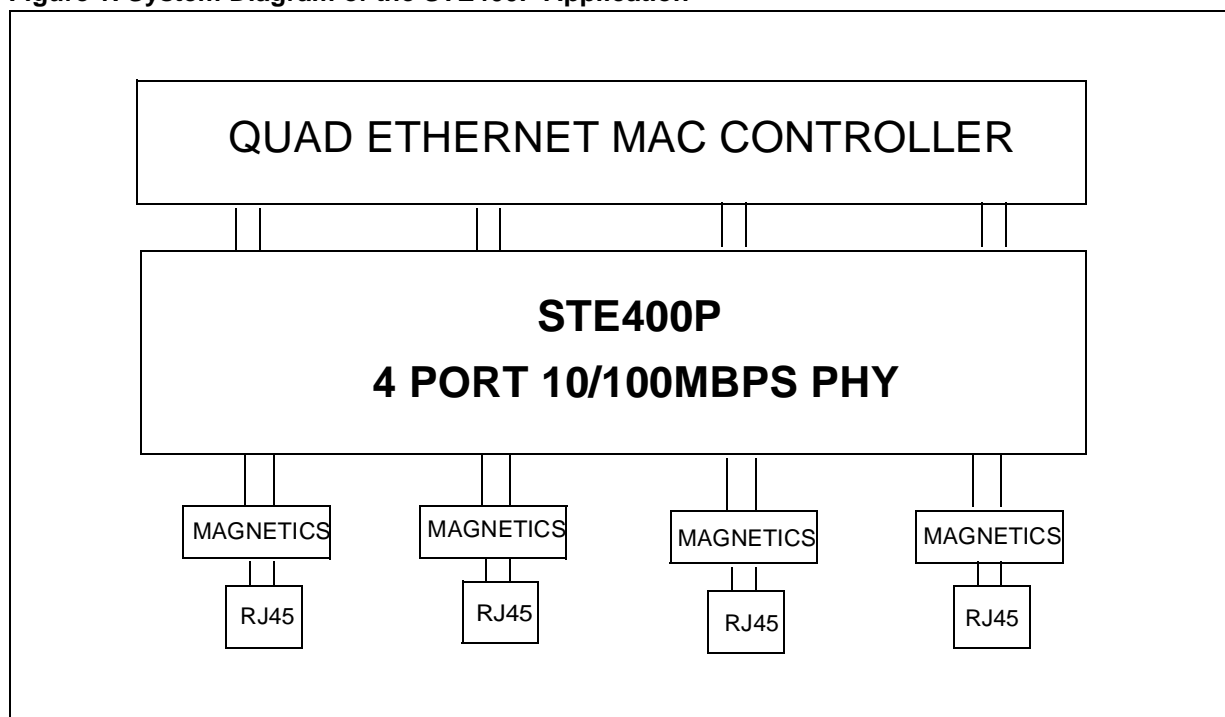

2.0 FEATURES

- Integrates the whole physical layer functions of the 100BASE-TX and 10BASE-T
- 3.3V low power operation
- The hardware control pins set the initial state of the STE400P at power-up
- Designed with a power down feature, which can save the power consumption significantly
- Can operate for either full duplex or half duplex network applications.

- MII interface
- Provides auto-negotiation, parallel detection or manual control for mode setting
- Provides MLT-3 transceiver with DC restoration for Base-line wander compensation
- Provides transmit wave-shaper, receive filters, and adaptive equalizer
- Provides loop-back modes for diagnostic testing
- Builds in Stream Cipher Scrambler/Descrambler and 4B/5B encoder/decoder
- Supports external transmit transformer with turn ratio 1.41:1
- Supports external receive transformer with turn ratio 1:1

3.0 DESIGN AND LAYOUT GUIDELINES

3.1 General Guidelines

- Verify that all components meet application requirements.
- Design in filters for the analog power circuits.
- Use bulk capacitors (10-22uF) between the power and ground planes to minimize switching noise, particularly near high-speed busses (>25 MHz).
- Use an ample supply of 0.1uF decoupling capacitors to reduce high-frequency noise on the power and ground planes.
- Use a single analog power and ground plane for multiple devices. Keep ferrite bead currents under 65% of the rated load
- Avoid breaks in the ground plane, especially in areas where it is shielding high-frequency signals.
- Keep power and ground noise levels below 50mV
- Keep high-speed signals out of the area between STE400P and the magnetics
- Ensure that the power supply is rated for the load and that output ripple is minimal (<50mV)
- Route high-speed signals next to a continuous, unbroken ground plane.
- Provide impedance matching on long traces to prevent reflections.
- Do not route any digital signals between the STE400P and the RJ-45 connectors at the edge of the board
- It is recommended to fill in unused areas of the signal planes with solid copper and attach them with vias to a Vcc or ground plane that is not located adjacent to the signal layer.

3.2 Differential Signal Layout Guidelines

- Route differential pairs close together and away from everything else
- Keep both traces of each differential pair as close to the same length as possible.
- Avoid vias and layer changes
- Keep transmit and receive pairs away from each other. Run orthogonally, or separate with a ground plane layer.

3.3 Power and Ground

In order to obtain high speed communications design, the power and ground planes may be conceptually divided into three regions (the analog and digital power planes and the signal ground plane)

The analog power region extends from the magnetics back to the STE400P, whereas the digital power region

extends from the MII interfaces of the STE400P through the rest of the board. Only components and signals pertaining to the particular interface should be placed or routed through each respective region. The digital section supplies power to the digital V_{cc}/i pin and to the external components. The analog section supplies power to V_{cca} pins of the STE400P.

The signal ground region is one continuous, unbroken plane that extends from the magnetics through the rest of the board. The signal ground plane may be combined with chassis ground or isolated from it. If the ground planes are combined, an isolation area is not required. When laying out ground planes, special care must be taken to avoid creating loop antenna effect. Some guidelines are as follows-

- Run all ground plane as solid square or rectangular regions
- Avoid creating loops with ground planes around other planes

3.4 Recommendations

The following recommendations apply to design and layout of the power and ground planes and will prevent the most common signal and noise issues.

- Divide the V_{cc} plane into two sections - analog and digital. The break between the planes should run under the device.
- When dividing the V_{cc} plane, it is not necessary to add extra layers to the board. Simply create moats or cutout regions in existing layers.
- Place a high-frequency bypass cap (0.1 μ F) near each analog V_{cc} pin
- Join the digital and analog sections at one or more points by ferric beads. Ensure that the maximum current rating of the bead is at least 150% of the nominal current that is expected to flow through it. (250mA per STE400P)
- Place a bulk capacitor (22 μ F) on each side of each ferrite bead to stop switching noise from travelling through the ferrite.

For designs with multiple STE400P's, it is acceptable to supply all from one analog V_{cc} plane. This plane can be joined to the digital V_{cc} plane at multiple points, with a ferrite bead at each one.

4.0 TWISTED PAIR INTERFACE

4.1 Transmit Interface Circuitry

Figure 2 shows a typical transmit interface circuitry. Current is sourced by the AV_{ddt} output to the centertap of the primary side of the winding. Current flows from the centertap to TX+ and TX-. Other components are as follows:

- The STE400P features a Controlled Impedance Device output for the transmit section. The output impedance of the transmit section of the STE400P is synthesized inside the device to provide impedance matching to the line, which has a nominal impedance of 100 ohm. Consequently, no external 50 ohm impedance matching resistors are required by the STE400P TX+ and TX- outputs.
- C1 shunts any common-mode energy present in the output to ground.
- The magnetics consists of the main winding and a common-mode choke.
- The common-mode choke stops common mode energy from reaching the line. It works together with capacitor C1 to direct common-mode energy away from the line.

Figure 2. Transmit Interface Circuitry

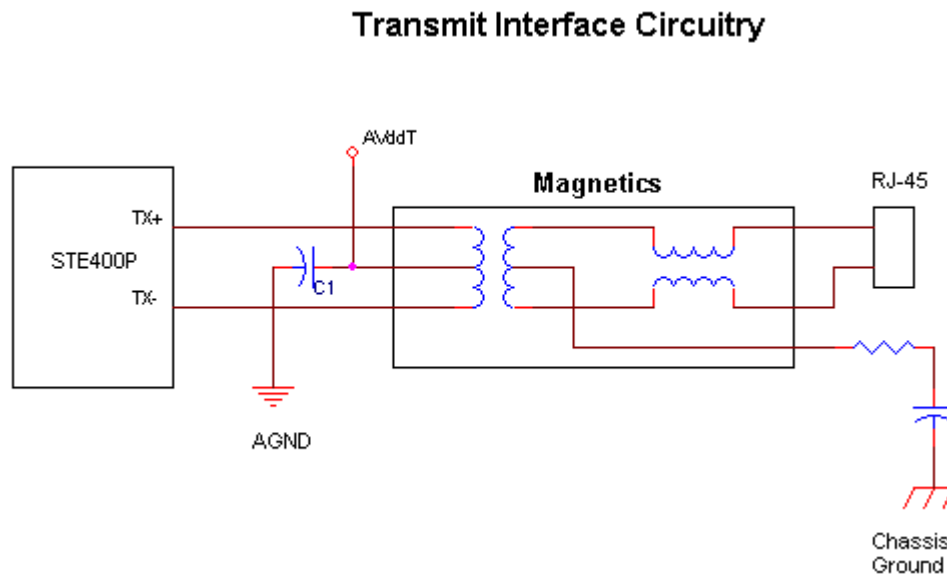

4.2 Receive Termination Circuitry

The receive termination circuit as shown in Figure 3 is a simple 100 ohm, 1% resistor across the RX+/RX- pair. The receive circuit consists of magnetics, which include a main winding and a common-mode choke, and termination resistance to match the line impedance. The common-mode choke can be located on either the primary or secondary side of the winding. Some vendors place the receive common-mode choke on the line-side (primary) of the main winding while others place it on the device side (secondary). Either location is acceptable.

Figure 3. Receive Interface Circuitry

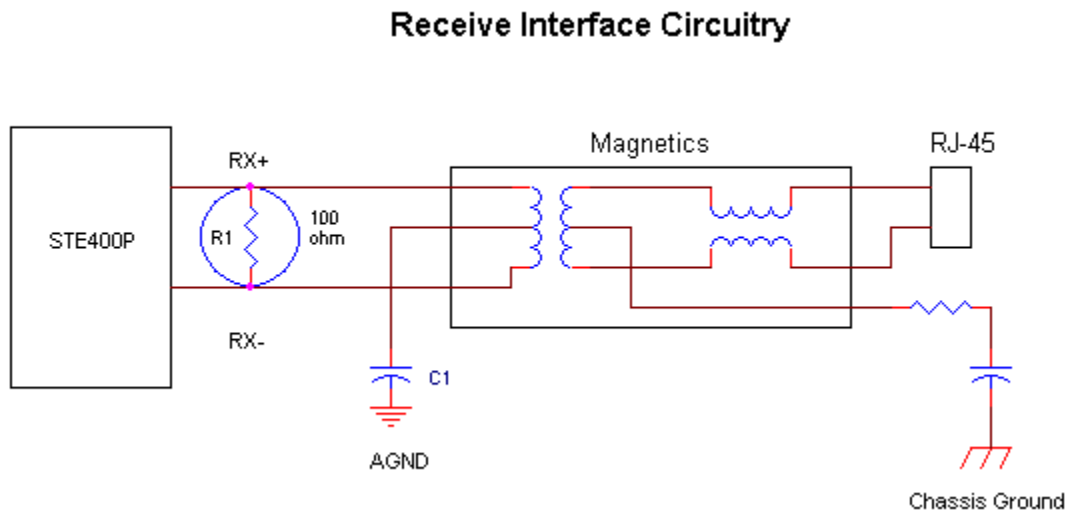

4.3 Suggested Circuitry

ST recommends a standard termination for the unused pairs on the twisted-pair interface as shown in Figure 4. The termination basically looks like a 100 ohm load, matched to the line, which is by passed to chassis ground. This termination is added for robustness and noise reduction.

Figure 4. Suggested Termination Circuit

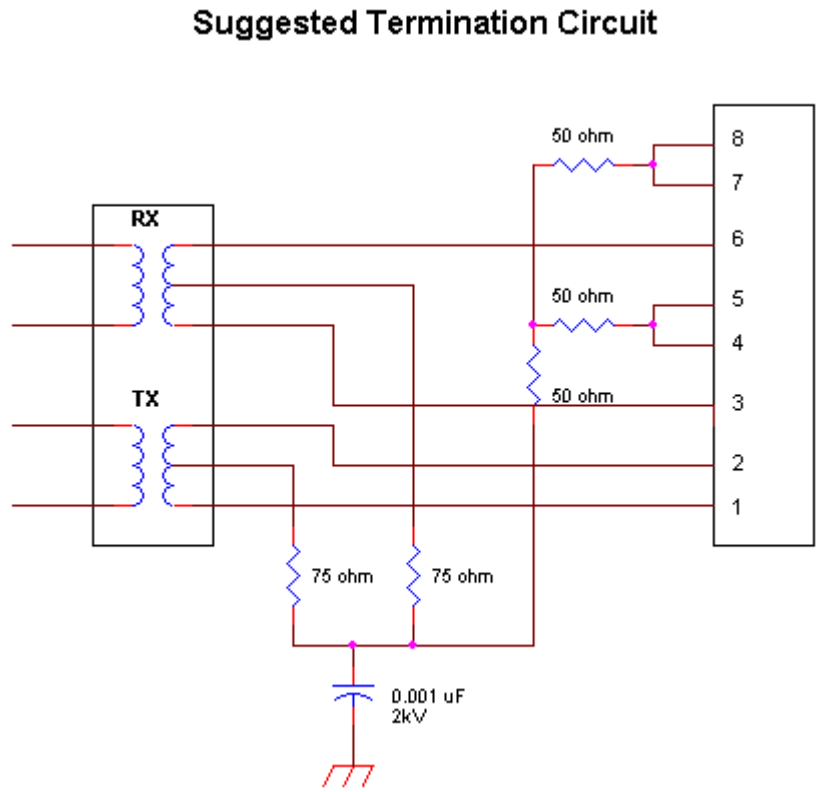

5.0 CRYSTAL REQUIREMENTS

The following table shows the crystal specifications

Parameter	Units	Min	Max	Nom
Frequency	MHz	-	-	25.0
Frequency Stability	ppm	-	+_- 100	-

Table 1

6.0 LED PINS

The LED display, consists of four LEDs having the following characteristics:

- ✦ Speed LED: 100Mbps(on) or 10Mbps(off)
- ✦ Receive LED: Blinks at 10Hz when receiving, but not colliding
- ✦ Transmit LED: Blinks at 10Hz when transmitting, but not colliding
- ✦ Link LED: On when 100M or 10M link ok

7.0 TYPICAL APPLICATION

While the STE400P may be used in a variety of applications such as multi-port repeaters or switches, the application shown below gives a very simple way of evaluating and using the STE400P with minimum circuitry. (Refer to Bill of Materials in Table 2)

A typical application of the STE400P presented here would be in designing a Quad Fast Ethernet transceiver with a standard MII interface and a 10/100 Mbps twisted pair connector. (Refer to Fig. 5)

In this application,

- The STE400P connects to the industry standard 40-pin MII connector via 74LCX244 buffers controlled by DIP switches to select receive and transmit port.
- Dip Switches SW1 and SW2 select the Receive and transmit port, respectively, to which the receive and transmit MII data will be connected.
- Each port is connected to a RJ-45 jack via a standard Fast Ethernet transformer (1.414:1 TX and 1:1 RX ratio).
- Positions 1-3 of DIP switch, S1, are used to select the PHY address offset for all four ports. (More details on the PHY address is available on the STE400P datasheet)
- Positions 4-6 of DIP switch, S1, are used for determination of all of the pin-selectable options of the STE400P such as duplex mode, data rate and auto negotiation.
- Position 7 of DIP switch, S1, is used to enable a hardware reset of the device by directly controlling the STE400P reset pin.
- STE400P also supports the MII MDIO access to all of its internal registers for .
- LEDs are included to indicate status information such as speed, duplex mode, transmit and receive activity and link status.
- There are registers with 16 bits each supported for STE400P. Details on these registers are available in the STE400P datasheet.

7.1 Schematics and Bill of Materials

The schematics for the sample application for the STE400P can be found on the website at:

<http://www.st.com/stonline/prodpres/dedicate/connect/datacom/ste100p/ste100p.htm>

Following are the Bill of Materials for the STE400P sample application:

AN1375 APPLICATION NOTE

Bill of Materials

Item	Quantity	Reference	Part Description
1	21	C1,C2,C5,C13,C14,C18,C19, C21,C22,C25,C26,C28,C29, C32,C33,C35,C36,C39,C40, C42,C43,C44,C45,C46,C47, C48,C49,C50,C51	0.1UF ceramic capacitor 0603 SMD Panasonic ECJ-1VB1C104K
2	9	C3,C4,C6,C7,C8,C9,C10, C11,C12	22UF 2.5mm spacing thru hole cap Panasonic ECE-A1EKS220
3	1	C15	0.01UF
4	8	C16,C17,C23,C24,C30,C31, C37,C38	10PF ceramic capacitor 0603 SMD Panasonic ECU-V1H100DCV
5	4	C20,C27,C34,C41	0.001UF 0.20 spacing thru hole cap Panasonic ECQ-B2102
(All LEDs are 2.5mm spacing thru hole Lumex SSL-LX3044GD)			
6	1	D1	RcvLED2
7	1	D2	RcvLED3
8	2	D9,D3	RcvLED
9	1	D4	XmitLED3
10	1	D5	LnkLED2
11	1	D6	XmitLED2
12	1	D7	LnkLED3
13	2	D11,D8	XmitLED
14	2	D13,D10	LnkLED
15	2	D16,D12	Sp100LED
16	1	D14	Sp100LED2
17	1	D15	Sp100LED3
18	1	JP1	JUMPER 2X1_1
19	2	JP2,JP3	0.10 spacing jumper AMP 640452-2 JUMPER
20	4	J1,J2,J3,J4	0.10 spacing jumper AMP 640452-2 RJ45
21	4	L1,L2,L3,L4,L5	8 pin modular jack; AMP 555153-1 BEAD 27ohm 100MHz 0603 SMD Panasonic EXC-ML-16A270U
22	1	OSC1	25MHZ 14 DIP; CTS # MXO45T-25.000
23	8	R1,R2,R3,R4,R5,R6,R7,R8	10 K resistor 0603 SMD
24	6	R9,R10,R11,R12,R13,R43	0 ohm resistor 0603 SMD
25	16	R14,R15,R16,R17,R18,R19, R20,R21,R22,R23,R24,R25, R26,R27,R28,R29	330 resistor 0805 SMD
26	14	R30,R31,R32,R33,R34,R35, R36,R37,R38,R39,R40,R41, R44,R45	10K resistor 0603 SMD

27	1	R42	4.99K resistor
28	20	R46,R47,R49,R50,R54,R55, R56,R58,R59,R63,R64,R65, R67,R68,R72,R73,R74,R76, R77,R81	49.9 resistor 0603 SMD
29	4	R48,R57,R66,R75	0 ohm resistor
30	4	R51,R60,R69,R78	100 ohm resistor
31	8	R52,R53,R61,R62,R70,R71, R79,R80	75 ohm resistor 0603 SMD
32	2	SW1,SW2	SW DIP-4 8 pin DIP; C&K # BD04
33	1	S1	SW DIP-7 14 pin DIP; C&K # BD07
34	2	TP1,TP2	POGO_2 Straight Post .025 square
35	6	TP3,TP4,TP5,TP6,TP7,TP8	POGO Straight Post .025 square
36	8	U1,U2,U4,U7,U9,U10,U12, U13	74LCX244 20-SOP
37	1	U3	MII 40 DSUB .050 AMP 174218-2
38	3	U5,U8,U11	3.3VReg; SOT-223 LM2937IMP-3.3
39	1	U6	MII Test 2x10 0.10 header
40	1	U14	STE400P PQFP208 or Socket Yamaichi IC51-2084-1052
41	4	U15,U16,U17,U18	H1013 or H1033 transformer

NOTES:

1. Resistors R46, R47, R55, R56, R64, R65, R73, and R74 should not be installed when using the STE400P due to the CID output of the transmitter.
2. Capacitors C16, C17, C23, C24, C30, C31, C37, and C38 should not be installed when using the STE400P due to the CID output of the transmitter.
3. Transformers such as the Pulse Engineering H1013 or H1033 transformers with 1.414:1 ratio for the transmit winding should be used with the STE400P.

Information furnished is believed to be accurate and reliable. However, STMicroelectronics assumes no responsibility for the consequences of use of such information nor for any infringement of patents or other rights of third parties which may result from its use. No license is granted by implication or otherwise under any patent or patent rights of STMicroelectronics. Specifications mentioned in this publication are subject to change without notice. This publication supersedes and replaces all information previously supplied. STMicroelectronics products are not authorized for use as critical components in life support devices or systems without express written approval of STMicroelectronics.

The ST logo is a registered trademark of STMicroelectronics
© 2001 STMicroelectronics - All Rights Reserved

STMicroelectronics GROUP OF COMPANIES
Australia - Brazil - China - Finland - France - Germany - Hong Kong - India - Italy - Japan - Malaysia - Malta - Morocco - Singapore - Spain
- Sweden - Switzerland - United Kingdom - U.S.A.
<http://www.st.com>