

Silicon Piezoresistive Relative Pressure Sensor

**KPY 51-R
KPY 56-R**

Features

- Low pressure and temperature hysteresis
- Fast response
- High sensitivity and linearity
- Fatigue free monocrystalline silicon diaphragm giving high load cycle stability
- High long term stability
- Built in silicon temperature sensor
- Media compatible stainless housing

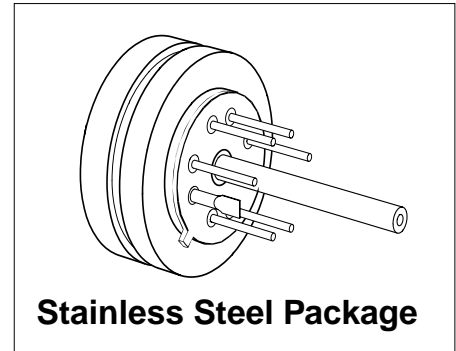

Type	Symbol	Pressure Range	Unit	Ordering Code
KPY 51-R	$P_0 \dots P_N$	0 ... 0.25	bar	Q62705-K174
KPY 52-R		0 ... 0.6		Q62705-K171
KPY 53-R		0 ... 1.6		Q62705-K176
KPY 54-R		0 ... 4		Q62705-K178
KPY 55-R		0 ... 10		Q62705-K180
KPY 56-R		0 ... 25		Q62705-K182

Pin Configuration

1	Capillary tube
2	+ V_{IN}
3	- V_{OUT}
4	Temperature sensor (typ. $R_{25} = 2 \text{ k}\Omega$)
5	Temperature sensor
6	- V_{IN}
7	+ V_{OUT}
8	Not connected

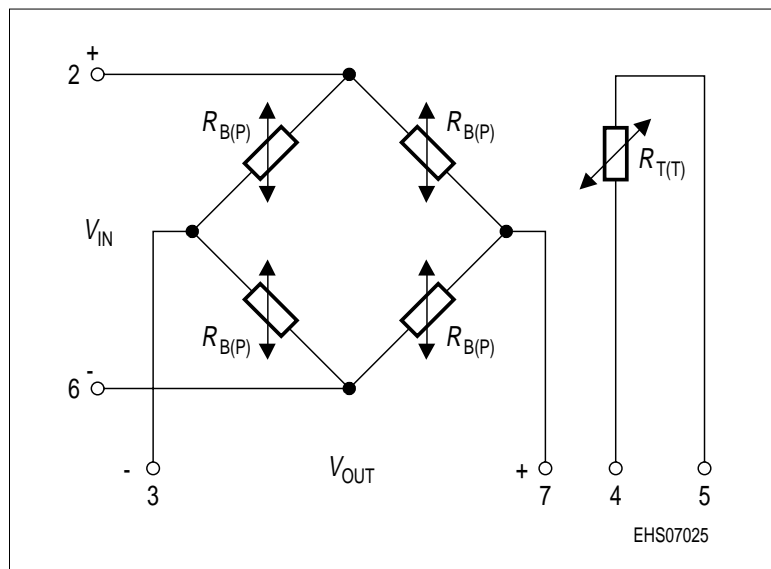

Absolute Maximum Ratings

Parameter	Symbol	Limit Values ¹⁾		Unit
		Frontside	Rearside	
Pressure overload KPY 51-R KPY 52-R KPY 53-R KPY 54-R KPY 55-R KPY 56-R	P_{MAX}	2 6 10 16 30 75	2 6 10 16 30 40	bar
Operating temperature range	T_A	– 40 ... + 125		°C
Storage temperature range	T_{stg}	– 50 ... + 130		°C
Supply voltage	V_{IN}	12		V

- 1) Frontside coupling applies pressure onto chip face.
Rearside coupling applies pressure through Kovar centre tube.

Electrical Characteristics

at $T_A = 25\text{ °C}$ and $V_{IN} = 5\text{ V}$, unless otherwise specified.

Parameter	Symbol	Limit Values			Unit
		min.	typ.	max.	
Bridge resistance	R_B	4	–	8	kΩ
Sensitivity KPY 51-R KPY 52-R KPY 53-R KPY 54-R KPY 55-R KPY 56-R	s	16.8 11.0 5.6 4.0 1.8 0.88	24.0 15.0 8.8 6.0 2.6 1.2	32.0 24.0 12.5 9.0 4.0 2.0	mV/ Vbar
Output voltage KPY 51-R KPY 52-R KPY 53-R KPY 54-R KPY 55-R KPY 56-R	V_{fin}	21 33 45 80 90 110	30 45 70 120 130 150	40 72 100 180 200 250	mV
Offset voltage $P = P_0$	V_0	– 25	–	+ 25	mV

Electrical Characteristics (cont'd)

at $T_A = 25\text{ °C}$ and $V_{IN} = 5\text{ V}$, unless otherwise specified.

Parameter	Symbol	Limit Values			Unit
		min.	typ.	max.	
Linearity error (Best fit straight line) $P_0 = P_0 \dots P_N$	F_L				% V_{fin}
KPY 51 ... 55-R		–	± 0.15	± 0.35	
KPY 56-R		–	± 0.15	–	
Pressure hysteresis $P_1 = P_0, P_2 = P_N, P_3 = P_0$	P_H				% V_{fin}
KPY 51 ... 56-R		–	± 0.1	–	

Electrical Characteristics

at $T_1 = 25\text{ °C}$, $T_2 = 80\text{ °C}$, $T_3 = 25\text{ °C}$ and $V_{IN} = 5\text{ V}$, unless otherwise specified.

Parameter	Symbol	Limit Values			Unit
		min.	typ.	max.	
Temperature coefficient of V_{fin}	$TC_{V_{fin}}$				% / K
KPY 51-R		– 0.20	–	– 0.09	
KPY 52-R		– 0.20	–	– 0.12	
KPY 53-R		– 0.20	–	– 0.13	
KPY 54-R		– 0.20	–	– 0.14	
KPY 55-R		– 0.20	–	– 0.15	
KPY 56-R		– 0.20	–	– 0.15	
Temperature coefficient of V_0	TC_{V_0}				% / K
KPY 51-R		– 0.03	–	+ 0.08	
KPY 52-R		– 0.03	–	+ 0.08	
KPY 53-R		– 0.03	–	+ 0.05	
KPY 54-R		– 0.03	–	+ 0.05	
KPY 55-R		– 0.03	–	+ 0.05	
KPY 56-R		– 0.03	–	+ 0.05	
Temperature coefficient of R_B	TC_{R_B}				% / K
KPY 51 ... 56-R		–	+ 0.095	–	
Temperature hysteresis of V_0 ; V_{fin}	TH				% v. V_{fin}
KPY 51 ... 56-R		–	± 0.2	–	

Package Outline

Stainless Steel Package

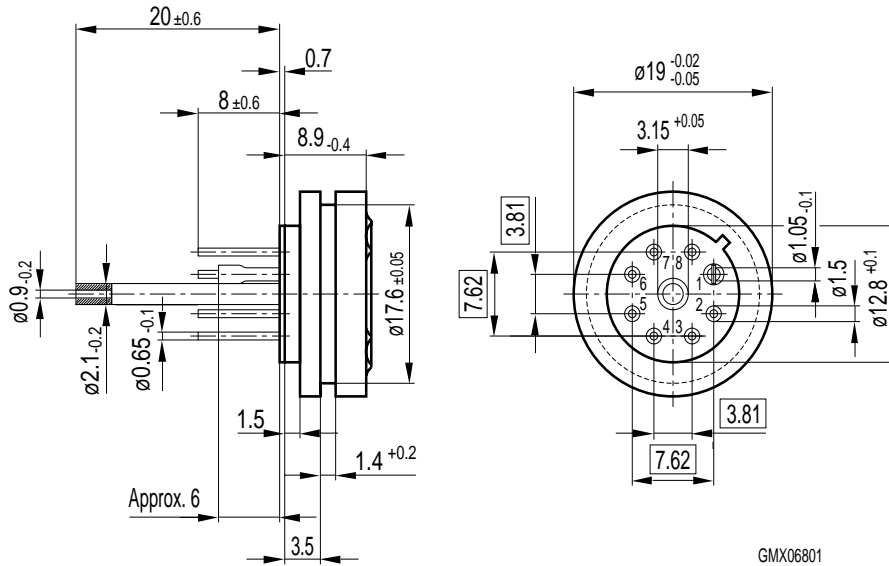

Weight 15.5 g

Sorts of Packing

Package outlines for tubes, trays etc. are contained in our Data Book "Package Information".

Dimensions in mm