

WIREWOUND TYPE COMMON MODE FILTER

W3 SERIES

1. PART NO. EXPRESSION :

W 3 F 9 0 0 - R D - 1 0
 (a)(b)(c) (d) (e)(f) (g)

- (a) Series code
- (b) Dimension code
- (c) Material code
- (d) Impedance code : 900 = 90Ω
- (e) R : Tape & Reel
- (f) Rated Current : D = 400mA
- (g) 10 : Lead Free

2. CONFIGURATION & DIMENSIONS :

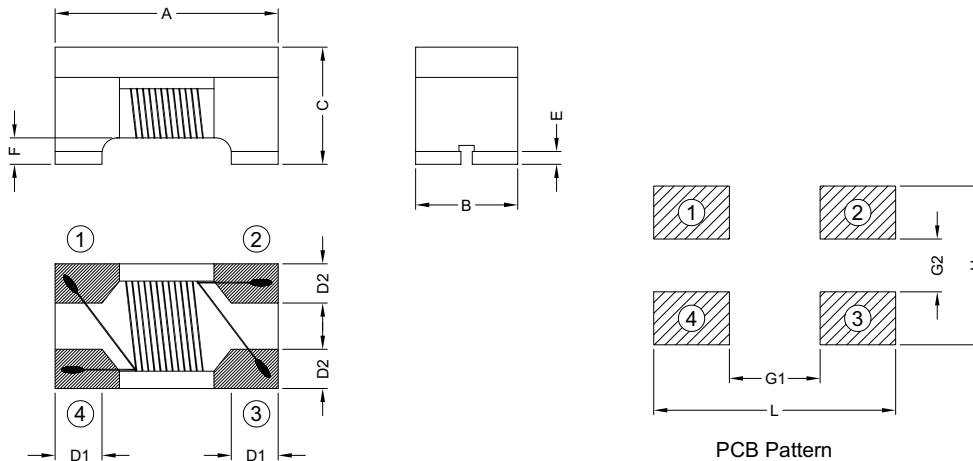

Unit:m/m

A	B	C	D1	D2	E	F	G1	G2	H	L
2.0±0.2	1.2±0.2	1.2±0.2	0.45 Typ.	0.40 Typ.	0.17 Typ.	0.27±0.05	1.10 Ref.	0.45 Ref.	1.25 Ref.	2.60 Ref.

3. SCHEMATIC :

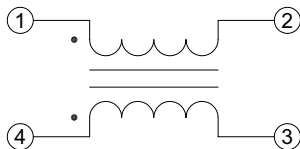

4. MATERIALS :

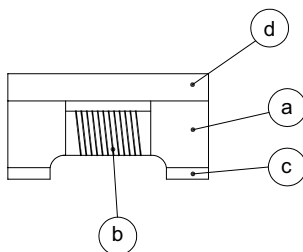

- (a) Core : Ferrite U Core
- (b) Wire : Enamelled Copper Wire
- (c) Terminal : Ag / Ni / Sn
- (d) Capsulate : Ferrite Cap



RoHS Compliant

NOTE : Specifications subject to change without notice. Please check our website for latest information.

14.04.2009

5. GENERAL SPECIFICATION :

- a) Operating temp. : -40°C to +85°C
- b) Storage temp. : -40°C to +85°C

6. ELECTRICAL CHARACTERISTICS :

Part No.	Common mode Impedance (Ω)	Test Frequency (MHz)	DCR (Ω) Max.	Rated Current (mA)	Rated Voltage (Vdc)	Withstand Voltage (Vdc)	IR (Ω) Min.
W3F900-RD-10	90±25%	100	0.30	400	50	125	10M
W3F121-RD-10	120±25%	100	0.15	400	50	125	10M
W3F161-RD-10	160±25%	100	0.35	350	50	125	10M
W3F221-RC-10	220±25%	100	0.40	300	50	125	10M
W3F371-RA-10	370±25%	100	0.50	100	50	125	10M

7. CHARACTERISTICS CURVES :

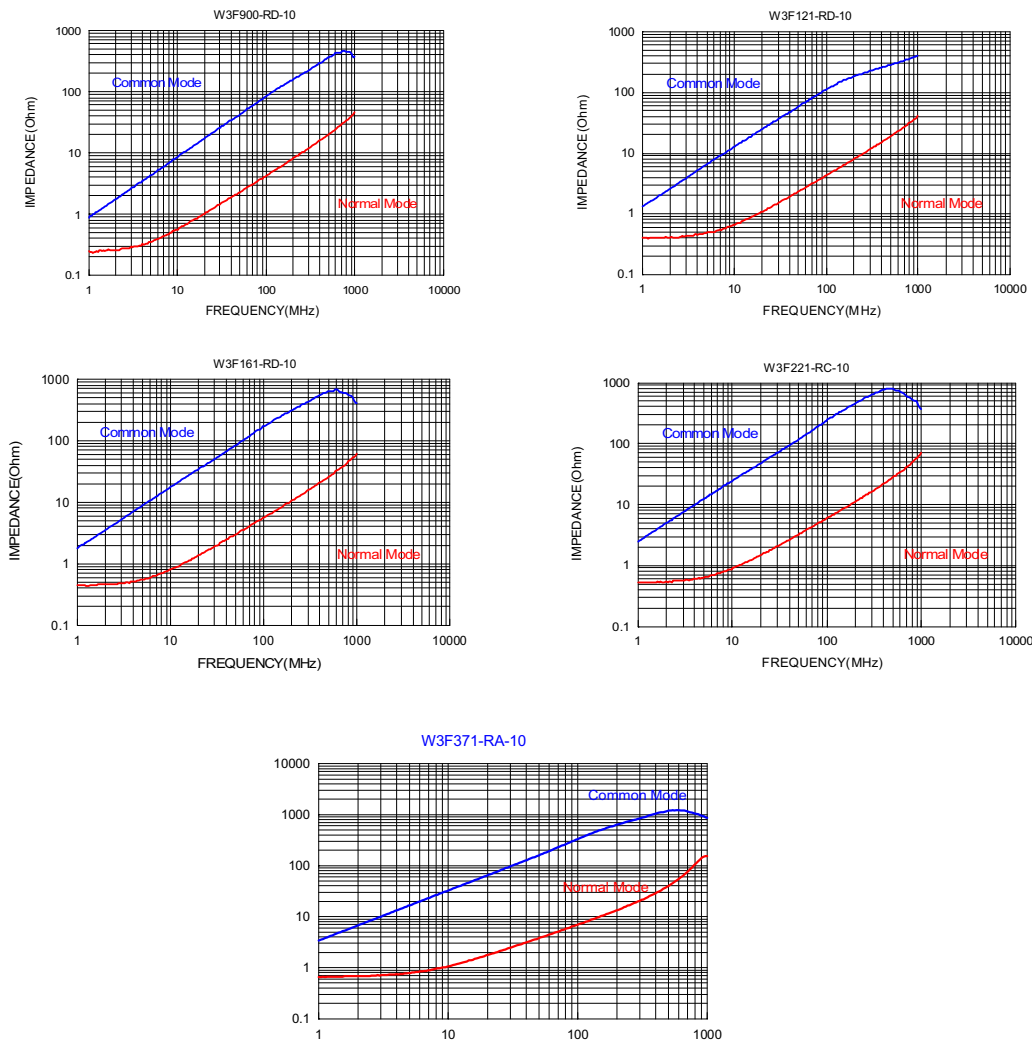

RoHS Compliant

NOTE : Specifications subject to change without notice. Please check our website for latest information.

14.04.2009



SUPERWORLD ELECTRONICS (S) PTE LTD

8. RELIABILITY & TEST CONDITION :

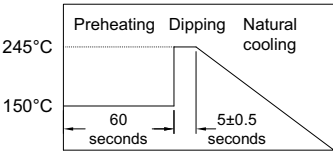
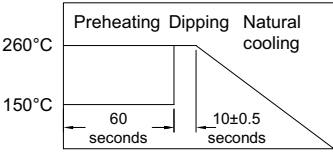
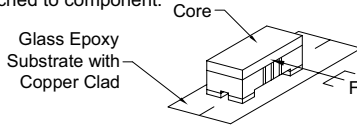
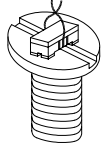
ITEM	PERFORMANCE	TEST CONDITION										
Electrical Characteristics Test												
Z (common mode)	Refer to standard electrical characteristics list	HP-4291A + HP-16092A										
DCR		HP-4338B										
I.R.		Zentech 702A (Ultra High Resistance Meter)										
Rated Current		Applied the current to coils the impedance change should be less than $\pm 25\%$ to initial value and temperature rise should not be more than 30°C.										
Operating Temperature	-40°C ~ +85°C											
Storage Temperature	-40°C ~ +85°C											
Temperature Rise Test	30°C max. (Δt)	1. Applied the allowed DC current. 2. Temperature measured by digital surface thermometer.										
Mechanical Performance Test												
Solderability Test	More than 90% of terminal electrode should be covered with solder.	 <p>After fluxing component shall be dipped in a melted solder bath at 245\pm5°C for 5 seconds.</p>										
Solder Heat Resistance	1. Components should have not evidence of electrical and mechanical damage. 2. Impedance : within $\pm 25\%$ of initial value.	 <p>Preheat : 150°C 60secs Solder : Sn-Ag3-Cu0.5 Solder temperature : 260\pm5°C Flux : rosin Dip time : 10\pm5 secs.</p>										
Component Adhesion (Push Test)	<table border="1"> <thead> <tr> <th>Size</th> <th>F (Kg)</th> </tr> </thead> <tbody> <tr> <td>W4 (S)</td> <td>0.8 (min.)</td> </tr> <tr> <td>W3 (S)</td> <td>0.5 (min.)</td> </tr> <tr> <td>W4 (N)</td> <td>0.8 (min.)</td> </tr> <tr> <td>W3 (N)</td> <td>0.5 (min.)</td> </tr> </tbody> </table>	Size	F (Kg)	W4 (S)	0.8 (min.)	W3 (S)	0.5 (min.)	W4 (N)	0.8 (min.)	W3 (N)	0.5 (min.)	<p>The device should be reflow solder (230\pm5°C for 10 secs.) to a tinned copper substrate. A dynamometer force gauge should be applied the side of the component. The device must withstand F(Kg) without failure of the termination attached to component.</p> 
Size	F (Kg)											
W4 (S)	0.8 (min.)											
W3 (S)	0.5 (min.)											
W4 (N)	0.8 (min.)											
W3 (N)	0.5 (min.)											
Component Adhesion (Pull Test)	<table border="1"> <thead> <tr> <th>Size</th> <th>F (Kg)</th> </tr> </thead> <tbody> <tr> <td>W4 (S)</td> <td>0.8 (min.)</td> </tr> <tr> <td>W3 (S)</td> <td>0.5 (min.)</td> </tr> <tr> <td>W4 (N)</td> <td>0.8 (min.)</td> </tr> <tr> <td>W3 (N)</td> <td>0.5 (min.)</td> </tr> </tbody> </table>	Size	F (Kg)	W4 (S)	0.8 (min.)	W3 (S)	0.5 (min.)	W4 (N)	0.8 (min.)	W3 (N)	0.5 (min.)	<p>1. Insert 10cm wire into the remaining open eye bend, the ends of even wire lengths upward and wind together. 2. Terminal shall not be remarkably damaged.</p> 
Size	F (Kg)											
W4 (S)	0.8 (min.)											
W3 (S)	0.5 (min.)											
W4 (N)	0.8 (min.)											
W3 (N)	0.5 (min.)											

NOTE : Specifications subject to change without notice. Please check our website for latest information.

14.04.2009



8. RELIABILITY & TEST CONDITION :

ITEM	PERFORMANCE	TEST CONDITION															
Reliability Test																	
High Temperature Life Test	1. Appearance : No damage. 2. Impedance : within $\pm 25\%$ of initial value. No disconnection or short circuit.	Temperature : $85\pm 5^{\circ}\text{C}$ Time : $500\pm 12\text{hr}$. Recovery : 4 to 24hrs of recovery under the standard condition after the removal from test chamber.															
Low Temperature Life Test		Temperature : $-40\pm 5^{\circ}\text{C}$ Time : $500\pm 12\text{hr}$. Recovery : 4 to 24hrs of recovery under the standard condition after the removal from test chamber.															
Thermal Shock		Conditions of 1 cycle <table border="1" style="margin-left: 20px;"> <thead> <tr> <th>Step</th> <th>Temperature ($^{\circ}\text{C}$)</th> <th>Times (min.)</th> </tr> </thead> <tbody> <tr> <td>1</td> <td>-40 ± 3</td> <td>30 ± 3</td> </tr> <tr> <td>2</td> <td>Room Temperature</td> <td>Within 3</td> </tr> <tr> <td>3</td> <td>85 ± 3</td> <td>30 ± 3</td> </tr> <tr> <td>4</td> <td>Room Temperature</td> <td>Within 3</td> </tr> </tbody> </table> Conditions of 1 cycle Total : 10 cycle Recovery : 4 to 24hrs of recovery under the standard condition after the removal from test chamber.	Step	Temperature ($^{\circ}\text{C}$)	Times (min.)	1	-40 ± 3	30 ± 3	2	Room Temperature	Within 3	3	85 ± 3	30 ± 3	4	Room Temperature	Within 3
Step		Temperature ($^{\circ}\text{C}$)	Times (min.)														
1	-40 ± 3	30 ± 3															
2	Room Temperature	Within 3															
3	85 ± 3	30 ± 3															
4	Room Temperature	Within 3															
Humidity Resistance	Temperature : $40\pm 5^{\circ}\text{C}$ Humidity : 90 to 95% Applied current : Rated current Time : $500\pm 12\text{hr}$ Recovery : 4 to 24hrs of recovery under the standard condition after the removal from test chamber.																
Random Vibration Test	Appearance : Cracking, shipping and any other defects harmful to the characteristics should not be allowed. Impedance: within $\pm 30\%$	Frequency : 10-55-10Hz for 1 min. Amplitude : 1.52mm Directions & times : X, Y, Z directions for 2 hours. A period of 2 hours in each of 3 mutually perpendicular directions (Total 6 hours).															



RoHS Compliant

NOTE : Specifications subject to change without notice. Please check our website for latest information.

14.04.2009



SUPERWORLD ELECTRONICS (S) PTE LTD

PG. 4

9. SOLDERING AND MOUNTING :

9-1. Recommended PC Board Pattern

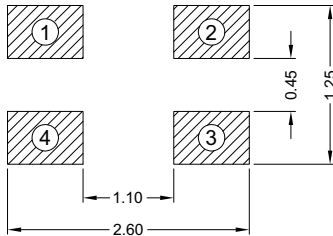

PC board should be designed so that products are not sufficient under mechanical stress as warping the board. Products shall be positioned in the sideways direction against the mechanical stress to prevent failure.

9-2. Soldering

Mildly activated rosin fluxes are preferred. The minimum amount of solder can lead to damage from the stresses caused by the difference in coefficients of expansion between solder, chip and substrate. Our terminations are suitable for all wave and re-flow soldering systems. If hand soldering cannot be avoided, the preferred technique is the utilization of hot air soldering tools.

9-2.1 Solder Re-flow :

Recommended temperature profiles for re-flow soldering in Figure 1.

9-2.2 Soldering Iron (Figure 2) :

Products attachment with soldering iron is discouraged due to the inherent process control limitations. In the event that a soldering iron must be employed the following precautions are recommended.

Note :

- a) Preheat circuit and products to 150°C.
- b) 280°C tip temperature (max)
- c) Never contact the ceramic with the iron tip
- d) 1.0mm tip diameter (max)
- e) Use a 20 watt soldering iron with tip diameter of 1.0mm
- f) Limit soldering time to 3 secs.

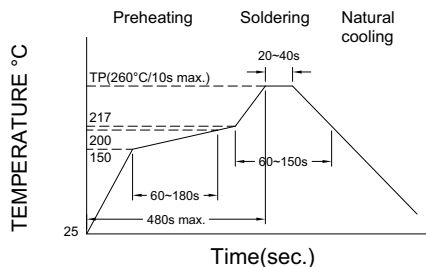

Figure 1. Re-flow Soldering

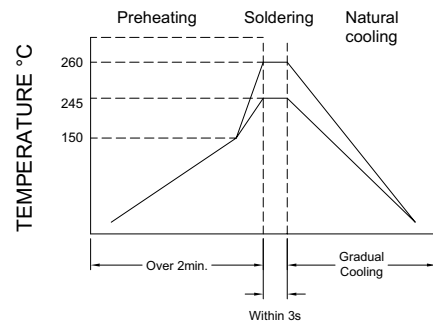

Figure 2. Wave Soldering

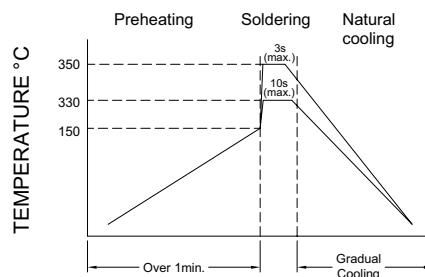

Figure 3. Hand Soldering



RoHS Compliant

NOTE : Specifications subject to change without notice. Please check our website for latest information.

14.04.2009



SUPERWORLD ELECTRONICS (S) PTE LTD

10. PACKAGING INFORMATION :

10-1. Reel Dimension

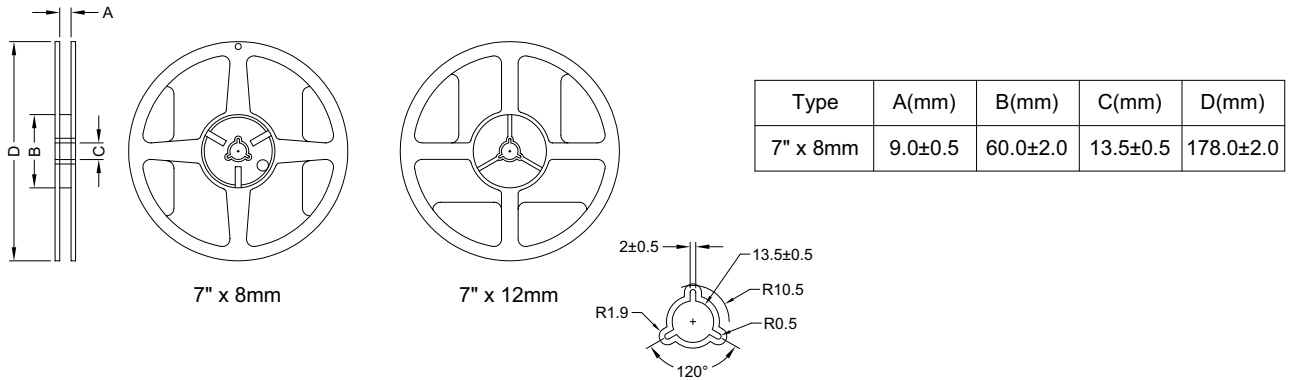

10-2 Tape Dimension / 8mm

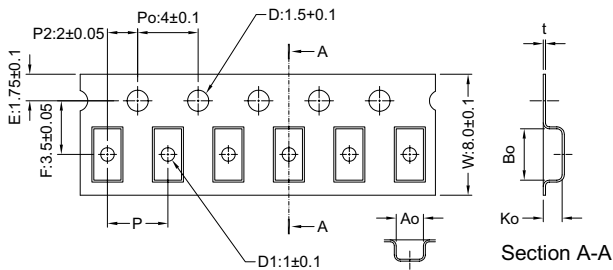

Series	Size	Bo(mm)	Ao(mm)	Ko(mm)	P(mm)	t(mm)
W3 (S)	201212	2.35±0.10	1.50±0.10	1.45±0.10	4.0±0.1	0.22±0.05
W4 (S)	321620	3.50±0.10	1.88±0.10	2.10±0.10	4.0±0.1	0.22±0.05
W3 (N)	201209	2.50±0.10	1.60±0.10	1.25±0.10	4.0±0.1	0.22±0.05
W4 (N)	321615	3.50±0.10	1.88±0.10	1.80±0.10	4.0±0.1	0.22±0.05

10-1. Reel Dimension

Chip Size	W3	W4
Chip / Reel	2000 / 3000	2000
Inner Box	10000 / 15000	10000
Middle Box	50000 / 75000	50000
Carton	100000 / 150000	100000



RoHS Compliant

NOTE : Specifications subject to change without notice. Please check our website for latest information.

14.04.2009



SUPERWORLD ELECTRONICS (S) PTE LTD