

ELECTRICAL CHARACTERISTICS @25°C

SCHEMATIC

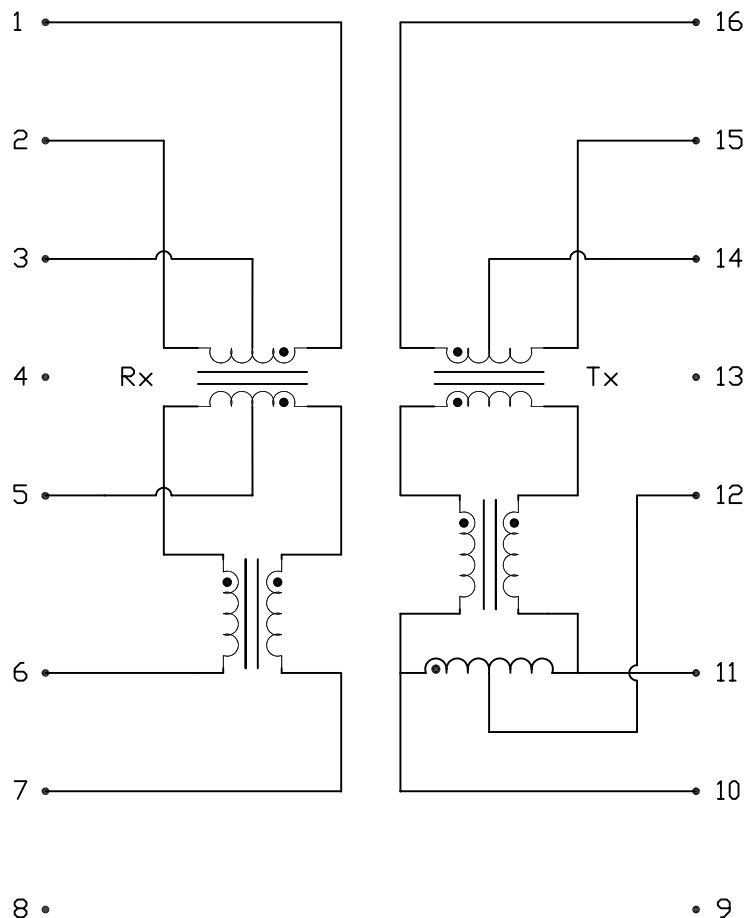

URNS RATIO

Rx (1-3-2) : (7-5-6)
Tx (16-14-15) : (10-12-11)

1CT : 1CT
1CT : 1.414CT

PHASING

1 TO 7 AND 16 TO 10
PER DOT CONVENTION

QCL

PIN (6 & 7), (10 & 11)

350uH MIN. AT 100kHz 100mV
WITH 8mA MIN. DC BIAS

INSERTION LOSS

1.2dB MAX, AT 100kHz TO 100

RETURN LOSS

MEASURED UNDER 100Ω
±15% ENVIRONMENT

| FREQ. (MHz) | 1 | 10 | 30 | 60 |
|-------------|----|----|----|----|
| dB MIN | 20 | 20 | 18 | 14 |

CMDR

1MHz
10MHz
50MHz
100MHz
200MHz

65dB MIN.
50dB MIN.
35dB MIN.
25dB MIN.
20dB MIN.

CROSSTALK

30dB MIN. AT 100kHz TO 100

COMMON TO COMMON MODE

1MHz
10MHz-50MHz
100MHz-200MHz

50dB MIN.
30dB MIN.
20dB MIN.

HIPOT

PER HAND-WORK-03

| ORIGINATED BY | DATE | TITLE | PART NO. / DRAWING NO. | STANDARD DIM. | [] METRIC DIM. AS REFEREN |
|---------------|----------|---|------------------------|-------------------|----------------------------|
| HD | 12-05-05 | 10/100BT MAGNETICS MODULE TX W/BST S558-5999-G9-F | X5585999G9-F | TOL. IN INCH | UNIT : INCH [mm] REV. : |
| DRAWN BY | DATE | | FILE NAME | .X .XX .XXX | SCALE : N/A SIZE : |
| DQ Chen | 12-05-05 | | X5585999G9FA.DWG | | ⊕ REV. : PAGE : |

THE INFORMATION CONTAINED HEREIN IS CONSIDERED "PROPRIETARY" TO BEL FUSE INC. AND SHALL NOT BE COPIED, REPRODUCED OR DISCLOSED WITHOUT THE WRITTEN APPROVAL OF BEL FUSE INC.

SUGGESTED PCB PAD LAYOUT

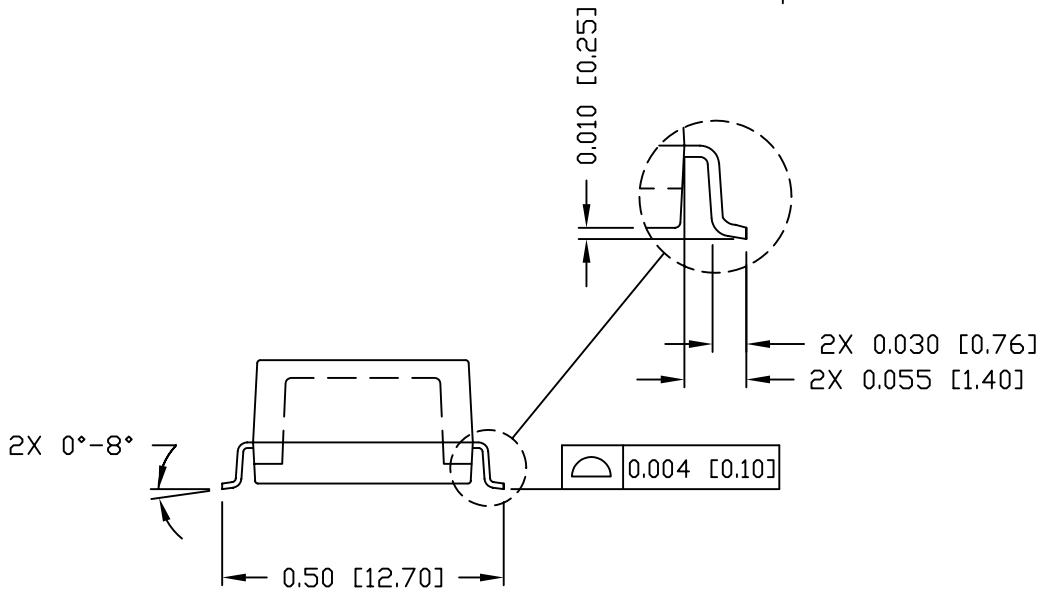
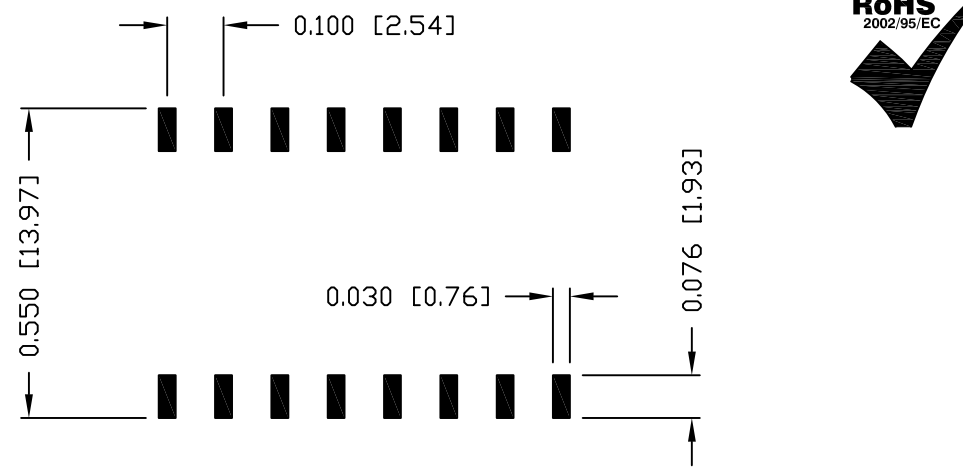
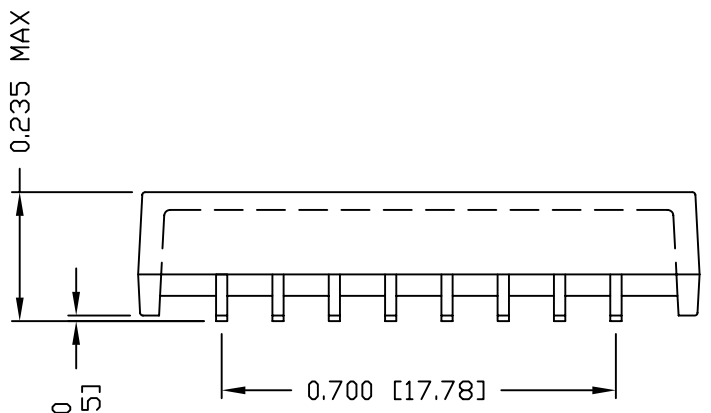
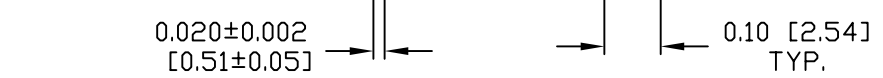
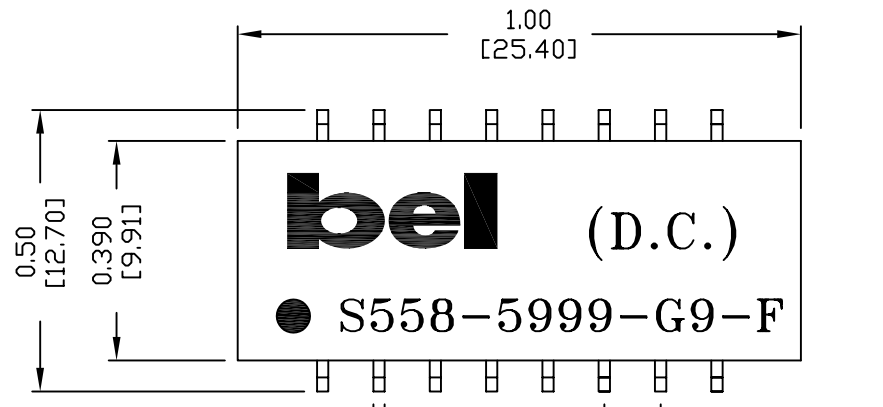

NOTES:

- STANDARD MARKING REFER TO DOC. HAND-WORK-04.
- PACKAGE CODE: "RNS001".

| | | | | | |
|---------------|----------|--------------------------------------|------------------------|----------------------------|------------------------------|
| ORIGINATED BY | DATE | TITLE | PART NO. / DRAWING NO. | STANDARD DIM. TOL. IN INCH | [] METRIC DIM. AS REFERENCE |
| HD | 12-05-05 | MECHANICAL DRAWING S558-5999-G9-F | X5585999G9-F | .X | UNIT : INCH [mm] |
| DRAWN BY | DATE | | FILE NAME | .XX ±0.01 | REV. : A |
| DQ Chen | 12-05-05 | | X5585999G9FA.DWG | .XXX ±0.005 | SCALE : N/A |
| | | | | | SIZE : A4 |
| | | | | | PAGE : 3 |

