



T-58-11-13
MC7900 Series

THREE-TERMINAL NEGATIVE VOLTAGE REGULATORS

The MC7900 Series of fixed output negative voltage regulators are intended as complements to the popular MC7800 Series devices. These negative regulators are available in the same seven-voltage options as the MC7800 devices. In addition, one extra voltage option commonly employed in MECL systems is also available in the negative MC7900 Series.

Available in fixed output voltage options from -5.0 to -24 volts, these regulators employ current limiting, thermal shut-down, and safe-area compensation — making them remarkably rugged under most operating conditions. With adequate heat-sinking they can deliver output currents in excess of 1.0 ampere.

- No External Components Required
- Internal Thermal Overload Protection
- Internal Short-Circuit Current Limiting
- Output Transistor Safe-Area Compensation
- Available in 2% Voltage Tolerance (See Ordering Information)

THREE-TERMINAL NEGATIVE FIXED VOLTAGE REGULATORS

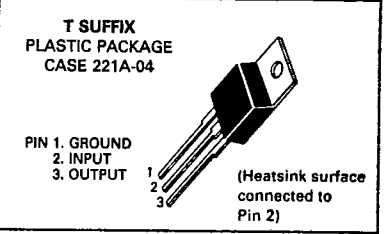
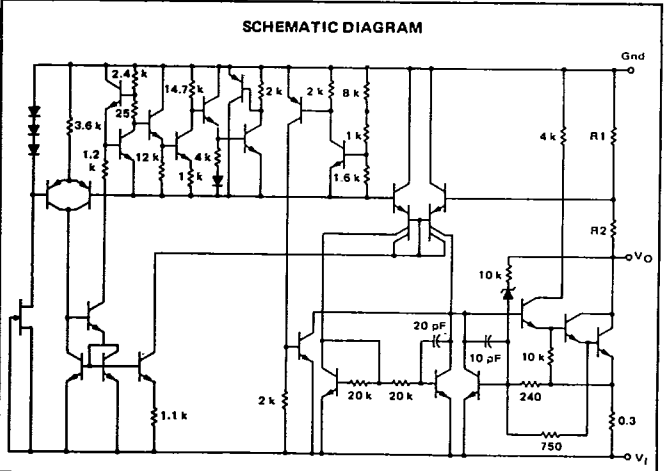
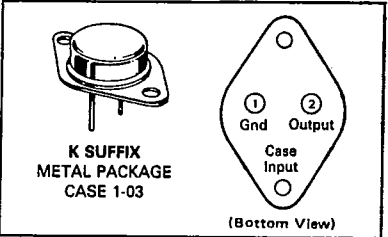

ORDERING INFORMATION

Device	Output Voltage Tolerance	Tested Operating Junction Temp. Range	Package
MC79XXCK	4%	T _J = 0°C to +125°C	Metal Power**
MC79XXACK*	2%		
MC79XXCT	4%	T _J = -40°C to +125°C	Plastic Power
MC79XXACT*	2%		
MC79XXBT#	4%		

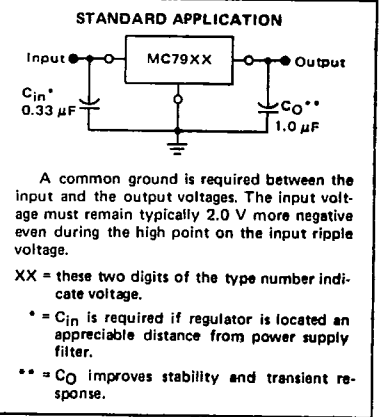

XX Indicates nominal voltage.
*2% output voltage tolerance available in 5, 12 and 15 volt devices.
**Metal power package available in 5, 12 and 15 volt devices.
#Automotive temperature range selections are available with special test conditions and additional tests in 5, 12 and 15 volt devices. Contact your local Motorola sales office for information.

DEVICE TYPE/NOMINAL OUTPUT VOLTAGE

MC7905	5.0 Volts	MC7912	12 Volts
MC7905.2	5.2 Volts	MC7915	15 Volts
MC7906	6.0 Volts	MC7918	18 Volts
MC7908	8.0 Volts	MC7924	24 Volts

MC7900 Series

T-58-11-13

MAXIMUM RATINGS ($T_A = +25^\circ\text{C}$ unless otherwise noted.)

Rating	Symbol	Value	Unit
Input Voltage ($-5.0\text{ V} \geq V_O \geq -18\text{ V}$) (24 V)	V_I	-35 -40	Vdc
Power Dissipation Plastic Package $T_A = +25^\circ\text{C}$ Derate above $T_A = +25^\circ\text{C}$	P_D $1/R_{\theta JA}$	Internally Limited 15.4	Watts mW/ $^\circ\text{C}$
$T_C = +25^\circ\text{C}$ Derate above $T_C = +95^\circ\text{C}$ (See Figure 1)	P_D $1/R_{\theta JC}$	Internally Limited 200	Watts mW/ $^\circ\text{C}$
Metal Package $T_A = +25^\circ\text{C}$ Derate above $T_A = +25^\circ\text{C}$	P_D $1/R_{\theta JA}$	Internally Limited 22.2	Watts mW/ $^\circ\text{C}$
$T_C = +25^\circ\text{C}$ Derate above $T_C = +65^\circ\text{C}$	P_D $1/R_{\theta JC}$	Internally Limited 182	Watts mW/ $^\circ\text{C}$
Storage Junction Temperature Range	T_{stg}	-65 to +150	$^\circ\text{C}$
Junction Temperature Range	T_J	0 to +150	$^\circ\text{C}$

THERMAL CHARACTERISTICS

Characteristic	Symbol	Max	Unit
Thermal Resistance, Junction to Ambient — Plastic Package — Metal Package	$R_{\theta JA}$	65 45	$^\circ\text{C}/\text{W}$
Thermal Resistance, Junction to Case — Plastic Package — Metal Package	$R_{\theta JC}$	5.0 5.5	$^\circ\text{C}/\text{W}$

MC7905C ELECTRICAL CHARACTERISTICS ($V_I = -10\text{ V}$, $I_O = 500\text{ mA}$, $0^\circ\text{C} < T_J < +125^\circ\text{C}$ unless otherwise noted.)

Characteristic	Symbol	Min	Typ	Max	Unit
Output Voltage ($T_J = +25^\circ\text{C}$)	V_O	-4.8	-5.0	-5.2	Vdc
Line Regulation (Note 1) ($T_J = +25^\circ\text{C}$, $I_O = 100\text{ mA}$) $-7.0\text{ Vdc} \geq V_I \geq -25\text{ Vdc}$ $-8.0\text{ Vdc} \geq V_I \geq -12\text{ Vdc}$	Reg_{line}	— —	7.0 2.0	50 25	mV
($T_J = +25^\circ\text{C}$, $I_O = 500\text{ mA}$) $-7.0\text{ Vdc} \geq V_I \geq -25\text{ Vdc}$ $-8.0\text{ Vdc} \geq V_I \geq -12\text{ Vdc}$		— —	35 8.0	100 50	
Load Regulation ($T_J = +25^\circ\text{C}$) (Note 1) $5.0\text{ mA} \leq I_O \leq 1.5\text{ A}$ $250\text{ mA} \leq I_O \leq 750\text{ mA}$	Reg_{load}	— —	11 4.0	100 50	mV
Output Voltage $-7.0\text{ Vdc} \geq V_I \geq -20\text{ Vdc}$, $5.0\text{ mA} \leq I_O \leq 1.0\text{ A}$, $P \leq 15\text{ W}$	V_O	-4.75	—	-5.25	Vdc
Input Bias Current ($T_J = +25^\circ\text{C}$)	I_{IB}	—	4.3	8.0	mA
Input Bias Current Change $-7.0\text{ Vdc} \geq V_I \geq -25\text{ Vdc}$ $5.0\text{ mA} \leq I_O \leq 1.5\text{ A}$	ΔI_{IB}	— —	— —	1.3 0.5	mA
Output Noise Voltage ($T_A = +25^\circ\text{C}$, $10\text{ Hz} \leq f \leq 100\text{ kHz}$)	e_{on}	—	40	—	μV
Ripple Rejection ($I_O = 20\text{ mA}$, $f = 120\text{ Hz}$)	RR	—	70	—	dB
Dropout Voltage $I_O = 1.0\text{ A}$, $T_J = +25^\circ\text{C}$	$V_I - V_O$	—	2.0	—	Vdc
Average Temperature Coefficient of Output Voltage $I_O = 5.0\text{ mA}$, $0^\circ\text{C} \leq T_J \leq +125^\circ\text{C}$	$\Delta V_O / \Delta T$	—	-1.0	—	mV/ $^\circ\text{C}$

Note:

1. Load and line regulation are specified at constant junction temperature. Changes in V_O due to heating effects must be taken into account separately. Pulse testing with low duty cycle is used.

MC7900 Series

T-58-11-13

MC7905AC ELECTRICAL CHARACTERISTICS ($V_I = -10\text{ V}$, $I_O = 500\text{ mA}$, $0^\circ\text{C} < T_J < +125^\circ\text{C}$ unless otherwise noted.)

Characteristic	Symbol	Min	Typ	Max	Unit
Output Voltage ($T_J = +25^\circ\text{C}$)	V_O	-4.9	-5.0	-5.1	Vdc
Line Regulation (Note 1) -8.0 Vdc $\geq V_I \geq -12\text{ Vdc}$; $I_O = 1.0\text{ A}$, $T_J = 25^\circ\text{C}$ -8.0 Vdc $\geq V_I \geq -12\text{ Vdc}$; $I_O = 1.0\text{ A}$ -7.5 Vdc $\geq V_I \geq -25\text{ Vdc}$; $I_O = 500\text{ mA}$ -7.0 Vdc $\geq V_I \geq -20\text{ Vdc}$; $I_O = 1.0\text{ A}$, $T_J = +25^\circ\text{C}$	Regline	—	2.0 7.0 7.0 6.0	25 50 50 50	mV
Load Regulation (Note 1) 5.0 mA $\leq I_O \leq 1.5\text{ A}$, $T_J = +25^\circ\text{C}$ 250 mA $\leq I_O \leq 750\text{ mA}$ 5.0 mA $\leq I_O \leq 1.0\text{ A}$	Regload	—	11 4.0 9.0	100 50 100	mV
Output Voltage -7.5 Vdc $\geq V_I \geq -20\text{ Vdc}$, 5.0 mA $\leq I_O \leq 1.0\text{ A}$, $P \leq 15\text{ W}$	V_O	-4.80	—	-5.20	Vdc
Input Bias Current	I_{IB}	—	4.4	8.0	mA
Input Bias Current Change -7.5 Vdc $\geq V_I \geq -25\text{ Vdc}$ 5.0 mA $\leq I_O \leq 1.0\text{ A}$ 5.0 mA $\leq I_O \leq 1.5\text{ A}$, $T_J = 25^\circ\text{C}$	ΔI_{IB}	—	—	1.3 0.5 0.5	mA
Output Noise Voltage ($T_A = +25^\circ\text{C}$, 10 Hz $\leq f \leq 100\text{ kHz}$)	e_{on}	—	40	—	μV
Ripple Rejection ($I_O = 20\text{ mA}$, $f = 120\text{ Hz}$)	RR	—	70	—	dB
Dropout Voltage $I_O = 1.0\text{ A}$, $T_J = +25^\circ\text{C}$	$V_I - V_O$	—	2.0	—	Vdc
Average Temperature Coefficient of Output Voltage $I_O = 5.0\text{ mA}$, $0^\circ\text{C} \leq T_J \leq +125^\circ\text{C}$	$\Delta V_O / \Delta T$	—	-1.0	—	mV/ $^\circ\text{C}$

MC7905.2C ELECTRICAL CHARACTERISTICS ($V_I = -10\text{ V}$, $I_O = 500\text{ mA}$, $0^\circ\text{C} < T_J < +125^\circ\text{C}$ unless otherwise noted.)

Characteristic	Symbol	Min	Typ	Max	Unit
Output Voltage ($T_J = +25^\circ\text{C}$)	V_O	-5.0	-5.2	-5.4	Vdc
Line Regulation (Note 1) ($T_J = +25^\circ\text{C}$, $I_O = 100\text{ mA}$) -7.2 Vdc $\geq V_I \geq -25\text{ Vdc}$ -8.0 Vdc $\geq V_I \geq -12\text{ Vdc}$ ($T_J = +25^\circ\text{C}$, $I_O = 500\text{ mA}$) -7.2 Vdc $\geq V_I \geq -25\text{ Vdc}$ -8.0 Vdc $\geq V_I \geq -12\text{ Vdc}$	Regline	—	8.0 2.2 37 8.5	52 27 105 52	mV
Load Regulation ($T_J = +25^\circ\text{C}$) (Note 1) 5.0 mA $\leq I_O \leq 1.5\text{ A}$ 250 mA $\leq I_O \leq 750\text{ mA}$	Regload	—	12 4.5	105 52	mV
Output Voltage -7.2 Vdc $\geq V_I \geq -20\text{ Vdc}$, 5.0 mA $\leq I_O \leq 1.0\text{ A}$, $P \leq 15\text{ W}$	V_O	-4.95	—	-5.45	Vdc
Input Bias Current ($T_J = +25^\circ\text{C}$)	I_{IB}	—	4.3	8.0	mA
Input Bias Current Change -7.2 Vdc $\geq V_I \geq -25\text{ Vdc}$ 5.0 mA $\leq I_O \leq 1.5\text{ A}$	ΔI_{IB}	—	—	1.3 0.5	mA
Output Noise Voltage ($T_A = +25^\circ\text{C}$, 10 Hz $\leq f \leq 100\text{ kHz}$)	e_{on}	—	42	—	μV
Ripple Rejection ($I_O = 20\text{ mA}$, $f = 120\text{ Hz}$)	RR	—	68	—	dB
Dropout Voltage $I_O = 1.0\text{ A}$, $T_J = +25^\circ\text{C}$	$V_I - V_O$	—	2.0	—	Vdc
Average Temperature Coefficient of Output Voltage $I_O = 5.0\text{ mA}$, $0^\circ\text{C} \leq T_J \leq +125^\circ\text{C}$	$\Delta V_O / \Delta T$	—	-1.0	—	mV/ $^\circ\text{C}$

Note:

1. Load and line regulation are specified at constant junction temperature. Changes in V_O due to heating effects must be taken into account separately. Pulse testing with low duty cycle is used.

MC7900 Series

T-58-11-13

MC7906C ELECTRICAL CHARACTERISTICS ($V_I = -11$ V, $I_O = 500$ mA, $0^\circ\text{C} < T_J < +125^\circ\text{C}$ unless otherwise noted.)

Characteristic	Symbol	Min	Typ	Max	Unit
Output Voltage ($T_J = +25^\circ\text{C}$)	V_O	-5.75	-6.0	-6.25	Vdc
Line Regulation (Note 1) ($T_J = +25^\circ\text{C}$, $I_O = 100$ mA) -8.0 Vdc $\geq V_I \geq -25$ Vdc -9.0 Vdc $\geq V_I \geq -13$ Vdc ($T_J = +25^\circ\text{C}$, $I_O = 500$ mA) -8.0 Vdc $\geq V_I \geq -25$ Vdc -9.0 Vdc $\geq V_I \geq -13$ Vdc	Regline	—	9.0 3.0	60 30	mV
Load Regulation ($T_J = +25^\circ\text{C}$) (Note 1) 5.0 mA $\leq I_O \leq 1.5$ A 250 mA $\leq I_O \leq 750$ mA	Regload	—	13 8.0	120 60	mV
Output Voltage -8.0 Vdc $\geq V_I \geq -21$ Vdc, 5.0 mA $\leq I_O \leq 1.0$ A, $P \leq 15$ W	V_O	-5.7	—	-6.3	Vdc
Input Bias Current ($T_J = +25^\circ\text{C}$)	I_{IB}	—	4.3	8.0	mA
Input Bias Current Change -8.0 Vdc $\geq V_I \geq -25$ Vdc 5.0 mA $\leq I_O \leq 1.5$ A	ΔI_{IB}	—	—	1.3 0.5	mA
Output Noise Voltage ($T_A = +25^\circ\text{C}$, 10 Hz $\leq f \leq 100$ kHz)	e_{on}	—	45	—	μV
Ripple Rejection ($I_O = 20$ mA, $f = 120$ Hz)	RR	—	65	—	dB
Dropout Voltage $I_O = 1.0$ A, $T_J = +25^\circ\text{C}$	$V_I - V_O$	—	2.0	—	Vdc
Average Temperature Coefficient of Output Voltage $I_O = 5.0$ mA, $0^\circ\text{C} \leq T_J \leq +125^\circ\text{C}$	$\Delta V_O / \Delta T$	—	-1.0	—	mV/ $^\circ\text{C}$

MC7908C ELECTRICAL CHARACTERISTICS ($V_I = -14$ V, $I_O = 500$ mA, $0^\circ\text{C} < T_J < +125^\circ\text{C}$ unless otherwise noted.)

Characteristic	Symbol	Min	Typ	Max	Unit
Output Voltage ($T_J = +25^\circ\text{C}$)	V_O	-7.7	-8.0	-8.3	Vdc
Line Regulation (Note 1) ($T_J = +25^\circ\text{C}$, $I_O = 100$ mA) -10.5 Vdc $\geq V_I \geq -25$ Vdc -11 Vdc $\geq V_I \geq -17$ Vdc ($T_J = +25^\circ\text{C}$, $I_O = 500$ mA) -10.5 Vdc $\geq V_I \geq -25$ Vdc -11 Vdc $\geq V_I \geq -17$ Vdc	Regline	—	12 5.0	80 40	mV
Load Regulation ($T_J = +25^\circ\text{C}$) (Note 1) 5.0 mA $\leq I_O \leq 1.5$ A 250 mA $\leq I_O \leq 750$ mA	Regload	—	26 9.0	160 80	mV
Output Voltage -10.5 Vdc $\geq V_I \geq -23$ Vdc, 5.0 mA $\leq I_O \leq 1.0$ A, $P \leq 15$ W	V_O	-7.6	—	-8.4	Vdc
Input Bias Current ($T_J = +25^\circ\text{C}$)	I_{IB}	—	4.3	8.0	mA
Input Bias Current Change -10.5 Vdc $\geq V_I \geq -25$ Vdc 5.0 mA $\leq I_O \leq 1.5$ A	ΔI_{IB}	—	—	1.0 0.5	mA
Output Noise Voltage ($T_A = +25^\circ\text{C}$, 10 Hz $\leq f \leq 100$ kHz)	e_{on}	—	52	—	μV
Ripple Rejection ($I_O = 20$ mA, $f = 120$ Hz)	RR	—	62	—	dB
Dropout Voltage $I_O = 1.0$ A, $T_J = +25^\circ\text{C}$	$V_I - V_O$	—	2.0	—	Vdc
Average Temperature Coefficient of Output Voltage $I_O = 5.0$ mA, $0^\circ\text{C} \leq T_J \leq +125^\circ\text{C}$	$\Delta V_O / \Delta T$	—	-1.0	—	mV/ $^\circ\text{C}$

Note:

1. Load and line regulation are specified at constant junction temperature. Changes in V_O due to heating effects must be taken into account separately. Pulse testing with low duty cycle is used.

MC7900 Series

T-58-11-13

MC7915C ELECTRICAL CHARACTERISTICS ($V_I = -23\text{ V}$, $I_O = 500\text{ mA}$, $0^\circ\text{C} < T_J < +125^\circ\text{C}$ unless otherwise noted.)

Characteristic	Symbol	Min	Typ	Max	Unit
Output Voltage ($T_J = +25^\circ\text{C}$)	V_O	-14.4	-15	-15.6	Vdc
Line Regulation (Note 1) ($T_J = +25^\circ\text{C}$, $I_O = 100\text{ mA}$) -17.5 Vdc $\geq V_I \geq -30\text{ Vdc}$ -20 Vdc $\geq V_I \geq -26\text{ Vdc}$ ($T_J = +25^\circ\text{C}$, $I_O = 500\text{ mA}$) -17.5 Vdc $\geq V_I \geq -30\text{ Vdc}$ -20 Vdc $\geq V_I \geq -26\text{ Vdc}$	Regline	—	14 6.0	150 75	mV
Load Regulation ($T_J = +25^\circ\text{C}$) (Note 1) 5.0 mA $\leq I_O \leq 1.5\text{ A}$ 250 mA $\leq I_O \leq 750\text{ mA}$	Regload	—	68 25	300 150	mV
Output Voltage -17.5 Vdc $\geq V_I \geq -30\text{ Vdc}$, 5.0 mA $\leq I_O \leq 1.0\text{ A}$, $P \leq 15\text{ W}$	V_O	-14.25	—	-15.75	Vdc
Input Bias Current ($T_J = +25^\circ\text{C}$)	I_{IB}	—	4.4	8.0	mA
Input Bias Current Change -17.5 Vdc $\geq V_I \geq -30\text{ Vdc}$ 5.0 mA $\leq I_O \leq 1.5\text{ A}$	ΔI_{IB}	—	—	1.0 0.5	mA
Output Noise Voltage ($T_A = +25^\circ\text{C}$, 10 Hz $\leq f \leq 100\text{ kHz}$)	e_{on}	—	90	—	μV
Ripple Rejection ($I_O = 20\text{ mA}$, $f = 120\text{ Hz}$)	RR	—	60	—	dB
Dropout Voltage $I_O = 1.0\text{ A}$, $T_J = +25^\circ\text{C}$	$V_I - V_O$	—	2.0	—	Vdc
Average Temperature Coefficient of Output Voltage $I_O = 5.0\text{ mA}$, $0^\circ\text{C} \leq T_J \leq +125^\circ\text{C}$	$\Delta V_O / \Delta T$	—	-1.0	—	mV/ $^\circ\text{C}$

MC7915AC ELECTRICAL CHARACTERISTICS ($V_I = -23\text{ V}$, $I_O = 500\text{ mA}$, $0^\circ\text{C} < T_J < +125^\circ\text{C}$ unless otherwise noted.)

Characteristic	Symbol	Min	Typ	Max	Unit
Output Voltage ($T_J = +25^\circ\text{C}$)	V_O	-14.7	-15	-15.3	Vdc
Line Regulation (Note 1) -20 Vdc $\geq V_I \geq -26\text{ Vdc}$; $I_O = 1.0\text{ A}$, $T_J = 25^\circ\text{C}$ -20 Vdc $\geq V_I \geq -26\text{ Vdc}$; $I_O = 1.0\text{ A}$, -17.9 Vdc $\geq V_I \geq -30\text{ Vdc}$; $I_O = 500\text{ mA}$ -17.5 Vdc $\geq V_I \geq -30\text{ Vdc}$; $I_O = 1.0\text{ A}$, $T_J = 25^\circ\text{C}$	Regline	—	27 57 57 57	75 150 150 150	mV
Load Regulation (Note 1) 5.0 mA $\leq I_O \leq 1.5\text{ A}$, $T_J = 25^\circ\text{C}$ 250 mA $\leq I_O \leq 750\text{ mA}$ 5.0 mA $\leq I_O \leq 1.0\text{ A}$	Regload	—	68 25 40	150 75 150	mV
Output Voltage -17.9 Vdc $\geq V_I \geq -30\text{ Vdc}$, 5.0 mA $\leq I_O \leq 1.0\text{ A}$, $P \leq 15\text{ W}$	V_O	-14.4	—	-15.6	Vdc
Input Bias Current	I_{IB}	—	4.4	8.0	mA
Input Bias Current Change -17.5 Vdc $\geq V_I \geq -30\text{ Vdc}$ 5.0 mA $\leq I_O \leq 1.0\text{ A}$ 5.0 mA $\leq I_O \leq 1.5\text{ A}$, $T_J = 25^\circ\text{C}$	ΔI_{IB}	—	—	0.8 0.5	mA
Output Noise Voltage ($T_A = +25^\circ\text{C}$, 10 Hz $\leq f \leq 100\text{ kHz}$)	e_{on}	—	90	—	μV
Ripple Rejection ($I_O = 20\text{ mA}$, $f = 120\text{ Hz}$)	RR	—	60	—	dB
Dropout Voltage $I_O = 1.0\text{ A}$, $T_J = +25^\circ\text{C}$	$V_I - V_O$	—	2.0	—	Vdc
Average Temperature Coefficient of Output Voltage $I_O = 5.0\text{ mA}$, $0^\circ\text{C} \leq T_J \leq +125^\circ\text{C}$	$\Delta V_O / \Delta T$	—	-1.0	—	mV/ $^\circ\text{C}$

Note:

- Load and line regulation are specified at constant junction temperature. Changes in V_O due to heating effects must be taken into account separately. Pulse testing with low duty cycle is used.

MC7900 Series

T-58-11-13

MC7912C ELECTRICAL CHARACTERISTICS ($V_I = -19$ V, $I_O = 500$ mA, $0^\circ\text{C} < T_J < +125^\circ\text{C}$ unless otherwise noted.)

Characteristic	Symbol	Min	Typ	Max	Unit
Output Voltage ($T_J = +25^\circ\text{C}$)	V_O	-11.5	-12	-12.5	Vdc
Line Regulation (Note 1) ($T_J = +25^\circ\text{C}$, $I_O = 100$ mA) -14.5 Vdc $\geq V_I \geq -30$ Vdc -16 Vdc $\geq V_I \geq -22$ Vdc ($T_J = +25^\circ\text{C}$, $I_O = 500$ mA) -14.5 Vdc $\geq V_I \geq -30$ Vdc -16 Vdc $\geq V_I \geq -22$ Vdc	Reg _{line}	—	13 6.0	120 60	mV
Load Regulation ($T_J = +25^\circ\text{C}$) (Note 1) 5.0 mA $\leq I_O \leq 1.5$ A 250 mA $\leq I_O \leq 750$ mA	Reg _{load}	—	46 17	240 120	mV
Output Voltage -14.5 Vdc $\geq V_I \geq -27$ Vdc, 5.0 mA $\leq I_O \leq 1.0$ A, $P \leq 15$ W	V_O	-11.4	—	-12.6	Vdc
Input Bias Current ($T_J = +25^\circ\text{C}$)	I_{IB}	—	4.4	8.0	mA
Input Bias Current Change -14.5 Vdc $\geq V_I \geq -30$ Vdc 5.0 mA $\leq I_O \leq 1.5$ A	ΔI_{IB}	—	—	1.0 0.5	mA
Output Noise Voltage ($T_A = +25^\circ\text{C}$, 10 Hz $\leq f \leq 100$ kHz)	e_{on}	—	75	—	μV
Ripple Rejection ($I_O = 20$ mA, $f = 120$ Hz)	RR	—	61	—	dB
Dropout Voltage $I_O = 1.0$ A, $T_J = +25^\circ\text{C}$	$V_I - V_O$	—	2.0	—	Vdc
Average Temperature Coefficient of Output Voltage $I_O = 5.0$ mA, $0^\circ\text{C} \leq T_J \leq +125^\circ\text{C}$	$\Delta V_O / \Delta T$	—	-1.0	—	mV/ $^\circ\text{C}$

MC7912AC ELECTRICAL CHARACTERISTICS ($V_I = -19$ V, $I_O = 500$ mA, $0^\circ\text{C} < T_J < +125^\circ\text{C}$ unless otherwise noted.)

Characteristic	Symbol	Min	Typ	Max	Unit
Output Voltage ($T_J = +25^\circ\text{C}$)	V_O	-11.75	-12	-12.25	Vdc
Line Regulation (Note 1) -16 Vdc $\geq V_I \geq -22$ Vdc; $I_O = 1.0$ A, $T_J = 25^\circ\text{C}$ -16 Vdc $\geq V_I \geq -22$ Vdc; $I_O = 1.0$ A -14.8 Vdc $\geq V_I \geq -30$ Vdc; $I_O = 500$ mA -14.5 Vdc $\geq V_I \geq -27$ Vdc; $I_O = 1.0$ A, $T_J = 25^\circ\text{C}$	Reg _{line}	—	6.0 24 24 13	60 120 120 120	mV
Load Regulation (Note 1) 5.0 mA $\leq I_O \leq 1.5$ A, $T_J = 25^\circ\text{C}$ 250 mA $\leq I_O \leq 750$ mA 5.0 mA $\leq I_O \leq 1.0$ A	Reg _{load}	—	46 17 35	150 75 150	mV
Output Voltage -14.8 Vdc $\geq V_I \geq -27$ Vdc, 5.0 mA $\leq I_O \leq 1.0$ A, $P \leq 15$ W	V_O	-11.5	—	-12.5	Vdc
Input Bias Current	I_{IB}	—	4.4	8.0	mA
Input Bias Current Change -15 Vdc $\geq V_I \geq -30$ Vdc 5.0 mA $\leq I_O \leq 1.0$ A 5.0 mA $\leq I_O \leq 1.5$ A, $T_J = 25^\circ\text{C}$	ΔI_{IB}	—	—	0.8 0.5 0.5	mA
Output Noise Voltage ($T_A = +25^\circ\text{C}$, 10 Hz $\leq f \leq 100$ kHz)	e_{on}	—	75	—	μV
Ripple Rejection ($I_O = 20$ mA, $f = 120$ Hz)	RR	—	61	—	dB
Dropout Voltage $I_O = 1.0$ A, $T_J = +25^\circ\text{C}$	$V_I - V_O$	—	2.0	—	Vdc
Average Temperature Coefficient of Output Voltage $I_O = 5.0$ mA, $0^\circ\text{C} \leq T_J \leq +125^\circ\text{C}$	$\Delta V_O / \Delta T$	—	-1.0	—	mV/ $^\circ\text{C}$

Note:

1. Load and line regulation are specified at constant junction temperature. Changes in V_O due to heating effects must be taken into account separately. Pulse testing with low duty cycle is used.

MC7900 Series

T-58-11-13

MC7918C ELECTRICAL CHARACTERISTICS ($V_I = -27$ V, $I_O = 500$ mA, $0^\circ\text{C} < T_J < +125^\circ\text{C}$ unless otherwise noted.)

Characteristic	Symbol	Min	Typ	Max	Unit
Output Voltage ($T_J = +25^\circ\text{C}$)	V_O	-17.3	-18	-18.7	Vdc
Line Regulation (Note 1) ($T_J = +25^\circ\text{C}$, $I_O = 100$ mA) -21 Vdc $\geq V_I \geq -33$ Vdc -24 Vdc $\geq V_I \geq -30$ Vdc ($T_J = +25^\circ\text{C}$, $I_O = 500$ mA) -21 Vdc $\geq V_I \geq -33$ Vdc -24 Vdc $\geq V_I \geq -30$ Vdc	Reg _{line}	—	25 10	180 90	mV
Load Regulation ($T_J = +25^\circ\text{C}$) (Note 1) 5.0 mA $\leq I_O \leq 1.5$ A 250 mA $\leq I_O \leq 750$ mA	Reg _{load}	—	110 55	360 180	mV
Output Voltage -21 Vdc $\geq V_I \geq -33$ Vdc, 5.0 mA $\leq I_O \leq 1.0$ A, $P \leq 15$ W	V_O	-17.1	—	-18.9	Vdc
Input Bias Current ($T_J = +25^\circ\text{C}$)	I_{IB}	—	4.5	8.0	mA
Input Bias Current Change -21 Vdc $\geq V_I \geq -33$ Vdc 5.0 mA $\leq I_O \leq 1.5$ A	ΔI_{IB}	—	—	1.0 0.5	mA
Output Noise Voltage ($T_A = +25^\circ\text{C}$, 10 Hz $\leq f \leq 100$ kHz)	e_{on}	—	110	—	μV
Ripple Rejection ($I_O = 20$ mA, $f = 120$ Hz)	RR	—	59	—	dB
Dropout Voltage $I_O = 1.0$ A, $T_J = +25^\circ\text{C}$	$V_I - V_O$	—	2.0	—	Vdc
Average Temperature Coefficient of Output Voltage $I_O = 5.0$ mA, $0^\circ\text{C} \leq T_J \leq +125^\circ\text{C}$	$\Delta V_O / \Delta T$	—	-1.0	—	mV/ $^\circ\text{C}$

MC7924C ELECTRICAL CHARACTERISTICS ($V_I = -33$ V, $I_O = 500$ mA, $0^\circ\text{C} < T_J < +125^\circ\text{C}$ unless otherwise noted.)

Characteristic	Symbol	Min	Typ	Max	Unit
Output Voltage ($T_J = +25^\circ\text{C}$)	V_O	-23	-24	-25	Vdc
Line Regulation (Note 1) ($T_J = +25^\circ\text{C}$, $I_O = 100$ mA) -27 Vdc $\geq V_I \geq -38$ Vdc -30 Vdc $\geq V_I \geq -36$ Vdc ($T_J = +25^\circ\text{C}$, $I_O = 500$ mA) -27 Vdc $\geq V_I \geq -38$ Vdc -30 Vdc $\geq V_I \geq -36$ Vdc	Reg _{line}	—	31 14	240 120	mV
Load Regulation ($T_J = +25^\circ\text{C}$) (Note 1) 5.0 mA $\leq I_O \leq 1.5$ A 250 mA $\leq I_O \leq 750$ mA	Reg _{load}	—	150 85	480 240	mV
Output Voltage -27 Vdc $\geq V_I \geq -38$ Vdc, 5.0 mA $\leq I_O \leq 1.0$ A, $P \leq 15$ W	V_O	-22.8	—	-25.2	Vdc
Input Bias Current ($T_J = +25^\circ\text{C}$)	I_{IB}	—	4.6	8.0	mA
Input Bias Current Change -27 Vdc $\geq V_I \geq -38$ Vdc 5.0 mA $\leq I_O \leq 1.5$ A	ΔI_{IB}	—	—	1.0 0.5	mA
Output Noise Voltage ($T_A = +25^\circ\text{C}$, 10 Hz $\leq f \leq 100$ kHz)	e_{on}	—	170	—	μV
Ripple Rejection ($I_O = 20$ mA, $f = 120$ Hz)	RR	—	56	—	dB
Dropout Voltage $I_O = 1.0$ A, $T_J = +25^\circ\text{C}$	$V_I - V_O$	—	2.0	—	Vdc
Average Temperature Coefficient of Output Voltage $I_O = 5.0$ mA, $0^\circ\text{C} \leq T_J \leq +125^\circ\text{C}$	$\Delta V_O / \Delta T$	—	-1.0	—	mV/ $^\circ\text{C}$

Note:

1. Load and line regulation are specified at constant junction temperature. Changes in V_O due to heating effects must be taken into account separately. Pulse testing with low duty cycle is used.

MC7900 Series

T-58-11-13

TYPICAL CHARACTERISTICS
($T_A = +25^\circ\text{C}$ unless otherwise noted.)

FIGURE 1 - WORST CASE POWER DISSIPATION AS A FUNCTION OF AMBIENT TEMPERATURE

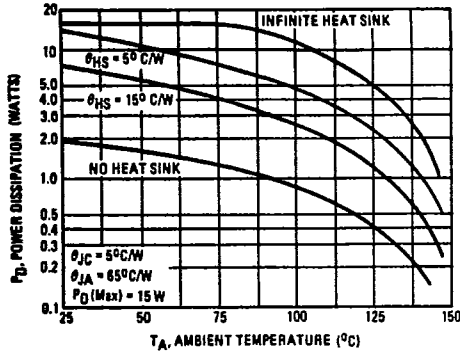

FIGURE 2 - WORST CASE POWER DISSIPATION AS A FUNCTION OF AMBIENT TEMPERATURE

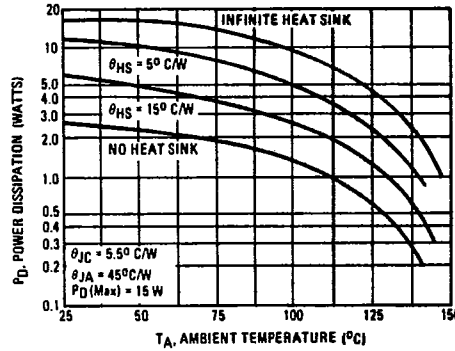

FIGURE 3 - PEAK OUTPUT CURRENT AS A FUNCTION OF INPUT-OUTPUT DIFFERENTIAL VOLTAGE

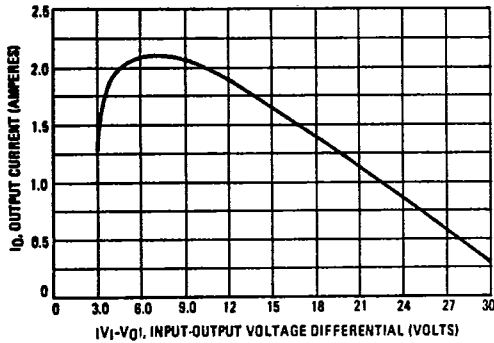

FIGURE 4 - RIPPLE REJECTION AS A FUNCTION OF FREQUENCY

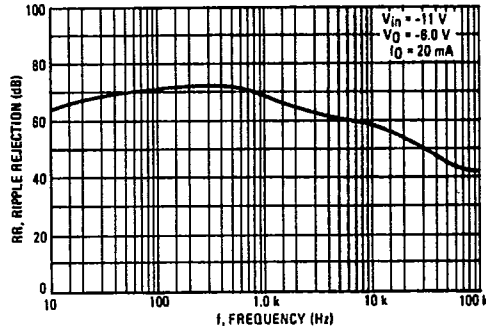

FIGURE 5 - RIPPLE REJECTION AS A FUNCTION OF OUTPUT VOLTAGES

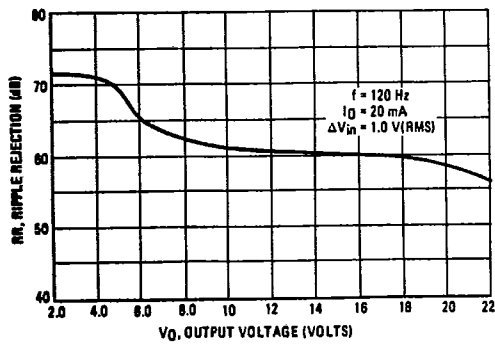
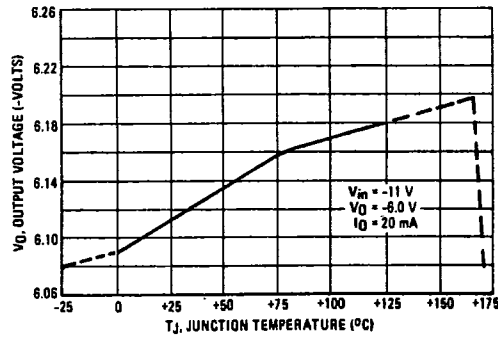

FIGURE 6 - OUTPUT VOLTAGE AS A FUNCTION OF JUNCTION TEMPERATURE



MC7900 Series

T-58-11-13

TYPICAL CHARACTERISTICS (continued)

FIGURE 7 - QUIESCENT CURRENT AS A FUNCTION OF TEMPERATURE

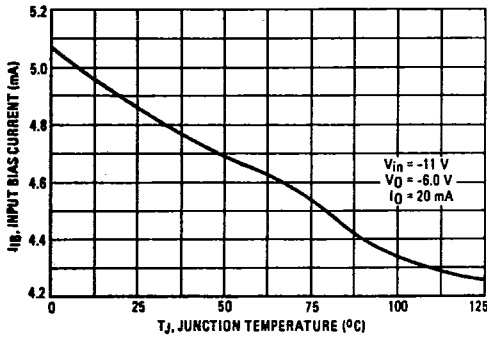

DEFINITIONS

Line Regulation - The change in output voltage for a change in the input voltage. The measurement is made under conditions of low dissipation or by using pulse techniques such that the average chip temperature is not significantly affected.

Load Regulation - The change in output voltage for a change in load current at constant chip temperature.

Maximum Power Dissipation - The maximum total device dissipation for which the regulator will operate within specifications.

Input Bias Current - That part of the input current that is not delivered to the load.

Output Noise Voltage - The rms ac voltage at the output, with constant load and no input ripple, measured over a specified frequency range.

Long Term Stability - Output voltage stability under accelerated life test conditions with the maximum rated voltage listed in the devices' electrical characteristics and maximum power dissipation.

APPLICATIONS INFORMATION

Design Considerations

The MC7900 Series of fixed voltage regulators are designed with Thermal Overload Protection that shuts down the circuit when subjected to an excessive power overload condition, Internal Short-Circuit Protection that limits the maximum current the circuit will pass, and Output Transistor Safe-Area Compensation that reduces the output short-circuit current as the voltage across the pass transistor is increased.

In many low current applications, compensation capacitors are not required. However, it is recommended that the regulator input be bypassed with a capacitor if the regulator is connected to the power supply filter with long wire lengths, or if the output load capacitance is large. An input bypass capacitor should be selected to provide good high-frequency characteristics to insure stable operation under all load conditions. A 0.33 μF or larger tantalum, mylar, or other capacitor having low internal impedance at high frequencies should be chosen. The bypass capacitor should be mounted with the shortest possible leads directly across the regulators input terminals. Normally good construction techniques should be used to minimize ground loops and lead resistance drops since the regulator has no external sense lead. Bypassing the output is also recommended.

FIGURE 8 - CURRENT REGULATOR

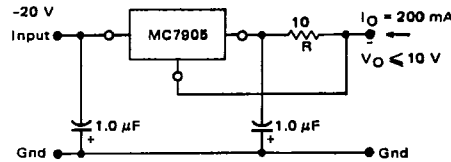

The MC7905, -5.0 V regulator can be used as a constant current source when connected as above. The output current is the sum of resistor R current and quiescent bias current as follows:

$$I_O = \frac{5.0 \text{ V}}{R} + I_B$$

The quiescent current for this regulator is typically 4.3 mA. The 5.0 volt regulator was chosen to minimize dissipation and to allow the output voltage to operate to within 6.0 V below the input voltage.

FIGURE 9 - CURRENT BOOST REGULATOR (-5.0 V @ 4.0 A, with 5.0 A current limiting)

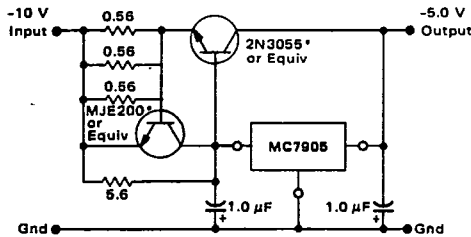

* Mounted on common heat sink, Motorola MS-10 or equivalent.

When a boost transistor is used, short-circuit currents are equal to the sum of the series pass and regulator limits, which are measured at 3.2 A and 1.8 A respectively in this case. Series pass limiting is approximately equal to 0.6 V/R_{SC}. Operation beyond this point to the peak current capability of the MC7905C is possible if the regulator is mounted on a heat sink; otherwise thermal shutdown will occur when the additional load current is picked up by the regulator.

FIGURE 10 - OPERATIONAL AMPLIFIER SUPPLY (±15 V @ 1.0 A)

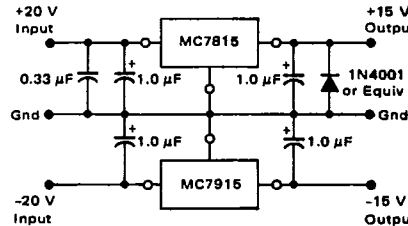

The MC7815 and MC7915 positive and negative regulators may be connected as shown to obtain a dual power supply for operational amplifiers. A clamp diode should be used at the output of the MC7815 to prevent potential latch-up problems whenever the output of the positive regulator (MC7815) is drawn below ground with an output current greater than 200 mA.

SECTION 19 PACKAGE OUTLINE DIMENSIONS

T-90-20

K SUFFIX METAL PACKAGE CASE 1-03 R_{θJA} = 45°C/W (TYP) (TO-3)

DIM	MILLIMETERS		INCHES	
	MIN	MAX	MIN	MAX
B	—	22.23	—	0.875
C	8.35	11.43	0.329	0.450
D	0.97	1.09	0.038	0.042
E	—	3.43	—	0.135
F	30.15 BSC	—	1.187 BSC	—
G	10.92 BSC	—	0.430 BSC	—
H	5.46 BSC	—	0.215 BSC	—
J	16.89 BSC	—	0.665 BSC	—
K	7.92	—	0.312	—
Q	3.94	4.09	0.151	0.161
R	—	13.34	—	0.525
T	—	4.78	—	0.188
V	3.94	4.09	0.151	0.161

- NOTES:
 1. DIAMETER V AND SURFACE W ARE DATUMS.
 2. POSITIONAL TOLERANCE FOR HOLE G:
 (M) ϕ 0.25 (0.010) (M) | W | V | (M)
 3. POSITIONAL TOLERANCE FOR LEADS:
 (F) ϕ 0.30 (0.012) (M) | W | V | (M) | G | (M)

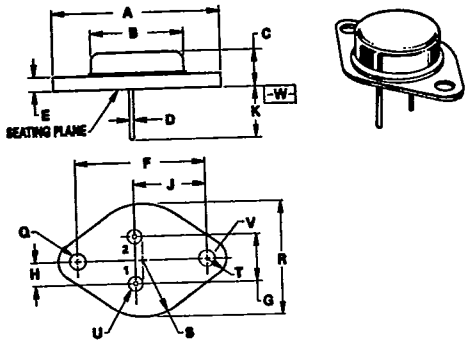

LP, P, Z SUFFIX PLASTIC PACKAGE CASE 29-04 R_{θJA} = 200°C/W (TYP) (TO-226AA/TO-92)

DIM	MILLIMETERS		INCHES	
	MIN	MAX	MIN	MAX
A	4.32	5.33	0.170	0.210
B	4.45	5.20	0.175	0.205
C	3.18	4.19	0.125	0.165
D	0.41	0.55	0.016	0.022
F	0.41	0.48	0.016	0.019
G	1.15	1.39	0.045	0.055
H	—	2.54	—	0.100
J	2.42	2.66	0.095	0.105
K	12.70	—	0.500	—
L	6.35	—	0.250	—
N	2.04	2.66	0.080	0.105
P	2.93	—	0.115	—
R	3.43	—	0.135	—
S	0.39	0.50	0.015	0.020

- NOTES:
 1. CONTOUR OF PACKAGE BEYOND ZONE "P" IS UNCONTROLLED.
 2. DIM "F" APPLIES BETWEEN "H" AND "L". DIM "D" & "S" APPLIES BETWEEN "L" & 12.70mm (0.5") FROM SEATING PLANE. LEAD DIM IS UNCONTROLLED IN "H" & BEYOND 12.70mm (0.5") FROM SEATING PLANE.
 3. CONTROLLING DIM: INCH.

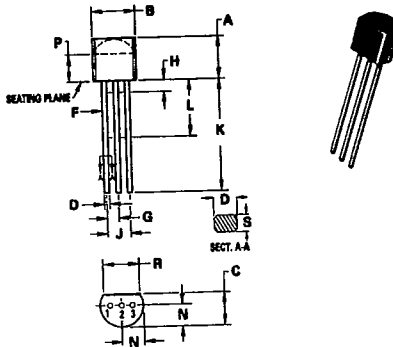

G, H SUFFIX METAL PACKAGE CASE 79-05 R_{θJA} = 185°C/W (TYP) (TO-39)

DIM	MILLIMETERS		INCHES	
	MIN	MAX	MIN	MAX
A	9.02	9.29	0.355	0.366
B	8.01	8.50	0.315	0.335
C	4.20	4.57	0.165	0.180
D	0.44	0.53	0.017	0.021
E	0.44	0.68	0.017	0.036
F	0.41	0.48	0.016	0.019
G	5.08 BSC	—	0.200 BSC	—
H	0.77	0.86	0.029	0.034
J	0.74	1.01	0.029	0.040
K	12.70	19.05	0.500	0.750
L	6.35	—	0.250	—
M	45° BSC	—	45° BSC	—
P	—	1.27	—	0.050
R	2.34	—	0.100	—

- NOTES:
 1. DIMENSIONING AND TOLERANCING PER ANSI Y14.5M, 1982.
 2. CONTROLLING DIMENSION: INCH.
 3. DIMENSION J MEASURED FROM DIMENSION A MAXIMUM.
 4. DIMENSION B SHALL NOT VARY MORE THAN 0.25 (0.010) IN ZONE R. THIS ZONE CONTROLLED FOR AUTOMATIC HANDLING.
 5. DIMENSION F APPLIES BETWEEN DIMENSION P AND L. DIMENSION D APPLIES BETWEEN DIMENSION L AND K MINIMUM. LEAD DIAMETER IS UNCONTROLLED IN DIMENSION P AND BEYOND DIMENSION K MINIMUM.

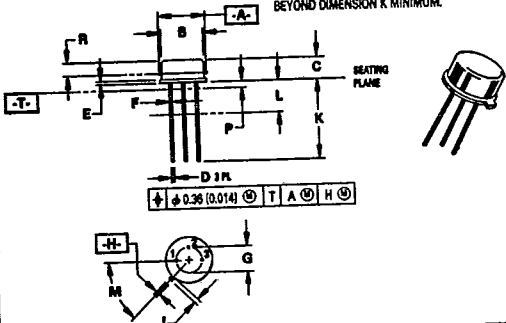

KC, T SUFFIX PLASTIC PACKAGE CASE 221A-04 R_{θJA} = 65°C/W (TYP) (TO-220AB)

DIM	MILLIMETERS		INCHES	
	MIN	MAX	MIN	MAX
A	14.48	15.75	0.570	0.620
B	9.68	10.28	0.380	0.405
C	4.07	4.82	0.160	0.190
D	0.64	0.88	0.025	0.035
F	3.61	3.73	0.142	0.147
G	2.42	2.66	0.095	0.105
H	2.80	3.93	0.110	0.155
J	0.36	0.55	0.014	0.022
K	12.70	14.27	0.500	0.562
L	1.15	1.39	0.045	0.055
N	4.83	5.33	0.190	0.210
Q	2.54	3.04	0.100	0.120
R	2.04	2.79	0.080	0.110
S	1.15	1.39	0.045	0.055
T	5.97	6.47	0.235	0.255
U	0.09	1.27	0.000	0.050
V	1.15	—	0.045	—
Z	—	2.04	—	0.080

- NOTES:
 1. DIMENSIONING AND TOLERANCING PER ANSI Y14.5M, 1982.
 2. CONTROLLING DIMENSION: INCH.
 3. DIM Z DEFINES A ZONE WHERE ALL BODY AND LEAD IRREGULARITIES ARE ALLOWED.

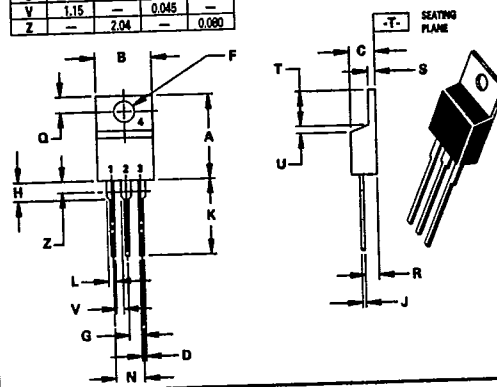

PACKAGE OUTLINE DIMENSIONS (continued)

**T SUFFIX
PLASTIC PACKAGE
CASE 314D-02**

DIM	MILLIMETERS		INCHES	
	MIN	MAX	MIN	MAX
A	14.529	15.570	0.572	0.613
B	9.908	10.541	0.390	0.415
C	4.318	4.572	0.170	0.180
D	0.635	0.965	0.025	0.038
E	1.169	1.397	0.046	0.055
G	1.702 BSC		0.067 BSC	
H	2.109	2.717	0.083	0.107
J	0.381	0.635	0.015	0.025
K	25.907	26.670	1.016	1.050
L	8.052	9.398	0.317	0.370
Q	3.556	3.937	0.140	0.155
U	11.883	12.827	0.468	0.505

NOTES:
1. DIMENSIONING AND TOLERANCING PER ANSI Y14.5M, 1982.
2. CONTROLLING DIMENSION: INCH.

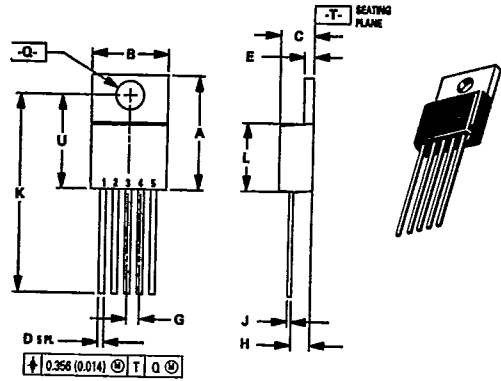

**DT-1 SUFFIX
PLASTIC PACKAGE
CASE 369-03**

DIM	MILLIMETERS		INCHES	
	MIN	MAX	MIN	MAX
A	5.97	6.72	0.235	0.245
B	6.35	6.73	0.250	0.265
C	2.19	2.38	0.086	0.094
D	0.69	0.88	0.027	0.035
E	0.84	0.94	0.033	0.037
F	0.77	1.14	0.030	0.045
G	2.29 BSC		0.090 BSC	
H	0.97	1.06	0.038	0.042
J	0.46	0.58	0.018	0.023
K	8.89	9.65	0.350	0.380
R	5.21	5.46	0.205	0.215
S	1.91	2.28	0.075	0.090
V	0.89	1.27	0.035	0.050

NOTES:
1. DIMENSIONING AND TOLERANCING PER ANSI Y14.5M, 1982.
2. CONTROLLING DIMENSION: INCH.

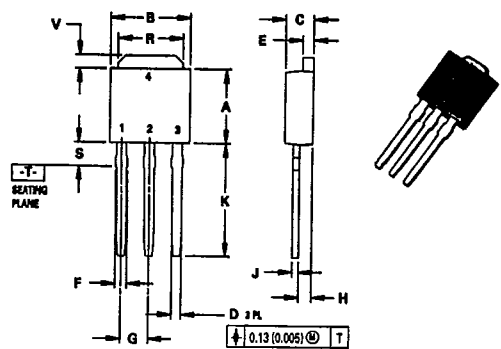

**DT SUFFIX
PLASTIC PACKAGE
CASE 369A-03
DPAK**

DIM	MILLIMETERS		INCHES	
	MIN	MAX	MIN	MAX
A	5.97	6.22	0.235	0.245
B	6.35	6.73	0.250	0.265
C	2.19	2.38	0.086	0.094
D	0.69	0.88	0.027	0.035
E	0.84	0.94	0.033	0.037
F	0.77	1.14	0.030	0.045
G	4.58 BSC		0.180 BSC	
H	0.97	1.06	0.038	0.042
J	0.46	0.58	0.018	0.023
K	2.60	2.89	0.102	0.114
L	2.29 BSC		0.090 BSC	
R	5.21	5.46	0.205	0.215
S	0.64	0.88	0.025	0.035
U	0.51	—	0.020	—
V	0.89	1.27	0.035	0.050
Y	4.32	—	0.170	—

NOTES:
1. DIMENSIONING AND TOLERANCING PER ANSI Y14.5M, 1982.
2. CONTROLLING DIMENSION: INCH.

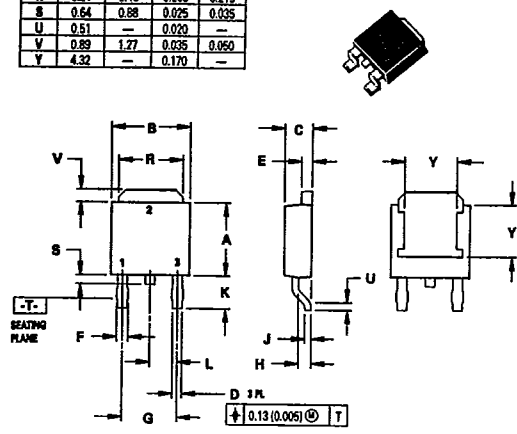

**H, G SUFFIX
METAL PACKAGE
CASE 603-04
 $R_{\theta JA} = 160^{\circ}\text{C/W}$
(TO-100)**

DIM	MILLIMETERS		INCHES	
	MIN	MAX	MIN	MAX
A	8.51	9.29	0.335	0.370
B	7.75	8.51	0.305	0.335
C	4.19	4.70	0.165	0.185
D	0.407	0.533	0.016	0.021
E	—	1.02	—	0.040
F	0.406	0.483	0.016	0.019
G	5.84 BSC		0.230 BSC	
H	0.712	0.864	0.028	0.034
J	0.737	1.14	0.029	0.045
K	12.70	—	0.500	—
L	6.35	12.70	0.250	0.500
M	36° BSC		36° BSC	
P	—	1.27	—	0.050
Q	3.56	4.06	0.140	0.160
R	0.254	1.02	0.010	0.040

NOTE:
LEADS WITHIN 0.18 mm (0.007) RADIUS OF TRUE POSITION AT SEATING PLANE AT MAXIMUM MATERIAL CONDITION.

All JEDEC Dimensions and Notes Apply.

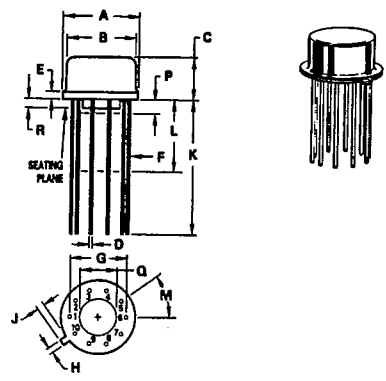

PACKAGE OUTLINE DIMENSIONS (continued)

DIM	MILLIMETERS		INCHES	
	MIN	MAX	MIN	MAX
A	8.51	9.39	0.335	0.370
B	7.75	8.51	0.305	0.335
C	4.19	6.73	0.165	0.265
D	0.407	0.533	0.016	0.021
E	—	1.02	—	0.040
F	0.406	0.483	0.016	0.019
G	5.84 BSC		0.230 BSC	
H	0.712	0.864	0.028	0.034
J	0.737	1.14	0.029	0.045
K	12.70	—	0.500	—
L	6.35	12.70	0.250	0.500
M	36° BSC		36° BSC	
P	—	1.27	—	0.050
Q	3.56	4.06	0.140	0.160
R	0.254	1.02	0.010	0.040

**G SUFFIX
METAL PACKAGE
CASE 603C-01**
R_{θJA} = 150°C/W (TYP)
(TO-100)

- NOTES:
1. LEADS WITHIN 0.18 mm (0.007) RADIUS OF TRUE POSITION TO DIM. "A" & "H" AT SEATING PLANE AT MAXIMUM MATERIAL CONDITION.
2. LEAD DIA UNCONTROLLED BEYOND DIM "K" MIN.

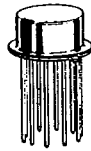
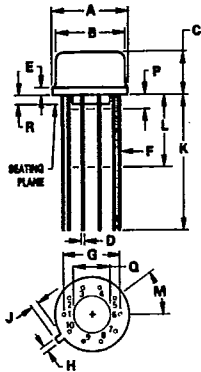

DIM	MILLIMETERS		INCHES	
	MIN	MAX	MIN	MAX
A	19.05	19.94	0.750	0.785
B	6.10	7.49	0.240	0.295
C	—	5.08	—	0.200
D	0.38	0.53	0.015	0.021
F	1.40	1.78	0.055	0.070
G	2.54 BSC		0.100 BSC	
H	0.51	1.14	0.020	0.045
J	0.20	0.30	0.008	0.012
K	3.18	4.32	0.125	0.170
L	7.62 BSC		0.300 BSC	
M	—	15°	—	15°
N	0.51	1.02	0.020	0.040

**DP2, D, J, L, N SUFFIX
CERAMIC PACKAGE
CASE 620-10**
R_{θJA} = 100°C/W (TYP)

- NOTES:
1. LEADS WITHIN 0.13 mm (0.005) RADIUS OF TRUE POSITION AT SEATING PLANE AT MAXIMUM MATERIAL CONDITION.
2. PACKAGE INDEX: NOTCH IN LEAD NOTCH IN CERAMIC OR INK DOT.
3. DIM "L" TO CENTER OF LEADS WHEN FORMED PARALLEL.
4. DIM "A" AND "B" DO NOT INCLUDE GLASS RUN-OUT.
5. DIM "F" MAY NARROW TO 0.76 mm (0.030) WHERE THE LEAD ENTERS THE CERAMIC BODY.

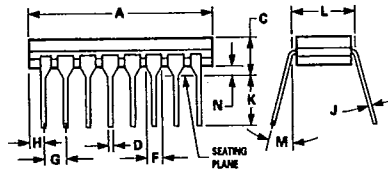
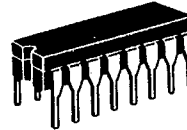
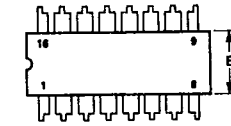

**N, P1 SUFFIX
PLASTIC PACKAGE
CASE 626-05**
R_{θJA} = 100°C/W (TYP)

DIM	MILLIMETERS		INCHES	
	MIN	MAX	MIN	MAX
A	9.40	10.16	0.370	0.400
B	6.10	6.60	0.240	0.260
C	3.94	4.45	0.155	0.175
D	0.38	0.51	0.015	0.020
F	1.02	1.52	0.040	0.060
G	2.54 BSC		0.100 BSC	
H	0.76	1.27	0.030	0.050
J	0.20	0.30	0.008	0.012
K	2.92	3.43	0.115	0.135
L	7.62 BSC		0.300 BSC	
M	—	10°	—	10°
N	0.76	1.01	0.030	0.040

- NOTES:
1. LEAD POSITIONAL TOLERANCE:
⊕ | ⊕ 0.13 (0.005) ⊕ | T | A ⊕ | B ⊕ |
2. DIMENSION L TO CENTER OF LEADS WHEN FORMED PARALLEL.
3. PACKAGE CONTOUR OPTIONAL (ROUND OR SQUARE CORNERS).
4. DIMENSIONS A AND B ARE DATUMS.
5. DIMENSIONING AND TOLERANCING PER ANSI Y14.5M, 1982.

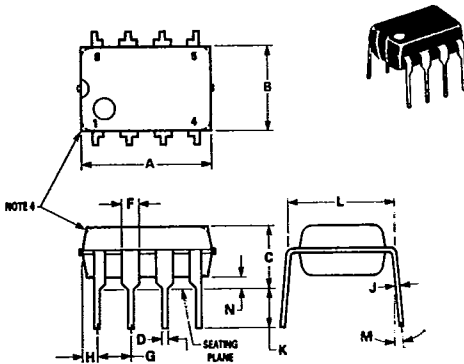

**L SUFFIX
CERAMIC PACKAGE
CASE 632-08**
R_{θJA} = 100°C/W (TYP)
(TO-116)

- NOTES:
1. DIMENSIONING AND TOLERANCING PER ANSI Y14.5M, 1982.
2. CONTROLLING DIMENSION: INCH.
3. DIMENSION L TO CENTER OF LEAD WHEN FORMED PARALLEL.
4. DIM F MAY NARROW TO 0.76 (0.030) WHERE THE LEAD ENTERS THE CERAMIC BODY.

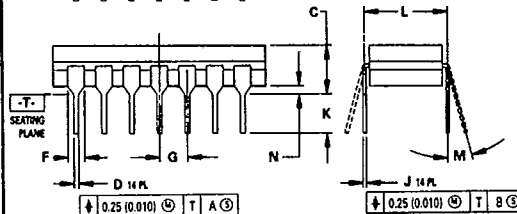
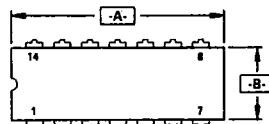

PACKAGE OUTLINE DIMENSIONS (continued)

**N, P, N-14, P2 SUFFIX
PLASTIC PACKAGE
CASE 646-06**
 $R_{\theta JA} = 100^{\circ}\text{C/W (TYP)}$

DIM	MILLIMETERS		INCHES	
	MIN	MAX	MIN	MAX
A	18.16	19.56	0.715	0.770
B	6.10	6.62	0.240	0.260
C	3.69	4.69	0.145	0.185
D	0.39	0.53	0.015	0.021
F	1.02	1.79	0.040	0.070
G	2.54 BSC	0.100 BSC		
H	1.22	2.41	0.052	0.095
J	0.20	0.38	0.008	0.015
K	2.92	3.43	0.115	0.135
L	7.62 BSC	0.300 BSC		
M	0°	10°	0°	10°
N	0.39	1.01	0.015	0.039

- NOTES:
- LEADS WITHIN 0.13 mm (0.005) RADIUS OF TRUE POSITION AT SEATING PLANE AT MAXIMUM MATERIAL CONDITION.
 - DIMENSION "L" TO CENTER OF LEADS WHEN FORMED PARALLEL.
 - DIMENSION "B" DOES NOT INCLUDE MOLD FLASH.
 - ROUNDED CORNERS OPTIONAL.

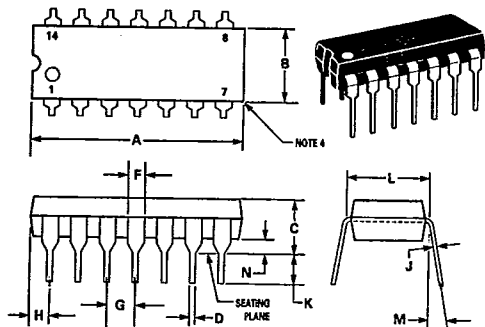

**N, P SUFFIX
PLASTIC PACKAGE
CASE 648-08**
 $R_{\theta JA} = 100^{\circ}\text{C/W (TYP)}$

DIM	MILLIMETERS		INCHES	
	MIN	MAX	MIN	MAX
A	18.80	19.55	0.740	0.770
B	6.35	6.85	0.250	0.270
C	3.69	4.44	0.145	0.175
D	0.39	0.53	0.015	0.021
F	1.02	1.77	0.040	0.070
G	2.54 BSC	0.100 BSC		
H	1.27 BSC	0.050 BSC		
J	0.21	0.38	0.008	0.015
K	2.90	3.30	0.110	0.130
L	7.50	7.74	0.295	0.305
M	0°	10°	0°	10°
S	0.51	1.01	0.020	0.040

- NOTES:
- DIMENSIONING AND TOLERANCING PER ANSI Y14.5M, 1982.
 - CONTROLLING DIMENSION: INCH.
 - DIMENSION "L" TO CENTER OF LEADS WHEN FORMED PARALLEL.
 - DIMENSION "B" DOES NOT INCLUDE MOLD FLASH.
 - ROUNDED CORNERS OPTIONAL.

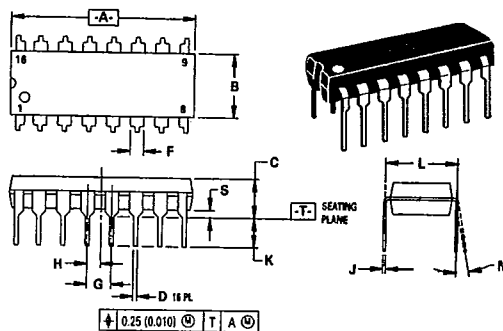

**P SUFFIX
PLASTIC PACKAGE
CASE 648C-02**

DIM	MILLIMETERS		INCHES	
	MIN	MAX	MIN	MAX
A	18.80	21.34	0.740	0.840
B	6.10	6.50	0.240	0.260
C	3.69	4.69	0.145	0.185
D	0.39	0.53	0.015	0.021
F	1.02	1.79	0.040	0.070
G	2.54 BSC	0.100 BSC		
H	0.39	2.41	0.015	0.095
J	0.20	0.38	0.008	0.015
K	2.92	3.43	0.115	0.135
L	7.62 BSC	0.300 BSC		
M	0°	10°	0°	10°
N	0.39	1.01	0.015	0.040

- NOTES:
- LEADS WITHIN 0.13 mm (0.005) RADIUS OF TRUE POSITION AT SEATING PLANE AT MAXIMUM MATERIAL CONDITION.
 - DIMENSION "L" TO CENTER OF LEADS WHEN FORMED PARALLEL.
 - DIMENSION "B" DOES NOT INCLUDE MOLD FLASH.
 - ROUNDED CORNERS OPTIONAL.
 - EXTERNAL LEAD CONNECTION, BETWEEN 4 AND 5, 12 AND 13 AS SHOWN.

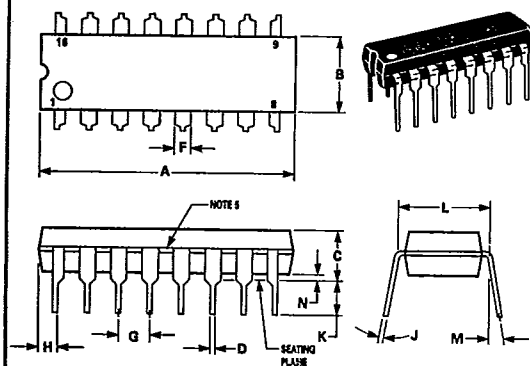

**J-8, J, JG, U, Z SUFFIX
CERAMIC PACKAGE
CASE 693-02**
 $R_{\theta JA} = 100^{\circ}\text{C/W (TYP)}$

DIM	MILLIMETERS		INCHES	
	MIN	MAX	MIN	MAX
A	9.91	10.92	0.390	0.430
B	6.22	6.99	0.245	0.275
C	4.32	5.08	0.170	0.200
D	0.41	0.51	0.016	0.020
F	1.40	1.65	0.055	0.065
G	2.54 BSC	0.100 BSC		
H	1.14	1.65	0.045	0.065
J	0.20	0.30	0.008	0.012
K	3.18	4.06	0.125	0.160
L	7.37	7.87	0.290	0.310
M	—	15°	—	15°
N	0.51	1.02	0.020	0.040

- NOTES:
- LEADS WITHIN 0.13 mm (0.005) RAD OF TRUE POSITION AT SEATING PLANE AT MAXIMUM MATERIAL CONDITION.
 - DIMENSION "L" TO CENTER OF LEADS WHEN FORMED PARALLEL.

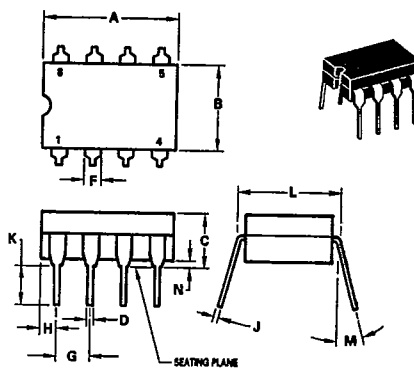

PACKAGE OUTLINE DIMENSIONS (continued)

**A, B, N, P SUFFIX
PLASTIC PACKAGE
CASE 707-02**
 $R_{\theta JA} = 100^{\circ}\text{C/W (TYP)}$

DIM	MILLIMETERS		INCHES	
	MIN	MAX	MIN	MAX
A	22.22	23.24	0.875	0.915
B	6.10	6.60	0.240	0.260
C	3.58	4.57	0.140	0.180
D	0.38	0.56	0.014	0.022
F	1.27	1.78	0.050	0.070
G	2.54 BSC		0.100 BSC	
H	1.02	1.52	0.040	0.060
J	0.20	0.30	0.008	0.012
K	2.92	3.43	0.115	0.135
L	7.62 BSC		0.300 BSC	
M	0°	15°	0°	15°
N	0.51	1.02	0.020	0.040

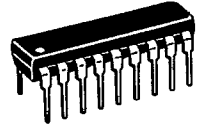

- NOTES:
1. POSITIONAL TOLERANCE OF LEADS (D), SHALL BE WITHIN 0.25mm(0.010) AT MAXIMUM MATERIAL CONDITION, IN RELATION TO SEATING PLANE AND EACH OTHER.
 2. DIMENSION L TO CENTER OF LEADS WHEN FORMED PARALLEL.
 3. DIMENSION B DOES NOT INCLUDE MOLD FLASH.

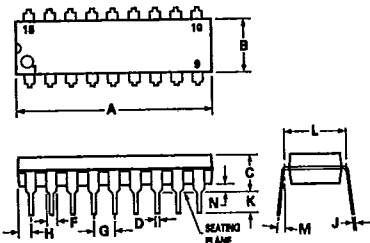

DIM	MILLIMETERS		INCHES	
	MIN	MAX	MIN	MAX
A	22.25	23.11	0.880	0.910
B	6.10	7.49	0.240	0.295
C	—	5.08	—	0.200
D	0.38	0.53	0.015	0.021
F	1.40	1.78	0.055	0.070
G	2.54 BSC		0.100 BSC	
H	0.51	1.14	0.020	0.045
J	0.20	0.30	0.008	0.012
K	3.18	4.32	0.125	0.170
L	7.62 BSC		0.300 BSC	
M	0°	15°	0°	15°
N	0.51	1.02	0.020	0.040

**J, L SUFFIX
CERAMIC PACKAGE
CASE 726-04**
 $R_{\theta JA} = 100^{\circ}\text{C/W (TYP)}$

- NOTES:
1. LEADS, TRUE POSITIONED WITHIN 0.25 mm (0.010) DIA. AT SEATING PLANE, AT MAXIMUM MATERIAL CONDITION.
 2. DIM "L" TO CENTER OF LEADS WHEN FORMED PARALLEL.
 3. DIM "A" & "B" INCLUDES MENISCUS.
 4. "F" DIMENSION IS FOR FULL LEADS. "HALF" LEADS ARE OPTIONAL AT LEAD POSITIONS 1, 9, 10, AND 18.

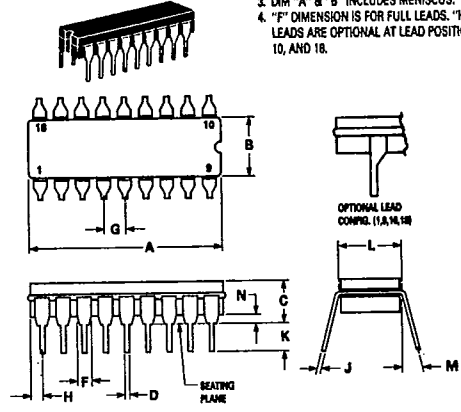

**D SUFFIX
CASE 751-03
PLASTIC PACKAGE
SO-8, SOP-8**
 $R_{\theta JA} = 190^{\circ}\text{C/W (SO-8)}$
 $R_{\theta JA} = 160^{\circ}\text{C/W (SOP-8)}$

DIM	MILLIMETERS		INCHES	
	MIN	MAX	MIN	MAX
A	4.80	5.00	0.189	0.198
B	3.80	4.00	0.150	0.157
C	1.35	1.75	0.054	0.068
D	0.35	0.49	0.014	0.019
F	0.40	1.25	0.016	0.049
G	1.27 BSC		0.050 BSC	
J	0.19	0.25	0.008	0.009
K	0.10	0.25	0.004	0.009
M	0°	7°	0°	7°
P	5.80	6.20	0.229	0.244
R	0.25	0.50	0.010	0.019



- NOTES:
1. DIMENSIONS A AND B ARE DATUMS AND T IS A DATUM SURFACE.
 2. POSITIONAL TOLERANCE FOR D DIMENSION (8 PLACES):
 $\pm 0.25 (0.010) \text{ (T) B (A)}$
 3. POSITIONAL TOLERANCE FOR P DIMENSION (4 PLACES):
 $\pm 0.25 (0.010) \text{ (B)}$
 4. DIMENSIONING AND TOLERANCING PER ANSI Y14.5M, 1982.
 5. CONTROLLING DIMENSION: MILLIMETER.
 6. DIMENSION A AND B DO NOT INCLUDE MOLD PROTRUSION.
 7. MAXIMUM MOLD PROTRUSION 0.15 (0.006) PER SIDE.

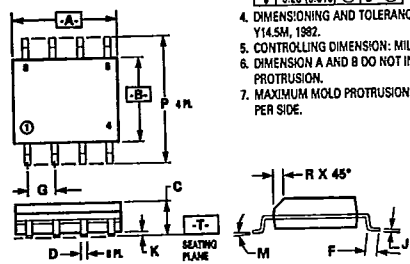

**D SUFFIX
PLASTIC PACKAGE
CASE 751A-02
SO-14**
 $R_{\theta JA} = 145^{\circ}\text{C/W (TYP)}$

DIM	MILLIMETERS		INCHES	
	MIN	MAX	MIN	MAX
A	8.55	8.75	0.337	0.344
B	3.80	4.00	0.150	0.157
C	1.35	1.75	0.054	0.068
D	0.35	0.49	0.014	0.019
F	0.40	1.25	0.016	0.049
G	1.27 BSC		0.050 BSC	
J	0.18	0.25	0.008	0.009
K	0.10	0.25	0.004	0.009
M	0°	7°	0°	7°
P	5.80	6.20	0.229	0.244
R	0.25	0.50	0.010	0.019

- NOTES:
1. DIMENSIONS A AND B ARE DATUMS AND T IS A DATUM SURFACE.
 2. POSITIONAL TOLERANCE FOR D DIMENSION (14 PLACES):
 $\pm 0.25 (0.010) \text{ (T) B (A)}$
 3. POSITIONAL TOLERANCE FOR P DIMENSION (7 PLACES):
 $\pm 0.25 (0.010) \text{ (B)}$
 4. DIMENSIONING AND TOLERANCING PER ANSI Y14.5M, 1982.
 5. CONTROLLING DIMENSION: MILLIMETER.
 6. DIMENSION A AND B DO NOT INCLUDE MOLD PROTRUSION.
 7. MAXIMUM MOLD PROTRUSION 0.15 (0.006) PER SIDE.

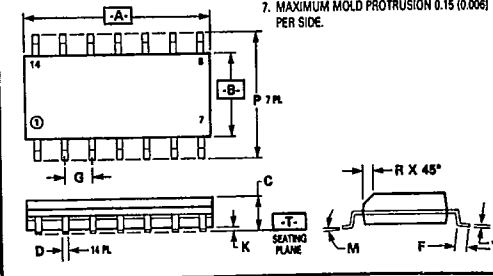
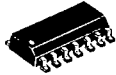

**DW SUFFIX
PLASTIC PACKAGE
CASE 751G-01
SO-16L**

DIM	MILLIMETERS		INCHES	
	MIN	MAX	MIN	MAX
A	10.15	10.45	0.400	0.411
B	7.40	7.60	0.292	0.299
C	2.35	2.65	0.093	0.104
D	0.35	0.49	0.014	0.019
F	0.50	0.90	0.020	0.035
G	1.27 BSC		0.050 BSC	
J	0.25	0.32	0.010	0.012
K	0.10	0.25	0.004	0.009
M	0°	7°	0°	7°
P	10.05	10.65	0.395	0.415
	0.25	0.75	0.010	0.029

- NOTES:
1. DIMENSIONS A AND B ARE DATUMS AND T IS A DATUM SURFACE.
 2. DIMENSIONING AND TOLERANCING PER ANSI Y14.5M, 1982.
 3. CONTROLLING DIMENSION: MILLIMETER.
 4. DIMENSION A AND B DO NOT INCLUDE MOLD PROTRUSION.
 5. MAXIMUM MOLD PROTRUSION 0.15 (0.006) PER SIDE.

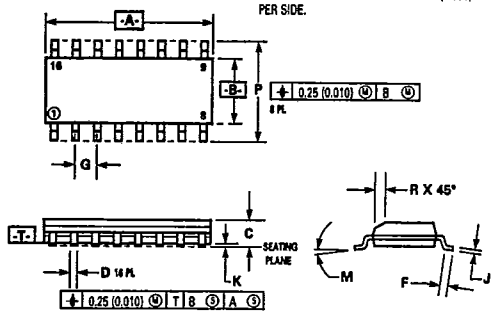
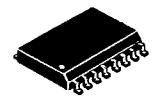

**CASE 762-01
PLASTIC MEDIUM
POWER PACKAGE
SIP-9**

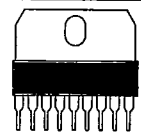

DIM	MILLIMETERS		INCHES	
	MIN	MAX	MIN	MAX
A	22.40	23.00	0.873	0.907
B	6.40	6.80	0.252	0.269
C	3.45	3.65	0.135	0.143
D	0.40	0.55	0.015	0.021
E	3.35	3.60	0.269	0.377
F	1.40	1.60	0.055	0.062
G	2.54 BSC		0.100 BSC	
H	1.81	1.71	0.069	0.067
J	0.380	0.400	0.014	0.015
K	3.30	4.20	0.130	0.165
M	30° BSC		30° BSC	
N	2.50	2.70	0.099	0.106
Q	3.15	3.45	0.124	0.135
R	13.80	13.90	0.539	0.547
S	1.65	1.95	0.064	0.076
U	22.00	22.20	0.866	0.874
V	0.55	0.75	0.021	0.029
W	2.89 BSC		0.113 BSC	
X	0.85	0.75	0.033	0.029
Y	2.70	2.90	0.106	0.110

- NOTES:
1. DIMENSIONS A, AND C ARE DATUMS. AND -T- IS A DATUM PLANE.
 2. POSITIONAL TOLERANCE FOR LEAD DIMENSION D: $\pm 0.25 (0.010) \text{ (T) | A } \text{ (M)}$
 3. POSITIONAL TOLERANCE FOR LEAD DIMENSION J: $\pm 0.25 (0.010) \text{ (T) | C } \text{ (M)}$
 4. POSITIONAL TOLERANCE FOR LEAD DIMENSION Q: $\pm 0.25 (0.010) \text{ (T) | A } \text{ (M)}$
 5. DIMENSIONING AND TOLERANCING PER ANSI Y14.5, 1982.
 6. CONTROLLING DIMENSION: MILLIMETER.

