

SA616

Low-voltage high performance mixer FM IF system

Rev. 3 — 21 June 2010

Product data sheet

1. General description

The SA616 is a low-voltage high performance monolithic FM IF system incorporating a mixer/oscillator, two limiting intermediate frequency amplifiers, quadrature detector, logarithmic Received Signal Strength Indicator (RSSI), voltage regulator and audio and RSSI op amps. The SA616 is available in SSOP20 and HVQFN20 packages.

The SA616 was designed for portable communication applications and will function down to 2.7 V. The RF section is similar to the famous SA615. The audio and RSSI outputs have amplifiers with access to the feedback path. This enables the designer to adjust the output levels or add filtering.

2. Features and benefits

- Low power consumption: 3.5 mA typical at 3 V
- Mixer input to >150 MHz
- Mixer conversion power gain of 17 dB at 45 MHz
- XTAL oscillator effective to 150 MHz (LC oscillator or external oscillator can be used at higher frequencies)
- 102 dB of IF amp/limiter gain
- 2 MHz IF amp/limiter small signal bandwidth
- Temperature compensated logarithmic RSSI with a 80 dB dynamic range
- Low external component count; suitable for crystal/ceramic/LC filters
- Excellent sensitivity: 0.31 μ V into 50 Ω matching network for 12 dB SINAD (Signal-to-Noise-and-Distortion ratio) for 1 kHz tone with RF at 45 MHz and IF at 455 kHz
- SA616 meets cellular radio specifications
- Audio output internal op amp
- RSSI output internal op amp
- Internal op amps with rail-to-rail outputs
- ESD protection: Human Body Model 2 kV; Robot Model 200 V

3. Applications

- Portable cellular radio FM IF
- Cordless phones
- Wireless systems
- RF level meter
- Spectrum analyzer
- Instrumentation



- FSK and ASK data receivers
- Log amps
- Portable high performance communication receiver
- Single conversion VHF receivers

4. Ordering information

Table 1. Ordering information

$T_{amb} = -40\text{ }^{\circ}\text{C to }+85\text{ }^{\circ}\text{C}$

| Type number | Topside mark | Package | | Version |
|-------------|--------------|---------|--|----------|
| | | Name | Description | |
| SA616DK/01 | SA616DK | SSOP20 | plastic shrink small outline package; 20 leads; body width 4.4 mm | SOT266-1 |
| SA616BS | 616B | HVQFN20 | plastic thermal enhanced very thin quad flat package; no leads; 20 terminals; body 4 × 4 × 0.85 mm | SOT917-1 |

5. Block diagram

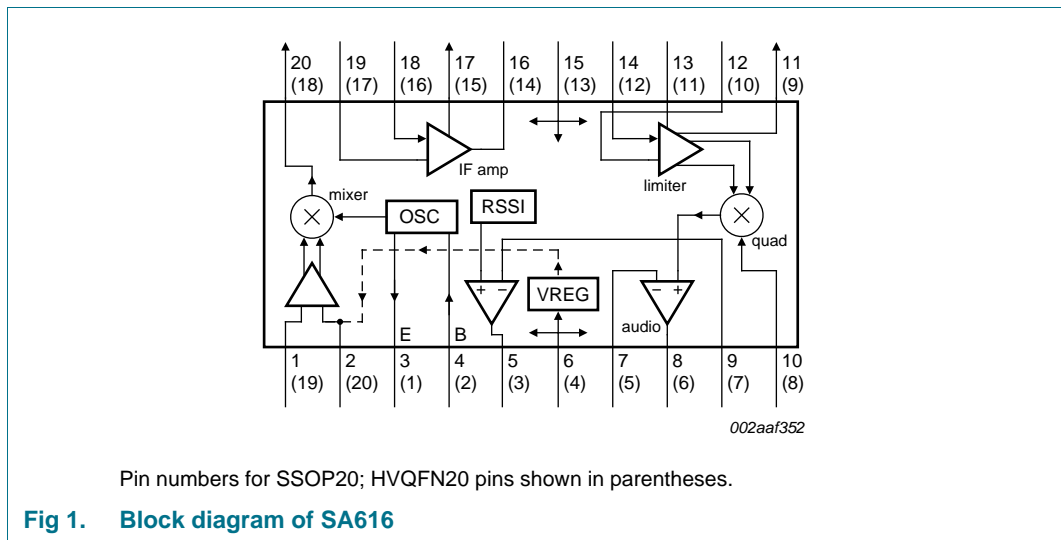

6. Pinning information

6.1 Pinning

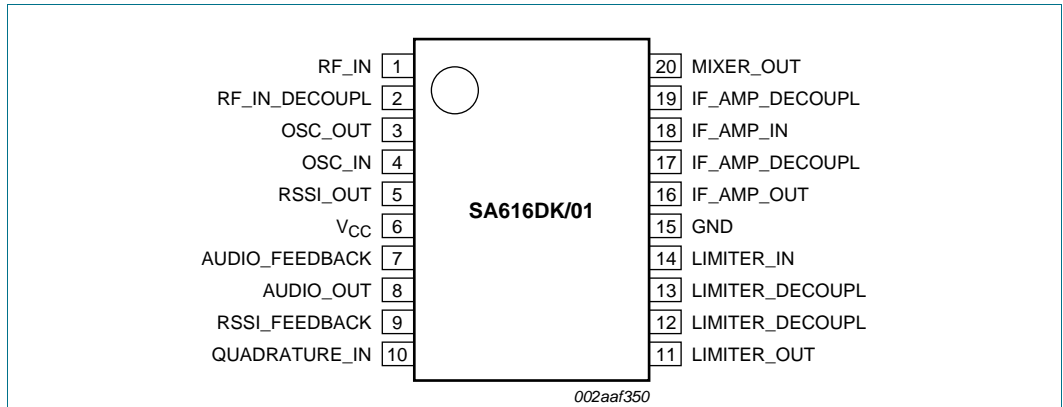

Fig 2. Pin configuration for SSOP20

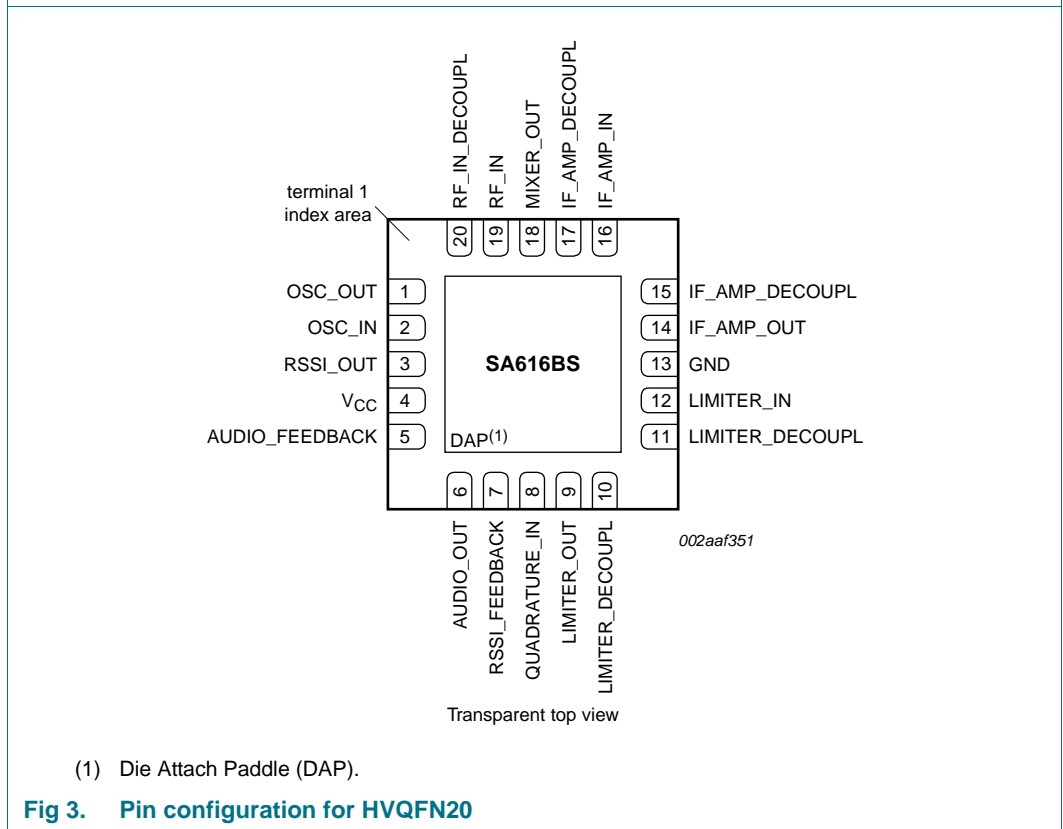

Fig 3. Pin configuration for HVQFN20

6.2 Pin description

Table 2. Pin description

| Symbol | Pin | | Description |
|-----------------|--------|-------------------|--|
| | SSOP20 | HVQFN20 | |
| RF_IN | 1 | 19 | RF input |
| RF_IN_DECOUPL | 2 | 20 | RF input decoupling pin |
| OSC_OUT | 3 | 1 | oscillator output |
| OSC_IN | 4 | 2 | oscillator input |
| RSSI_OUT | 5 | 3 | RSSI output |
| V _{CC} | 6 | 4 | positive supply voltage |
| AUDIO_FEEDBACK | 7 | 5 | audio amplifier negative feedback terminal |
| AUDIO_OUT | 8 | 6 | audio amplifier output |
| RSSI_FEEDBACK | 9 | 7 | RSSI amplifier negative feedback terminal |
| QUADRATURE_IN | 10 | 8 | quadrature detector input terminal |
| LIMITER_OUT | 11 | 9 | limiter amplifier output |
| LIMITER_DECOUPL | 12 | 10 | limiter amplifier decoupling pin |
| LIMITER_DECOUPL | 13 | 11 | limiter amplifier decoupling pin |
| LIMITER_IN | 14 | 12 | limiter amplifier input |
| GND | 15 | 13 ^[1] | ground; negative supply |
| IF_AMP_OUT | 16 | 14 | IF amplifier output |
| IF_AMP_DECOUPL | 17 | 15 | IF amplifier decoupling pin |
| IF_AMP_IN | 18 | 16 | IF amplifier input |
| IF_AMP_DECOUPL | 19 | 17 | IF amplifier decoupling pin |
| MIXER_OUT | 20 | 18 | mixer output |
| - | - | DAP | exposed die attach paddle |

- [1] HVQFN20 package supply ground is connected to both GND pin and exposed center pad. GND pin must be connected to supply ground for proper device operation. For enhanced thermal, electrical, and board level performance, the exposed pad needs to be soldered to the board using a corresponding thermal pad on the board and for proper heat conduction through the board, thermal vias need to be incorporated in the PCB in the thermal pad region.

7. Functional description

The SA616 is an IF signal processing system suitable for second IF systems with input frequency as high as 150 MHz. The bandwidth of the IF amplifier and limiter is at least 2 MHz with 90 dB of gain. The gain/bandwidth distribution is optimized for 455 kHz, 1.5 k Ω source applications. The overall system is well-suited to battery operation as well as high performance and high quality products of all types.

The input stage is a Gilbert cell mixer with oscillator. Typical mixer characteristics include a noise figure of 6.2 dB, conversion gain of 17 dB, and input third-order intercept of -9 dBm. The oscillator will operate in excess of 200 MHz in L/C tank configurations. Hartley or Colpitts circuits can be used up to 100 MHz for crystal configurations. Butler oscillators are recommended for crystal configurations up to 150 MHz.

The output impedance of the mixer is a 1.5 k Ω resistor permitting direct connection to a 455 kHz ceramic filter. The input resistance of the limiting IF amplifiers is also 1.5 k Ω . With most 455 kHz ceramic filters and many crystal filters, no impedance matching network is necessary. The IF amplifier has 43 dB of gain and 5.5 MHz bandwidth. The IF limiter has 60 dB of gain and 4.5 MHz bandwidth.

To achieve optimum linearity of the log signal strength indicator, there must be a 12 dB(v) insertion loss between the first and second IF stages. If the IF filter or interstage network does not cause 12 dB(v) insertion loss, a fixed or variable resistor or an L pad for simultaneous loss and impedance matching can be added between the first IF output (IF_AMP_OUT) and the interstage network. The overall gain will then be 90 dB with 2 MHz bandwidth.

The signal from the second limiting amplifier goes to a Gilbert cell quadrature detector. One port of the Gilbert cell is internally driven by the IF. The other output of the IF is AC-coupled to a tuned quadrature network. This signal, which now has a 90° phase relationship to the internal signal, drives the other port of the multiplier cell.

The demodulated output of the quadrature drives an internal op amp. This op amp can be configured as a unity gain buffer, or for simultaneous gain, filtering, and second-order temperature compensation if needed. It can drive an AC load as low as 5 k Ω with a rail-to-rail output.

A log signal strength completes the circuitry. The output range is greater than 90 dB and is temperature compensated. This log signal strength indicator exceeds the criteria for AMPs or TACs cellular telephone. This signal drives an internal op amp. The op amp is capable of rail-to-rail output. It can be used for gain, filtering, or second-order temperature compensation of the RSSI, if needed.

Remark: $\text{dB}(v) = 20\log V_O/V_I$.

8. Limiting values

Table 3. Limiting values

In accordance with the Absolute Maximum Rating System (IEC 60134).

| Symbol | Parameter | Conditions | Min | Max | Unit |
|-----------|---------------------|------------|-----|------|------|
| V_{CC} | supply voltage | | - | 7 | V |
| T_{stg} | storage temperature | | -65 | +150 | °C |
| T_{amb} | ambient temperature | operating | -40 | +85 | °C |

9. Thermal characteristics

Table 4. Thermal characteristics

| Symbol | Parameter | Conditions | Max | Unit |
|---------------|--|---------------------|-----|------|
| $Z_{th(j-a)}$ | transient thermal impedance from junction to ambient | SA616DK/01 (SSOP20) | 117 | K/W |
| | | SA616BS (HVQFN20) | 40 | K/W |

10. Static characteristics

Table 5. Static characteristics

$V_{CC} = 3\text{ V}$; $T_{amb} = 25\text{ °C}$; unless specified otherwise.

| Symbol | Parameter | Conditions | Min | Typ | Max | Unit |
|----------|----------------|------------|-----|-----|-----|------|
| V_{CC} | supply voltage | | 2.7 | - | 7.0 | V |
| I_{CC} | supply current | | - | 3.5 | 5.0 | mA |

11. Dynamic characteristics

Table 6. Dynamic characteristics

$T_{amb} = 25\text{ }^{\circ}\text{C}$; $V_{CC} = 3\text{ V}$; unless specified otherwise. RF frequency = 45 MHz + 14.5 dBV RF input step-up. IF frequency = 455 kHz; $R_{17} = 2.4\text{ k}\Omega$ and $R_{18} = 3.3\text{ k}\Omega$. RF level = -45 dBm; FM modulation = 1 kHz with $\pm 8\text{ kHz}$ peak deviation. Audio output with de-emphasis filter and C-message weighted filter. Test circuit [Figure 21](#). The parameters listed below are tested using automatic test equipment to assure consistent electrical characteristics. The limits do not represent the ultimate performance limits of the device. Use of an optimized RF layout will improve many of the listed parameters.

| Symbol | Parameter | Conditions | Min | Typ | Max | Unit |
|--|--------------------------------------|--|------|---------|-----|------------|
| Mixer/oscillator section (external LO = 220 mV RMS value) | | | | | | |
| f_i | input frequency | | - | 150 | - | MHz |
| f_{osc} | oscillator frequency | | - | 150 | - | MHz |
| NF | noise figure | at 45 MHz | - | 6.8 | - | dB |
| IP3 _I | input third-order intercept point | 50 Ω source; f1 = 45.0 MHz; f2 = 45.06 MHz; input RF level = -52 dBm | - | -9 | - | dB |
| $G_{p(conv)}$ | conversion power gain | matched 14.5 dBV step-up | 11 | 17 | - | dB |
| | | 50 Ω source | - | 2.5 | - | dB |
| $R_{i(RF)}$ | RF input resistance | single-ended input | - | 8 | - | k Ω |
| $C_{i(RF)}$ | RF input capacitance | | - | 3.0 | 4.0 | pF |
| $R_{o(mix)}$ | mixer output resistance | MIXER_OUT pin | 1.25 | 1.5 | - | k Ω |
| IF section | | | | | | |
| $G_{amp(IF)}$ | IF amplifier gain | 50 Ω source | - | 44 | - | dB |
| G_{lim} | limiter gain | 50 Ω source | - | 58 | - | dB |
| $P_{i(IF)}$ | IF input power | for -3 dB input limiting sensitivity; $R_{17} = 2.4\text{ k}\Omega$; $R_{18} = 3.3\text{ k}\Omega$ (Figure 21); test at IF_AMP_IN pin | - | -105 | - | dBm |
| α_{AM} | AM rejection | 80 % AM 1 kHz | - | 40 | - | dB |
| $V_{o(aud)}$ | audio output voltage | gain of two (2 k Ω AC load) | 60 | 120 | - | mV |
| SINAD | signal-to-noise-and-distortion ratio | IF level -110 dBm | - | 17 | - | dB |
| THD | total harmonic distortion | | -30 | -45 | - | dB |
| S/N | signal-to-noise ratio | no modulation for noise | - | 62 | - | dB |
| $V_{o(RSSI)}$ | RSSI output voltage | RF; $R_9 = 2\text{ k}\Omega$ | | | | |
| | | RF level = -118 dBm | - | 0.3 | 0.8 | V |
| | | RF level = -68 dBm | 0.7 | 1.1 | 2 | V |
| | | RF level = -23 dBm | 1.0 | 1.8 | 2.5 | V |
| $\alpha_{RSSI(range)}$ | RSSI range | | - | 80 | - | dB |
| $\Delta\alpha_{RSSI}$ | RSSI variation | | - | ± 2 | - | dB |
| $Z_{i(IF)}$ | IF input impedance | IF_AMP_IN pin | 1.3 | 1.5 | - | k Ω |
| $Z_{o(IF)}$ | IF output impedance | IF_AMP_OUT pin | - | 0.3 | - | k Ω |
| $Z_{i(lim)}$ | limiter input impedance | LIMITER_IN pin | 1.3 | 1.5 | - | k Ω |
| $Z_{o(lim)}$ | limiter output impedance | LIMITER_OUT pin | - | 0.3 | - | k Ω |
| $V_{o(RMS)}$ | RMS output voltage | LIMITER_OUT pin | - | 130 | - | mV |

Table 6. Dynamic characteristics ...continued

$T_{amb} = 25\text{ }^{\circ}\text{C}$; $V_{CC} = 3\text{ V}$; unless specified otherwise. RF frequency = 45 MHz + 14.5 dBV RF input step-up. IF frequency = 455 kHz; R17 = 2.4 k Ω and R18 = 3.3 k Ω . RF level = -45 dBm; FM modulation = 1 kHz with ± 8 kHz peak deviation. Audio output with de-emphasis filter and C-message weighted filter. Test circuit [Figure 21](#). The parameters listed below are tested using automatic test equipment to assure consistent electrical characteristics. The limits do not represent the ultimate performance limits of the device. Use of an optimized RF layout will improve many of the listed parameters.

| Symbol | Parameter | Conditions | Min | Typ | Max | Unit |
|------------------------------------|--------------------------------------|---|-----|-----|-----|------|
| RF/IF section (internal LO) | | | | | | |
| $V_{o(aud)RMS}$ | RMS audio output voltage | $V_{CC} = 3\text{ V}$; RF level = -27 dBm | - | 120 | - | mV |
| $V_{o(RSSI)}$ | RSSI output voltage | system; $V_{CC} = 3\text{ V}$; RF level = -27 dBm | - | 2.2 | - | V |
| SINAD | signal-to-noise-and-distortion ratio | system; RF level = -117 dBm | - | 12 | - | dB |

12. Performance curves

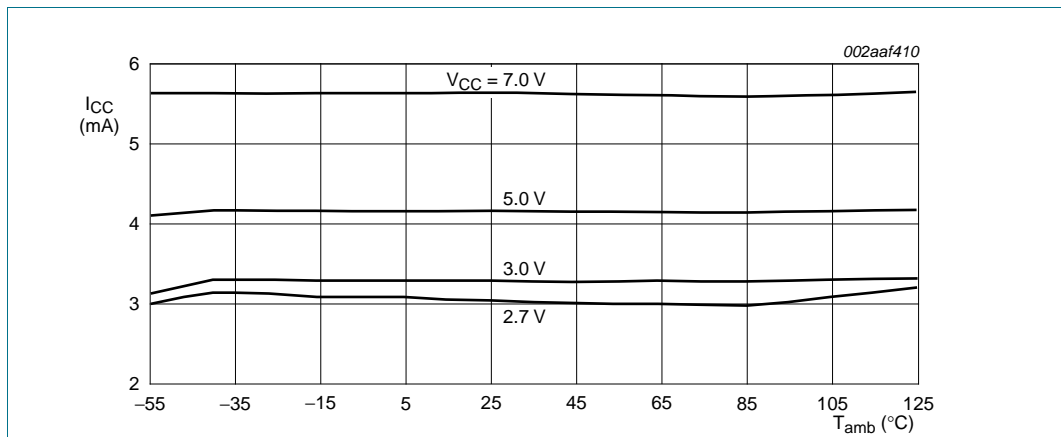

Fig 4. Supply current versus ambient temperature

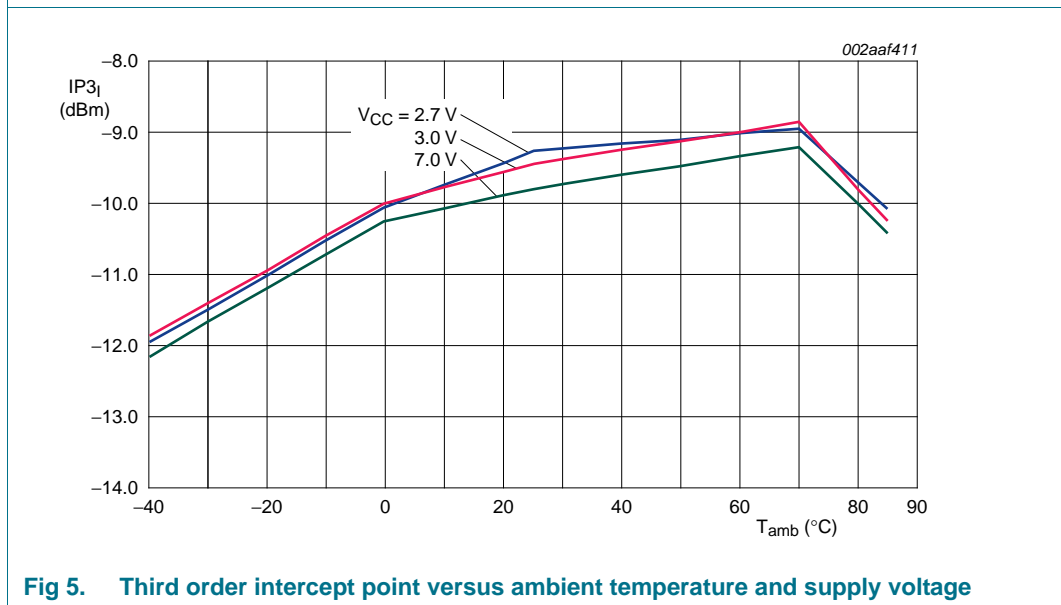

Fig 5. Third order intercept point versus ambient temperature and supply voltage

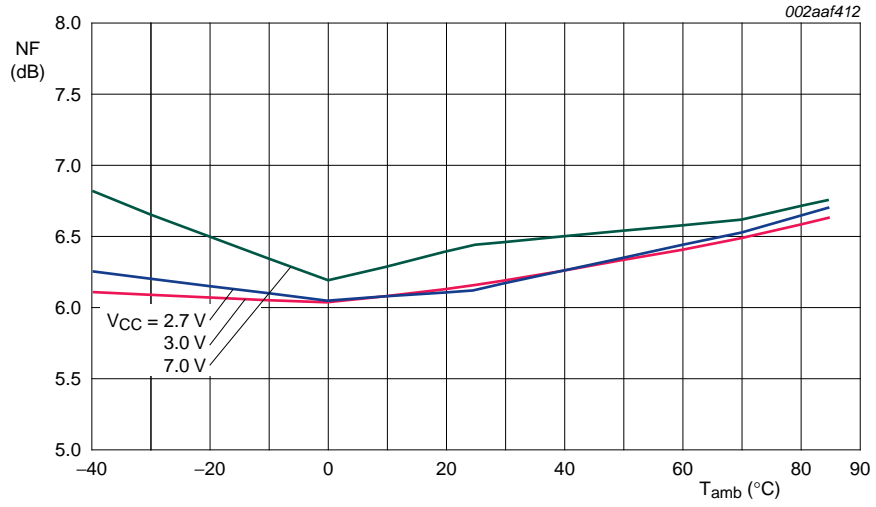

Fig 6. Mixer noise figure versus ambient temperature and supply voltage

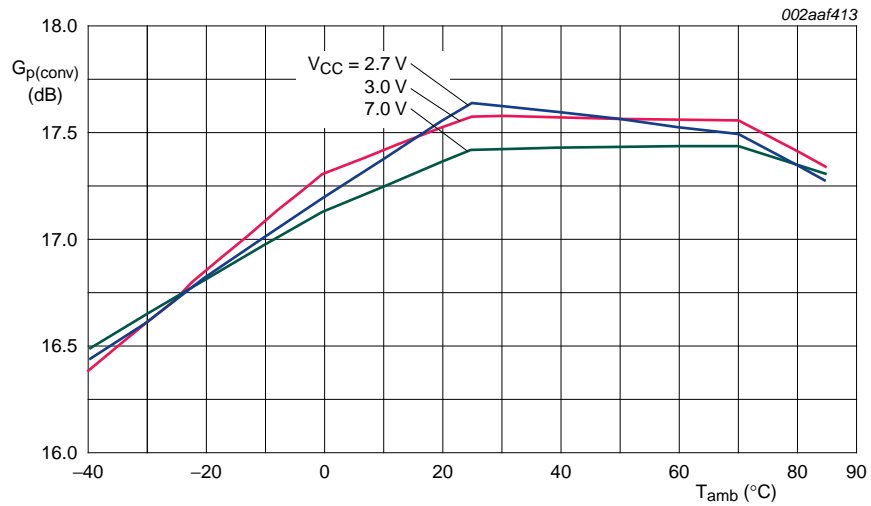
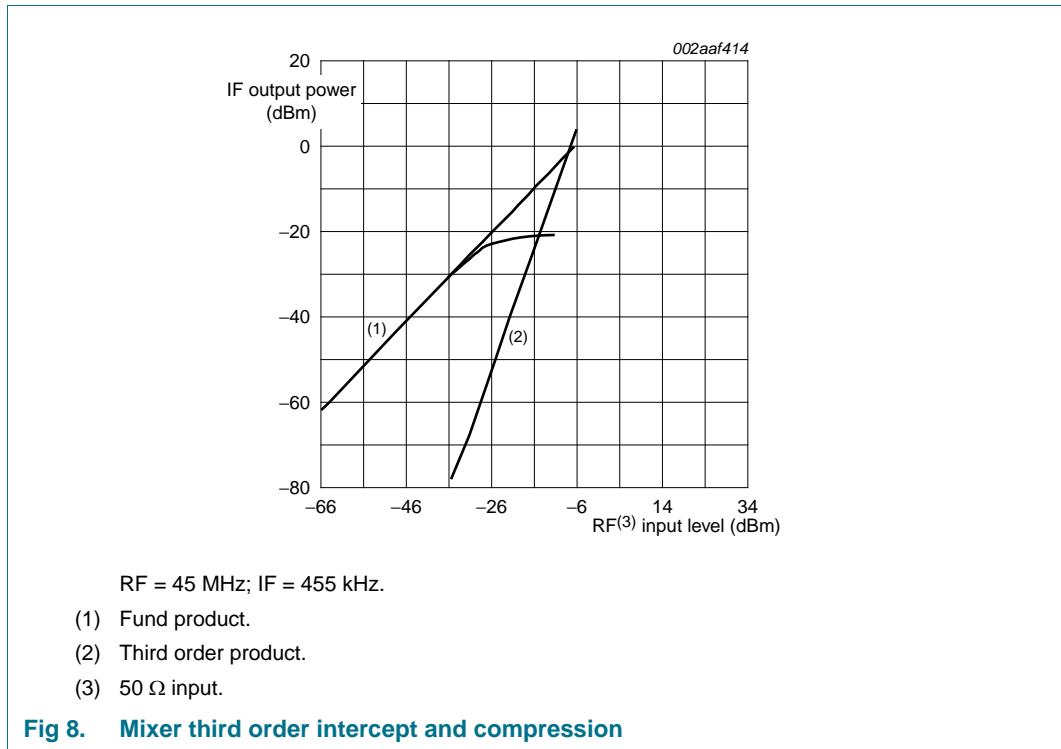
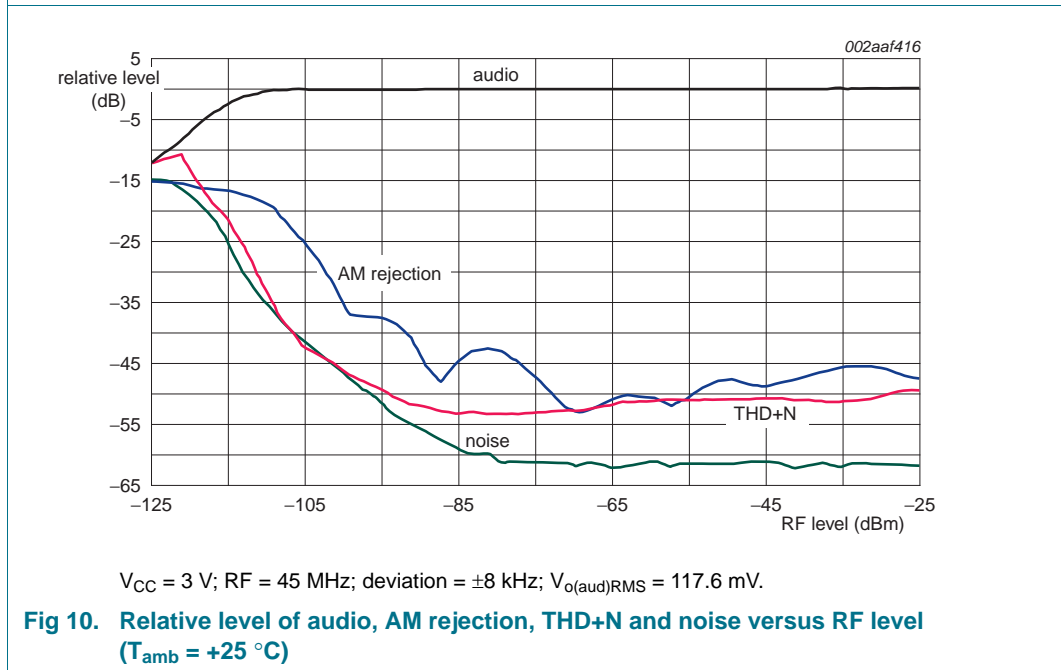
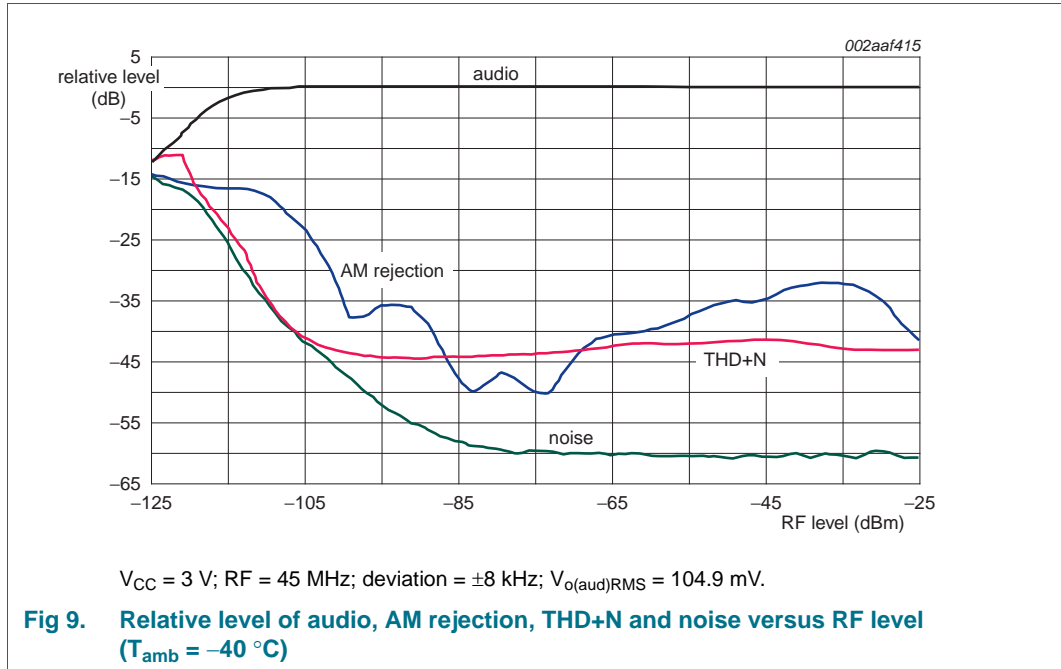
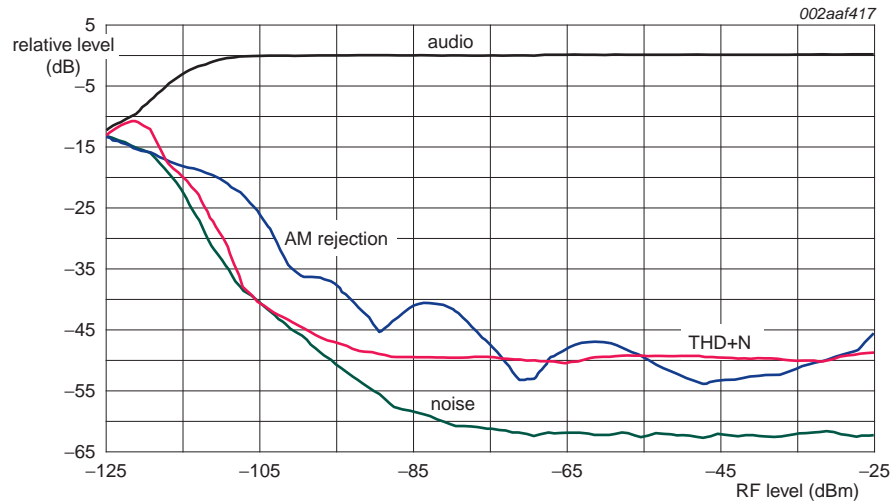

Fig 7. Conversion gain versus ambient temperature and supply voltage







$V_{CC} = 3\text{ V}$; $RF = 45\text{ MHz}$; deviation = $\pm 8\text{ kHz}$; $V_{o(aud)RMS} = 127\text{ mV}$.

Fig 11. Relative level of audio, AM rejection, THD+N and noise versus RF level ($T_{amb} = +85\text{ }^{\circ}\text{C}$)

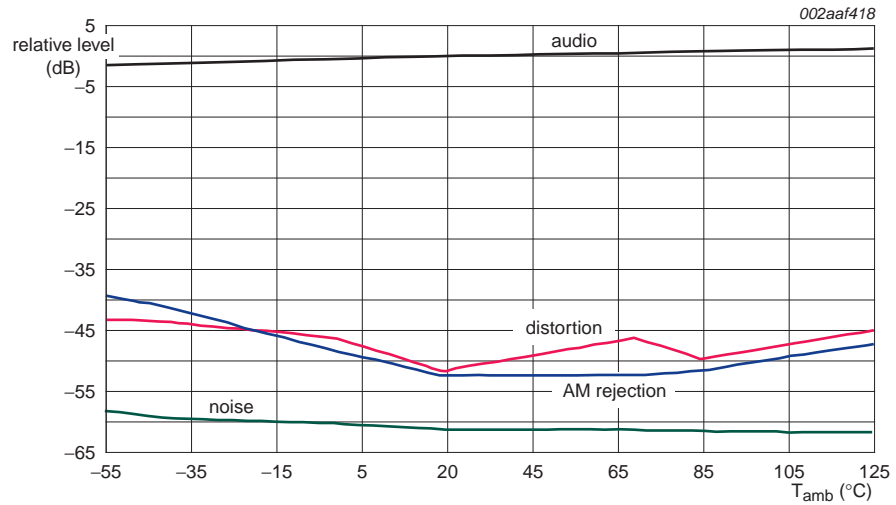

$V_{CC} = 3\text{ V}$; $RF = 45\text{ MHz}$; $RF\text{ level} = -45\text{ dBm}$; deviation = $\pm 8\text{ kHz}$; $V_{o(aud)RMS} = +117.6\text{ mV}$.

Fig 12. Relative audio level, distortion, AM rejection and noise versus ambient temperature

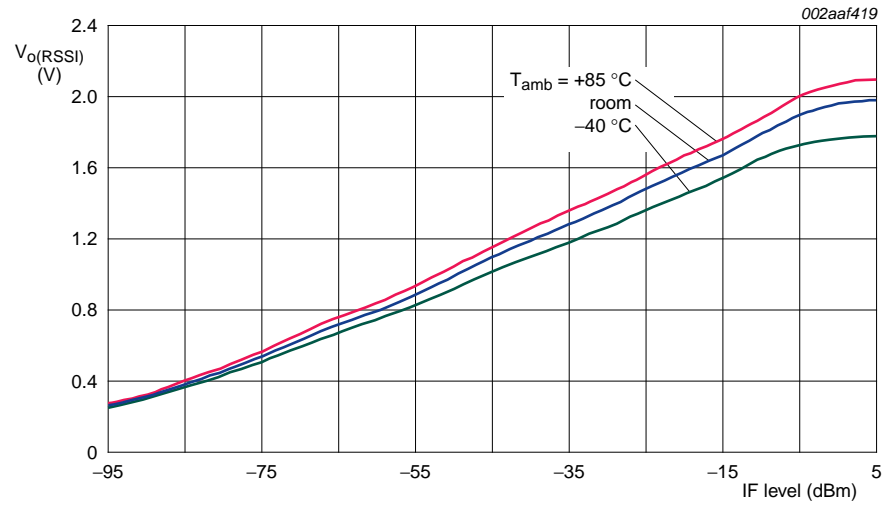

455 kHz IF at 3 V.

Fig 13. RSSI output voltage versus IF level

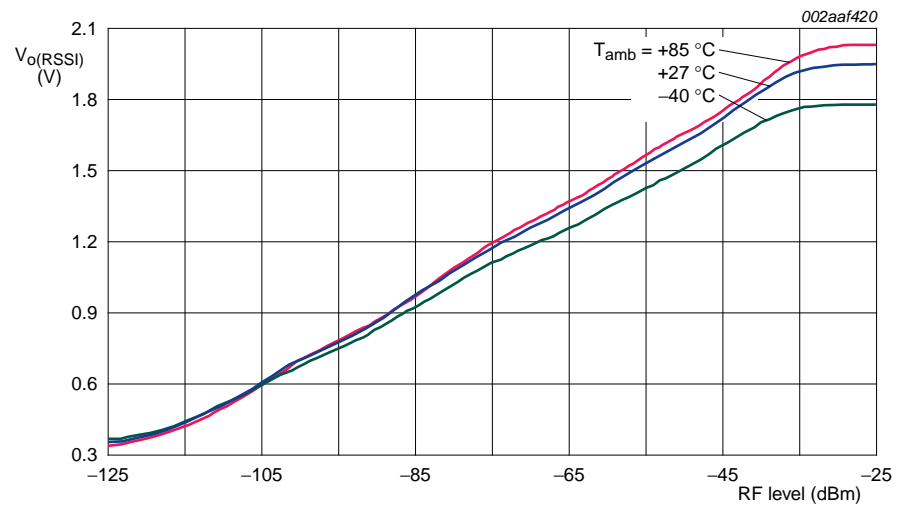

$V_{CC} = 3 V$

Fig 14. RSSI output voltage versus RF level

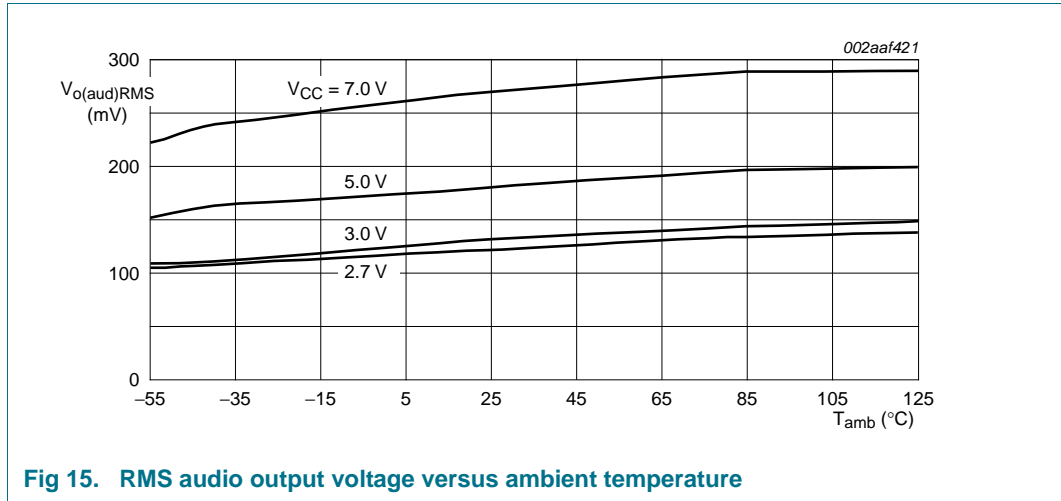
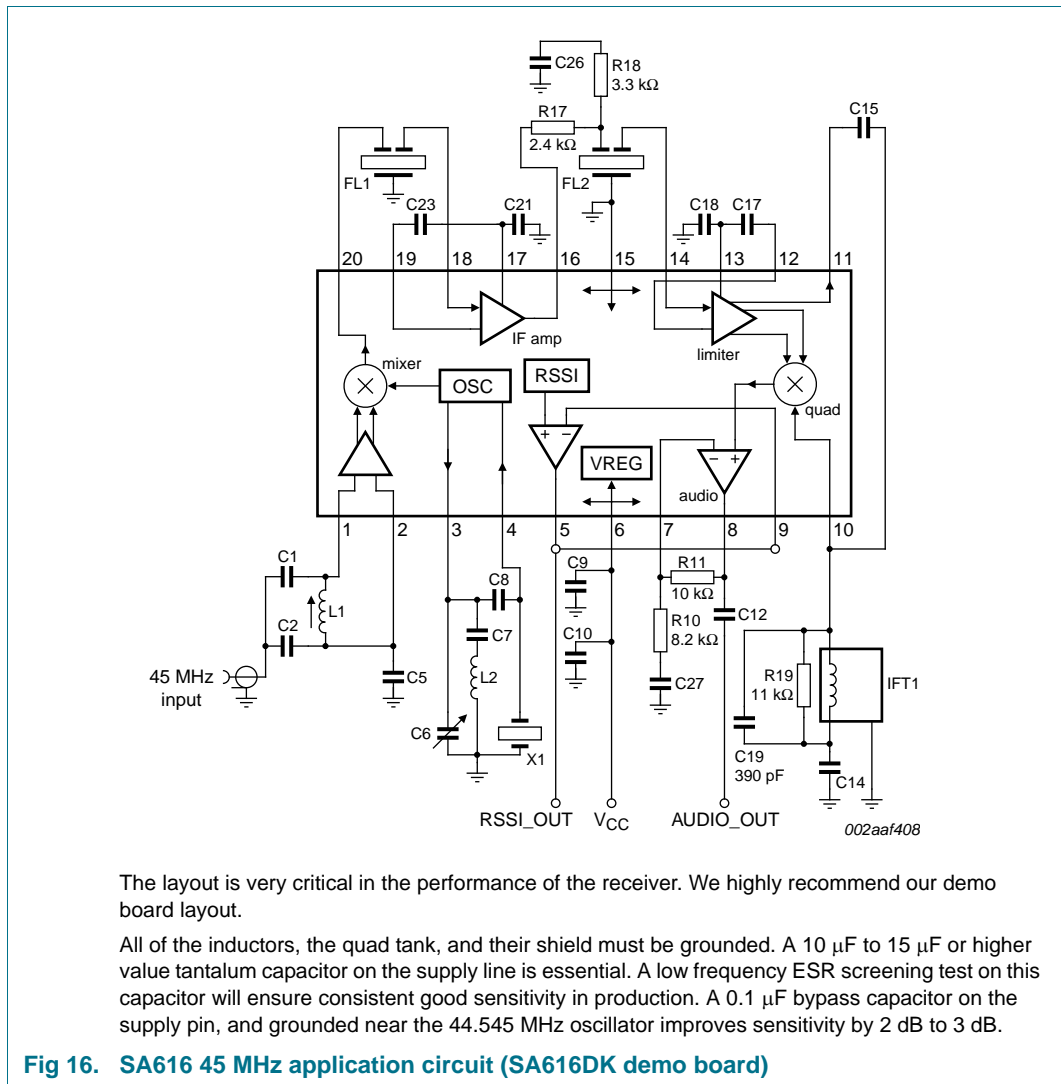

Fig 15. RMS audio output voltage versus ambient temperature

13. Application information



The layout is very critical in the performance of the receiver. We highly recommend our demo board layout.

All of the inductors, the quad tank, and their shield must be grounded. A 10 μ F to 15 μ F or higher value tantalum capacitor on the supply line is essential. A low frequency ESR screening test on this capacitor will ensure consistent good sensitivity in production. A 0.1 μ F bypass capacitor on the supply pin, and grounded near the 44.545 MHz oscillator improves sensitivity by 2 dB to 3 dB.

Fig 16. SA616 45 MHz application circuit (SA616DK demo board)

Table 7. SA616DK demo board component list

| Component | Description |
|--------------------------------------|--|
| C1 | 51 pF NPO ceramic |
| C2 | 220 pF NPO ceramic |
| C5, C9, C14, C17, C18, C21, C23, C26 | 100 nF \pm 10 % monolithic ceramic |
| C6 | 30 pF trim cap |
| C7 | 1 nF ceramic |
| C8, C15 | 10.0 pF NPO ceramic |
| C10 | 15 μ F tantalum (minimum) |
| C12 | 2.2 μ F \pm 10 % tantalum |
| C19 | 390 pF \pm 10 % monolithic ceramic |
| C27 | 2.2 μ F tantalum |
| FL1, FL2 ^[1] | ceramic filter Murata SFG455A3 or equivalent |
| IFT1 | 330 μ H Toko 836AN-0129Z |
| L1 | 0.33 μ H Toko A638AN-0158Z |
| L2 | 1.2 μ H Toko FSLM2520-1R2K |
| X1 | 44.545 MHz crystal ICM4712701 |
| R5 ^[2] | not used in application board |
| R10 | 8.2 k Ω \pm 5 % 1/4W carbon composition |
| R11 | 10 k Ω \pm 5 % 1/4W carbon composition |
| R17 | 2.4 k Ω \pm 5 % 1/4W carbon composition |
| R18 | 3.3 k Ω \pm 5 % 1/4W carbon composition |
| R19 | 11 k Ω \pm 5 % 1/4W carbon composition |

[1] The ceramic filters can be 30 kHz SFG455A3s made by Murata that have 30 kHz IF bandwidth (they come in blue), or 16 kHz CFU455Ds, also made by Murata (they come in black). All of our specifications and testing are done with the more wide-band filter.

[2] R5 can be used to bias the oscillator transistor at a higher current for operation above 45 MHz. Recommended value is 22 k Ω , but should not be below 10 k Ω .

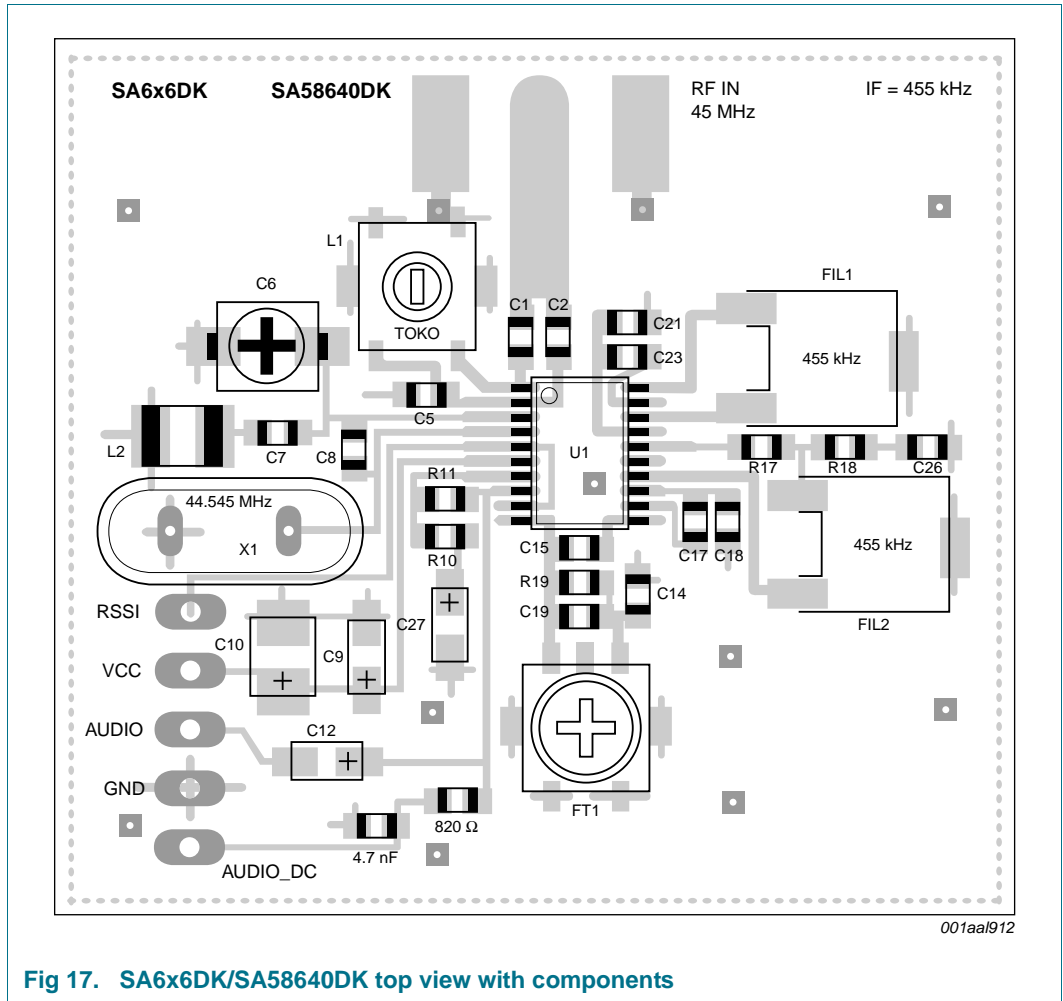
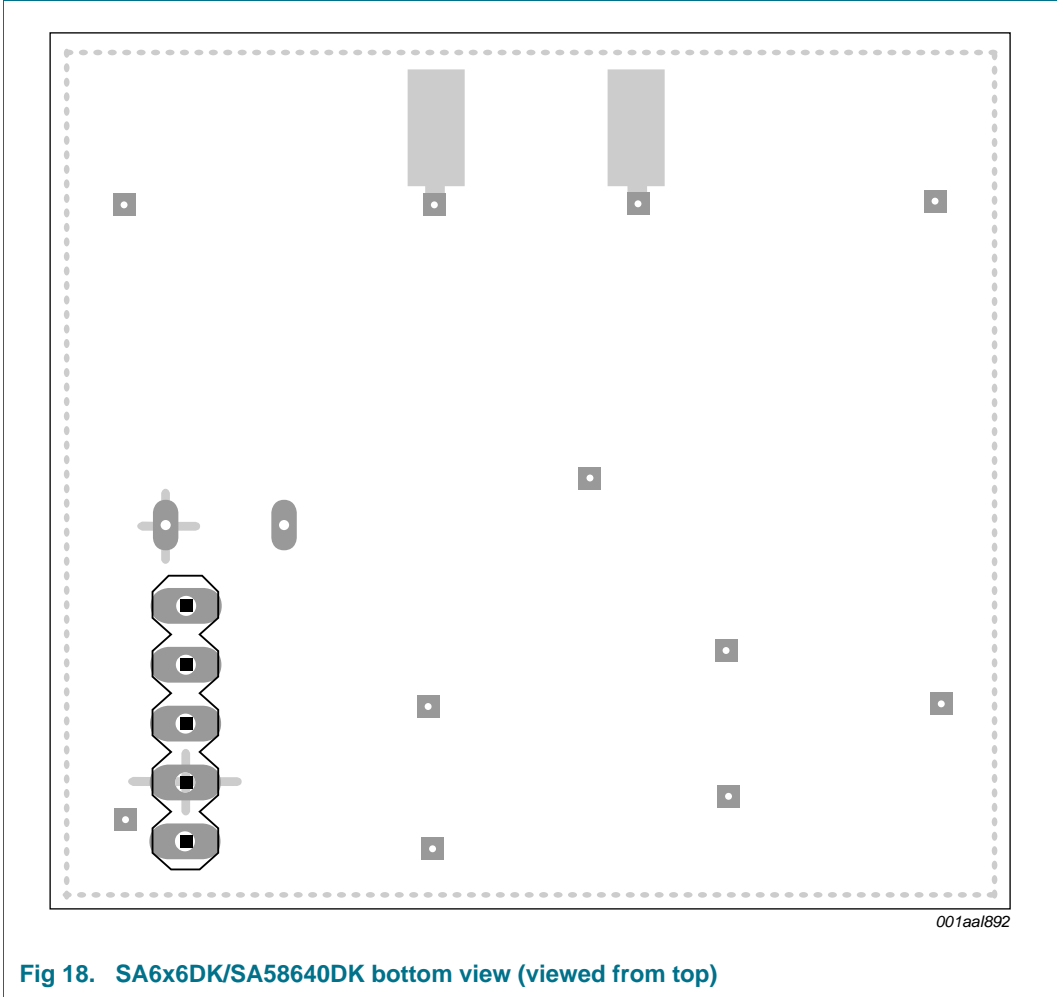

Fig 17. SA6x6DK/SA58640DK top view with components



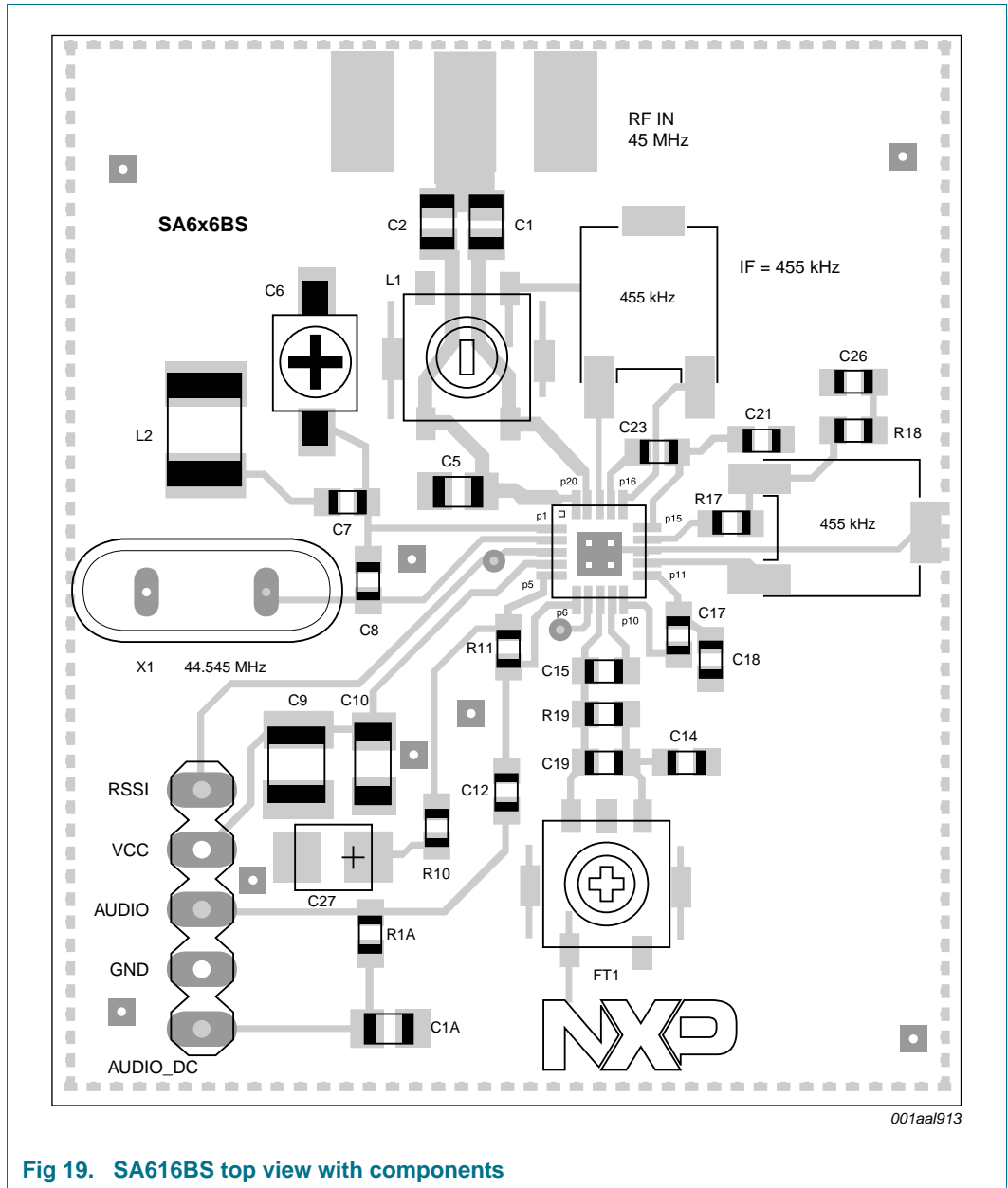
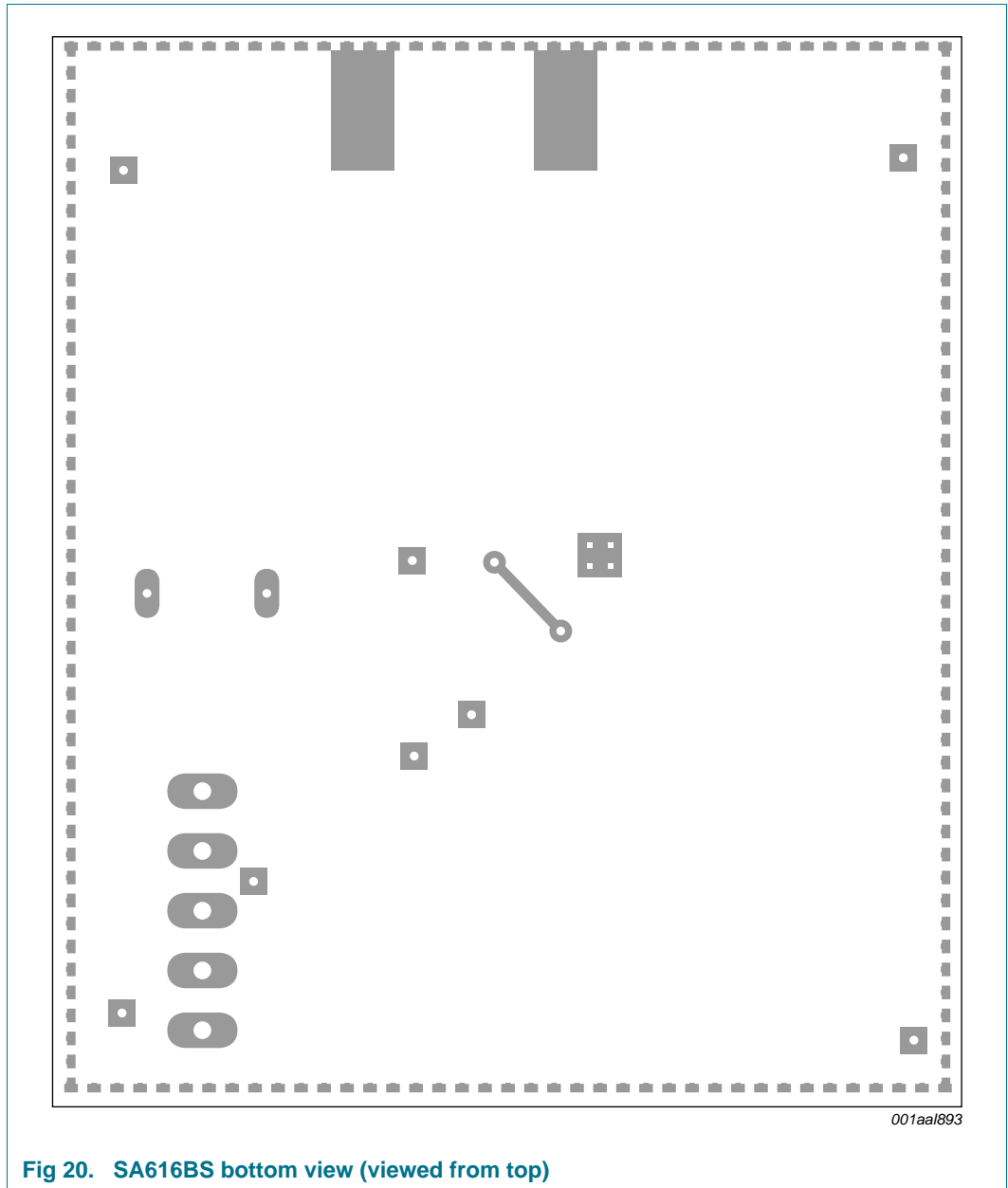

Fig 19. SA616BS top view with components



14. Test information

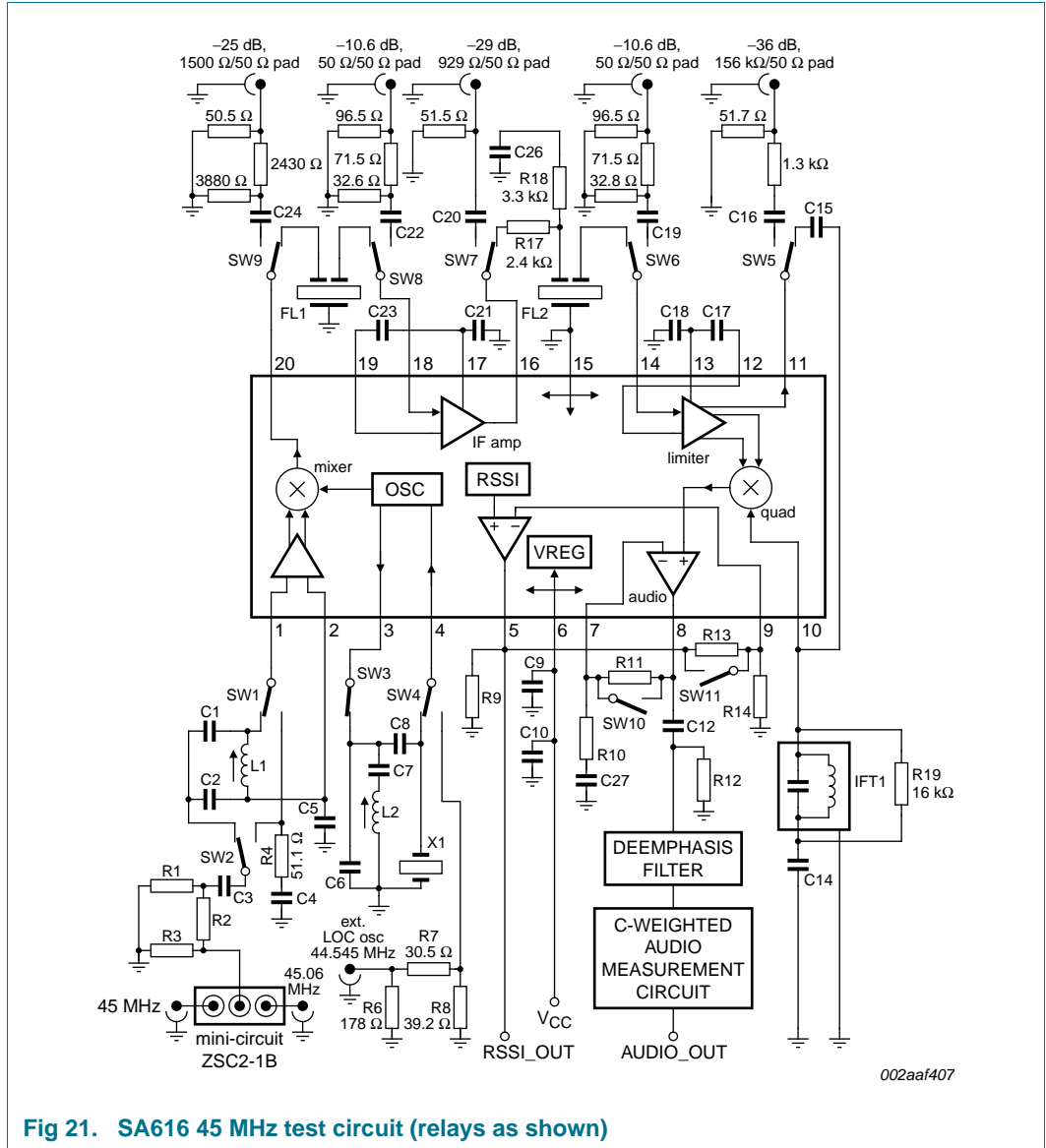
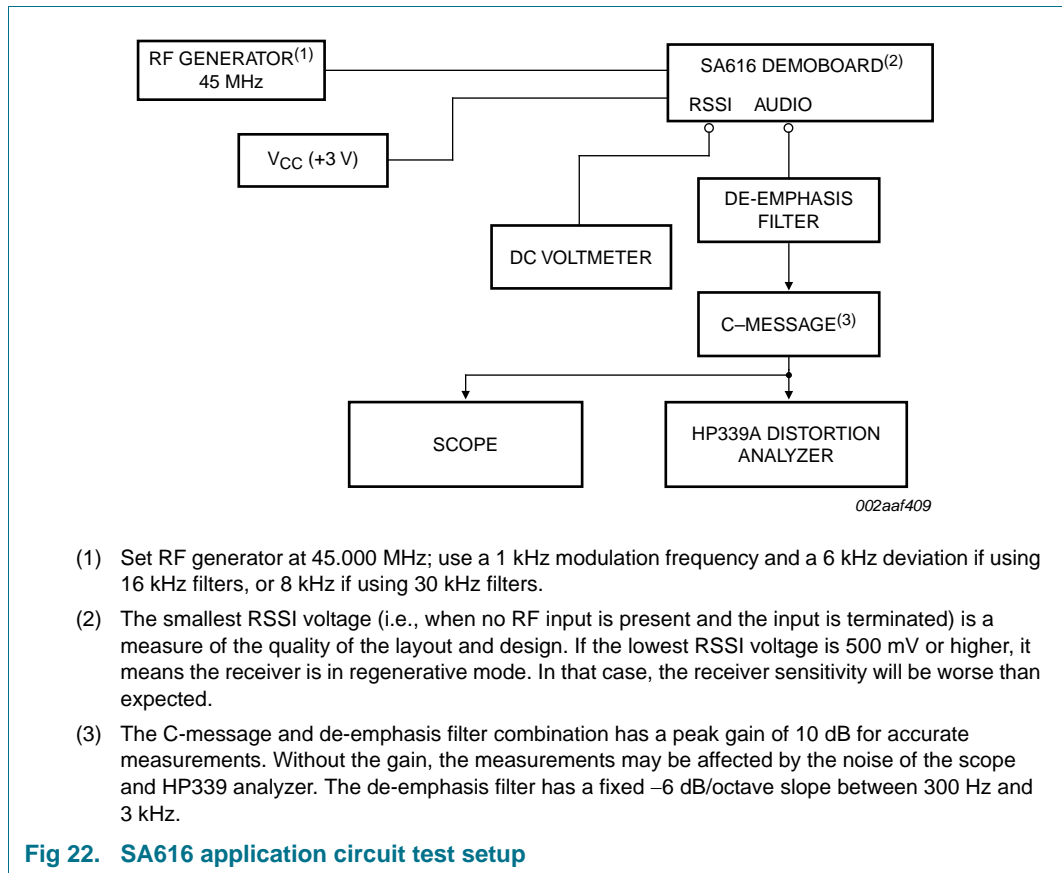

Fig 21. SA616 45 MHz test circuit (relays as shown)

Table 8. Automatic test circuit component list

| Component | Description |
|--|---|
| C1 | 100 pF NPO ceramic |
| C2 | 390 pF NPO ceramic |
| C5, C9, C14, C17, C18, C21, C23, C25, C26, C27 | 100 nF \pm 10 % monolithic ceramic |
| C6 | 22 pF NPO ceramic |
| C7 | 1 nF ceramic |
| C8, C15 | 10 pF NPO ceramic |
| C10 | 15 μ F tantalum (minimum) |
| C12 | 2.2 μ F |
| FL1, FL2 | ceramic filter, Murata SFG455A3 or equivalent |
| IFT1 | 455 kHz (C_e = 180 pF) Toko RMC-2A6597H |
| L1 | 147 nH to 160 nH Coilcraft UNI-10/142-04J08S |
| L2 | 0.8 μ H nominal; Toko 292CNS-T1038Z |
| R9 | 2 k Ω \pm 1 % 1/4 W metal film |
| R10 | 8.2 k Ω \pm 1 % |
| R11, R14 | 10 k Ω \pm 1 % |
| R12 | 2 k Ω \pm 1 % |
| R13 | 20 k Ω \pm 1 % |
| R17 | 2.4 k Ω \pm 5 % 1/4 W carbon composition |
| R18 | 3.3 k Ω |
| R19 | 16 k Ω |
| X1 | 44.545 MHz crystal ICM4712701 |



15. Package outline

SSOP20: plastic shrink small outline package; 20 leads; body width 4.4 mm

SOT266-1

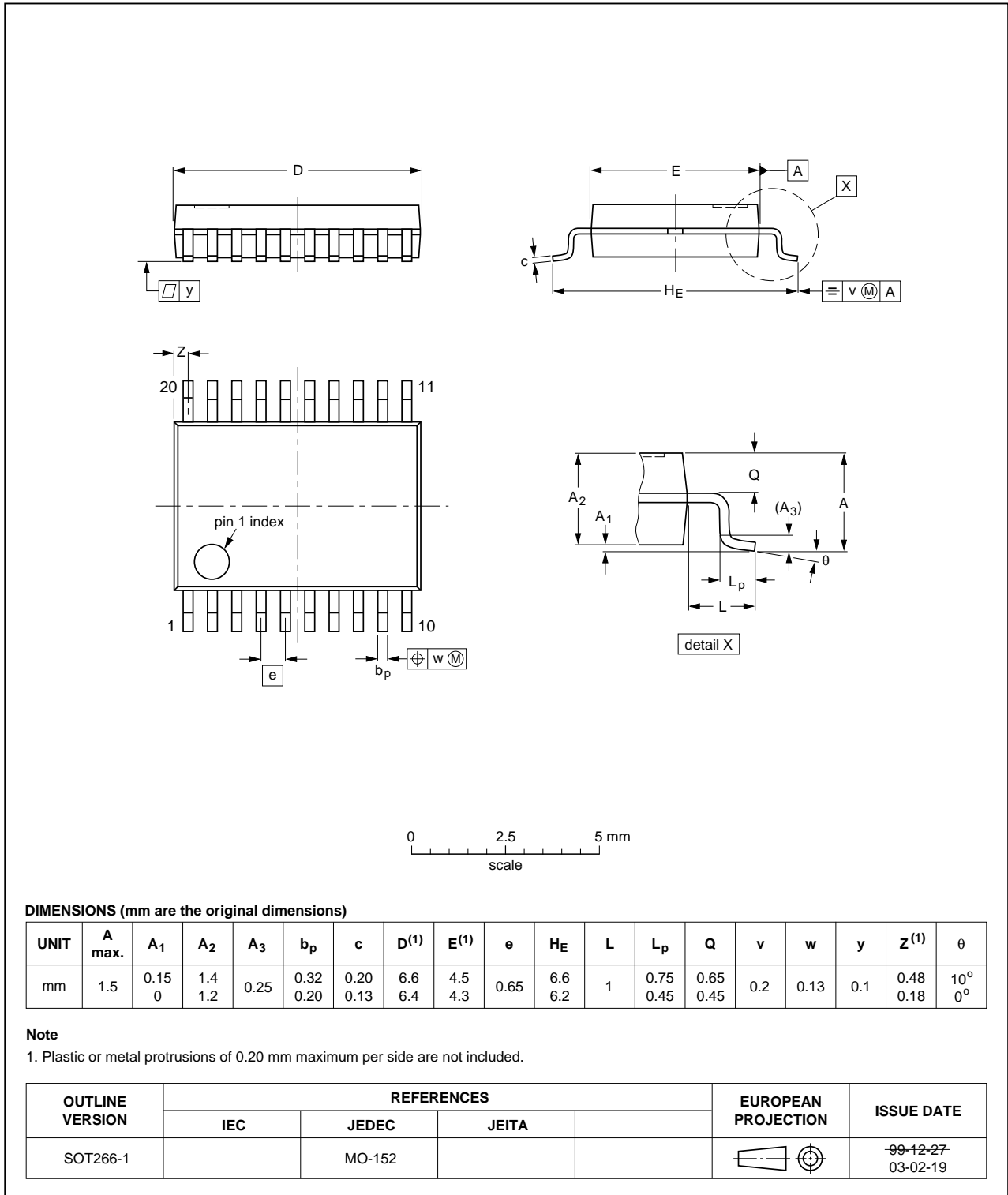

Fig 23. Package outline SOT266-1 (SSOP20)

HVQFN20: plastic thermal enhanced very thin quad flat package; no leads;
20 terminals; body 4 x 4 x 0.85 mm

SOT917-1

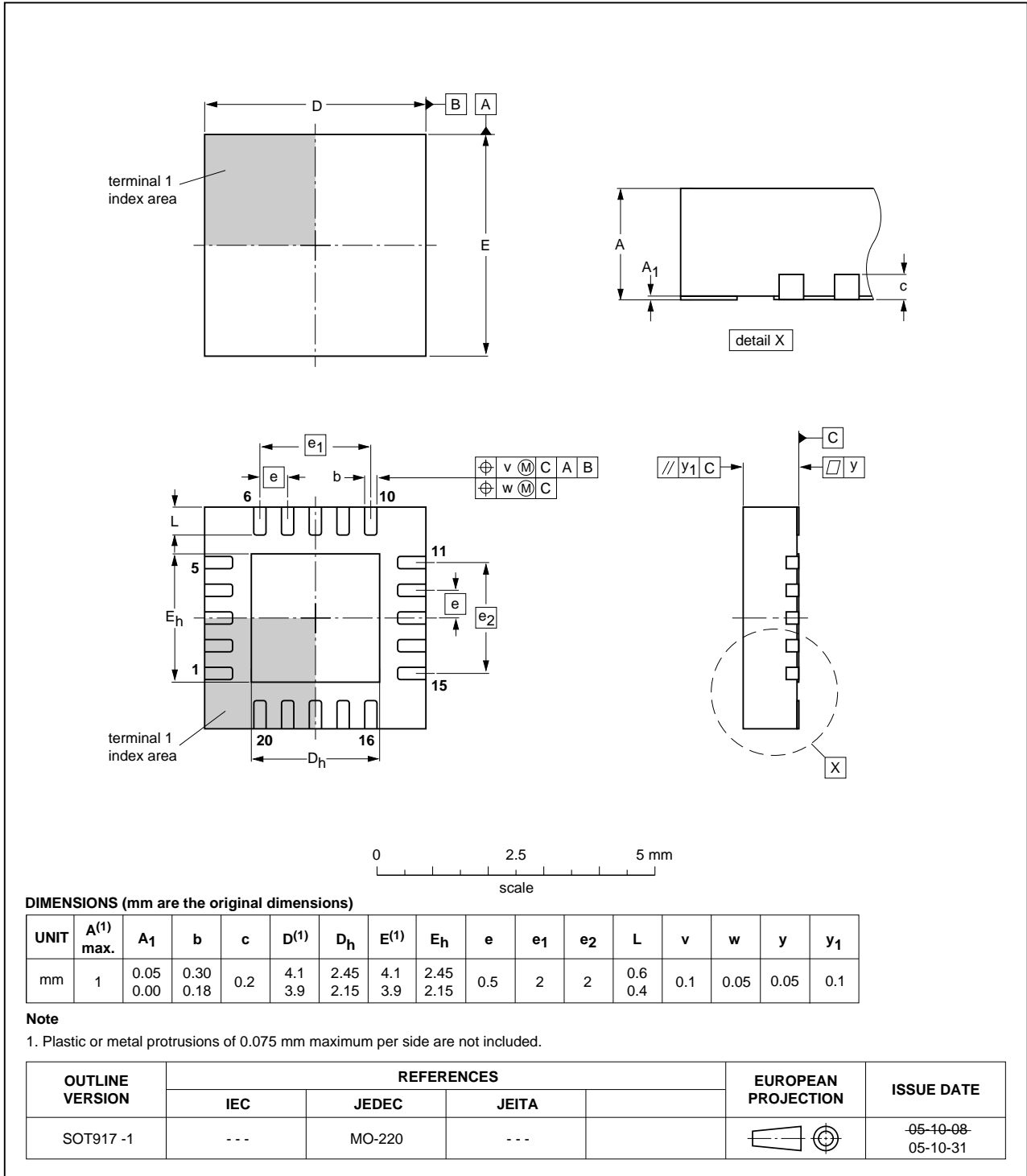

Fig 24. Package outline SOT917-1 (HVQFN20)

16. Soldering of SMD packages

This text provides a very brief insight into a complex technology. A more in-depth account of soldering ICs can be found in Application Note *AN10365 "Surface mount reflow soldering description"*.

16.1 Introduction to soldering

Soldering is one of the most common methods through which packages are attached to Printed Circuit Boards (PCBs), to form electrical circuits. The soldered joint provides both the mechanical and the electrical connection. There is no single soldering method that is ideal for all IC packages. Wave soldering is often preferred when through-hole and Surface Mount Devices (SMDs) are mixed on one printed wiring board; however, it is not suitable for fine pitch SMDs. Reflow soldering is ideal for the small pitches and high densities that come with increased miniaturization.

16.2 Wave and reflow soldering

Wave soldering is a joining technology in which the joints are made by solder coming from a standing wave of liquid solder. The wave soldering process is suitable for the following:

- Through-hole components
- Leaded or leadless SMDs, which are glued to the surface of the printed circuit board

Not all SMDs can be wave soldered. Packages with solder balls, and some leadless packages which have solder lands underneath the body, cannot be wave soldered. Also, leaded SMDs with leads having a pitch smaller than ~0.6 mm cannot be wave soldered, due to an increased probability of bridging.

The reflow soldering process involves applying solder paste to a board, followed by component placement and exposure to a temperature profile. Leaded packages, packages with solder balls, and leadless packages are all reflow solderable.

Key characteristics in both wave and reflow soldering are:

- Board specifications, including the board finish, solder masks and vias
- Package footprints, including solder thieves and orientation
- The moisture sensitivity level of the packages
- Package placement
- Inspection and repair
- Lead-free soldering versus SnPb soldering

16.3 Wave soldering

Key characteristics in wave soldering are:

- Process issues, such as application of adhesive and flux, clinching of leads, board transport, the solder wave parameters, and the time during which components are exposed to the wave
- Solder bath specifications, including temperature and impurities

16.4 Reflow soldering

Key characteristics in reflow soldering are:

- Lead-free versus SnPb soldering; note that a lead-free reflow process usually leads to higher minimum peak temperatures (see [Figure 25](#)) than a SnPb process, thus reducing the process window
- Solder paste printing issues including smearing, release, and adjusting the process window for a mix of large and small components on one board
- Reflow temperature profile; this profile includes preheat, reflow (in which the board is heated to the peak temperature) and cooling down. It is imperative that the peak temperature is high enough for the solder to make reliable solder joints (a solder paste characteristic). In addition, the peak temperature must be low enough that the packages and/or boards are not damaged. The peak temperature of the package depends on package thickness and volume and is classified in accordance with [Table 9](#) and [10](#)

Table 9. SnPb eutectic process (from J-STD-020C)

| Package thickness (mm) | Package reflow temperature (°C) | |
|------------------------|---------------------------------|-------|
| | Volume (mm ³) | |
| | < 350 | ≥ 350 |
| < 2.5 | 235 | 220 |
| ≥ 2.5 | 220 | 220 |

Table 10. Lead-free process (from J-STD-020C)

| Package thickness (mm) | Package reflow temperature (°C) | | |
|------------------------|---------------------------------|-------------|--------|
| | Volume (mm ³) | | |
| | < 350 | 350 to 2000 | > 2000 |
| < 1.6 | 260 | 260 | 260 |
| 1.6 to 2.5 | 260 | 250 | 245 |
| > 2.5 | 250 | 245 | 245 |

Moisture sensitivity precautions, as indicated on the packing, must be respected at all times.

Studies have shown that small packages reach higher temperatures during reflow soldering, see [Figure 25](#).

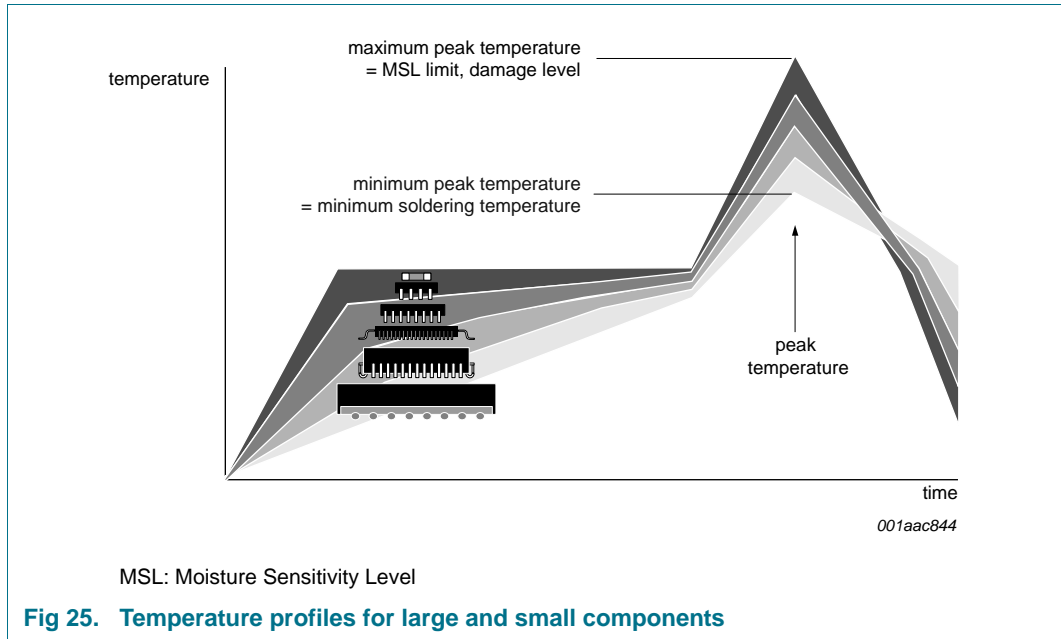

For further information on temperature profiles, refer to Application Note AN10365 “Surface mount reflow soldering description”.

17. Abbreviations

Table 11. Abbreviations

| Acronym | Description |
|---------|--------------------------------------|
| AM | Amplitude Modulation |
| AMP | Active Monitor Present |
| ASK | Amplitude Shift Keying |
| ESD | ElectroStatic Discharge |
| ESR | Equivalent Series Resistance |
| FM | Frequency Modulation |
| FSK | Frequency Shift Keying |
| IF | Intermediate Frequency |
| LC | inductor/capacitor filter |
| LO | Local Oscillator |
| PCB | Printed-Circuit Board |
| RF | Radio Frequency |
| RMS | Root Mean Squared |
| RSSI | Received Signal Strength Indicator |
| SINAD | Signal-to-Noise And Distortion ratio |
| TAC | Telenet Access Controller |
| VHF | Very High Frequency |

18. Revision history

Table 12. Revision history

| Document ID | Release date | Data sheet status | Change notice | Supersedes |
|----------------|--|-----------------------|--------------------------------------|------------|
| SA616 v.3 | 20100621 | Product data sheet | - | SA616_2 |
| Modifications: | <ul style="list-style-type: none"> • The format of this data sheet has been redesigned to comply with the new identity guidelines of NXP Semiconductors. • Legal texts have been adapted to the new company name where appropriate. • Added HVQFN20 package. • Symbol and Parameter definitions are updated to new NXP presentation standards. • Moved $Z_{th(j-a)}$ specification from Table 3 "Limiting values" to (new) Table 4 "Thermal characteristics" • Table 7 "SA616DK demo board component list": <ul style="list-style-type: none"> – component IFT1 changed from "303LN-1130" to "836AN-01297Z" – component L1 changed from "SCB-1320Z" to "A638AN-0158Z" – component L2: appended "Toko FSLM2520-1R2K" • (Old) Figure 18 replaced with Figure 17 "SA6x6DK/SA58640DK top view with components" and Figure 18 "SA6x6DK/SA58640DK bottom view (viewed from top)". • Added Figure 19 "SA616BS top view with components" and Figure 20 "SA616BS bottom view (viewed from top)". | | | |
| SA616_2 | 19971107 | Product specification | ECN 853-1676 18665 dated 1997 Nov 07 | SA616_1 |
| SA616_1 | 19931215 | Product specification | ECN 853-1676 11649 dated 1993 Dec 15 | - |

19. Legal information

19.1 Data sheet status

| Document status ^{[1][2]} | Product status ^[3] | Definition |
|-----------------------------------|-------------------------------|---|
| Objective [short] data sheet | Development | This document contains data from the objective specification for product development. |
| Preliminary [short] data sheet | Qualification | This document contains data from the preliminary specification. |
| Product [short] data sheet | Production | This document contains the product specification. |

[1] Please consult the most recently issued document before initiating or completing a design.

[2] The term 'short data sheet' is explained in section "Definitions".

[3] The product status of device(s) described in this document may have changed since this document was published and may differ in case of multiple devices. The latest product status information is available on the Internet at URL <http://www.nxp.com>.

19.2 Definitions

Draft — The document is a draft version only. The content is still under internal review and subject to formal approval, which may result in modifications or additions. NXP Semiconductors does not give any representations or warranties as to the accuracy or completeness of information included herein and shall have no liability for the consequences of use of such information.

Short data sheet — A short data sheet is an extract from a full data sheet with the same product type number(s) and title. A short data sheet is intended for quick reference only and should not be relied upon to contain detailed and full information. For detailed and full information see the relevant full data sheet, which is available on request via the local NXP Semiconductors sales office. In case of any inconsistency or conflict with the short data sheet, the full data sheet shall prevail.

Product specification — The information and data provided in a Product data sheet shall define the specification of the product as agreed between NXP Semiconductors and its customer, unless NXP Semiconductors and customer have explicitly agreed otherwise in writing. In no event however, shall an agreement be valid in which the NXP Semiconductors product is deemed to offer functions and qualities beyond those described in the Product data sheet.

19.3 Disclaimers

Limited warranty and liability — Information in this document is believed to be accurate and reliable. However, NXP Semiconductors does not give any representations or warranties, expressed or implied, as to the accuracy or completeness of such information and shall have no liability for the consequences of use of such information.

In no event shall NXP Semiconductors be liable for any indirect, incidental, punitive, special or consequential damages (including - without limitation - lost profits, lost savings, business interruption, costs related to the removal or replacement of any products or rework charges) whether or not such damages are based on tort (including negligence), warranty, breach of contract or any other legal theory.

Notwithstanding any damages that customer might incur for any reason whatsoever, NXP Semiconductors' aggregate and cumulative liability towards customer for the products described herein shall be limited in accordance with the *Terms and conditions of commercial sale* of NXP Semiconductors.

Right to make changes — NXP Semiconductors reserves the right to make changes to information published in this document, including without limitation specifications and product descriptions, at any time and without notice. This document supersedes and replaces all information supplied prior to the publication hereof.

Suitability for use — NXP Semiconductors products are not designed, authorized or warranted to be suitable for use in life support, life-critical or safety-critical systems or equipment, nor in applications where failure or

malfunction of an NXP Semiconductors product can reasonably be expected to result in personal injury, death or severe property or environmental damage. NXP Semiconductors accepts no liability for inclusion and/or use of NXP Semiconductors products in such equipment or applications and therefore such inclusion and/or use is at the customer's own risk.

Applications — Applications that are described herein for any of these products are for illustrative purposes only. NXP Semiconductors makes no representation or warranty that such applications will be suitable for the specified use without further testing or modification.

Customers are responsible for the design and operation of their applications and products using NXP Semiconductors products, and NXP Semiconductors accepts no liability for any assistance with applications or customer product design. It is customer's sole responsibility to determine whether the NXP Semiconductors product is suitable and fit for the customer's applications and products planned, as well as for the planned application and use of customer's third party customer(s). Customers should provide appropriate design and operating safeguards to minimize the risks associated with their applications and products.

NXP Semiconductors does not accept any liability related to any default, damage, costs or problem which is based on any weakness or default in the customer's applications or products, or the application or use by customer's third party customer(s). Customer is responsible for doing all necessary testing for the customer's applications and products using NXP Semiconductors products in order to avoid a default of the applications and the products or of the application or use by customer's third party customer(s). NXP does not accept any liability in this respect.

Limiting values — Stress above one or more limiting values (as defined in the Absolute Maximum Ratings System of IEC 60134) will cause permanent damage to the device. Limiting values are stress ratings only and (proper) operation of the device at these or any other conditions above those given in the Recommended operating conditions section (if present) or the Characteristics sections of this document is not warranted. Constant or repeated exposure to limiting values will permanently and irreversibly affect the quality and reliability of the device.

Terms and conditions of commercial sale — NXP Semiconductors products are sold subject to the general terms and conditions of commercial sale, as published at <http://www.nxp.com/profile/terms>, unless otherwise agreed in a valid written individual agreement. In case an individual agreement is concluded only the terms and conditions of the respective agreement shall apply. NXP Semiconductors hereby expressly objects to applying the customer's general terms and conditions with regard to the purchase of NXP Semiconductors products by customer.

No offer to sell or license — Nothing in this document may be interpreted or construed as an offer to sell products that is open for acceptance or the grant, conveyance or implication of any license under any copyrights, patents or other industrial or intellectual property rights.

Export control — This document as well as the item(s) described herein may be subject to export control regulations. Export might require a prior authorization from national authorities.

Non-automotive qualified products — Unless this data sheet expressly states that this specific NXP Semiconductors product is automotive qualified, the product is not suitable for automotive use. It is neither qualified nor tested in accordance with automotive testing or application requirements. NXP Semiconductors accepts no liability for inclusion and/or use of non-automotive qualified products in automotive equipment or applications.

In the event that customer uses the product for design-in and use in automotive applications to automotive specifications and standards, customer (a) shall use the product without NXP Semiconductors' warranty of the product for such automotive applications, use and specifications, and (b) whenever customer uses the product for automotive applications beyond

NXP Semiconductors' specifications such use shall be solely at customer's own risk, and (c) customer fully indemnifies NXP Semiconductors for any liability, damages or failed product claims resulting from customer design and use of the product for automotive applications beyond NXP Semiconductors' standard warranty and NXP Semiconductors' product specifications.

19.4 Trademarks

Notice: All referenced brands, product names, service names and trademarks are the property of their respective owners.

20. Contact information

For more information, please visit: <http://www.nxp.com>

For sales office addresses, please send an email to: salesaddresses@nxp.com

21. Contents

| | | |
|-----------|--|-----------|
| 1 | General description | 1 |
| 2 | Features and benefits | 1 |
| 3 | Applications | 1 |
| 4 | Ordering information | 2 |
| 5 | Block diagram | 2 |
| 6 | Pinning information | 3 |
| 6.1 | Pinning | 3 |
| 6.2 | Pin description | 4 |
| 7 | Functional description | 5 |
| 8 | Limiting values | 6 |
| 9 | Thermal characteristics | 6 |
| 10 | Static characteristics | 6 |
| 11 | Dynamic characteristics | 7 |
| 12 | Performance curves | 8 |
| 13 | Application information | 14 |
| 14 | Test information | 20 |
| 15 | Package outline | 23 |
| 16 | Soldering of SMD packages | 25 |
| 16.1 | Introduction to soldering | 25 |
| 16.2 | Wave and reflow soldering | 25 |
| 16.3 | Wave soldering | 25 |
| 16.4 | Reflow soldering | 26 |
| 17 | Abbreviations | 27 |
| 18 | Revision history | 28 |
| 19 | Legal information | 29 |
| 19.1 | Data sheet status | 29 |
| 19.2 | Definitions | 29 |
| 19.3 | Disclaimers | 29 |
| 19.4 | Trademarks | 30 |
| 20 | Contact information | 30 |
| 21 | Contents | 31 |

Please be aware that important notices concerning this document and the product(s) described herein, have been included in section 'Legal information'.

© NXP B.V. 2010.

All rights reserved.

For more information, please visit: <http://www.nxp.com>

For sales office addresses, please send an email to: salesaddresses@nxp.com

Date of release: 21 June 2010

Document identifier: SA616