

# S6A0090

64 SEG / 26 COM DRIVER & CONTROLLER FOR STN LCD

June. 2000.

Ver. 0.2

Prepared by: Weon-seek, Kang

[k2w2@samsung.co.kr](mailto:k2w2@samsung.co.kr)

Contents in this document are subject to change without notice. No part of this document may be reproduced or transmitted in any form or by any means, electronic or mechanical, for any purpose, without the express written permission of LCD Driver IC Team.

<b>S6A0090 Specification Revision History</b>		
<b>Version</b>	<b>Content</b>	<b>Date</b>
0.0	Original	Jun.1998
0.1	KS0090 → KS0090B, add ILB key	Apr.1999
0.2	Add power ON / OFF sequence	Apr.1999
	Inspection	Jun.2000

# CONTENTS

<b>INTRODUCTION</b> .....	<b>1</b>
<b>FEATURES</b> .....	<b>1</b>
<b>BLOCK DIAGRAM</b> .....	<b>3</b>
<b>PAD CONFIGURATION</b> .....	<b>4</b>
<b>PAD CENTER COORDINATES</b> .....	<b>5</b>
<b>PIN DESCRIPTION</b> .....	<b>7</b>
POWER SUPPLY .....	7
LCD DRIVER SUPPLY .....	7
SYSTEM CONTROL .....	8
MPU INTERFACE .....	8
LCD DRIVER OUTPUTS (DYNAMIC).....	9
LCD DRIVER OUTPUTS (STATIC) .....	9
<b>FUNCTION DESCRIPTION</b> .....	<b>10</b>
SYSTEM INTERFACE.....	10
ADDRESS COUNTER (AC).....	14
DISPLAY DATA RAM (DDRAM).....	14
CHARACTER GENERATOR ROM (CGROM) .....	15
CHARACTER GENERATOR RAM (CGRAM) .....	16
SEGMENT ICON RAM (ICONRAM) .....	17
STATIC ICON RAM (SI) .....	18
SEGMENTS FOR SIGNAL DISPLAY (FS).....	18
LOW POWER CONSUMPTION MODE .....	19
LCD DRIVER CIRCUIT .....	19
<b>INSTRUCTION DESCRIPTION</b> .....	<b>20</b>
<b>INITIALIZING &amp; POWER SAVE MODE SETUP</b> .....	<b>26</b>
HARDWARE RESET .....	26
INITIALIZING AND POWER SAVE MODE SETUP .....	27
<b>LCD DRIVING POWER SUPPLY CIRCUIT</b> .....	<b>30</b>
VOLTAGE CONVERTER .....	31
VOLTAGE REGULATOR.....	32
VOLTAGE GENERATOR CIRCUIT .....	35
<b>REFERENCE APPLICATIONS</b> .....	<b>36</b>
MPU INTERFACE .....	36
APPLICATION INFORMATION FOR LCD PANEL.....	38
FRAME FREQUENCY.....	42
<b>MAXIMUM ABSOLUTE RATINGS</b> .....	<b>43</b>
<b>ELECTRICAL CHARACTERISTICS</b> .....	<b>44</b>
DC CHARACTERISTICS.....	44
AC CHARACTERISTICS.....	47



## INTRODUCTION

The S6A0090 is an LCD driver and controller LSI for liquid crystal dot matrix character display systems. It can display 2 or 3 lines of 12 characters with 5 x 8 dots format. It is capable of interfacing with various microprocessors, supporting the 4-bit and 8-bit parallel mode and the clock synchronized serial mode. Voltage converter (2 or 3 times), voltage regulator, divider resistor and voltage follower OP AMP are built in the IC and a low operation current of 50 $\mu$ A is achieved. The slim shape of the chip makes it suitable for the COG module application and TCP. The S6A0090 is an ideal solution for display on portable equipment such as cellular phones.

## FEATURES

### Driver Outputs

- Common outputs: 26 common
- Segment outputs: 64 segment
- Icons: 128 horizontal icons, 24 x 4 vertical icons, 5 static icons

### Applicable Panel Size

Display size	Duty	Contents of outputs
2-line x 12 characters	1/18	(12 characters + 4 segments for signal) x 2 + 128 icons + 5 static icons
3-line x 12 characters	1/26	(12 characters + 4 segments for signal) x 3 + 128 icons + 5 static icons

### Internal Memory

- Character Generator ROM (CGROM): 10,240 bits (256 characters x 5 x 8 dots)
- Character Generator RAM (CGRAM): 160 bits (4 characters x 5 x 8 dots)
- Display Data RAM (DDRAM): 288 bits (12 characters x 3 lines x 8 bits)
- Segment Icon RAM (ICONRAM): 224 bits (12 x 2 x 5 bits + 2 x 4 bits + 24 x 4 bits)

### MPU Interface

- No busy MPU interface (no busy check or no execution waiting time)
- 8-bit parallel interface mode: 68-series and 80-series are available
- 4-bit parallel interface mode: 68-series and 80-series are available
- Serial interface mode: 4 pins clock synchronized serial interface

### Function Set

- Various instructions set: display control, power save, power control, function set, etc.
- COM / SEG bi-directional function (4 types of LCD application available)
- Hardware reset (RES pin)

### Built-in Analog Circuit

- On-chip oscillator with an internal resistor or external clock input
- Electronic volume for contrast control (32 or 64 steps)
- Voltage converter (2 or 3 times) / voltage regulator / voltage follower and bias circuit

**Low Power Consumption**

- 80  $\mu$ A Max. : in normal mode for normal display operation
- 10  $\mu$ A Max. : in standby mode for displaying static icon
- 5  $\mu$ A Max. : in sleep mode when display is turned OFF

**Operating Voltage Range**

- Power supply voltage (VDD): 2.4 to 5.5 V
- LCD driving voltage (VLCD = V0 - Vss): 11.0 V (positive process)

**Package Type**

- Gold bumped chip or TCP

**BLOCK DIAGRAM**

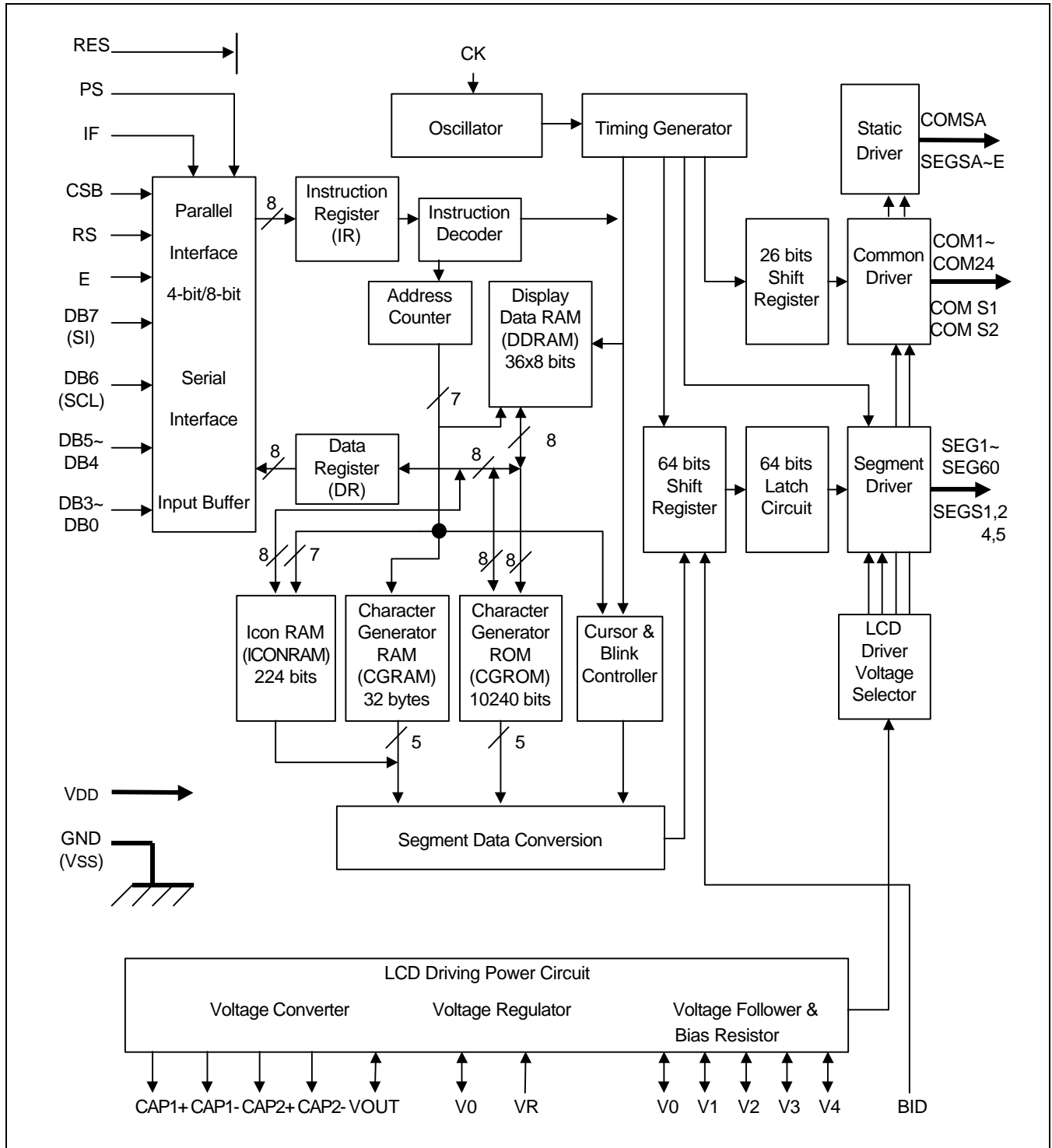

**Figure 1. Block Diagram**

### PAD CONFIGURATION

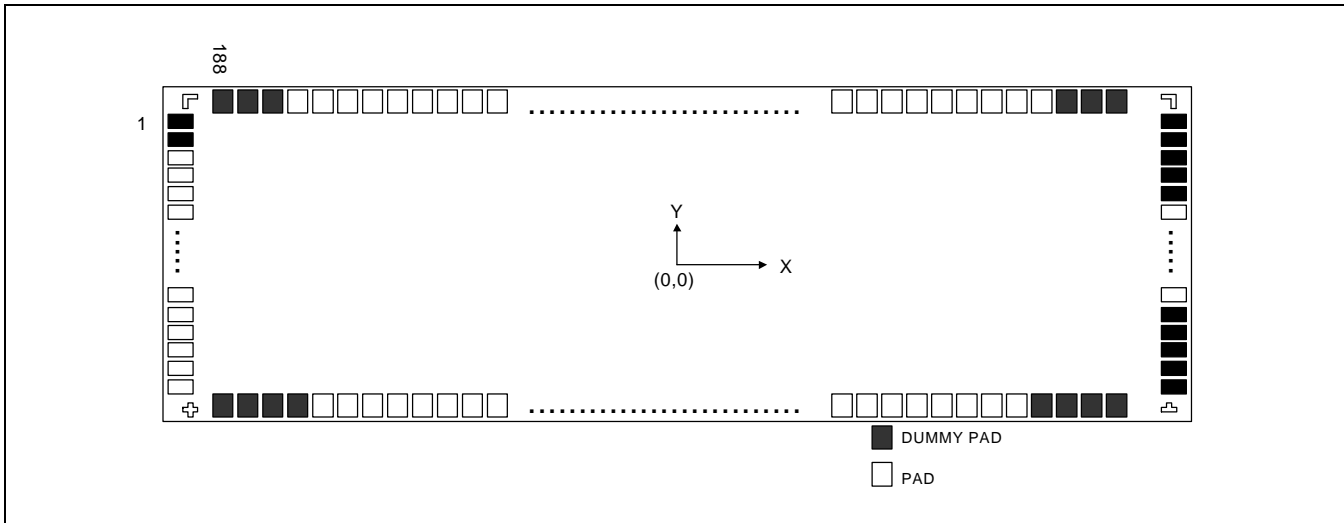
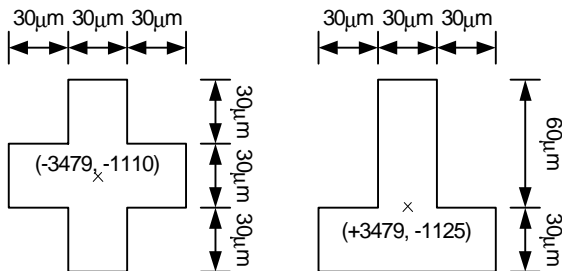

Figure 2. Pad Configuration

Table 1. S6A0090 Pad Dimensions

Item	Pad No. (location)	Size		Unit
		X	Y	
Chip size	-	7410	2470	μm
Pad size	1 to 188	60	118	
Bumped pad size	1 to 188	56	114	
Bumped pad height	1 to 188	17 ± 1.5		
Align key size	Left, right top	150	150	
	Left bottom	90	90	
	Right bottom	90	90	

#### COG Align Key Coordinate



#### ILB Align Key Coordinate

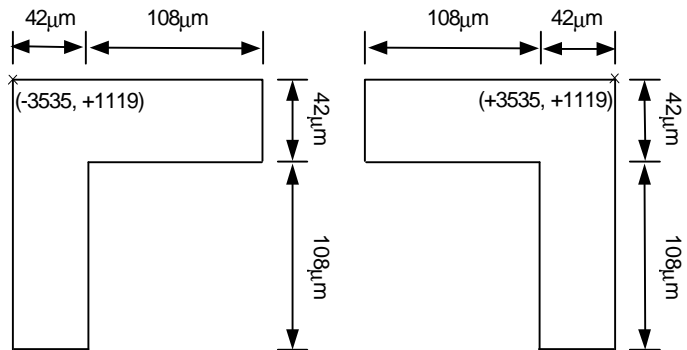



## PAD CENTER COORDINATES

Table 2. Pad Center Coordinates

[Unit:  $\mu\text{m}$ ]

Pad No.	Pad Name	Coordinate		Pad No.	Pad Name	Coordinate		Pad No.	Pad Name	Coordinate	
		X	Y			X	Y			X	Y
1	DUMMY	-3540	880	31	DB5	-2430	-1111	61	CAP2-	270	-1111
2	DUMMY	-3540	790	32	DB4	-2340	-1111	62	CAP2-	360	-1111
3	COM21	-3540	700	33	DB3	-2250	-1111	63	CAP2-	450	-1111
4	COM20	-3540	610	34	DB2	-2160	-1111	64	CAP2-	540	-1111
5	COM19	-3540	520	35	DB1	-2070	-1111	65	CAP2+	630	-1111
6	COM18	-3540	430	36	DB0	-1980	-1111	66	CAP2+	720	-1111
7	COM17	-3540	340	37	VDD	-1890	-1111	67	CAP2+	810	-1111
8	COM16	-3540	250	38	VDD	-1800	-1111	68	CAP2+	900	-1111
9	COM15	-3540	160	39	VDD	-1710	-1111	69	CAP1-	990	-1111
10	COM14	-3540	70	40	VSS	-1620	-1111	70	CAP1-	1080	-1111
11	COM13	-3540	-20	41	VSS	-1530	-1111	71	CAP1-	1170	-1111
12	COM12	-3540	-110	42	VSS	-1440	-1111	72	CAP1-	1260	-1111
13	COM11	-3540	-200	43	V4	-1350	-1111	73	CAP1+	1350	-1111
14	COM10	-3540	-290	44	V4	-1260	-1111	74	CAP1+	1440	-1111
15	COM9	-3540	-380	45	V3	-1170	-1111	75	CAP1+	1530	-1111
16	COMS2	-3540	-470	46	V3	-1080	-1111	76	CAP1+	1620	-1111
17	SEGSA	-3540	-560	47	V2	-990	-1111	77	VSS	1710	-1111
18	SEGSB	-3540	-650	48	V2	-900	-1111	78	VSS	1800	-1111
19	SEGSC	-3540	-740	49	V1	-810	-1111	79	VSS	1890	-1111
20	SEGSD	-3540	-830	50	V1	-720	-1111	80	BID	1980	-1111
21	SEGSE	-3540	-920	51	V0	-630	-1111	81	VDD	2070	-1111
22	DUMMY	-3240	-1111	52	V0	-540	-1111	82	VDD	2160	-1111
23	DUMMY	-3150	-1111	53	V0	-450	-1111	83	VDD	2250	-1111
24	DUMMY	-3060	-1111	54	V0	-360	-1111	84	CK	2340	-1111
25	DUMMY	-2970	-1111	55	VR	-270	-1111	85	VDD	2430	-1111
26	RS	-2880	-1111	56	VR	-180	-1111	86	PS	2520	-1111
27	E	-2790	-1111	57	VOUT	-90	-1111	87	IF	2610	-1111
28	CSB	-2700	-1111	58	VOUT	0	-1111	88	RES	2700	-1111
29	DB7	-2610	-1111	59	VOUT	90	-1111	89	VDD	2790	-1111
30	DB6	-2520	-1111	60	VOUT	180	-1111	90	VDD	2880	-1111

Table 2. Pad Center Coordinates (Continued)

[Unit: um]

Pad No.	Pad Name	Coordinate		Pad No.	Pad Name	Coordinate		Pad No.	Pad Name	Coordinate	
		X	Y			X	Y			X	Y
91	DUMMY	2970	-1111	124	SEG4	2520	1070	157	SEG37	-450	1070
92	DUMMY	3060	-1111	125	SEG5	2430	1070	158	SEG38	-540	1070
93	DUMMY	3150	-1111	126	SEG6	2340	1070	159	SEG39	-630	1070
94	DUMMY	3240	-1111	127	SEG7	2250	1070	160	SEG40	-720	1070
95	DUMMY	3540	-920	128	SEG8	2160	1070	161	SEG41	-810	1070
96	DUMMY	3540	-830	129	SEG9	2070	1070	162	SEG42	-900	1070
97	DUMMY	3540	-740	130	SEG10	1980	1070	163	SEG43	-990	1070
98	DUMMY	3540	-650	131	SEG11	1890	1070	164	SEG44	-1080	1070
99	DUMMY	3540	-560	132	SEG12	1800	1070	165	SEG45	-1170	1070
100	COMSA	3540	-470	133	SEG13	1710	1070	166	SEG46	-1260	1070
101	COMS1	3540	-380	134	SEG14	1620	1070	167	SEG47	-1350	1070
102	COM1	3540	-290	135	SEG15	1530	1070	168	SEG48	-1440	1070
103	COM2	3540	-200	136	SEG16	1440	1070	169	SEG49	-1530	1070
104	COM3	3540	-110	137	SEG17	1350	1070	170	SEG50	-1620	1070
105	COM4	3540	-20	138	SEG18	1260	1070	171	SEG51	-1710	1070
106	COM5	3540	70	139	SEG19	1170	1070	172	SEG52	-1800	1070
107	COM6	3540	160	140	SEG20	1080	1070	173	SEG53	-1890	1070
108	COM7	3540	250	141	SEG21	990	1070	174	SEG54	-1980	1070
109	COM8	3540	340	142	SEG22	900	1070	175	SEG55	-2070	1070
110	COMS1	3540	430	143	SEG23	810	1070	176	SEG56	-2160	1070
111	DUMMY	3540	520	144	SEG24	720	1070	177	SEG57	-2250	1070
112	DUMMY	3540	610	145	SEG25	630	1070	178	SEG58	-2340	1070
113	DUMMY	3540	700	146	SEG26	540	1070	179	SEG59	-2430	1070
114	DUMMY	3540	790	147	SEG27	450	1070	180	SEG60	-2520	1070
115	DUMMY	3540	880	148	SEG28	360	1070	181	SEGS4	-2610	1070
116	DUMMY	3240	1070	149	SEG29	270	1070	182	SEGS5	-2700	1070
117	DUMMY	3150	1070	150	SEG30	180	1070	183	COM24	-2790	1070
118	DUMMY	3060	1070	151	SEG31	90	1070	184	COM23	-2880	1070
119	SEGS1	2970	1070	152	SEG32	0	1070	185	COM22	-2970	1070
120	SEGS2	2880	1070	153	SEG33	-90	1070	186	DUMMY	-3060	1070
121	SEG1	2790	1070	154	SEG34	-180	1070	187	DUMMY	-3150	1070
122	SEG2	2700	1070	155	SEG35	-270	1070	188	DUMMY	-3240	1070
123	SEG3	2610	1070	156	SEG36	-360	1070				

\* NOTE: The COMS1 has two terminals (#101, #110), and these two COMS1 are the same signal at the same time

## PIN DESCRIPTION

### POWER SUPPLY

Table 3. Pin Description

Name	I/O	Description										
VDD	Power	Power supply Connect to MPU power supply pin										
VSS		0V (GND)										
V0 V1 V2 V3 V4	I/O	<p>Bias voltage level for LCD driving            Voltages should have the following relationship;  <math>V0 \geq V1 \geq V2 \geq V3 \geq V4 \geq VSS</math>            When the built-in power circuit is on, the following voltages are given to pins V1 to V4 by internal 1/5 bias resistors are used.</p> <table border="1"> <thead> <tr> <th>LCD bias</th> <th>V1</th> <th>V2</th> <th>V3</th> <th>V4</th> </tr> </thead> <tbody> <tr> <td>(1/5) bias</td> <td>(4/5) x V0</td> <td>(3/5) x V0</td> <td>(2/5) x V0</td> <td>(1/5) x V0</td> </tr> </tbody> </table>	LCD bias	V1	V2	V3	V4	(1/5) bias	(4/5) x V0	(3/5) x V0	(2/5) x V0	(1/5) x V0
LCD bias	V1	V2	V3	V4								
(1/5) bias	(4/5) x V0	(3/5) x V0	(2/5) x V0	(1/5) x V0								

### LCD DRIVER SUPPLY

Table 3. Pin Description (continued)

Name	I/O	Description
CAP1+	O	Capacitor 1+ connecting pin for the internal voltage converter This pin connects the capacitor with CAP1-.
CAP1-	O	Capacitor1- connecting pin for the internal voltage converter This pin connects the capacitor with CAP1+.
CAP2+	O	Capacitor 2+ connecting pin for the internal voltage converter When VOUT is 2 times boosting, this pin connects the capacitor with VDD, when 3 times boosting, this pin connects the capacitor with CAP2-
CAP2-	O	Capacitor2- connecting pin for the internal voltage converter When VOUT is 2 times boosting, this pin is not used, when 3 times boosting, this pin connects the capacitor with CAP2+
VOUT	I/O	2 or 3 times DC/DC voltage converter output This pin connects a capacitor with VDD pin.
VR	I	Voltage adjust pin This pin gives a voltage between V0 and Vss by resistance-division of voltage.

## SYSTEM CONTROL

Table 3. Pin Description (continued)

Name	I/O	Description
CK	I	External clock input pin It must be fixed to "High" when the internal oscillation circuit is used. In the external clock mode, it is used as external clock input pin.
PS	I	Parallel / serial selection pin When PS = "Low": serial mode When PS = "High": 4-bit/8-bit bus mode
IF	I	Interface data length selection pin for parallel data input When PS = "Low" IF = "Low " or "High": serial interface mode When PS = "High" IF = "Low": 4-bit bus mode IF = "High": 8-bit bus mode
BID	I	SEG direction selection pin When BID = "Low"; SEGS1 → SEGS2 → SEG1 → ..... → SEG60 → SEGS4 → SEGS5 When BID = "High"; SEGS5 → SEGS4 → SEG60 → ..... → SEG1 → SEGS2 → SEGS1

## MPU INTERFACE

Table 3. Pin Description (continued)

Name	I/O	Description
RES	I	Initialization is performed by edge sensing of the RES signal. An interface type for the 68/80 series MPU is selected by input level after initialization. When RES = "Low": 68 series MPU When RES = "High": 80 series MPU
CSB	I	Chip selection pin When CSB = "Low": selected When CSB = "High": not selected
RS	I	Register selection pin When RS = "Low": instruction register When RS = "High": data register

Table 3. Pin Description (Continued)

Name	I/O	Description
E	I	In 80 series MPU interface mode, active "Low". This pin connects the $\overline{WR}$ pin of the 80 series MPU. $\overline{WR}$ The signal on the data bus is fetched at the rise of the $\overline{WR}$ signal. In 68 series MPU interface mode, active "High". This pin becomes an enable clock input of the 68 series MPU.
DB0 to DB3 DB4 to DB5 DB6 (SCL) DB7 (SI)	I	When in 8-bit interface mode, DB0 to DB7 are used as input data bus pin In the 4-bit bus mode, only DB4 to DB7 are used as data input pin and DB0 to DB3 are not used. In the serial mode, DB6 (SCL) is used as serial clock input pin, DB7 (SI) is used as serial data input pin and the others are not used.

## LCD DRIVER OUTPUTS (DYNAMIC)

Table 3. Pin Description

Name	I/O	Description
COM1 to COM24	O	Common signal output for character display
COMS1, COMS2	O	Common signal output for icon display The COMS1 has two terminals and these two COMS1 are the same signal at the same time.
SEG1 to SEG60	O	Segment signal output for character display
SEGS1, SEGS2 SEGS4, SEGS5	O	Segment signal output for vertical icon display

## LCD DRIVER OUTPUTS (STATIC)

Table 3. Pin Description (continued)

Name	I/O	Description
COMSA	O	Static common signal output for static icon display
SEGS A, B, C, D, E	O	Static segment signal output for static icon display

\* NOTE: DUMMY - These pins should be opened (floated).

## FUNCTION DESCRIPTION

### SYSTEM INTERFACE

S6A0090 has two kinds of interface type with MPU: bus mode and serial mode. Bus mode or serial mode is selected by PS pin. In bus mode, 4-bit bus or 8-bit bus is selected by IF pin, and 68 series MPU or 80 series MPU is selected by RES pin.

**Table 4. Various kinds of MPU interface according to PS, RES and IF**

PS	RES	IF	CSB	RS	E	DB0 to 3	DB4 to 5	DB6	DB7
Bus mode (H)	80 series (H)	8 bit (H)	CSB	RS	WR	DB0 to 3	DB4 to 5	DB6	DB7
		4 bit (L)	CSB	RS	WR	*	DB4 to 5	DB6	DB7
	68 series (L)	8 bit (H)	CSB	RS	E	DB0 to 3	DB4 to 5	DB6	DB7
		4 bit (L)	CSB	RS	E	*	DB4 to 5	DB6	DB7
Serial mode (L)	(H)/(L)	(H)/(L)	CSB	RS	(H)/(L)	*	*	SCL	SI

"\*": Don't care ("High", "Low" or "Open"), (H)/(L): fixed "High"(VDD) or "Low"(VSS)

PS: "High" = bus mode, "Low" = serial mode

RES: "High" = 80-series MPU, "Low" = 68-series MPU

IF: "High" = 8-bit mode, "Low" = 4-bit mode (PS: "High")

CSB: "High" = chip is not selected, "Low" = chip is selected

RS: "High" = data register, "Low" = instruction register

E: 80-series active "Low", 68-series active "High"

SCL (DB6): serial clock input

SI (DB7): serial data input

#### Interface with MPU in Parallel Mode (PS = "High")

During writing operation, two 8-bit registers, data register (DR) and instruction register (IR), are used. The data register (DR) is used as temporary data storage place for being written into DDRAM / CGRAM / ICONRAM, and one of these RAMs is selected by RAM address setting instruction. The Instruction register (IR) is used only to store instruction code transferred from MPU. To select DR or IR register, RS input pin is used in bus mode or serial mode. In 4-bit bus mode, it is needed to transfer 4-bit data (DB4 to DB7) by two times. The high order bits (for 8-bit mode DB4 to DB7) are transferred before the low order bits (for 8-bit mode DB0 to DB3). The DB0 to DB3 pins are floated in this 4-bit bus mode. After RES resets, S6A0090 considers first 4-bit data from MPU as the high order bits.

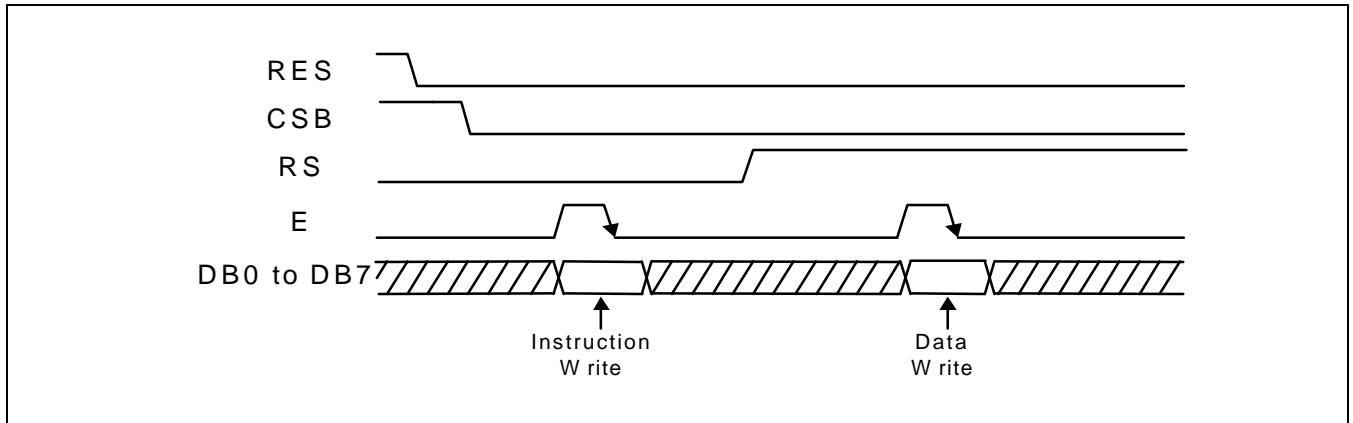

Figure 3. Timing Diagram of 8-bit Parallel Bus Mode Data Transfer (68-series MPU Mode)

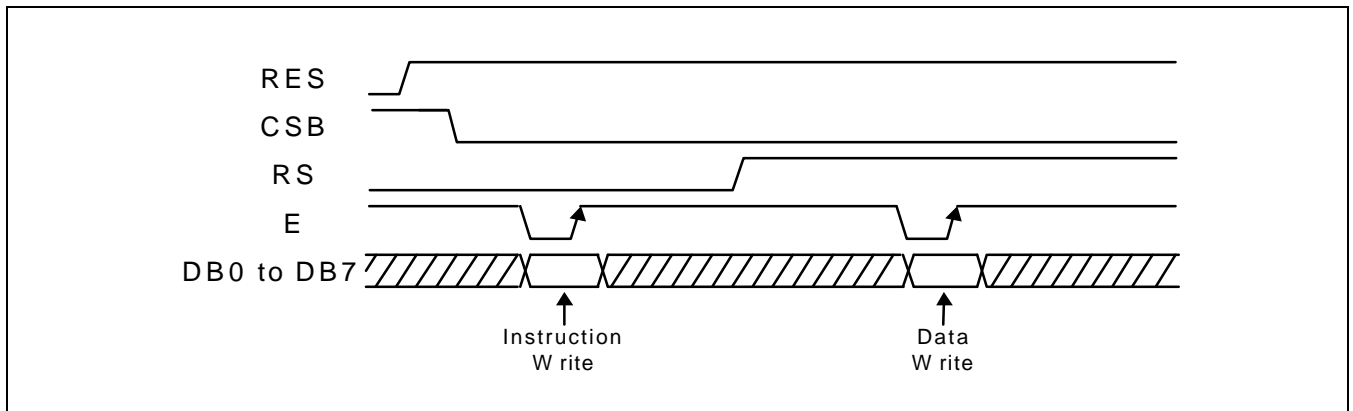

Figure 4. Timing Diagram of 8-bit Parallel Bus Mode Data Transfer (80-series MPU Mode)

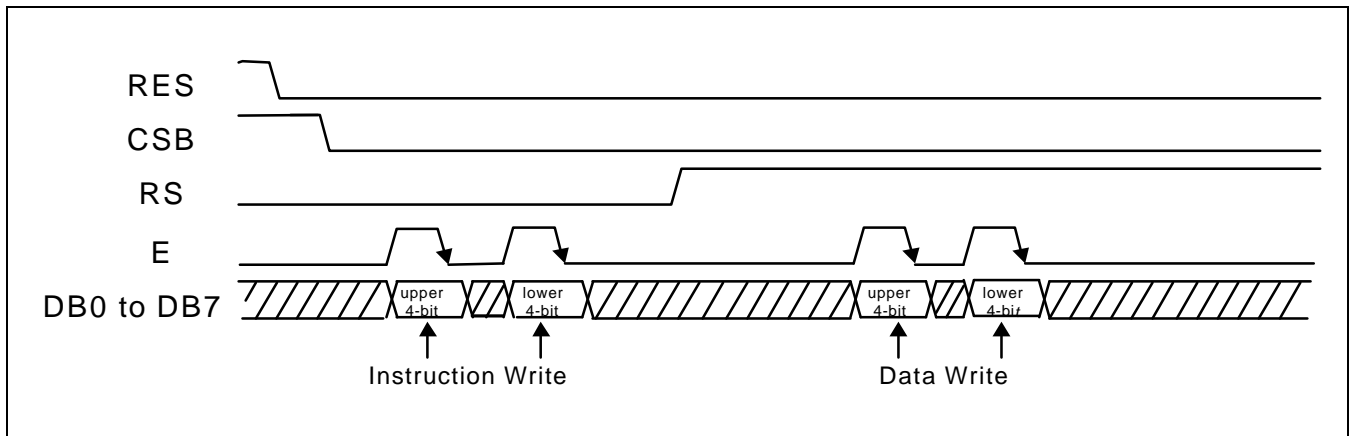

Figure 5. Timing Diagram of 4-bit Parallel Bus Mode Data Transfer (68-series MPU Mode)

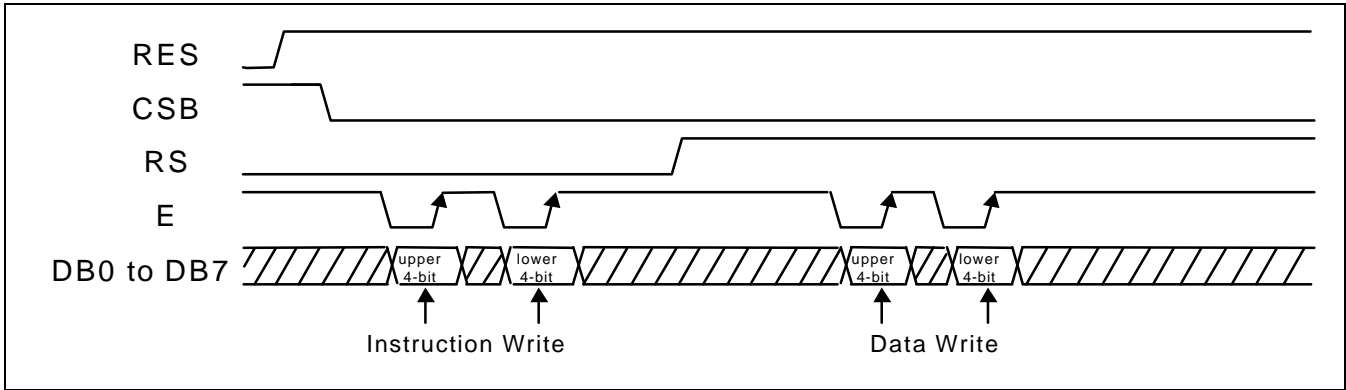

Figure 6. Timing Diagram of 4-bit Parallel Bus Mode Data Transfer (80-series MPU Mode)



### Interface with MPU in Serial Mode (PS = "Low")

When PS input pin is "Low", clock synchronized serial interface mode is selected. At this time, five ports, SCL (DB6, synchronizing transfer clock), SI (DB7, serial input data), RS (register selection input) and CSB (chip selection input) are used. By setting CSB to "Low", S6A0090 can receive SCL input. If CSB is set to "High", S6A0090 resets the internal 8-bit shift register and 3-bit counter. Serial data is input in the order of "D7, D6, D5, D4, D3, D2, D1, D0" from the serial data input pin (SI = DB7) at the rising edge of serial clock (SCL = DB6). At the rising edge of the 8th serial clock, the serial data (D7–D0) is converted into 8-bit bus mode data. The RS input of the DR / IR selection is latched at the rising edge of the 8th serial clock (SCL).

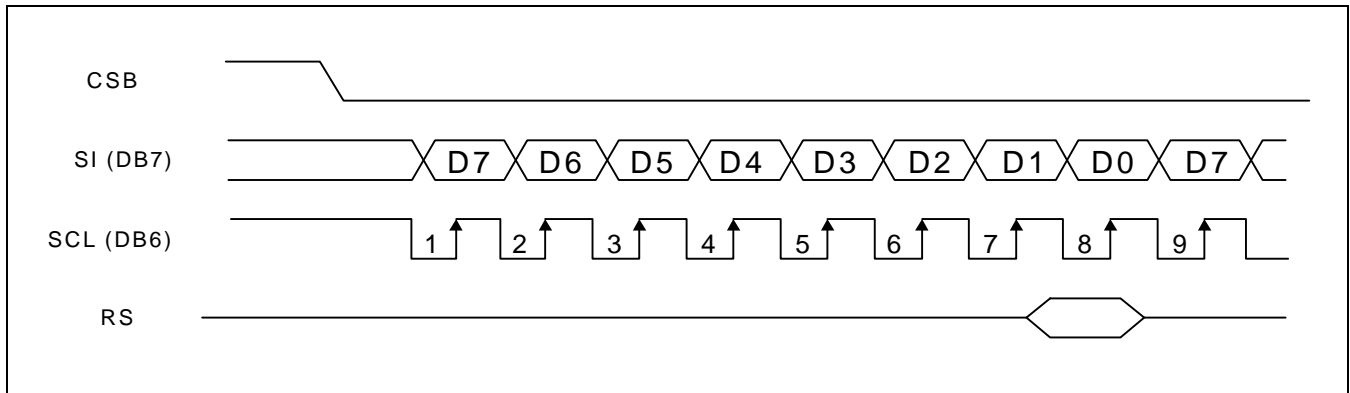

Figure 7. Timing Diagram of Serial Data Transfer

### ADDRESS COUNTER (AC)

Address Counter (AC) in S6A0090 stores CGRAM / DDRAM / ICONRAM address, transferred from IR. After writing into CGRAM / DDRAM / ICONRAM, AC is automatically increased by 1.

### DISPLAY DATA RAM (DDRAM)

DDRAM stores display data of maximum 36 x 8-bits (Max. 36 characters). DDRAM address is set in the address counter (AC) as a hexadecimal number.

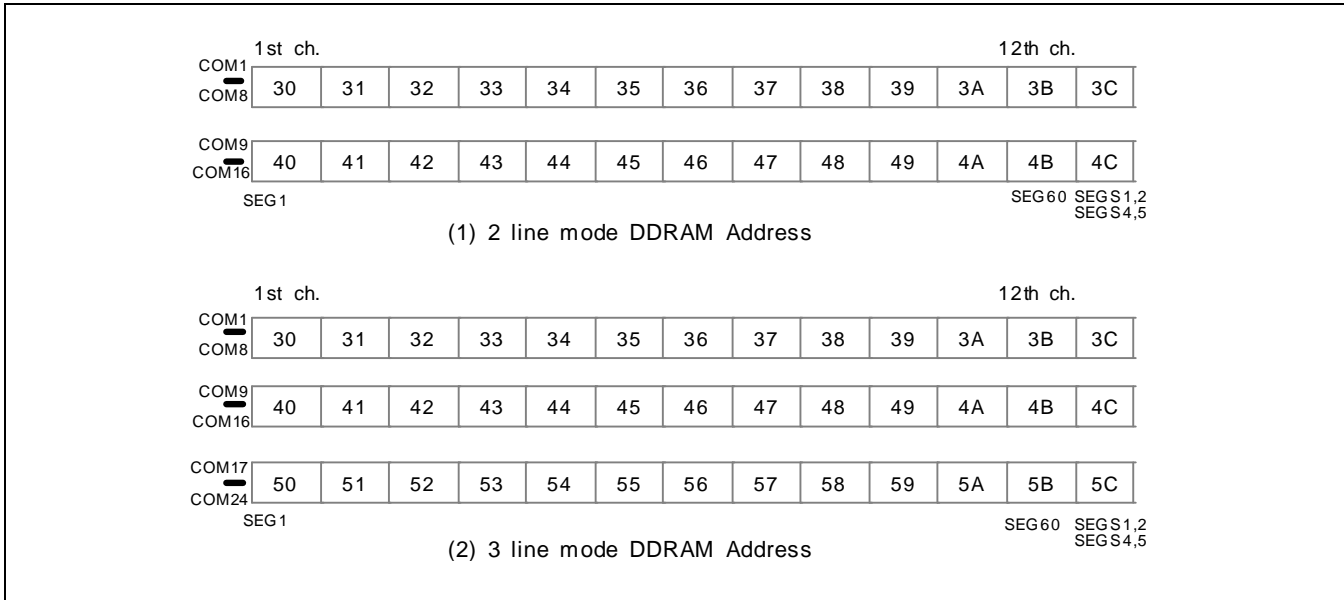

Figure 8. DDRAM Address

### CHARACTER GENERATOR ROM (CGROM)

S6A0090 has the Character Generator ROM (CGROM) consisted of up to 256 types of characters. Character size is 5 x 8 dots. The CG bit of the instruction table selects the 4 characters (00h to 03h) of CGROM or CGRAM. S6A0090 CGROM is contact mask option ROM and compatible with customized ROM font.

Table 5. CGROM Character Code Table (00)

Upper 4bit / Lower 4bit	LLLL	LLLH	LLHL	LLHH	LHLL	LHLH	LHHL	LHHH	HLLL	HLLH	HLHL	HLHH	HHLL	HHLH	HHHL	HHHH
LLLL	[grid]	[grid]	[grid]	[grid]	[grid]	[grid]	[grid]	[grid]	[grid]	[grid]	[grid]	[grid]	[grid]	[grid]	[grid]	[grid]
LLLH	[grid]	[grid]	[grid]	[grid]	[grid]	[grid]	[grid]	[grid]	[grid]	[grid]	[grid]	[grid]	[grid]	[grid]	[grid]	[grid]
LLHL	[grid]	[grid]	[grid]	[grid]	[grid]	[grid]	[grid]	[grid]	[grid]	[grid]	[grid]	[grid]	[grid]	[grid]	[grid]	[grid]
LLHH	[grid]	[grid]	[grid]	[grid]	[grid]	[grid]	[grid]	[grid]	[grid]	[grid]	[grid]	[grid]	[grid]	[grid]	[grid]	[grid]
LHLL	[grid]	[grid]	[grid]	[grid]	[grid]	[grid]	[grid]	[grid]	[grid]	[grid]	[grid]	[grid]	[grid]	[grid]	[grid]	[grid]
LHLH	[grid]	[grid]	[grid]	[grid]	[grid]	[grid]	[grid]	[grid]	[grid]	[grid]	[grid]	[grid]	[grid]	[grid]	[grid]	[grid]
LHHL	[grid]	[grid]	[grid]	[grid]	[grid]	[grid]	[grid]	[grid]	[grid]	[grid]	[grid]	[grid]	[grid]	[grid]	[grid]	[grid]
LHHH	[grid]	[grid]	[grid]	[grid]	[grid]	[grid]	[grid]	[grid]	[grid]	[grid]	[grid]	[grid]	[grid]	[grid]	[grid]	[grid]
HLLL	[grid]	[grid]	[grid]	[grid]	[grid]	[grid]	[grid]	[grid]	[grid]	[grid]	[grid]	[grid]	[grid]	[grid]	[grid]	[grid]
HLLH	[grid]	[grid]	[grid]	[grid]	[grid]	[grid]	[grid]	[grid]	[grid]	[grid]	[grid]	[grid]	[grid]	[grid]	[grid]	[grid]
HLHL	[grid]	[grid]	[grid]	[grid]	[grid]	[grid]	[grid]	[grid]	[grid]	[grid]	[grid]	[grid]	[grid]	[grid]	[grid]	[grid]
HLHH	[grid]	[grid]	[grid]	[grid]	[grid]	[grid]	[grid]	[grid]	[grid]	[grid]	[grid]	[grid]	[grid]	[grid]	[grid]	[grid]
HHLL	[grid]	[grid]	[grid]	[grid]	[grid]	[grid]	[grid]	[grid]	[grid]	[grid]	[grid]	[grid]	[grid]	[grid]	[grid]	[grid]
HHLH	[grid]	[grid]	[grid]	[grid]	[grid]	[grid]	[grid]	[grid]	[grid]	[grid]	[grid]	[grid]	[grid]	[grid]	[grid]	[grid]
HHHL	[grid]	[grid]	[grid]	[grid]	[grid]	[grid]	[grid]	[grid]	[grid]	[grid]	[grid]	[grid]	[grid]	[grid]	[grid]	[grid]
HHHH	[grid]	[grid]	[grid]	[grid]	[grid]	[grid]	[grid]	[grid]	[grid]	[grid]	[grid]	[grid]	[grid]	[grid]	[grid]	[grid]

## CHARACTER GENERATOR RAM (CGRAM)

CGRAM contained in S6A0090 enables user to program of character pattern for display signal. When using CGRAM, the CG bit should be selected to "High". CGRAM has up to four 5 x 8-dot characters. By writing font data to CGRAM, user defined character can be used.

**Table 6. Relationship between Character Code (DDRAM) and Character Pattern (CGRAM)**

Character code (DDRAM data)	CGRAM address	CGRAM data (character pattern)	Pattern number
D7 D6 D5 D4 D3 D2 D1 D0	A6 A5 A4 A3 A2 A1 A0	P7 P6 P5 P4 P3 P2 P1 P0	
0 0 0 0 0 0 0 0 (00h)	0 0 0 0 0 0 0 0 0 0 0 0 0 1 0 0 0 0 0 1 0 0 0 0 0 0 1 1 0 0 0 0 1 0 0 0 0 0 0 1 0 1 0 0 0 0 1 1 0 0 0 0 0 1 1 1	-- -- 0 1 0 1 0 -- -- 1 0 1 0 1 -- -- 0 1 0 1 0 -- -- 1 0 1 0 1 -- -- 0 1 0 1 0 -- -- 1 0 1 0 1 -- -- 0 1 0 1 0 -- -- 1 0 1 0 1	Pattern 1
0 0 0 0 0 0 0 1 (01h)	0 0 0 1 0 0 0 0 0 0 1 0 0 1 0 0 0 1 0 1 0 0 0 0 1 0 1 1 0 0 0 1 1 0 0 0 0 0 1 1 0 1 0 0 0 1 1 1 0 0 0 0 1 1 1 1	-- -- 0 0 0 0 0 -- -- 1 1 1 1 1 -- -- 0 0 0 0 0 -- -- 1 1 1 1 1 -- -- 0 0 0 0 0 -- -- 1 1 1 1 1 -- -- 0 0 0 0 0 -- -- 1 1 1 1 1	Pattern 2
0 0 0 0 0 0 1 0 (02h)	0 0 1 0 0 0 0 0 0 1 0 0 0 1 0 0 1 0 0 1 0 0 0 1 0 0 1 1 0 0 1 0 1 0 0 0 0 1 0 1 0 1 0 0 1 0 1 1 0 0 0 1 0 1 1 1	-- -- 0 1 0 1 0 -- -- 0 1 0 1 0 -- -- 0 1 0 1 0 -- -- 0 1 0 1 0 -- -- 0 1 0 1 0 -- -- 0 1 0 1 0 -- -- 0 1 0 1 0 -- -- 0 1 0 1 0	Pattern 3
0 0 0 0 0 0 1 1 (03h)	0 0 1 1 0 0 0 0 0 1 1 0 0 1 0 0 1 1 0 1 0 0 0 1 1 0 1 1 0 0 1 1 1 0 0 0 0 1 1 1 0 1 0 0 1 1 1 1 0 0 0 1 1 1 1 1	-- -- 0 1 0 1 0 -- -- 0 1 0 1 0 -- -- 1 0 1 0 1 -- -- 1 0 1 0 1 -- -- 0 1 0 1 0 -- -- 0 1 0 1 0 -- -- 1 0 1 0 1 -- -- 1 0 1 0 1	Pattern 4

("-": Don't care)

### SEGMENT ICON RAM (ICONRAM)

ICONRAM has Segment Control Data and Segment Pattern Data

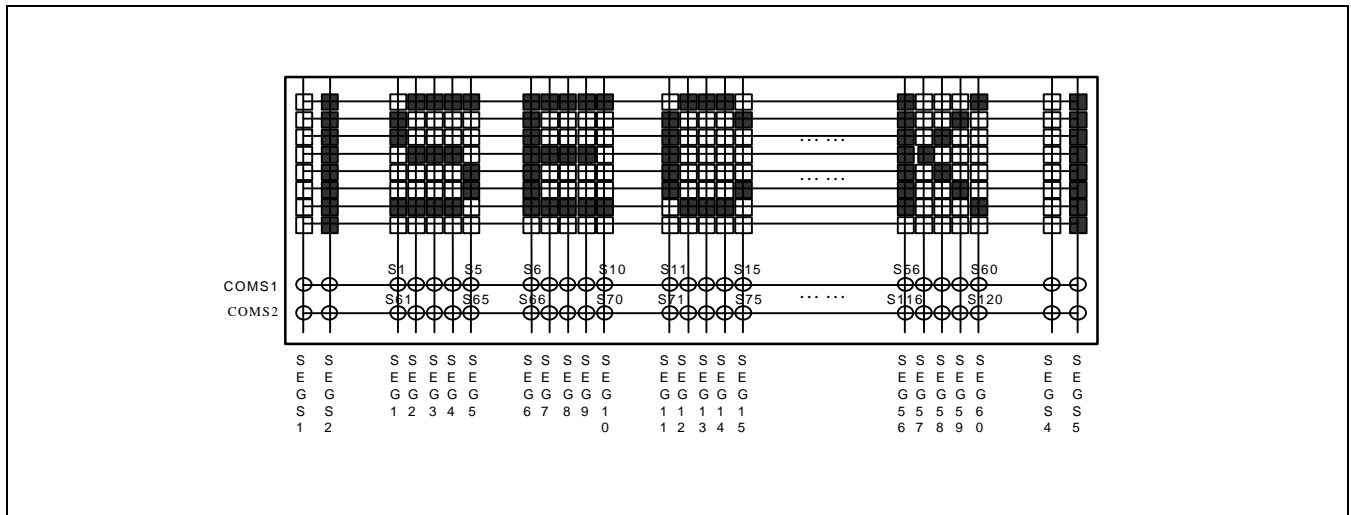

Figure 9. Relationship between ICONRAM and Icon Display

Table 7. Relationship between ICONRAM Address and Display Pattern

ICONRAM address		ICONRAM bits							
High order	Low order	D7	D6	D5	D4	D3	D2	D1	D0
6	0	-	-	-	S1	S2	S3	S4	S5
	1	-	-	-	S6	S7	S8	S9	S10
	:	:	:	:	:	:	:	:	:
	A	-	-	-	S51	S52	S53	S54	S55
	B	-	-	-	S56	S57	S58	S59	S60
	C	-	-	-	SEGS1	SEGS2	-	SEGS4	SEGS5
7	0	-	-	-	S61	S62	S63	S64	S65
	1	-	-	-	S66	S67	S68	S69	S70
	:	:	:	:	:	:	:	:	:
	:	:	:	:	:	:	:	:	:
	A	-	-	-	S111	S112	S113	S114	S115
	B	-	-	-	S116	S117	S118	S119	S120
C	-	-	-	SEGS1	SEGS2	-	SEGS4	SEGS5	

("-": Don't care)

### STATIC ICON RAM (SI)

S6A0090 contains the Static Icon RAM for displaying the static icons in addition to the dynamic icons. Capacity of static icon RAM is 10 bits and is capable of displaying up to 5 icons. The following table shows relationship between the static icon functions, Static Icon RAM address and written data. (blink frequency: 1 to 2 Hz)

**Table 8. Relationship between Static Icon RAM Address and Display Pattern**

Function	RAM address	Static icon data								Static icon				
		D7	D6	D5	D4 (A)	D3 (B)	D2 (C)	D1 (D)	D0 (E)	SEGS-A	B	C	D	E
Display ON / OFF	20h	-	-	-	0	1	0	1	0	<input type="checkbox"/>	<input checked="" type="checkbox"/>	<input type="checkbox"/>	<input checked="" type="checkbox"/>	<input type="checkbox"/>
Blink ON / OFF	21h	-	-	-	1	1	1	0	0	<input checked="" type="checkbox"/>	<input type="checkbox"/>	<input checked="" type="checkbox"/>	<input checked="" type="checkbox"/>	<input type="checkbox"/>

20h = "0": static icon OFF  
 "1": static icon ON

21h = "0": blink OFF  
 "1": blink ON (20h data are inverted)

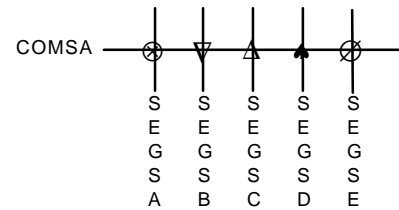

### SEGMENTS FOR SIGNAL DISPLAY (FS)

When DDRAM address is 3Ch: COM1 to COM8, 1-line  
 4Ch: COM9 to COM16, 2-line  
 5Ch: COM17 to COM24, 3-line

SEGS1: font 1st bit display  
 SEGS2: font 2nd bit display  
 SEGS4: font 4th bit display  
 SEGS5: font 5th bit display  
 (Font 3rd bit is not displayed.)

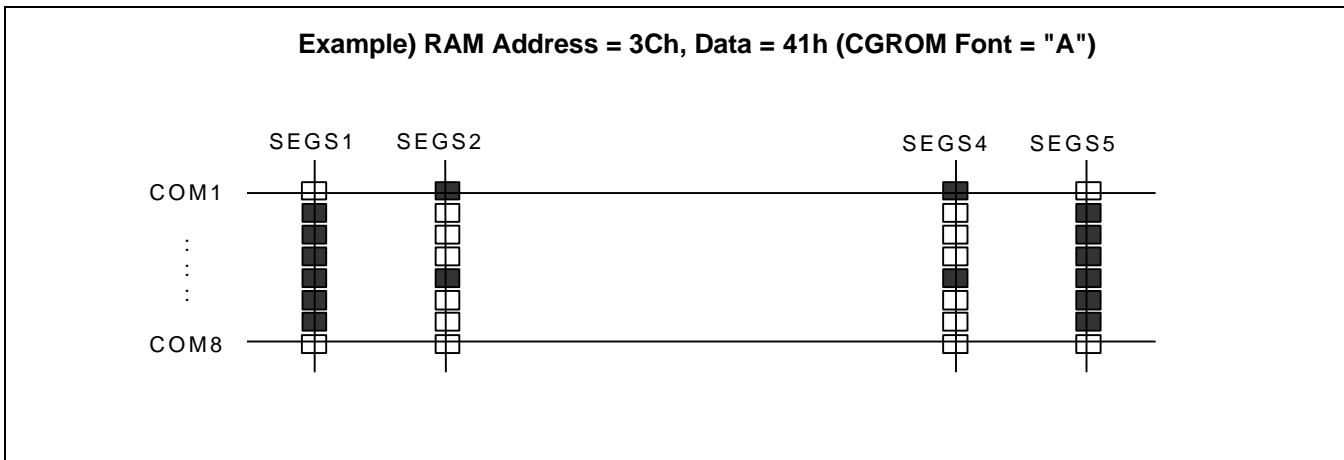
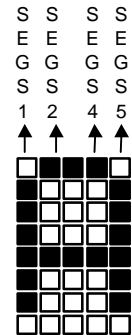

**Figure 10. Segment for Signal Display**

## LOW POWER CONSUMPTION MODE

S6A0090 provides with standby mode and sleep mode for saving power consumption during standby period.

### Standby Mode (Power Save Bit ON, Oscillation Bit ON)

The Standby mode can be switched according to the power save command. In the Standby mode, only static icon is displayed.

1. Liquid Crystal Display Output  
 COM1 to COM24, COMS1, COMS2: V<sub>SS</sub> level  
 SEG1 to SEG60, SEGS1, 2, 4, 5: V<sub>SS</sub> level  
 SEGSA, B, C, D, E, COMSA: V<sub>DD</sub> or V<sub>SS</sub> level (can be turned on/off by static drivers)  
 Use the static icon RAM for controlling the static icon display done with SEGSA, B, C, D, E, COMSA.
2. Written data in DDRAM, CGRAM, ICONRAM and registers remain at its previous value.
3. Operation mode is retained the same as it was prior to execution of the standby mode.  
 The internal circuit for the dynamic display output is stopped.
4. The oscillation circuit for the static display must remain ON.

### Sleep Mode (Power Save ON, Oscillation OFF)

To enter the Sleep Mode, the power circuit and oscillation circuit should be turned off by power save command and power control command. This mode helps to save power consumption by reducing current to reset level.

1. Liquid Crystal Display Output  
 COM1 to COM24, COMS1, COMS2: V<sub>SS</sub> level  
 SEG1 to SEG60, SEGS1, 2, 4, 5: V<sub>SS</sub> level  
 SEGSA, B, C, D, E, COMSA: V<sub>SS</sub> level
2. Written data in DDRAM, CGRAM, ICONRAM and registers remain at its previous value.
3. Operation mode is retained the same as it was prior to execution of the sleep mode.  
 All internal circuits are stopped.
4. Power Circuit and Oscillation Circuit  
 The built-in power supply circuit and oscillation circuit are turned off by power save command and power control command.

## LCD DRIVER CIRCUIT

LCD driver circuit has 26 common and 64 segment signals for driving LCD. Data from ICONRAM / CGRAM / CGROM are transferred to 64-bit segment register serially, and then they are stored to 64-bit latch. For 2-line display mode, COM1 to COM16, COMS1, COMS2 have 1/18 duty, and in 3-line mode, COM1 to COM24, COMS1, COMS2 have 1/26 duty ratio. SEG bi-directional function is selected by BID input pin, and COM shift direction is selected by function set instruction "S" bit.

**Table 9. SEG Data Shift Direction**

BID pin	SEG data shift direction
Low	SEGS1 → SEGS2 → SEG1 → ..... → SEG60 → SEGS4 → SEGS5
High	SEGS5 → SEGS4 → SEG60 → ..... → SEG1 → SEGS2 → SEGS1

## INSTRUCTION DESCRIPTION

Table 10. Instruction Table

Instruction	Instruction code									Description
	RS	DB7	DB6	DB5	DB4	DB3	DB2	DB1	DB0	
Return home	0	0	0	0	1	-	-	-	-	DDRAM address is set to "30h" from AC and cursor returns to "30h" position if shifted. The contents of DDRAM are not changed.
Display control	0	0	0	1	1	C	B	-	D	Cursor / blink / display ON / OFF C = 0: cursor OFF (default), C = 1: cursor ON B = 0: blink OFF (default), B = 1: blink ON D = 0: display OFF (default), D = 1: display ON
Power save	0	0	1	0	0	-	-	OS	PS	Power save / oscillation circuit OS=0: oscillator OFF (default), OS=1: oscillator ON PS=0: power save OFF (default), PS=1: power save ON
Power control	0	0	1	0	1	0	VR	VF	VC	LCD power control VR = 0: voltage regulator OFF (default), 1: voltage regulator ON VF = 0 : voltage follower OFF (default), 1: voltage follower ON VC = 0: voltage converter OFF (default), 1: voltage converter ON
Function set	0	0	1	1	0	N2	N1	S	CG	Display line mode N2, N1 = 0, 0: 2-line display mode (default), 0, 1: 3-line display mode Set shifting direction of COM S = 0: COM left shift (COM1 → COM24) (default), 1: COM right shift (COM24 → COM1) Select CGRAM or CGROM CG = 0: use CGROM (default), 1: use CGRAM
RAM address set	0	1	AC6	AC5	AC4	AC3	AC2	AC1	AC0	DDRAM / CGRAM / ICONRAM or register address
Write data	1	D7	D6	D5	D4	D3	D2	D1	D0	Write DDRAM / CGRAM / ICONRAM or register data
EV mode	0	0	0	0	0	0	0	0	EV	Electronic volume step EV = 0: 32 contrast-step (default), 1: 64 contrast-step
Test mode	0	0	0	0	0	*	*	*	*	Instruction for IC chip test Don't use this instruction.

("-": Don't care, "\*\*\*": Don't use)

\* NOTE1: For the NOP instruction,

when EV mode is "0" (32 contrast-step), the NOP instruction set is (00000000),

when EV mode is "1" (64 contrast-step), the NOP instruction set is (00000001).

\* NOTE2: Instruction execution time depends on the internal process time of S6A0090, therefore it is necessary to provide a time larger than one MPU interface cycle time (tc) between execution of two successive instructions.



### Return Home

Return Home instruction field makes cursor return home. DDRAM address is set to "30h" into the address counter. Return cursor to first digit of the first line. Contents of DDRAM are not changed.

RS	DB7	DB6	DB5	DB4	DB3	DB2	DB1	DB0
0	0	0	0	1	-	-	-	-

("-": Don't care)

### Display Control

Display Control instruction field controls cursor / blink / display ON / OFF.

RS	DB7	DB6	DB5	DB4	DB3	DB2	DB1	DB0
0	0	0	1	1	C	B	-	D

("-": Don't care)

C: Cursor ON / OFF control bit

When C = "High", cursor is turned ON.

When C = "Low", cursor is disappeared in current display, and can't blink (default).

B: Cursor blink ON / OFF control bit

When C = "High" and B = "High", S6A0090 makes LCD alternate between inverting display character and normal display character at the cursor position with about a half second. On the contrary, if

C = "Low", only a normal character is displayed regardless of "B" flag.

When B = "Low", blink is OFF (default).

D: Display ON / OFF control bit

When D = "High", entire display is turned ON

When D = "Low", display is turned OFF, but display data remain in DDRAM (default).

\* NOTE: Static icons driven by COMSA and SEGSA / B / C / D / E must be controlled by the static icon RAM.

### Power Save

Power Save instruction field is used to control the oscillator and to control Power Save mode.

RS	DB7	DB6	DB5	DB4	DB3	DB2	DB1	DB0
0	0	1	0	0	–	–	OS	PS

("–": Don't care)

OS: Oscillator ON / OFF control bit

When OS = "High", oscillator circuit is turned ON.

When OS = "Low", oscillator is turned OFF (default).

PS: Power save ON / OFF control bit

When PS = "High", power save mode is turned ON.

When PS = "Low", power save mode is turned OFF (default).

### Power Control

Power Control instruction field sets voltage regulator / follower / converter ON / OFF.

RS	DB7	DB6	DB5	DB4	DB3	DB2	DB1	DB0
0	0	1	0	1	0	VR	VF	VC

VR: Voltage regulator circuit control bit

When VR = "High", voltage regulator is turned ON.

When VR = "Low", voltage regulator is turned OFF (default).

VF: Voltage follower circuit control bit

When VF = "High", voltage follower is turned ON.

When VF = "Low", voltage follower is turned OFF (default).

VC: Voltage converter circuit control bit

When VC = "High", voltage converter is turned ON.

When VC = "Low", voltage converter is turned OFF (default).

\* NOTE: The oscillator circuit must be turned on for the voltage converter circuit to be active.

**Function Set**

RS	DB7	DB6	DB5	DB4	DB3	DB2	DB1	DB0
0	0	1	1	0	N2	N1	S	CG

N2, N1: Display line mode instruction field select 2-line or 3-line display mode.

When N2, N1 = "Low, Low", 2-line display mode (default)

When N2, N1 = "Low, High", 3-line display mode

S: Data shift direction of common.

When S = "High", COM right shift (default)

When S = "Low", COM left shift

Line mode	S	COM data shift direction
2-line mode	0 (left)	COM1 → ..... → COM15 → COM16 → COMS1 → COMS2 → COM1
	1 (right)	COM16 → COM15 → ..... → COM1 → COMS1 → COMS2 → COM16
3-line mode	0 (left)	COM1 → ..... → COM23 → COM24 → COMS1 → COMS2 → COM1
	1 (right)	COM24 → COM23 → ..... → COM1 → COMS1 → COMS2 → COM24

CG: CGRAM enable bit

When CG = "High", CGRAM can be accessed and you can use this RAM as a four special character area. (00h to 03h = CGRAM font display).

When CG = "Low", CGRAM is disabled. CGROM (00h to 03h) can be accessed and additional current consumption is saved by using this mode (default), (00h to 03h = CGROM font display).

**RAM Address Set**

RAM Address set instruction field sets CGRAM / DDRAM / ICONRAM or register address. Each RAM is distinguished by a RAM address. Before writing data into the RAM, set the address by RAM address set instruction. Next, when data are written in succession, the address is automatically increased by 1.

RS	DB7	DB6	DB5	DB4	DB3	DB2	DB1	DB0
0	1	AC6	AC5	AC4	AC3	AC2	AC1	AC0

Address	0	1	2	3	4	5	6	7	8	9	A	B	C	D	E	F
00h	CGRAM (00h)							CGRAM (01h)								
10h	CGRAM (02h)							CGRAM (03h)								
20h	SI	Unused						EV	TE	Unused						
30h	DD RAM 1-line (30h to 3Bh)											FS	Unused			
40h	DD RAM 2-line (40h to 4Bh)											FS				
50h	DD RAM 3-line (50h to 5Bh)											FS				
60h	ICONRAM COMS1 icon (60h to 6Ch)													Unused		
70h	ICONRAM COMS2 icon (70h to 7Ch)															

SI: static icon register (20h, 21h)

It is used for SEGS / B / C / D / E.

EV: electronic volume register (28h)

TE: test register (29h) (Do not use)

FS: for signals - 1-line (3Ch), 2-line (4Ch), 3-line (5Ch).

It is used for SEGS1 / 2 / 4 / 5

**Write Data**

This instruction field makes S6A0090 write binary 8-bit data to DDRAM/CGRAM/ICONRAM or register. The RAM address to be written into is determined by the previous RAM Address Set Instruction. After writing operation, the address is automatically increased by 1.

RS	DB7	DB6	DB5	DB4	DB3	DB2	DB1	DB0
1	D7	D6	D5	D4	D3	D2	D1	D0

**EV Mode**

This instruction field selects between 2 electronic volume steps: 32 and 64 contrast-steps.

RS	DB7	DB6	DB5	DB4	DB3	DB2	DB1	DB0
0	0	0	0	0	0	0	0	EV

When EV = "Low", S6A0090 selects 32 contrast-step (default)

Electronic volume register (28h) =

DB7	DB6	DB5	DB4	DB3	DB2	DB1	DB0
-	-	-	C4	C3	C2	C1	C0

("-": Don't care)

When EV = "High", S6A0090 selects 64 contrast-step.

Electronic volume register (28h) =

DB7	DB6	DB5	DB4	DB3	DB2	DB1	DB0
-	-	C5	C4	C3	C2	C1	C0

("-": Don't care)

## INITIALIZING & POWER SAVE MODE SETUP

### HARDWARE RESET

After reset by RES pin, S6A0090 can be initialized the following state.

#### Control Display ON / OFF Instruction

- C = 0: cursor OFF
- B = 0: blink OFF
- D = 0: display OFF

#### Power Save Set Instruction

- OS = 0: oscillator OFF
- PS = 0: power save OFF

#### Power Control Set Instruction

- VR = 0: voltage regulator OFF
- VF = 0: voltage follower OFF
- VC = 0: voltage converter OFF

#### Function Set Instruction

- N2 = 0, N1 = 0: 2-line display mode
- S = 0: COM left shift
- CG = 0: CGRAM is not used.

#### Return Home

Address counter = 30h

#### Static icon RAM & Electronic Contrast Control Register

Static icon RAM: 20h = (0, 0, 0, 0, 0), static icon OFF  
 21h = (0, 0, 0, 0, 0), blink OFF

EV = 0: 32 contrast-step

Electronic contrast control register: 28h = ((0), 0, 0, 0, 0, 0), contrast high

**In Case of 4-bit Interface Mode, S6A0090 considers the First 4-bit Data from MPU as the High Order Bits.**

\*NOTE: If initialization is not done by the RES pin at application, an unknown condition may result. Then you can initialize by instruction.

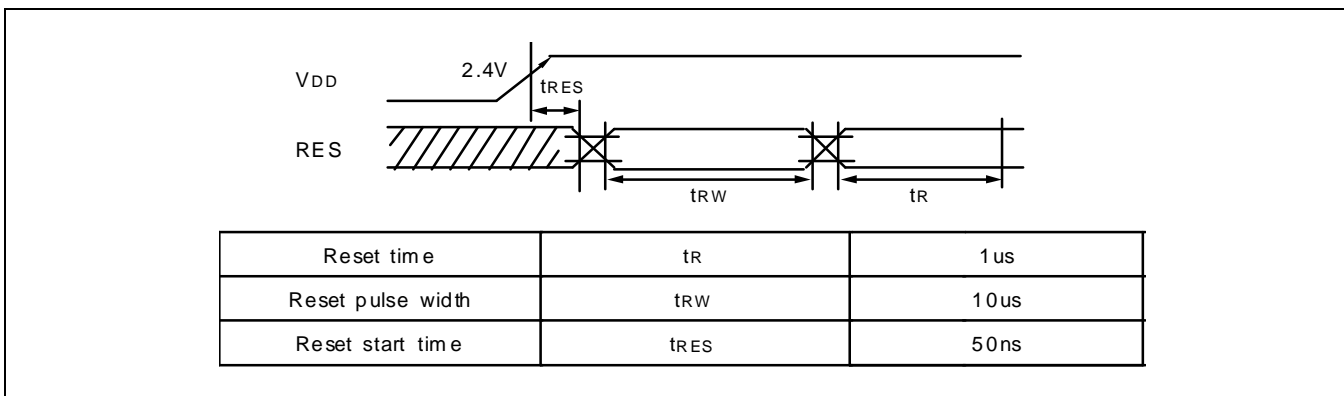

**Figure 11. Reset Timing**

\* NOTE: t<sub>R</sub> (reset time) indicates the internal circuit reset completion time from the edge of the RES signal Accordingly, the S6A0090 usually enters the operating state after t<sub>R</sub>.

Specifies the minimum pulse width of the RES signal. It is reset when a signal having the pulse width greater than t<sub>RW</sub> is entered.

## INITIALIZING AND POWER SAVE MODE SETUP

### Initializing by Instruction

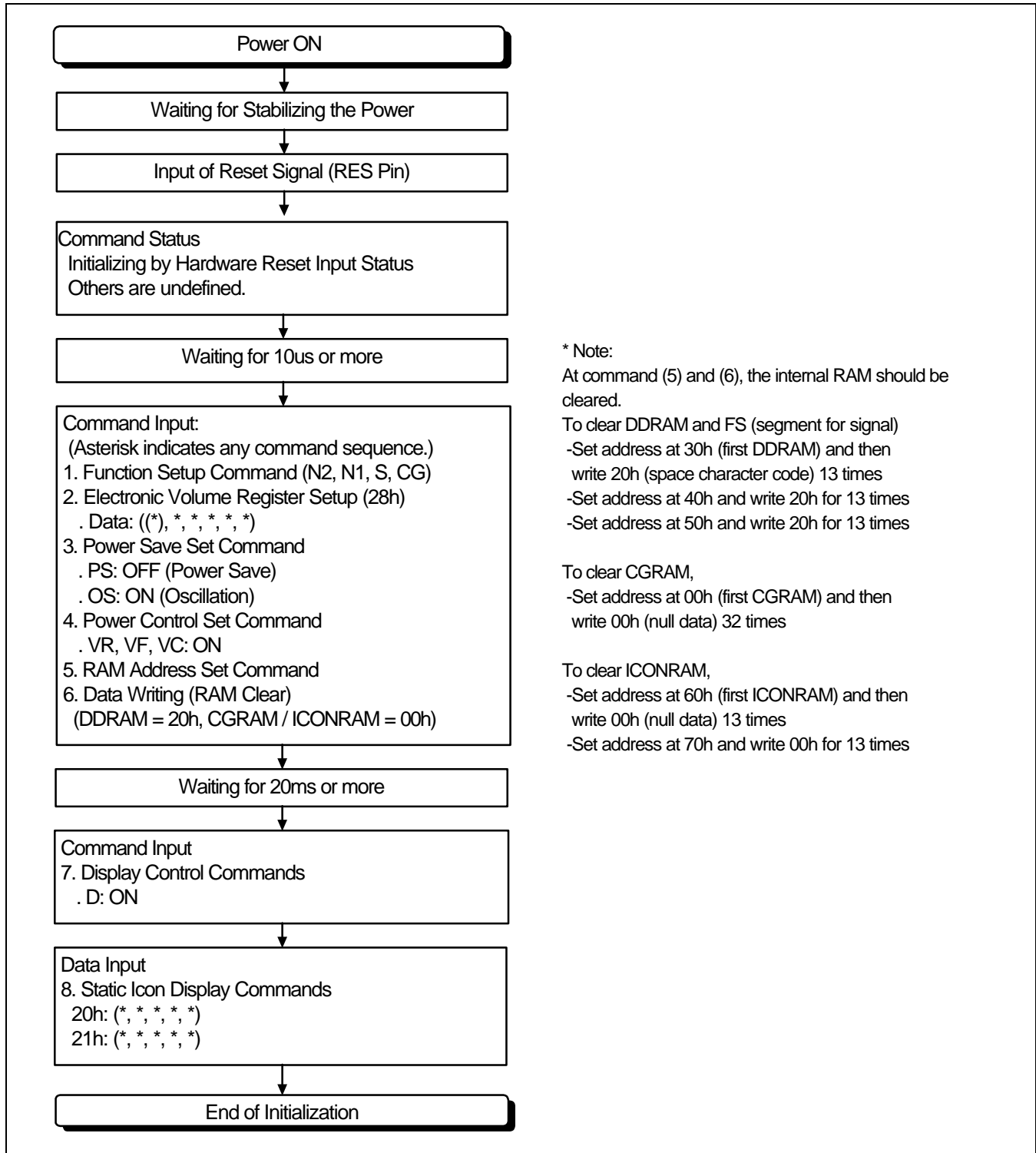
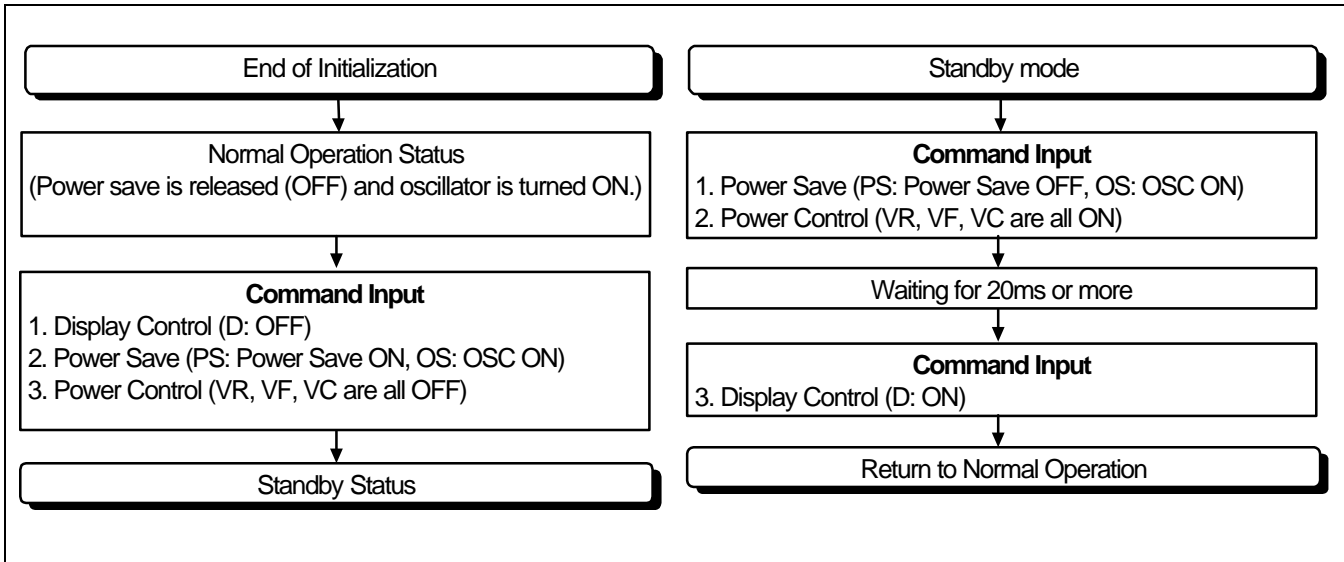

Figure 12. Initializing by Instruction

**Standby Mode Set or Release by Instruction**



**Figure 13. Standby Mode Set**

**Figure 14. Standby Mode Release**

**Sleep Mode Set or Release by Instruction**

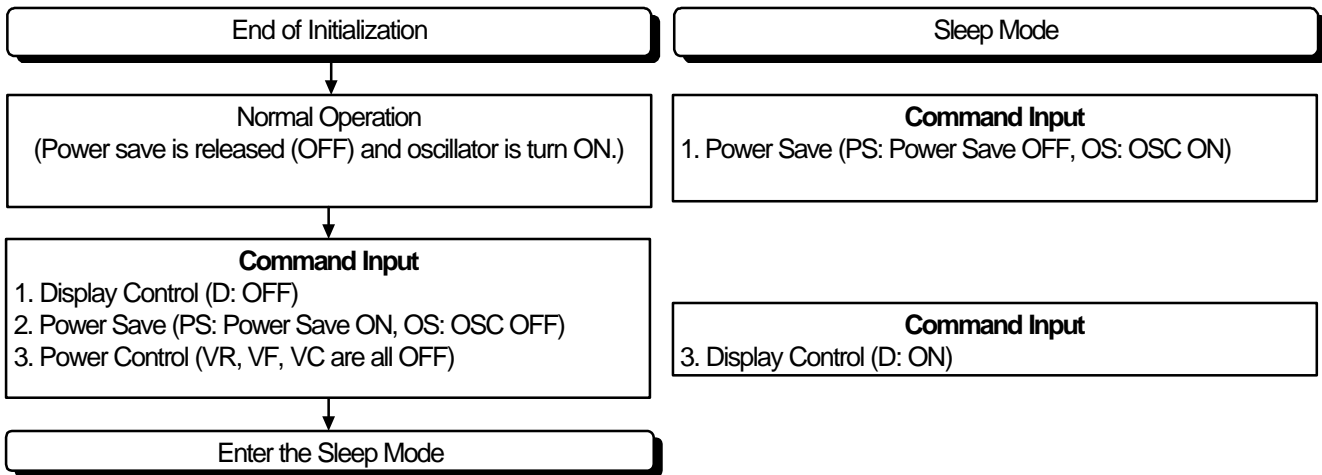



### Recommendation of Power ON / OFF Sequence

#### a) Power ON Sequence

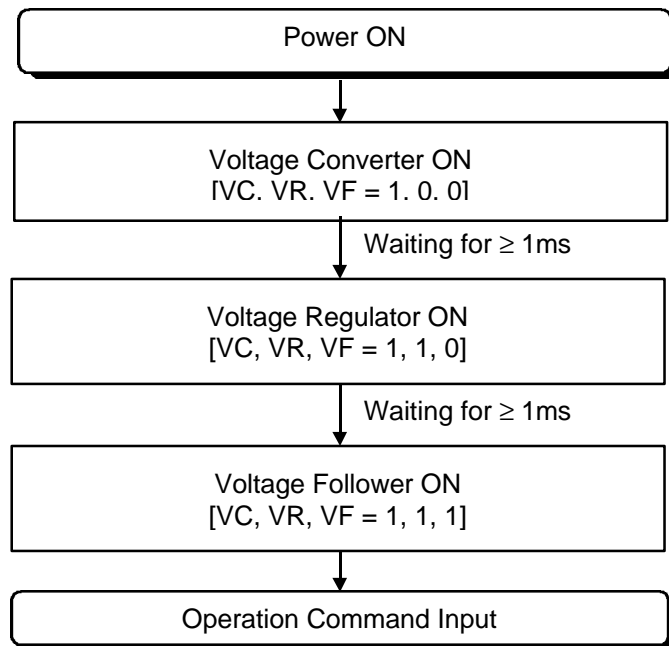

#### b) Power OFF Sequence

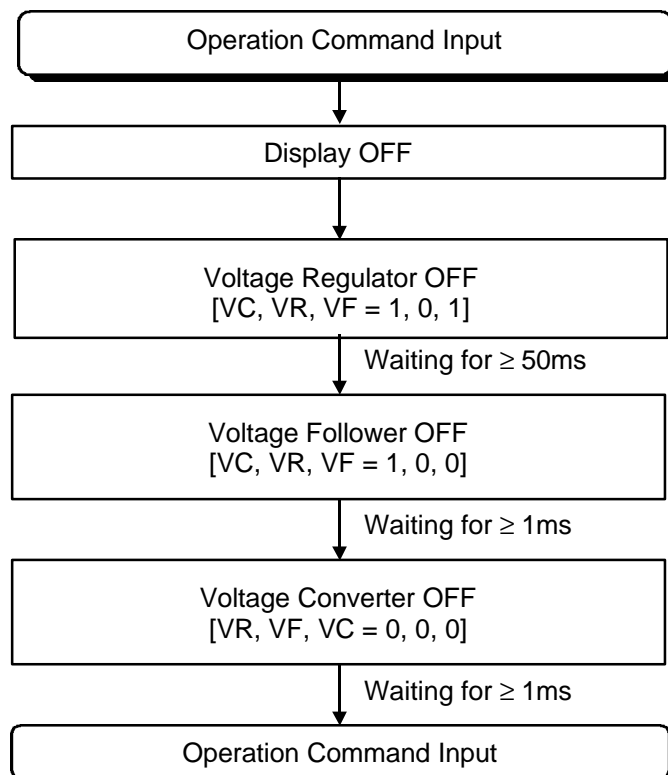

## LCD DRIVING POWER SUPPLY CIRCUIT

The Power Supply Circuit produces LCD panel driving voltage at low power consumption. The LCD driving power supply circuit consists of voltage converter (2 times or 3 times), voltage regulator and voltage follower. It is controlled by set power control instruction. The following table shows how the LCD driving power supply circuit works by power control instruction sets.

**Table 11. Power Supply Control Mode Set**

VC VR VF	Voltage converter	Voltage regulator	Voltage follower	VOUT pin	VR pin	V0, V1, V2, V3, V4 pin
1 1 1	Enable	Enable	Enable	Internal voltage output	Used for voltage adjustment	Internal voltage output
0 1 1	Disable	Enable	Enable	External voltage input	Used for voltage adjustment	Internal voltage output
0 0 1	Disable	Disable	Enable	Open	Open	V1 to V4: internal voltage output V0: external voltage input
0 0 0	Disable	Disable	Disable	Open	Open	V0 to V4: external voltage input

\* NOTE: SEC recommendation is to use only the case listed above table.

### VOLTAGE CONVERTER

If capacitors are connected between CAP1+ and CAP1-, CAP2+ and CAP2-, VDD and VOUT, VDD- VSS voltage is positively tripled and generated at VOUT terminal. When the voltage is doubled, open CAP2- and connect CAP2+ to VOUT terminal. This boosted voltage is used in the built-in voltage regulator circuit.

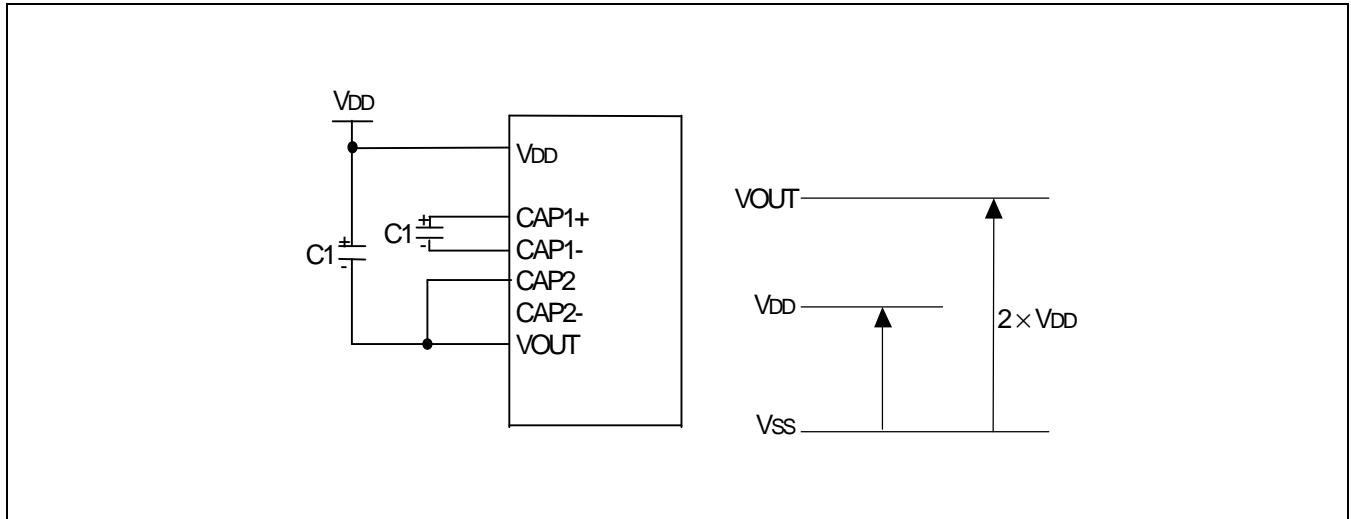

Figure 17. Two Times Boosting

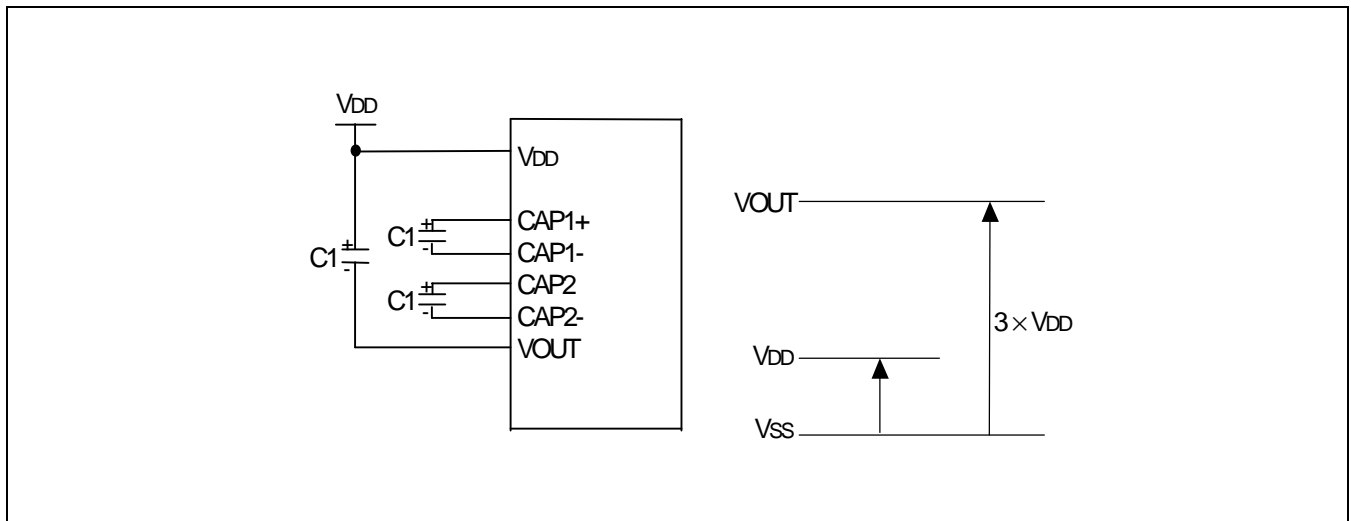

Figure 18. Three Times Boosting

### VOLTAGE REGULATOR

The Voltage Regulator circuit is used to obtain an appropriate LCD panel driving voltage. This voltage is obtained by adjusting resistors Ra and Rb as shown in equation (1), and by setting electronic contrast control data bits, see equation (1), (2)

The potential of V0 pin can be adjusted within VREF to VOUT. VREF is the internal constant voltage source of the chip and this value is 2.0V in the condition VDD ≥ 2.4V

Voltage regulation by adjusting resistors Ra, Rb

$$V0 = \left( 1 + \frac{Rb}{Ra} \right) \times VREF \quad \text{----- (1)}$$

The internal VREF of the voltage regulator has the temperature compensation function, and the temperature coefficient is approximately -0.05%/°C.

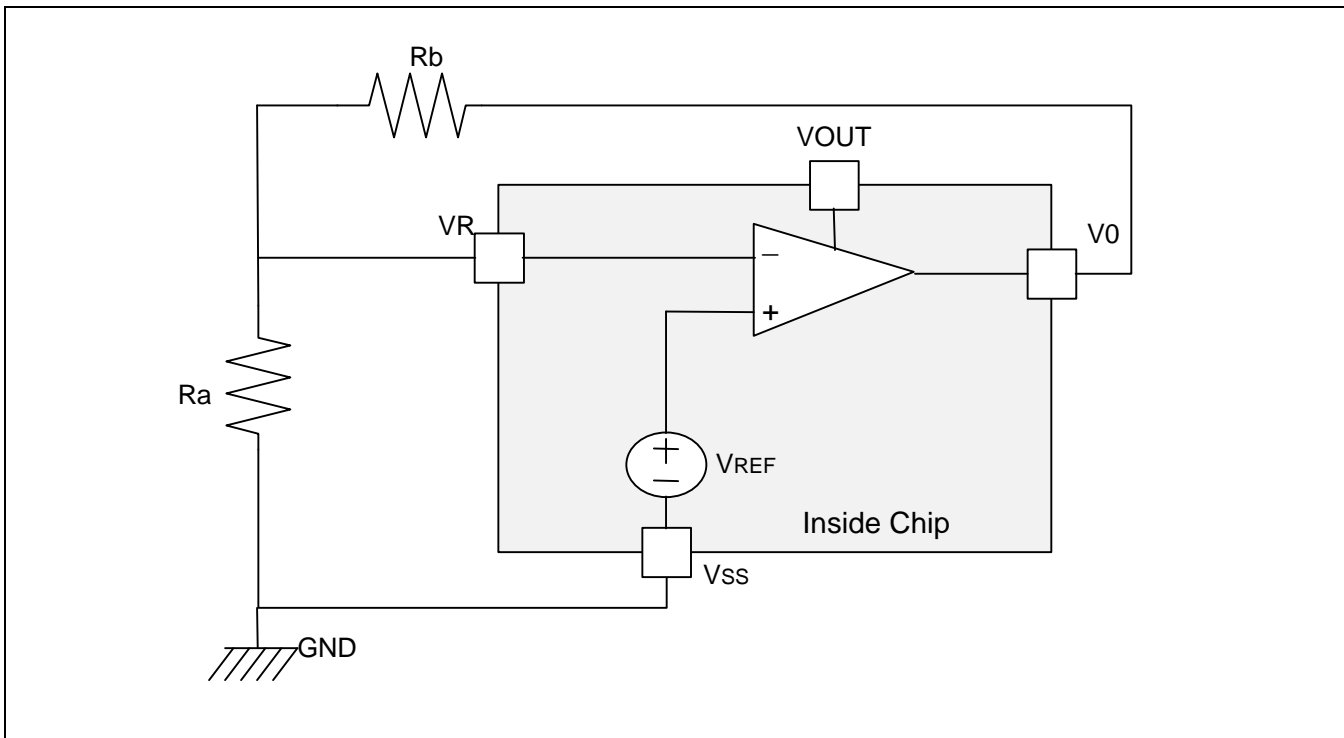

Figure 19. Voltage Regulator Circuit

**Electronic Contrast Control (EV = 0, 32 Steps)**

For 32 contrast-step, EV flag of EV set mode instruction field should be set to "Low", and then, Electronic Contrast Control data bits 28h = (C4, C3, C2, C1, C0) can be valid. Voltage regulation is adjusted as 32-contrast step according to the value of electronic contrast control data bits. LCD drive voltage V0 has one of 32 voltage values if 5-bit data is set to the Electronic Contrast Control register (RAM address 28h).

When using the Electronic Contrast Control function, you need to turn the voltage regulator on using power control instruction.

$$V0 = \left( 1 + \frac{Rb}{Ra} \right) \times VEV \quad \text{----- (2)}$$

$$VEV = VREF - n\alpha \quad (n = 0, 1, 2, \dots, 30, 31)$$

$$\alpha = VREF / 150$$

For example,  
 Ra = 1 [MΩ], Rb = 2 [MΩ], n = 0  
 then V0 = 6V

**Table 12. Electronic Contrast Control Register (32 steps)**

No.	C7	C6	C5	C4	C3	C2	C1	C0	nα	V0	Contrast
1	-	-	-	0	0	0	0	0	0α (default)	Maximum	High
2	-	-	-	0	0	0	0	1	1α	.	.
3	-	-	-	0	0	0	1	0	2α	.	.
4	-	-	-	0	0	0	1	1	3α	.	.
.	.	.	.	.	.	.	.	.	.	.	.
.	.	.	.	.	.	.	.	.	.	.	.
.	.	.	.	.	.	.	.	.	.	.	.
31	-	-	-	1	1	1	1	0	30 α	.	.
32	-	-	-	1	1	1	1	1	31 α	Minimum	Low

("-": Don't care)

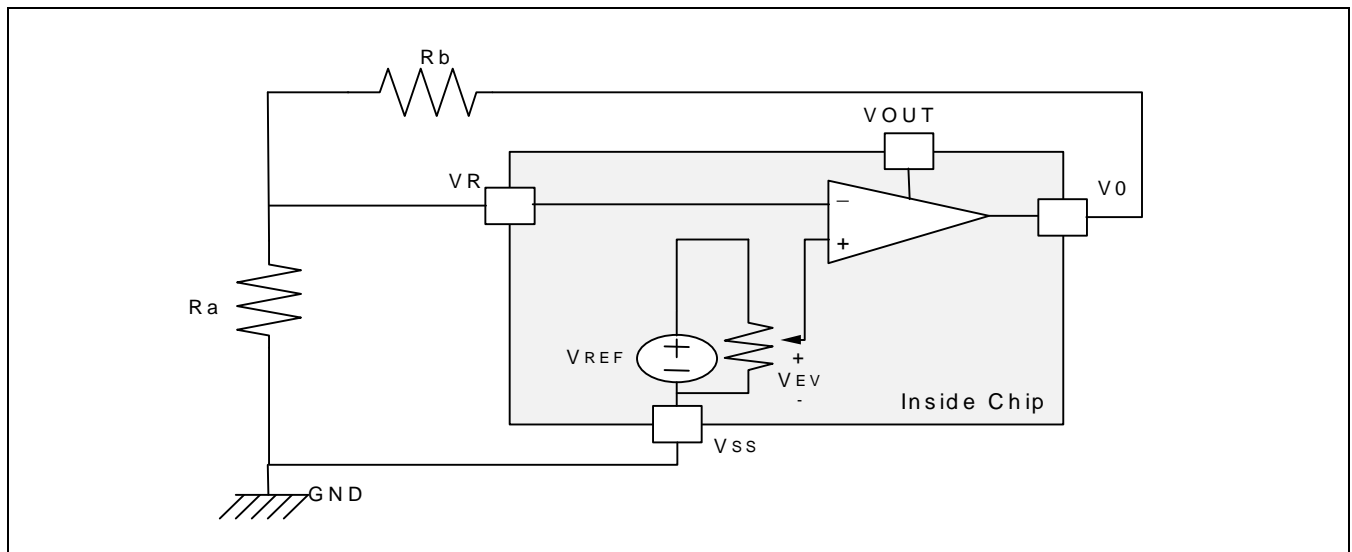

**Figure 20. Electronic Contrast Control Circuit**

**Electronic Contrast Control (EV=1, 64 Steps)**

For 64 contrast-step, EV flag of EV set mode instruction field should be set to "High", after this, Electronic Contrast Control data bits 28h = (C5, C4, C3, C2, C1, C0) can be valid. Voltage regulation is adjusted as 64-contrast step according to the value of Electronic Contrast Control data bits. LCD drive voltage V0 has one of 64 voltage values if 6-bit data is set to the Electronic Contrast Control register (RAM address 28h). When using the Electronic Contrast Control function, you need to turn the voltage regulators on using power control instruction.

$$V0 = \left( 1 + \frac{Rb}{Ra} \right) \times VEV \quad \text{----- (3)}$$

$$VEV = VREF - n\alpha \quad (n = 0, 1, 2, \dots, 62, 63)$$

$$\alpha = VREF / 300$$

**Table 13. Electronic Contrast Control Register (64 Steps)**

No.	C7	C6	C5	C4	C3	C2	C1	C0	nα	V0	Contrast
1	-	-	0	0	0	0	0	0	0α (default)	Maximum	High
2	-	-	0	0	0	0	0	1	1α	.	.
3	-	-	0	0	0	0	1	0	2α	.	.
4	-	-	0	0	0	0	1	1	3α	.	.
.	.	.	.	.	.	.	.	.	.	.	.
.	.	.	.	.	.	.	.	.	.	.	.
.	.	.	.	.	.	.	.	.	.	.	.
62	-	-	1	1	1	1	1	0	62 α	.	.
63	-	-	1	1	1	1	1	1	63 α	Minimum	Low

("-": Don't care)

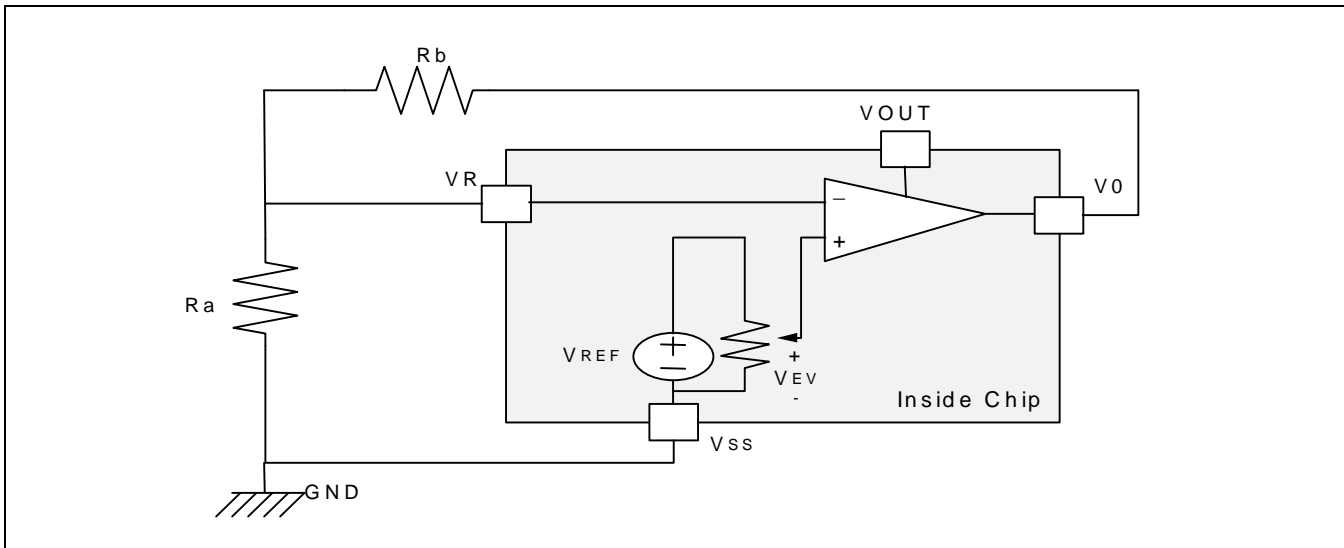

**Figure 21. Electronic Contrast Control Circuit**

VOLTAGE GENERATOR CIRCUIT

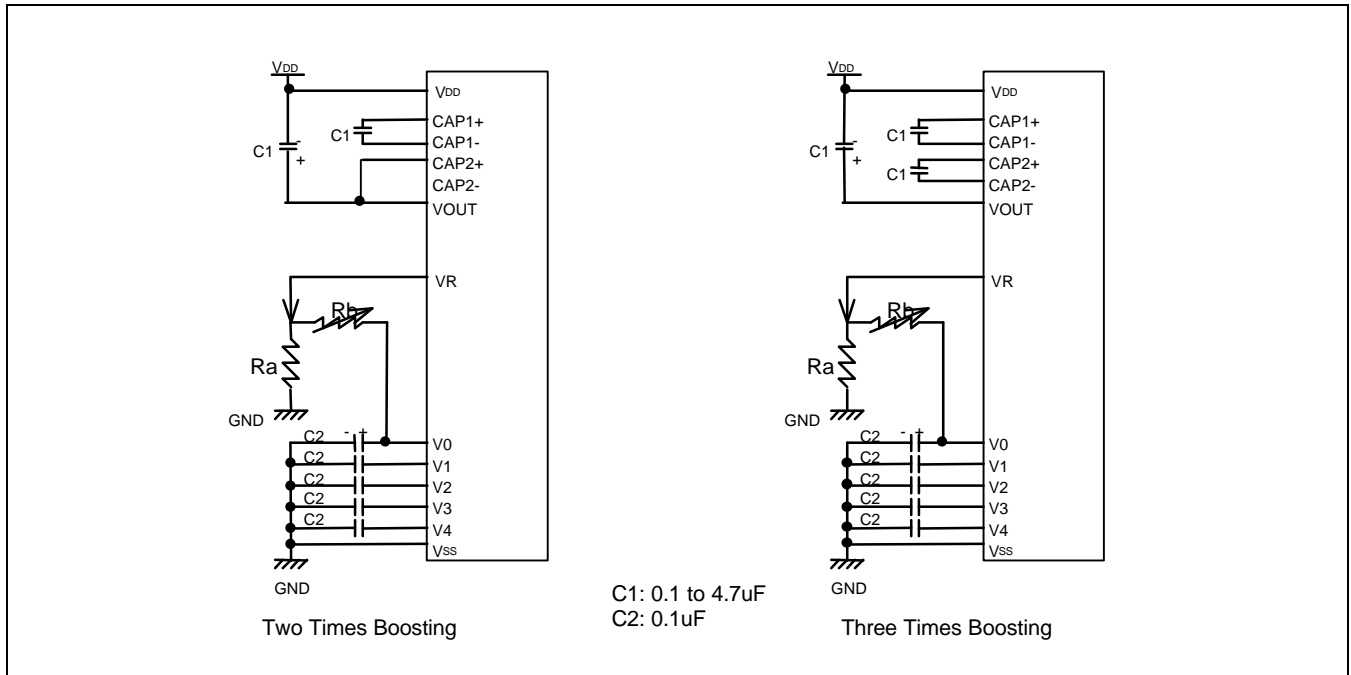

Figure 22. When Built-in Power Supply is used (VC, VR, VF = 1, 1, 1)

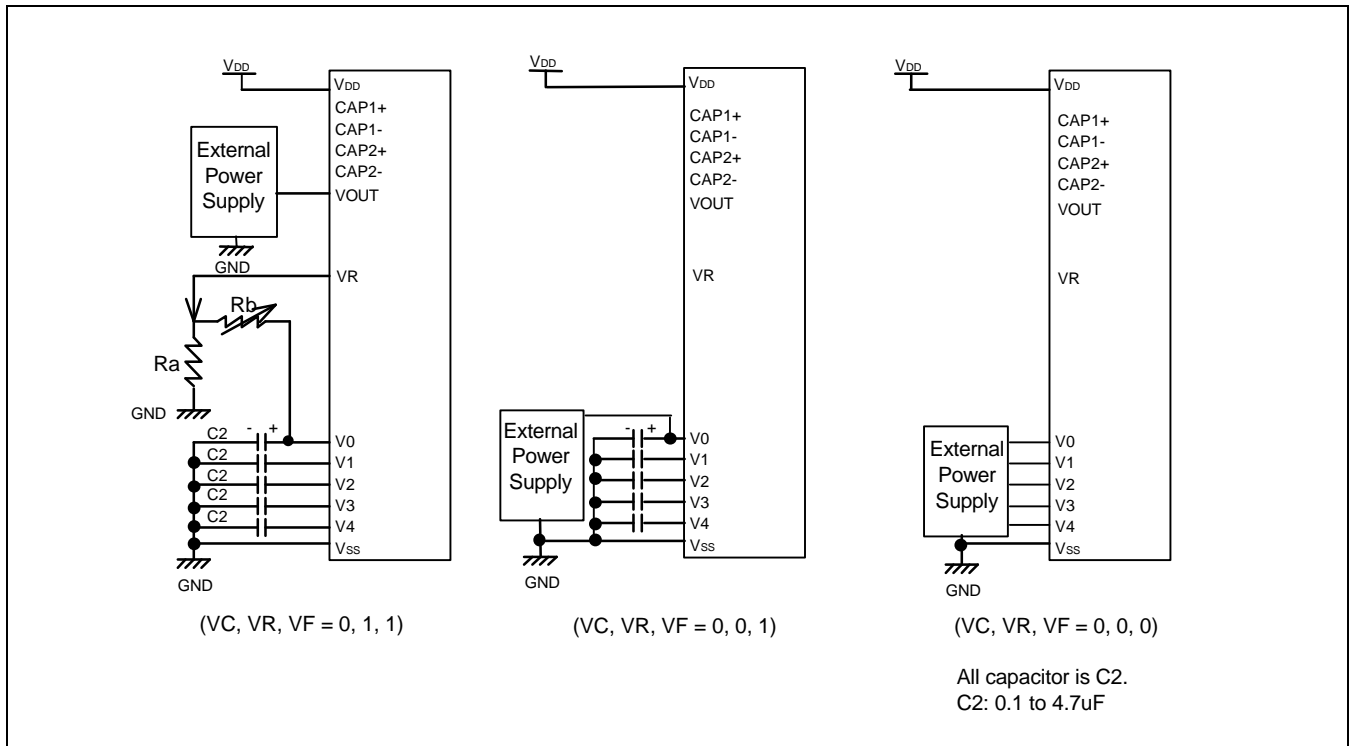

Figure 23. When External Power Supply is used

## REFERENCE APPLICATIONS

### MPU INTERFACE

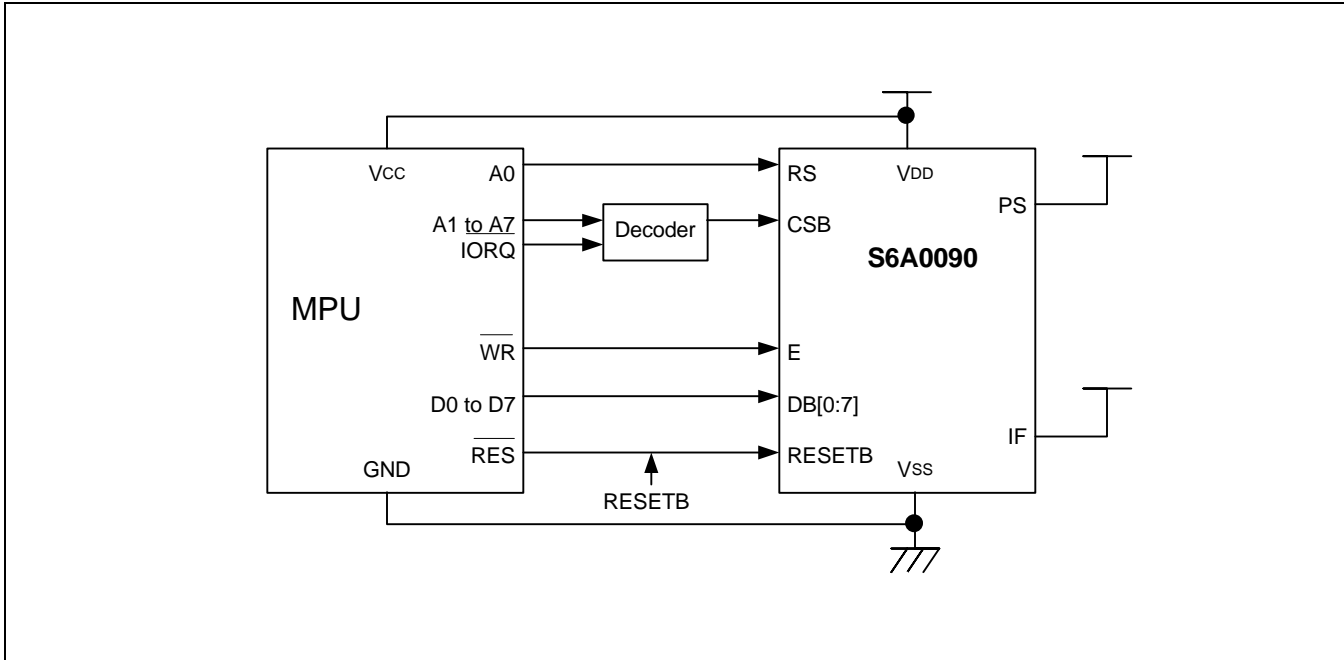

Figure 24. Parallel Interfacing with 8080-series Microprocessors

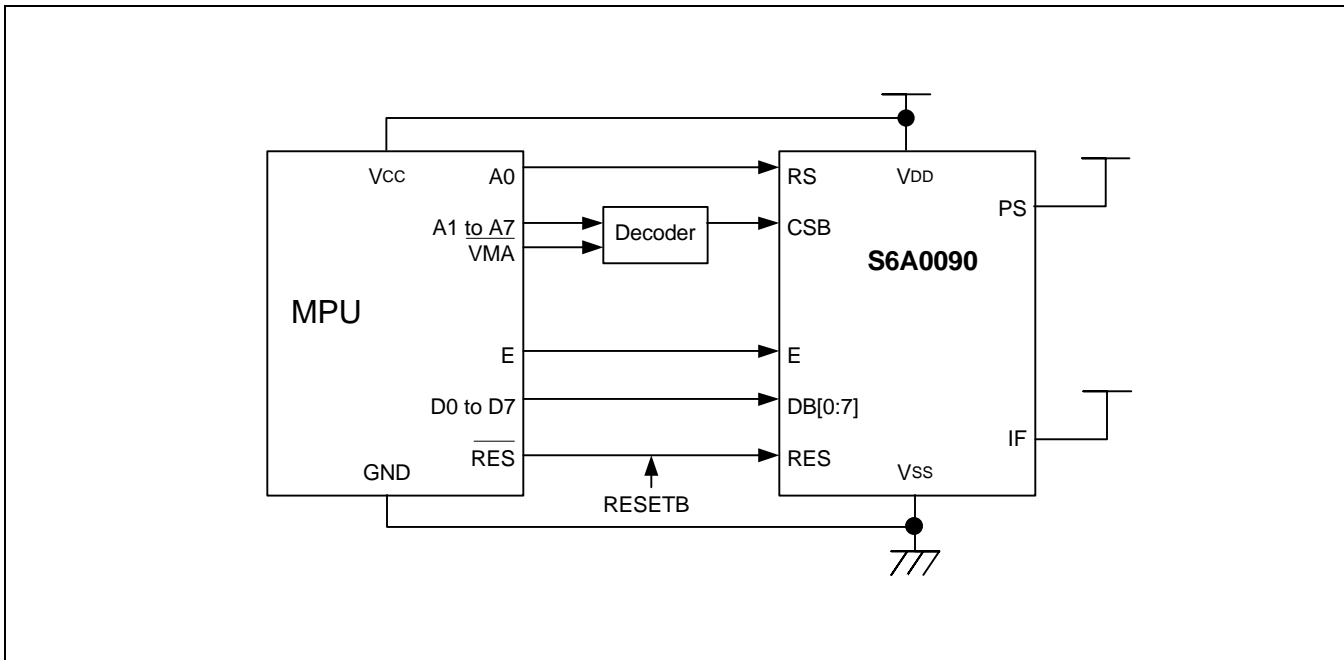

Figure 25. Parallel Interfacing with 6800-series Microprocessors



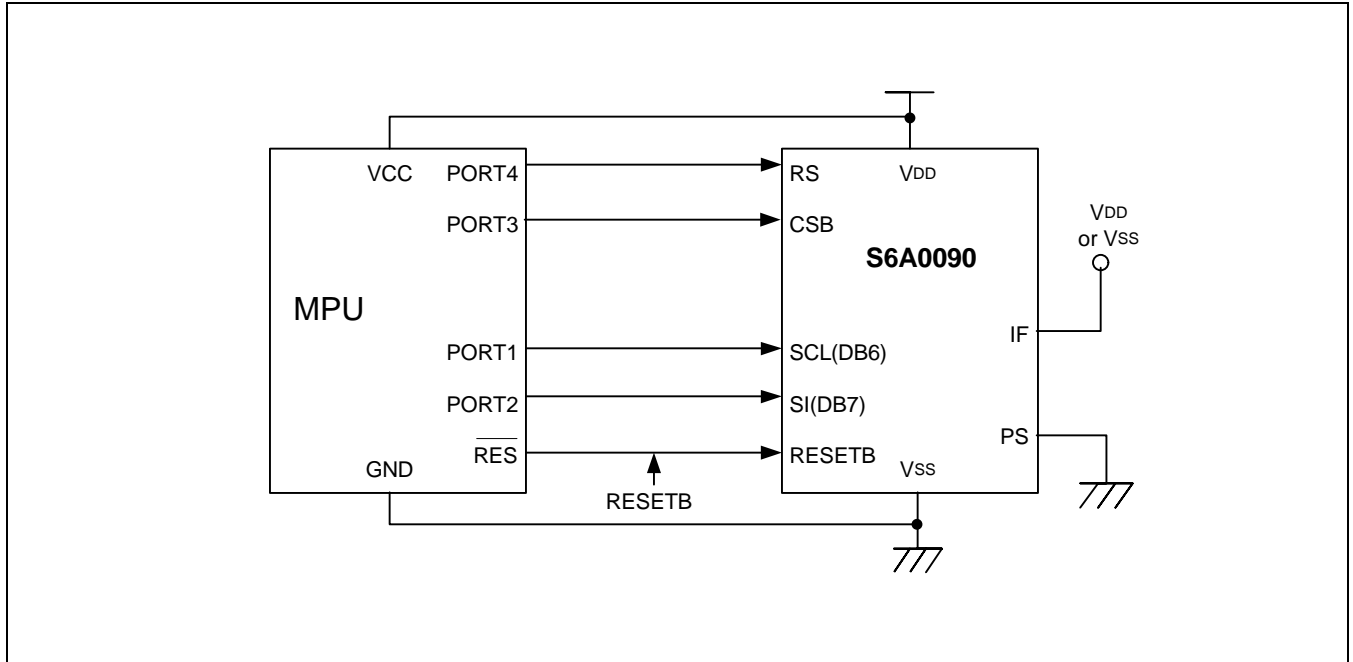

Figure 26. Clock Synchronized Serial Interfacing with any Microprocessor

APPLICATION INFORMATION FOR LCD PANEL

Chip Bottom & Lower View (S (COM) = "0", BID (SEG) = "0")

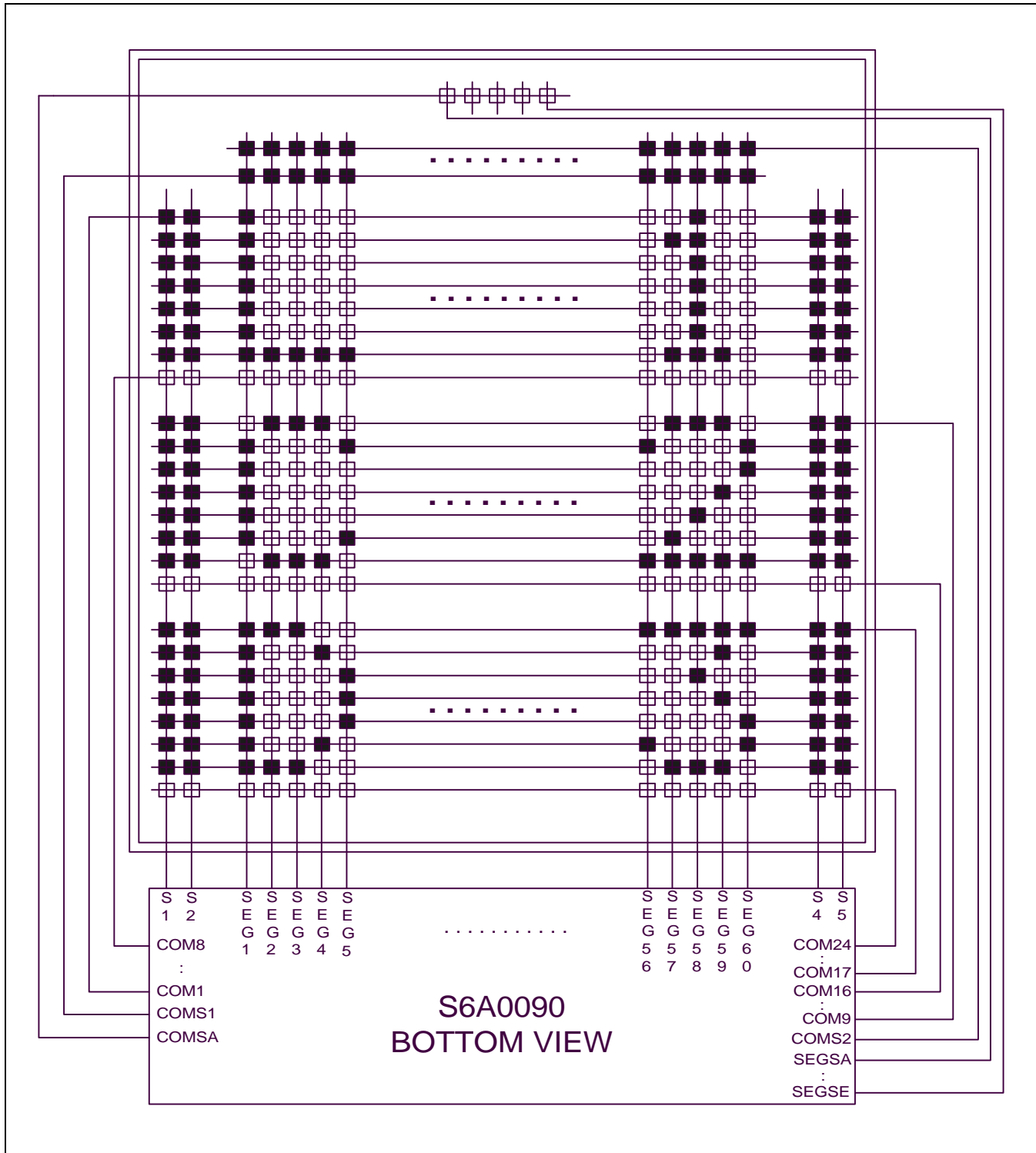

Figure 27. Chip Bottom & Lower View (S (COM) = "0", BID (SEG) = "0")

Chip Bottom & Upper View (S (COM) = "1", BID (SEG) = "1")

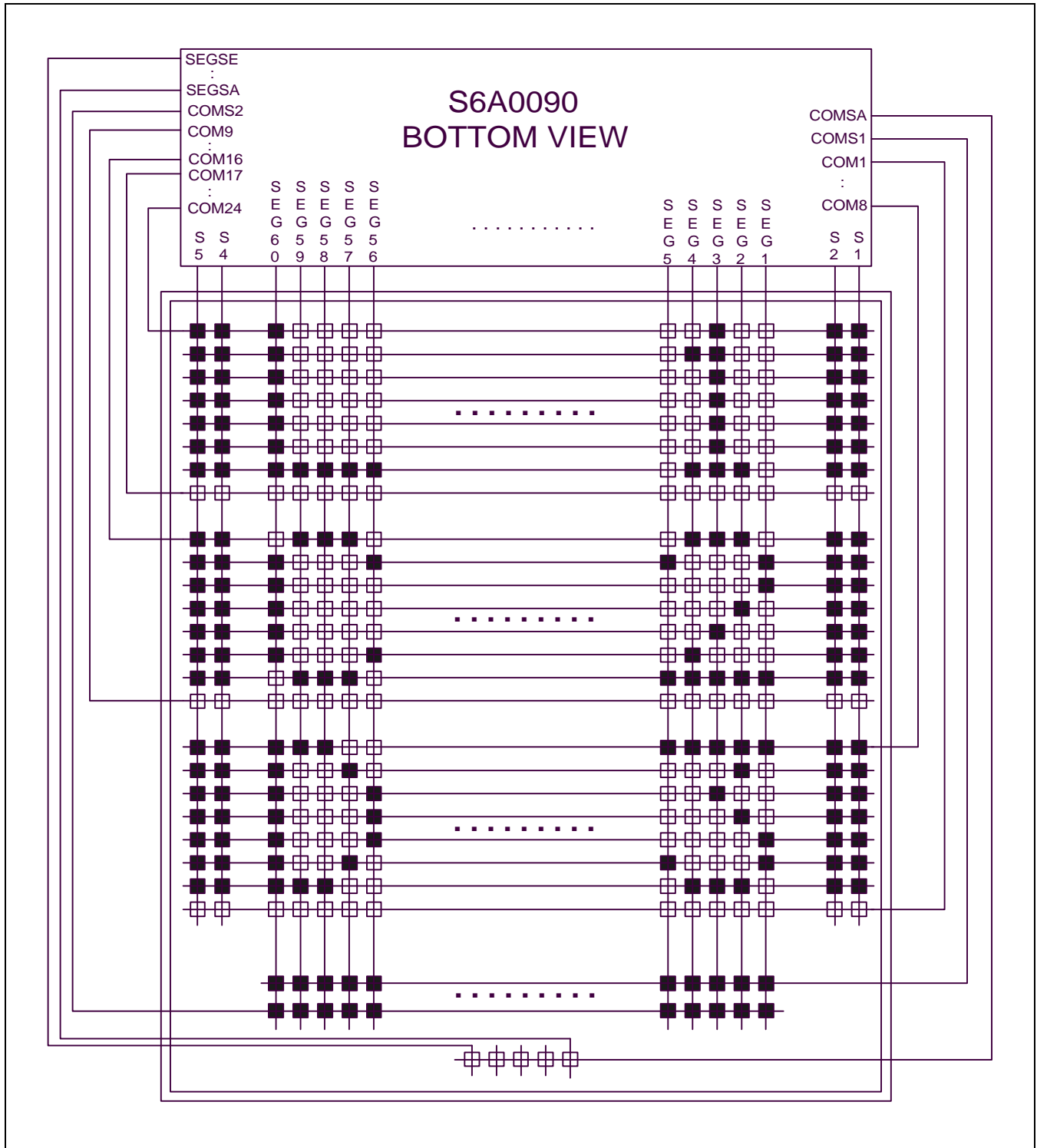

Figure 28. Chip Bottom & Upper View (S (COM) = "1", BID (SEG) = "1")

Chip Top & Lower View (S (COM) = "0", BID (SEG) = "1")

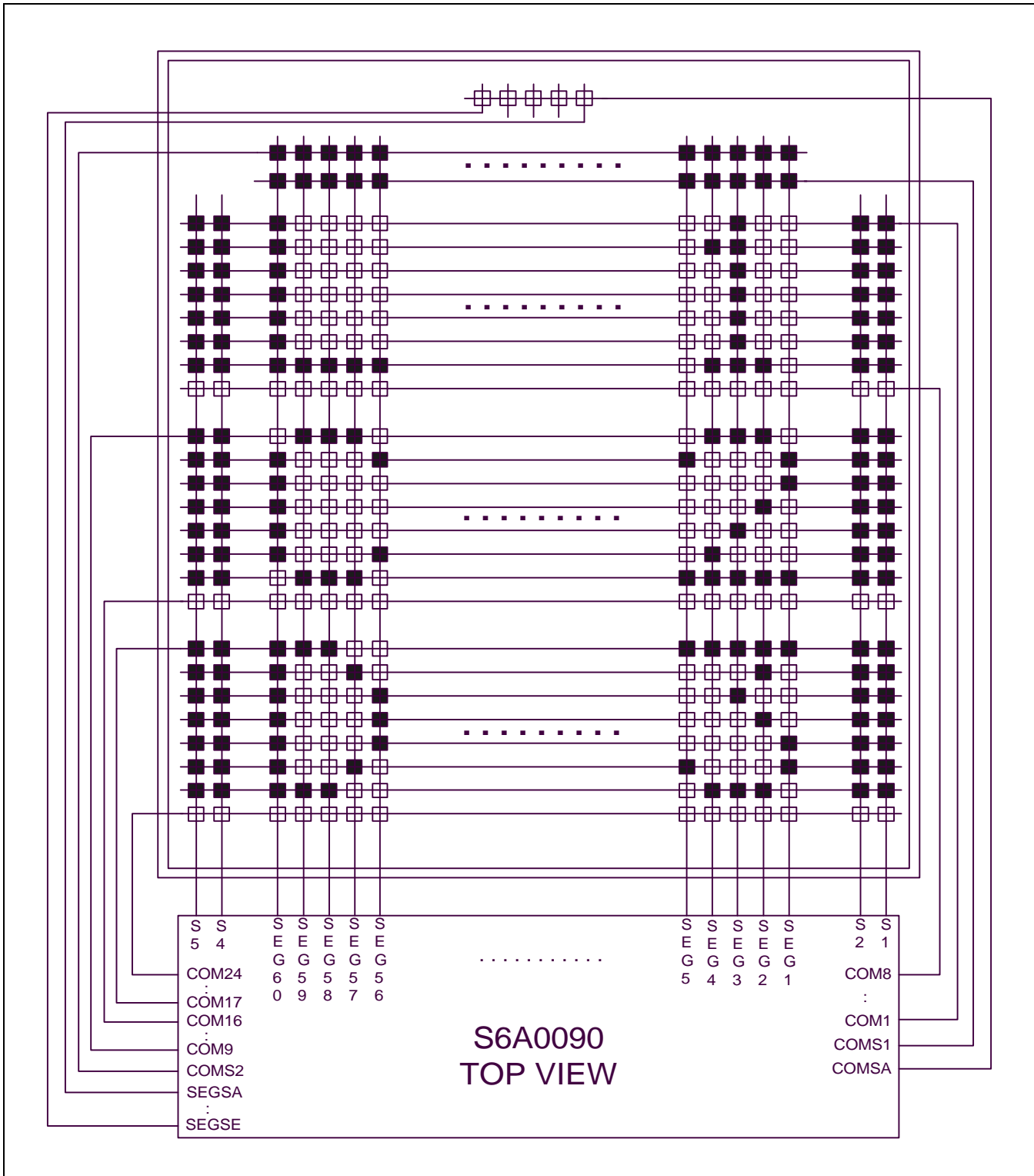

Figure 29. Chip Bottom & Lower View (S (COM) = "0", BID (SEG) = "1")

Chip Top & Upper View (S (COM) = "1", BID (SEG) = "0")

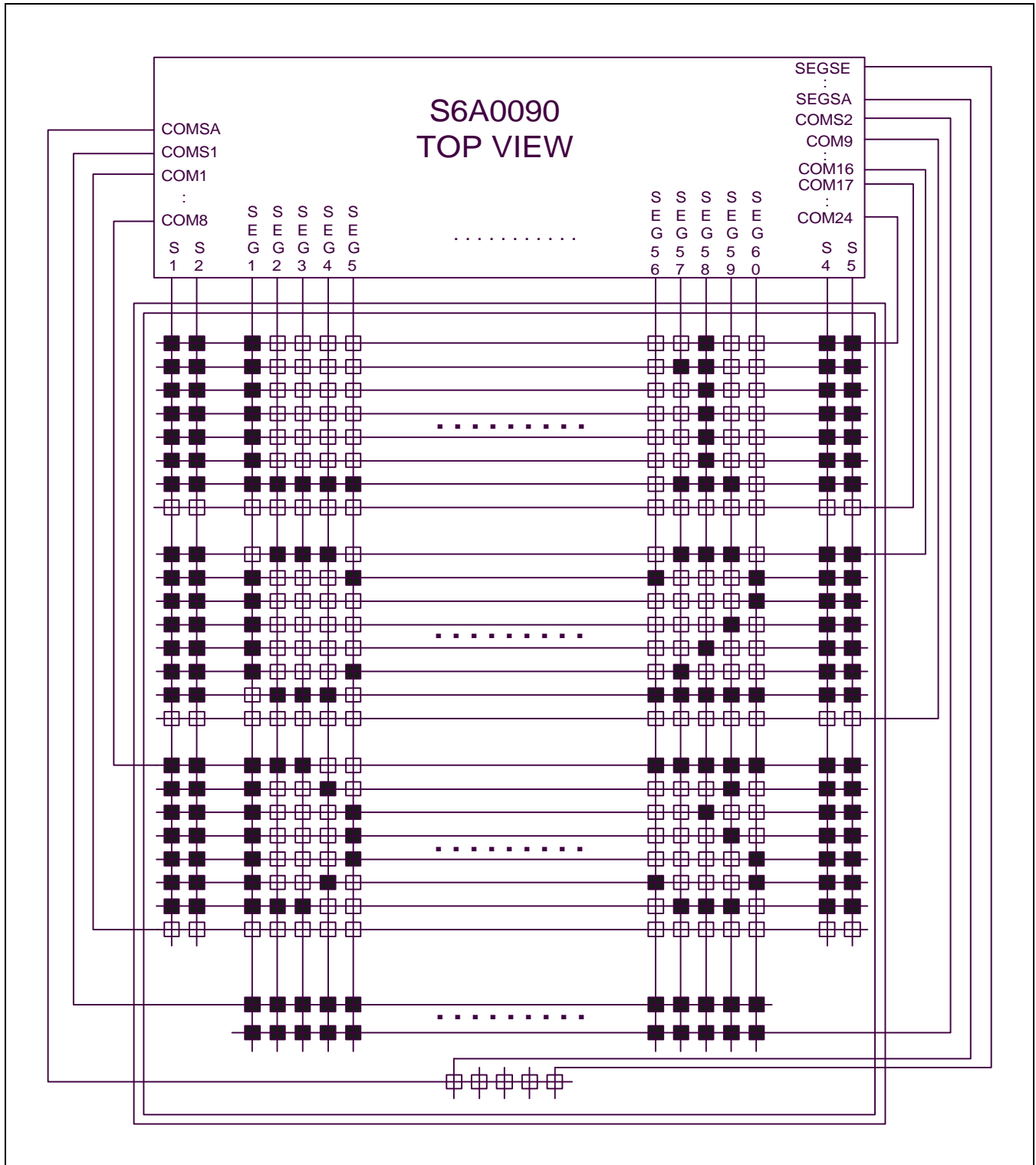

Figure 30. Chip Bottom & Upper View (S (COM) = "1", BID (SEG) = "0")

### FRAME FREQUENCY

#### 1/18 Duty (2-line Mode)

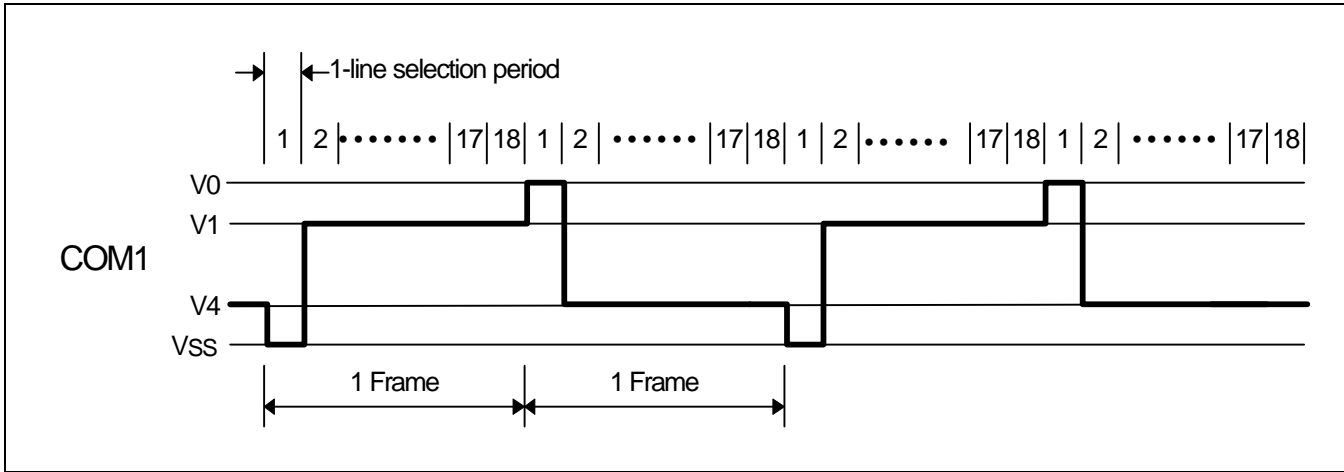

Figure 31. 1/18 Duty (2-line Mode)

1-line Selection Period = 13 Clocks

One Frame =  $13 \times 18 \times 43.2 \mu\text{s} = 10.0 \text{ ms}$  (1 Clock =  $43.2 \mu\text{s}$  at  $f_{\text{osc}} = 23.4 \text{ kHz}$ )

Frame Frequency =  $1 / 10.0 \text{ ms} = 100 \text{ Hz}$

#### 1/26 Duty (3-line Mode)

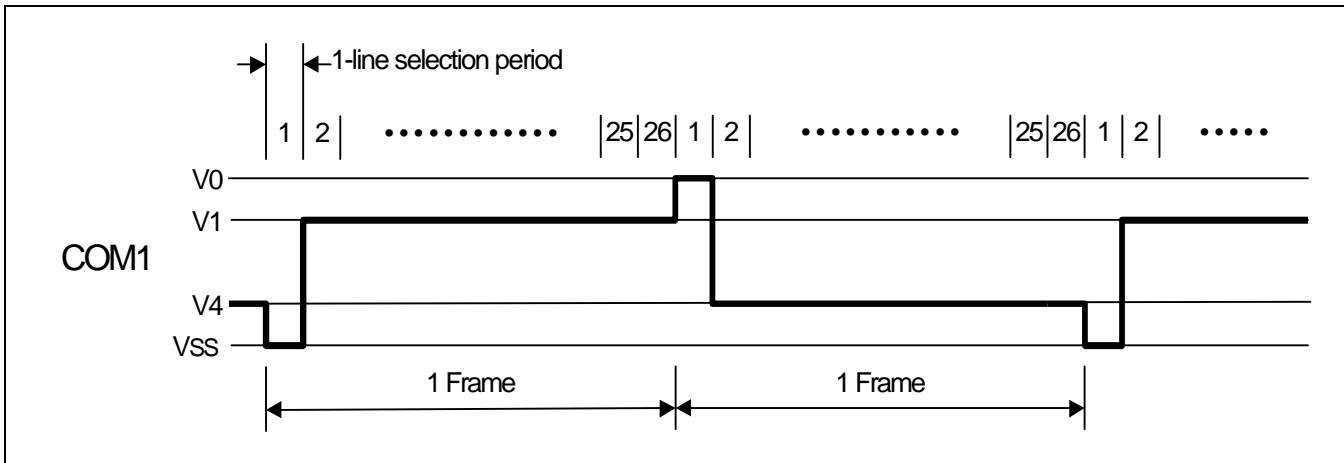

Figure 32. 1/26 Duty (3-line Mode)

1-line Selection Period = 13 Clocks

One Frame =  $13 \times 26 \times 29.5 \mu\text{s} = 10.0 \text{ ms}$  (1 Clock =  $29.5 \mu\text{s}$  at  $f_{\text{osc}} = 33.8 \text{ kHz}$ )

Frame Frequency =  $1 / 10.0 \text{ ms} = 100 \text{ Hz}$

\* Test Condition: Temperature (25°C & 85°C), 2-line & 3-line Mode, No Load

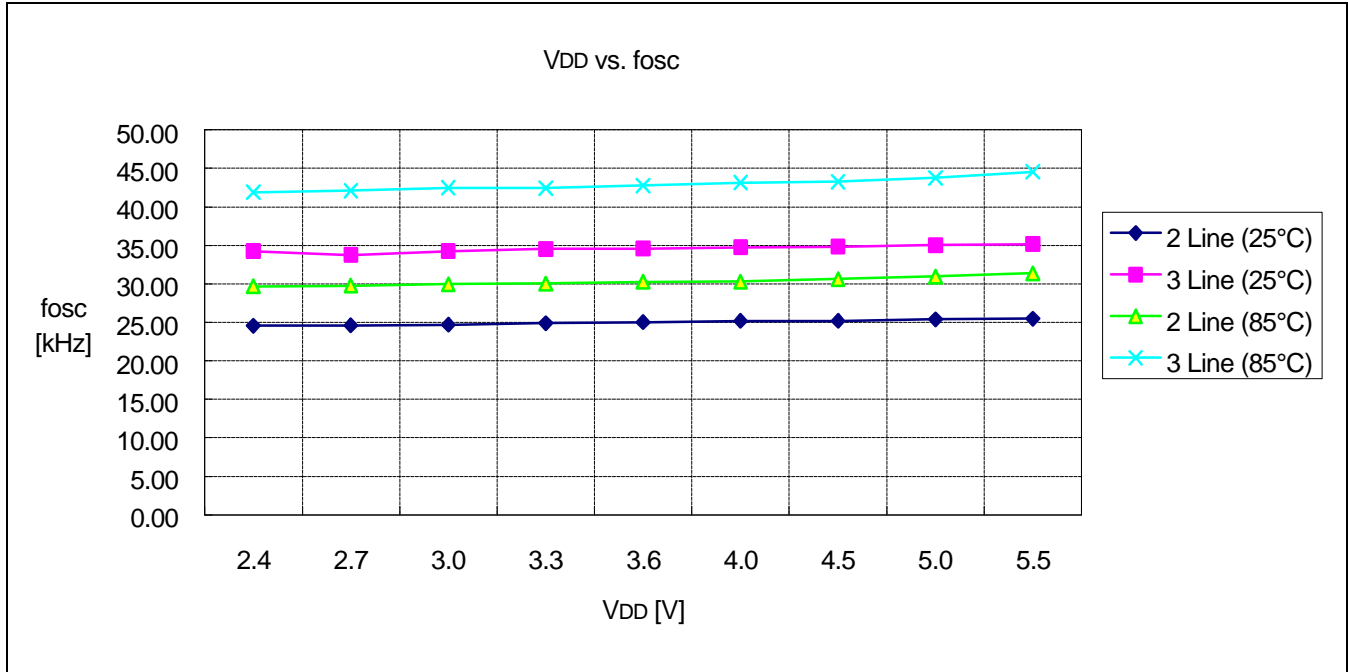

Figure 33. VDD vs. fosc

## MAXIMUM ABSOLUTE RATINGS

Table 14. Maximum Absolute Ratings

Characteristic	Symbol	Value	Unit
Power supply voltage (1)	VDD	-0.3 to +7.0	V
Power supply voltage (2)	VOUT, V0	-0.3 to +13.0	V
Power supply voltage (3)	V1, V2, V3, V4	-0.3 to V0	V
Operating temperature	TOPR	-30 to 85	°C
Storage temperature	TSTG	-55 to 125	°C

\* NOTE1: Voltage greater than above may damage the circuit.

\* NOTE2: All the voltage levels are based on VSS = 0V.

\* NOTE3: Voltage level: VOUT ≥ V0 ≥ VDD ≥ VSS  
 V0 ≥ V1 ≥ V2 ≥ V3 ≥ V4 ≥ VSS

## ELECTRICAL CHARACTERISTICS

### DC CHARACTERISTICS

Table 15. DC Characteristics

(V<sub>DD</sub> = 2.4V to 3.6V, Ta = -30 to +85°C)

Item	Symbol	Condition	Min.	Typ.	Max.	Unit
Operating voltage	V <sub>DD</sub>	-	2.4	-	3.6	V
Supply current (V <sub>DD</sub> = 3V, Ta = 25°C)	I <sub>DD1</sub>	Display operation V <sub>LCD</sub> = 6V without load No access from MPU	-	-	80	μA
	I <sub>DD2</sub>	Standby operation, without load oscillator ON, power OFF	-	-	10	
	I <sub>DD3</sub>	Sleep operation, without load oscillator OFF, power save ON	-	-	5	
Input voltage	V <sub>IH</sub>	-	0.8V <sub>DD</sub>	-	V <sub>DD</sub>	V
	V <sub>IL</sub>	-	V <sub>SS</sub>	-	0.2V <sub>DD</sub>	
Input leakage current	I <sub>IL</sub>	V <sub>IN</sub> = 0V to V <sub>DD</sub>	-1	-	1	μA
RON resistance	R <sub>COM</sub>	I <sub>o</sub> = ± 50μA	-	-	5	kΩ
	R <sub>SEG</sub>	I <sub>o</sub> = ± 50μA	-	-	10	
Frame frequency (internal OSC)	f <sub>FR</sub>	V <sub>DD</sub> = 3V, Ta = 25°C	70	100	130	Hz
External clock frequency	f <sub>ck</sub>	Display of 2-line mode	-	23.4	-	kHz
		Display of 3-line mode	-	33.8	-	
Voltage converter V <sub>DD</sub> 2 or 3 times	V <sub>OUT2/3</sub>	Ta = 25°C, C1 = 1μF without load	95	99	-	%
Voltage regulator reference voltage	V <sub>REF</sub>	Ta = 25°C	1.94	2.0	2.06	V
LCD driving voltage	V <sub>LCD</sub>	V <sub>LCD</sub> = V <sub>O</sub> - V <sub>SS</sub>	4.0	-	11.0	



Table 15. DC Characteristics (Continued)

(VDD = 3.6V to 5.5V, Ta = -30 to +85°C)

Item	Symbol	Condition	Min.	Typ.	Max.	Unit
Operating voltage	VDD	-	3.6	-	5.5	V
Supply current (VDD = 5V, Ta = 25°C)	IDD1	Display operation VLCD = 6V without load No access from MPU	-	-	100	μA
	IDD2	Standby operation, without load oscillator ON, power OFF	-	-	20	
	IDD3	sleep operation, without load oscillator OFF, power save ON	-	-	10	
Input voltage	VIH	-	0.8VDD	-	VDD	V
	VIL	-	VSS	-	0.2VDD	
Input leakage current	IIL	VIN = 0V to VDD	-1	-	1	μA
RON resistance	RCOM	Io = ± 50uA	-	-	5	kΩ
	RSEG	Io = ± 50uA	-	-	10	
Frame frequency (internal OSC)	fFR	VDD = 5V, Ta = 25°C	70	100	130	Hz
External clock frequency	Fck	Display of 2-line mode	-	23.4	-	kHz
		Display of 3-line mode	-	33.8	-	
Voltage converter VDD 2 times	VOUT2	Ta = 25°C, C1 = 1μF without load	95	99	-	%
Voltage regulator reference voltage	VREF	Ta = 25°C	1.94	2.0	2.06	V
LCD driving voltage	VLCD	VLCD = V0 - VSS	4.0	-	11.0	

\* NOTE: When power supply (VDD) range is 3.6V to 5.5V, the boosting of voltage converter is only 2 times available.

\* Test Condition: Temperature (25°C & 85°C), 3-line Mode, Three Times Boosting, Rb / Ra = 2, EV = 32

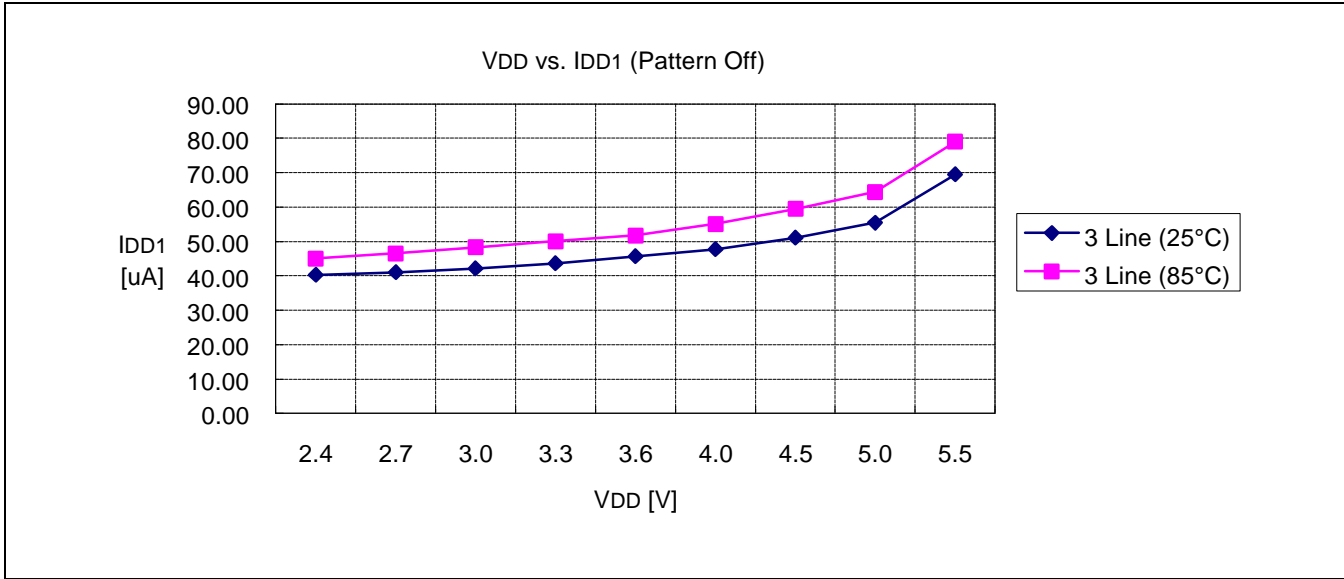

Figure 34. VDD vs. IDD1 (Pattern OFF)

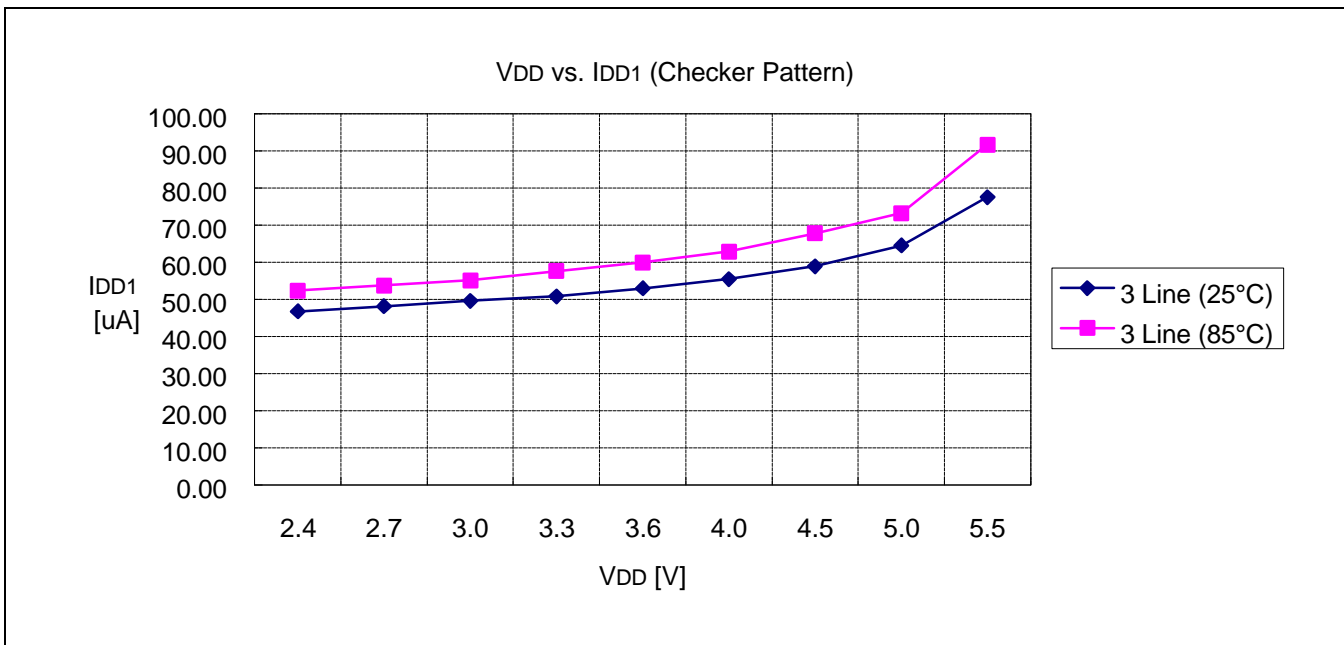

Figure 35. VDD vs. IDD1 (Checker Pattern)

## AC CHARACTERISTICS

### Write Bus Mode (68 Mode)

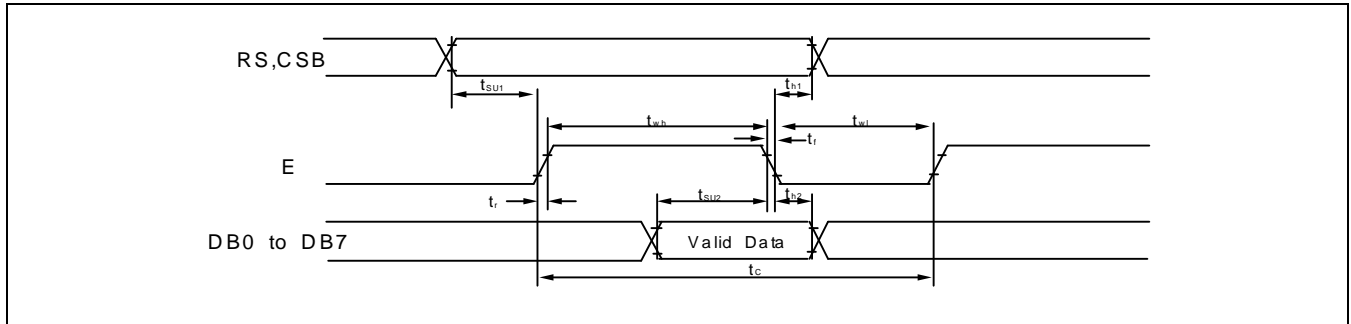

Figure 36. Write Bus Mode Timing Diagram (68 Mode)

( $V_{DD} = 2.4V$  to  $3.6V$ ,  $T_a = -30$  to  $+85^{\circ}C$ )

Mode	Characteristic	Symbol	Min.	Typ.	Max.	Unit
Write bus mode	E cycle time	$t_c$	650	-	-	ns
	Pulse rise / fall time	$t_r, t_f$	-	-	25	
	E pulse width high	$t_{wh}$	450	-	-	
	E pulse width low	$t_{wl}$	150	-	-	
	RS and CSB setup time	$t_{su1}$	60	-	-	
	RS and CSB hold time	$t_{h1}$	30	-	-	
	Data setup time	$t_{su2}$	100	-	-	
	Data hold time	$t_{h2}$	50	-	-	

( $V_{DD} = 3.6V$  to  $5.5V$ ,  $T_a = -30$  to  $+85^{\circ}C$ )

Mode	Characteristic	Symbol	Min.	Typ.	Max.	Unit
Write bus mode	E cycle time	$t_c$	500	-	-	ns
	Pulse rise / fall time	$t_r, t_f$	-	-	25	
	E pulse width high	$t_{wh}$	350	-	-	
	E pulse width low	$t_{wl}$	100	-	-	
	RS and CSB setup time	$t_{su1}$	60	-	-	
	RS and CSB hold time	$t_{h1}$	10	-	-	
	Data setup time	$t_{su2}$	100	-	-	
	Data hold time	$t_{h2}$	20	-	-	

**Write Bus Mode (80 Mode)**

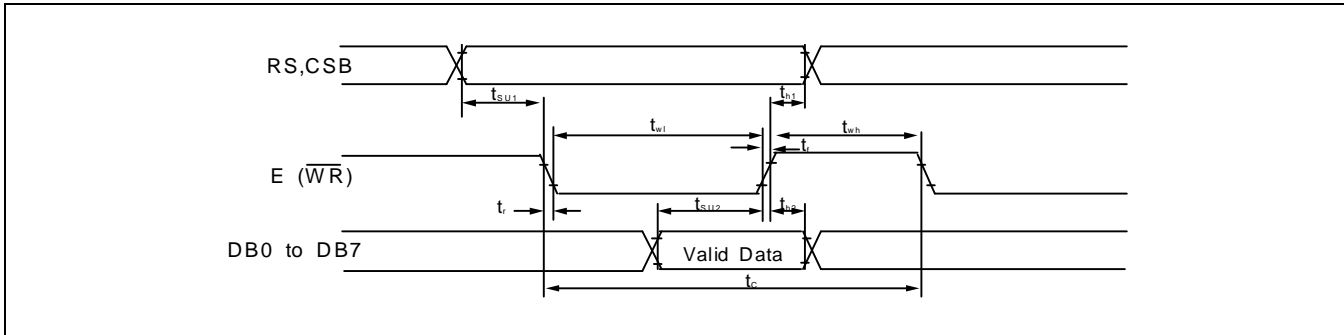

**Figure 37. Write Bus Mode Timing Diagram (80 Mode)**

( $V_{DD} = 2.4V$  to  $3.6V$ ,  $T_a = -30$  to  $+85^{\circ}C$ )

Mode	Characteristic	Symbol	Min.	Typ.	Max.	Unit
Write bus mode	E cycle time	$t_c$	650	-	-	ns
	Pulse rise / fall time	$t_r, t_f$	-	-	25	
	E pulse width high	$t_{wh}$	150	-	-	
	E pulse width low	$t_{wl}$	450	-	-	
	RS and CSB setup time	$t_{su1}$	60	-	-	
	RS and CSB hold time	$t_{h1}$	30	-	-	
	Data setup time	$t_{su2}$	100	-	-	
Data hold time	$t_{h2}$	50	-	-		

( $V_{DD} = 3.6V$  to  $5.5V$ ,  $T_a = -30$  to  $+85^{\circ}C$ )

Mode	Characteristic	Symbol	Min.	Typ.	Max.	Unit
Write bus mode	E cycle time	$t_c$	500	-	-	ns
	Pulse rise / fall time	$t_r, t_f$	-	-	25	
	E pulse width high	$t_{wh}$	100	-	-	
	E pulse width low	$t_{wl}$	350	-	-	
	RS and CSB setup time	$t_{su1}$	60	-	-	
	RS and CSB hold time	$t_{h1}$	10	-	-	
	Data setup time	$t_{su2}$	100	-	-	
Data hold time	$t_{h2}$	20	-	-		

**Clock Synchronized Serial Mode**

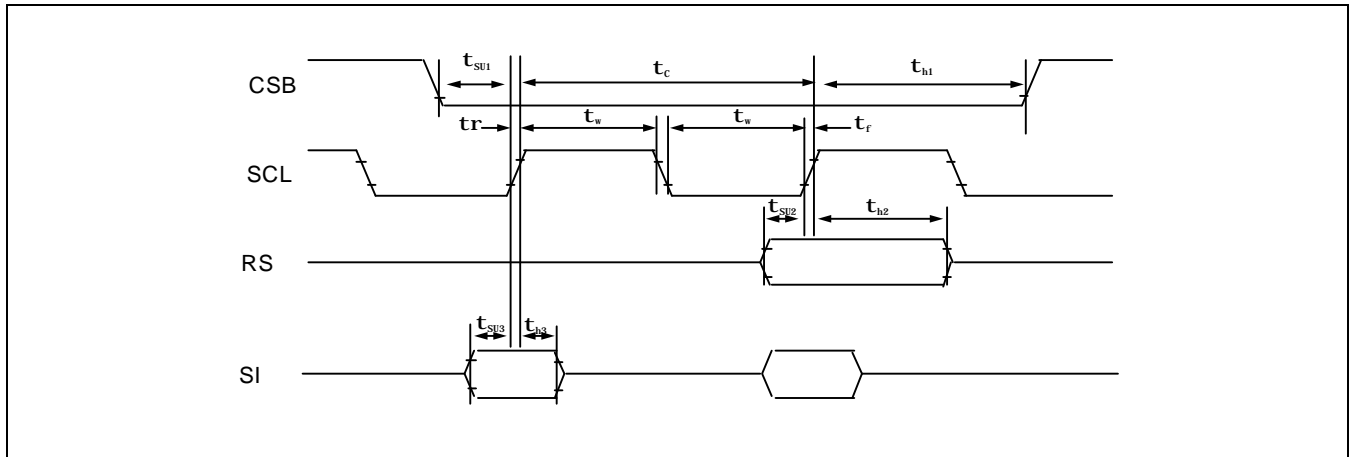

**Figure 38. Clock Synchronized Serial Interface Mode Timing Diagram**

(VDD = 2.4V to 3.6V, Ta = -30 to +85°C)

Mode	Characteristic	Symbol	Min.	Typ.	Max.	Unit
Clock synchronized serial interface mode	SCL clock cycle time	$t_c$	1000	-	-	ns
	Pulse rise / fall time	$t_r, t_f$	-	-	25	
	SCL clock width (high, low)	$t_w$	300	-	-	
	CSB setup time	$t_{su1}$	150	-	-	
	CSB hold time	$t_{h1}$	700	-	-	
	RS data setup time	$t_{su2}$	50	-	-	
	RS data hold time	$t_{h2}$	300	-	-	
	SI data setup time	$t_{su3}$	50	-	-	
SI data hold time	$t_{h3}$	50	-	-		

**Write Bus & Serial Mode (Typical 5V)**■ **68 Bus Mode**(V<sub>DD</sub> = 3.6V to 5.5V, T<sub>a</sub> = -30 to +85°C)

Mode	Characteristic	Symbol	Min.	Typ.	Max.	Unit
Write bus mode	E cycle time	t <sub>c</sub>	350	-	-	ns
	Pulse rise / fall time	t <sub>r,tf</sub>	-	-	25	
	E pulse width high	t <sub>wh</sub>	250	-	-	
	E pulse width low	t <sub>wl</sub>	1000	-	-	
	RS and CSB setup time	t <sub>su1</sub>	40	-	-	
	RS and CSB hold time	t <sub>h1</sub>	10	-	-	
	Data setup time	t <sub>su2</sub>	40	-	-	
	Data hold time	t <sub>h2</sub>	10	-	-	

■ **80 Bus Mode**(V<sub>DD</sub> = 3.6V to 5.5V, T<sub>a</sub> = -30 to +85°C)

Mode	Characteristic	Symbol	Min.	Typ.	Max.	Unit
Write bus mode	E cycle time	t <sub>c</sub>	350	-	-	ns
	Pulse rise / fall time	t <sub>r,tf</sub>	-	-	25	
	E pulse width high	t <sub>wh</sub>	100	-	-	
	E pulse width low	t <sub>wl</sub>	250	-	-	
	RS and CSB setup time	t <sub>su1</sub>	40	-	-	
	RS and CSB hold time	t <sub>h1</sub>	10	-	-	
	Data setup time	t <sub>su2</sub>	40	-	-	
	Data hold time	t <sub>h2</sub>	10	-	-	

■ **Serial Mode**(V<sub>DD</sub> = 3.6V to 5.5V, T<sub>a</sub> = -30 to +85°C)

Mode	Characteristic	Symbol	Min.	Typ.	Max.	Unit
Clock synchronized serial interface mode	SCL clock cycle time	t <sub>c</sub>	600	-	-	ns
	Pulse rise / fall time	t <sub>r,tf</sub>	-	-	25	
	SCL clock width (high, low)	t <sub>w</sub>	200	-	-	
	CSB setup time	t <sub>su1</sub>	100	-	-	
	CSB hold time	t <sub>h1</sub>	400	-	-	
	RS data setup time	t <sub>su2</sub>	40	-	-	
	RS data hold time	t <sub>h2</sub>	200	-	-	
	SI data setup time	t <sub>su3</sub>	40	-	-	
SI data hold time	t <sub>h3</sub>	40	-	-		