

ZXCT1010

Enhanced high-side current monitor

Description

The ZXCT1010 is a high side current sense monitor. Using this device eliminates the need to disrupt the ground plane when sensing a load current.

It is an enhanced version of the ZXCT1009 offering reduced typical output offset and improved accuracy at low sense voltage.

Features

- Low cost, accurate high-side current sensing
- Output voltage scaling
- Up to 2.5V sense voltage
- 2.5V – 20V supply range
- 300nA typical offset current
- 3.5 μ A quiescent current
- 1% typical accuracy
- SOT23-5 package

Pinout information

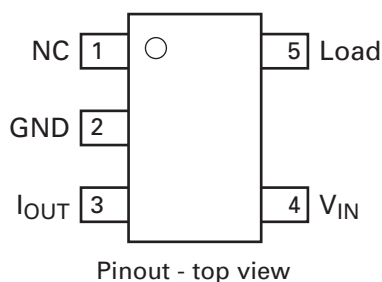

The wide input voltage range of 20V down to as low as 2.5V make it suitable for a range of applications. A minimum operating current of just 4 μ A, combined with its SOT23-5 package make suitable for portable battery equipment.

Applications

- Battery chargers
- Smart battery packs
- DC motor control
- Over current monitor
- Power management
- Programmable current source

Typical application circuit

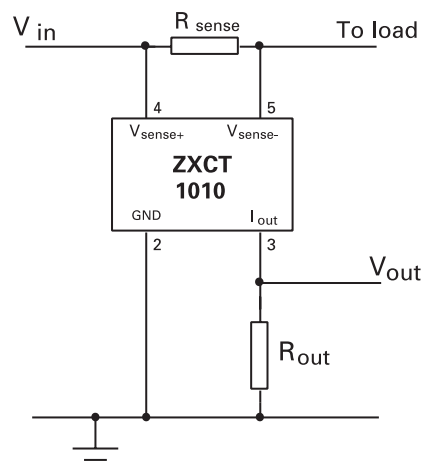

Ordering information

Device	Package	Device marking	Reel size (inches)	Tape width (mm)	Quantity per reel
ZXCT1010E5TA	SOT23-5	101	7	8	3000

Pin information

Pin	Name	Description
1	N/C	Not connection
2	GND	Ground connection
3	I _{OUT}	Output current, proportional to $V_{IN} - V_{LOAD}$
4	V _{SENSE+}	Supply voltage
5	V _{SENSE-}	Connection to load/battery

Absolute maximum ratings

Voltage on any pin (relative to GND pin)	-0.6 to 20V (relative to GND)
Continuous output current	25mA
Continuous sense voltage	$V_{IN} + 0.5V > V_{SENSE} > V_{IN} - 5V$
Ambient operating temperature range	-40 to 85°C
Storage temperature	-55 to 150°C
Package power dissipation	$T_{amb} = 25^{\circ}C$
SOT23-5	300mW

Operation above the absolute maximum rating may cause device failure. Operation at the absolute maximum ratings, for extended periods, may reduce device reliability.

ZXCT1010

Electrical characteristics

Test conditions $T_{amb} = 25^{\circ}\text{C}$, $V_{IN} = 5\text{V}$, $R_{OUT} = 100\Omega$

Symbol	Parameter	Conditions	Limits			Unit
			Min.	Typ.	Max.	
V_{IN}	V_{CC} range		2.5		20	V
$I_{OUT}^{(a)}$	Output current	$V_{SENSE} = 0\text{V}$	0	0.3	10	μA
		$V_{SENSE} = 10\text{mV}$	85	100	115	μA
		$V_{SENSE} = 100\text{mV}$	0.975	1.00	1.025	mA
		$V_{SENSE} = 200\text{mV}$	1.95	2.00	2.05	mA
		$V_{SENSE} = 1\text{V}$	9.7	10.0	10.3	mA
I_Q	Ground pin current	$V_{SENSE} = 0\text{V}$		3.5	8	μA
$V_{SENSE}^{(b)}$	Sense voltage		0		2500	mV
I_{SENSE-}	V_{SENSE-} input current				100	nA
Acc	Accuracy	$R_{SENSE} = 0.1\Omega$ $V_{SENSE} = 200\text{mV}$	-2.5		2.5	%
Gm	Transconductance, I_{OUT}/V_{SENSE}			10000		$\mu\text{A}/\text{V}$
BW	Bandwidth	RF $P_{IN} = -20\text{dBm}^{(c)}$				
		$V_{SENSE} = 10\text{mV DC}$ $V_{SENSE} = 100\text{mV DC}$		300 2		kHz MHz

NOTES:

(a) Includes input offset voltage contribution

(b) $V_{SENSE} = V_{IN} - V_{LOAD}$

(c) $-20\text{dBm} = 63\text{mVp-p}$ into 50Ω

Typical characteristics

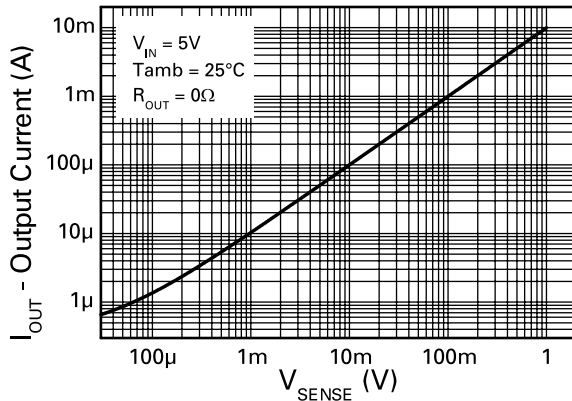

Typical Output v Sense Voltage

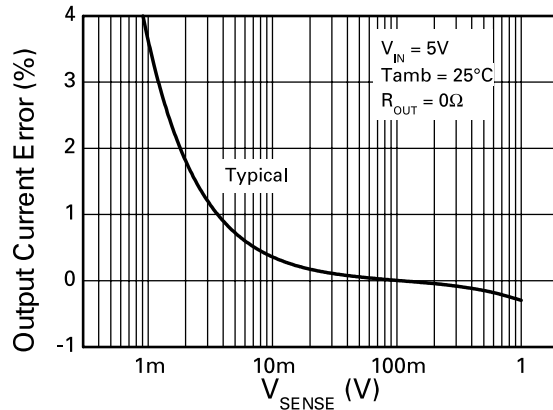

Error v Sense Voltage

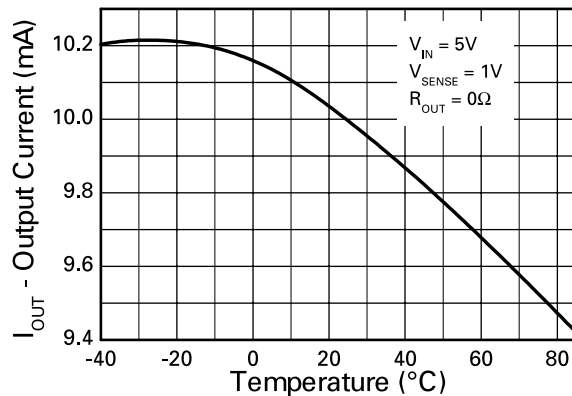

Output Current v Temperature

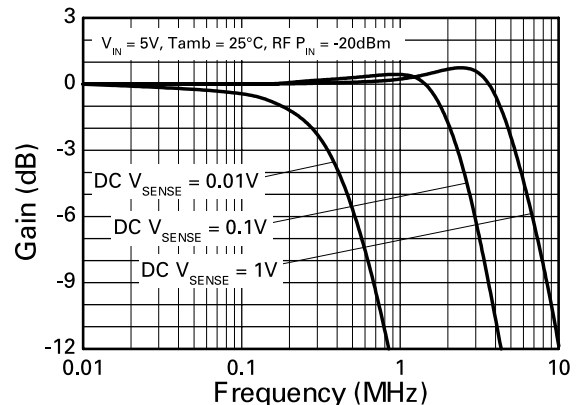

Frequency Response

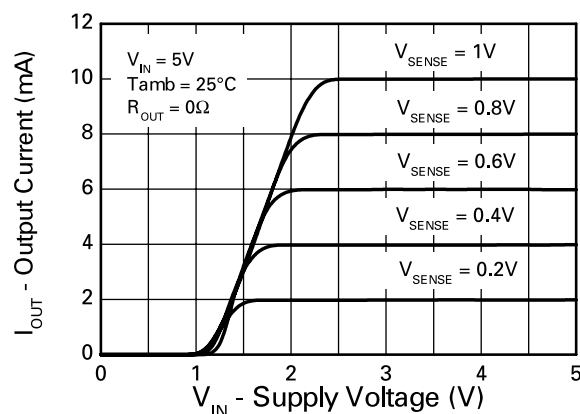

Transfer Characteristic

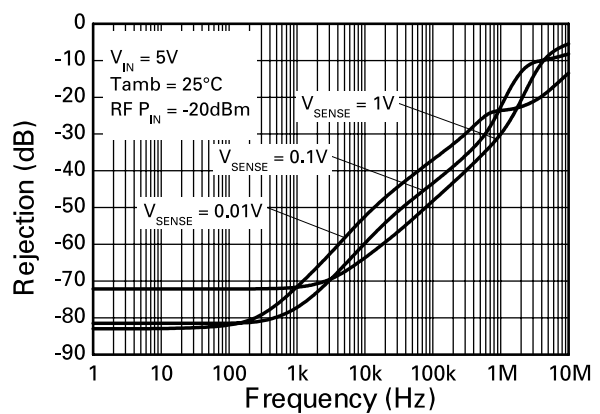

Common Mode Rejection

Power dissipation

The maximum allowable power dissipation of the device for normal operation (P_{max}), is a function of the package junction to ambient thermal resistance (Θ_{ja}), maximum junction temperature (T_{jmax}), and ambient temperature (T_{amb}), according to the expression:

$$P_{max} = (T_{jmax} - T_{amb}) / \Theta_{ja}$$

The device power dissipation, P_D is given by the expression:

$$P_D = I_{OUT} \cdot (V_{IN} - V_{OUT}) \text{ Watts}$$

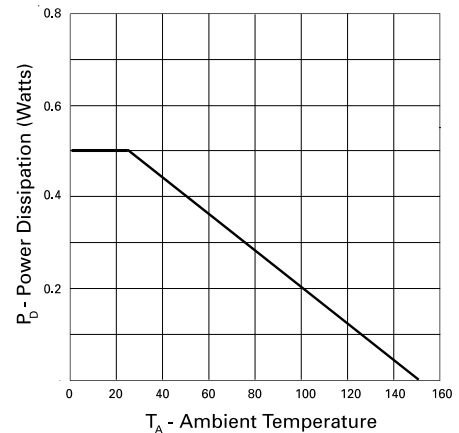

Applications information

The following lines describe how to scale a load current to an output voltage.

$$V_{SENSE} = V_{IN} - V_{LOAD}$$

$$V_{OUT} = 0.01 \times V_{SENSE} \times R_{OUT}^{(1)}$$

For example:

A 1A current is to be represented by a 100mV output voltage:

- 1 Choose the value of R_{SENSE} to give $50mV > V_{SENSE} > 500mV$ at full load.

For example $V_{SENSE} = 100mV$ at 1.0A. $R_{SENSE} = 0.1/1.0 \Rightarrow 0.1\Omega$.

- 2 Choose R_{OUT} to give $V_{OUT} = 100mV$, when $V_{SENSE} = 100mV$.

Rearranging ⁽¹⁾ for R_{OUT} gives:

$$R_{OUT} = V_{OUT} / (V_{SENSE} \times 0.01)$$

$$R_{OUT} = 0.1 / (0.1 \times 0.01) = 100\Omega$$

Schematic diagram

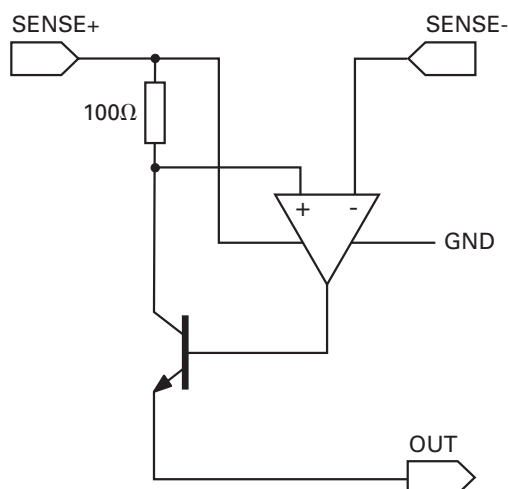

Typical circuit application

Where R_{LOAD} represents any load including DC motors, a charging battery or further circuitry that requires monitoring, R_{SENSE} can be selected on specific requirements of accuracy, size and power rating.

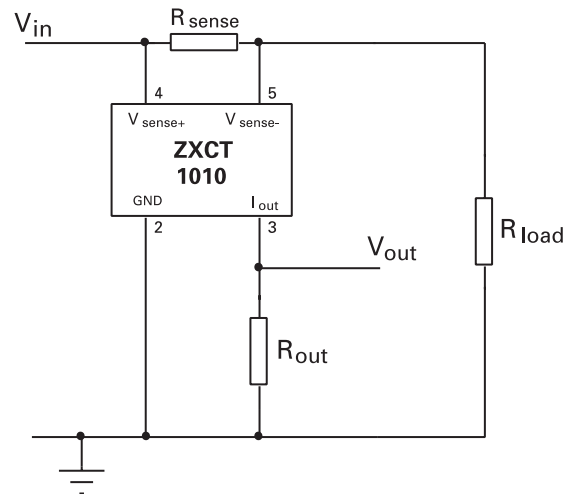

Li-Ion charger circuit

The figure below shows the ZXCT1010 supporting the Benchmarq bq2954 charge management IC. Most of the support components for the bq2954 are omitted for clarity. This design also uses the Zetex FZT789A high current Super- β PNP as the switching transistor in the DC-DC step down converter and the FMMT451 as the drive NPN for the FZT789A. The circuit can be configured to charge up to four Li-Ion cells at a charge current of 1.25A. Charge can be terminated on maximum voltage, selectable minimum current, or maximum time out. Switching frequency of the PWM loop is approximately 120kHz.

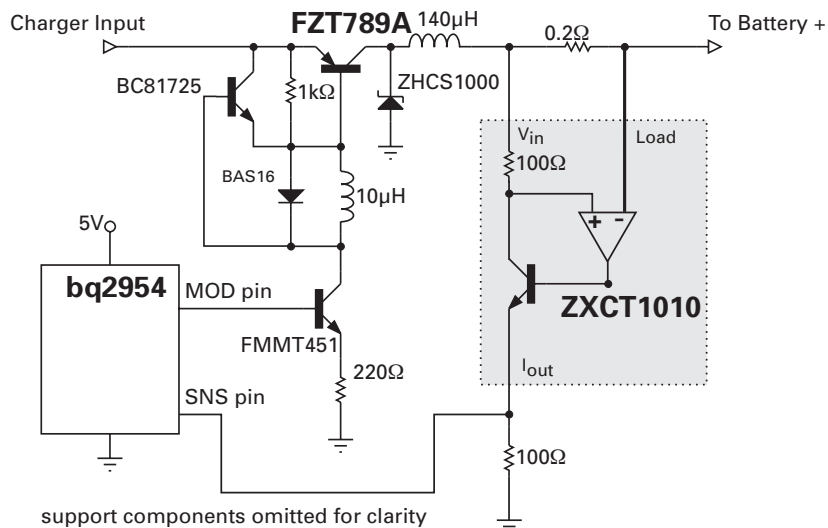

Bi-directional current sensing

The ZXCT1010 can be used to measure current bi-directionally, if two devices are connected as shown opposite.

If the voltage V_1 is positive with respect to the voltage V_2 the lower device will be active, delivering a proportional output current to R_{OUT} . Due to the polarity of the voltage across R_{sense} , the upper device will be inactive and will not contribute to the current delivered to R_{OUT} . When V_2 is more positive than V_1 , current will be flowing in the opposite direction, causing the upper device to be active instead.

Non-linearity will be apparent at small values of V_{SENSE} due to offset current contribution. Devices can use separate output resistors if the current direction is to be monitored independently.

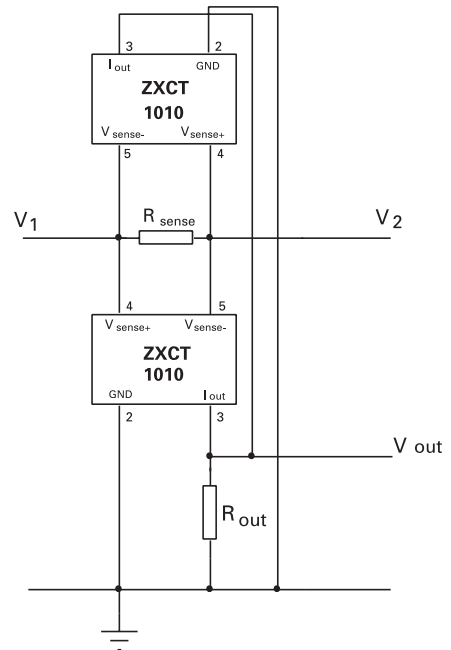

Bi-directional transfer function

Bidirectional Transfer Function

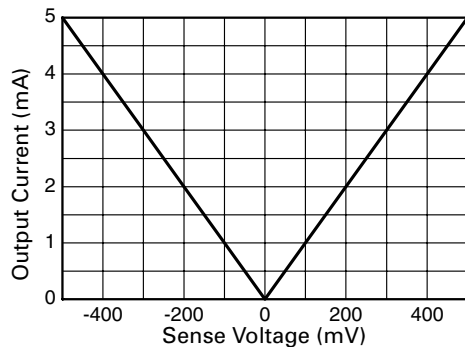

Output Current v Sense Voltage

PCB trace shunt resistor for low cost solution

The figure opposite shows output characteristics of the device when using a PCB resistive trace for a low cost solution in replacement for a conventional shunt resistor. The graph shows the linear rise in voltage across the resistor due to the PTC of the material and demonstrates how this rise in resistance value over temperature compensates for the NTC of the device.

The figure below shows a PCB layout suggestion. The resistor section is 25mm x 0.25mm giving approximately 150mW using 1oz copper. The data for the normalised graph was obtained using a 1A load current and a 100W output resistor. An electronic version of the PCB layout is available at www.zetex.com/isense

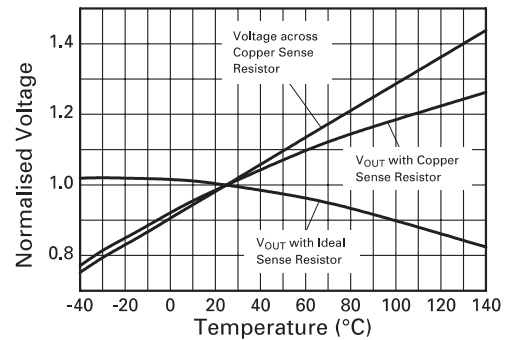

Effect of Sense Resistor Material on Temperature Performance

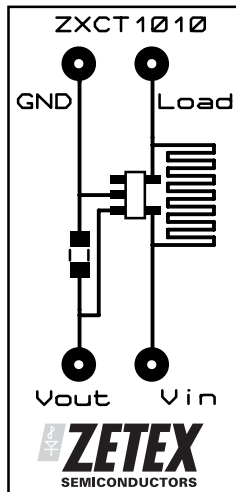

Layout shows area of shunt resistor compared to ZSOT23-5 package (not actual size).

Intentionally left blank

Package outline - SOT23-5

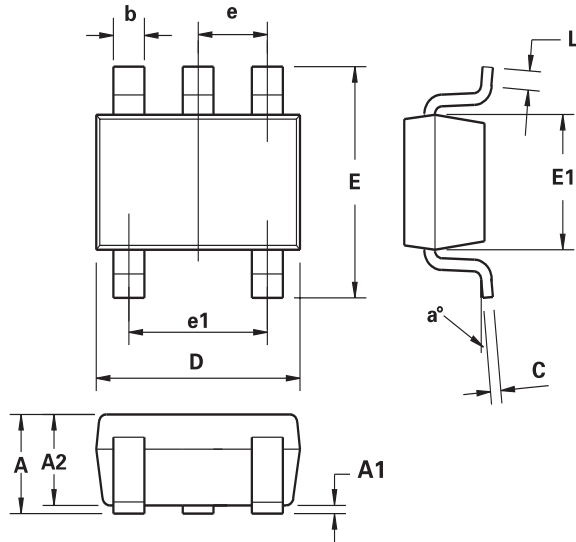

DIM	Millimeters		Inches	
	Min.	Max.	Min.	Max.
A	0.90	1.45	0.0354	0.0570
A1	0.00	0.15	0.00	0.0059
A2	0.90	1.30	0.0354	0.0511
b	0.20	0.50	0.0078	0.0196
C	0.09	0.26	0.0035	0.0102
D	2.70	3.10	0.1062	0.1220
E	2.20	3.20	0.0866	0.1181
E1	1.30	1.80	0.0511	0.0708
e	0.95 REF		0.0374 REF	
e1	1.90 REF		0.0748 REF	
L	0.10	0.60	0.0039	0.0236
a°	0°	30°	0°	30°

Note: Controlling dimensions are in millimeters. Approximate dimensions are provided in inches

Europe	Americas	Asia Pacific	Corporate Headquarters
Zetex GmbH Streitfeldstraße 19 D-81673 München Germany	Zetex Inc 700 Veterans Memorial Highway Hauppauge, NY 11788 USA	Zetex (Asia Ltd) 3701-04 Metroplaza Tower 1 Hing Fong Road, Kwai Fong Hong Kong	Zetex Semiconductors plc Zetex Technology Park, Chadderton Oldham, OL9 9LL United Kingdom
Telefon: (49) 89 45 49 49 0 Fax: (49) 89 45 49 49 49 europe.sales@zetex.com	Telephone: (1) 631 360 2222 Fax: (1) 631 360 8222 usa.sales@zetex.com	Telephone: (852) 26100 611 Fax: (852) 24250 494 asia.sales@zetex.com	Telephone: (44) 161 622 4444 Fax: (44) 161 622 4446 hq@zetex.com

For international sales offices visit www.zetex.com/offices

Zetex products are distributed worldwide. For details, see www.zetex.com/salesnetwork

This publication is issued to provide outline information only which (unless agreed by the company in writing) may not be used, applied or reproduced for any purpose or form part of any order or contact or be regarded as a representation relating to the products or services concerned. The company reserves the right to alter without notice the specification, design, price or conditions of supply of any product or service.