

FEATURES

- 6 sided Continuous Shielding
- Synchronization and Output Trim
- Wide 2:1 Input Voltage Range
- Efficiency to 86%
- UL 1950 Approved
- CSA 22.9-950 Approved
- VDE / EN 60950 Approved
- >700,000 Hours MTBF

DESCRIPTIONS

The 2000 series is a family of compact 20 W, high performance DC/DC converters. These converters are specifically designed to provide the flexibility, power density, and reliability required to fulfill local power needs in applications ranging from telecom switch systems to portable instrumentation. 24 models operate over 2:1 input ranges of 9 to 18, 18 to 36 or 36 to 72 VDC; providing single, dual or triple output combinations of 5, 6, 12, 15, ± 12 , ± 15 , 5 ± 12 and 5 ± 15 VDC. All models are packaged in compact, low profile 3.0" X 2.56" X 0.75" metal cases.

OUTPUT CHARACTERISTICS

	Min	Typ	Max	Unit/Comments
Output Voltage Accuracy				
Single & Dual Outputs			± 1.0	% ¹
Triple Outputs - Primary			± 1.0	% ¹
- Auxiliaries			± 6.0	% ¹
Output Voltage Adjustment			± 5.0	% ¹ ;
Voltage Balance:				
Dual Outputs			± 0.5	%; Equal Output Loads
Triple Outputs (Auxiliaries)			± 50	mV; Equal Output Loads
Minimum Load			10%	Full Load
Line Regulation				
Single Outputs			± 0.5	% ²
Dual Outputs			± 0.4	% ²
Triple Outputs - Primary			± 0.2	% ²
- Auxiliaries			± 1.0	% ²
Load Regulation				
Single Outputs			± 0.5	% ³
Dual Outputs			± 0.5	% ³ ; Equal Loads
Triple Outputs - Primary			± 0.5	% ³
- Auxiliaries			± 5.0	% ³ ; Equal Loads
Ripple/Noise				
Single & Dual Output			± 1.0	% Pk-Pk of Vout
Triple Output Models				
Primary			100mV	Pk-Pk
Auxiliaries			± 1.0	% Pk-Pk of Vout
Short Circuit Protection				Continuous, Automatic Recovery
Transient Recovery Time			100	μ S to within 1% error band for 50% step load change
Temperature Coefficient			± 0.02	% per °C
Over Voltage Protection				See Model Selection Guide

2000 series

Single, Dual, Triple Output DC/DC Converter

INPUT CHARACTERISTICS

	Min	Typ	Max	Unit/Comments
Input Voltage Range				
12 VDC Input Models	9	12	18	VDC
24 VDC Input Models	18	24	36	VDC
48 VDC Input Models	36	48	72	VDC
Remote ON / OFF Control				
Supply ON				5.5 VDC or Open Circuit
Supply OFF				0 VDC to 0.8 VDC
Logic Referenced to Negative Input				
Input Filter				Pi Filter

GENERAL CHARACTERISTICS

	Min	Typ	Max	Unit/Comments
Switching Frequency	100			kHz
Isolation Voltage	500			VDC, 1 minute
Isolation Resistance	1000			Mohm, 500VDC
MTBF (MIL-HBK-217F)	700			Thousand Hours, +25°C, Ground Benign

¹ = Output voltage at nominal line & FL

² = % Output voltage measured from min. input line to maximum

³ = Output voltage measured from FL to 10% Load

How To ORDER

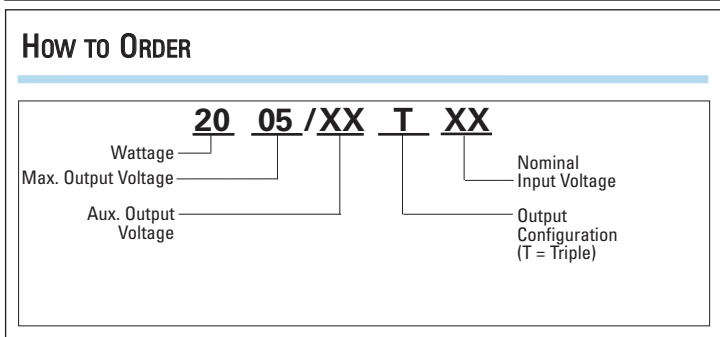
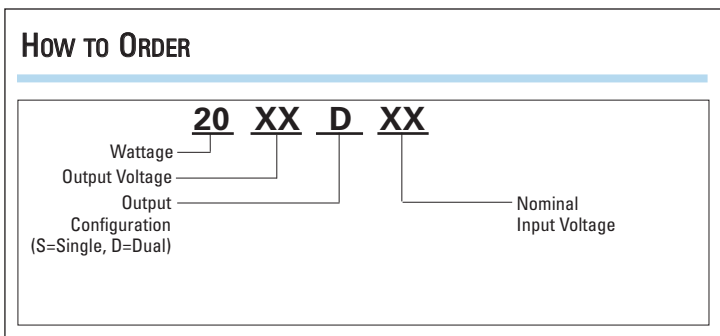

MODEL SELECTION CHART

Model	Nominal Input Voltage (VDC)	Input Voltage Range (VDC)	Input Current (mA) No Load	Input Current (mA) Full Load	Output Voltage (VDC)	Output Current (mA)	Output Over Voltage (VDC)	% Efficiency @ Full Load
2005S12	12	9 - 18	30	2200	5	4000	6.5	75
2005S24	24	18 - 36	30	1030	5	4000	6.5	81
2005S48	48	36 - 72	16	510	5	4000	6.5	81
2006S12	12	9 - 18	30	2160	6	3300	7.5	77
2006S24	24	18 - 36	30	1000	6	3300	7.5	83
2006S48	48	36 - 72	16	485	6	3300	7.5	86
2012S12	12	9 - 18	30	2140	12	1650	15.0	78
2012S24	24	18 - 36	30	1025	12	1650	15.0	80
2012S48	48	36 - 72	16	500	12	1650	15.0	83
2015S12	12	9 - 18	30	2160	15	1325	18.0	77
2015S24	24	18 - 36	30	1025	15	1325	18.0	81
2015S48	48	36 - 72	16	515	15	1325	18.0	81
2012D12	12	9 - 18	40	2140	±12	±825	±15.0	77
2012D24	24	18 - 36	30	1025	±12	±825	±15.0	80
2012D48	48	36 - 72	16	500	±12	±825	±15.0	83
2015D12	12	9 - 18	40	2140	±15	±660	±18.0	77
2015D24	24	18 - 36	30	1025	±15	±660	±18.0	81
2015D48	48	36 - 72	16	500	±15	±660	±18.0	83
2005/12T12	12	9 - 18	40	2220	5/±12	2000/±415	6.5/±15	75
2005/12T24	24	18 - 36	30	1050	5/±12	2000/±415	6.5/±15	79
2005/12T48	48	36 - 72	16	515	5/±12	2000/±415	6.5/±15	81
2005/15T12	12	9 - 18	40	2220	5/±15	2000/±300	6.5/±18	75
2005/15T24	24	18 - 36	30	1050	5/±15	2000/±300	6.5/±18	79
2005/15T48	48	36 - 72	16	515	5/±15	2000/±300	6.5/±18	81