

AIRPAX[®]

SERIES 6600 THERMOSTATS

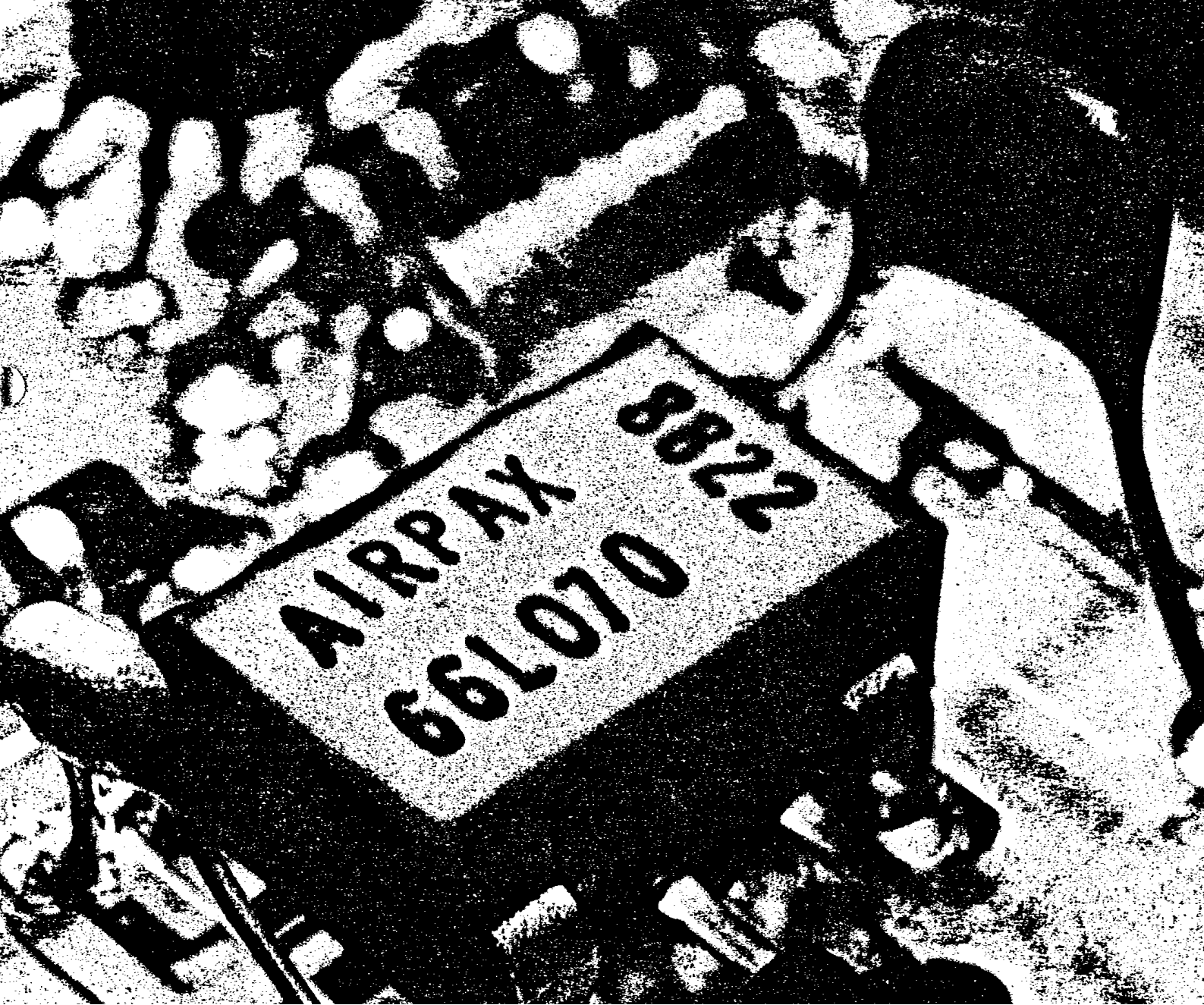

Series 6600 Thermostats

6600 P.C. Board Thermostat

The Airpax Series 6600 is a miniature bimetallic snap acting thermostat which provides accurate and reliable sensing and switching in a single device. It provides fast, positive response and excellent repeatability with 1 amp switching capability at 48 VDC over its operating temperature range of 40°C to 120°C (104°F to 248°F). The temperature is pre-set at the factory and non-adjustable in the field.

The single pole/single throw switch assembly is operated by a bimetallic element with a positive snap action available in either normally closed, open on rising temperature or normally open, close on rising temperature configurations.

The Series 6600 thermostat has been designed around the standard 8 pin N8A Dual Inline Package, making it ideally suited for use on printed circuit boards. Its size and shape conserves space on crowded P.C. boards and can be installed using auto-insertion equipment. The device is sealed to withstand wave soldering and board washing operations.

Typical uses include turning on an indicator light, sounding an audible alarm, switching on or changing the speed of a fan, switching on a control circuit to send a message to a display screen or even switching a circuit to shut down a system upon sensing over temperature.

Applications include computers and computer peripherals, aircraft, automotive, and test equipment.

Specifications:

Contact Resistance: 50 Milliohms max. (before and after rated life)

Contact Ratings:

Approved per VDE 0631/12.83

0.02 A	5 VDC Test Class II	100,000 oper.
1 A	48 VDC Test Class I	30,000 oper.
1 A	120 VAC Test Class I	30,000 oper.

CSA Certified LR25561
UL Recognized E36687

0.001 A	5 VDC	100,000 oper.
0.02 A	5 VDC	100,000 oper.
1 A	48 VDC	30,000 oper.
1 A	120 VAC	30,000 oper.

Ambient Temperature Range:

-55°C to 160°C

Contact Operations: Either open on rise or close on rise

Operating Temperature Range:

40°C (104°F) to 120°C (248°F)

Standard Operating Temperature

Tolerance: ±5°C (±9°F) Nominal operating temperature settings in 5°C (9°F) increments

Short Term Exposure Limit:

260°C (500°F), 10 sec.

Standard 8 pin D.I.P. Configuration

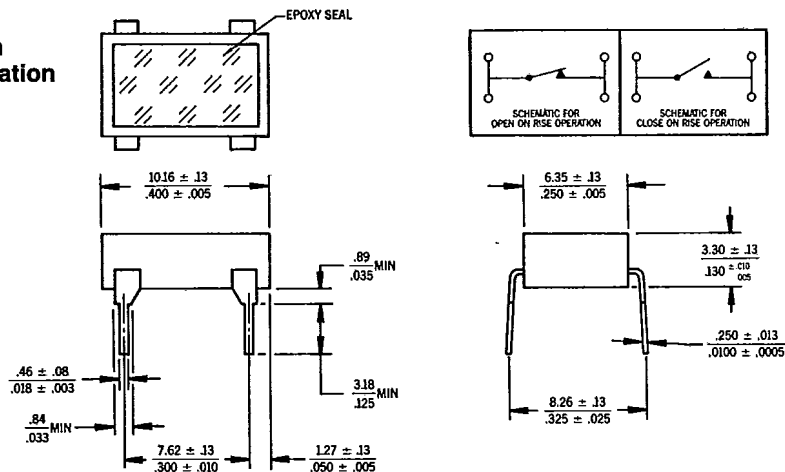

Surface Mount Configuration

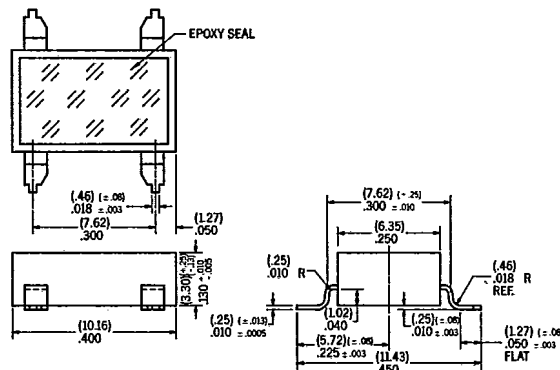

Series 6600 Thermostats

Long Term Exposure Limit:

-55°C (-67°F) to 160°C (320°F)

Dielectric Strength: 500 VAC 60 Hz
1 minute or 1800 VAC 60 Hz 1 second,
terminals to case.

Insulation Resistance: 100 Megohms
at 500 VDC

Contact Bounce - make: 3 ms max.

Weight: Approximately 0.45 grams

Seal: Non-hermetic moisture proof per
Airpax Spec. S-722 (unit will not leak while
submerged in 9" of water for a minimum of
two minutes).

Chemical Resistance: Both the base and
epoxy are resistant to water, salt, alcohol,
ammonia, trichlorethane, and most other
organic solvents.

Vibration: Per Mil-Std-202, Method 204D,
Test Condition D, 10-2,000 Hz

Shock: Per Mil-Std-202, Method 213, Test
Condition C, 100 G's, 6 milliseconds,
½ sine wave

Solderability: Per Mil-Std-202F,
Method 208D

Resistance to Soldering Heat: Per Mil-
Std-202F, Method 210A, Test Condition E

Mechanical Life: 1KK operations.

Materials:

Seal: High temperature epoxy

Base: Ryton, 94 V0 rated

Terminals: Copper Nickel Zinc Alloy

Contacts: Gold-plated Silver cross bar

6600 SERIES STANDARD CALIBRATIONS

OPERATE (± 5°C)	RESET (MIN °C)	DIFFERENTIAL (MIN °C)
40	20	4
45	20	4
50	30	4
55	30	4
60	40	4
65	40	4
70	50	4
75	50	4
80	55	6
85	55	6
90	60	6
95	60	6
100	70	6
105	70	6
110	80	6

How to use this chart

Each thermostat Part Number consists of functional "building blocks" to enable the user to specify clearly and precisely the desired characteristics in each category. Select the proper Code in each category, then transfer it to the box indicated. Unless a special requirement is indicated, the Part Number will be complete when the proper temperature is selected. If you have a special requirement, please call Airpax for a factory assigned number to complete the Part Number.

Example: A 66F060 thermostat will close (make contact) on a rising temperature from 55°C to 65°C and will reset (break contact) on a falling temperature no less than 4°C lower than the actual close temperature and no lower than 40°C actual temperature.

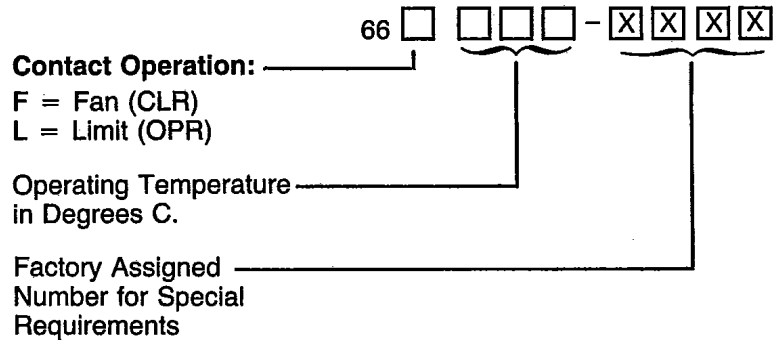

TEMPERATURE CONVERSION TABLE

If center column value is °F, the °C equivalent is to the left. If center column value is °C, the °F equivalent is to the right.

°C.	°F.	°C.	°F.	°C.	°F.	°C.	°F.	°C.	°F.	°C.	°F.	°C.	°F.	
-34.44	-30	-22	15.56	60	140	65.56	150	302	115.56	240	464	165.56	330	626
-33.89	-29	-20.2	16.11	61	141.8	66.11	151	303.8	116.11	241	465.8	166.11	331	627.8
-33.33	-28	-18.4	16.67	62	143.6	66.67	152	305.6	116.67	242	467.6	166.67	332	629.6
-32.78	-27	-16.6	17.22	63	145.4	67.22	153	307.4	117.22	243	469.4	167.22	333	631.4
-32.22	-26	-14.8	17.78	64	147.2	67.78	154	309.2	117.78	244	471.2	167.78	334	633.2
-31.67	-25	-13	18.33	65	149	68.33	155	311	118.33	245	473	168.33	335	635
-31.11	-24	-11.2	18.89	66	150.8	68.89	156	312.8	118.89	246	474.8	168.89	336	636.8
-30.56	-23	-9.4	19.44	67	152.6	69.44	157	314.6	119.44	247	476.6	169.44	337	638.6
-30	-22	-7.6	19.99	68	154.4	70	158	316.4	120	248	478.4	170	338	640.4
-29.44	-21	-5.8	20.56	69	156.2	70.56	159	318.2	120.56	249	480.2	170.56	339	642.2
-28.89	-20	-4	21.11	70	158	71.11	160	320	121.11	250	482	171.11	340	644
-28.33	-19	-2.2	21.67	71	159.8	71.67	161	321.8	121.67	251	483.8	171.67	341	645.8
-27.78	-18	-0.4	22.22	72	161.6	72.22	162	323.6	122.22	252	485.6	172.22	342	647.6
-27.22	-17	-1.4	22.78	73	163.4	72.78	163	325.4	122.78	253	487.4	172.78	343	649.4
-26.67	-16	-3.2	23.33	74	165.2	73.33	164	327.2	123.33	254	489.2	173.33	344	651.2
-26.11	-15	-5	23.89	75	167	73.89	165	329	123.89	255	491	173.89	345	653
-25.56	-14	-6.8	24.44	76	168.8	74.44	166	330.8	124.44	256	492.8	174.44	346	654.8
-25	-13	-8.6	25	77	170.6	75	167	332.6	125	257	494.6	175	347	656.6
-24.44	-12	-10.4	25.56	78	172.4	75.56	168	334.4	125.56	258	496.4	175.56	348	658.4
-23.89	-11	-12.2	26.11	79	174.2	76.11	169	336.2	126.11	259	498.2	176.11	349	660.2
-23.33	-10	-14	26.67	80	176	76.67	170	338	126.67	260	500	176.67	350	662
-22.78	-9	-15.8	27.22	81	177.8	77.22	171	339.8	127.22	261	501.8	177.22	351	663.8
-22.22	-8	-17.6	27.78	82	179.6	77.78	172	341.6	127.78	262	503.6	177.78	352	665.6
-21.67	-7	-19.4	28.33	83	181.4	78.33	173	343.4	128.33	263	505.4	178.33	353	667.4
-21.11	-6	-21.2	28.89	84	183.2	78.89	174	345.2	128.89	264	507.2	178.89	354	669.2
-20.56	-5	-23	29.44	85	185	79.44	175	347	129.44	265	509	179.44	355	671
-20	-4	-24.8	30	86	186.8	80	176	348.8	130	266	510.8	180	356	672.8
-19.44	-3	-26.6	30.56	87	188.6	80.56	177	350.6	130.56	267	512.6	180.56	357	674.6
-18.89	-2	-28.4	31.11	88	190.4	81.11	178	352.4	131.11	268	514.4	181.11	358	676.4
-18.33	-1	-30.2	31.67	89	192.2	81.67	179	354.2	131.67	269	516.2	181.67	359	678.2
-17.78	0	-32	32.22	90	194	82.22	180	356	132.22	270	518	182.22	360	680
-17.22	1	-33.8	32.78	91	195.8	82.78	181	357.8	132.78	271	519.8	182.78	361	681.8
-16.67	2	-35.6	33.33	92	197.6	83.33	182	359.6	133.33	272	521.6	183.33	362	683.6
-16.11	3	-37.4	33.89	93	199.4	83.89	183	361.4	133.89	273	523.4	183.89	363	685.4
-15.56	4	-39.2	34.44	94	201.2	84.44	184	363.2	134.44	274	525.2	184.44	364	687.2
-15	5	-41	35	95	203	85	185	365	135	275	527	185	365	689
-14.44	6	-42.8	35.56	96	204.8	85.56	186	366.8	135.56	276	528.8	185.56	366	690.8
-13.89	7	-44.6	36.11	97	206.6	86.11	187	368.6	136.11	277	530.6	186.11	367	692.6
-13.33	8	-46.4	36.67	98	208.4	86.67	188	370.4	136.67	278	532.4	186.67	368	694.4
-12.78	9	-48.2	37.22	99	210.2	87.22	189	372.2	137.22	279	534.2	187.22	369	696.2
-12.22	10	-50	37.78	100	212	87.78	190	374	137.78	280	536	187.78	370	698
-11.67	11	-51.8	38.33	101	213.8	88.33	191	375.8	138.33	281	537.8	188.33	371	699.8
-11.11	12	-53.6	38.89	102	215.6	88.89	192	377.6	138.89	282	539.6	188.89	372	701.6
-10.56	13	-55.4	39.44	103	217.4	89.44	193	379.4	139.44	283	541.4	189.44	373	703.4
-10	14	-57.2	40	104	219.2	90	194	381.2	140	284	543.2	190	374	705.2
-9.44	15	-59	40.56	105	221	90.56	195	383	140.56	285	545	190.56	375	707
-8.89	16	-60.8	41.11	106	222.8	91.11	196	384.8	141.11	286	546.8	191.11	376	708.8
-8.33	17	-62.6	41.67	107	224.6	91.67	197	386.6	141.67	287	548.6	191.67	377	710.6
-7.78	18	-64.4	42.22	108	226.4	92.22	198	388.4	142.22	288	550.4	192.22	378	712.4
-7.22	19	-66.2	42.78	109	228.2	92.78	199	390.2	142.78	289	552.2	192.78	379	714.2
-6.67	20	-68	43.33	110	230	93.33	200	392	143.33	290	554	193.33	380	716
-6.11	21	-69.8	43.89	111	231.8	93.89	201	393.8	143.89	291	555.8	193.89	381	717.8
-5.56	22	-71.6	44.44	112	233.6	94.44	202	395.6	144.44	292	557.6	194.44	382	719.6
-5	23	-73.4	45	113	235.4	95	203	397.4	145	293	559.4	195	383	721.4
-4.44	24	-75.2	45.56	114	237.2	95.56	204	399.2	145.56	294	561.2	195.56	384	723.2
-3.89	25	-77	46.11	115	239	96.11	205	401	146.11	295	563	196.11	385	725
-3.33	26	-78.8	46.67	116	240.8	96.67	206	402.8	146.67	296	564.8	196.67	386	726.8
-2.78	27	-80.6	47.22	117	242.6	97.22	207	404.6	147.22	297	566.6	197.22	387	728.6
-2.22	28	-82.4	47.78	118	244.4	97.78	208	406.4	147.78	298	568.4	197.78	388	730.4
-1.67	29	-84.2	48.33	119	246.2	98.33	209	408.2	148.33	299	570.2	198.33	389	732.2
-1.11	30	-86	48.89	120	248	98.89	210	410	148.89	300	572	198.89	390	734
-0.56	31	-87.8	49.44	121	249.8	99.44	211	411.8	149.44	301	573.8	199.44	391	735.8
0	32	-89.6	50	122	251.6	100	212	413.6	150	302	575.6	200	392	737.6
.56	33	-91.4	50.56	123	253.4	100.56	213	415.4	150.56	303	577.4	200.56	393	739.4
1.11	34	-93.2	51.11	124	255.2	101.11	214	417.2	151.11	304	579.2	201.11	394	741.2
1.67	35	-95	51.67	125	257	101.67	215	419	151.67	305	581	201.67	395	743
2.22	36	-96.8	52.22	126	258.8	102.22	216	420.8	152.22	306	582.8	202.22	396	744.8
2.78	37	-98.6	52.78	127	260.6	102.78	217	422.6	152.78	307	584.6	202.78	397	746.6
3.33	38	-100.4	53.33	128	262.4	103.33	218	424.4	153.33	308	586.4	203.33	398	748.4
3.89	39	-102.2	53.89	129	264.2	103.89	219	426.2	153.89	309	588.2	203.89	399	750.2
4.44	40	-104	54.44	130	266	104.44	220	428	154.44	310	590	204.44	400	752
5	41	-105.8	55	131	267.8	105	221	429.8	155	311	591.8	205	401	753.8
5.56	42	-107.6	55.56	132	269.6	105.56	222	431.6	155.56	312	593.6	205.56	402	755.6
6.11	43	-109.4	56.11	133	271.4	106.11	223	433.4	156.11	313	595.4	206.11	403	757.4
6.67	44	-111.2	56.67	134	273.2	106.67	224	435.2	156.67	314	597.2	206.67	404	759.2
7.22	45	-113	57.22	135	275	107.22	225	437	157.22	315	599	207.22	405	761
7.78	46	-114.8	57.78	136	276.8	107.78	226	438.8	157.78	316	600.8	207.78	406	762.8
8.33	47	-116.6	58.33	137	278.6	108.33	227	440.6	158.33	317	602.6	208.33	407	764.6
8.89	48	-118.4	58.89	138	280.4	108.89	228	442.4	158.89	318	604.4	208.89	408	766.4
9.44	49	-120.2	59.44	139	282.2	109.44	229	444.2	159.44	319	606.2	209.44	409	768.2
10	50	-122	60	140	284	110	230	446	160	320	608	210	410	770
10.56	51	-123.8	60.56	141	285.8	110.56	231	447.8	160.56	321	609.8	210.56	411	771.8
11.11	52	-125.6	61.11	142	287.6	111.11	232	449.6	161.11	322	611.6	211.11	412	773.6
11.67	53	-127.4	61.67	143	289.4	111.67	233	451.4	161.67	323	613.4	211.67	413	775.4
12.22	54	-129.2	62.22	144	291.2	112.22	234	453.2	162.22	324	615.2	212.22	414	777.2
12.78	55	-131	62.78	145	293	112.78	235	455	162.78	325	617	212.78	415	779
13.33	5													