

## The FET Constant-Current Source/Limiter

### Introduction

The combination of low associated operating voltage and high output impedance makes the FET attractive as a constant-current source. An adjustable-current source (Figure 1) may be built with a FET, a variable resistor, and a small battery. For optimum thermal stability, the FET should be biased near the zero temperature coefficient point.

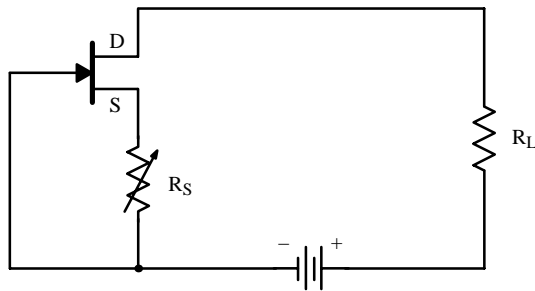

**Figure 1.** Field-Effect Transistor Current Source

NO TAG

Whenever the FET is operated in the current saturated region, its output conductance is very low. This occurs whenever the drain-source voltage  $V_{DS}$  is at least 50% greater than the cut-off voltage  $V_{GS(off)}$ . The FET may be biased to operate as a constant-current source at any current below its saturation current  $I_{DSS}$ .

### Basic Source Biasing

For a given device where  $I_{DSS}$  and  $V_{GS(off)}$  are known, the approximate  $V_{GS}$  required for a given  $I_D$  is

$$V_{GS} = V_{GS(off)} \left[ 1 - \left( \frac{I_D}{I_{DSS}} \right)^{1/k} \right] \quad (1)$$

where  $k$  can vary from 1.8 to 2.0, depending on device geometry. If  $K = 2.0$ , the series resistor  $R_S$  required between source and gate is

$$R_S = \frac{V_{GS}}{I_D} \quad \text{or} \quad R_S = \frac{V_{GS(off)}}{I_D} \left( 1 - \sqrt{\frac{I_D}{I_{DSS}}} \right) \quad (2)$$

A change in supply voltage or a change in load impedance, will change  $I_D$  by only a small factor because of the low output conductance  $g_{oss}$ .

$$\Delta I_D = (\Delta V_{DS})(g_{oss}) \quad (3)$$

The value of  $g_{oss}$  is an important consideration in the accuracy of a constant-current source where the supply voltage may vary. As  $g_{oss}$  may range from less than  $1 \mu S$  to more than  $50 \mu S$  according to the FET type, the dynamic impedance can be greater than  $1 M\Omega$  to less than  $20 k\Omega$ . This corresponds to a current stability range of  $1 \mu A$  to  $50 \mu A$  per volt. The value of  $g_{oss}$  also depends on the operating point. Output conductance  $g_{oss}$  decrease approximately linearly with  $I_D$ . The relationship is

$$\frac{I_D}{I_{DSS}} = \frac{g_{oss}}{g'_{oss}} \quad (4)$$

$$\text{where } g_{oss} = g'_{oss} \quad (5)$$

$$\text{when } V_{GS} = 0 \quad (6)$$

So as  $V_{GS} \rightarrow V_{GS(off)}$ ,  $g_{oss} \rightarrow \text{Zero}$ . For best regulation,  $I_D$  must be considerably less than  $I_{DSS}$ .

### Cascading for Low $g_{oss}$

It is possible to achieve much lower  $g_{oss}$  per unit  $I_D$  by cascading two FETs, as shown in Figure 2.

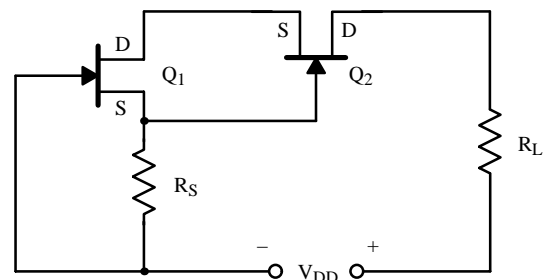

**Figure 2.** Cascade FET Current Source

Updates to this app note may be obtained via facsimile by calling Siliconix FaxBack, 1-408-970-5600. Please request FaxBack document #70596.

# AN103

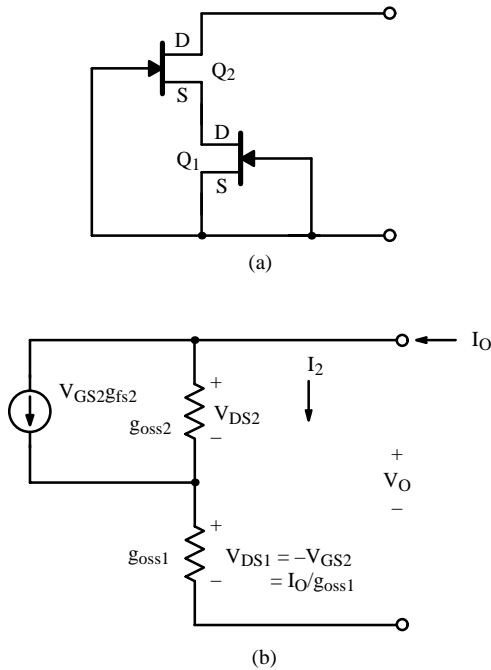

**Figure 3.** Cascade FET  $V_{GS1} = 0$

Now,  $I_D$  is regulated by  $Q_1$  and  $V_{DS1} = -V_{GS2}$ . The dc value of  $I_D$  is controlled by  $R_S$  and  $Q_1$ . However,  $Q_1$  and  $Q_2$  both affect current stability. The circuit output conductance is derived as follows:

$$\text{If } g_{oss1} = g_{oss2} \quad (7)$$

$$g_o = \frac{g_{oss}}{2 + \frac{g_{fs}}{g_{oss}}} \quad (8)$$

when  $R_S \neq 0$  as in Figure 2

$$g_o \approx \frac{g_{oss}^2}{g_{fs}(1 + R_S g_{fs})} \quad (9)$$

In either case ( $R_S = 0$  or  $R_S \neq 0$ ), the circuit output conductance is considerably lower than the  $g_{oss}$  of a single FET.

In designing any cascaded FET current source, both FETs must be operated with adequate drain-gate voltage,  $V_{DG}$ . That is,

$$V_{DG} > V_{GS(off)}, \text{ preferably } V_{DG} > 2V_{GS(off)} \quad (10)$$

If  $V_{DG} < 2 V_{GS(off)}$ , the  $g_{oss}$  will be significantly increased, and circuit  $g_o$  will deteriorate. For example: A

JFET may have a typical  $g_{oss} = 4 \mu S$  at  $V_{DS} = 20 V$  and  $V_{GS} = 0$ . At  $V_{DS} \sim -V_{GS(off)} = 2 V$ ,  $g_{oss} \sim 100 \mu S$ .

The best FETs for current sources are those having long gates and consequently very low  $g_{oss}$ . The Siliconix 2N4340, J202, and SST202 exhibit typical  $g_{oss} = 2 \mu S$  at  $V_{DS} = 20 V$ . These devices in the circuit of Figure 4 will provide a current source adjustable from  $5 \mu A$  to  $0.8 mA$  with internal impedance greater than  $2 M\Omega$  at  $0.2 mA$ . Other Siliconix part types such as the 2N4392, J112, and SST112 can provide  $10 mA$  or higher current.

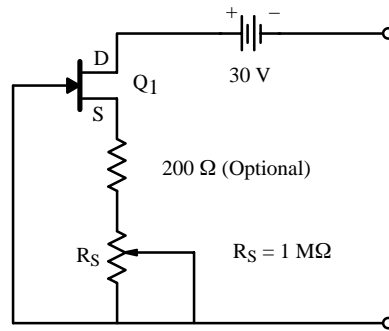

**Figure 4.** Adjustable Current Source  $R_S = 1 M\Omega$

Instead of the adjustable resistor, the JFETs can be put in  $I_{DSS}$  range groupings with an appropriate  $R_S$  resistor selected for each group. This method is common in high volume applications.

The cascade circuit of Figure 5 provides a current adjustable from  $2 \mu A$  to  $0.8 mA$  with internal resistance greater than  $10 M\Omega$ .

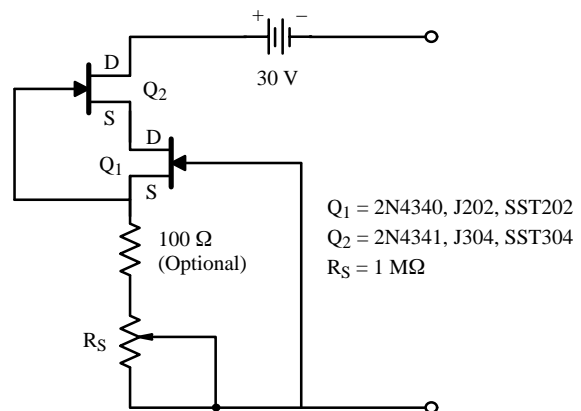

**Figure 5.** Cascade FET Current Source

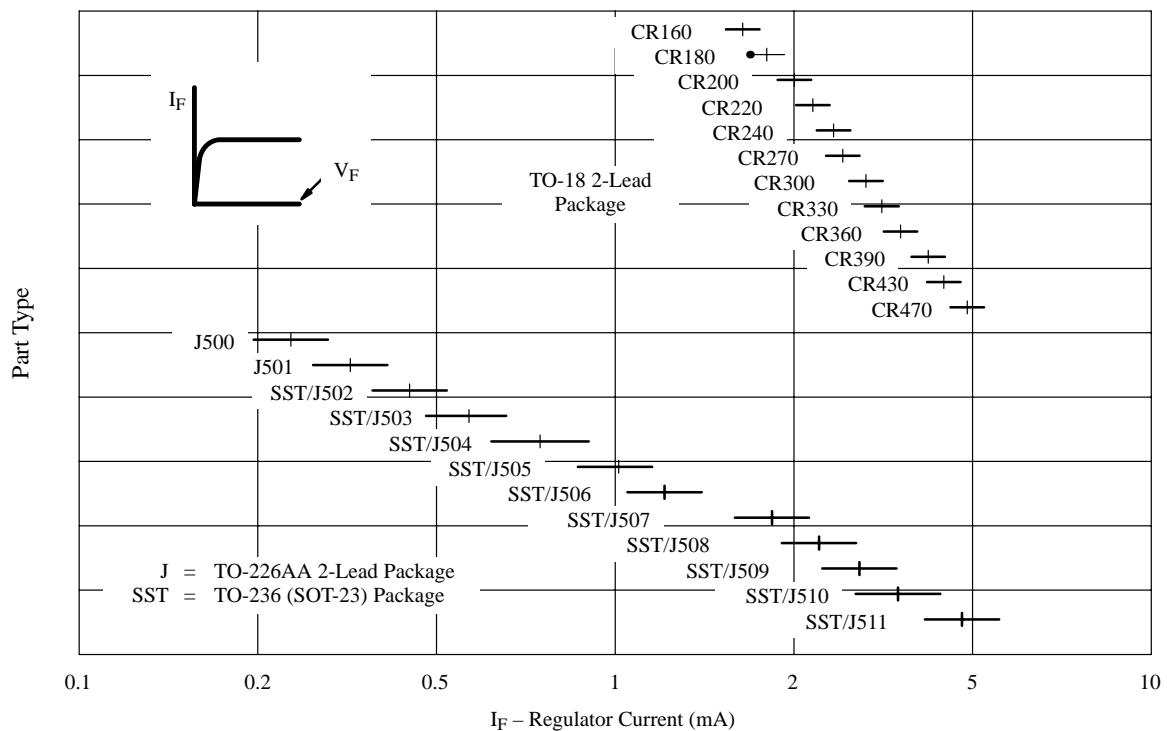

**Figure 6.** Standard Series Current Regulator Range

## Standard Two-Leaded Devices

Siliconix offers a special series of two-leaded JFETs with a resistor fabricated on the device, thus creating a  $\pm 10\%$  current range. Devices are available in ranges from 1.6 mA (CR160) to 4.7 mA (CR470).

For designs requiring a  $\pm 20\%$  current range, Siliconix offers devices rated from 0.24 mA typical (J500) through 4.7 mA typical (J511) in a two-leaded TO-226A (TO-92) package. The SST502 series is available in surface mount TO-236 (SOT-23).

Each of these two-leaded devices can be used to replace several typical components.

Figure 6 shows the current ranges of these two device series. Further information is contained in the individual data sheets appearing elsewhere in this data book or from Siliconix FaxBack.

The CR160 series features guaranteed peak operating voltage minimum of 100 V with a typical of 180 V. The J500 series features 50 V minimum with a typical of 100 V. The lower current devices in both series provide excellent current regulation down to as little as 1 V.

## Bias Resistor Selection

All industry JFET part types exhibit a significant variation in  $I_{DSS}$  and  $V_{GS(off)}$  on min/max specifications and device-to-device variations.

Using the simple source biasing current source as illustrated in Figure 1, the designer can graphically calculate the  $R_S$  which best fits the desired drain current  $I_D$ . Figure 7 plotting  $I_D$  versus  $V_{GS}$  over the military temperature range shows the resulting  $I_D$  for different values of  $R_S$ .

The  $R_S$  lines are constructed by drawing the slope of the  $R_S$  desired value starting at the origin, eg.  $R_S = 2$  k slope. Find a convenient point on the X - Y axis to mark a

$\frac{V_{GS}}{I_D}$  of 2 k $\Omega$  such as  $V_{GS} = -1.5$  V and  $I_D = 0.75$  mA.

Then, draw a straight line from this point to the origin. The intersection of this  $R_S$  line and the device  $I_D$  versus  $V_{GS}$  will be the operating  $I_D$ . In this example, the resulting  $I_D = 0.35$  mA at  $T_J = 25^\circ\text{C}$ . The intercepts of the  $T_J = -55^\circ\text{C}$  and  $125^\circ\text{C}$  show the minimal variation with temperature.

Also note that JFETs have a  $I_D$  current where there is no change with temperature variation. To achieve this  $0T_C$ , the  $-V_{GS}$  voltage ( $I_D \times R_S$ ) is approximately:

$$V_{GS(0T_C)} \approx V_{GS(off)} - 0.65 \text{ V} \quad (11)$$

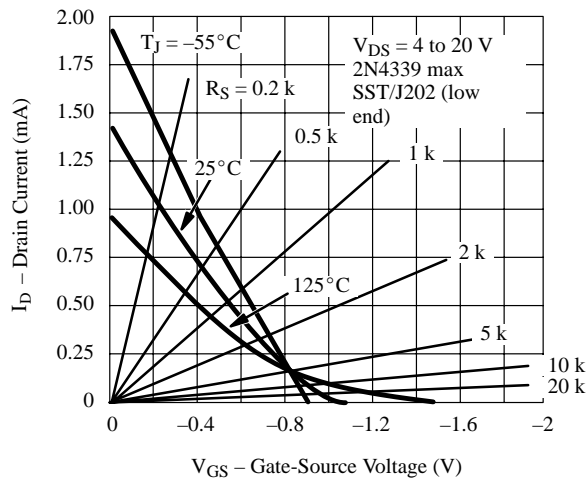

**Figure 7.** JFET Typical Transfer Characteristic

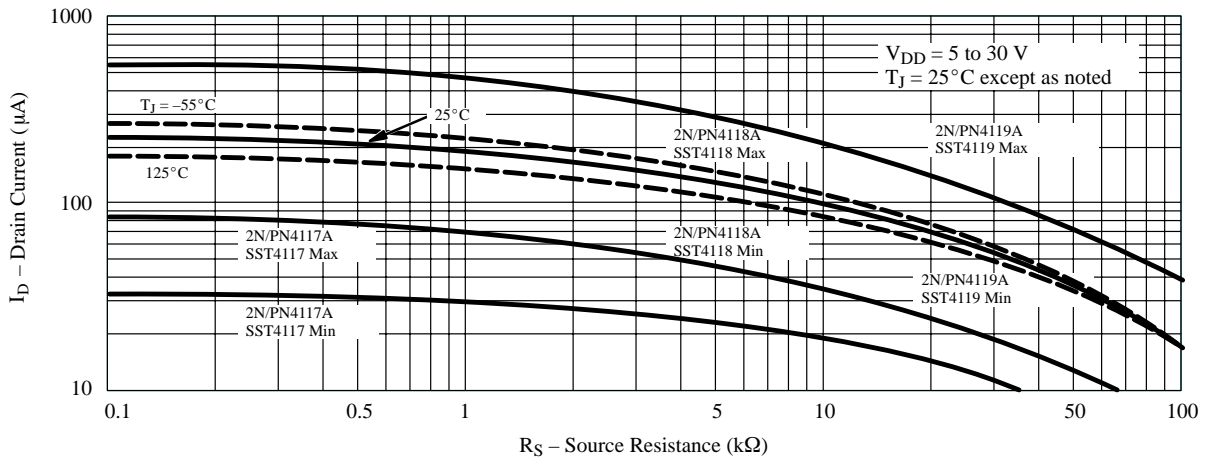

**Figure 8.** Source Biased Drain-Current vs. Source Resistance

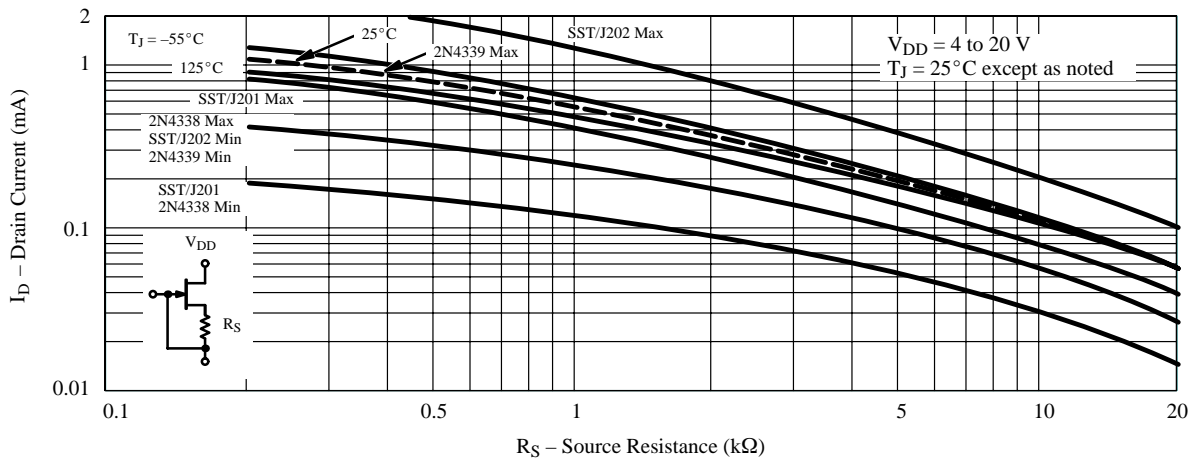

**Figure 9.** JFET Source Biased Drain-Current vs. Source Resistance

## Choosing the Correct JFET for Source Biasing

Each of the Siliconix device data sheets include typical transfer curves that can be used as illustrated in Figure 7.

Several popular devices are ideal for source biased current sources covering a few  $\mu\text{As}$  to 20 mA. To aid the designer, the devices in Table 1 have been plotted to show the drain current,  $I_D$ , versus the source resistance,  $R_S$ , in Figures 8, 9, and 10. Most plots include the likely worst case  $I_D$  variations for a particular  $R_S$ . For tighter current control, the JFET production lot can be divided into ranges with an appropriate resistor selection for each range.

Table 1: Source Biasing Device Recommendations

Practical Current Range $I_D$ (mA)	Through-Hole Plastic Device	Surface Mount Device	Metal Can Device
0.01 – 0.02	PN4117A	SST4117	2N4117A
0.01 – 0.04	PN4118A	SST4118	2N4118A
0.02 – 0.1	PN4119A	SST4119	2N4119A
0.01 – 0.1	J201	SST201	2N4338
0.02 – 0.3	J202	SST202	2N4339
0.1 – 2	J113	SST113	2N4393
0.2 – 10	J112	SST112	2N4392

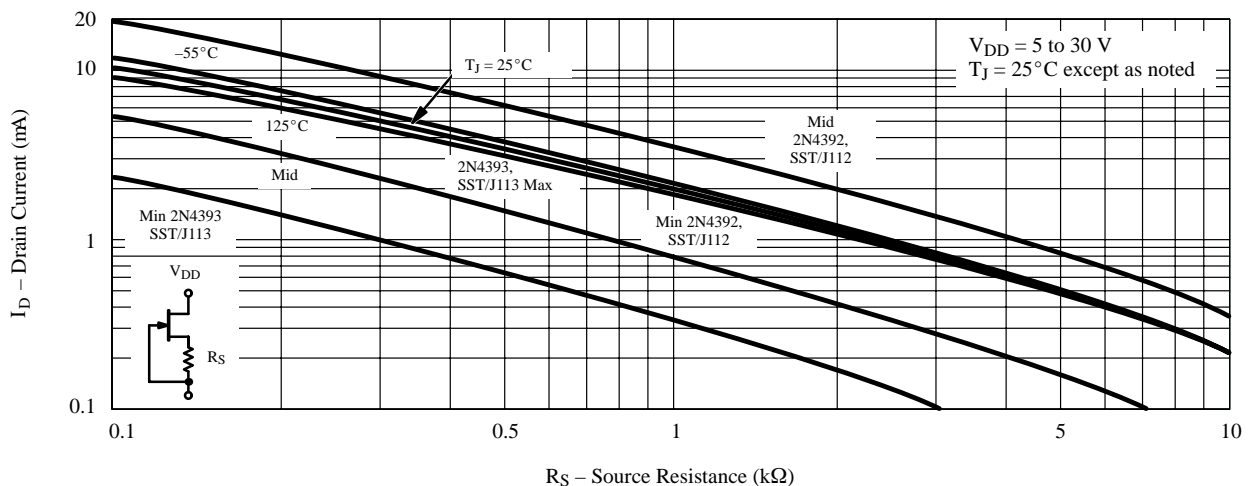

Figure 10. JFET Source Biased Drain-Current vs. Source Resistance