

### GENERAL DESCRIPTION

The RSM84510 Scrolling Mouse Controller is specially designed to control PS/2 mouse device. This single chip can interface three key-switches four photo-couples plus z-axis direct to 8042 controller.

RSM84510 can receive command and echo status or data format which are compatible with IBM PS/2 mode mouse.

Key debouncing circuit is provided to prevent false entry and improve the accuracy.

In the traditional mouse, a great number of noises are generated when the grid is partially closed or opened. These noises are usually mistaken for movement signals by traditional mouse controller and the cursor of the display screen is thus moved frequently up and down or back and forth. This will consume a great amount of energy. The RSM84510 mouse controller provides noise immunity circuits to eliminat these noise in order to reduce energy consumption.

### FEATURES

- Using  $51k \pm 5\%$  resistor for RC oscillation.
- Compatible with legacy PS/2 mouse.
- Compatible with Microsoft scrolling mouse.
- Built-in noise immunity circuit.
- Built-in current comparator for photo-couples input.
- Built-in three step dynamic input impedance.
- Three key-switches and four photo-couples inputs.
- Six types Z direction input:
 

1.Photo couples input.(Z/1)	4.Mechanical input.(Z/1)
2.Key-switches input.	5.Photo couples input.(Z/4)
3.Voltage-sensing input.	6.Mechanical input.(Z/2)
- Both key-press and key-release debounce interval 12 ms.
- The sampling rate of motion detector is about 65KHz.
- Low power dissipation.
- Package type:
 

RSM84510AP: 16DIP,Photo couples input.(Z/1)	RSM84510DP: 16DIP,Mechanical input.(Z/1)
RSM84510BP: 16DIP,Key-switches input.	RSM84510EP: 16DIP,Photo couples input.(Z/4)
RSM84510CP: 16DIP,Voltage-sensing input	RSM84510FP: 16DIP,Mechanical input.(Z/2)
- PIN to PIN compatible with RSM84510.

### PIN ASSIGNMENT

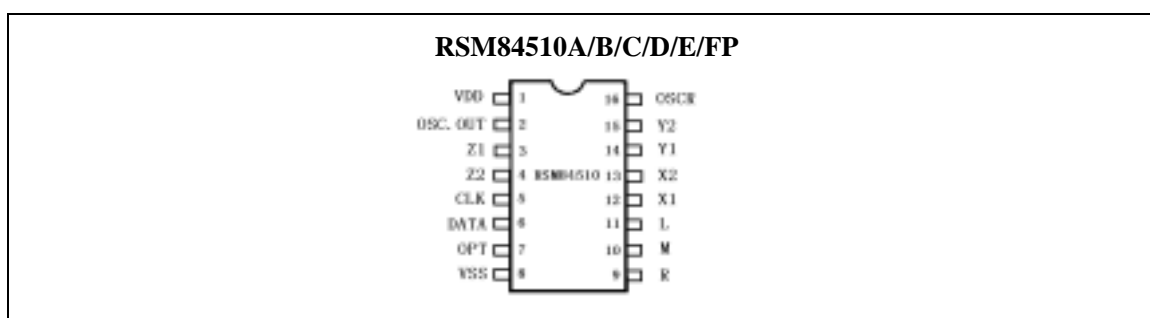

### PIN DESCRIPTIONS

Pin	Symbol	I/O	Function
7	OPT	I/O	INPUT:200kohm pull low to VSS. When OPT is connected to VDD, RSM84510 will enter test mode. In test mode, L will be the output of X1, while M will be the output of X2. Toggling R key can change these output to be Y1, Y2, or Z1, Z2 respectively. OUTPUT:2kHz Z-axis LED driving source. “ 1 ” =VDD, “ 0 ” =floating High duty is about 60us.
2	OSC.OUT	O	RC mode oscillation with 51kohm resistor.
16	OSCR	I	
5	CLK	I/O	Connect to 8042 auxiliary port CLK line.
6	DATA	I/O	Connect to 8042 auxiliary port DATA line.
9/10/11	R/M/L	I	Three key-switches inputs. 200kohm resistor pull low.
12	X1	I	Three step dynamic input impedance. Use current comparator to measure photo-couples “ ON ” ,or “ OFF ” .
13	X2		
14	Y1		
15	Y2		
3	Z1	I	Z-axis inputs. Photo mode: Three step dynamic input impedance. Current comparator input. Key mode: 200kohm resistor pull low. 7 levels increased by “ M ” key. Voltage mode: 200kohm resistor pull low. 7 levels voltage comparator. Mechanical mode: 13.2kohm resistor pull low.
4	Z2		
8	VSS		Ground
1	VDD		Power

### FUNCTIONAL BLOCK DIAGRAM

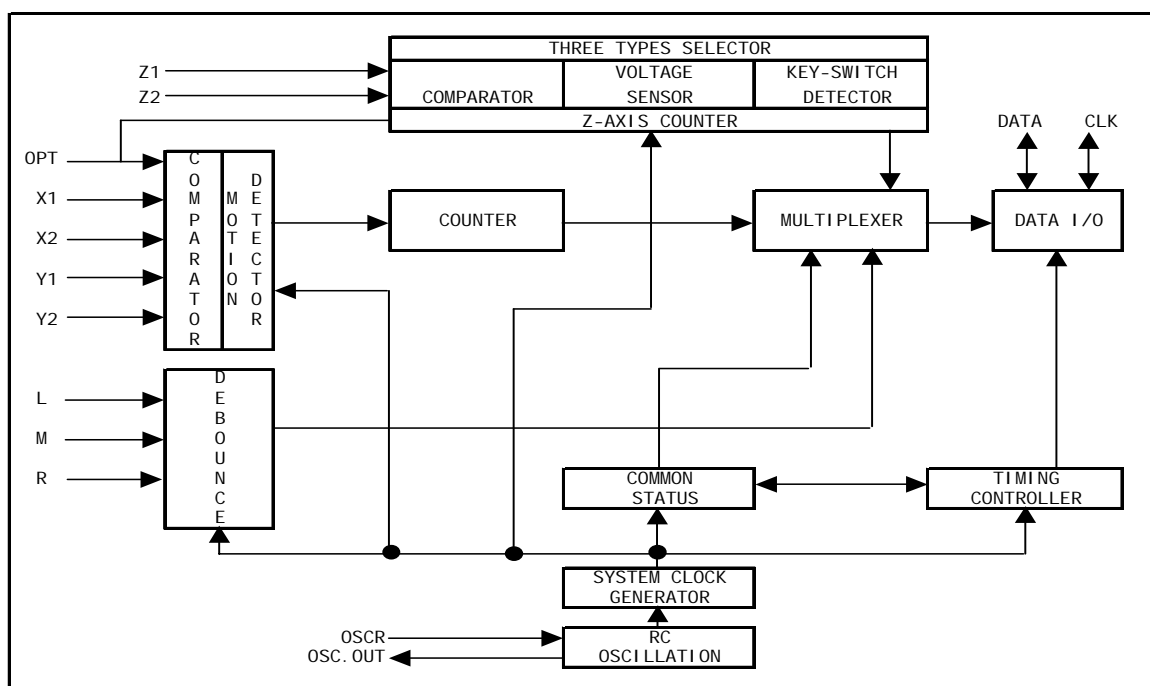

### ABSOLUTE MAXIMUM RATINGS

Parameters	Sym	Ratings	Unit
Temperature under bias	$T_{OPR}$	0~70	
Storage temperature range	$T_{STR}$	-65~150	
Input voltage	$V_{IN}$	-0.3~6.0	V
Output voltage	$V_O$	-0.3~6.0	V

### DC ELECTRICAL CHARACTERISTICS( $T_A=25$ to 70 )

Parameters	Sym.	Min.	Typ.	Max.	Unit
Operating voltage	VDD	4.5	5	5.5	V
Operating current (no load)	Iop	-	-	1.2	mA
X1,X2,Y1,Y2,Z1,Z2(photo mode) Input voltage (80 $\mu$ A)	$V_{PI}$	0.8	-	1.2	V
X1,X2,Y1,Y2,Z1,Z2(photo mode) Input voltage (500 $\mu$ A)	$V_{PI}$	1.5	-	2.8	V
CLK, DATA positive-going Threshold voltage	$V_{t+}$	$0.6V_{DD}$	-	$0.8V_{DD}$	V
CLK, DATA negative-going Threshold voltage	$V_{t-}$	$0.2V_{DD}$	-	$0.4V_{DD}$	V
L,M,R,OPT,Z1,Z2(key mode) input low voltage	$V_{ail}$	-	-	$0.3 V_{DD}$	V
L,M,R,OPT,Z1,Z2(key mode) input high voltage	$V_{aih}$	$0.7V_{DD}$	-	-	V
L,M,R,Z1,Z2(key & voltage mode) Input resistor ( $V_{in}=V_{DD}$ )	Rmi	92	-	310	K
OPT input resistor ( $V_{in}=V_{DD}$ )	$R_{xi}$	133	-	400	K
DATA, CLK input current (pull up resistor) ( $V_{in}=0V$ )	Idc	0.56	-	1.86	mA
DATA, CLK low output voltage ( $I_{prl}=-4mA$ )	$V_{prl}$	-	-	0.4	V
L,M,R,X1,X2,Y1,Y2,Z1,Z2,OPT Input leakage current ( $V_{in}=0V$ )	$i_{il}$	0	-	-1.0	$\mu$ A

\*All voltages in above table are compared with  $V_{SS}$ .

\*All parameters in above table are tested under  $V_{DD}=5V$ .

\*CLK & DATA output gates are open drains that connect to pull up resistors.

\*X1,X2,Y1,Y2 Input Impedance

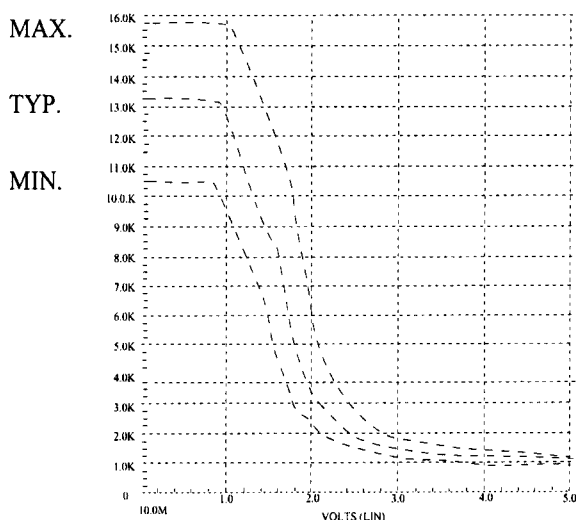

**AC ELECTRICAL CHARACTERISTICS**( $T_A = 0$  to  $70$  )

Parameters	Sym.	Min.	Typ.	Max.	Unit
Oscillating Frequency(OSCR=51K )	F <sub>osc</sub>	37.5-10%	37.5	37.5+10%	KHz
Key Debounce	T <sub>kd</sub>	-	12	-	ms
Rising Edge Crossed Width Fosc=35 KHz	T <sub>r</sub>	14.6	-	-	us
Falling Edge Crossed Width Fosc=35 KHz	T <sub>f</sub>	14.6	-	-	us
Mouse CLK Active Time	T <sub>mca</sub>	-	40	-	us
Mouse CLK Inactive Time	T <sub>mci</sub>	-	40	-	us
Mouse Sample DATA from CLK rising Edge	T <sub>mcd</sub>	-	13.3	-	us
System CLK Active Time	T <sub>sca</sub>	-	40	-	us
System CLK Inactive Time	T <sub>sci</sub>	-	40	-	us
Time from DATA Transition to Falling Edge of CLK	T <sub>sdc</sub>	-	13.3	-	us
Time from rising Edge of CLK to DATA Transition	T <sub>sdc</sub>	-	26.7	-	us
Time to mouse Inhibit after the 11th CLK to ensure mouse does not start another Transmission	T <sub>pi</sub>	0	-	50	ms

PS. The AC timings are measured under using 35 KHz system clock signal.

**FUNCTION DESCRIPTIONS**

Legacy PS/2 mouse operating:

(A) Operating mode

There are four operating modes in PS/2 mouse:

a. Reset Mode:

In this mode a self-test is initiated during power-on or by a Reset command. After reset signal, PS/2 mouse will send:

(a) Completion code AA & ID code 00.

(b) Set default :

sampling rate: 100 reports/s  
 non-autospeed  
 stream mode  
 2 dot/count  
 disable

b. Stream Mode:

The maximum rate of transfer is the programmed sample rate.

Data report is transmitted if

(a) switch is pressed

(b) movement has been detect

c. Remote Mode:

Data is transmitted only in response to a Read Data command.

d. Wrap Mode:

Any byte of data sent by the system, except hex EC ( Reset wrap mode ) or hex FF ( Reset ), is returned by RSM84510.

B). PS/2 Mouse Data Report:

i). In stream mode: A data report is sent at the end of a sample interval.

ii). In remote mode: A data report is sent in response to Read Data command.

iii). Data report format:

Byte	Bit	Description
1	0	Left button status; 1 = pressed
	1	Right button status; 1 = pressed
	2	Middle button status; 1 = pressed
	3	Reserve
	4	X data sign; 1 = negative
	5	Y data sign; 1 = negative
	6	X data overflow; 1 = overflow
	7	Y data overflow; 1 = overflow
2	0 ~ 7	X data ( D0 - D7 )
3	0 ~ 7	Y data ( D0 - D7 )

C) PS/2 mouse Data Transmission:

i). RSM84510 generates the clocking signal when sending data to and receiving data from the system.

ii). The system requests RSM84510 receive system data output by forcing the DATA line to an inactive level and allowing CLK line to go to an active level.

iii). Data transmission frame:

Bit	Function
1	Start bit ( always 0 )
2 ~ 9	Data bits ( D0 - D7 )
10	Parity bit ( odd parity )
11	Stop bit ( always 1 )

iv). Data Output ( data from RSM84510 to system ):

If CLK is low ( inhibit status ) , data is no transmission.

If CLK is high and DATA is low ( request-to-send ) , data is updated. Data is received from the system and no transmission are started by RSM84510 until CLK and DATA both high. If CLK and DATA are both high, the transmission is ready. DATA is valid prior to the falling edge of CLK and

beyond the rising edge of CLK. During transmission, RSM84510 check for line contention by checking for an inactive level on CLK at intervals not to exceed 100u sec. Contention occurs when the system lowers CLK to inhibit RSM84510 output after RSM84510 has started a transmission. If this occurs before the rising edge of the tenth clock, RSM84510 internal store its data in its buffer and returns DATA and CLK to an active level. If the contention does not occur by the tenth clock, the transmission is complete. Following a transmission, the system inhibits RSM84510 by holding CLK low until it can service the input or until the system receives a request to send a response from RSM84510.

v). Data Input ( from system to RSM84510 ):

System first check if RSM84510 is transmitting data. If RSM84510 is transmitting, the system can override the output forcing CLK to an inactive level prior to the tenth clock. If RSM84510 transmission is beyond the tenth clock, the system receives the data. If RSM84510 is not transmitting or if the system choose to override the output, the system force CLK to an inactive level for a period of not less than 100  $\mu$  sec while preparing for output. When the system is ready to output start bit (0), it allows CLK go to active level. If request-to-send is detected, RSM84510 clocks 11 bits. Following the tenth clock RSM84510 checks for an active level on the DATA line, and if found, force DATA low , and clock once more. If occurs framing error, RSM84510 continue to clock until DATA is high, then clocks the line control bit and request a Resend. When the system sends out a command or data transmission that requires a response, the system waits for RSM84510 to response before sending its next output.

D). PS/2 Mouse Error Handling:

- i). A Resend command ( FE ) following receipt of an invalid input or any input with incorrect parity.
- ii). If two invalid input are received in succession, an error code of hex FC send to the system.
- iii). The counter accumulators are cleared after receiving any command except “Resend”.
- iv). RSM84510 receives a Resend command ( FE ), it transmit its last packet of data.
- v). In the stream mode “Resend” is received by RSM84510 following a 3-byte data packet transmission to the system. RSM84510 resend the 3-byte data packet prior to clearing the counter.
- vi). A response is sent within 25 ms if
  - a). The system requires a response
  - b). An error is detected in the transmission
- vii). When a command requiring a response is issued by the system ,another command should not be

issue until either the response is received or 25ms has passed.

### E). PS/2 Mouse Commands Description:

There are 16 valid commands that transmits between the system and RSM84510. The “FA” code is always the first response to any valid input received from the system other than a Set Wrap Mode or Resend command.

The following table list the commands:

Hex Code	Command	RSM84510 echo code
FF	Reset	FA , AA , 00
FE	Resend	XX , ( XX , XX )
F6	Set Default	FA
F5	Disable	FA
F4	Enable	FA
F3,XX	Set Sampling Rate	FA , FA
F2	Read Device Type	FA , 00
F0	Set Remote Mode	FA
EE	Set Wrap Mode	FA
EC	Reset Warp Mode	FA
EB	Read Data	FA , XX , XX , XX
EA	Set Stream Mode	FA
E9	Status Request	FA , XX , XX , XX
E8,XX	Set Resolution	FA , FA
E7	Set Autospeed	FA
E6	Reset Autospeed	FA

The following describes valid commands:

#### a). Reset ( FF )

RSM84510 operation:

- i). Completion the reset.
- ii). Transmitted FA,AA,00 to the system.
- iii). Set default:
  - sampling rate: 100 reports/s
  - non-autospeed
  - stream mode
  - 2 dots/count
  - disable

#### b). Resend ( FE )

- i). Any time RSM84510 receives an invalid command, it returns a Resend command to the system.
- ii). When RSM84510 receives a Resend command, it retransmits its last packet of data. If the last packet

was a Resend command, it transmits the packet just prior to the Resend command.

iii). In stream mode, if a Resend command is received by RSM84510 immediately following a 3-byte data packet transmission to the system.

c). Set Default ( F6 )

The command reinitializes all conditions to the power-on defaults.

d). Disable ( F5 )

This command is used in the stream mode to stop transmissions from RSM84510.

e). Enable ( F4 )

Begins transmissions, if in stream mode.

f). Set Sampling Rate ( F3,XX )

In the stream mode, this command sets the sampling rate to the value indicated by byte hex XX, shown in following:

Second byte XX	Sample Rate
0A	10/sec
14	20/sec
28	40/sec
3C	60/sec
50	80/sec
64	100/sec
C8	200/sec

g). Read Device Type ( F2 )

RSM84510 always echoes " FA,00 " following this command.

h). Set Remote Mode ( F0 )

Data value are reported only in response to a Read Data command.

i). Set Wrap Mode ( EE )

Wrap mode remains until Reset ( FF ) or Reset Wrap Mode( EC ) is received.

j). Reset Wrap Mode ( EC )

RSM84510 returns to the previous mode of operation after receiving this command.

k). Read Data ( EB )

This command is executed in either remote or stream mode. The data is transmitted even if there has been no movement since the last report or the button status is unchanged. Following a Read Data command, the registers are cleared after a data transmission.



l). Set Stream Mode ( EA )

This command sets RSM84510 in stream mode.

m). Status Request ( E9 )

When this command is issued by the system, RSM84510 respond with a 3-byte status report as follows:

Byte	Bit	Description
1	0	1 = Right button pressed
	1	1 = Middle button pressed
	2	1 = Left button pressed
	3	Reserved
	4	0 = Normal speed , 1=Autospeed
	5	0=Disable , 1=Enable
	6	0 = Stream mode, 1 = Remote mode
	7	Reserved
2	0 ~ 7	Current resolution setting ( D0 - D7 )
3	0 ~ 7	Current sampling rate ( D0 - D7 )

n). Set Resolution ( E8,XX )

RSM84510 provides four resolutions selected by the second byte of this command as follows:

Second Byte XX	Resolution
00	8 dot/count
01	4 dot/count
02	2 dot/count
03	1 dot/count

o). Set Autospeed ( E7 )

At the end of a sample interval in the stream mode, the current X and Y data values are converted new values. The sign bits are not involved in this conversion. The conversion is only in stream mode. The relationship between the input and output count follows:

Input	Ouput
0	0
1	1
2	1
3	3
4	6
5	9
N( 6)	2.0*N

p). Reset Autospeed ( E6 )

This command restore normal speed.

Microsoft PS/2 scrolling mouse mode:

(A) Entering procedure: Except in WRAP mode, while RSM84510 received the following consecutive command.

- i. F3 C8 ---- set sampling rate 200/sec
- ii. F3 64 ---- set sampling rate 100/sec
- iii. F3 50 ---- set sampling rate 80/sec

(B) Operating:

- a. All of the commands in legacy mode still be valid.
- b. The ID code of read device type command (F2) will changed from "00" to be "03".
- c. Data report will be four bytes format:

Byte	Bit	Description
1	0	Left button status; 1 = pressed
	1	Right button status; 1 = pressed
	2	Middle button status; 1 = pressed
	3	Reserve
	4	X data sign; 1 = negative
	5	Y data sign; 1 = negative
	6	X data overflow; 1 = overflow
	7	Y data overflow; 1 = overflow
2	0 ~ 7	X data ( D0 - D7 )
3	0 ~ 7	Y data ( D0 - D7 )
4	0 ~ 7	Z data ( D0 - D7 )

(C) Exiting Microsoft scrolling mode:

There are two ways to exit:

- a. Power off.
- b. Reset command (FF).

Z-axis Input Function : The Z0-Z7 limit value is  $\pm 7$

(a) Photo couples input : Z-axis counter accumulates the Z1, Z2 phase changed by movement. This mode includes

noise immunity.

Z/1 : 1 dot per count.

Z/4 : 4 dots per count. Counted by Z1=1, Z2=1 phase, the wheel should stay at Z1=0, Z2=0 phase.

- (b) Key-switches input : Pressing Z1, Z2 will start to fill the Z-axis counter with the value beginning at one. Toggling "M" key can increase the value any time by one. The limit value is  $\pm 7$ .

The relationship between the value and the transmission rate as follows :

Value	Rate per second
1	2.7
2	6.4
3	9.2
4	12.8
5	15
6	18
7	20

- (c) Voltage-sensing mode : There are 7 voltage levels in Z1, Z2 input. The transmission table is the same as key-switches mode. The relationship between the value of Z-axis counter and the voltage as follows :

Value	Voltage
0	1 V
1	1.0V-1.6V
2	1.6V-2.2V
3	2.2V-2.8V
4	2.8V-3.4V
5	3.4V-4.0V
6	4.0V-4.6V
7	4.6 V

Under  $V_{DD} = 5V$  condition.

- (d) Mechanical mode : The function is the same as photo couples input mode, except there is no noise immunity.

Z/1 : 1 dot per count.

Z/2 : 2 dot per count. Counted by Z2 changing phase.

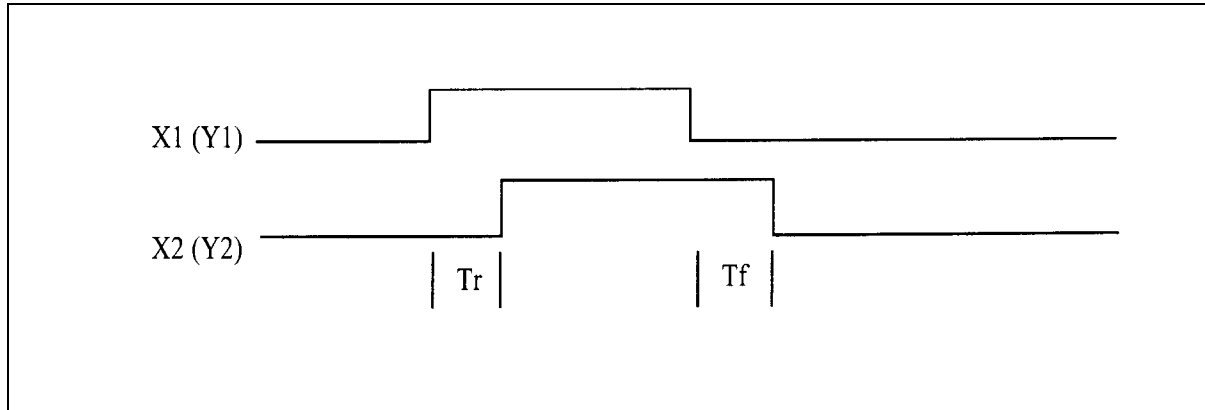
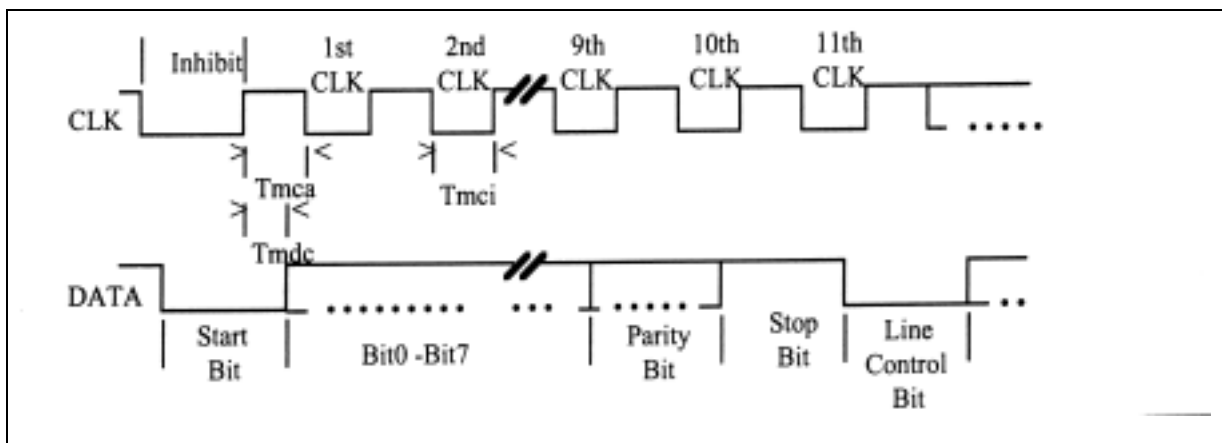
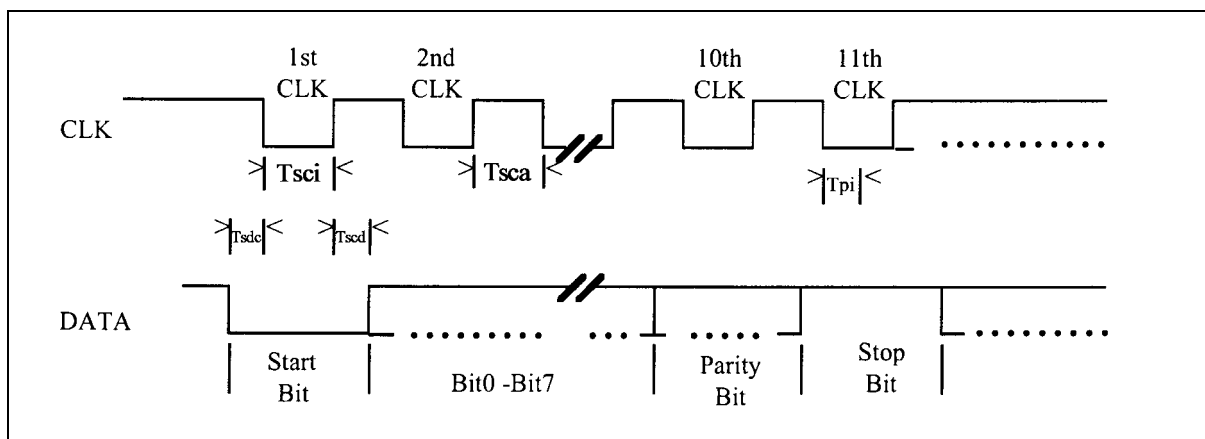
**TIMING DIAGRAM**
**(1) Photo-couples pulse width :**

**(2) PS/2 Mouse**
**(A) Receiving DATA**

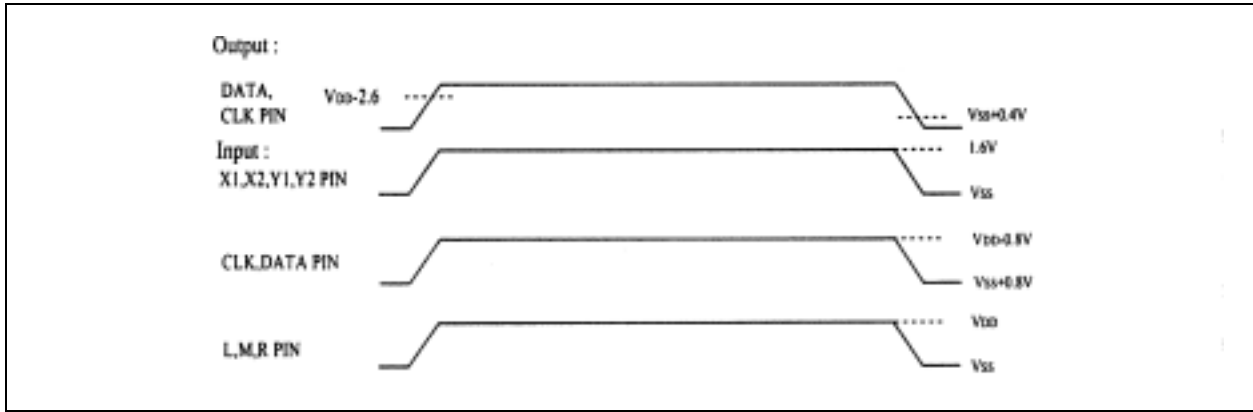
**(B) Sending DATA**

**AC Timing point:**

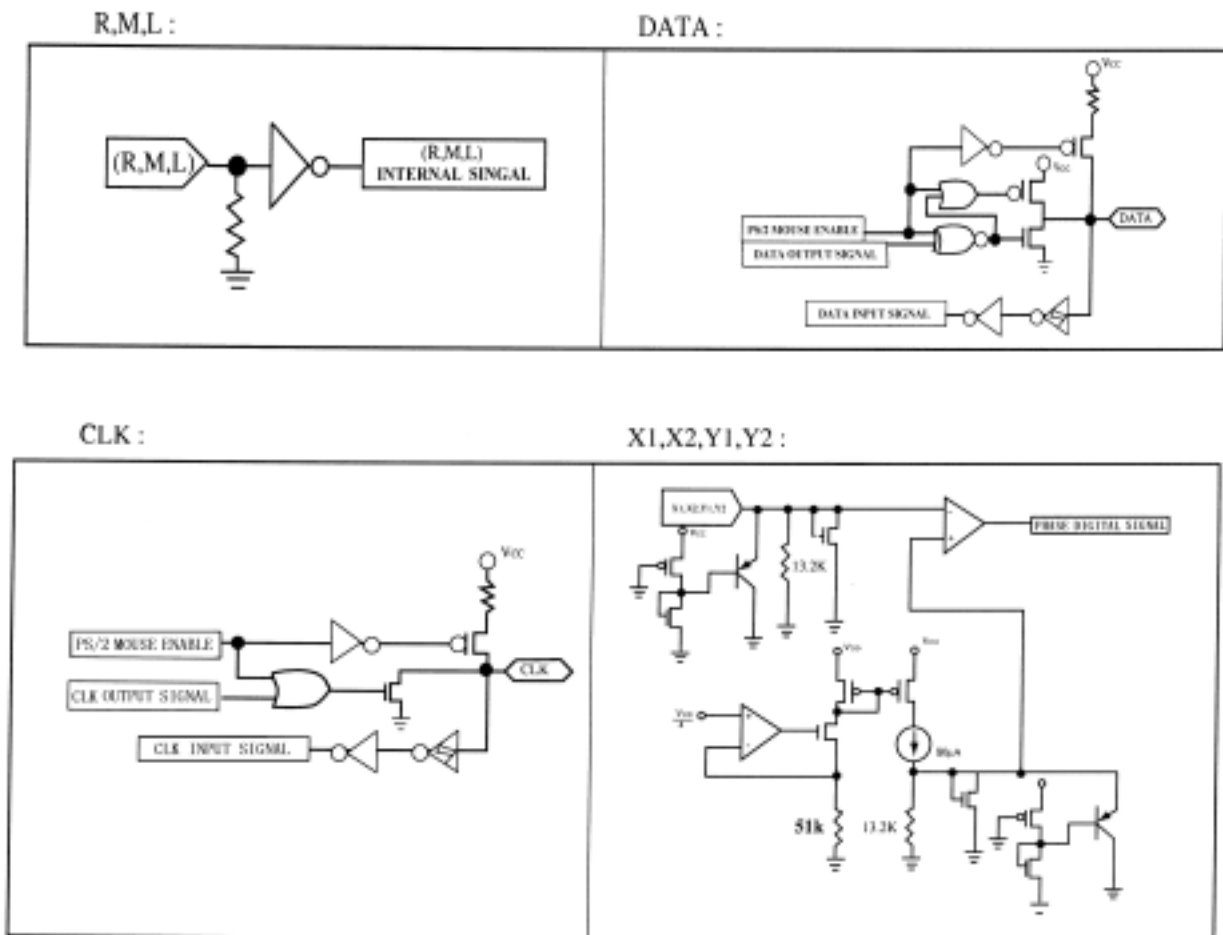

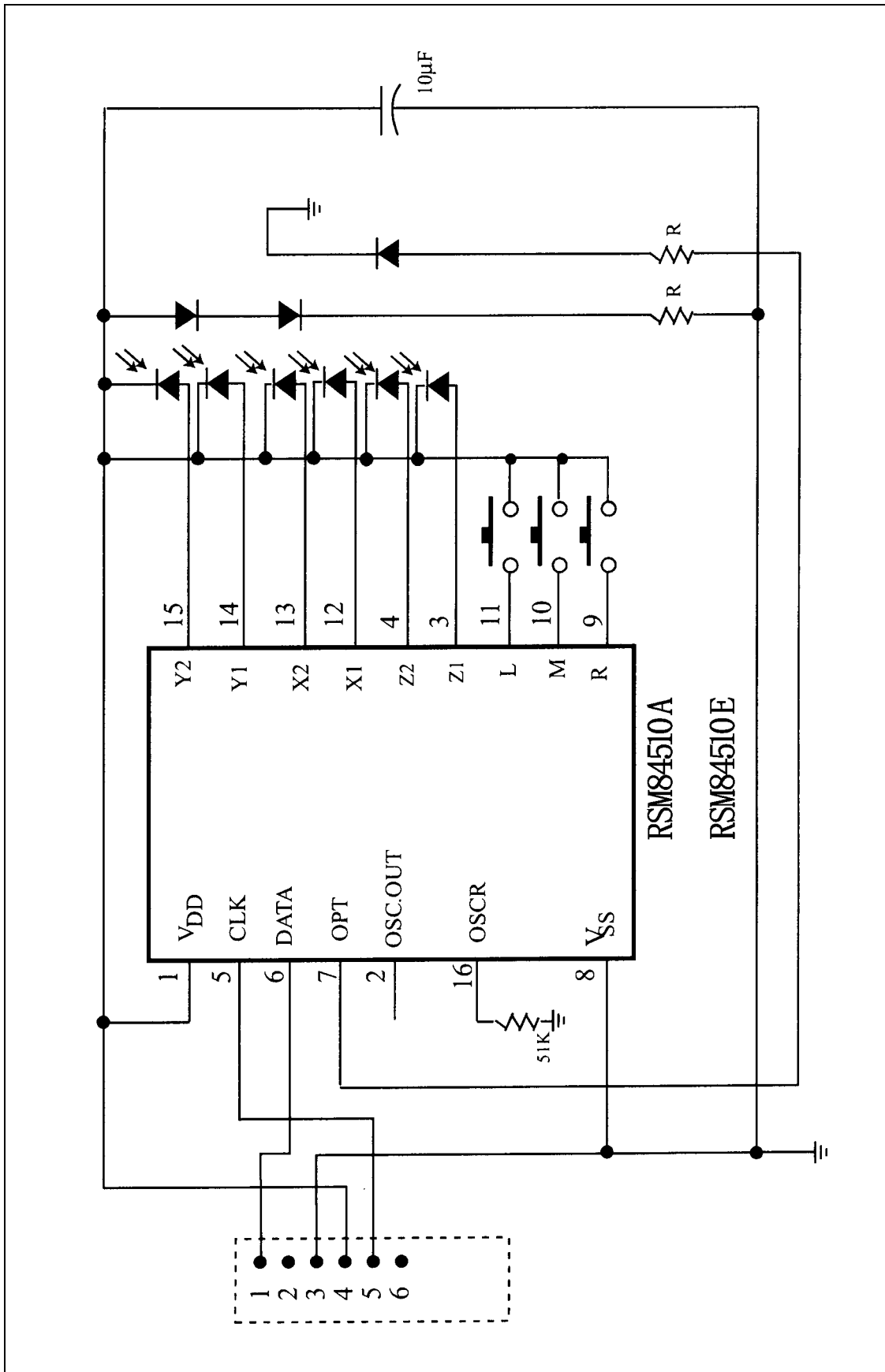
**RSM84510 I/O pin equivalent circuit :**





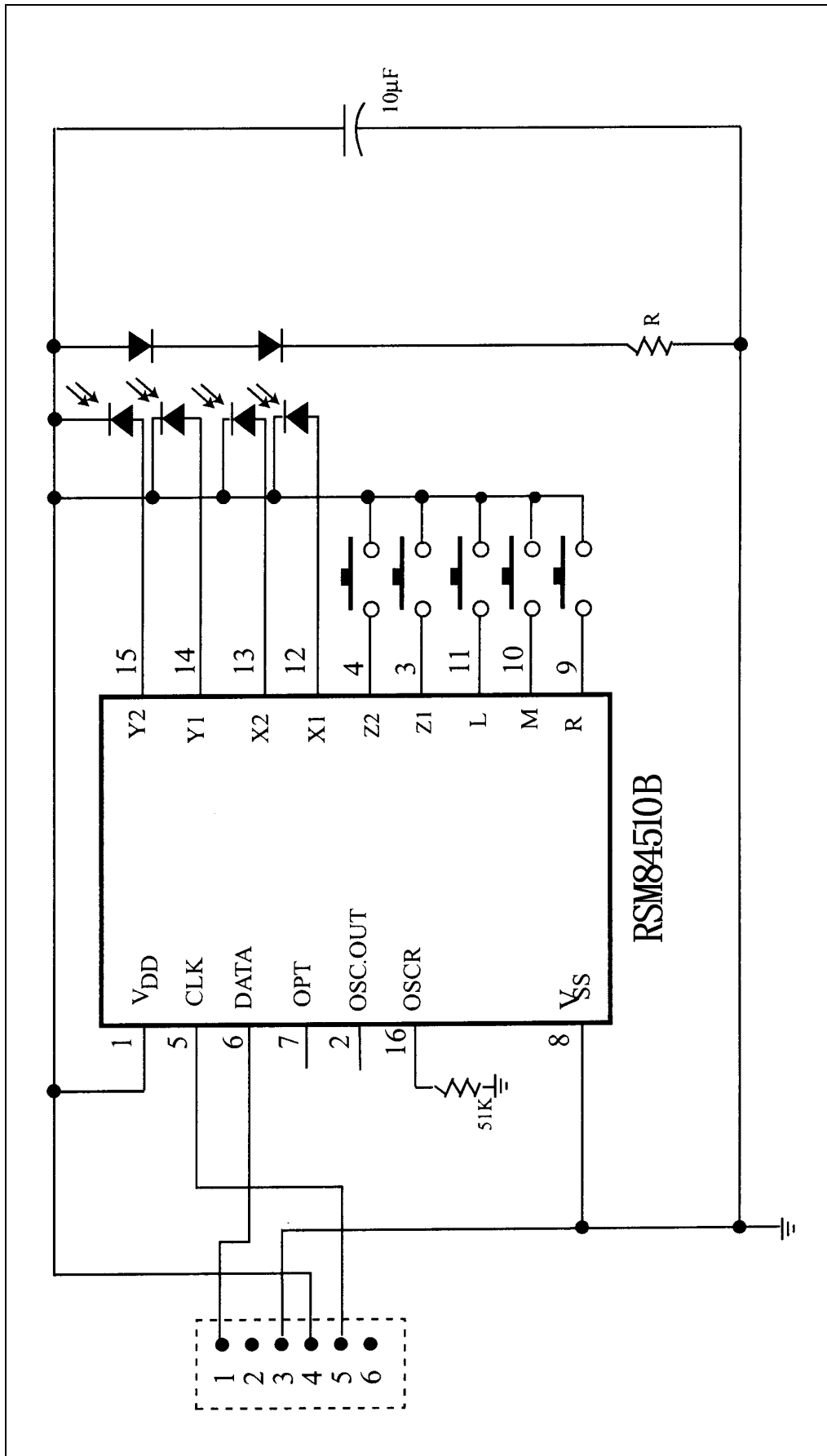

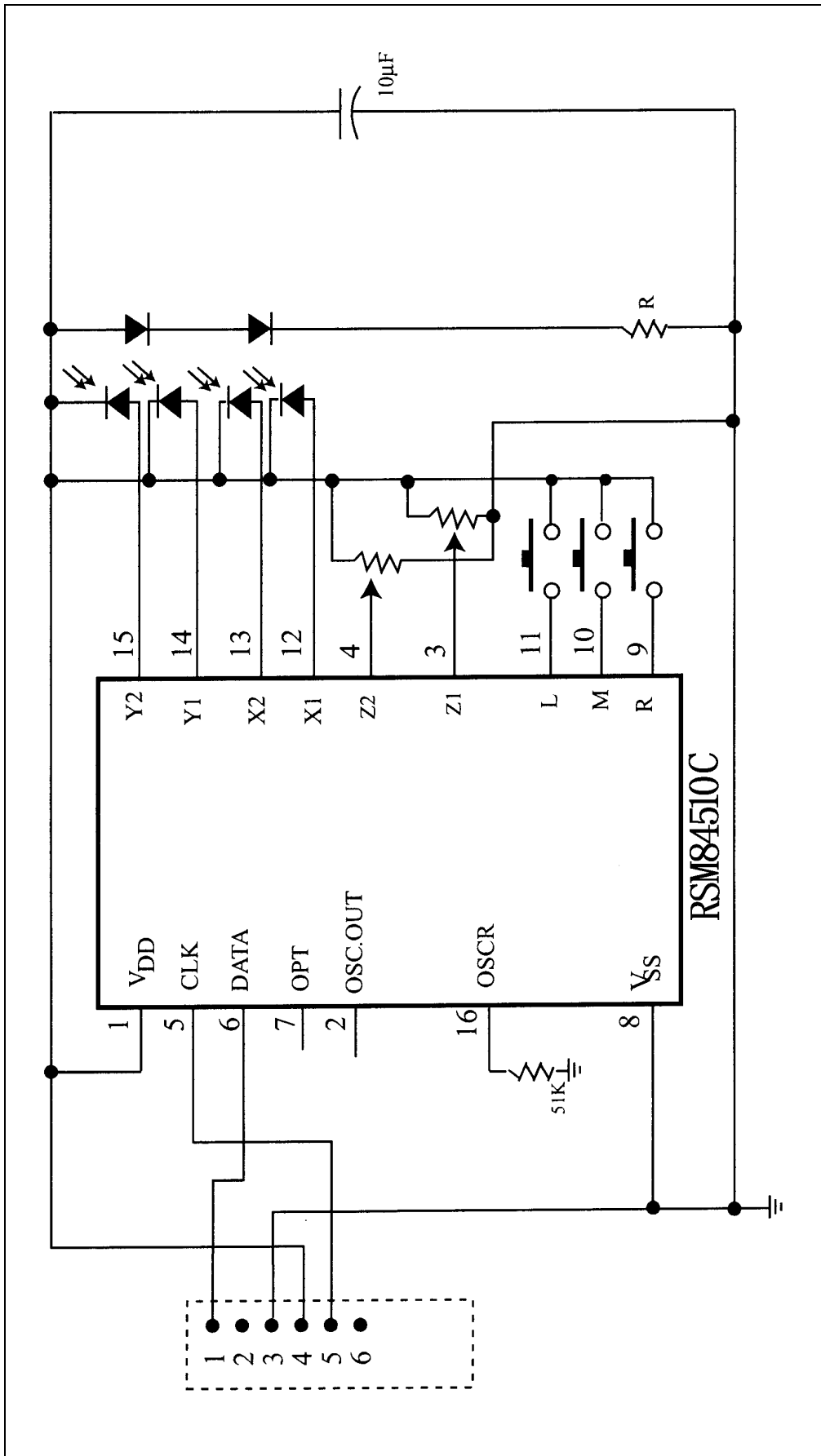



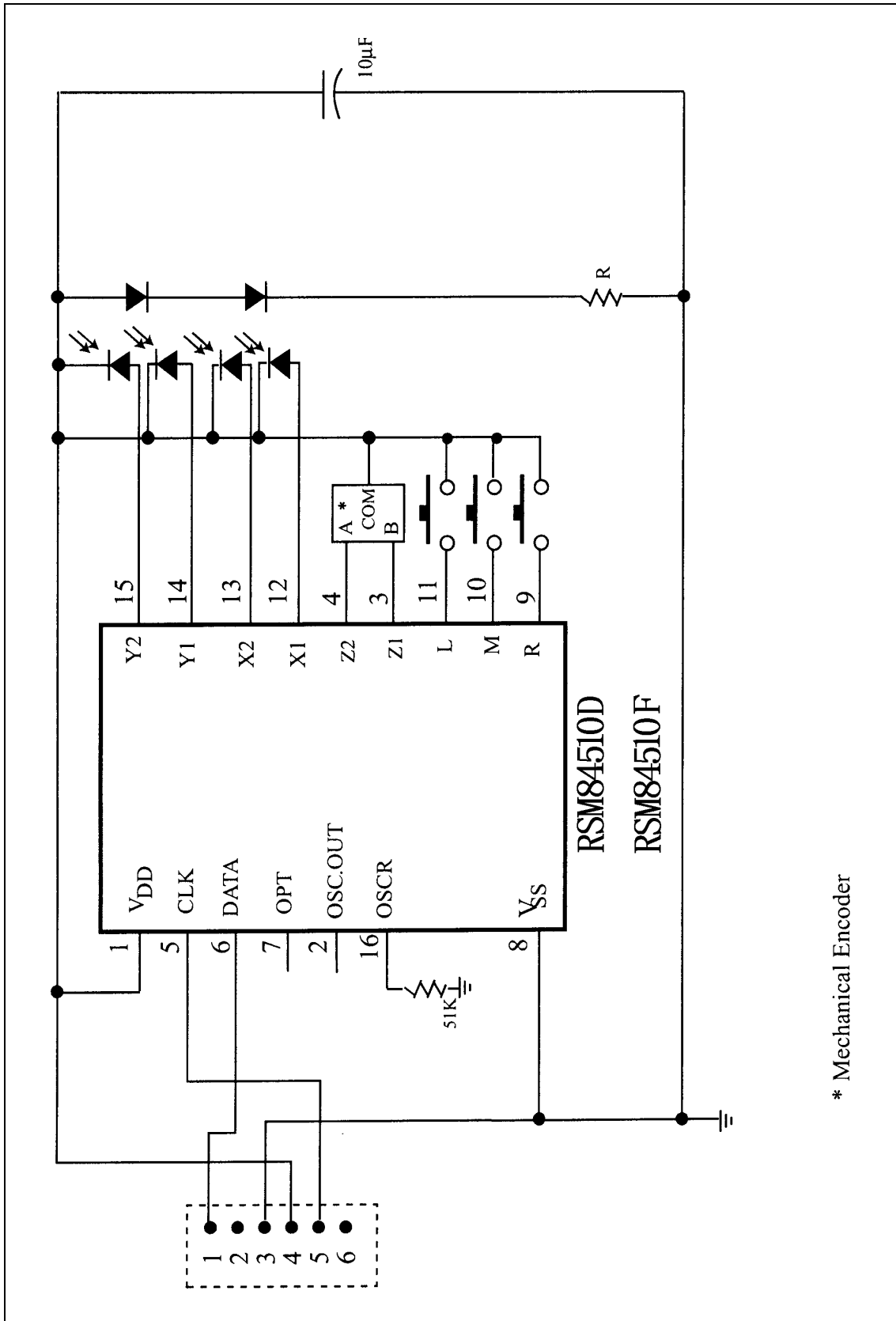

\* Mechanical Encoder