

PLEASE CHECK WWW.MOLEX.COM FOR LATEST PART INFORMATION

Part Number: **0039000062**
Status: **Active**
Overview: [minifit_jr](#)
Description: 4.20mm (.165") Pitch Mini-Fit™ Crimp Terminal, Male, Phosphor Bronze, Tin (Sn), 18-24 AWG, Bag

Documents:

Test Summary (PDF)	Product Specification PS-5556-001 (PDF)
Drawing (PDF)	Product Specification PS-5556-002 (PDF)
Product Specification PS-51010-003 (PDF)	Product Specification PS-5556-003 (PDF)
Product Specification PS-51010-004 (PDF)	RoHS Certificate of Compliance (PDF)

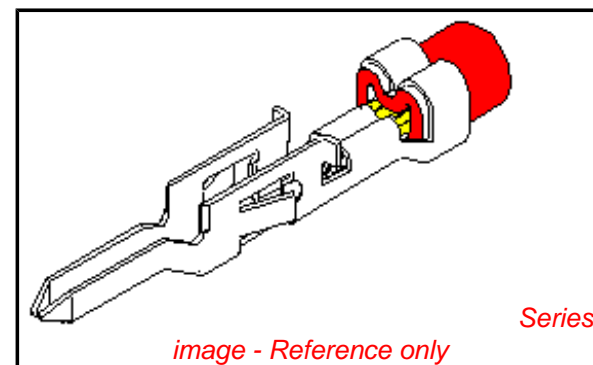

General

Product Family	Crimp Terminals
Series	5558
Crimp Quality Equipment	Yes
Overview	minifit_jr
Product Name	Mini-Fit®

Physical

Durability (mating cycles max)	30
Gender	Male
Material - Metal	Phosphor Bronze
Material - Plating Mating	Tin
Material - Plating Termination	Tin
Packaging Type	Bag
Plating min: Mating (µin)	36
Plating min: Mating (µm)	0.90
Plating min: Termination (µin)	36
Plating min: Termination (µm)	0.90
Termination Interface: Style	Crimp or Compression
Wire Insulation Diameter	1.30-3.10mm (.051-.122")
Wire Size AWG	18, 20, 22, 24
Wire Size mm²	N/A

Electrical

Current - Maximum per Contact	9A
Voltage - Maximum	600V

Material Info

Old Part Number	5558PBTL
-----------------	----------

Reference - Drawing Numbers

Packaging Specification	PK-5556-003, SPK-5558-001
Product Specification	PS-51010-003, PS-51010-004, PS-5556-001, PS-5556-002, PS-5556-003, RPS-52034-001
Sales Drawing	SD-5558****
Test Summary	TS-5556-002

EU RoHS

ELV and RoHS Compliant
REACH SVHC Contains SVHC: No
Halogen-Free Status

China RoHS



Need more information on product environmental compliance?

Email productcompliance@molex.com
 For a multiple part number RoHS Certificate of Compliance, [click here](#)

Please visit the [Contact Us](#) section for any non-product compliance questions.

Search Parts in this Series

5558Series

Mates With

5556 Mini-Fit™ Crimp Terminal

Use With

5559 Mini-Fit Jr.™ Plug Housing, 30068 Mini-Fit TPA™ Plug Housing, 42475 Mini-Fit BMI™ Plug Housing

Application Tooling | FAQ

Tooling specifications and manuals are found by selecting the products below. Crimp Height Specifications are then contained in the Application Tooling Specification document.

Global

Description	Product #
Extraction Tool	0011030044
Hand Crimp Tool for Mini-Fit™ Jr. Male and Female Crimp Terminals, 16-24 AWG	0638190900

Japan**Description****Product #**Handtool (Straight
Action) 0570225500Hand Crimp Tool 0570265000

This document was generated on 06/01/2010

PLEASE CHECK WWW.MOLEX.COM FOR LATEST PART INFORMATION

NOTES

1. MATERIAL: SEE CHART
2. FINISH: SEE CHART
3. PRODUCT SPECIFICATION: PS-5556-001, PS-5556-002, PS-5556-003
4. PACKAGING SPECIFICATION: PK-5558-001 FOR CHAIN
PK-5556-003 FOR LOOSE
5. MATES WITH TERMINAL: 5556 SERIES.
6. APPLICABLE HOUSING: 5559, 30068, 42475 SERIES.
7. THE NUMBER OF SERRATIONS TO BE ONE FOR WIRE RANGE #22-28.
8. WHEN TERMINALS ARE INSTALLED IN THE HOUSING THE WIRES ARE TO BE DRESSED IN SUCH A MANNER TO ALLOW THE TERMINALS TO FLOAT FREELY IN THE POCKET.
9. THIS TERMINAL IS DESIGNED FOR SINGLE WIRE CRIMPING.
10. PART CONFORMS TO CLASS "B" REQUIREMENTS OF COSMETIC SPECIFICATION PS-45499-002.

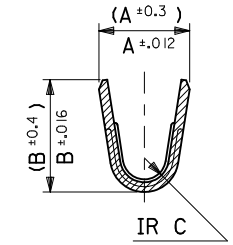
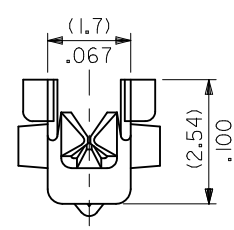
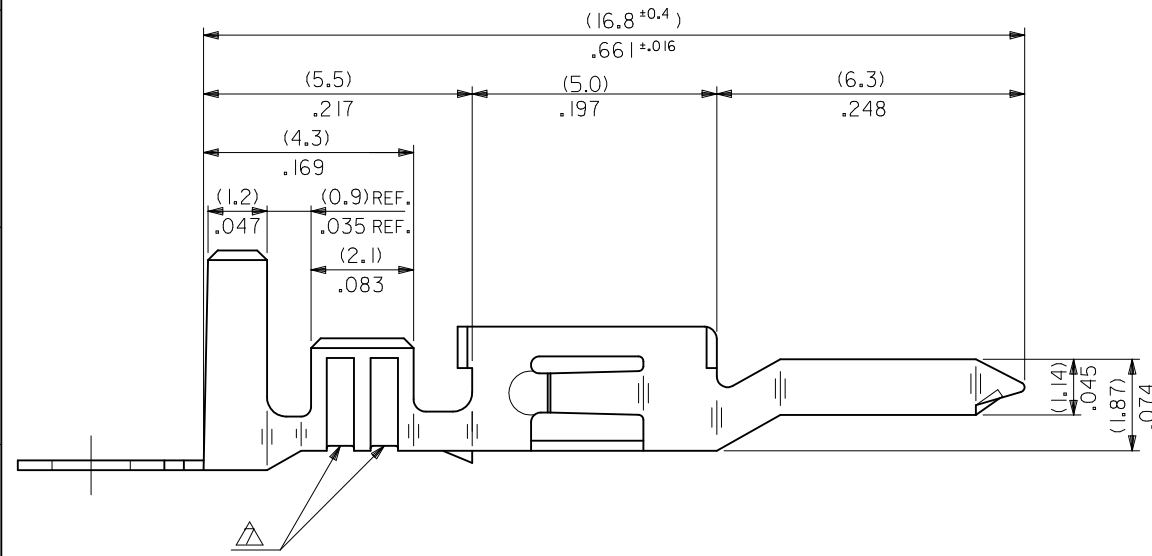
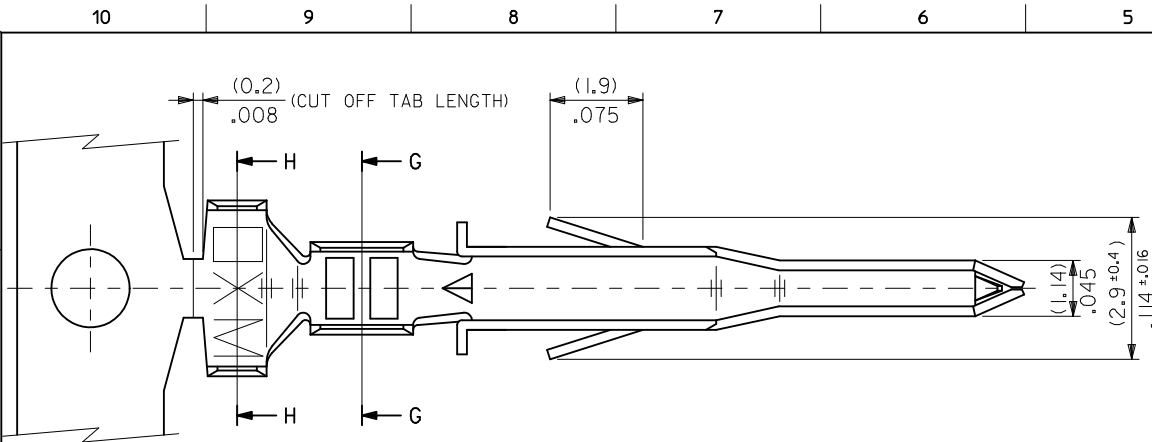

SECT. G-G

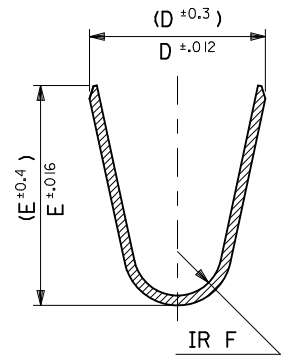

SECT. H-H

UPDATED NOTES EC NO: UCP2010-2478 DRWN: J JAGUILAR 2010/04/06 CHKD: JBELL 2010/04/09 APPR: F SMITH 2010/04/09	DESCRIPTION REV	QUALITY SYMBOLS	GENERAL TOLERANCES (UNLESS SPECIFIED)	DIMENSION STYLE	SCALE	DESIGN UNITS	THIRD ANGLE PROJECTION	
		$\nabla F=0$ $\nabla E=0$ $\nabla E=0$	mm INCH 4 PLACES ± --- ± --- 3 PLACES ± --- ± .008 2 PLACES ± .20 ± .008 1 PLACE ± .2 ± --- ANGULAR ± 3 °	MM/IN	10:1	METRIC	DRAWN BY H.HIRAMOTO DATE 1991/03/12 CHECKED BY S.KUNISHI DATE 1998/07/07 APPROVED BY P.S.MURAKUSHIMA DATE 1998/07/07	TITLE MINI-FIT JR OVERALL TIN MALE CRIMP TERMINAL
		DRAFT WHERE APPLICABLE MUST REMAIN WITHIN DIMENSIONS	SEE CHART	MATERIAL NO.	DOCUMENT NO.	MOLEX INCORPORATED SD-5558****		SHEET NO. 1 OF 2
		SIZE B	THIS DRAWING CONTAINS INFORMATION THAT IS PROPRIETARY TO MOLEX INCORPORATED AND SHOULD NOT BE USED WITHOUT WRITTEN PERMISSION					

10 9 8 7 6 5 4 3 2 1

TIN PLATED PHOSPHOR BRONZE	(0.9) .035	(4.5) .177	(3.6) .142	(0.6) .024	(2.7) .106	(2.3) .091	∅ (3.1) .122 MAX.	# 16	39-00-0084	5558 PBT3L	LOOSE
	(0.6) .024	(2.3) .091	(2.3) .091	(0.4) .016	(1.65) .065	(1.8) .071	∅ (0.9-1.8) .035-.071	#22-28	↑ -0083	↑ PBT3	CHAIN
	(0.9) .035	(4.5) .177	(3.6) .142	(0.5) .020	(2.3) .091	(1.9) .075	∅ (1.3-3.1) .051-.122	#18-24	-0068	PBT2L	LOOSE
TIN OVER COPPER PLATED BRASS	(0.6) .024	(2.3) .091	(2.3) .091	(0.4) .016	(1.65) .065	(1.8) .071	∅ (0.9-1.8) .035-.071	#22-28	-0067	PBT2	CHAIN
	(0.9) .035	(4.5) .177	(3.6) .142	(0.5) .020	(2.3) .091	(1.9) .075	∅ (1.3-3.1) .051-.122	#18-24	-0062	PBTL	LOOSE
	(0.9) .035	(4.5) .177	(3.6) .142	(0.6) .024	(2.7) .106	(2.3) .091	∅ (3.1) .122 MAX.	# 16	-0061	PBT	CHAIN
MATERIAL	(0.6) .024	(2.3) .091	(2.3) .091	(0.4) .016	(1.65) .065	(1.8) .071	∅ (0.9-1.8) .035-.071	#22-28	↓ -0082	T3L	LOOSE
	(0.9) .035	(4.5) .177	(3.6) .142	(0.5) .020	(2.3) .091	(1.9) .075	∅ (1.3-3.1) .051-.122	#18-24	-0081	T3	CHAIN
	(0.6) .024	(2.3) .091	(2.3) .091	(0.4) .016	(1.65) .065	(1.8) .071	∅ (0.9-1.8) .035-.071	#22-28	-0049	T2L	LOOSE
	(0.9) .035	(4.5) .177	(3.6) .142	(0.5) .020	(2.3) .091	(1.9) .075	∅ (1.3-3.1) .051-.122	#18-24	-0048	T2	CHAIN
									↓ -0041	↓ TL	LOOSE
									39-00-0040	5558 T	CHAIN
	F	E	D	C	B	A	INS. RANGE	WIRE RANGE	EDP NO.	ENG. NO.	FORM

UPDATE TITLE BLOCK EC NO: UCP2010-2478 DRWN: J JAGUILAR 2010/04/06 CHKD: JBELL 2010/04/09 APPR: FSMITH 2010/04/09 REV DESCRIPTION	QUALITY SYMBOLS	GENERAL TOLERANCES (UNLESS SPECIFIED)	DIMENSION STYLE	SCALE	DESIGN UNITS	THIRD ANGLE PROJECTION
	▽ F=0	mm INCH	MM/IN	10:1	METRIC	
	▽ F=0	4 PLACES ± --- ± ---	DRAWN BY DATE	TITLE		
	▽ F=0	3 PLACES ± --- ± .008	H.HIRAMOTO 1991/03/12	MINI-FIT JR OVERALL TIN MALE CRIMP TERMINAL		
	2 PLACES ± .20 ± .008	CHECKED BY DATE	MOLEX INCORPORATED			
	1 PLACE ± .2 ± ---	S.KUNISHI 1998/07/07	DOCUMENT NO.			
	ANGULAR ± 3 °	APPROVED BY DATE	SD-5558****			
		FSMITH KUSHIMA 2010/07/09	SHEET NO.			
		MATERIAL NO.	2 OF 2			
		SEE CHART	THIS DRAWING CONTAINS INFORMATION THAT IS PROPRIETARY TO MOLEX INCORPORATED AND SHOULD NOT BE USED WITHOUT WRITTEN PERMISSION			

9 8 7 6 5 4 3 2 1