



4-, 5-, 6-Channel, Muxed Input Line Inversion LCD Gamma Buffers

ADD8504/ADD8505/ADD8506

FEATURES

- Single-supply operation: 3.3 V to 6.5 V
- Rail-to-rail input, rail-to-rail output
- High output current: 380 mA
- Low supply current: 3.9 mA
- Stable with 1 nF loads
- Wide temperature range: -40°C to $+105^{\circ}\text{C}$
- 16-, 20-, and 24-lead, Pb-free, TSSOP packages

APPLICATIONS

- LCD line inversion gamma references
- Car navigation panels
- Personal media player panels

GENERAL DESCRIPTION

The ADD8504, ADD8505, and ADD8506 are 4-, 5-, and 6-channel LCD gamma reference buffers designed to drive column driver gamma inputs in line inversion panels. Each buffer channel has an A/B input to select between two gamma voltage curves. These buffer channels drive the resistor ladders of LCD column drivers for gamma correction. The ADD8504/ADD8505/ADD8506 outputs have high slew rates and output drives that increase the stability of the reference ladder resulting in optimal gray scale and visual performance.

The ADD8504/ADD8505/ADD8506 are specified over the -40°C to $+105^{\circ}\text{C}$ temperature range. They are available, respectively, in 16-, 20-, and 24-lead thin shrink small outline (TSSOP), surface-mount, Pb-free packages.

PIN CONFIGURATION DIAGRAMS

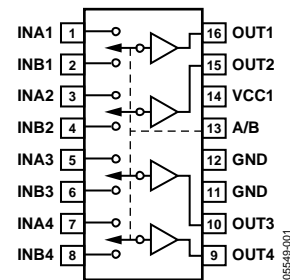

Figure 1. ADD8504: 4-Channel Buffer

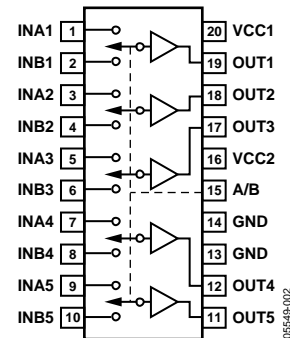

Figure 2. ADD8505: 5-Channel Buffer

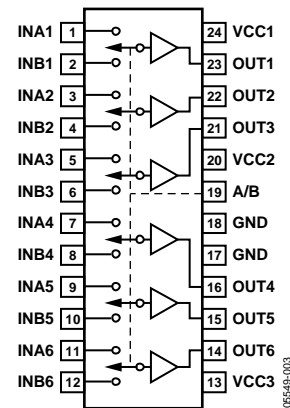

Figure 3. ADD8506: 6-Channel Buffer

Rev. B

Information furnished by Analog Devices is believed to be accurate and reliable. However, no responsibility is assumed by Analog Devices for its use, nor for any infringements of patents or other rights of third parties that may result from its use. Specifications subject to change without notice. No license is granted by implication or otherwise under any patent or patent rights of Analog Devices. Trademarks and registered trademarks are the property of their respective owners.

TABLE OF CONTENTS

Features	1	Thermal Resistance	4
Applications.....	1	ESD Performance	4
General Description	1	ESD Caution.....	4
Pin Configuration Diagrams.....	1	Pin Configurations and Function Descriptions	5
Revision History	2	Typical Performance Characteristics	6
Specifications.....	3	Applications.....	7
Electrical Characteristics.....	3	Outline Dimensions	8
Absolute Maximum Ratings.....	4	Ordering Guide	8

REVISION HISTORY

1/06—Rev. A to Rev. B

Added Pin Configurations and Function Descriptions Section	5
Added Table 5.....	8

10/05—Rev. 0 to Rev. A

Added ADD8504 and ADD8505.....	Universal
Changes to Specifications Section	3
Updated Outline Dimensions	7
Changes to Ordering Guide	7

9/05—Revision 0: Initial Version

SPECIFICATIONS

ELECTRICAL CHARACTERISTICS

$V_{CC} = 5\text{ V}$, $T_A = 25^\circ\text{C}$, unless otherwise noted. V_{IN} denotes buffer input voltage; I_{LOAD} denotes load current; R_L denotes load resistance; C_L denotes load capacitance.

Table 1.

Parameter	Symbol	Conditions	Min	Typ	Max	Unit
INPUT CHARACTERISTICS						
Offset Voltage	V_{OS}	$0\text{ V} \leq V_{IN} \leq 5\text{ V}$			20	mV
Input Common-Mode Voltage Range	V_{CM}		0		5	V
Input Bias Current	I_B	$V_{IN} = 2.5\text{ V}$		2	50	nA
Voltage Gain	A_{VO}		0.985			V/V
OUTPUT CHARACTERISTICS						
Output Voltage High	V_{OH}	$I_{LOAD} = +20\text{ mA}$	4.75			V
Output Voltage Low	V_{OL}	$I_{LOAD} = -20\text{ mA}$			0.2	V
Output Resistance	R_{OUT}	$-20\text{ mA} \leq I_{LOAD} \leq +20\text{ mA}$; $0.5\text{ V} \leq V_{IN} \leq 4.5\text{ V}$		0.20		Ω
Output Short-Circuit Current	I_{SC}		120	380		mA
POWER SUPPLY						
Supply Current	I_{SY}	$V_{IN} = 2.5\text{ V}$				
ADD8504				2.7	3.8	mA
ADD8505				3.0	4.4	mA
ADD8506				3.9	5.1	mA
Supply Voltage Range	V_{CC}		3.3		6.5	V
DYNAMIC PERFORMANCE						
Slew Rate	SR	$C_L = 15\text{ pF}$ $R_L = 250\ \Omega$		7.0		V/ μs
Settling Time	t_S	$C_L = 200\text{ pF}$, $R_L = 10\text{ k}\Omega$		6.2		V/ μs
				2.5	6	μs
LOGIC INPUT CHARACTERISTICS						
Input Current Low	I_{IL}	$V_{IN} = 0.0\text{ V}$			100	nA
Input Current High	I_{IH}	$V_{IN} = 5.0\text{ V}$			100	nA
Input Voltage Low	V_{IL}	$V_{CC} = 5.0\text{ V}$, $-40^\circ\text{C} \leq T_A \leq 105^\circ\text{C}$			0.8	V
Input Voltage Low	V_{IL}	$V_{CC} = 3.3\text{ V}$, $-40^\circ\text{C} \leq T_A \leq 105^\circ\text{C}$			0.7	V
Input Voltage High	V_{IH}	$V_{CC} = 5.0\text{ V}$, $-40^\circ\text{C} \leq T_A \leq 105^\circ\text{C}$	1.7			V
Input Voltage High	V_{IH}	$V_{CC} = 3.3\text{ V}$, $-40^\circ\text{C} \leq T_A \leq 105^\circ\text{C}$	1.4			V

ADD8504/ADD8505/ADD8506

ABSOLUTE MAXIMUM RATINGS

Table 2.

Parameter	Rating
Supply Voltage	7 V
Input Voltage	GND to V _{CC}
Storage Temperature Range	-65°C to +150°C
Junction Temperature Range	-65°C to +150°C
Lead Temperature (Soldering, 60 sec)	300°C

Stresses beyond those listed under Absolute Maximum Ratings may cause permanent damage to the device. This is a stress rating only; functional operation of the device at these or any other conditions above those indicated in the operational section of this specification is not implied. Exposure to absolute maximum rating conditions for extended periods may affect device reliability.

THERMAL RESISTANCE

Table 3. Thermal Package Characteristics

Model	Package Type	θ_{JA}^1	θ_{JC}^2	Unit
ADD8504WRUZ	16-Lead Pb-Free TSSOP	150	28	°C/W
ADD8505WRUZ	20-Lead Pb-Free TSSOP	143	45	°C/W
ADD8506WRUZ	24-Lead Pb-Free TSSOP	128	45	°C/W

¹ θ_{JA} is specified for natural convection on a two-layer board.

² θ_{JC} is specified for natural convection on a two-layer board.

ESD PERFORMANCE

Table 4.

Model	HBM ¹	MM ²	FICDM ³
ADD8504WRUZ	4.0 kV	400 V	1.0 kV
ADD8505WRUZ	3.5 kV	200 V	1.0 kV
ADD8506WRUZ	3.5 kV	200 V	1.0 kV

¹ Human body model.

² Machine model.

³ Field induced charge device model.

ESD CAUTION

ESD (electrostatic discharge) sensitive device. Electrostatic charges as high as 4000 V readily accumulate on the human body and test equipment and can discharge without detection. Although this product features proprietary ESD protection circuitry, permanent damage may occur on devices subjected to high energy electrostatic discharges. Therefore, proper ESD precautions are recommended to avoid performance degradation or loss of functionality.



PIN CONFIGURATIONS AND FUNCTION DESCRIPTIONS

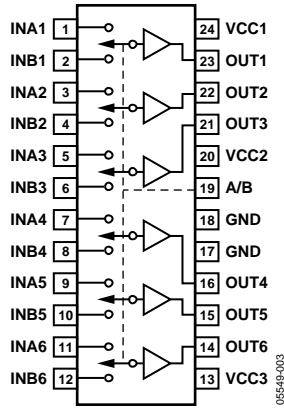

Figure 4. ADD8506
6-Channel Buffer

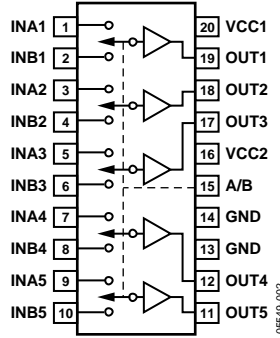

Figure 5. ADD8505
5-Channel Buffer

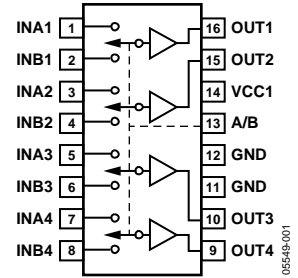

Figure 6. ADD8504
4-Channel Buffer

Table 5. Pin Function Descriptions

ADD8506 Pin No.	ADD8505 Pin No.	ADD8504 Pin No.	Mnemonic	Function	Description
1	1	1	INA1	Input	Channel 1 Buffer Input A.
2	2	2	INB1	Input	Channel 1 Buffer Input B.
3	3	3	INA2	Input	Channel 2 Buffer Input A.
4	4	4	INB2	Input	Channel 2 Buffer Input B.
5	5	5	INA3	Input	Channel 3 Buffer Input A.
6	6	6	INB3	Input	Channel 3 Buffer Input B.
7	7	7	INA4	Input	Channel 4 Buffer Input A.
8	8	8	INB4	Input	Channel 4 Buffer Input B.
9	9	N/A	INA5	Input	Channel 5 Buffer Input A.
10	10	N/A	INB5	Input	Channel 5 Buffer Input B.
11	N/A	N/A	INA6	Input	Channel 6 Buffer Input A.
12	N/A	N/A	INB6	Input	Channel 6 Buffer Input B.
13	N/A	N/A	VCC3	Power In	Power Supply Input. Short to VCC1 and VCC2. Typically connected to +5 V.
14	N/A	N/A	OUT6	Output	Channel 6 Buffer Output.
15	11	N/A	OUT5	Output	Channel 5 Buffer Output.
16	12	9	OUT4	Output	Channel 4 Buffer Output.
17, 18	13, 14	11, 12	GND	Ground	Ground.
19	15	13	A/B	Input	Switch Control. Logic high selects Input A; logic low selects Input B.
20	16	N/A	VCC2	Power In	Power Supply Input. Short to VCC1 and VCC3. Typically connected to +5 V.
21	17	10	OUT3	Output	Channel 3 Buffer Output.
22	18	15	OUT2	Output	Channel 2 Buffer Output.
23	19	16	OUT1	Output	Channel 1 Buffer Output.
24	20	14	VCC1	Power In	Power Supply Input. Short to VCC2 and VCC3. Typically connected to +5 V.

TYPICAL PERFORMANCE CHARACTERISTICS

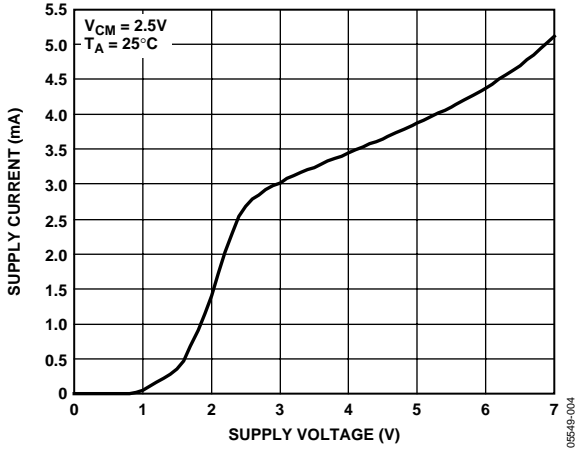

Figure 7. Supply Current vs. Supply Voltage

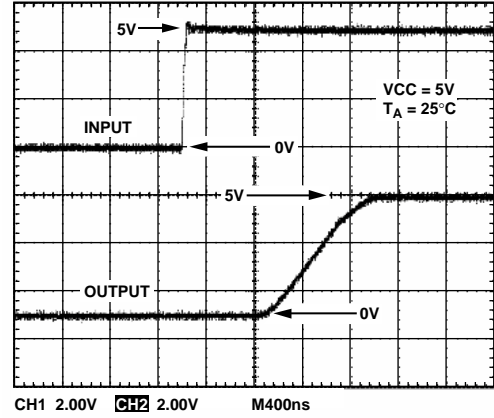

Figure 10. Transient Response—Rising

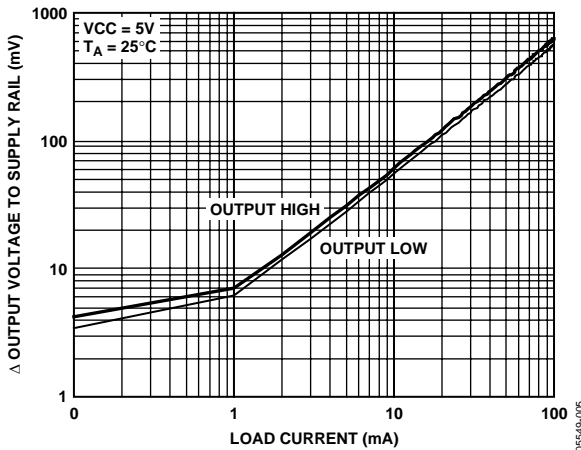

Figure 8. Δ Output Voltage to Supply Rail vs. Load Current

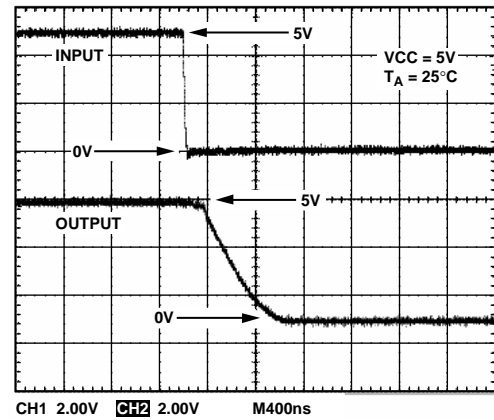

Figure 11. Transient Response—Falling

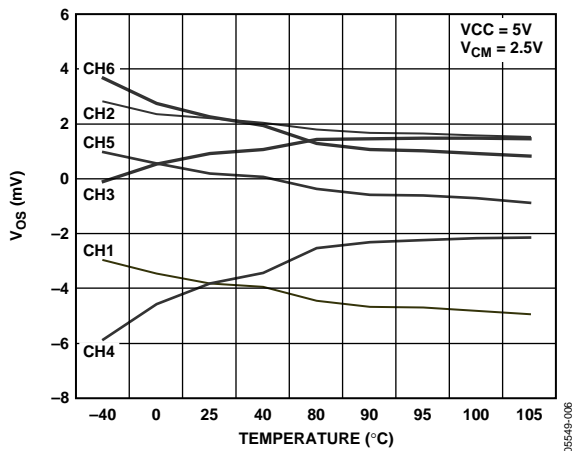

Figure 9. Offset Voltage vs. Temperature

APPLICATIONS

The ADD8504/ADD8505/ADD8506 have CMOS buffers with A/B inputs to select between two different reference voltages set up by an external resistor ladder. Input bias currents are orders of magnitude less than competitive parts. This allows the use of a very large resistor ladder to save supply current.

The buffer outputs are designed to drive resistive or capacitive loads. Therefore, to attain the best display performance, do not use resistors in series with these outputs. Outputs have high slew rates and 6 μ s settling times. Each output delivers a minimum of 120 mA, ensuring a fast response to varying loads.

Power supply pins on the ADD8505 and ADD8506 have multiple ground (GND) and supply (VCC) connections. Because of the high peak currents that these buffers deliver, it is recommended that all GND and VCC pins be connected and suitably bypassed.

Table 6. MUX Function

A/B Select	Input
Logic High	INAx
Logic Low	INBx

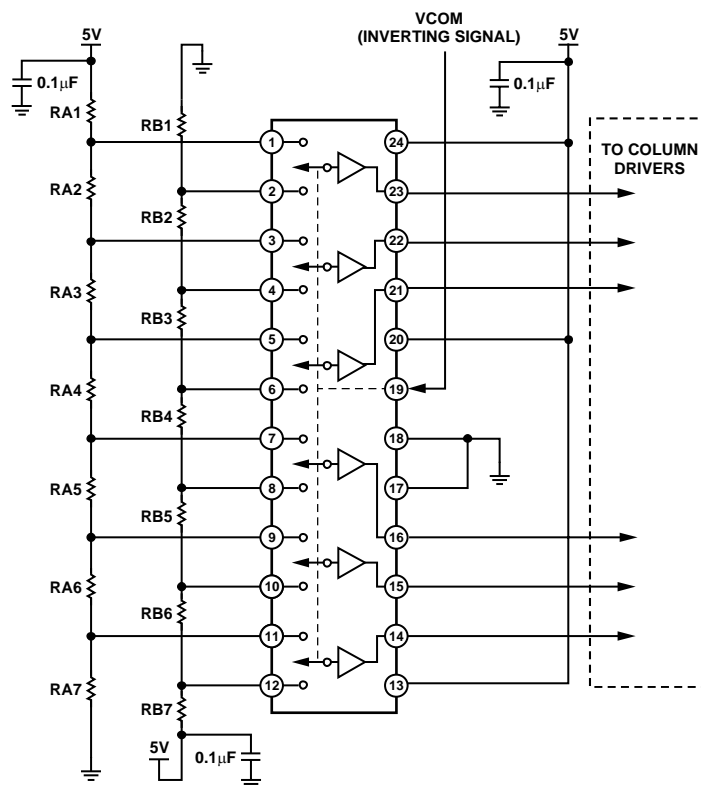

- NOTES**
1. RAx RESISTORS ARE USED TO SET POSITIVE INVERSION GAMMA VOLTAGES.
 2. RBx RESISTORS ARE USED TO SET NEGATIVE INVERSION GAMMA VOLTAGES.

05549-009

Figure 12. Typical Application

ADD8504/ADD8505/ADD8506

OUTLINE DIMENSIONS

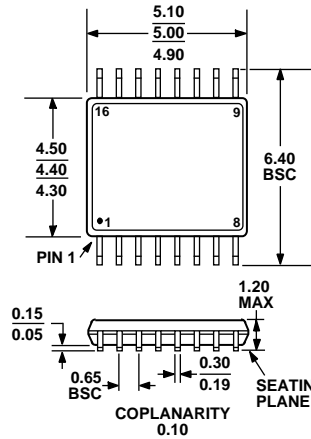

COMPLIANT TO JEDEC STANDARDS MO-153-AB
 Figure 13. 16-Lead Thin Shrink Small Outline Package [TSSOP]
 (RU-16)
 Dimensions shown in millimeters

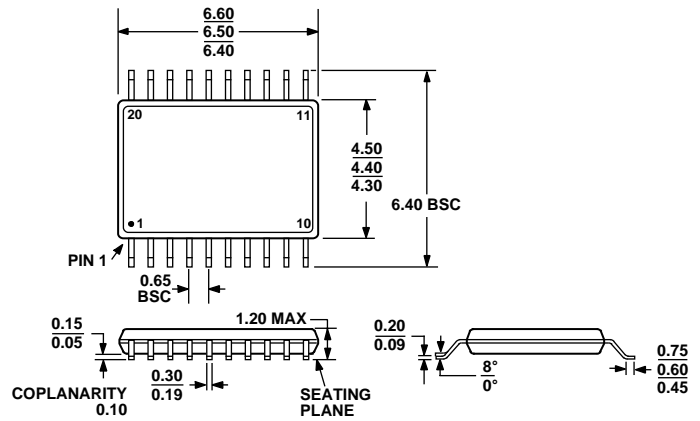

COMPLIANT TO JEDEC STANDARDS MO-153-AC
 Figure 14. 20-Lead Thin Shrink Small Outline Package [TSSOP]
 (RU-20)
 Dimensions shown in millimeters

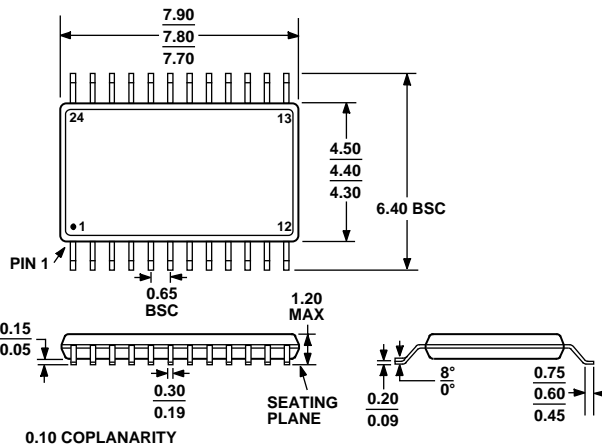

COMPLIANT TO JEDEC STANDARDS MO-153-AD
 Figure 15. 24-Lead Thin Shrink Small Outline Package [TSSOP]
 (RU-24)
 Dimensions shown in millimeters

ORDERING GUIDE

Model	Temperature Range	Package Description	Package Option	Ordering Quantity
ADD8504WRUZ ¹	-40°C to +105°C	16-Lead Thin Shrink Small Outline Package [TSSOP], Tube	RU-16	96
ADD8504WRUZ-REEL7 ¹	-40°C to +105°C	16-Lead Thin Shrink Small Outline Package [TSSOP], 7" Reel	RU-16	1,000
ADD8504WRUZ-REEL ¹	-40°C to +105°C	16-Lead Thin Shrink Small Outline Package [TSSOP], 13" Reel	RU-16	2,500
ADD8505WRUZ ¹	-40°C to +105°C	20-Lead Thin Shrink Small Outline Package [TSSOP], Tube	RU-20	96
ADD8505WRUZ-REEL7 ¹	-40°C to +105°C	20-Lead Thin Shrink Small Outline Package [TSSOP], 7" Reel	RU-20	1,000
ADD8505WRUZ-REEL ¹	-40°C to +105°C	20-Lead Thin Shrink Small Outline Package [TSSOP], 13" Reel	RU-20	2,500
ADD8506WRUZ ¹	-40°C to +105°C	24-Lead Thin Shrink Small Outline Package [TSSOP], Tube	RU-24	96
ADD8506WRUZ-REEL7 ¹	-40°C to +105°C	24-Lead Thin Shrink Small Outline Package [TSSOP], 7" Reel	RU-24	1,000
ADD8506WRUZ-REEL ¹	-40°C to +105°C	24-Lead Thin Shrink Small Outline Package [TSSOP], 13" Reel	RU-24	2,500

¹ Z = Pb-free part.