

FM809/810

3-Pin μ C Supervisor Circuits

General Description

The FM809/810 are supervisor circuits that monitor power supply or other system voltages and issue reset pulses (FM809 = $\overline{\text{RESET}}$, FM810 = RESET) when a fault condition exists. Several threshold voltages are offered to accommodate system voltages of 5.0V, 3.3V, 3.0V and 2.7V with different tolerances.

The low supply current (typically 2 μ A) recommends the devices for portable designs or wherever power saving is primary.

The minimum RESET delay is 140ms, but this may be changed to a value between 32-256ms. Contact the factory for more information.

Features

- V_{TH} voltages of 4.63V, 4.38V, 4.00V, 3.08V, 2.93V and 2.63V (contact factory for lower values of V_{TH})
- $\overline{\text{RESET}}$ (FM809) or RESET (FM810) output

- 140ms power-on RESET delay (minimum)
- $\overline{\text{RESET}}$ operation guaranteed to 1.0V
- Supply current only 2 μ A
- No external components
- -40°C to +105°C Operating Range
- SOT23-3 package

Applications

- Microcontrollers and Microprocessors
- Appliances
- Power-Supply Monitoring
- Portable Equipment
- Automotive Systems

Typical Operating Circuit

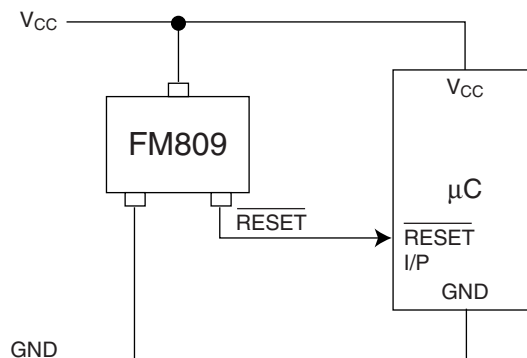

Connection Diagram

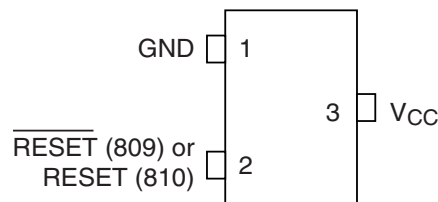

FM809/810
SOT23-3 Package

Absolute Maximum Ratings

Voltage on any terminal relative to GND

V_{CC} -0.3V to +6.0V
 $\overline{\text{RESET}}, \overline{\text{RESET}}$ -0.3V to ($V_{CC} + 0.3$ V)

Input Current 20mA

Output Current: $\overline{\text{RESET}}, \overline{\text{RESET}}$ 20mA

Rate of Rise of V_{CC} 100V/ μ s

Continuous Power Dissipation ($T_A = +70^\circ\text{C}$)
 SOT23-3 (derate 4mW/ $^\circ\text{C}$ above $+70^\circ\text{C}$) 320mW

Operating Temperature Range -40 $^\circ\text{C}$ to +105 $^\circ\text{C}$

Storage Temperature Range -65 $^\circ\text{C}$ to +150 $^\circ\text{C}$

Lead Temperature (soldering, 10s) +300 $^\circ\text{C}$

These are stress ratings only, and functional operation is not implied for these levels or beyond. Exposure to Absolute Maximum Rating conditions for extended periods may affect device reliability.

Electrical Characteristics ($T_A = 25^\circ\text{C}$ unless otherwise noted)

V_{CC} = full range, as noted under conditions. See Note 1.

Parameter	Symbol	Conditions	Min	Typ (Note 3)	Max	Units
Operating Voltage	V_{CC}	$T_A = 0^\circ\text{C}$ to $+70^\circ\text{C}$	1.0		5.5	V
		$T_A = -40^\circ\text{C}$ to 85°C	1.1		5.5	
Supply Current	I_{CC}	$T_A = -40^\circ\text{C}$ to 85°C , $V_{CC} < 5.5\text{V}$ FM809J/L/M		5	10	μA
		$T_A = -40^\circ\text{C}$ to 85°C , $V_{CC} < 3.6\text{V}$ FM809R/S/T		2	6	
Reset Threshold	V_{TH}	FM8xxL $T_A = -40^\circ\text{C}$ to $+105^\circ\text{C}$	4.40	4.63	4.86	V
		FM8xxM $T_A = -40^\circ\text{C}$ to $+105^\circ\text{C}$	4.18	4.38	4.52	
		FM8xxJ $T_A = -40^\circ\text{C}$ to $+105^\circ\text{C}$	3.90	4.00	4.18	
		FM8xxT $T_A = -40^\circ\text{C}$ to $+105^\circ\text{C}$	2.97	3.08	3.19	
		FM8xxS $T_A = -40^\circ\text{C}$ to $+105^\circ\text{C}$	2.79	2.93	3.00	
		FM8xxR $T_A = -40^\circ\text{C}$ to $+105^\circ\text{C}$	2.49	2.63	2.70	
Reset Threshold Tempco				30		ppm/ $^\circ\text{C}$
V_{CC} to Reset Delay (Note 2)		$V_{CC} = V_{TH}$ to ($V_{TH} - 100\text{mV}$)		10		μs
Reset Active Timeout Period		$T_A = -40^\circ\text{C}$ to $+85^\circ\text{C}$	140	256	560	ms
FM809 Output Low ($\overline{\text{RESET}}$)	V_{OL}	$V_{CC} = V_{TH}(\text{min})$, $I_{SINK} = 1.2\text{mA}$, FM809R/S/T			0.3	V
		$V_{CC} = V_{TH}(\text{min})$, $I_{SINK} = 3.2\text{mA}$, FM809J/L/M			0.4	
		$V_{CC} < 1.0\text{V}$, $I_{SINK} = 50\mu\text{A}$			0.3	
FM809 Output High ($\overline{\text{RESET}}$)	V_{OH}	$V_{CC} > V_{TH}(\text{max})$, $I_{SOURCE} = 500\mu\text{A}$	0.8 V_{CC}			V
		$V_{CC} > V_{TH}(\text{max})$, $I_{SOURCE} = 800\mu\text{A}$	$V_{CC} - 1.5\text{V}$			
FM810 Output Low ($\overline{\text{RESET}}$)	V_{OL}	$V_{CC} = V_{TH}(\text{max})$, $I_{SINK} = 1.2\text{mA}$, FM810R/S/T			0.3	V
		$V_{CC} = V_{TH}(\text{max})$, $I_{SINK} = 3.2\text{mA}$, FM810J/L/M			0.4	
FM810 Output High ($\overline{\text{RESET}}$)	V_{OH}	$1.8\text{V} < V_{CC} < V_{TH}(\text{min})$, $I_{SOURCE} = 150\mu\text{A}$	0.8 V_{CC}			V

Note 1: Testing in production is 25 $^\circ\text{C}$ only. Limits over temperature are guaranteed by design.

Note 2: $\overline{\text{RESET}}$ output is for FM809. $\overline{\text{RESET}}$ output is for FM810.

Note 3: Typical values are at 25 $^\circ\text{C}$.

Pin Descriptions

Pin Number	Name	Function
1	GND	GROUND
2	RESET*	RESET (RESET) remains LOW (HIGH) while V_{CC} is below V_{TH} , and for at least 140ms after V_{CC} rises above V_{TH} .
3	V_{CC}	

* with overbar, FM809 ($\overline{\text{RESET}}$); without, FM810 (RESET).

Circuit Timing (Ex: FM809)

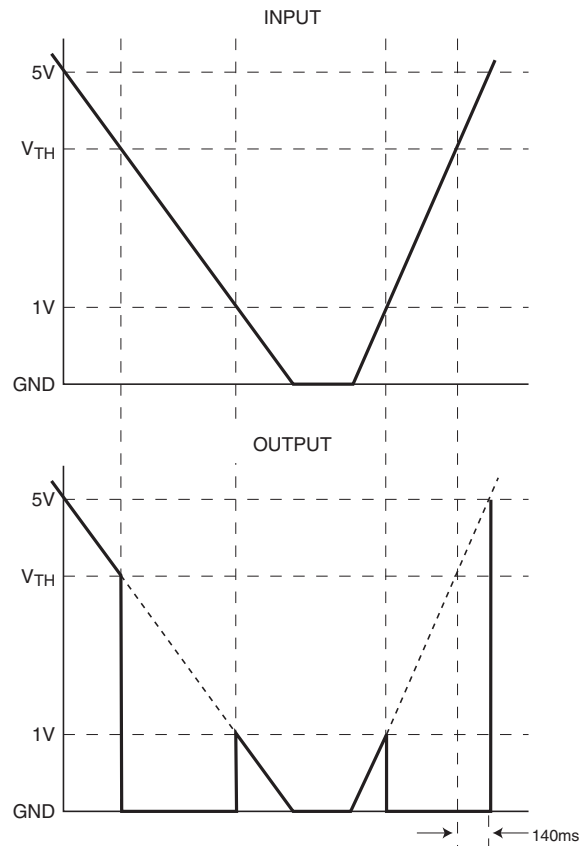

When operating properly with 5V in (for example), V_{OUT} will also be about 5V. When V_{IN} starts to fall, V_{OUT} will follow it down as shown. When V_{IN} drops below V_{TH} , V_{OUT} drops to ground ("issues a RESET") and stays there unless V_{IN} also falls below its minimum operating voltage, approx. 1V. At this point, the supervisor loses control, and its output may rise, only to again follow V_{IN} down to the ground.

When V_{IN} begins to rise, V_{OUT} follows it until 1.0V or so is reached, whereupon the device regains control, V_{OUT} is pulled to ground, etc. When V_{IN} rises above V_{TH} , V_{OUT} comes out of RESET 140 ms later.

If it is required that a lower value than $GND + 1.0V$ is needed on RESET signal during $V_{CC} \leq 1V$, a 100K resistor may be used on the device output (to GND for the FM809, to V_{CC} for the FM810).

Typical Operating Characteristics

Supply Current Vs. Temperature

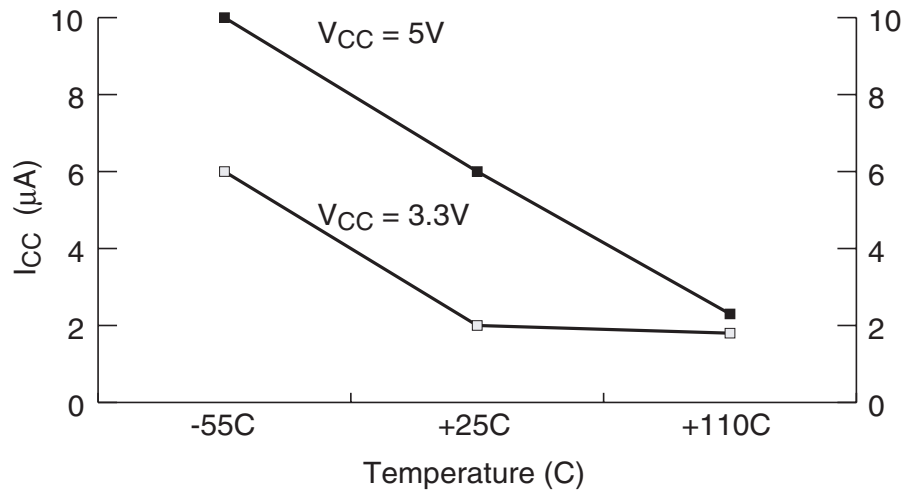

Power up Reset Timeout Vs. Temperature

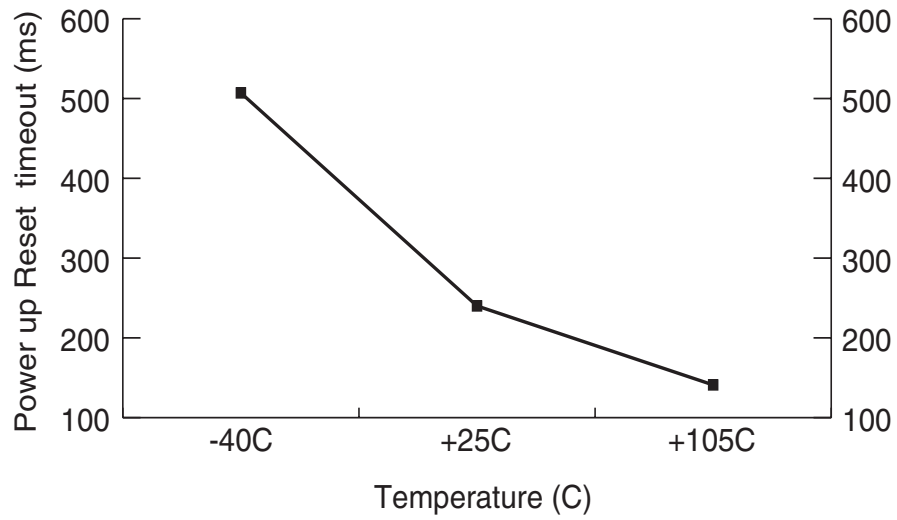

Ordering Information (FM809)

Part Number	Top Marking	RESET Threshold (V)	RESET Pulse Width (ms)	Output Type	Package Type
FM809LS3	09L	4.63	256	Push-Pull, active LOW	3-Pin, SOT23
FM809MS3	09M	4.38	256	Push-Pull, active LOW	3-Pin, SOT23
FM809JS3	09J	4.00	256	Push-Pull, active LOW	3-Pin, SOT23
FM809TS3	09T	3.08	256	Push-Pull, active LOW	3-Pin, SOT23
FM809SS3	09S	2.93	256	Push-Pull, active LOW	3-Pin, SOT23
FM809RS3	09R	2.63	256	Push-Pull, active LOW	3-Pin, SOT23
FM809LES3 (Note 4)	09LE	4.63	32	Push-Pull, active LOW	3-Pin, SOT23
FM809MES3 (Note 4)	09ME	4.38	32	Push-Pull, active LOW	3-Pin, SOT23
FM809JES3 (Note 4)	09JE	4.00	32	Push-Pull, active LOW	3-Pin, SOT23
FM809TES3 (Note 4)	09TE	3.08	32	Push-Pull, active LOW	3-Pin, SOT23
FM809SES3 (Note 4)	09SE	2.93	32	Push-Pull, active LOW	3-Pin, SOT23
FM809RES3 (Note 4)	09RE	2.63	32	Push-Pull, active LOW	3-Pin, SOT23
FM809LFS3 (Note 4)	09LF	4.63	64	Push-Pull, active LOW	3-Pin, SOT23
FM809MFS3 (Note 4)	09MF	4.38	64	Push-Pull, active LOW	3-Pin, SOT23
FM809JFS3 (Note 4)	09JF	4.00	64	Push-Pull, active LOW	3-Pin, SOT23
FM809TFS3 (Note 4)	09TF	3.08	64	Push-Pull, active LOW	3-Pin, SOT23
FM809SFS3 (Note 4)	09SF	2.93	64	Push-Pull, active LOW	3-Pin, SOT23
FM809RFS3 (Note 4)	09RF	2.63	64	Push-Pull, active LOW	3-Pin, SOT23
FM809LHS3 (Note 4)	09LH	4.63	128	Push-Pull, active LOW	3-Pin, SOT23
FM809MHS3 (Note 4)	09MH	4.38	128	Push-Pull, active LOW	3-Pin, SOT23
FM809JHS3 (Note 4)	09JH	4.00	128	Push-Pull, active LOW	3-Pin, SOT23
FM809THS3 (Note 4)	09TH	3.08	128	Push-Pull, active LOW	3-Pin, SOT23
FM809SHS3 (Note 4)	09SH	2.93	128	Push-Pull, active LOW	3-Pin, SOT23
FM809RHS3 (Note 4)	09RH	2.63	128	Push-Pull, active LOW	3-Pin, SOT23

Note 4: These devices are available upon special request only. Please contact Fairchild sales for availability and minimum ordering requirements.

Ordering Information (FM810)

Part Number	Top Marking	RESET Threshold (V)	RESET Pulse Width (ms)	Output Type	Package Type
FM810LS3	10L	4.63	256	Push-Pull, active HIGH	3-Pin, SOT23
FM810MS3	10M	4.38	256	Push-Pull, active HIGH	3-Pin, SOT23
FM810JS3	10J	4.00	256	Push-Pull, active HIGH	3-Pin, SOT23
FM810TS3	10T	3.08	256	Push-Pull, active HIGH	3-Pin, SOT23
FM810SS3	10S	2.93	256	Push-Pull, active HIGH	3-Pin, SOT23
FM810RS3	10R	2.63	256	Push-Pull, active HIGH	3-Pin, SOT23
FM810LES3 (Note 5)	10LE	4.63	32	Push-Pull, active HIGH	3-Pin, SOT23
FM810MES3 (Note 5)	10ME	4.38	32	Push-Pull, active HIGH	3-Pin, SOT23
FM810JES3 (Note 5)	10JE	4.00	32	Push-Pull, active HIGH	3-Pin, SOT23
FM810TES3 (Note 5)	10TE	3.08	32	Push-Pull, active HIGH	3-Pin, SOT23
FM810SES3 (Note 5)	10SE	2.93	32	Push-Pull, active HIGH	3-Pin, SOT23
FM810RES3 (Note 5)	10RE	2.63	32	Push-Pull, active HIGH	3-Pin, SOT23
FM810LFS3 (Note 5)	10LF	4.63	64	Push-Pull, active HIGH	3-Pin, SOT23
FM810MFS3 (Note 5)	10MF	4.38	64	Push-Pull, active HIGH	3-Pin, SOT23
FM810JFS3 (Note 5)	10JF	4.00	64	Push-Pull, active HIGH	3-Pin, SOT23
FM810TFS3 (Note 5)	10TF	3.08	64	Push-Pull, active HIGH	3-Pin, SOT23
FM810SFS3 (Note 5)	10SF	2.93	64	Push-Pull, active HIGH	3-Pin, SOT23
FM810RFS3 (Note 5)	10RF	2.63	64	Push-Pull, active HIGH	3-Pin, SOT23
FM810LHS3 (Note 5)	10LH	4.63	128	Push-Pull, active HIGH	3-Pin, SOT23
FM810MHS3 (Note 5)	10MH	4.38	128	Push-Pull, active HIGH	3-Pin, SOT23
FM810JHS3 (Note 5)	10JH	4.00	128	Push-Pull, active HIGH	3-Pin, SOT23
FM810THS3 (Note 5)	10TH	3.08	128	Push-Pull, active HIGH	3-Pin, SOT23
FM810SHS3 (Note 5)	10SH	2.93	128	Push-Pull, active HIGH	3-Pin, SOT23
FM810RHS3 (Note 5)	10RH	2.63	128	Push-Pull, active HIGH	3-Pin, SOT23

Note 5: These devices are available upon special request only. Please contact Fairchild sales for availability and minimum ordering requirements.

Physical Dimensions inches (millimeters) unless otherwise noted

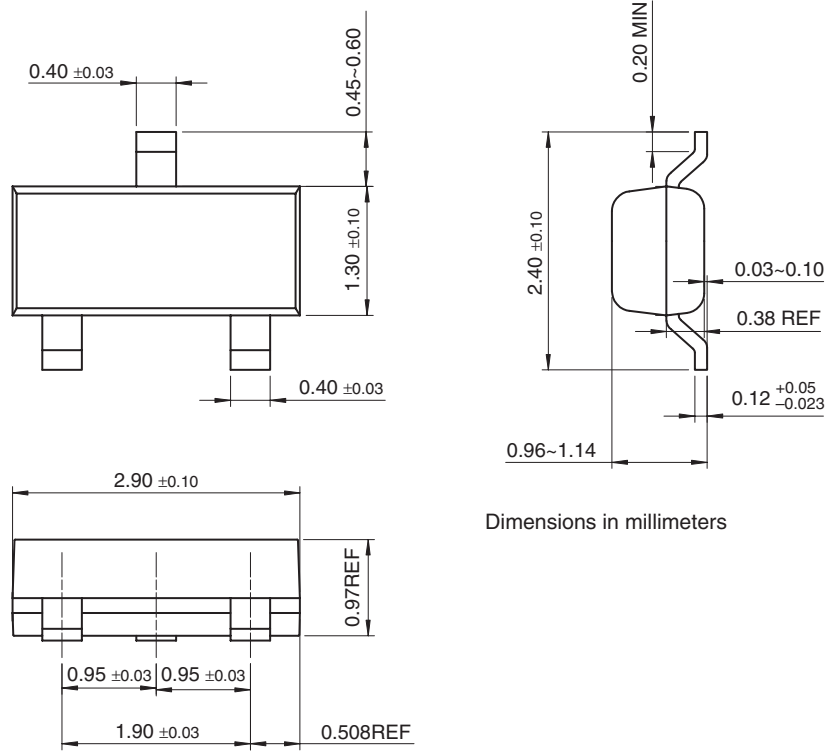

Dimensions in millimeters

**SOT-23 Package Dimensions
FS Pkg Code AU**

Life Support Policy

Fairchild's products are not authorized for use as critical components in life support devices or systems without the express written approval of the President of Fairchild Semiconductor Corporation. As used herein:

1. Life support devices or systems are devices or systems which, (a) are intended for surgical implant into the body, or (b) support or sustain life, and whose failure to perform, when properly used in accordance with instructions for use provided in the labeling, can be reasonably expected to result in a significant injury to the user.
2. A critical component is any component of a life support device or system whose failure to perform can be reasonably expected to cause the failure of the life support device or system, or to affect its safety or effectiveness.

**Fairchild Semiconductor
Americas
Customer Response Center**
Tel: 1-888-522-5372

**Fairchild Semiconductor
Europe**
Fax: +44 (0) 1793-856858
Deutsch Tel: +49 (0) 8141-6102-0
English Tel: +44 (0) 1793-856856
Français Tel: +33 (0) 1-6930-3696
Italiano Tel: +39 (0) 2-249111-1

**Fairchild Semiconductor
Hong Kong**
8/F, Room 808, Empire Centre
68 Mody Road, Tsimshatsui East
Kowloon, Hong Kong
Tel: +852-2722-8338
Fax: +852-2722-8383

**Fairchild Semiconductor
Japan Ltd.**
4F, Natsume Bldg.
2-18-6, Yushima, Bunkyo-ku
Tokyo, 113-0034 Japan
Tel: 81-3-3818-8840
Fax: 81-3-3818-8841

Fairchild does not assume any responsibility for use of any circuitry described, no circuit patent licenses are implied and Fairchild reserves the right at any time without notice to change said circuitry and specifications.