

RMPA0963 *i-Lo*™ Cellular CDMA, CDMA2000-1X and WCDMA Power Amplifier Module

Features

- 38% CDMA/WCDMA efficiency at +28 dBm Pout
- 14% CDMA/WCDMA efficiency (80 mA total current) at +16 dBm Pout
- Meets HSDPA performance requirements
- Linear operation in low-power mode up to +19 dBm
- 50% AMPS mode efficiency at +31 dBm Pout
- Low quiescent current (Iccq): 20 mA in low-power mode
- Single positive-supply operation with low power and shutdown modes
 - 3.4V typical Vcc operation
 - Low Vref (2.85V) compatible with advanced handset chipsets
- Compact Lead-free compliant LCC package – (4.0 X 4.0 x 1.5 mm nominal)
- Industry standard pinout
- Internally matched to 50 Ohms and DC blocked RF input/output
- Meets IS-95/CDMA2000-1XRTT/WCDMA performance requirements

General Description

The RMPA0963 Power Amplifier Module (PAM) is Fairchild's latest innovation in 50 Ohm matched, surface mount modules targeting Cellular CDMA/WCDMA/HSDPA, AMPS and Wireless Local Loop (WLL) applications. Answering the call for ultra-low DC power consumption and extended battery life in portable electronics, the RMPA0963 uses novel proprietary circuitry to dramatically reduce amplifier current at low to medium RF output power levels (< +16 dBm), where the handset most often operates. A simple two-state Vmode control is all that is needed to reduce operating current by more than 50% at 16 dBm output power, and quiescent current (Iccq) by as much as 70% compared to traditional power-saving methods. No additional circuitry, such as DC-to-DC converters, are required to achieve this remarkable improvement in amplifier efficiency. Further, the 4x4x1.5 mm LCC package is pin-compatible and a drop-in replacement for last generation 4x4 mm PAMs widely used today, minimizing the design time to apply this performance-enhancing technology. The multi-stage GaAs Microwave Monolithic Integrated Circuit (MMIC) is manufactured using Fairchild RF's InGaP Heterojunction Bipolar Transistor (HBT) process.

Device



Functional Block Diagram

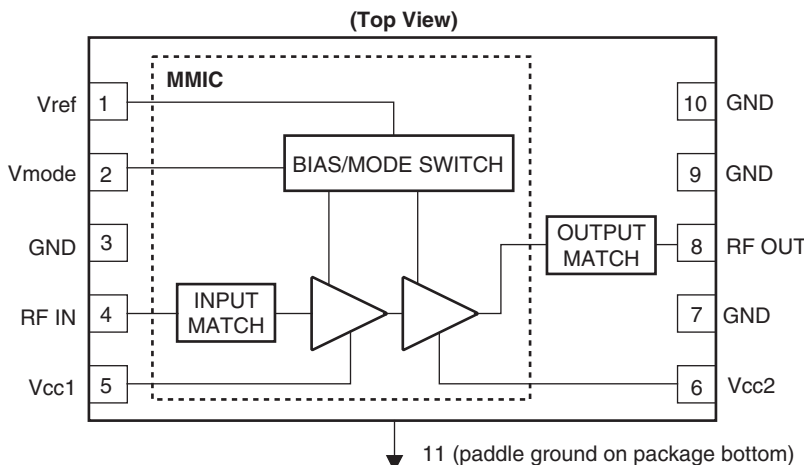

Absolute Maximum Ratings¹

Symbol	Parameter	Value	Units
Vcc1, Vcc2	Supply Voltages	5.0	V
Vref	Reference Voltage	2.6 to 3.5	V
Vmode	Power Control Voltage	3.5	V
Pin	RF Input Power	+10	dBm
Tstg	Storage Temperature	-55 to +150	°C

Note:

1. No permanent damage with one parameter set at extreme limit. Other parameters set to typical values.

Electrical Characteristics¹

Symbol	Parameter	Min	Typ	Max	Units	Comments
f	Operating Frequency	824		849	MHz	
CDMA/WCDMA Operation						
Gp	Power Gain		30 20		dB dB	Po=+28 dBm; Vmode=0V Po=+16 dBm; Vmode≥2.0V
Po	Linear Output Power	28 16			dBm dBm	Vmode=0V Vmode≥2.0V
PAEd	PAEd (digital) @ +28 dBm		38		%	Vmode=0V
	PAEd (digital) @ +16 dBm		14		%	Vmode≥2.0V
Itot	High Power Total Current		480		mA	Po=+28 dBm, Vmode=0V
	Low Power Total Current		80		mA	Po=+16 dBm, Vmode≥2.0V
CDMA	Adjacent Channel Power Ratio					IS-95 A/B Modulation
ACPR1	±885 KHz Offset		-50 -55		dBc dBc	Po=+28 dBm; Vmode=0V Po=+16 dBm; Vmode≥2.0V
			-60 -65		dBc dBc	Po=+28 dBm; Vmode=0V Po=+16 dBm; Vmode≥2.0V
ACPR2	±1.98 MHz Offset		-60 -65		dBc dBc	Po=+28 dBm; Vmode=0V Po=+16 dBm; Vmode≥2.0V
			-60 -65		dBc dBc	Po=+28 dBm; Vmode=0V Po=+16 dBm; Vmode≥2.0V
WCDMA	Adjacent Channel Leakage Ratio					WCDMA Modulation 3GPP 3.2 03-00 DPCCCH +1 DCDCCH
ACLR1	±5 MHz Offset		-40 -45		dBc dBc	Po=+28 dBm; Vmode=0V Po=+16 dBm; Vmode≥2.0V
			-53 -60		dBc dBc	Po=+28 dBm; Vmode=0V Po=+16 dBm; Vmode≥2.0V
ACLR2	±10 MHz Offset		-53 -60		dBc dBc	Po=+28 dBm; Vmode=0V Po=+16 dBm; Vmode≥2.0V
AMPS Operation						
Gp	Power Gain		29		dB	Po=+31 dBm
PAEa	Power-Added Efficiency (analog)		50		%	Po=+31 dBm
General Characteristics						
VSWR	Input Impedance		2.0:1	2.5:1		
NF	Noise Figure ³		4		dB	
Rx No	Receive Band Noise Power ³		-134		dBm/Hz	Po<+28 dBm; 869 to 894MHz
2fo-5fo	Harmonic Suppression ³			-30	dBc	Po≤+28 dBm
S	Spurious Outputs ^{2,3}			-60	dBc	Load VSWR≤5.0:1
	Ruggedness w/ Load Mismatch ³			10:1		No permanent damage.
Tc	Case Operating Temperature	-30		85	°C	
DC Characteristics						
Iccq	Quiescent Current		20		mA	Vmode≥2.0V
Iref	Reference Current		2		mA	Po+28 dBm
Icc(off)	Shutdown Leakage Current		1	5	µA	No applied RF signal

Notes:

- All parameters met at Tc = +25°C, Vcc = +3.4V, Vref = 2.85V and load VSWR ≤ 1.2:1, unless otherwise noted.
- All phase angles.
- Guaranteed by design.

Recommended Operating Conditions

Symbol	Parameter	Min	Typ	Max	Units
f	Operating Frequency	824		849	MHz
Vcc1, Vcc2	Supply Voltage	3.0	3.4	4.2	V
Vref	Reference Voltage (Operating) (Shutdown)	2.7	2.85	3.1	V
		0		0.5	V
Vmode	Bias Control Voltage (Low-Power) (High-Power)	1.8	2.0	3.0	V
		0		0.5	V
Pout	Linear Output Power (High-Power) (Low-Power)		+16	+28	dBm
				+19	dBm
Tc	Case Operating Temperature	-30		+85	°C

DC Turn-On Sequence

- 1) Vcc1 = Vcc2 = 3.4V (typical)
- 2) Vref = 2.85V (typical)
- 3) High-Power: Vmode = 0V (Pout > 16 dBm)
Low-Power: Vmode = 2V (Pout < 16 dBm)

Evaluation Board Layout

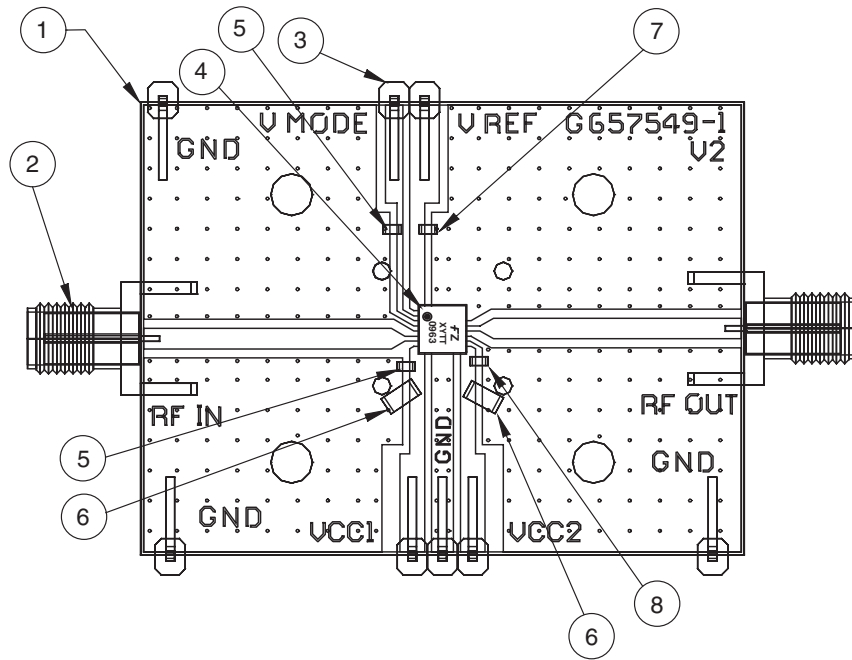

Materials List

Qty	Item No.	Part Number	Description	Vendor
1	1	G657549-1 V2	PC Board	Fairchild
2	2	#142-0701-841	SMA Connector	Johnson
8	3	#2340-5211TN	Terminals	3M
Ref	4	G657583	Assembly, RMPA0963	Fairchild
2	5	GRM39X7R102K50V	1000pF Capacitor (0603)	Murata
2	5 (Alt)	ECJ-1VB1H102K	1000pF Capacitor (0603)	Panasonic
2	6	C3216X5R1A335M	3.3µF Capacitor (1206)	TDK
1	7	GRM39Y5V104Z16V	0.1µF Capacitor (0603)	Murata
1	7 (Alt)	ECJ-1VB1C104K	0.1µF Capacitor (0603)	Panasonic
1	8	GRM39X7R331K50V	330pF Capacitor (0603)	Murata
A/R	9	SN63	Solder Paste	Indium Corp.
A/R	10	SN96	Solder Paste	Indium Corp.

Evaluation Board Schematic

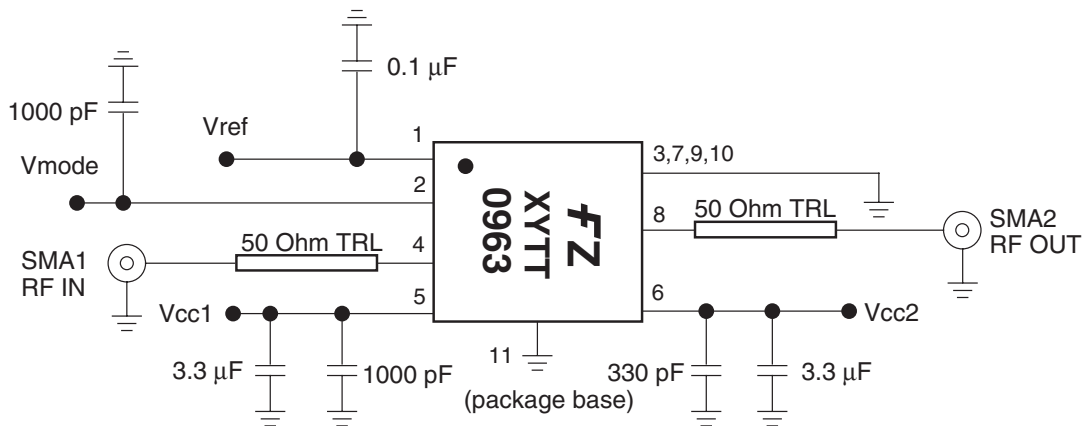

RMPA0963 i-Lo™ Cellular CDMA, CDMA2000-1X and WCDMA Power Amplifier Module (Preliminary)

Package Outline

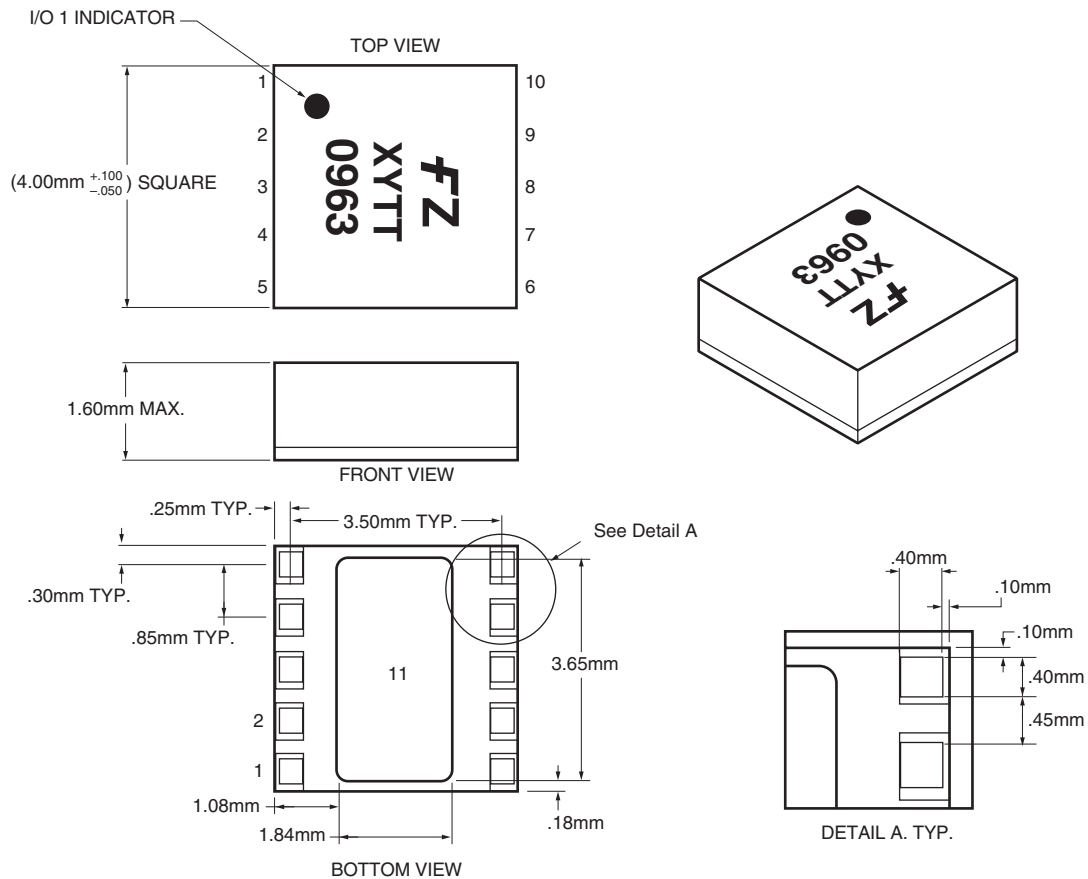

Signal Descriptions

Pin #	Signal Name	Description
1	Vref	Reference Voltage
2	Vmode	High Power/Low Power Mode Control
3	GND	Ground
4	RF In	RF Input Signal
5	Vcc1	Supply Voltage to Input Stage
6	Vcc2	Supply Voltage to Output Stage
7	GND	Ground
8	RF Out	RF Output Signal
9	GND	Ground
10	GND	Ground
11	GND	Paddle Ground

Application Information

CAUTION: THIS IS AN ESD SENSITIVE DEVICE

Precautions to Avoid Permanent Device Damage:

- Cleanliness: Observe proper handling procedures to ensure clean devices and PCBs. Devices should remain in their original packaging until component placement to ensure no contamination or damage to RF, DC & ground contact areas.
- Device Cleaning: Standard board cleaning techniques should not present device problems provided that the boards are properly dried to remove solvents or water residues.
- Static Sensitivity: Follow ESD precautions to protect against ESD damage:
 - A properly grounded static-dissipative surface on which to place devices.
 - Static-dissipative floor or mat.
 - A properly grounded conductive wrist strap for each person to wear while handling devices.
- General Handling: Handle the package on the top with a vacuum collet or along the edges with a sharp pair of bent tweezers. Avoiding damaging the RF, DC, & ground contacts on the package bottom. Do not apply excessive pressure to the top of the lid.
- Device Storage: Devices are supplied in heat-sealed, moisture-barrier bags. In this condition, devices are protected and require no special storage conditions. Once the sealed bag has been opened, devices should be stored in a dry nitrogen environment.

Device Usage:

Fairchild RF recommends the following procedures prior to assembly.

- Dry-bake devices at 125°C for 24 hours minimum. Note: The shipping trays cannot withstand 125°C baking temperature
- Assemble the dry-baked devices within 7 days of removal from the oven.
 - During the 7-day period, the devices must be stored in an environment of less than 60% relative humidity and a maximum temperature of 30°C
 - If the 7-day period or the environmental conditions have been exceeded, then the dry-bake procedure must be repeated.

Solder Materials & Temperature Profile:

- Reflow soldering is the preferred method of SMT attachment. Hand soldering is not recommended.

Reflow Profile

- Ramp-up: During this stage the solvents are evaporated from the solder paste. Care should be taken to prevent rapid oxidation (or paste slump) and solder bursts caused by violent solvent out-gassing. A typical heating rate is 1-2°C/sec.
- Pre-heat/soak: The soak temperature stage serves two purposes; the flux is activated and the board and devices achieve a uniform temperature. The recommended soak condition is: 120-150 seconds at 150°C.
- Reflow Zone: If the temperature is too high, then devices may be damaged by mechanical stress due to thermal mismatch or there may be problems due to excessive solder oxidation. Excessive time at temperature can enhance the formation of inter-metallic compounds at the lead/board interface and may lead to early mechanical failure of the joint. Reflow must occur prior to the flux being completely driven off. The duration of peak reflow temperature should not exceed 10 seconds. Maximum soldering temperatures should be in the range 215-220°C, with a maximum limit of 225°C.
- Cooling Zone: Steep thermal gradients may give rise to excessive thermal shock. However, rapid cooling promotes a finer grain structure and a more crack-resistant solder joint. The illustration below indicates the recommended soldering profile.
- Solder Joint Characteristics: Proper operation of this device depends on a reliable void-free attachment of the heatsink to the PWB. The solder joint should be 95% void-free and be a consistent thickness.
- Rework Considerations: Rework of a device attached to a board is limited to reflow of the solder with a heat gun. The device should not be subjected to more than 225°C and reflow solder in the molten state for more than 5 seconds. No more than 2 rework operations should be performed.

Recommended Solder Reflow Profile

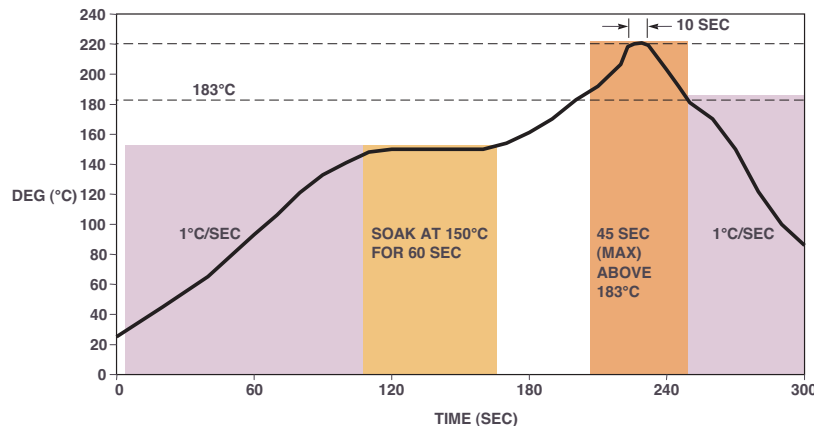

TRADEMARKS

The following are registered and unregistered trademarks Fairchild Semiconductor owns or is authorized to use and is not intended to be an exhaustive list of all such trademarks.

ACEx™	FAST	IntelliMAX™	POP™	SPM™
ActiveArray™	FASTr™	ISOPLANAR™	Power247™	Stealth™
Bottomless™	FPS™	LittleFET™	PowerEdge™	SuperFET™
CoolFET™	FRFET™	MICROCOUPLER™	PowerSaver™	SuperSOT™-3
CROSSVOLT™	GlobalOptoisolator™	MicroFET™	PowerTrench	SuperSOT™-6
DOMET™	GTO™	MicroPak™	QFET	SuperSOT™-8
EcoSPARK™	HiSeC™	MICROWIRE™	QS™	SyncFET™
E ² CMOS™	PC™	MSX™	QT Optoelectronics™	TinyLogic
EnSigna™	<i>i-Lo</i> ™	MSXPro™	Quiet Series™	TINYOPTO™
FACT™	ImpliedDisconnect™	OCX™	RapidConfigure™	TruTranslation™
FACT Quiet Series™		OCXPro™	RapidConnect™	UHC™
Across the board. Around the world.™		OPTOLOGIC	μSerDes™	UltraFET
The Power Franchise		OPTOPLANAR™	SILENT SWITCHER	UniFET™
Programmable Active Droop™		PACMAN™	SMART START™	VCX™

DISCLAIMER

FAIRCHILD SEMICONDUCTOR RESERVES THE RIGHT TO MAKE CHANGES WITHOUT FURTHER NOTICE TO ANY PRODUCTS HEREIN TO IMPROVE RELIABILITY, FUNCTION OR DESIGN. FAIRCHILD DOES NOT ASSUME ANY LIABILITY ARISING OUT OF THE APPLICATION OR USE OF ANY PRODUCT OR CIRCUIT DESCRIBED HEREIN; NEITHER DOES IT CONVEY ANY LICENSE UNDER ITS PATENT RIGHTS, NOR THE RIGHTS OF OTHERS.

LIFE SUPPORT POLICY

FAIRCHILD'S PRODUCTS ARE NOT AUTHORIZED FOR USE AS CRITICAL COMPONENTS IN LIFE SUPPORT DEVICES OR SYSTEMS WITHOUT THE EXPRESS WRITTEN APPROVAL OF FAIRCHILD SEMICONDUCTOR CORPORATION. As used herein:

1. Life support devices or systems are devices or systems which, (a) are intended for surgical implant into the body, or (b) support or sustain life, or (c) whose failure to perform when properly used in accordance with instructions for use provided in the labeling, can be reasonably expected to result in significant injury to the user.
2. A critical component is any component of a life support device or system whose failure to perform can be reasonably expected to cause the failure of the life support device or system, or to affect its safety or effectiveness.

PRODUCT STATUS DEFINITIONS**Definition of Terms**

Datasheet Identification	Product Status	Definition
Advance Information	Formative or In Design	This datasheet contains the design specifications for product development. Specifications may change in any manner without notice.
Preliminary	First Production	This datasheet contains preliminary data, and supplementary data will be published at a later date. Fairchild Semiconductor reserves the right to make changes at any time without notice in order to improve design.
No Identification Needed	Full Production	This datasheet contains final specifications. Fairchild Semiconductor reserves the right to make changes at any time without notice in order to improve design.
Obsolete	Not In Production	This datasheet contains specifications on a product that has been discontinued by Fairchild semiconductor. The datasheet is printed for reference information only.

Rev. 115