

# 240 Amp Schottky Rectifier HS246150

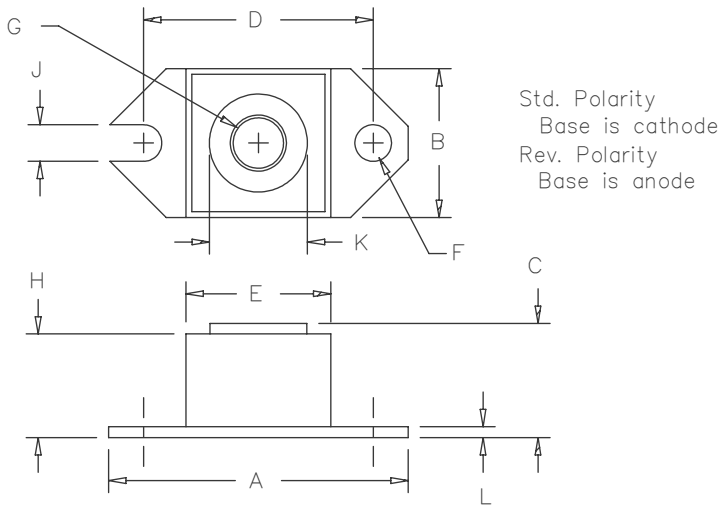

Dim.	Inches		Millimeter		Notes
	Minimum	Maximum	Minimum	Maximum	
A	1.52	1.56	38.61	39.62	
B	.725	.775	18.42	19.69	
C	.605	.625	15.37	15.88	
D	1.182	1.192	30.02	30.28	
E	.745	.755	18.92	19.18	Sq.
F	.152	.160	3.86	4.06	Dia.
G		1/4-20	UNC-2B		
H	.525	.580	13.34	14.73	
J	.156	.160	3.96	4.06	
K	.495	.505	12.57	12.83	Dia.
L	.120	.130	3.05	3.30	

Microsemi Catalog Number	Industry Part Number	Working Reverse Voltage	Peak Reverse Voltage	Repetitive Peak Reverse Voltage
HS246150*	249NQ150	150V	150V	150V

\*Add Suffix R for Reverse Polarity

- Schottky Barrier Rectifier
- Guard Ring Protection
- 240 Amperes 150 Volts
- 175°C Junction Temperature
- Reverse Energy Tested
- ROHS Compliant

## Electrical Characteristics

Average forward current	$I_F(AV)$ 240 Amps	$T_C = 118^\circ\text{C}$ , Square wave, $R_{\theta JC} = .24^\circ\text{C/W}$
Maximum surge current	$I_{FSM}$ 3300 Amps	8.3ms, half sine, $T_J = 175^\circ\text{C}$
Maximum repetitive reverse current	$I_{R(OV)}$ 2 Amps	$f = 1 \text{ KHZ}$ , $25^\circ\text{C}$
Typical peak forward voltage	$V_{FM}$ 0.65 Volts	$I_{FM} = 240\text{A}$ : $T_J = 175^\circ\text{C}^*$
Max peak forward voltage	$V_{FM}$ 0.86 Volts	$I_{FM} = 240\text{A}$ : $T_J = 25^\circ\text{C}^*$
Typical peak reverse current	$I_{RM}$ 150mA	$V_{RRM}$ , $T_J = 125^\circ\text{C}^*$
Max peak reverse current	$I_{RM}$ 8.0mA	$V_{RRM}$ , $T_J = 25^\circ\text{C}$
Typical junction capacitance	$C_J$ 6000pF	$V_R = 5.0\text{V}$ , $T_C = 25^\circ\text{C}$

\*Pulse test: Pulse width 300 $\mu\text{sec}$ , Duty cycle 2%

## Thermal and Mechanical Characteristics

Storage temp range	$T_{STG}$	$-55^\circ\text{C}$ to $175^\circ\text{C}$
Operating junction temp range	$T_J$	$-55^\circ\text{C}$ to $175^\circ\text{C}$
Max thermal resistance	$R_{\theta JC}$	$0.21^\circ\text{C/W}$ Junction to case
Typical thermal resistance (greased)	$R_{\theta CS}$	$0.12^\circ\text{C/W}$ Case to sink
Terminal Torque		35-40 inch pounds
Mounting Base Torque		20-25 inch pounds
Weight		1.1 ounces (32 grams) typical

# HS246150

Figure 1  
Typical Forward Characteristics

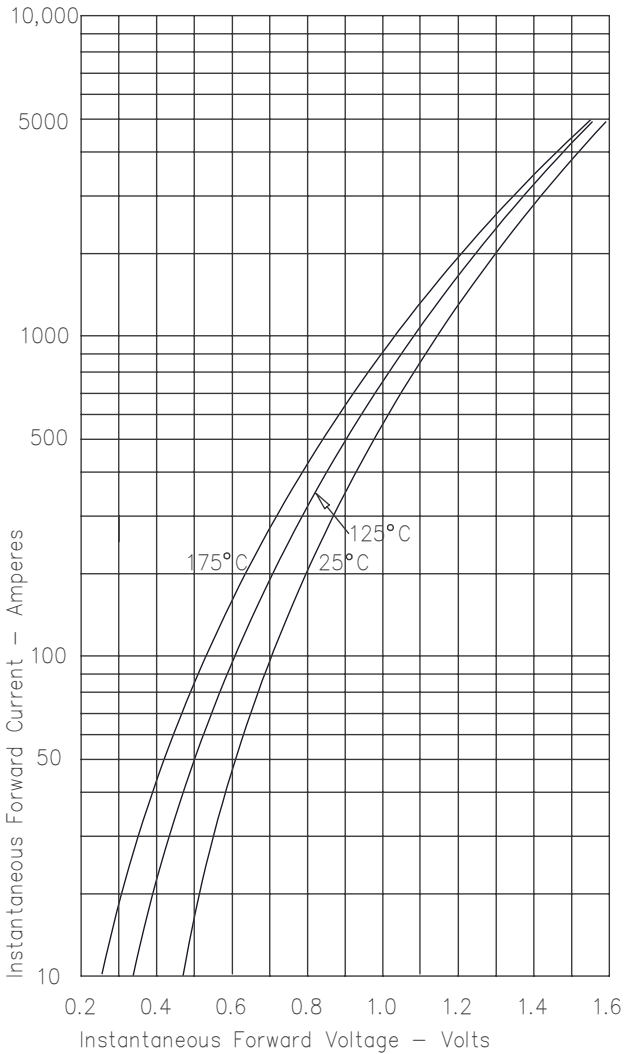

Figure 3  
Typical Junction Capacitance

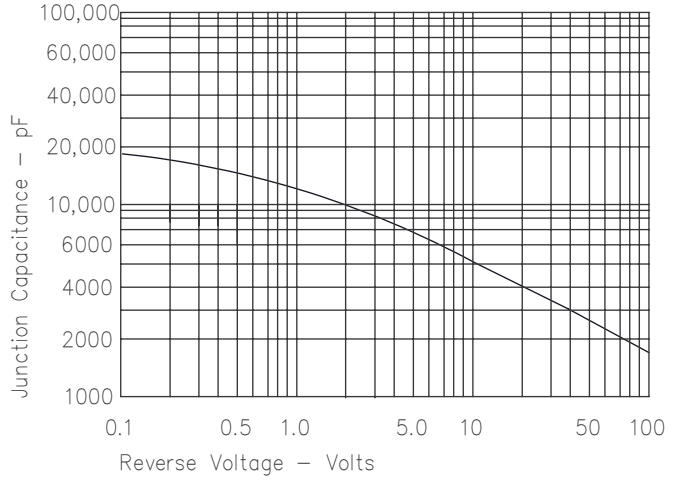

Figure 4  
Forward Current Derating

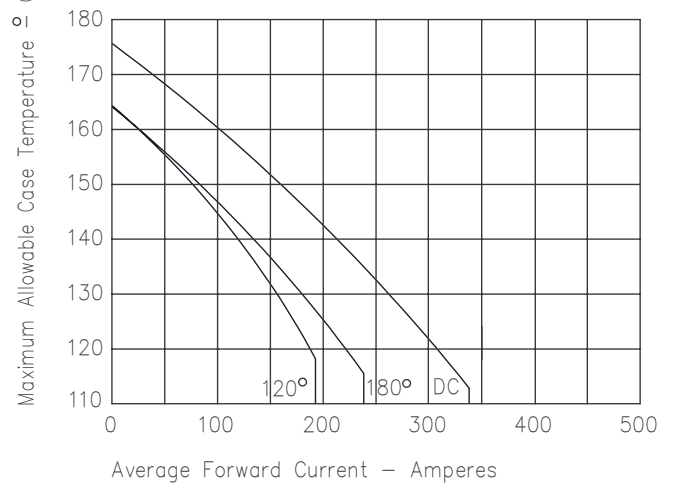

Figure 2  
Typical Reverse Characteristics

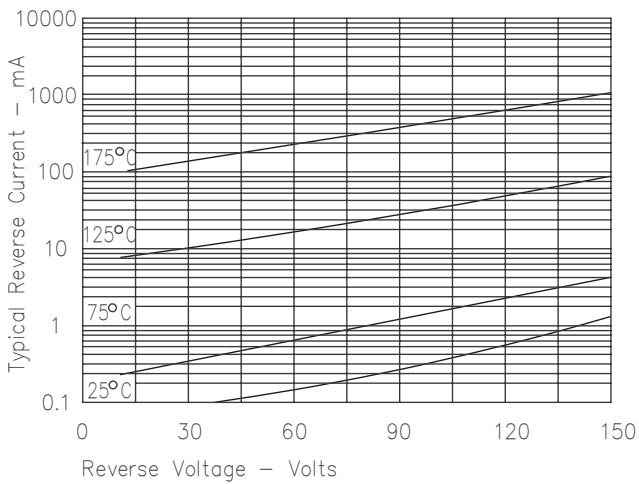

Figure 5  
Maximum Forward Power Dissipation

