

# 256Mb B-die NOR FLASH

---

56TSOP, 64FBGA, Page Mode  
2.7V ~ 3.6V

## datasheet

SAMSUNG ELECTRONICS RESERVES THE RIGHT TO CHANGE PRODUCTS, INFORMATION AND SPECIFICATIONS WITHOUT NOTICE.

Products and specifications discussed herein are for reference purposes only. All information discussed herein is provided on an "AS IS" basis, without warranties of any kind.

This document and all information discussed herein remain the sole and exclusive property of Samsung Electronics. No license of any patent, copyright, mask work, trademark or any other intellectual property right is granted by one party to the other party under this document, by implication, estoppel or otherwise.

Samsung products are not intended for use in life support, critical care, medical, safety equipment, or similar applications where product failure could result in loss of life or personal or physical harm, or any military or defense application, or any governmental procurement to which special terms or provisions may apply.

For updates or additional information about Samsung products, contact your nearest Samsung office.

All brand names, trademarks and registered trademarks belong to their respective owners.

© 2010 Samsung Electronics Co., Ltd. All rights reserved.

## Revision History

<u>Revision No.</u>	<u>History</u>	<u>Draft Date</u>	<u>Remark</u>	<u>Editor</u>
0.0	Initial draft	Mar.03,2008	Target	-
0.1	<p>Description of Hardwre Protection in Figure 8: Enhanced Block Protection/Unprotection is changed from "A outermost block on both ends of flash array locked" to "Highest or lowest block locked"</p> <p>DC Characteristics Table is revised.</p> <ul style="list-style-type: none"> <li>- "Read While Program Current"(I2) and "Read While Erase Current"(I3) are deleted.</li> <li>- "WP/ACC Input Leakage Current" is changed to "A9 Input Leakage Current".</li> <li>- "Active Write Current " is changed to " Vcc Active Read Current".</li> <li>- "V<sub>IO</sub> Non-Active Output", I<sub>IO2</sub> is added.</li> <li>- "Voltage for <math>\overline{WP}</math>/ACC Block Temporarily Unprotect and Program Acceleration" is changed to "Voltage for Program Acceleration ".</li> <li>- "Voltage for Autoselect and Temporary Sector Unprotect", V<sub>ID</sub> is added.</li> </ul> <p>FEATURE is revised.</p> <ul style="list-style-type: none"> <li>- "Read While Program/Erase Operation" is deleted.</li> <li>- "Read While Program or Read While Erase Current : 55mA " is deleted.</li> </ul> <p>Figure : Write Buffer Program Command Sequence is revised.</p> <p>CFI Table is revised.</p> <ul style="list-style-type: none"> <li>- Address 30H data changed from 0001H to 0002H.</li> <li>- Address 34H data changed from 0004H to 0000H.</li> </ul>	May.15,2008	Target	-
0.2	<p>FEATURE is revised.</p> <ul style="list-style-type: none"> <li>- 64Mbitx256 is changed to 64Kwordx256.</li> </ul>	June 12, 2008	Target	-
0.3	<ul style="list-style-type: none"> <li>- 64FBGA Package Demension is added.</li> <li>- Endurance is added.</li> <li>- Indicator Bit Codes table description is corrected</li> </ul>	June 27, 2008	Target	-
0.4	<ul style="list-style-type: none"> <li>- "The data is DQ6 = "1" for customer locked and DQ7 = "1" for factory locked." is changed to " The DQ7 is "1" for factory locked."</li> <li>- Device ID data is revised from 227EH, 2264H and 2260H to XX7EH, XX64H and XX60H on Command Sequences(x8) table.</li> <li>- Byte Mode Address is added to CFI table.</li> </ul> <p>CFI Table is revised.</p> <ul style="list-style-type: none"> <li>- Address 38H data changed from 0001H to 0000H.</li> <li>- "Blocks must be unprotected before raising <math>\overline{WP}</math>/ACC to V<sub>HH</sub>. " is added to accelerated program operation.</li> <li>- "When the <math>\overline{WP}</math>/ACC pin is asserted as V<sub>HH</sub>, the device automatically enters the Unlock Bypass mode, temporarily unprotecting any protected blocks, and reduces the program operation time." is changed to "When the <math>\overline{WP}</math>/ACC pin is asserted as V<sub>HH</sub>, the device automatically enters the Unlock Bypass mode, and reduces the program operation time. "</li> <li>- 64FBGA Package Demension is revised.</li> <li>- Ordering Information is revised.</li> </ul>	July 04,2008	Target	-
1.0	<ul style="list-style-type: none"> <li>- Deleted speed code for 4C / 4D.</li> <li>- AC parameter table for speed code 4C and 4D is deleted.</li> <li>- Min. VIH DC value is changed from 2.0V to VCC x 0.7V.</li> <li>- ICC6 is changed from Typ. 6mA and Max. 10mA to Typ. 10mA and Max. 15mA</li> </ul>	Dec. 11, 2008	Final	-

1.1	- NOTE is deleted. Related NOTE is below. <b>NOTE :</b> The device supports only 4E at VIO = 1.7~1.95V. - Package dimension of 56-TSOP is revised.	Apr. 02, 2009	Final	-
1.2	- Revised Hardware Sequence Flags Table. - Deleted DQ6 as Customer OTP Lock information in 12. OTP Block Region.	Jun. 02, 2009	Final	-
1.3	- Correct typo	May 12, 2010	Final	-

[Table Of Contents](#)[256Mb B-die NOR FLASH](#)

1.0 FEATURES .....	5
2.0 GENERAL DESCRIPTION .....	5
3.0 PIN DESCRIPTION .....	6
4.0 56TSOP PIN CONFIGURATION .....	7
5.0 64 Ball FBGA TOP VIEW (BALL DOWN) .....	7
6.0 FUNCTIONAL BLOCK DIAGRAM .....	8
7.0 ORDERING INFORMATION .....	9
8.0 PRODUCT INTRODUCTION .....	10
9.0 COMMAND DEFINITIONS .....	11
10.0 DEVICE OPERATION .....	16
10.1 Read Mode .....	16
10.2 Standby Mode .....	16
10.3 Output Disable .....	16
10.4 Automatic Sleep Mode .....	16
10.5 Autoselect Mode .....	16
10.6 Write (Program/Erase) Mode .....	17
10.6.1 Program .....	17
10.6.2 Writer Buffer Programming .....	18
10.6.3 Accelerated Program Operation .....	19
10.6.4 Unlock Bypass .....	20
10.6.5 Chip Erase .....	20
10.6.6 Block Erase .....	20
10.7 Erase Suspend / Resume .....	21
10.8 Program Suspend / Resume .....	21
10.9 Write Protect (WP) .....	22
10.10 Software Reset .....	22
10.11 Hardware Reset .....	22
10.12 Power-up Protection .....	23
10.13 Low Vcc Write Inhibit .....	23
10.14 Write Pulse Glitch Protection .....	23
10.15 Logical Inhibit .....	23
11.0 COMMON FLASH MEMORY INTERFACE .....	24
12.0 OTP Block Region .....	24
12.1 OTP Block Protection .....	24
13.0 ENHANCED BLOCK PROTECTION / UNPROTECTION .....	25
13.1 Block Protection .....	26
13.1.1 Lock Register .....	26
13.2 Persistent Protection Bits .....	26
13.3 Dynamic Protection Bits .....	27
13.4 Persistent Protection Bit Lock Bit .....	27
13.5 Password Protection Method .....	27
13.6 Master locking bit set .....	28
14.0 DEVICE STATUS FLAGS .....	36
15.0 ABSOLUTE MAXIMUM RATINGS .....	39
16.0 RECOMMENDED OPERATING CONDITIONS ( Voltage reference to GND ) .....	39
17.0 DC CHARACTERISTICS .....	40
17.1 CAPACITANCE (TA = 25 °C, VCC = 3.0V, f = 1.0MHz) .....	40
18.0 AC TEST CONDITION .....	41
19.0 AC CHARACTERISTICS .....	41
19.1 Read Operations .....	41
19.2 Write(Erase/Program)Operations .....	44
20.0 ERASE AND PROGRAM PERFORMANCE .....	45
21.0 PACKAGE DIMENSIONS .....	58

**256M Bit (16M x16, 32Mb x8) Page Mode / Page NOR Flash Memory****1.0 FEATURES**

- Single Voltage, 2.7V to 3.6V for Read and Write operations
- Organization
  - 16M x16 bit (Word mode)
  - 32M x 8 bit (Byte mode)
- Fast Read Access Time : 80ns
- Page Mode Operation
  - 8 Words Page access allows fast asynchronous read
  - Page Read Access Time : 30ns
- Uniform block architectures
  - 64Kword x 256 (Uniform)
- OTP Block : Extra 256 word
  - 128word for factory and 128word for customer OTP
- Power Consumption (typical value)
  - Active Read Current : 30mA (@5MHz)
  - Program/Erase Current : 25mA
  - Standby Mode/Auto Sleep Mode : 20uA
- Support Single & 32word Buffer Program
- WP/ACC input pin
  - Allows special protection of first or last block of flash array at V<sub>L</sub>, regardless of block protect status
  - Removes special protection at V<sub>H</sub>, the first or last block of flash array return to normal block protect status
  - Reduce program time at V<sub>H</sub> : 6us/word at Write Buffer
- Erase Suspend/Resume
- Program Suspend/Resume
- Unlock Bypass Mode
- Hardware RESET Pin
- Command Register Operation
- Supports Common Flash Memory Interface
- Industrial Temperature : -40°C to 85°C
- Extended Temperature : -25°C to 85°C
- Endurance : 100Kcycle
- Vio options at 1.8V and 3V I/O
- Package options
  - 56 Pin TSOP (20x14mm)
  - 64 Ball FBGA (11x13, 1.0mm Ball Pitch)

**2.0 GENERAL DESCRIPTION**

The K8P5516UZH featuring single 3.0V power supply, is an 256Mbit NOR-type Flash Memory organized as 32M x 8 or 16M x16. The memory architecture of the device is designed to divide its memory arrays into 256 blocks with independent hardware protection. This block architecture provides highly flexible erase and program capability. The K8P5516UZH NOR Flash consists of uniform block.

The K8P5516UZH offers page access time of 30ns with random access time of 80ns. The device's fast access times allow high speed microprocessors to operate without wait states. The device performs a program operation in unit of 16 bits (Word) and erases in units of a block. Single or multiple blocks can be erased. The block erase operation is completed within typically 0.7 sec. The device requires 25mA as program/erase current in the commercial and extended temperature ranges.

The K8P5516UZH NOR Flash Memory is created by using Samsung's advanced CMOS process technology. This device is available in 64FBGA and 56 Pin TSOP. The device is compatible with EPROM applications to require high-density and cost-effective nonvolatile read/write storage solutions.

### 3.0 PIN DESCRIPTION

Pin Name	Pin Function
A0 - A23	Address Inputs
DQ0 - DQ14	Data Inputs / Outputs
DQ15/A-1	DQ15 - Data Inputs / Outputs in word mode A-1 - Address input in byte mode
CE	Chip Enable
OE	Output Enable
RESET	Hardware Reset Pin
BYTE	Word/Byte selection
RY/ $\overline{\text{BY}}$	Ready/Busy Output
WE	Write Enable
WP/ACC	Hardware Write Protection/Program Acceleration
Vcc	Power Supply
Vss	Ground
NC	No Connection

### 4.0 56TSOP PIN CONFIGURATION

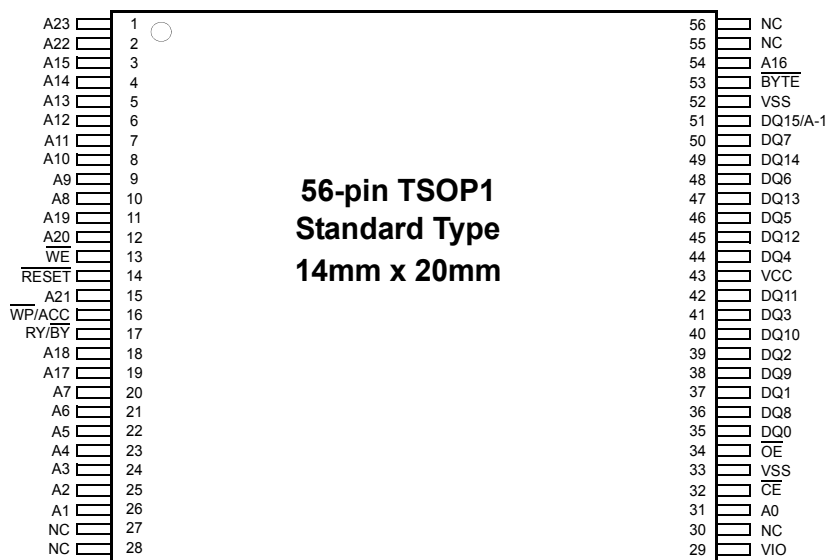

### 5.0 64 Ball FBGA TOP VIEW (BALL DOWN)

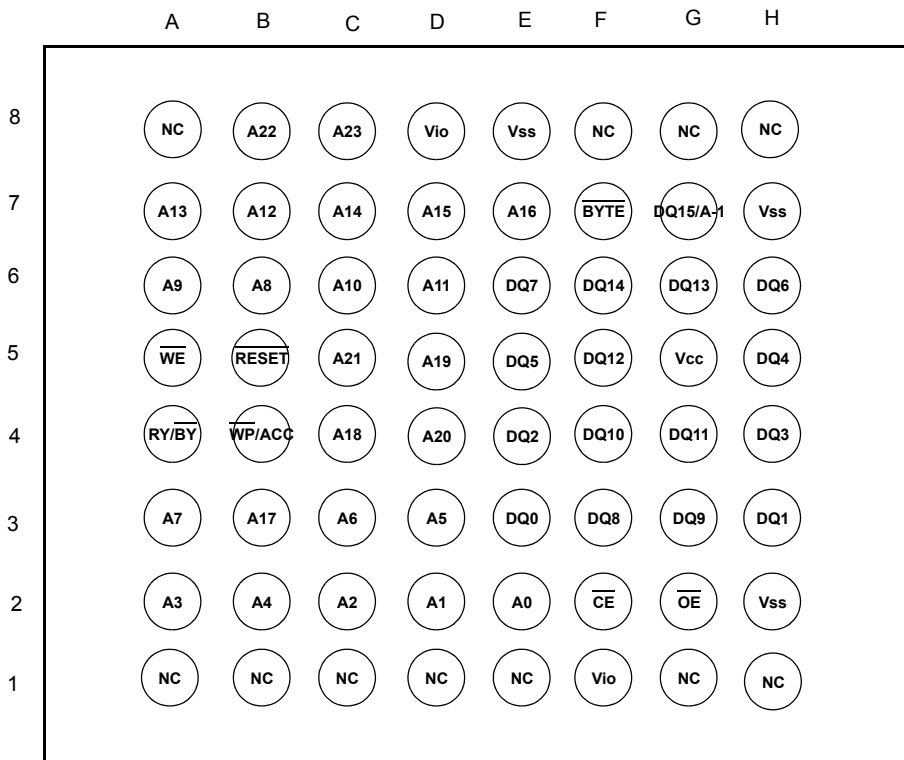

### 6.0 FUNCTIONAL BLOCK DIAGRAM

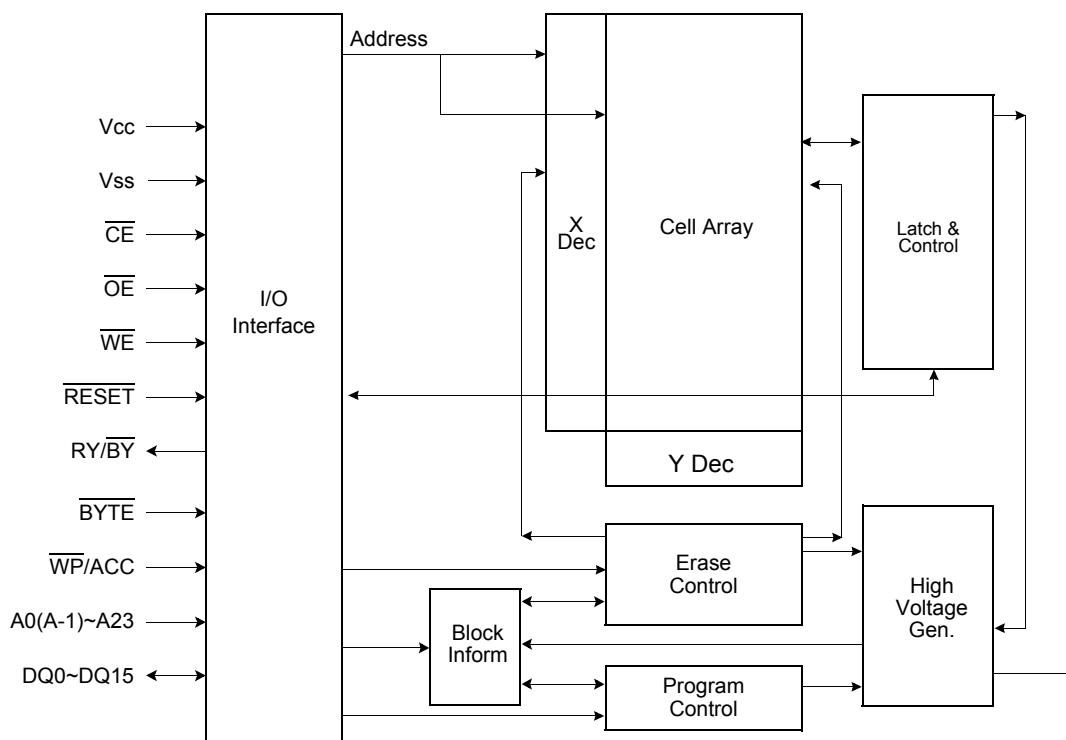



## 7.0 ORDERING INFORMATION

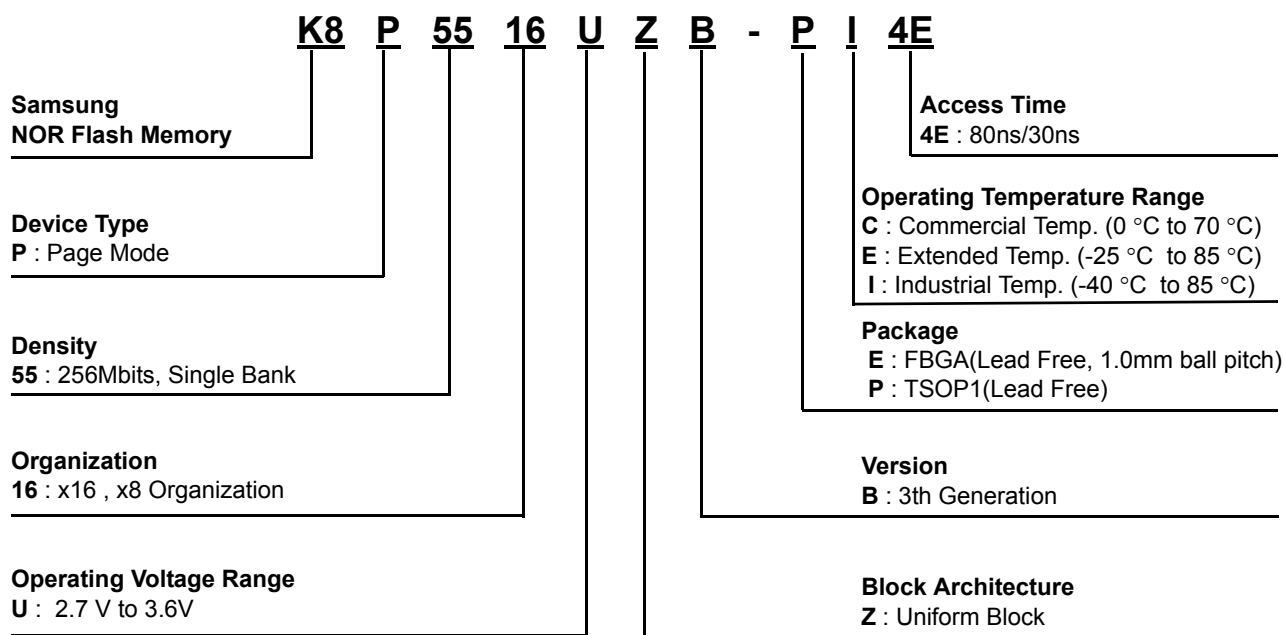

[Table 1] PRODUCT LINE-UP

	4E
Vcc	2.7V~3.6V
VIO	1.7V~Vcc
Max. Address Access Time (ns)	80ns
Max. $\overline{CE}$ Access Time (ns)	80ns
Max. $\overline{OE}$ Access Time (ns)	30ns
Max. Page Access Time (ns)	30ns

[Table 2] K8P5516UZB DEVICE BLOCK DIVISIONS

Mbit	Block Sizes
256 Mbit	64 Kw x 256

[Table 3] OTP BLOCK

OTP	Block Address A23~A8	Area	Block Size	Address Range
	0000h	Factory-Locked Area	128 words	000000h-00007Fh
		Customer-Locked Area	128 words	000080h-0000FFh

After entering OTP block, any issued addresses should be in the range of OTP block address

## 8.0 PRODUCT INTRODUCTION

The K8P5516UZH is 256Mbit NOR-type Flash memory. The device features single voltage power supply operating within the range of 2.7V to 3.6V. The device is programmed by using the Channel Hot Electron (CHE) injection mechanism which is used to program EPROMs. The device is erased electrically by using Fowler-Nordheim tunneling mechanism. To provide highly flexible erase and program capability, the device adapts a block memory architecture that divides its memory array into 256 blocks (64 Kw x 256). Programming is done in units of 16 bits (Word) or 8 bits (Byte). All bits of data in one or multiple blocks can be erased simultaneously when the device executes the erase operation. The device offers page access time of 30ns with random access time of 80ns supporting high speed microprocessors to operate without any wait states.

The command set of K8P5516UZH is fully compatible with standard Flash devices. The device is controlled by chip enable ( $\overline{CE}$ ), output enable ( $\overline{OE}$ ) and write enable ( $\overline{WE}$ ). Device operations are executed by selective command codes. The command codes to be combined with addresses and data are sequentially written to the command registers using microprocessor write timing. The command codes serve as inputs to an internal state machine which controls the program/erase circuitry. Register contents also internally latch addresses and data necessary to execute the program and erase operations. The K8P5516UZH is implemented with Internal Program/Erase Algorithms to execute the program/erase operations. The Internal Program/Erase Algorithms are invoked by program/erase command sequences. The Internal Program Algorithm automatically programs and verifies data at specified addresses. The Internal Erase Algorithm automatically pre-programs the memory cell which is not programmed and then executes the erase operation. The K8P5516UZH has means to indicate the status of completion of program/erase operations. The status can be indicated via the RY/BY pin, Data polling of DQ7, or the Toggle bit (DQ6). Once the operations have been completed, the device automatically resets itself to the read mode.

[Table 4] Operations Table

Operation	$\overline{CE}$	$\overline{OE}$	$\overline{WE}$	$\overline{WP/ACC}$	A0(A-1) ~ A23	DQ0 ~ DQ7	DQ8 ~ DQ15		$\overline{RESET}$
							$\overline{BYTE} = V_{IH}$	$\overline{BYTE} = V_{IL}$	
Read	L	L	H	X	A <sub>IN</sub>	DOUT	DOUT	DQ8 ~ 14 = High-z DQ15 = A-1	H
Stand-by	V <sub>cc</sub> ±0.3V	X	X	H	X	High-Z	High-Z	High-Z	V <sub>cc</sub> ±0.3V
Output Disable	L	H	H	X	X	High-Z	High-Z	High-Z	H
Reset	X	X	X	X	X	High-Z	High-Z	High-Z	L
Write	L	H	L	X <sup>1)</sup>	A <sub>IN</sub>	DIN	DIN	DQ8 ~ 14 = High-z DQ15 = A-1	H

L = V<sub>IL</sub> (Low), H = V<sub>IH</sub> (High), A<sub>IN</sub> = Address in, D<sub>IN</sub> = Data in, D<sub>OUT</sub> = Data out, X = Don't care.

**NOTE :**

1)  $\overline{WP/ACC}$  must be V<sub>IH</sub> when writing on the outermost block. (BA0 or BA255)

2) Address for word mode is AMax:0.

Address for byte mode is AMax:A-1.

## 9.0 COMMAND DEFINITIONS

The K8P5516UZB operates by selecting and executing its operational modes. Each operational mode has its own command set. In order to select a certain mode, a proper command with specific address and data sequences must be written into the command register. Writing incorrect information which include address and data or writing an improper command will reset the device to the read mode. The defined valid register command sequences are stated in Table 5.

[Table 5] Command Sequences (x16)

Command Sequence		Cycle	1st Cycle	2nd Cycle	3rd Cycle	4th Cycle	5th Cycle	6th Cycle
Read	Addr	1	RA					
	Data		RD					
Reset	Addr	1	XXXH					
	Data		F0H					
Autoselect Manufacturer ID 1), 2)	Addr	4	555H	2AAH	555H	X00H		
	Data		AAH	55H	90H	ECH		
Autoselect Device ID 1), 2), 3)	Addr	6	555H	2AAH	555H	X01H	X0EH	X0FH
	Data		AAH	55H	90H	227EH	2264H	2260H
Autoselect Block Protect Ver- ify 1), 2)	Addr	4	555H	2AAH	555H	BA / X02H		
	Data		AAH	55H	90H	(See Table 7)		
Autoselect Indicator Bit 1), 2)	Addr	4	555H	2AAH	555H	X03H		
	Data		AAH	55H	90H	(See Table 7)		
Autoselect Master Locking Bit 1), 2)	Addr	4	555H	2AAH	555H	X07H		
	Data		AAH	55H	90H	(See Table 7)		
Program	Addr	4	555H	2AAH	555H	PA		
	Data		AAH	55H	A0H	PD		
Write to Buffer 4)	Addr	6	555H	2AAH	BA	BA	WBL	WBL
	Data		AAH	55H	25H	WC	PD	PD
Program Buffer to Flash	Addr	1	BA					
	Data		29H					
Write to Buffer Abort Reset 4)	Addr	3	555H	2AAH	555H			
	Data		AAH	55H	F0H			
Unlock Bypass	Addr	3	555H	2AAH	555H			
	Data		AAH	55H	20H			
Unlock Bypass Program	Addr	2	XXXH	PA				
	Data		A0H	PD				
Unlock Bypass Block Erase	Addr	2	XXXH	BA				
	Data		80H	30H				
Unlock Bypass Chip Erase	Addr	2	XXXH	XXXH				
	Data		80H	10H				
Unlock Bypass Reset	Addr	2	XXXH	XXXH				
	Data		90H	00H				
Chip Erase	Addr	6	555H	2AAH	555H	555H	2AAH	555H
	Data		AAH	55H	80H	AAH	55H	10H
Block Erase	Addr	6	555H	2AAH	555H	555H	2AAH	BA
	Data		AAH	55H	80H	AAH	55H	30H
Block Erase Suspend 5), 6)	Addr	1	XXXH					
	Data		B0H					
Block Erase Resume	Addr	1	XXXH					
	Data		30H					

Command Definitions		Cycle	1st Cycle	2nd Cycle	3rd Cycle	4th Cycle	5th Cycle	6th Cycle
Program Suspend <sup>7), 8)</sup>	Addr	1	XXXH					
	Data		B0H					
Program Resume	Addr	1	XXXH					
	Data		30H					
CFI Query <sup>9)</sup>	Addr	1	X55H					
	Data		98H					
Enter OTP Block Region	Addr	3	555H	2AAH	555H			
	Data		AAH	55H	88H			
OTP Block Program	Addr	4	555H	2AAH	555H	PA		
	Data		AAH	55H	A0H	PD		
OTP Block Read	Addr	1	RA					
	Data		RD					
Exit OTP Block Region	Addr	4	555H	2AAH	555H	XXXH		
	Data		AAH	55H	90H	00H		

**NOTE :**

- RA : Read Address, PA : Program Address, RD : Read Data, PD : Program Data, WBL : Write Buffer Location
- BA : Block Address (A16 - A23), ABP : Address of the block to be protected or unprotected, X = Don't care .
- DQ8 - DQ15 are don't care in command sequence, except for RD and PD
- A14 - A23 are also don't care, except for the case of special notice.

1) To terminate the Autoselect Mode, it is necessary to write Reset command to the register.

2) The 4th cycle data of Autoselect mode is output data.

3) Device ID must be read across cycles 4, 5 and 6.

Device ID data : X0EH = "2264H", X0FH = "2260H" for 256Mb Uniform Block Device

4) Command sequence resets device for next command after write-to-buffer operation.

5) The Read / Program operations at non-erasing blocks and the autoselect mode are allowed in the Erase Suspend mode.

6) The Erase Suspend command is applicable only to the Block Erase operation.

7) The Read Operation is allowed in the Program Suspend mode.

8) The Program Suspend command is applicable to Program and Erase Suspend - Program operation.

9) Command is valid when the device is in read mode or Autoselect mode.

[Table 6] Table 5 : Command Sequences (x8)

Command Sequence		Cycle	1st Cycle	2nd Cycle	3rd Cycle	4th Cycle	5th Cycle	6th Cycle
Read	Addr	1	RA					
	Data		RD					
Reset	Addr	1	XXXH					
	Data		F0H					
Autoselect Manufacturer ID <sup>1), 2)</sup>	Addr	4	AAAH	555H	AAAH	X00H		
	Data		AAH	55H	90H	ECH		
Autoselect Device ID <sup>1), 2), 3)</sup>	Addr	6	AAAH	555H	AAAH	X02H	X1CH	X1EH
	Data		AAH	55H	90H	XX7EH	XX64H	XX60H
Autoselect Block Protect Verify <sup>1), 2)</sup>	Addr	4	AAAH	555H	AAAH	BA / X04H		
	Data		AAH	55H	90H	(See Table 7)		
Autoselect Indicator Bit <sup>1), 2)</sup>	Addr	4	AAAH	555H	AAAH	X06H		
	Data		AAH	55H	90H	(See Table 7)		
Program	Addr	4	AAAH	555H	AAAH	PA		
	Data		AAH	55H	A0H	PD		
Write to Buffer <sup>4)</sup>	Addr	6	AAAH	555H	BA	BA	WBL	WBL
	Data		AAH	55H	25H	WC	PD	PD
Program Buffer to Flash	Addr	1	BA					
	Data		29H					
Write to Buffer Abort Reset <sup>4)</sup>	Addr	3	AAAH	555H	555H			
	Data		AAH	55H	F0H			
Unlock Bypass	Addr	3	AAAH	555H	AAAH			
	Data		AAH	55H	20H			
Unlock Bypass Program	Addr	2	XXXH	PA				
	Data		A0H	PD				
Unlock Bypass Block Erase	Addr	2	XXXH	BA				
	Data		80H	30H				
Unlock Bypass Chip Erase	Addr	2	XXXH	XXXH				
	Data		80H	10H				
Unlock Bypass Reset	Addr	2	XXXH	XXXH				
	Data		90H	00H				
Chip Erase	Addr	6	AAAH	555H	AAAH	AAAH	555H	AAAH
	Data		AAH	55H	80H	AAH	55H	10H
Block Erase	Addr	6	AAAH	555H	AAAH	AAAH	555H	BA
	Data		AAH	55H	80H	AAH	55H	30H
Block Erase Suspend <sup>5), 6)</sup>	Addr	1	XXXH					
	Data		B0H					
Block Erase Resume	Addr	1	XXXH					
	Data		30H					

Command Definitions		Cycle	1st Cycle	2nd Cycle	3rd Cycle	4th Cycle	5th Cycle	6th Cycle
Program Suspend <sup>7), 8)</sup>	Addr	1	XXXH					
	Data		B0H					
Program Resume	Addr	1	XXXH					
	Data		30H					
CFI Query <sup>9)</sup>	Addr	1	AAH					
	Data		98H					
Enter OTP Block Region	Addr	3	AAAH	555H	AAAH			
	Data		AAH	55H	88H			
OTP Block Program	Addr	4	AAAH	555H	AAAH	PA		
	Data		AAH	55H	A0H	PD		
OTP Block Read	Addr	1	RA					
	Data		RD					
Exit OTP Block Region	Addr	4	AAAH	555H	AAAH	XXXH		
	Data		AAH	55H	90H	00H		

**NOTE :**

- RA : Read Address, PA : Program Address, RD : Read Data, PD : Program Data, WBL : Write Buffer Location
- BA : Block Address (A16 - A23), ABP : Address of the block to be protected or unprotected, X = Don't care .
- DQ8 - DQ15 are don't care in command sequence, except for RD and PD
- A14 - A23 are also don't care, except for the case of special notice.

1) To terminate the Autoselect Mode, it is necessary to write Reset command to the register.

2) The 4th cycle data of Autoselect mode is output data.

3) Device ID must be read across cycles 4, 5 and 6.

Device ID data : X0EH = "2264H", X0FH = "2260H" for 256Mb Top and Boot Block Device

4) Command sequence resets device for next command after write-to-buffer operation.

5) The Read / Program operations at non-erasing blocks and the autoselect mode are allowed in the Erase Suspend mode.

6) The Erase Suspend command is applicable only to the Block Erase operation.

7) The Read Operation is allowed in the Program Suspend mode.

8) The Program Suspend command is applicable to Program and Erase Suspend - Program operation.

9) Command is valid when the device is in read mode or Autoselect mode.

[Table 7] K8P5516UZB Autoselect Codes

		$\overline{\text{CE}}$	$\overline{\text{OE}}$	$\overline{\text{WE}}$	A23 - A16	A15 - A10	A8 ~ A7	A6	A5 ~ A4	A3	A2	A1	A0	DQ15 - DQ8		DQ7 - DQ0
														BYTE = V <sub>IH</sub>	BYTE = V <sub>IL</sub>	
Manufacturer ID		L	L	H	X	X	X	L	X	L	L	L	L	X	X	ECH
Device ID	Read Cycle1	L	L	H	X	X	X	L	X	L	L	L	H	22H	X	7EH
	Read Cycle2	L	L	H	X	X	X	L	X	H	H	H	L	22H	X	64H
	Read Cycle3	L	L	H	X	X	X	L	X	H	H	H	H	22H	X	60H
Block Protection Verification		L	L	H	BA	X	X	L	X	L	L	H	L	X	X	01H : (Protected : Either DYB or PPB locked)
Indicator Bit(2)		L	L	H	X	X	X	L	X	L	L	H	H	X	X	99H : Factory Locked, Highest block controlled by $\overline{\text{WP}}$ 19H : NOT Factory Locked, Highest block controlled by $\overline{\text{WP}}$ 89H : Factory Locked, Lowest block controlled by $\overline{\text{WP}}$ 09H : NOT Factory Locked, Lowest block controlled by $\overline{\text{WP}}$ DQ7 : Factory Lock Bit
Master locking bit Indicator Bit		L	L	H	BA	X	L	L	L	L	H	H	H	X	X	01H : Protected, 00H : Unprotected

## NOTE :

1) L=Logic Low=V<sub>IL</sub>, H=Logic High=V<sub>IH</sub>, VID = 8.5V to 9.5V, BA=Block Address, X=Don't care.  
Outermost block : BA255 or BA000

# 10.0 DEVICE OPERATION

## 10.1 Read Mode

The K8P5516UZB is controlled by Chip Enable ( $\overline{CE}$ ), Output Enable ( $\overline{OE}$ ) and Write Enable ( $\overline{WE}$ ). When  $\overline{CE}$  and  $\overline{OE}$  are low and  $\overline{WE}$  is high, the data stored at the specified address location, will be the output of the device. The outputs are in high impedance state whenever  $\overline{CE}$  or  $\overline{OE}$  is high.

The K8P5516UZB is available for 8-Word Page mode. Page mode provides fast access time for high performance system. After address access time ( $t_{AA}$ ), eight data words are loaded into an internal page buffer. A0 (A-1 in byte mode)~A2 bits determine which page word is output during a read operation. A3~A23 bits must be stable throughout the page read access. Figure 13 shows the asynchronous page read more timing.

## 10.2 Standby Mode

The K8P5516UZB features Stand-by Mode to reduce power consumption. This mode puts the device on hold when the device is deselected by making  $\overline{CE}$  high ( $\overline{CE} = V_{IH}$ ). Refer to the DC characteristics for more details on stand-by modes.

## 10.3 Output Disable

The device outputs are disabled when  $\overline{OE}$  is High ( $\overline{OE} = V_{IH}$ ). The output pins are in high impedance state.

## 10.4 Automatic Sleep Mode

The K8P5516UZB features Automatic Sleep Mode to minimize the device power consumption. When addresses remain steady for  $t_{AA}+30ns$ , the device automatically activates the Automatic Sleep Mode. In the sleep mode, output data is latched and always available to the system. When addresses are changed, the device provides new data without wait time.

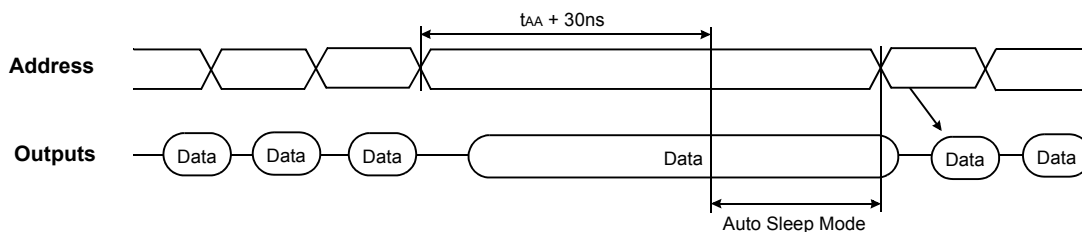

Figure 1: Auto Sleep Mode Operation

## 10.5 Autoselect Mode

The K8P5516UZB offers the Autoselect Mode to identify manufacturer, device type and block protection verification by reading a binary code. The Autoselect Mode allows programming equipment to automatically match the device to be programmed with its corresponding programming algorithm. The manufacturer, device code, block protection verification and indicator bit can be read via the command register. The Command Sequence is shown in Table 6 and Figure 2. In addition, below Table 7 shows indicator bit in detail. The autoselect operation of block protection verification is initiated by first writing two unlock cycle. To terminate the autoselect operation, write Reset command (F0H) into the command register.

**NOTE :** To access the Autoselect codes, the host system must issue the Autoselect command. The Autoselect command sequence can be written to an address within a device that is either in the read or erase-suspend-read mode. The Autoselect command cannot be written while the device is actively programming or erasing. Autoselect does not support page modes. The system must write the reset command to return to the read mode (or erase-suspend read mode if the device was previously in Erase Suspend).

[Table 8] Indicator Bit Codes.

Description	DQ15 to DQ8	DQ7	DQ6 to DQ5	DQ4	DQ3	DQ2	DQ1	DQ0
Indicator Bit	L	1=Factory-Locked 0=Not Locked	L	0 = WP Protects Block 255 1 = WP Protects Block 0	H	L	L	H



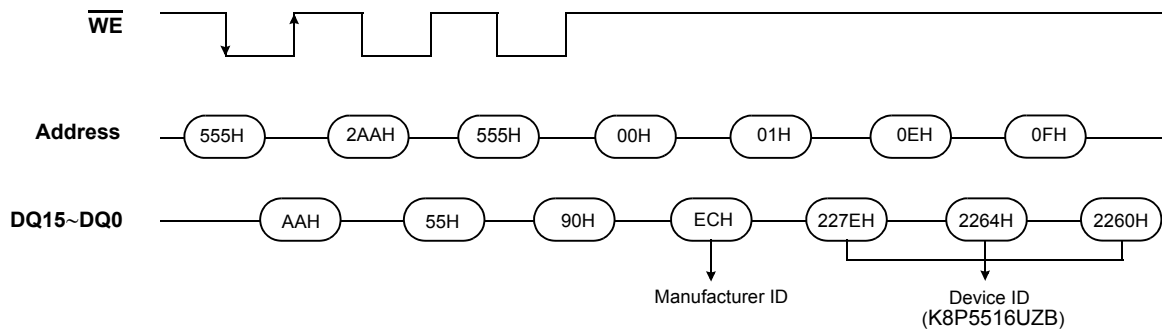

NOTE : Please refer to Table 6 for device code.

Figure 2: Autoselect Operation (by Command Sequence Method)

## 10.6 Write (Program/Erase) Mode

The K8P5516UZB executes its program/erase operations by writing commands into the command register. In order to write the commands to the register,  $\overline{CE}$  and  $\overline{WE}$  must be low and  $\overline{OE}$  must be high. Addresses are latched on the falling edge of  $\overline{CE}$  or  $\overline{WE}$  (whichever occurs last) and the data are latched on the rising edge of  $\overline{CE}$  or  $\overline{WE}$  (whichever occurs first). The device uses standard microprocessor write timing.

### 10.6.1 Program

The K8P5516UZB can be programmed in units of a word. Programming is writing 0's into the memory array by executing the Internal Program Routine. In order to perform the Internal Program Routine, a four-cycle command sequence is necessary. The first two cycles are unlock cycles. The third cycle is assigned for the program setup command. In the last cycle, the address of the memory location and the data to be programmed at that location are written. The device automatically generates adequate program pulses and verifies the programmed cell margin by the Internal Program Routine. During the execution of the Routine, the system is not required to provide further controls or timings. During the Internal Program Routine, commands written to the device will be ignored. Note that a hardware reset during a program operation will cause data corruption at the corresponding location.

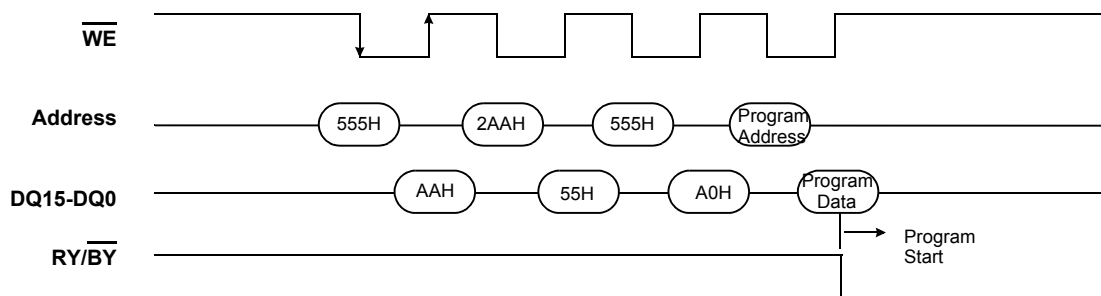

Figure 3: Program Command Sequence

In across block boundaries and any sequence programming is allowed. A bit cannot be programmed from '0' back to '1'. If attempting to do, it may cause that device to set DQ5 = 1, or cause the DQ7 and DQ6 status bits to indicate the operation was successful. However, a succeeding read will show that the data is still '0'. Only erase operations can convert a '0' to a '1'.

## 10.6.2 Writer Buffer Programming

Write Buffer Programming allows the system write to a maximum of 32 words in one programming operation. This results in faster effective programming time than the standard programming algorithms. The Write Buffer Programming command sequence is initiated by first writing two unlock cycles. This is followed by a third write cycle containing the Write Buffer Load command written at the block address in which programming will occur. The fourth cycle writes the block address and the number of word locations, minus one, to be programmed. For example, if the system will program 19 unique address locations, then 12h should be written to the device. This tells the device how many write buffer addresses will be loaded with data. The number of locations to program cannot exceed the size of the write buffer or the operation will abort. The fifth cycle writes the first address location and data to be programmed. **The write-buffer-page is selected by address bits A23(max.) ~ A5 entered at fifth cycle. All subsequent address/ data pairs must fall within the selected write-buffer-page, so that all subsequent addresses must have the same address bit A23(max.) ~ A5 as those entered at fifth cycle. Write buffer locations may be loaded in any order.**

Once the specified number of write buffer locations have been loaded, the system must then write the "Program Buffer to Flash" command at the block address. Any other command address/data combination aborts the Write Buffer Programming operation. The device then begins programming. Data polling should be used while monitoring the last address location loaded into the write buffer. DQ7, DQ6, DQ5, and DQ1 can be monitored to determine the device status during Write Buffer Programming. The write-buffer programming operation can be suspended using the standard program suspend/resume commands. Upon successful completion of the Write Buffer Programming operation, the device is ready to execute the next command.

**Note also that an address location cannot be loaded more than once into the write-buffer-page.**

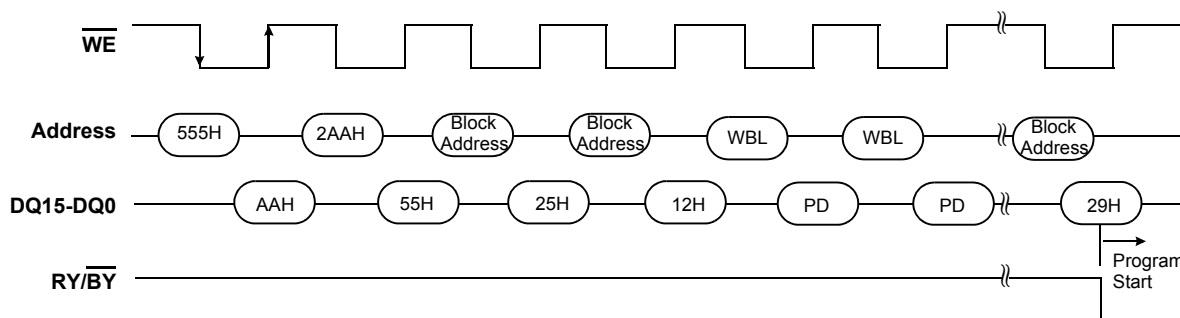

Figure 4: Write Buffer Program Command Sequence

The Write Buffer Programming Sequence can be aborted in the following ways:

- Loading a value that is greater than the buffer size(32-word) during then number of word locations to Program step.  
(In case, WC > 1FH @Table6)
- The number of Program address/data pairs entered is different to the number of word locations initially defined with WC (@Table 5)
- Writing a Program address to have a different write-buffer-page with selected write-buffer-page  
( Address bits A23(max) ~ A5 are different)
- Writing non-exact "Program Buffer to Flash" command

The abort condition is indicated by DQ1 = 1, DQ7 =  $\overline{\text{DATA}}$  (for the last address location loaded), DQ6 = toggle, and DQ5=0. A "Write-to-Buffer-Abort Reset" command sequence must be written to reset the device for the next operation. Note that the third cycle of Write-to-Buffer-Abort Reset command sequence is required when using Write-Buffer-Programming features in Unlock Bypass mode.

And from the third cycle to the last cycle of Write to Buffer command is also required when using Write-Buffer-Programming features in Unlock Bypass mode.

### 10.6.3 Accelerated Program Operation

Accelerated program operation reduces the program time through the ACC function. This is one of two functions provided by the  $\overline{WP/ACC}$  pin. When the  $\overline{WP/ACC}$  pin is asserted as  $V_{HH}$ , the device automatically enters the Unlock Bypass mode, and reduces the program operation time. Removing  $V_{HH}$  from the  $\overline{WP/ACC}$  pin returns the device to normal operation.

Blocks must be unprotected before raising  $\overline{WP/ACC}$  to  $V_{HH}$ .

**Recommend that the  $\overline{WP/ACC}$  pin must not be asserted at  $V_{HH}$  except on accelerated program operation, or the device may be damaged. In addition, the  $\overline{WP/ACC}$  pin must not be in the state of floating or unconnected, otherwise the device may be led to malfunction.**

#### Single word accelerated program operation

The system would use two-cycle program sequence (One-cycle (XXX - A0H) is for single word program command, and Next one-cycle (PA - PD) is for program address and data ).

#### Accelerated Write Buffer Programming

In accelerated Write Buffer Program mode, the system must enter "Write to Buffer" and "Program Buffer to Flash" command sequence to be same as them of normal Write Buffer Programming and only can reduce the program time. Note that the third cycle of "Write to Buffer Abort Reset" command sequence is required in an Accelerated mode.

When the  $\overline{WP/ACC}$  pin is asserted as  $V_{HH}$ , the device automatically enters the Unlock Bypass mode, and reduces the program operation time. Removing  $V_{HH}$  from the  $\overline{WP/ACC}$  pin returns the device to normal operation.

- Program/Erase cycling must be limited below 100cycles for optimum performance.
- Ambient temperature requirements :  $T_A = 30^{\circ}\text{C} \pm 10^{\circ}\text{C}$
- The device automatically generates adequate program pulses and ignores other command after program command

### 10.6.4 Unlock Bypass

The K8P5516UZB provides the unlock bypass mode to save its operation time. This mode is possible for program, CFI, block erase and chip erase operation. There are two methods to enter the unlock bypass mode. The mode is invoked by the unlock bypass command sequence. Unlike the standard program/erase command sequence that contains four to six bus cycles, the unlock bypass program/erase command sequence comprises only two bus cycles. The unlock bypass mode is engaged by issuing the unlock bypass command sequence which is comprised of three bus cycles. Writing first two unlock cycles is followed by a third cycle containing the unlock bypass command (20H). Once the device is in the unlock bypass mode, the unlock bypass program/erase command sequence is necessary. The unlock bypass program command sequence is comprised of only two bus cycles; writing the unlock bypass program command (A0H) is followed by the program address and data. This command sequence is the only valid one for programming the device in the unlock bypass mode. The unlock bypass CFI command sequence is comprised of only one bus cycle; writing the unlock bypass program command (98H). This command sequence is the only valid one for programming the device in the unlock bypass mode. Also, The unlock bypass erase command sequence is comprised of two bus cycles; writing the unlock bypass block erase command(80H-30H) or writing the unlock bypass chip erase command(80H-10H). This command sequences are the only valid ones for erasing the device in the unlock bypass mode. The unlock bypass reset command sequence is the only valid command sequence to exit the unlock bypass mode. The unlock bypass reset command sequence consists of two bus cycles. The first cycle must contain the data (90H). The second cycle contains only the data (00H). Then, the device returns to the read mode.

### 10.6.5 Chip Erase

To erase a chip is to write 1's into the entire memory array by executing the Internal Erase Routine. The Chip Erase requires six bus cycles to write the command sequence. The erase set-up command is written after first two "unlock" cycles. Then, there are two more write cycles prior to writing the chip erase command. The Internal Erase Routine automatically pre-programs and verifies the entire memory for an all zero data pattern prior to erasing. The automatic erase begins on the rising edge of the last WE or CE pulse in the command sequence and terminates when DQ7 is "1". After that the device returns to the read mode.

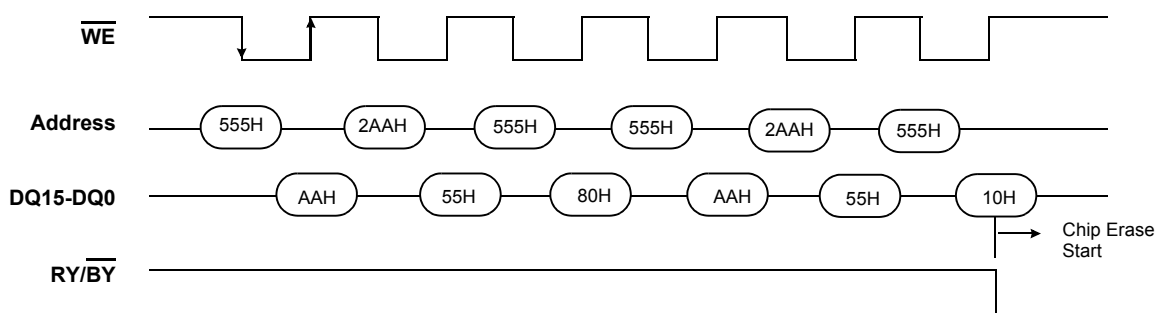

Figure 5: Chip Erase Command Sequence

### 10.6.6 Block Erase

To erase a block is to write 1's into the desired memory block by executing the Internal Erase Routine. The Block Erase requires six bus cycles to write the command sequence shown in Table 5. After the first two "unlock" cycles, the erase setup command (80H) is written at the third cycle. Then there are two more "unlock" cycles followed by the Block Erase command. The Internal Erase Routine automatically pre-programs and verifies the entire memory prior to erasing it. The block address is latched on the falling edge of  $\overline{WE}$  or  $\overline{CE}$ , while the Block Erase command is latched on the rising edge of  $\overline{WE}$  or  $\overline{CE}$ . Multiple blocks can be erased sequentially by writing the six bus-cycle. Upon completion of the last cycle for the Block Erase, additional block address and the Block Erase command (30H) can be written to perform the Multi-Block Erase. An 50us (typical) "time window" is required between the Block Erase command writes. The Block Erase command must be written within the 50us "time window", otherwise the Block Erase command will be ignored. The 50us "time window" is reset when the falling edge of the  $\overline{WE}$  occurs within the 50us of "time window" to latch the Block Erase command. During the 50us of "time window", any command other than the Block Erase or the Erase Suspend command written to the device will reset the device to read mode. After the 50us of "time window", the Block Erase command will initiate the Internal Erase Routine to erase the selected blocks. Any Block Erase address and command following the exceeded "time window" may or may not be accepted. No other commands will be recognized except the Erase Suspend command.

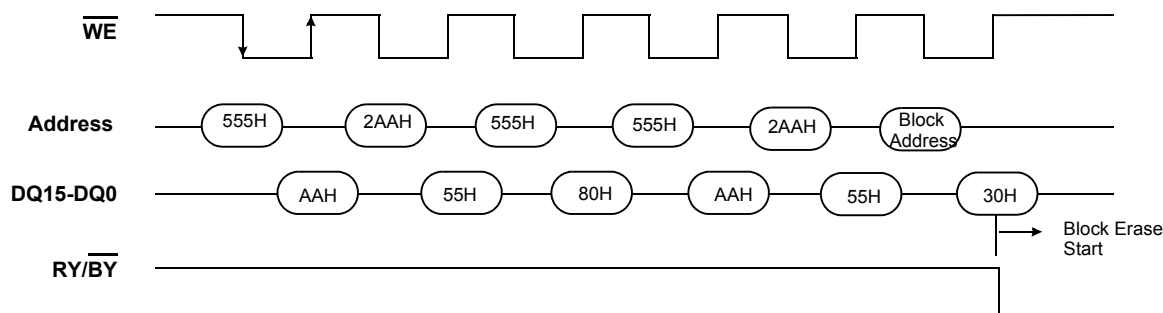

Figure 6: Block Erase Command Sequence

### 10.7 Erase Suspend / Resume

The Erase Suspend command interrupts the Block Erase to read or program data in a block that is not being erased. The Erase Suspend command is only valid during the Block Erase operation including the time window of 50us. The Erase Suspend command is not valid while the Chip Erase or the Internal Program Routine sequence is running.

When the Erase Suspend command is written during a Block Erase operation, the device requires a maximum of 20us to suspend the erase operation. But, when the Erase Suspend command is written during the block erase time window (50us), the device immediately terminates the block erase time window and suspends the erase operation.

After the erase operation has been suspended, the device is available for reading or programming data in a block that is not being erased. The system may also write the autoselect command sequence when the device is in the Erase Suspend mode.

When the Erase Resume command is executed, the Block Erase operation will resume. When the Erase Suspend or Erase Resume command is executed, the addresses are in don't care state. **While erase can be suspended and resumed multiple times, a minimum 30us is required from resume to the next suspend.**

**In the erase suspend mode, protect/unprotect command is prohibited.**

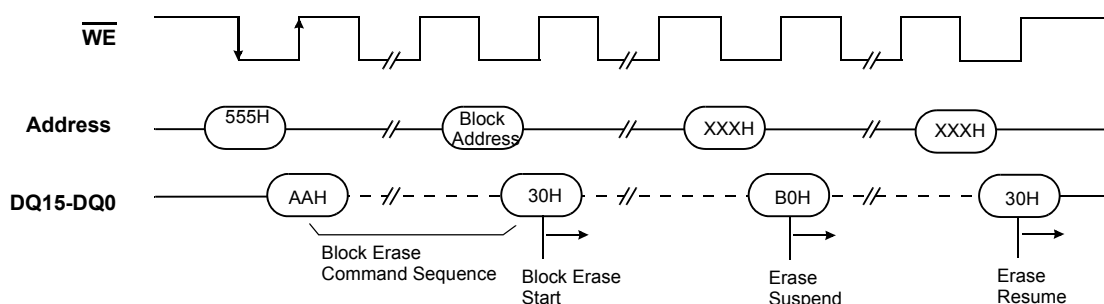

Figure 7: Erase Suspend/Resume Command Sequence

### 10.8 Program Suspend / Resume

The Program Suspend command interrupts the Program operation. Also the Program Suspend command interrupts the Program operation during Erase Suspend Mode. The Read operation is available only during Program Suspend. When the Program Suspend command is written during a Program operation, the device requires a maximum of 10us to suspend the Program operation. The system may also write the autoselect command sequence when the device is in the Program Suspend mode. When the Program Resume command is executed, the Program operation will resume. When the Program Suspend or Program Resume command is executed, the addresses are in don't care state. **While program can be suspended and resumed multiple times, a minimum 30us is required from resume to the next suspend.**

**In the program suspend mode, protect/unprotect command is prohibited.**

## 10.9 Write Protect ( $\overline{WP}$ )

The  $\overline{WP}/ACC$  pin has two useful functions. The one is that certain block is protected by the hardware method not to use  $V_{ID}$ . The other is that program operation is accelerated to reduce the program time (Refer to Accelerated program Operation Paragraph).

When the  $\overline{WP}/ACC$  pin is asserted at  $V_{IL}$ , the device can not perform program and erase operation in the outermost 64 Kword block (BA255 or BA0) on end of the flash array independently of whether that block was protected or unprotected. The write protected blocks can only be read. This is useful method to preserve an important program data.

When the  $\overline{WP}/ACC$  pin is asserted at  $V_{IH}$ , the device reverts the outermost 64Kword block on an end to default protection state. Note that the  $\overline{WP}/ACC$  pin must not be at  $V_{HH}$ , for operations other than accelerated programming, or device damage may result.

## 10.10 Software Reset

The reset command provides that the device is reseted to read mode or erase-suspend-read mode. The addresses are in don't Care state. The reset command is valid between the sequence cycles in an erase command sequence before erasing begins, or in a program command sequence before programming begins. This resets the device in which was operating to read mode. If the device is erasing or programming, the reset command is invalid until the operation is completed. Also, the reset command is valid between the sequence cycles in an autoselect command sequence. In the autoselect mode, the reset command returns the device to read mode. If a device entered the autoselect mode in the Erase Suspend mode, the reset command returns the device to erase-suspend-read mode. If  $DQ5$  is high on erase or program operation, the reset command return the device to read mode or erase-suspend-read mode if the device was in the Erase Suspend state.

## 10.11 Hardware Reset

The K8P5516UZH offers a reset feature by driving the  $\overline{RESET}$  pin to  $V_{IL}$ . When the  $\overline{RESET}$  pin is held low ( $V_{IL}$ ) for at least a period of  $t_{RP}$ , the device immediately terminates any operation in progress, tristates all outputs, and ignores all read/write commands for duration of the  $\overline{RESET}$  pulse. The device also resets the internal state machine to asynchronous read mode. If a hardware reset occurs during a program operation, the data at that particular location will be lost. Once the  $\overline{RESET}$  pin is taken high, the device requires 200ns of wake-up time until outputs are valid for read access. Also, note that all the data output pins are tri-stated for the duration of the  $\overline{RESET}$  pulse. The  $\overline{RESET}$  pin may be tied to the system reset pin. If a system reset occurs during the Internal Program and Erase Routine, the device will be automatically reset to the read mode; this will enable the systems microprocessor to read the boot-up firmware from the Flash memory.

## 10.12 Power-up Protection

To avoid initiation of a write cycle during Vcc Power-up,  $\overline{\text{RESET}}$  low must be asserted during power-up. After  $\overline{\text{RESET}}$  goes high, the device is reset to the read mode.

## 10.13 Low Vcc Write Inhibit

To avoid initiation of a write cycle during Vcc power-up and power-down, a write cycle is locked out for Vcc less than 2.3V. If  $V_{cc} < V_{LKO}$  (Lock-Out Voltage), the command register and all internal program/erase circuits are disabled. Under this condition the device will reset itself to the read mode. Subsequent writes will be ignored until the Vcc level is greater than  $V_{LKO}$ . It is the user's responsibility to ensure that the control pins are logically correct to prevent unintentional writes when Vcc is above 2.3V.

## 10.14 Write Pulse Glitch Protection

Noise pulses of less than 5ns(typical) on  $\overline{\text{CE}}$ ,  $\overline{\text{OE}}$ , or  $\overline{\text{WE}}$  will not initiate a write cycle.

## 10.15 Logical Inhibit

Writing is inhibited under any one of the following conditions :  $\overline{\text{OE}} = V_{IL}$ ,  $\overline{\text{CE}} = V_{IH}$  or  $\overline{\text{WE}} = V_{IH}$ . To initiate a write,  $\overline{\text{CE}}$  and  $\overline{\text{WE}}$  must be "0", while  $\overline{\text{OE}}$  is "1".

## 11.0 COMMON FLASH MEMORY INTERFACE

Common Flash Memory Interface is contrived to increase the compatibility of host system software. It provides the specific information of the device, such as memory size, word configuration, and electrical features. Once this information has been obtained, the system software will know which command sets to use to enable flash writes, block erases, and control the flash component.

When the system writes the CFI command(98H) to address 55H in word mode, the device enters the CFI mode. And then if the system writes the address shown in Table 11, the system can read the CFI data. Query data are always presented on the lowest-order data outputs(DQ0-7) only. In word(x16) mode, the upper data outputs(DQ8-15) is 00h. To terminate this operation, the system must write the reset command.

## 12.0 OTP Block Region

The OTP Block feature provides a 256-word Flash memory region that enables permanent part identification through an Electronic Serial Number (ESN). The OTP Block is customer lockable and shipped with itself unlocked, allowing customers to utilize the that block in any manner they choose. Indicator bit DQ6 are used to indicate the factory-locked of the part. The DQ7 is "1" for factory locked.

The system accesses the OTP Block through a command sequence (see "Enter OTP Block / Exit OTP Block Command sequence" at Table 5 on page 11). After the system has written the "Enter OTP Block" Command sequence, it may read the OTP Block by using the addresses (000000h~0000FFh) normally and may check the Protection Verify Bit (DQ7) by using the "Autoselect Indicator Bit" Command sequence with OTP Block address. This mode of operation continues until the system issues the "Exit OTP Block" Command sequence, a hardware reset or until power is removed from the device. On power-up, or following a hardware reset, the device reverts to sending commands to main blocks. Note that the Accelerated function and unlock bypass modes are not available when the OTP Block is enabled.

### 12.1 OTP Block Protection

In a Customer lockable device, The OTP Block is one-time programmable and can be locked only once. Locking operation to the OTP Block is started by writing the "Enter OTP Block Lock Register Region" Command sequence, and then the "OTP Block Lock Register Bit Program" Command sequence (Table 5) with data that have zero(setting to 0) in DQ0. Note that the other DQs except DQ0 will be ignored. The Locking operation has to be above 100us. After that timing, "Exit OTP Block Lock Register Region" command sequence or Hardware reset must be issued in order to exit OTP block mode and revert the device to read mode in main array.

- The OTP Block Lock operation must be used with caution since, once locked, there is no procedure available for unlocking and none of the bits in the OTP Block space can be modified in any way.
- Suspend and resume operation are not supported during OTP protect, nor is OTP protect supported during any suspend operation.



# 13.0 ENHANCED BLOCK PROTECTION / UNPROTECTION

The Enhanced Block Protection / Unprotection feature disables or enables programming or erase operations in any or all blocks and can be implemented through software and/or hardware methods, which are independent of each other.

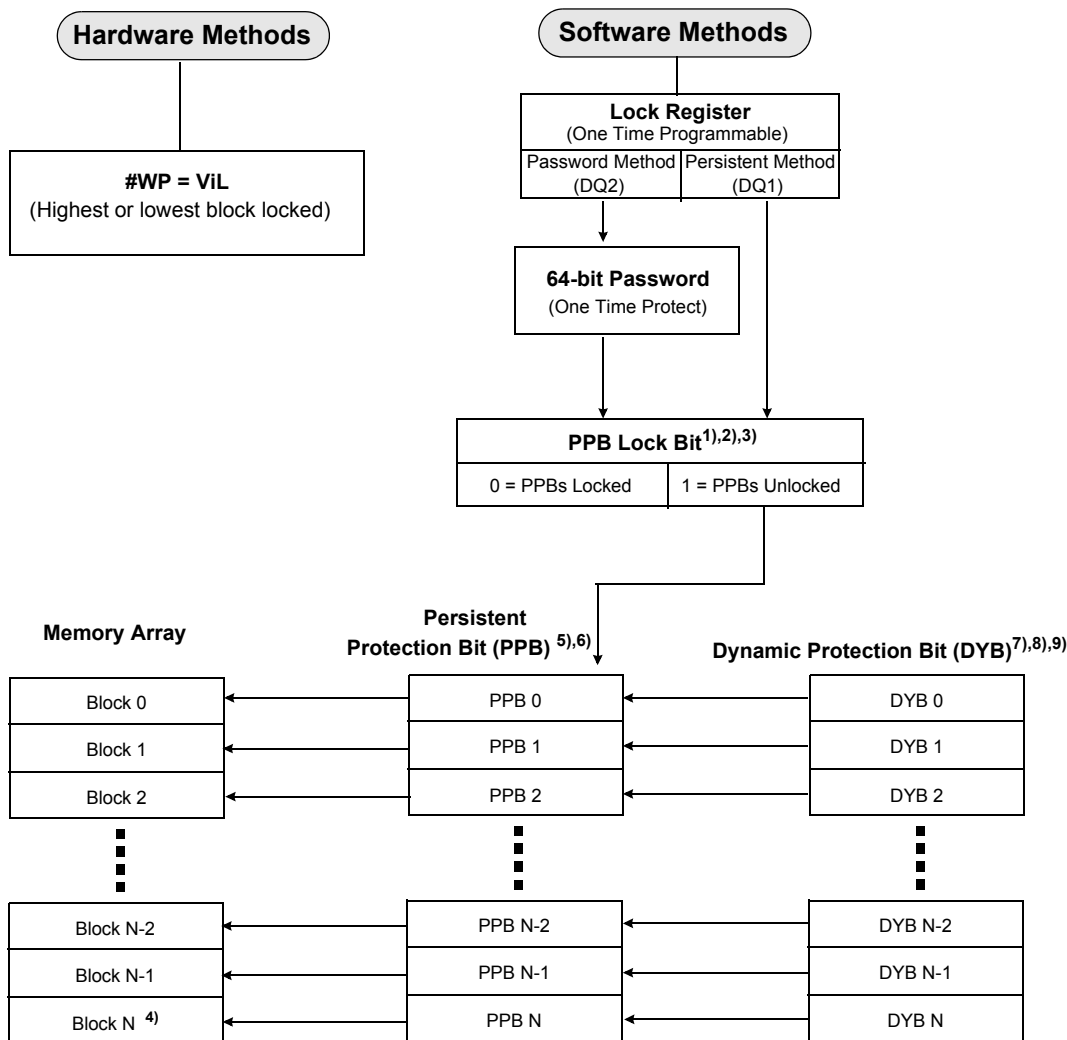

- NOTE :**
- 1) Bit is volatile, and defaults to 1 on reset.
  - 2) Programming to 0 locks all PPBs to their current state.
  - 3) Once programmed to 0, requires hardware reset to unlock.
  - 4) N = Highest Address Block.
  - 5) 0 = Sector Protected, 1 = Sector Unprotected.
  - 6) PPBs programmed individually, but cleared collectively.
  - 7) 0 = Sector Protected, 1 = Sector Unprotected.
  - 8) Protect effective only if PPB Lock Bit is unlocked and corresponding PPB is 1 (unprotected).
  - 9) Volatile Bits: defaults to user choice upon power-up (see ordering options).

Figure 8: Enhanced Block Protection / Unprotection

## 13.1 Block Protection

### 13.1.1 Lock Register

As shipped from the factory, all devices default to the persistent mode when power is applied, and all blocks are unprotected. (DYB is default to clear status : unprotected) For DYB set (protected status) in default, contact your local sales office for details. The device programmer or host system must then choose which block protection method to use. Programming (setting to 0) any one of the following two one-time programmable, non-volatile bits locks the part permanently in that mode:

- Lock Register Persistent Protection Mode Lock Bit (DQ1)
- Lock Register Password Protection Mode Lock Bit (DQ2)

[Table 9] Lock Register.

Device	DQ15 to DQ4	DQ3	DQ2	DQ1	DQ0
K8P5516UZB	Don't Care	PPB One-Time Programmable Bit 0 = All PPB erase command disabled 1 = All PPB Erase command enabled	Password Protection Mode Lock Bit	Persistent Protection Mode Lock Bit	OTP Block Protection Bit

**NOTE :**

- 1) If the password mode is chosen, the password must be programmed before setting the corresponding lock register bit.
- 2) After the Lock Register Bits Command Set Entry command sequence is written, reads and writes for Block 0 are disabled, while reads from other blocks are allowed until exiting this mode.
- 3) If both lock bits are selected to be programmed (to zeros) at the same time, the operation aborts.
- 4) Once the Password Mode Lock Bit is programmed, the Persistent Mode Lock Bit is permanently disabled, and no changes to the protection scheme are allowed. Similarly, if the Persistent Mode Lock Bit is programmed, the Password Mode is permanently disabled.

After selecting a block protection method, each block can operate in any of the following three states:

1. Constantly locked. The selected blocks are protected and cannot be reprogrammed unless PPB lock bit is cleared via a password, hardware reset, or power cycle.
2. Dynamically locked. The selected blocks are protected and can be altered via software commands.
3. Unlocked. The blocks are unprotected and can be erased and/or programmed.

## 13.2 Persistent Protection Bits

The Persistent Protection Bits are unique and nonvolatile for each block and have the same endurance as the Flash memory. Preprogramming and verification prior to erasure are handled by the device, and therefore do not require system monitoring.

**NOTE :**

- 1) Each PPB is individually programmed and all are erased in parallel.
- 2) Entry command disables reads and writes for the block selected.
- 3) Reads within that block 0 return the PPB status for that block.
- 4) Read and Write from other blocks than block 0 are allowed.
- 5) All Reads must be performed using the Asynchronous mode.
- 6) The specific block addresses (A23~A16) are written at the same time as the program command.
- 7) If the PPB Lock Bit is set, the PPB Program or erase command does not execute and timesout without programming or erasing the PPB.
- 8) There are no means for individually erasing a specific PPB and no specific block address is required for this operation.
- 9) Exit command must be issued after the execution which resets the device to read mode and re-enables reads and writes for block 0.
- 10) The programming state of the PPB for a given block can be verified by writing a PPB Status Read Command to the device as described by the flow chart Below.

## 13.3 Dynamic Protection Bits

Dynamic Protection Bits are volatile and unique for each block and can be individually modified. DYBs only control the protection scheme for unprotected blocks that have their PPBs cleared (erased to 1). By issuing the DYB Set or Clear command sequences, the DYBs are set (programmed to 0) or cleared (erased to 1), thus placing each block in the protected or unprotected state respectively. This feature allows software to easily protect blocks against inadvertent changes yet does not prevent the easy removal of protection when changes are needed.

### NOTE :

- 1) The DYBs can be set (programmed to 0) or cleared (erased to 1) as often as needed. When the parts are first shipped, the PPBs are cleared (erased to 1) and upon power up or reset, the DYBs is cleared. For DYB set (protected status) in default, contact your local sales office for details.
- 2) If the option to clear the DYBs after power up is chosen, (erased to 1), then the blocks maybe modified depending upon the PPB state of that block.
- 3) The blocks would be in the protected state If the option to set the DYBs after power up is chosen (programmed to 0).
- 4) It is possible to have blocks that are persistently locked with blocks that are left in the dynamic state.
- 5) The DYB Set or Clear commands for the dynamic blocks signify protected or unprotected state of the blocks respectively. However, if there is a need to change the status of the persistently locked blocks, a few more steps are required. First, the PPB Lock Bit must be cleared by either putting the device through a power-cycle, or hardware reset. The PPBs can then be changed to reflect the desired settings. Setting the PPB Lock Bit once again locks the PPBs, and the device operates normally again.
- 6) To achieve the best protection, it is recommended to execute the PPB Lock Bit Set command early in the boot code and protect the boot code by holding WP# = VIL. Note that the PPB and DYB bits have the same function when WP/ACC = VHH as they do when WP/ACC = VIH.

## 13.4 Persistent Protection Bit Lock Bit

The Persistent Protection Bit Lock Bit is a global volatile bit for all blocks. When set (programmed to 0), this bit locks all PPB and when cleared (programmed to 1), unlocks each block. There is only one PPB Lock Bit per device.

### NOTE :

- 1) No software command sequence unlocks this bit unless the device is in the password protection mode; only a hardware reset or a power-up clears this bit.
- 2) The PPB Lock Bit must be set (programmed to 0) only after all PPBs are configured to the desired settings.

## 13.5 Password Protection Method

The Password Protection Method allows an even higher level of security than the Persistent block Protection Mode by requiring a 64-bit password for unlocking the device PPB Lock Bit. In addition to this password requirement, after power up and reset, the PPB Lock Bit is set 0 to maintain the password mode of operation. Successful execution of the Password Unlock command by entering the entire password clears the PPB Lock Bit, allowing for block PPBs modifications.

### NOTE :

- 1) There is no special addressing order required for programming the password. Once the Password is written and verified, the Password Mode Locking Bit must be set to prevent access.
- 2) The Password Program Command is only capable of programming 0s. Programming a 1 after a cell is programmed as a 0 results in a time-out with the cell as a 0.
- 3) The password is all 1s when shipped from the factory.
- 4) All 64-bit password combinations are valid as a password.
- 5) There is no means to verify what the password is after it is set.
- 6) The Password Mode Lock Bit, once set, prevents reading the 64-bit password on the data bus and further password programming.
- 7) The Password Mode Lock Bit is not erasable.
- 8) The lower two address bits (A1~ A0(A-1 in byte mode)) are valid during the Password Read, Password Program, and Password Unlock.
- 9) The exact password must be entered in order for the unlocking function to occur.
- 10) The Password Unlock command cannot be issued any faster than 1us at a time to prevent a hacker from running through all the 64-bit combinations in an attempt to correctly match a password.
- 11) Approximately 1us is required for unlocking the device after the valid 64-bit password is given to the device.
- 12) Password verification is only allowed during the password programming operation.
- 13) All further commands to the password region are disabled and all operations are ignored.
- 14) If the password is lost after setting the Password Mode Lock Bit, there is no way to clear the PPB Lock Bit.
- 15) Entry command sequence must be issued prior to any of any operation and it disables reads and writes for block 0. Reads and writes for other blocks excluding block 0 are allowed.
- 16) If the user attempts to program or erase a protected block, the device ignores the command and returns to read mode.
- 17) A program or erase command to a protected block enables status polling and returns to read mode without having modified the contents of the protected block.
- 18) The programming of the DYB, PPB, and PPB Lock for a given block can be verified by writing individual status read commands DYB Status, PPB Status, and PPB Lock Status to the device.

### 13.6 Master locking bit set

This Master locking bit can ensure that protected blocks be permanently unalterable. Master locking bit is non-volatile bit. Master locking bit controls protection status of entire blocks that is protected by PPB. To make permanent protection block, PPB should be protected first. The usage of the master locking bit command sequence is absolutely required to ensure full protection of data from future alterations. If master locking bit is set ("0"), entire blocks that were protected by PPB are permanently protected. They are not changed and altered by any future lock/unlock commands. Anyone who uses this function needs much attention. Because there is no way to return to unlock status. Default status of master locking bit is unlock status("1"). If Master locking bit sets on unprotected block, the block still are remaining in status of unprotected block. Additionally the unprotected block can be protected by PPB program command. And then the block is protected permanently.

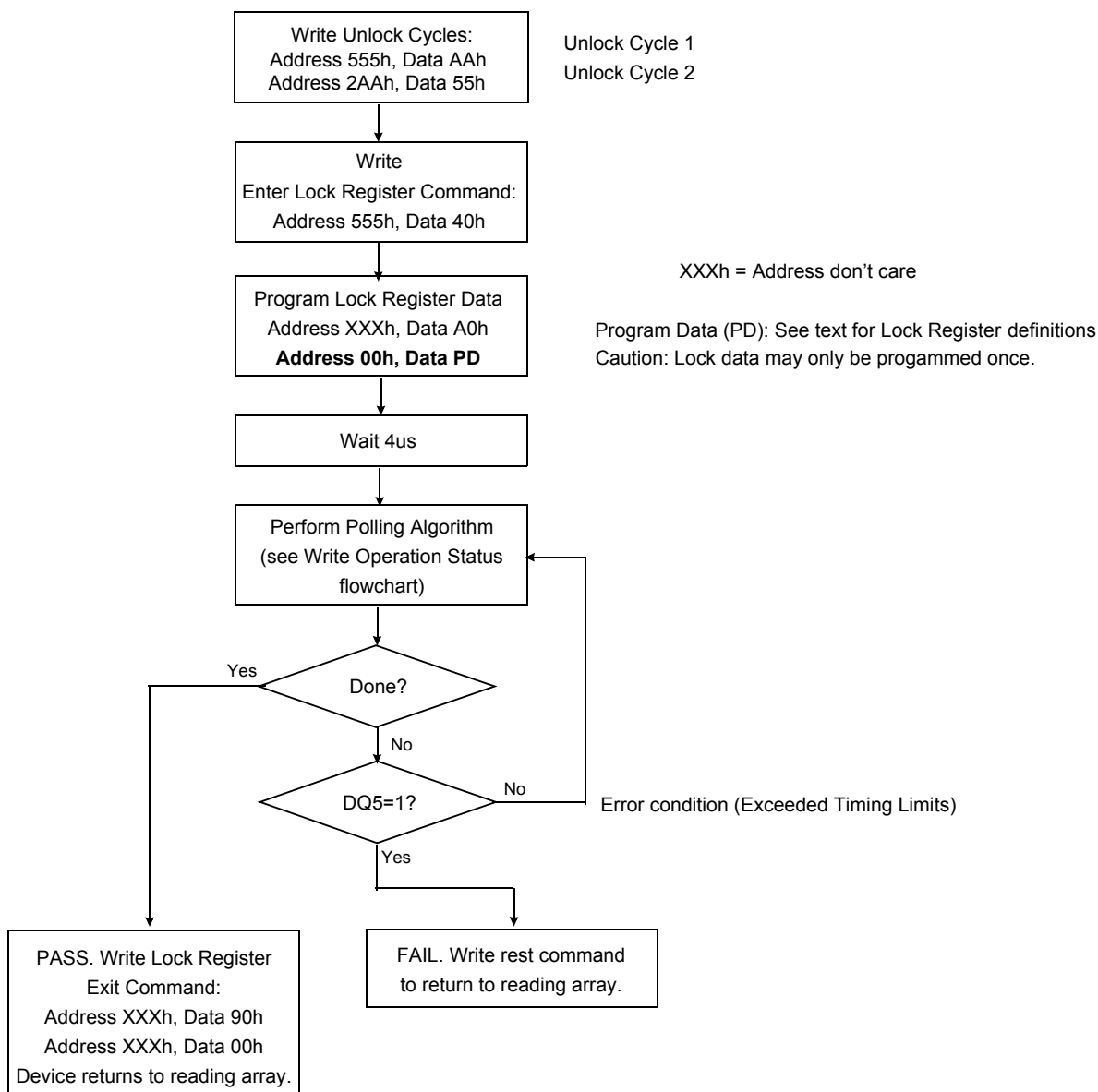

Figure 9: Lock Register Program Algorithm

[Table 10] Block Protection examples

Unique Device PPB Lock Bit 0 = locked, 1 = unlocked		Block PPB 0 = protected	Block DYB 0 = protected	Block Protection Status
Any Block	0	0	X	Protected through PPB
Any Block	0	0	X	Protected through PPB
Any Block	0	1	1	Unprotected
Any Block	0	1	0	Protected through DYB
Any Block	1	0	X	Protected through PPB
Any Block	1	0	X	Protected through PPB
Any Block	1	1	0	Protected through DYB
Any Block	1	1	1	Unprotected

[Table 11] Block protection commands (x16)

Command Definitions		Cycle	1st Cycle	2nd Cycle	3rd Cycle	4th Cycle	5th Cycle	6th Cycle	7th Cycle
Enter Lock Register Region <sup>25)</sup>	Addr	3	555H	2AAH	555H				
	Data		AAH	55H	40H				
Lock Register Bit Read	Addr	1	00H						
	Data		RD						
Lock Register Bit Program <sup>26)</sup>	Addr	2	XXXH	XXXH					
	Data		A0H	DATA					
Exit Lock Register Region <sup>27)</sup>	Addr	2	XXXH	XXXH					
	Data		90H	00H					
Password Protection Command Set Entry <sup>25)</sup>	Addr	3	555H	2AAH	555H				
	Data		AAH	55H	60H				
Password Program	Addr	2	XXXH	PWA0/ PWA1/ PWA2/ PWD0/ PWD1 /PWD2/					
	Data		A0H						
Password Read	Addr	4	00H	01H	02H	03H			
	Data		PWD0	PWD1	PWD2	PWD3			
Password Unlock	Addr	7	00H	00H	00H	01H	02H	03H	00H
	Data		25H	03H	PWD0	PWD1	PWD2	PWD3	29H
Password Protection Command Set Exit <sup>27)</sup>	Addr	2	XXXH	XXXH					
	Data		90H	00H					
PPB Block Protection Command Set Entry <sup>25)</sup>	Addr	3	555H	2AAH	555H				
	Data		AAH	55H	C0H				
PPB Program	Addr	2	XXXH	BA					
	Data		A0H	00H					
All PPB Erase <sup>22)</sup>	Addr	2	XXXH	00H					
	Data		80H	30H					
PPB Status Read	Addr	1	BA						
	Data		RD(0)						
PPB Block Protection Command Set Exit <sup>27)</sup>	Addr	2	XXXH	XXXH					
	Data		90H	00H					
PPB Lock Bit Command Set Entry <sup>25)</sup>	Addr	3	555H	2AAH	555H				
	Data		AAH	55H	50H				
PPB Lock Bit Set	Addr	2	XXXH	XXXH					
	Data		A0H	00H					
PPB Lock Bit Status Read	Addr	1	XXXH						
	Data		RD(0)						
PPB Lock Bit Command Set Exit <sup>27)</sup>	Addr	2	XXXH	XXXH					
	Data		90H	00H					
DYB Command Set Entry <sup>25)</sup>	Addr	3	555H	2AAH	555H				
	Data		AAH	55H	E0H				
DYB Set	Addr	2	XXXH	BA					
	Data		A0H	00H					
DYB Clear	Addr	2	XXXH	BA					
	Data		A0H	01H					
DYB Status Read	Addr	1	BA						
	Data		RD(0)						
DYB Command Set Exit <sup>28)</sup>	Addr	2	XXXH	XXXH					
	Data		90H	00H					
Master Locking Bit Set	Addr	3	555H	2AAH	555H				
	Data		AAH	55H	F1H				

**NOTE :**

- RA : Read Address, PA : Program Address, RD : Read Data, PD : Program Data, WBL : Write Buffer Location
- BA : Block Address (A16 - A23), ABP : Address of the block to be protected or unprotected, X = Don't care .
- DQ8 - DQ15 are don't care in command sequence, except for RD and PD
- A14 - A23 are also don't care, except for the case of special notice.
- WC = Word Count. Number of write buffer locations to load minus 1.
- PWA3 ~ PWA0 = Password Address. PWD3 ~ PWD0 = Password Data.  
PD3 ~ PD0 present four 16 bit combinations that represent the 64-bit Password
- RD(0) = DQ0 protection indicator bit. If protected, DQ0 = 0, if unprotected, DQ0 = 1.

- 1) See bus operations description
- 2) All values are in hexadecimal.
- 3) Except for the following, all bus cycles are write cycle: read cycle, fourth through sixth cycles of the Autoselect commands, and password verify commands, and any cycle reading at RD(0) and RD(1).
- 4) Data bits DQ15 ~ DQ8 are don't care in command sequences, except for RD, PD, WD, PWD, and PWD3 ~ PWD0.
- 5) Unless otherwise noted, these address bits are don't cares: (A23 ~ A14)
- 6) Writing incorrect address and data values or writing them in the improper sequence may place the device in an unknown state. The system must write the reset command to return the device to reading array data.
- 7) No unlock or command cycles required when reading array data.
- 8) The Reset command is required to return to reading array data (or to the erase-suspend-read mode if previously in Erase Suspend) when the device is in the autoselect mode, or if DQ5 goes high (while the device is providing status information) or performing block lock/unlock.
- 9) The fourth cycle of the autoselect command sequence is a read cycle. See Autoselect.
- 10) The data is 0000h for an unlocked block and 0001h for a locked block.
- 11) Device ID data : X0EH = "2264H", X0FH = "2260H" for 256Mb Uniform Block Device
- 12) See Autoselect.
- 13) The Unlock Bypass command sequence is required prior to this command sequence.
- 14) The Unlock Bypass Reset command is required to return to reading array data when the device is in the unlock bypass mode. The system may read and program in non-erasing blocks, or enter the autoselect mode, when in the Erase Suspend mode. The Erase Suspend command is valid only during a block erase operation.
- 15) The Erase Resume command is valid only during the Erase Suspend mode.
- 16) Command is valid when device is ready to read array data or when device is in autoselect mode. The total number of cycles in the command sequence is determined by the number of words written to the write buffer. The maximum number of cycles in the command sequence is 37.
- 17) The entire four bus-cycle sequence must be entered for which portion of the password.
- 18) The Unlock Bypass Reset command is required to return to reading array data when the device is in the unlock bypass mode. The system may read and program in non-erasing blocks, or enter the autoselect mode, when in the Erase Suspend mode. The Erase Suspend command is valid only during a block erase operation.
- 19) The Erase Resume command is valid only during the Erase Suspend mode.
- 20) Command is valid when device is ready to read array data or when device is in autoselect mode. The total number of cycles in the command sequence is determined by the number of words written to the write buffer. The maximum number of cycles in the command sequence is 37.
- 21) The entire four bus-cycle sequence must be entered for which portion of the password.
- 22) The ALL PPB ERASE command pre-programs all PPBs before erasure to prevent over-erasure of PPBs.
- 23) WP/ACC must be at VHH during the entire operation of this command.
- 24) Command sequence resets device for next command after write-to-buffer operation.
- 25) Entry commands are needed to enter a specific mode to enable instructions only available within that mode.
- 26) If both the Persistent Protection Mode Locking Bit and the password Protection Mode Locking Bit are set at the same time, the command operation aborts and returns the device to the default Persistent block Protection Mode.
- 27) The Exit command must be issued to reset the Block 0 of device into read mode. Otherwise the device hangs.
- 28) The Exit command must be issued to reset device into read mode. Otherwise the device hangs.

[Table 12] Block protection commands (x8)

Command Definitions		Cycle	1st Cycle	2nd Cycle	3rd Cycle	4th Cycle	5th Cycle	6th Cycle	7th Cycle
Enter Lock Register Region <sup>25)</sup>	Addr	3	AAAH	555H	AAAH				
	Data		AAH	55H	40H				
Lock Register Bit Read	Addr	1	00H						
	Data		RD						
Lock Register Bit Program <sup>26)</sup>	Addr	2	XXXH	XXXH					
	Data		A0H	DATA					
Exit Lock Register Region <sup>27)</sup>	Addr	2	XXXH	XXXH					
	Data		90H	00H					
Password Protection Command Set Entry <sup>25)</sup>	Addr	3	AAAH	555H	AAAH				
	Data		AAH	55H	60H				
Password Program	Addr	2	XXXH	PWAx					
	Data		A0H	PWDx					
Password Read	Addr	8	00H	01H	02H	03H	04H	05H	06H
	Data		PWD0	PWD1	PWD2	PWD3	PWD4	PWD5	PWD6
	Addr		07H						
	Data		PWD7						
Password Unlock	Addr	11	00H	00H	00H	01H	02H	03H	04H
	Data		25H	03H	PWD0	PWD1	PWD2	PWD3	PWD4
	Addr		05H	06H	07H	00H			
	Data		PWD5	PWD6	PWD7	29			
Password Protection Command Set Exit <sup>27)</sup>	Addr	2	XXXH	XXXH					
	Data		90H	00H					
PPB Block Protection Command Set Entry <sup>25)</sup>	Addr	3	AAAH	555H	AAAH				
	Data		AAH	55H	C0H				
PPB Program	Addr	2	XXXH	BA					
	Data		A0H	00H					
All PPB Erase <sup>22)</sup>	Addr	2	XXXH	00H					
	Data		80H	30H					
PPB Status Read	Addr	1	BA						
	Data		RD(0)						
PPB Block Protection Command Set Exit <sup>27)</sup>	Addr	2	XXXH	XXXH					
	Data		90H	00H					
PPB Lock Bit Command Set Entry <sup>25)</sup>	Addr	3	AAAH	555H	AAAH				
	Data		AAH	55H	50H				
PPB Lock Bit Set	Addr	2	XXXH	XXXH					
	Data		A0H	00H					
PPB Lock Bit Status Read	Addr	1	XXXH						
	Data		RD(0)						
PPB Lock Bit Command Set Exit <sup>27)</sup>	Addr	2	XXXH	XXXH					
	Data		90H	00H					
DYB Command Set Entry <sup>25)</sup>	Addr	3	AAAH	555H	AAAH				
	Data		AAH	55H	E0H				
DYB Set	Addr	2	XXXH	BA					
	Data		A0H	00H					
DYB Clear	Addr	2	XXXH	BA					
	Data		A0H	01H					
DYB Status Read	Addr	1	BA						
	Data		RD(0)						
DYB Command Set Exit <sup>28)</sup>	Addr	2	XXXH	XXXH					
	Data		90H	00H					
Master Locking Bit Set	Addr	3	AAAH	555H	AAAH				
	Data		AAH	55H	F1H				



**NOTE :**

- RA : Read Address, PA : Program Address, RD : Read Data, PD : Program Data, WBL : Write Buffer Location
  - BA : Block Address (A16 - A23), ABP : Address of the block to be protected or unprotected, X = Don't care .
  - DQ8 - DQ15 are don't care in command sequence, except for RD and PD
  - A14 - A23 are also don't care, except for the case of special notice.
  - WC = Word Count. Number of write buffer locations to load minus 1.
  - PWA3 ~ PWA0 = Password Address. PWD7 ~ PWD0 = Password Word0, Word1, Word2, Word3  
PD3 ~ PD0 present four 16 bit combinations that represent the 64-bit Password
  - RD(0) = DQ0 protection indicator bit. If protected, DQ0 = 0, if unprotected, DQ0 = 1.
- 1) See bus operations description
  - 2) All values are in hexadecimal.
  - 3) Except for the following, all bus cycles are write cycle: read cycle, fourth through sixth cycles of the Autoselect commands, and password verify commands, and any cycle reading at RD(0) and RD(1).
  - 4) Data bits DQ15 ~ DQ8 are don't care in command sequences, except for RD, PD, WD, PWD, and PWD3 ~ PWD0.
  - 5) Unless otherwise noted, these address bits are don't cares: (A23 ~ A14)
  - 6) Writing incorrect address and data values or writing them in the improper sequence may place the device in an unknown state. The system must write the reset command to return the device to reading array data.
  - 7) No unlock or command cycles required when reading array data.
  - 8) The Reset command is required to return to reading array data (or to the erase-suspend-read mode if previously in Erase Suspend) when the device is in the autoselect mode, or if DQ5 goes high (while the device is providing status information) or performing block lock/unlock.
  - 9) The fourth cycle of the autoselect command sequence is a read cycle. See Autoselect.
  - 10) The data is 0000h for an unlocked block and 0001h for a locked block.
  - 11) Device ID data : X0EH = "2264H", X0FH = "2260H" for 256Mb Uniform Block Device
  - 12) See Autoselect.
  - 13) The Unlock Bypass command sequence is required prior to this command sequence.
  - 14) The Unlock Bypass Reset command is required to return to reading array data when the device is in the unlock bypass mode. The system may read and program in non-erasing blocks, or enter the autoselect mode, when in the Erase Suspend mode. The Erase Suspend command is valid only during a block erase operation.
  - 15) The Erase Resume command is valid only during the Erase Suspend mode.
  - 16) Command is valid when device is ready to read array data or when device is in autoselect mode. The total number of cycles in the command sequence is determined by the number of words written to the write buffer. The maximum number of cycles in the command sequence is 37.
  - 17) The entire four bus-cycle sequence must be entered for which portion of the password.
  - 18) The Unlock Bypass Reset command is required to return to reading array data when the device is in the unlock bypass mode. The system may read and program in non-erasing blocks, or enter the autoselect mode, when in the Erase Suspend mode. The Erase Suspend command is valid only during a block erase operation.
  - 19) The Erase Resume command is valid only during the Erase Suspend mode.
  - 20) Command is valid when device is ready to read array data or when device is in autoselect mode. The total number of cycles in the command sequence is determined by the number of words written to the write buffer. The maximum number of cycles in the command sequence is 37.
  - 21) The entire four bus-cycle sequence must be entered for which portion of the password.
  - 22) The ALL PPB ERASE command pre-programs all PPBs before erasure to prevent over-erasure of PPBs.
  - 23) WP/ACC must be at VHH during the entire operation of this command.
  - 24) Command sequence resets device for next command after write-to-buffer operation.
  - 25) Entry commands are needed to enter a specific mode to enable instructions only available within that mode.
  - 26) If both the Persistent Protection Mode Locking Bit and the password Protection Mode Locking Bit are set at the same time, the command operation aborts and returns the device to the default Persistent block Protection Mode.
  - 27) The Exit command must be issued to reset the Block 0 of device into read mode. Otherwise the device hangs.
  - 28) The Exit command must be issued to reset device into read mode. Otherwise the device hangs.

[Table 13] Common Flash Memory Interface Code

Description	Addresses (Word Mode)	Addresses (Byte Mode)	Data
Query Unique ASCII string "QRY"	10H	20H	0051H
	11H	22H	0052H
	12H	24H	0059H
Primary OEM Command Set	13H	26H	0002H
	14H	28H	0000H
Address for Primary Extended Table	15H	2AH	0040H
	16H	2CH	0000H
Alternate OEM Command Set (00h = none exists)	17H	2EH	0000H
	18H	30H	0000H
Address for Alternate OEM Extended Table (00h = none exists)	19H	32H	0000H
	1AH	34H	0000H
Vcc Min. (write/erase) D7-D4: volt, D3-D0: 100 millivolt	1BH	36H	0027H
Vcc Max. (write/erase) D7-D4: volt, D3-D0: 100 millivolt	1CH	38H	0036H
Vpp Min. voltage(00H = no Vpp pin present)	1DH	3AH	0000H
Vpp Max. voltage(00H = no Vpp pin present)	1EH	3CH	0000H
Typical timeout per single word write 2 <sup>N</sup> us	1FH	3EH	0006H
Typical timeout for Min. size buffer write 2 <sup>N</sup> us(00H = not supported)	20H	40H	0006H
Typical timeout per individual block erase 2 <sup>N</sup> ms	21H	42H	0009H
Typical timeout for full chip erase 2 <sup>N</sup> ms(00H = not supported)	22H	44H	0013H
Max. timeout for word write 2 <sup>N</sup> times typical	23H	46H	0003H
Max. timeout for buffer write 2 <sup>N</sup> times typical	24H	48H	0005H
Max. timeout per individual block erase 2 <sup>N</sup> times typical	25H	4AH	0003H
Max. timeout for full chip erase 2 <sup>N</sup> times typical(00H = not supported)	26H	4CH	0002H
Device Size = 2 <sup>N</sup> byte	27H	4EH	0019H
Flash Device Interface description	28H	50H	0002H
	29H	52H	0000H
Max. number of byte in multi-byte write = 2 <sup>N</sup>	2AH	54H	0006H
	2BH	56H	0000H
Number of Erase Block Regions within device	2CH	58H	0001H
Erase Block Region 1 Information	2DH	5AH	00FFH
	2EH	5CH	0000H
	2FH	5EH	0000H
	30H	60H	0002H
Erase Block Region 2 Information	31H	62H	0000H
	32H	64H	0000H
	33H	66H	0000H
	34H	68H	0000H
Erase Block Region 3 Information	35H	6AH	0000H
	36H	6CH	0000H
	37H	6EH	0000H
	38H	70H	0000H
Erase Block Region 4 Information	39H	72H	0000H
	3AH	74H	0000H
	3BH	76H	0000H
	3CH	78H	0000H

Description	Addresses (Word Mode)	Addresses (Byte Mode)	Data
Query-unique ASCII string "PRI"	40H 41H 42H	80H 82H 84H	0050H 0052H 0049H
Major version number, ASCII	43H	86H	0031H
Minor version number, ASCII	44H	88H	0033H
Address Sensitive Unlock(Bits 1-0) 0 = Required, 1= Not Required Silcon Revision Number(Bits 7-2)	45H	8AH	0014H
Erase Suspend 0 = Not Supported, 1 = To Read Only, 2 = To Read & Write	46H	8CH	0002H
Block Protect 00 = Not Supported, 01 = Supported	47H	8EH	0001H
Block Temporary Unprotect 00 = Not Supported, 01 = Supported	48H	90H	0000H
Block Protect/Unprotect scheme, 08 = Enhanced Block Protection	49H	92H	0008H
Simultaneous Operation 00 = Not Supported, XX = Number of Blocks except Bank 0	4AH	94H	0000H
Burst Mode Type 00 = Not Supported, 01 = Supported	4BH	96H	0000H
Page Mode Type 00 = Not Supported, 01 = 4 Word Page, 02 = 8 Word Page	4CH	98H	0002H
ACC(Acceleration) Supply Minimum 00 = Not Supported, D7 - D4 : Volt, D3 - D0 : 100mV	4DH	9AH	0085H
ACC(Acceleration) Supply Maximum 00 = Not Supported, D7 - D4 : Volt, D3 - D0 : 100mV	4EH	9CH	0095H
$\overline{WP}$ protect 04 = Uniform Blocks Bottom $\overline{WP}$ protect. 05 = Uniform Blocks Top $\overline{WP}$ protect.	4FH	9EH	00XXH
Program Suspend 00 = Not Supported. 01 = Supported.	50H	A0H	0001H

## 14.0 DEVICE STATUS FLAGS

The K8P5516UZH has means to indicate its status of operation in the device where a program or erase operation is in processes. The status is indicated by raising the device status flag via corresponding DQ pins or the RY/ BY pin. The corresponding DQ pins are DQ7, DQ6, DQ5, DQ3, DQ2 and DQ1. The statuses are as follows :

[Table 14] Hardware Sequence Flags

	Status	DQ7	DQ6	DQ5	DQ3	DQ2	DQ1	
In Progress	Programming	DQ7	Toggle	0	0	1	0	
	Block Erase or Chip Erase	0	Toggle	0	1	Toggle	1	
	Erase Suspend Read	Erase Suspended Block	1	1	0	0	Toggle <sup>1)</sup>	1
	Erase Suspend Read	Non-Erase Suspended Block	Data	Data	Data	Data	Data	Data
	Erase Suspend Program	Non-Erase Suspended Block	DQ7	Toggle	0	0	1	0
	Program Suspend Read	Program Suspended Block	Invalid	Invalid	Invalid	Invalid	Invalid	Invalid
	Program Suspend Read	Non-Program Suspended Block	Data	Data	Data	Data	Data	Data
Write to Buffer <sup>2)</sup>	BUSY State	DQ7	Toggle	0	0	No Toggle	0	
	ABORT State	DQ7	Toggle	0	0	No Toggle	1	

**NOTE :**

- 1) DQ2 will toggle when the device performs successive read operations from the erase/program suspended block.  
 2) Note that DQ7 during Write-to-Buffer-Programming indicates the data-bar for DQ7 for the last loaded write-buffer address location.

### DQ7 : Data Polling

When an attempt to read the device is made while executing the Internal Program, the complement of the data is written to DQ7 as an indication of the Routine in progress. When the Routine is completed an attempt to access to the device will produce the true data written to DQ7. When a user attempts to read the block being erased, DQ7 will be low. If the device is placed in the Erase/Program Suspend Mode, the status can be detected via the DQ7 pin. If the system tries to read an address which belongs to a block that is being erase suspended, DQ7 will be high. And, if the system tries to read an address which belongs to a block that is being program suspended, the output will be the true data of DQ7 itself. If a non-erase-suspended or non-program-suspended block address is read, the device will produce the true data to DQ7. If an attempt is made to program a protected block, DQ7 outputs complements the data for approximately 1 $\mu$ s and the device then returns to the Read Mode without changing data in the block. If an attempt is made to erase a protected block, DQ7 outputs complement data in approximately 100 $\mu$ s and the device then returns to the Read Mode without erasing the data in the block.

### DQ6 : Toggle Bit

Toggle bit is another option to detect whether an Internal Routine is in progress or completed. Once the device is at a busy state, DQ6 will toggle. Toggling DQ6 will stop after the device completes its Internal Routine. If the device is in the Erase/Program Suspend Mode, an attempt to read an address that belongs to a block that is being erased or programmed will produce a high output of DQ6. If an address belongs to a block that is not being erased or programmed, toggling is halted and valid data is produced at DQ6. If an attempt is made to program a protected block, DQ6 toggles for approximately 1 $\mu$ s and the device then returns to the Read Mode without changing the data in the block. If an attempt is made to erase a protected block, DQ6 toggles for approximately 100 $\mu$ s and the device then returns to the Read Mode without erasing the data in the block.

**DQ5 : Exceed Timing Limits**

If the Internal Program/Erase Routine extends beyond the timing limits, DQ5 will go High, indicating program/erase failure.

**DQ3 : Block Erase Timer**

The status of the multi-block erase operation can be detected via the DQ3 pin. DQ3 will go High if 50 $\mu$ s of the block erase time window expires. In this case, the Internal Erase Routine will initiate the erase operation. Therefore, the device will not accept further write commands until the erase operation is completed. DQ3 is Low if the block erase time window is not expired. Within the block erase time window, an additional block erase command (30H) can be accepted. To confirm that the block erase command has been accepted, the software may check the status of DQ3 following each block erase command.

**DQ2 : Toggle Bit 2**

The device generates a toggling pulse in DQ2 only if an Internal Erase Routine or an Erase/Program Suspend is in progress. When the device executes the Internal Erase Routine, DQ2 toggles only if an erasing block is read. Although the Internal Erase Routine is in the Exceeded Time Limits, DQ2 toggles only if an erasing block in the Exceeded Time Limits is read. When the device is in the Erase/Program Suspend mode, DQ2 toggles only if an address in the erasing or programming block is read. If a non-erasing or non-programmed block address is read during the Erase/Program Suspend mode, then DQ2 will produce valid data. DQ2 will go High if the user tries to program a non-erase suspend block while the device is in the Erase Suspend mode.

**DQ1 : Buffer Program Abort Indicator**

DQ1 indicates whether a Write-to-Buffer operation was aborted. Under these conditions DQ1 produces a "1". The system must issue the Write-to-Buffer-Abort-Reset command sequence to return the device to reading array data.

 **$\overline{\text{RY}}/\overline{\text{BY}}$  : Ready/Busy**

The pin is an open drain output, allowing two or more Ready/Busy outputs to be OR-tied. An appropriate pull-up resistor by system is required for proper operation.

The K8P5516UZB has a Ready/Busy output that indicates either the completion of an operation or the status of Internal Algorithms. If the output is Low, the device is busy with either a program or an erase operation. If the output is High, the device is ready to accept any read/write or erase operation. When the RY/ BY pin is low, the device will not accept any additional program or erase commands with the exception of the Erase Suspend command. If the K8P5516UZB is placed in an Erase Suspend mode, the RY/ BY output will be High. For programming, the RY/ BY is valid ( $\overline{\text{RY}}/\overline{\text{BY}} = 0$ ) after the rising edge of the fourth  $\overline{\text{WE}}$  pulse in the four write pulse sequence. For Chip Erase, RY/ BY is also valid after the rising edge of  $\overline{\text{WE}}$  pulse in the six write pulse sequence. For Block Erase, RY/ BY is also valid after the rising edge of the sixth  $\overline{\text{WE}}$  pulse.

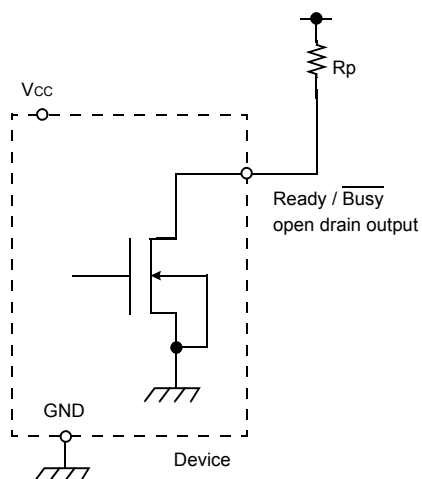

$$R_p = \frac{V_{cc} (\text{Max.}) - V_{OL} (\text{Max.})}{I_{OL} + \sum I_L} = \frac{3.5 \text{ V}}{2.1 \text{ mA} + \sum I_L}$$

where  $\sum I_L$  is the sum of the input currents of all devices tied to the Ready / Busy pin.

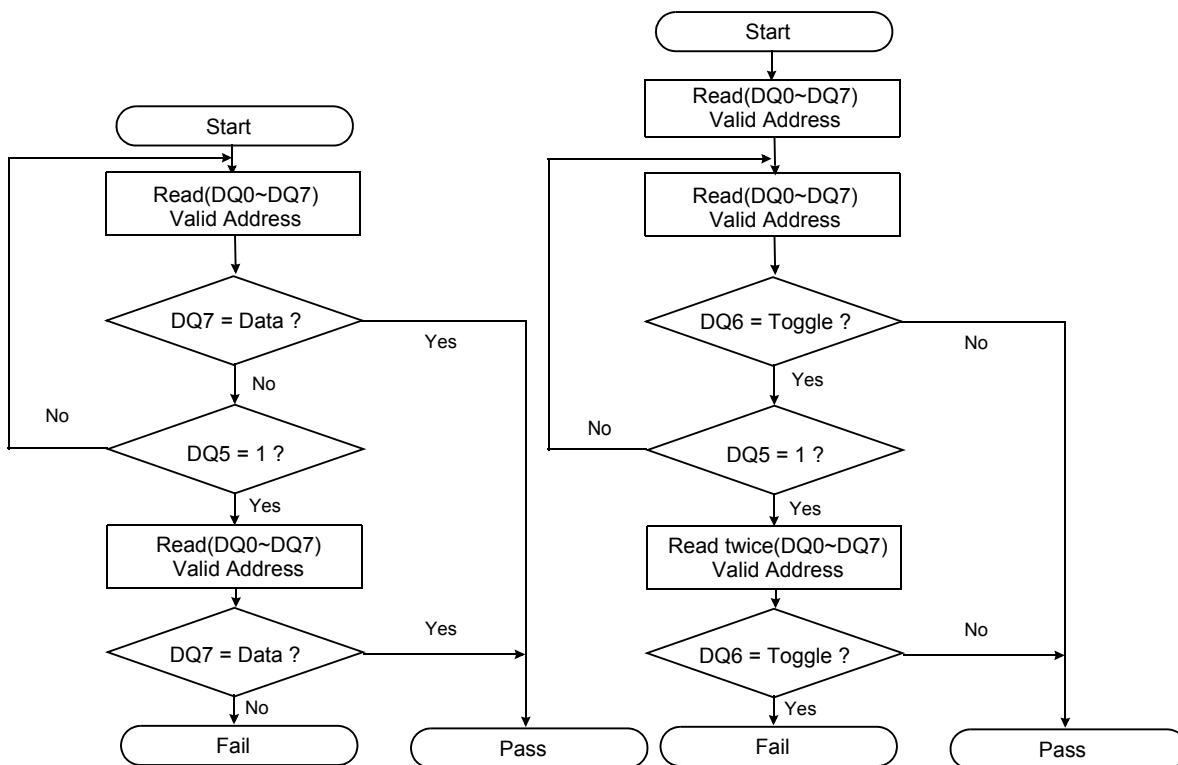

Figure 10: Data Polling Algorithms

Figure 11: Toggle Bit Algorithms

## 15.0 ABSOLUTE MAXIMUM RATINGS

Parameter	Symbol	Rating	Unit
Voltage on any pin relative to Vss	V <sub>CC</sub>	-0.5 to +4.0	V
	V <sub>IO</sub>	-0.5 to +4.0	
	$\overline{WP}/ACC$	-0.5 to +9.5	
	All Other Pins	-0.5 to V <sub>CC</sub> +0.5	
Temperature Under Bias	T <sub>bias</sub>	Commercial	-10 to +125
		Extended	-25 to +125
Storage Temperature	T <sub>stg</sub>	-65 to +150	°C
Short Circuit Output Current	I <sub>OS</sub>	5	mA
Operating Temperature	T <sub>A</sub> (Industrial Temp.)	-40 to +85	°C
	T <sub>A</sub> (Extended Temp.)	-25 to +85	°C

### NOTE :

- 1) Minimum DC voltage is -0.5V on Input/ Output pins. During transitions, this level may fall to -2.0V for periods <20ns. Maximum DC voltage on input / output pins is V<sub>CC</sub>+0.5V which, during transitions, may overshoot to V<sub>CC</sub>+2.0V for periods <20ns.
- 2) Minimum DC voltage is -0.5V on  $\overline{WP}/ACC$  pins. During transitions, this level may fall to -2.0V for periods <20ns. Maximum DC voltage on  $\overline{WP}/ACC$  pins is 9.5V which, during transitions, may overshoot to 10.5V for periods <20ns.
- 3) Permanent device damage may occur if ABSOLUTE MAXIMUM RATINGS are exceeded. Functional operation should be restricted to the conditions detailed in the operational sections of this data sheet. Exposure to absolute maximum rating conditions for extended periods may affect reliability.

## 16.0 RECOMMENDED OPERATING CONDITIONS (Voltage reference to GND)

Parameter	Symbol	Min	Typ.	Max	Unit
Supply Voltage	V <sub>CC</sub>	2.7	3.0	3.6	V
V <sub>IO</sub> Supply Voltage	V <sub>IO</sub>	1.65	-	V <sub>CC</sub>	V
Supply Voltage	V <sub>SS</sub>	0	0	0	V

## 17.0 DC CHARACTERISTICS

Parameter	Symbol	Test Conditions	Min	Typ	Max	Unit
Input Leakage Current	I <sub>LI</sub>	V <sub>IN</sub> =V <sub>SS</sub> to V <sub>CC</sub> , V <sub>CC</sub> =V <sub>CCmax</sub>	- 1.0	-	+ 1.0	μA
Output Leakage Current	I <sub>LO</sub>	V <sub>OUT</sub> =V <sub>SS</sub> to V <sub>CC</sub> , V <sub>CC</sub> =V <sub>CCmax</sub>	- 1.0	-	+ 1.0	μA
V <sub>CC</sub> Active Read Current <sup>1)</sup>			TBD		TBD	TBD
V <sub>IO</sub> Non-Active Output			TBD		TBD	TBD
Active Write Current <sup>2)</sup>	I <sub>CC2</sub>	CE=V <sub>IL</sub> , OE=V <sub>IH</sub> , WE=V <sub>IL</sub>	-	25	50	mA
Program While Erase Suspend Current	I <sub>CC5</sub>	$\overline{CE}=V_{IL}, \overline{OE}=V_{IH}$	-	27	55	mA
Page Read Current	I <sub>CC6</sub>	$\overline{OE}=V_{IH}$ , 8-word Page Read   40MHz	-	10	15	mA
ACC Accelerated Program Current	I <sub>ACC</sub>	$\overline{CE}=V_{IL}, \overline{OE}=V_{IH}$	-	15	30	mA
Standby Current	I <sub>SB1</sub>	$\overline{CE}, \overline{RESET}, \overline{WP}/ACC=V_{CC} \pm 0.3$	-	20	40	μA
Standby Current During Reset	I <sub>SB2</sub>	$\overline{RESET}=V_{SS} \pm 0.3$	-	20	40	μA
Automatic Sleep Mode	I <sub>SB3</sub>	V <sub>IH</sub> =V <sub>CC</sub> ± 0.3V, V <sub>IL</sub> =V <sub>SS</sub> ± 0.2V	-	20	40	μA
Input Low Level	V <sub>IL</sub>	V <sub>CC</sub> =2.7~3.6V	-0.5	-	0.8	V
Input High Level	V <sub>IH</sub>	V <sub>CC</sub> =2.7~3.6V	V <sub>CC</sub> ×0.7	-	V <sub>CC</sub> +0.3	V
Voltage for Program Acceleration <sup>4)</sup>	V <sub>HH</sub>	V <sub>CC</sub> = 2.7~3.6V	8.5	-	9.5	V
Voltage for Autoselect and Temporary Sector Unprotect	V <sub>ID</sub>	V <sub>CC</sub> = 2.7~3.6V	8.5	-	9.5	V
Output Low Level	V <sub>OL</sub>	I <sub>OL</sub> = 100μA, V <sub>CC</sub> =V <sub>CCmin</sub>	-	-	0.1	V
Output High Level	V <sub>OH</sub>	I <sub>OH</sub> = -100μA, V <sub>CC</sub> =V <sub>CCmin</sub>	V <sub>CC</sub> - 0.2	-	-	V
Low VCC Lock-out Voltage <sup>5)</sup>	V <sub>LKO</sub>		2.3	-	2.5	V

**NOTE :**

- 1) The I<sub>CC</sub> current listed includes both the DC operating current and the frequency dependent component(at 5 MHz).  
 2) I<sub>CC</sub> active during Internal Routine(program or erase) is in progress..  
 3) The high voltage (V<sub>HH</sub>) must be used in the range of V<sub>CC</sub> = 2.7V ~ 3.6V  
 4.)Not 100% tested.

### 17.1 CAPACITANCE (T<sub>A</sub> = 25 °C, V<sub>CC</sub> = 3.0V, f = 1.0MHz)

Item	Symbol	Test Condition	Min	Max	Unit
Input Capacitance	C <sub>IN</sub>	V <sub>IN</sub> =0V	-	10	pF
Output Capacitance	C <sub>OUT</sub>	V <sub>OUT</sub> =0V	-	10	pF
Control Pin Capacitance	C <sub>IN2</sub>	V <sub>IN</sub> =0V	-	10	pF

**NOTE :** Capacitance is periodically sampled and not 100% tested.



## 18.0 AC TEST CONDITION

Parameter	Value
Input Pulse Levels	0V to Vcc
Input Rise and Fall Times	5ns
Input and Output Timing Levels	Vcc/2
Output Load	CL = 30pF

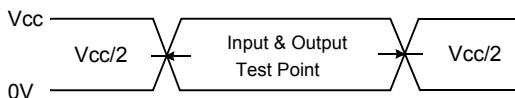

Input Pulse and Test Point

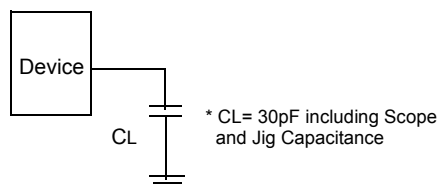

Output Load

## 19.0 AC CHARACTERISTICS

### 19.1 Read Operations

Parameter	Symbol	Vcc = 2.7V~3.6V		Unit
		4E		
		Min	Max	
Read Cycle Time <sup>1)</sup>	t <sub>RC</sub>	80	-	ns
Page Read Cycle Time	t <sub>PRC</sub>	30	-	ns
Address Access Time	t <sub>AA</sub>	-	80	ns
Chip Enable Access Time	t <sub>CE</sub>	-	80	ns
Output Enable Time	t <sub>OE</sub>	-	30	ns
Page Address Access Time	t <sub>PA</sub>	-	30	ns
$\overline{CE}$ & $\overline{OE}$ Disable Time <sup>1)</sup>	t <sub>DF</sub>	-	16	ns
Output Hold Time from Address, $\overline{CE}$ or $\overline{OE}$ <sup>1)</sup>	t <sub>OH</sub>	5	-	ns

NOTE :  
1) Not 100% tested.

**SWITCHING WAVEFORMS**  
**Conventional Read Operations**

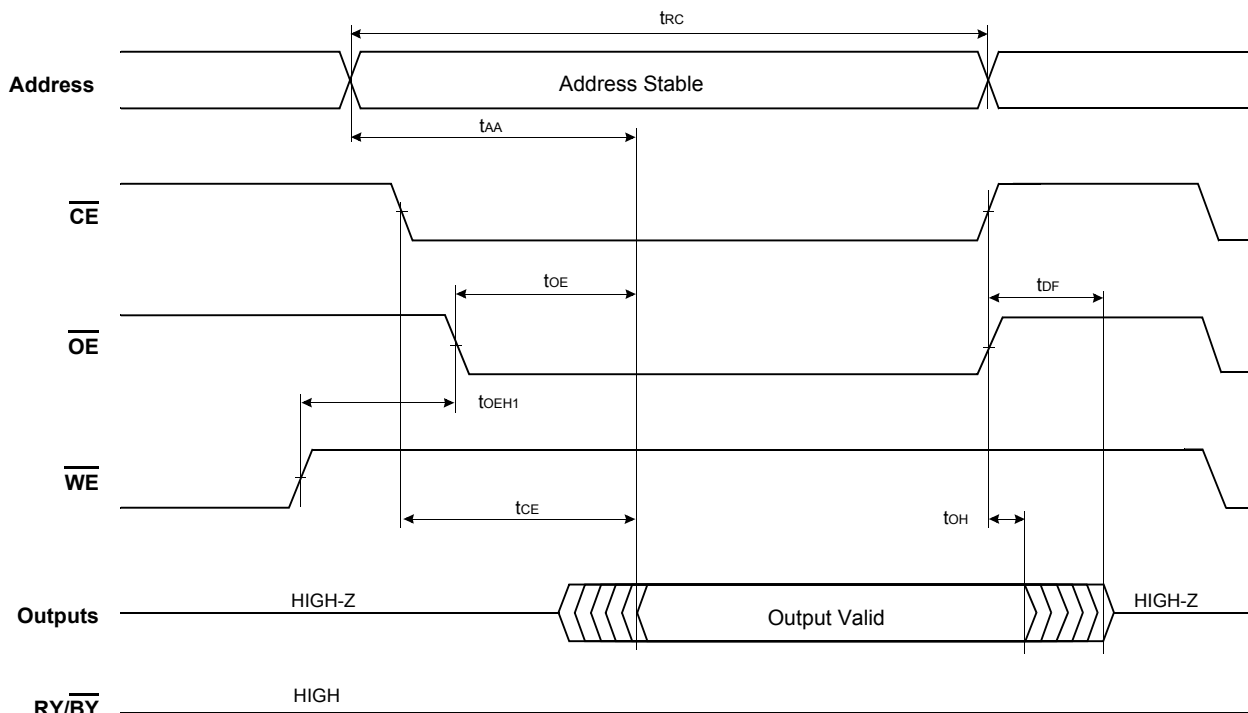

Figure 12: Conventional Read Operation Timings

**Page Read Operations**

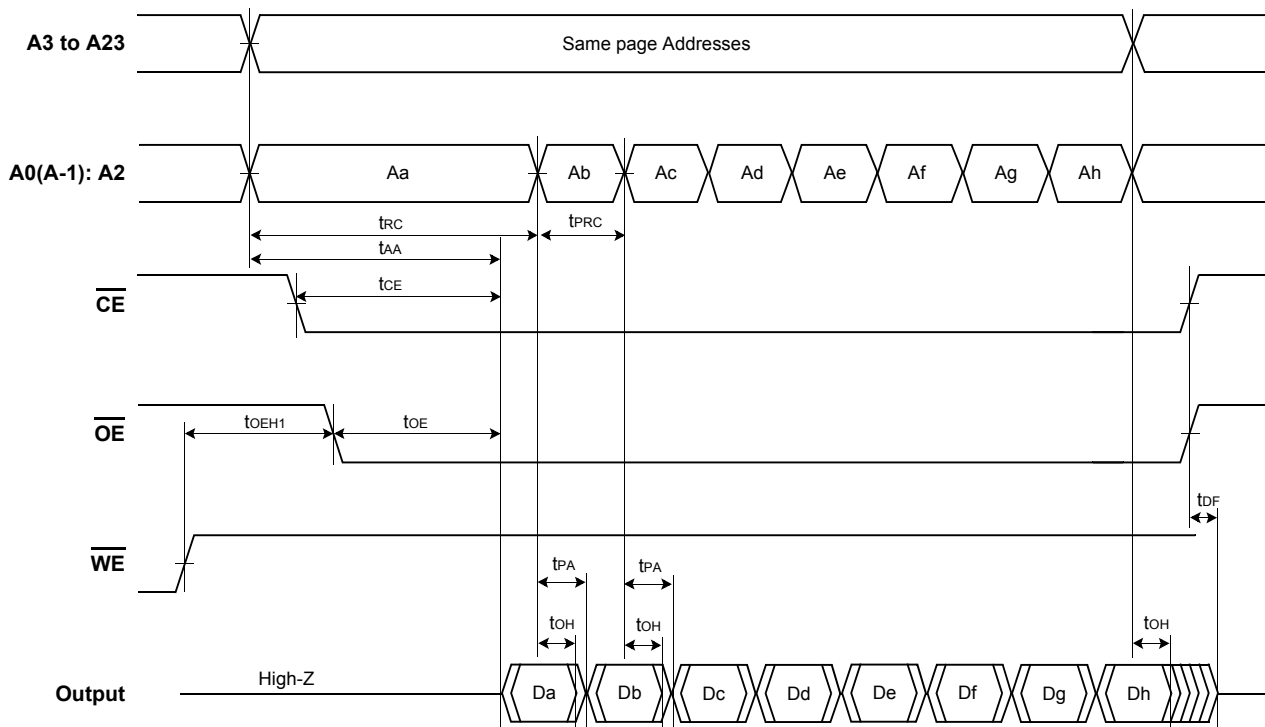

Figure 13: Page Read Operation Timings

**SWITCHING WAVEFORMS**  
**Hardware Reset/Read Operations**

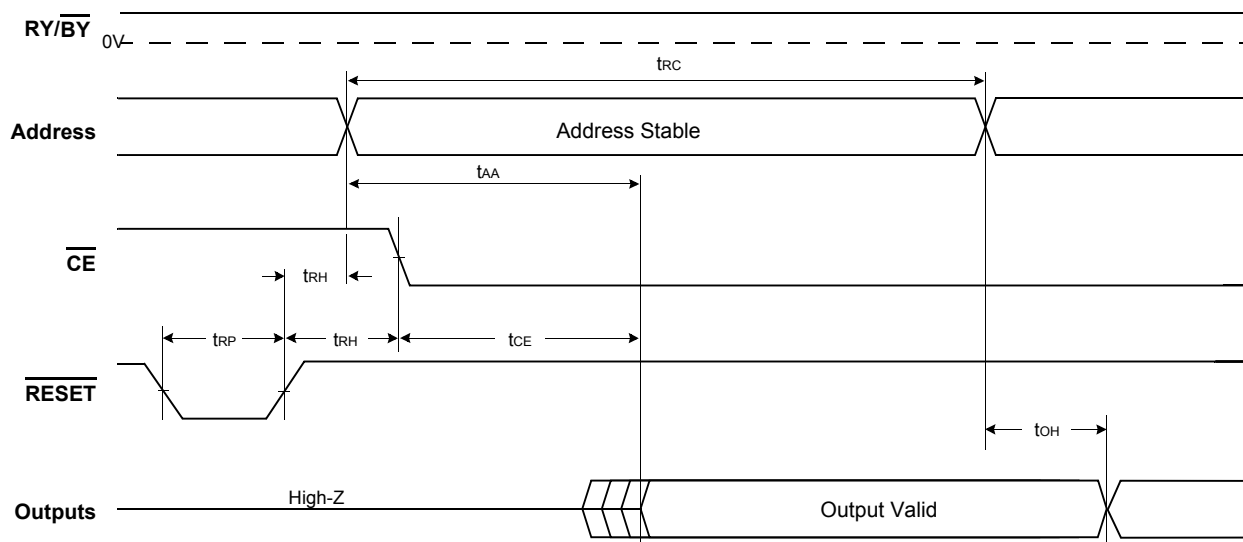

Figure 14: Hardware Reset/Read Operation Timings

Parameter	Symbol	4E		Unit
		Min	Max	
Read Cycle Time	t <sub>RC</sub>	80	-	ns
Address Access Time	t <sub>AA</sub>	-	80	ns
Chip Enable Access Time	t <sub>CE</sub>	-	80	ns
Output Hold Time from Address, $\overline{CE}$ or $\overline{OE}$	t <sub>OH</sub>	5	-	ns
RY/BY Recovery Time	t <sub>RB</sub>	0	-	ns
$\overline{RESET}$ Low to Standby Mode	t <sub>RPD</sub>	20	-	μs
$\overline{RESET}$ Pulse Width	t <sub>RP</sub>	30	-	μs
$\overline{RESET}$ High Time Before Read	t <sub>RH</sub>	200	-	ns

## AC CHARACTERISTICS

## 19.2 Write(Erase/Program)Operations

Parameter	Symbol	VCC = 2.7V ~ 3.6V		Unit
		4E		
		Min	Max	
Write Cycle Time <sup>1), 3)</sup>	$t_{WC}$	80	-	ns
Address Setup Time	$t_{AS}$	0	-	ns
Address Setup Time to $\overline{OE}$ low during toggle bit polling	$t_{ASO}$	15	-	ns
Address Hold Time	$t_{AH}$	35	-	ns
	$t_{AHT}$	0	-	ns
Data Setup Time	$t_{DS}$	30	-	ns
Data Hold Time	$t_{DH}$	0	-	ns
Output Enable Setup Time <sup>1)</sup>	$t_{OES}$	0	-	ns
Output Enable Hold Time	Read <sup>1)</sup>	$t_{OE1}$	-	ns
	Toggle and $\overline{Data}$ Polling <sup>1)</sup>	$t_{OE2}$	-	ns
$\overline{CE}$ Setup Time	$t_{CS}$	0	-	ns
$\overline{CE}$ Hold Time	$t_{CH}$	0	-	ns
Write Pulse Width	$t_{WP}$	35	-	ns
Write Pulse Width High	$t_{WPH}$	25	-	ns
Programming Operation <sup>2)</sup>	$t_{PGM}$	40(typ.)		$\mu$ s
Accelerated Programming Operation <sup>2)</sup>	$t_{ACCPGM}$	24(typ.)		$\mu$ s
Block Erase Operation <sup>2)</sup>	$t_{BERS}$	0.7(typ)		sec
VCC Set Up Time	$t_{VCS}$	250	-	$\mu$ s
VHH Set Up Time	$t_{VHH}$	250	-	ns
ACC Setup Time (During Accelerated Programming)	$t_{VPS}$	1	-	us
Write Recovery Time from $\overline{RY}/\overline{BY}$	$t_{RB}$	0	-	ns
Program/Erase Valid to $\overline{RY}/\overline{BY}$ Delay	$t_{BUSY}$	-	90	ns
Read Recovery Time Before Write	$t_{GHWL}$	0	-	ns
$\overline{CE}$ High during toggling bit polling	$t_{CEPH}$	20	-	ns
$\overline{OE}$ High during toggling bit polling	$t_{OEPH}$	10	-	ns
Block Erase Accept Time-out	$t_{BEA}$	-	50	us
Erase Suspend Latency	$t_{ESL}$	-	20	us
Program Suspend Latency	$t_{PSL}$	-	10	us
Toggle Time During Block Protection	$t_{ASP}$	100(typ)		us
Toggle Time During Programming Within a Protected Block	$t_{PSP}$	1(typ)		us

## NOTE :

1) Not 100% tested.

2) The duration of the Program or Erase operation varies and is calculated in the internal algorithms.

3)  $t_{WC}$  : 80ns(min) : 4E option

## 20.0 ERASE AND PROGRAM PERFORMANCE

Parameter		Condition	Limits			Unit	Comments
			Min	Typ	Max		
Block Erase Time	64 Kword	V <sub>CC</sub>	-	0.7	3.5	sec	Includes 00H programming prior to erasure
		A <sub>CC</sub>		TBD			
Chip Erase Time		V <sub>CC</sub>	-	179.2		sec	Includes 00H programming prior to erasure
		A <sub>CC</sub>		TBD			
Word Programming Time		V <sub>CC</sub>	-	40	400	μs	Excludes system-level overhead
		A <sub>CC</sub>		24	240		
Word Programming time with 32-words Buffer		V <sub>CC</sub>	-	9.4	94	μs	Excludes system-level overhead
		A <sub>CC</sub>		6	60		
Total 32-words Buffer Programming Time		V <sub>CC</sub>	-	300	3000	μs	Excludes system-level overhead
		A <sub>CC</sub>		192	1920		
Chip Programming Time with 32-word Buffer		V <sub>CC</sub>	-	157.3	315	sec	Excludes system-level overhead

**NOTE :**

- 1) 25 °C, V<sub>CC</sub> = 3.0V 100,000 cycles, Typical (Checkerboard pattern), All values are subject to change.
- 2) System-level overhead is defined as the time required to execute the four bus cycle command necessary to program each word. In the preprogramming step of the Internal Erase Routine, all words are programmed to 00H before erasure.

### SWITCHING WAVEFORMS Program Operations

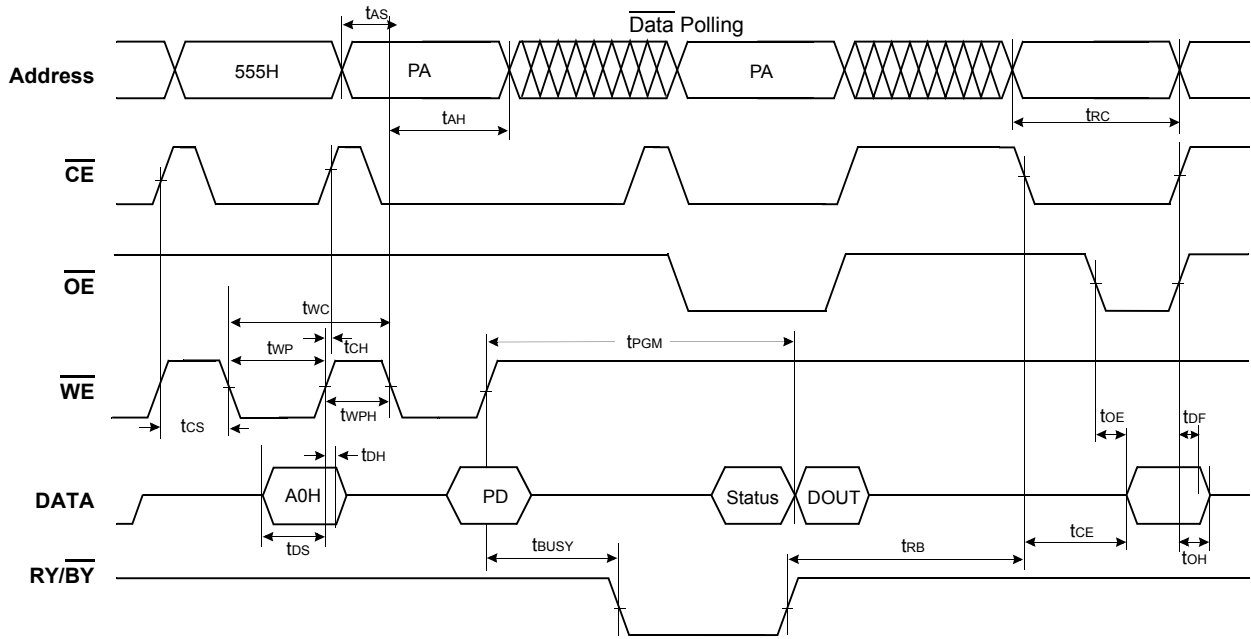

- NOTE :**
- 1)  $\overline{DQ7}$  is the output of the complement of the data written to the device.
  - 2)  $\overline{DOUT}$  is the output of the data written to the device.
  - 3) PA : Program Address, PD : Program Data
  - 4) The illustration shows the last two cycles of the program command sequence.

Figure 15: Program Operation Timings

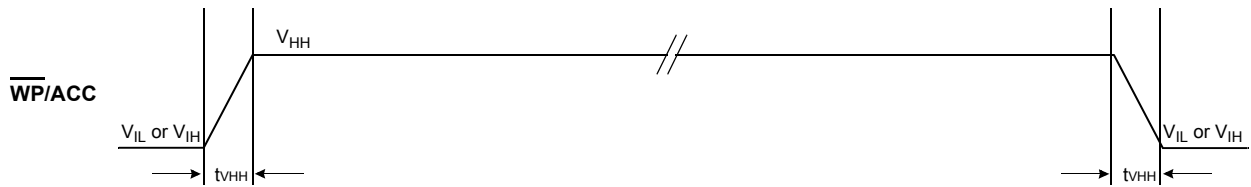

Figure 16: Accelerated Program Timings

**SWITCHING WAVEFORMS**  
**Chip/Block Erase Operations**

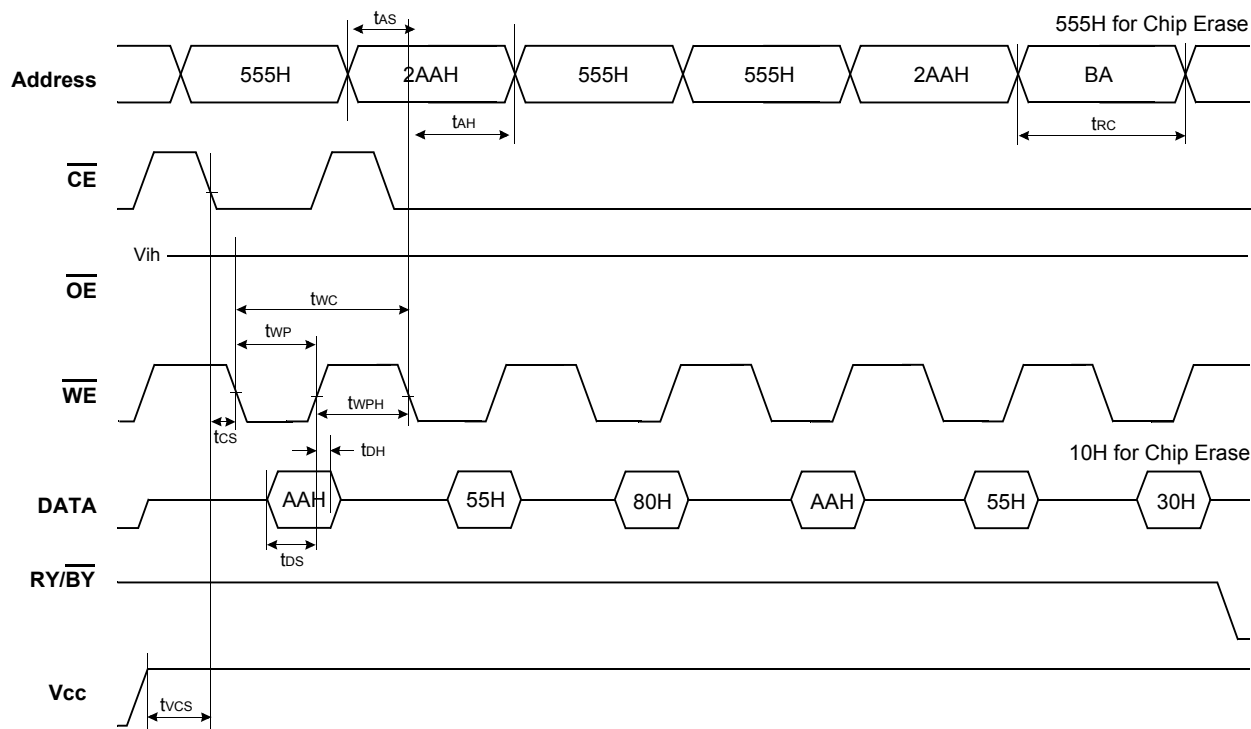
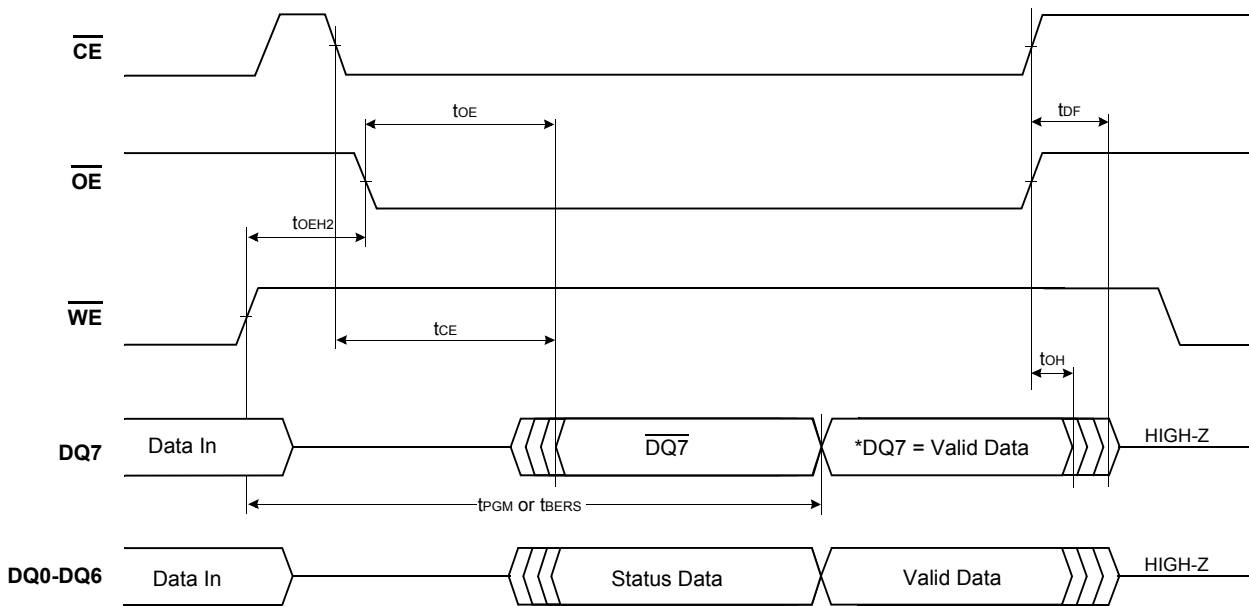

Figure 17: Chip/Block Erase Operation Timings

**NOTE :**  
 1) BA : Block Address

**SWITCHING WAVEFORMS**

**Data Polling During Internal Routine Operation**



**NOTE :**  
 DQ7=Vaild Data (The device has completed the internal operation).

**Figure 18: Data Polling During Internal Routine Operation Timings**

**RY/BY Timing Diagram During Program/Erase Operation**

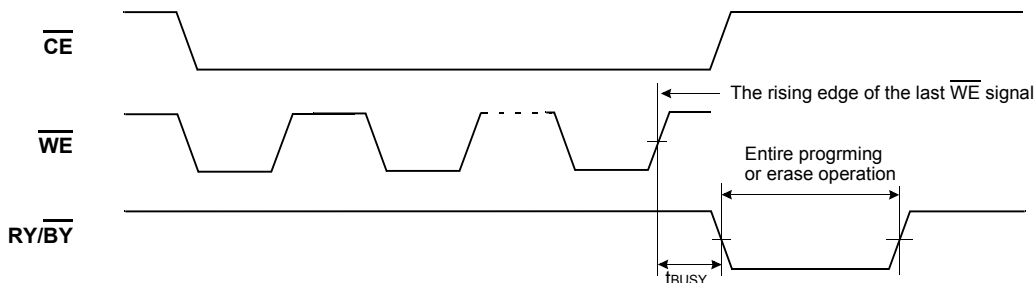
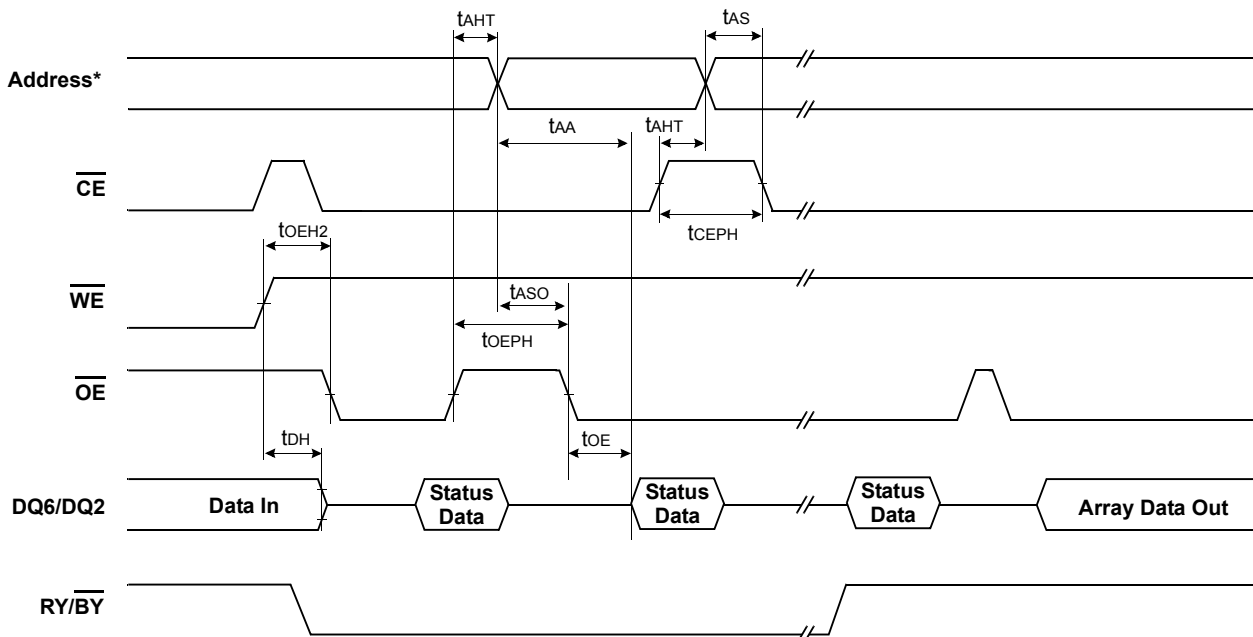

**Figure 19: RY/BY Timing Diagram During Program/Erase Operation Timings**

Parameter	Symbol	4E		Unit
		Min	Max	
Program/Erase Valid to RY/BY Delay	tBUSY	-	90	ns
Chip Enable Access Time	tCE	-	80	ns
Output Enable Time	tOE	-	30	ns
CE & OE Disable Time	tDF	-	16	ns
Output Hold Time from Address, CE or OE	tOH	5	-	ns
OE Hold Time	tOE2	10	-	ns



**SWITCHING WAVEFORMS**  
**Toggle Bit During Internal Routine Operation**



**NOTE :**  
 A = Valid Address ; Not required for DQ6. The switching waveform shows first two status cycle after command sequence, last status read cycle, and array data read cycle CE does not need to go high between status bit reads.

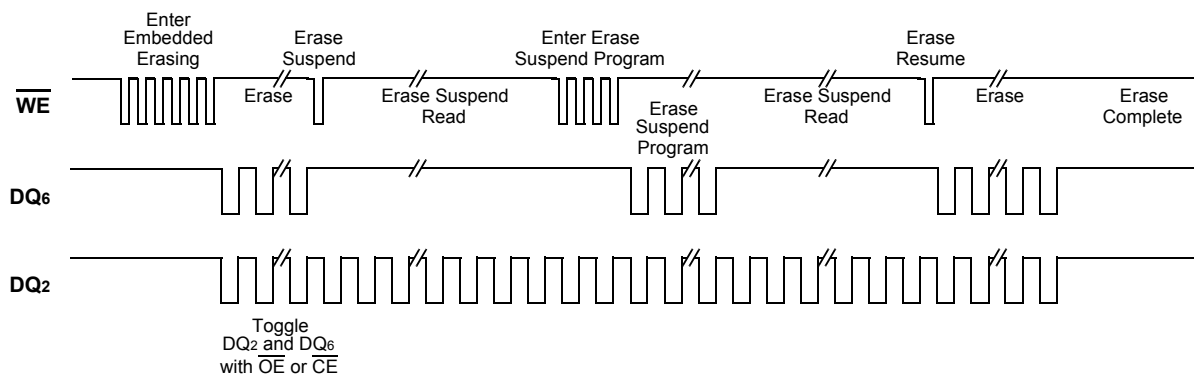

**NOTE :** DQ2 is read from the erase-suspended block.

**Figure 20: Toggle Bit During Internal Routine Operation Timings**

**SWITCHING WAVEFORMS**

**RESET Timing Diagram**

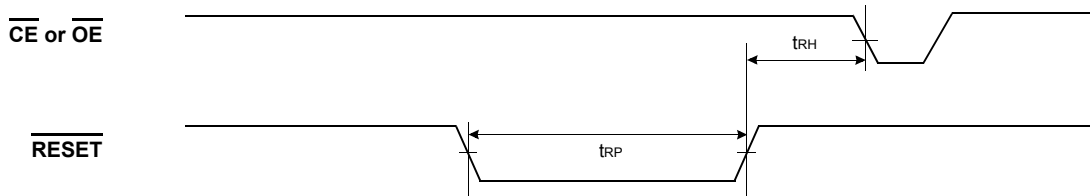

**Power-up and  $\overline{RESET}$  Timing Diagram**

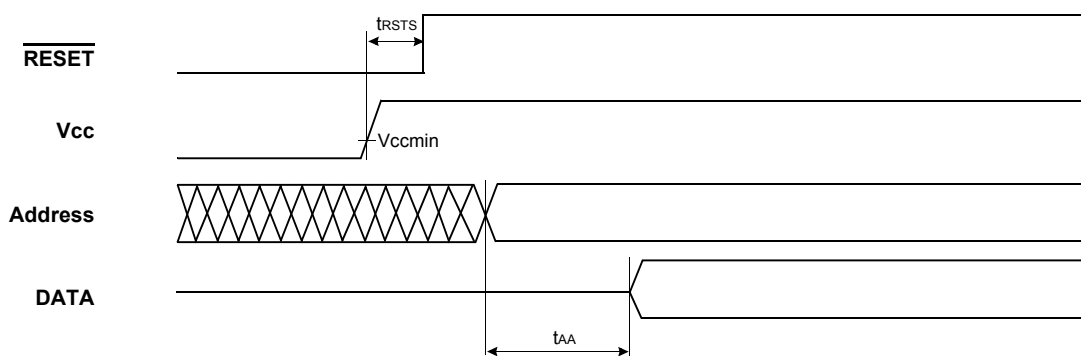
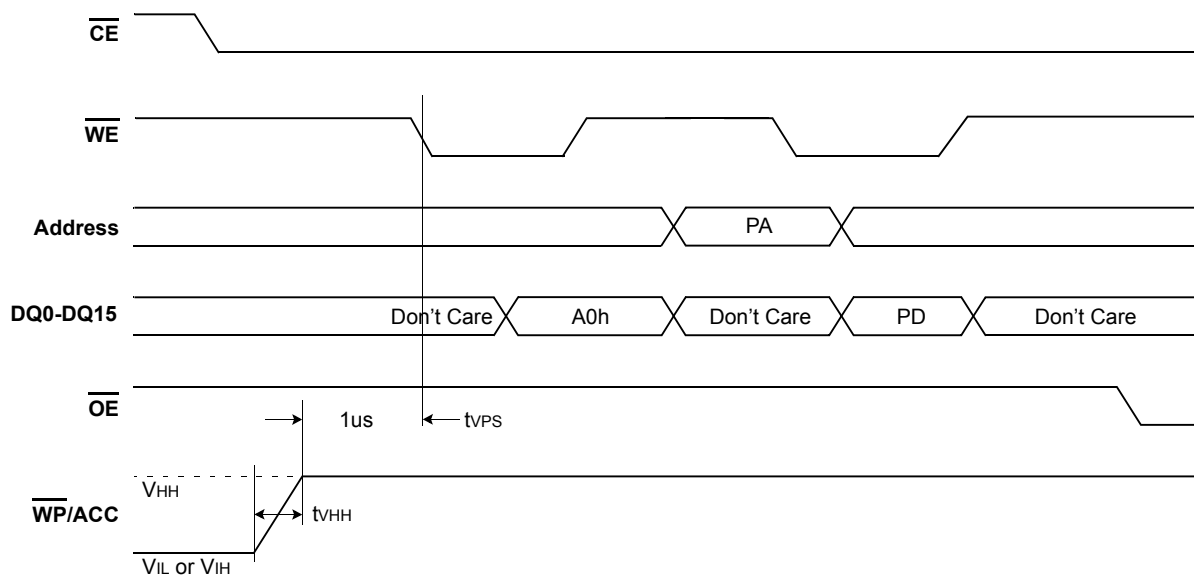

Figure 21: Power-up and  $\overline{RESET}$  Timing Diagram

Parameter	Symbol	All Speed		Unit
		Min	Max	
$\overline{RESET}$ Pulse Width	$t_{RP}$	30	-	$\mu S$
$\overline{RESET}$ High Time Before Read	$t_{RH}$	200	-	nS
$\overline{RESET}$ Low Set-up Time	$t_{RSTS}$	250	-	$\mu S$

**SWITCHING WAVEFORMS**  
**Unlock Bypass Program Operations(Accelerated Program)**



**Unlock Bypass Block Erase Operations(Accelerated Program)**

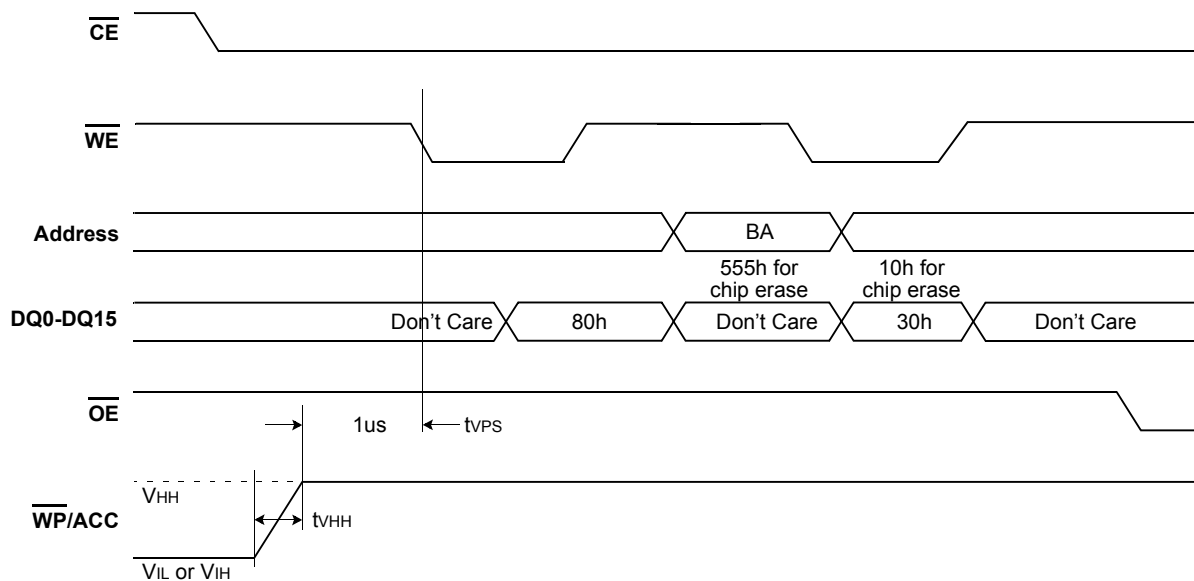

- NOTE :**
- 1) VHH can be left high for subsequent programming pulses.
  - 2) Use setup and hold times from conventional program operations.
  - 3) Unlock Bypass Program/Erase commands can be used when the VHH is applied to  $\overline{WP/ACC}$

Figure 22: Unlock Bypass Operation Timings

[Table 15] Address Table

Block	Block Size	(x16) Address Range
BA255	64 kwords	FF0000h-FFFFFFh
BA254	64 kwords	FE0000h-FEFFFFh
BA253	64 kwords	FD0000h-FDFFFFh
BA252	64 kwords	FC0000h-FCFFFFh
BA251	64 kwords	FB0000h-FBFFFFh
BA250	64 kwords	FA0000h-FAFFFFh
BA249	64 kwords	F90000h-F9FFFFh
BA248	64 kwords	F80000h-F8FFFFh
BA247	64 kwords	F70000h-F7FFFFh
BA246	64 kwords	F60000h-F6FFFFh
BA245	64 kwords	F50000h-F5FFFFh
BA244	64 kwords	F40000h-F4FFFFh
BA243	64 kwords	F30000h-F3FFFFh
BA242	64 kwords	F20000h-F2FFFFh
BA241	64 kwords	F10000h-F1FFFFh
BA240	64 kwords	F00000h-F0FFFFh
BA239	64 kwords	EF0000h-EFFFFFh
BA238	64 kwords	EE0000h-EEFFFFh
BA237	64 kwords	ED0000h-EDFFFFh
BA236	64 kwords	EC0000h-ECFFFFh
BA235	64 kwords	EB0000h-EBFFFFh
BA234	64 kwords	EA0000h-EAFFFFh
BA233	64 kwords	E90000h-E9FFFFh
BA232	64 kwords	E80000h-E8FFFFh
BA231	64 kwords	E70000h-E7FFFFh
BA230	64 kwords	E60000h-E6FFFFh
BA229	64 kwords	E50000h-E5FFFFh
BA228	64 kwords	E40000h-E4FFFFh
BA227	64 kwords	E30000h-E3FFFFh
BA226	64 kwords	E20000h-E2FFFFh
BA225	64 kwords	E10000h-E1FFFFh
BA224	64 kwords	E00000h-E0FFFFh
BA223	64 kwords	DF0000h-DFFFFFh
BA222	64 kwords	DE0000h-DEFFFFh
BA221	64 kwords	DD0000h-DDFFFFh
BA220	64 kwords	DC0000h-DCFFFFh
BA219	64 kwords	DB0000h-DBFFFFh
BA218	64 kwords	DA0000h-DAFFFFh
BA217	64 kwords	D90000h-D9FFFFh
BA216	64 kwords	D80000h-D8FFFFh
BA215	64 kwords	D70000h-D7FFFFh
BA214	64 kwords	D60000h-D6FFFFh

Block	Block Size	(x16) Address Range
BA213	64 kwords	D50000h-D5FFFFh
BA212	64 kwords	D40000h-D4FFFFh
BA211	64 kwords	D30000h-D3FFFFh
BA210	64 kwords	D20000h-D2FFFFh
BA209	64 kwords	D10000h-D1FFFFh
BA208	64 kwords	D00000h-D0FFFFh
BA207	64 kwords	CF0000h-CFFFFFh
BA206	64 kwords	CE0000h-CEFFFFh
BA205	64 kwords	CD0000h-CDFFFFh
BA204	64 kwords	CC0000h-CCFFFFh
BA203	64 kwords	CB0000h-CBFFFFh
BA202	64 kwords	CA0000h-CAFFFFh
BA201	64 kwords	C90000h-C9FFFFh
BA200	64 kwords	C80000h-C8FFFFh
BA199	64 kwords	C70000h-C7FFFFh
BA198	64 kwords	C60000h-C6FFFFh
BA197	64 kwords	C50000h-C5FFFFh
BA196	64 kwords	C40000h-C4FFFFh
BA195	64 kwords	C30000h-C3FFFFh
BA194	64 kwords	C20000h-C2FFFFh
BA193	64 kwords	C10000h-C1FFFFh
BA192	64 kwords	C00000h-C0FFFFh
BA191	64 kwords	BF0000h-BFFFFFh
BA190	64 kwords	BE0000h-BEFFFFh
BA189	64 kwords	BD0000h-BDFFFFh
BA188	64 kwords	BC0000h-BCFFFFh
BA187	64 kwords	BB0000h-BBFFFFh
BA186	64 kwords	BA0000h-BAFFFFh
BA185	64 kwords	B90000h-B9FFFFh
BA184	64 kwords	B80000h-B8FFFFh
BA183	64 kwords	B70000h-B7FFFFh
BA182	64 kwords	B60000h-B6FFFFh
BA181	64 kwords	B50000h-B5FFFFh
BA180	64 kwords	B40000h-B4FFFFh
BA179	64 kwords	B30000h-B3FFFFh
BA178	64 kwords	B20000h-B2FFFFh
BA177	64 kwords	B10000h-B1FFFFh
BA176	64 kwords	B00000h-B0FFFFh
BA175	64 kwords	AF0000h-AFFFFFh
BA174	64 kwords	AE0000h-AEFFFFh
BA173	64 kwords	AD0000h-ADFFFFh
BA172	64 kwords	AC0000h-ACFFFFh
BA171	64 kwords	AB0000h-ABFFFFh
BA170	64 kwords	AA0000h-AAFFFFh
BA169	64 kwords	A90000h-A9FFFFh

Block	Block Size	(x16) Address Range
BA168	64 kwords	A80000h-A8FFFFh
BA167	64 kwords	A70000h-A7FFFFh
BA166	64 kwords	A60000h-A6FFFFh
BA165	64 kwords	A50000h-A5FFFFh
BA164	64 kwords	A40000h-A4FFFFh
BA163	64 kwords	A30000h-A3FFFFh
BA162	64 kwords	A20000h-A2FFFFh
BA161	64 kwords	A10000h-A1FFFFh
BA160	64 kwords	A00000h-A0FFFFh
BA159	64 kwords	9F0000h-9FFFFFh
BA158	64 kwords	9E0000h-9EFFFFh
BA157	64 kwords	9D0000h-9DFFFFh
BA156	64 kwords	9C0000h-9CFFFFh
BA155	64 kwords	9B0000h-9BFFFFh
BA154	64 kwords	9A0000h-9AFFFFh
BA153	64 kwords	990000h-99FFFFh
BA152	64 kwords	980000h-98FFFFh
BA151	64 kwords	970000h-97FFFFh
BA150	64 kwords	960000h-96FFFFh
BA149	64 kwords	950000h-95FFFFh
BA148	64 kwords	940000h-94FFFFh
BA147	64 kwords	930000h-93FFFFh
BA146	64 kwords	920000h-92FFFFh
BA145	64 kwords	910000h-91FFFFh
BA144	64 kwords	900000h-90FFFFh
BA143	64 kwords	8F0000h-8FFFFFh
BA142	64 kwords	8E0000h-8EFFFFh
BA141	64 kwords	8D0000h-8DFFFFh
BA140	64 kwords	8C0000h-8CFFFFh
BA139	64 kwords	8B0000h-8BFFFFh
BA138	64 kwords	8A0000h-8AFFFFh
BA137	64 kwords	890000h-89FFFFh
BA136	64 kwords	880000h-88FFFFh
BA135	64 kwords	870000h-87FFFFh
BA134	64 kwords	860000h-86FFFFh
BA133	64 kwords	850000h-85FFFFh
BA132	64 kwords	840000h-84FFFFh
BA131	64 kwords	830000h-83FFFFh
BA130	64 kwords	820000h-82FFFFh
BA129	64 kwords	810000h-81FFFFh
BA128	64 kwords	800000h-80FFFFh
BA127	64 kwords	7F0000h-7FFFFFh
BA126	64 kwords	7E0000h-7EFFFFh
BA125	64 kwords	7D0000h-7DFFFFh
BA124	64 kwords	7C0000h-7CFFFFh

Block	Block Size	(x16) Address Range
BA123	64 kwords	7B0000h-7BFFFFh
BA122	64 kwords	7A0000h-7AFFFFh
BA121	64 kwords	790000h-79FFFFh
BA120	64 kwords	780000h-78FFFFh
BA119	64 kwords	770000h-77FFFFh
BA118	64 kwords	760000h-76FFFFh
BA117	64 kwords	750000h-75FFFFh
BA116	64 kwords	740000h-74FFFFh
BA115	64 kwords	730000h-73FFFFh
BA114	64 kwords	720000h-72FFFFh
BA113	64 kwords	710000h-71FFFFh
BA112	64 kwords	700000h-70FFFFh
BA111	64 kwords	6F0000h-6FFFFFh
BA110	64 kwords	6E0000h-6EFFFFh
BA109	64 kwords	6D0000h-6DFFFFh
BA108	64 kwords	6C0000h-6CFFFFh
BA107	64 kwords	6B0000h-6BFFFFh
BA106	64 kwords	6A0000h-6AFFFFh
BA105	64 kwords	690000h-69FFFFh
BA104	64 kwords	680000h-68FFFFh
BA103	64 kwords	670000h-67FFFFh
BA102	64 kwords	660000h-66FFFFh
BA101	64 kwords	650000h-65FFFFh
BA100	64 kwords	640000h-64FFFFh
BA99	64 kwords	630000h-63FFFFh
BA98	64 kwords	620000h-62FFFFh
BA97	64 kwords	610000h-61FFFFh
BA96	64 kwords	600000h-60FFFFh
BA95	64 kwords	5F0000h-5FFFFFh
BA94	64 kwords	5E0000h-5EFFFFh
BA93	64 kwords	5D0000h-5DFFFFh
BA92	64 kwords	5C0000h-5CFFFFh
BA91	64 kwords	5B0000h-5BFFFFh
BA90	64 kwords	5A0000h-5AFFFFh
BA89	64 kwords	590000h-59FFFFh
BA88	64 kwords	580000h-58FFFFh
BA87	64 kwords	570000h-57FFFFh
BA86	64 kwords	560000h-56FFFFh
BA85	64 kwords	550000h-55FFFFh
BA84	64 kwords	540000h-54FFFFh
BA83	64 kwords	530000h-53FFFFh
BA82	64 kwords	520000h-52FFFFh
BA81	64 kwords	510000h-51FFFFh
BA80	64 kwords	500000h-50FFFFh

Block	Block Size	(x16) Address Range
BA79	64 kwords	4F0000h-4FFFFFFh
BA78	64 kwords	4E0000h-4EFFFFFFh
BA77	64 kwords	4D0000h-4DFFFFFFh
BA76	64 kwords	4C0000h-4CFFFFFFh
BA75	64 kwords	4B0000h-4BFFFFFFh
BA74	64 kwords	4A0000h-4AFFFFFFh
BA73	64 kwords	490000h-49FFFFFFh
BA72	64 kwords	480000h-48FFFFFFh
BA71	64 kwords	470000h-47FFFFFFh
BA70	64 kwords	460000h-46FFFFFFh
BA69	64 kwords	450000h-45FFFFFFh
BA68	64 kwords	440000h-44FFFFFFh
BA67	64 kwords	430000h-43FFFFFFh
BA66	64 kwords	420000h-42FFFFFFh
BA65	64 kwords	410000h-41FFFFFFh
BA64	64 kwords	400000h-40FFFFFFh
BA63	64 kwords	3F0000h-3FFFFFFh
BA62	64 kwords	3E0000h-3EFFFFFFh
BA61	64 kwords	3D0000h-3DFFFFFFh
BA60	64 kwords	3C0000h-3CFFFFFFh
BA59	64 kwords	3B0000h-3BFFFFFFh
BA58	64 kwords	3A0000h-3AFFFFFFh
BA57	64 kwords	390000h-39FFFFFFh
BA56	64 kwords	380000h-38FFFFFFh
BA55	64 kwords	370000h-37FFFFFFh
BA54	64 kwords	360000h-36FFFFFFh
BA53	64 kwords	350000h-35FFFFFFh
BA52	64 kwords	340000h-34FFFFFFh
BA51	64 kwords	330000h-33FFFFFFh
BA50	64 kwords	320000h-32FFFFFFh
BA49	64 kwords	310000h-31FFFFFFh
BA48	64 kwords	300000h-30FFFFFFh
BA47	64 kwords	2F0000h-2FFFFFFh
BA46	64 kwords	2E0000h-2EFFFFFFh
BA45	64 kwords	2D0000h-2DFFFFFFh
BA44	64 kwords	2C0000h-2CFFFFFFh
BA43	64 kwords	2B0000h-2BFFFFFFh
BA42	64 kwords	2A0000h-2AFFFFFFh
BA41	64 kwords	290000h-29FFFFFFh
BA40	64 kwords	280000h-28FFFFFFh
BA39	64 kwords	270000h-27FFFFFFh
BA38	64 kwords	260000h-26FFFFFFh
BA37	64 kwords	250000h-25FFFFFFh
BA36	64 kwords	240000h-24FFFFFFh
BA35	64 kwords	230000h-23FFFFFFh



Block	Block Size	(x16) Address Range
BA34	64 kwords	220000h-22FFFFh
BA33	64 kwords	210000h-21FFFFh
BA32	64 kwords	200000h-20FFFFh
BA31	64 kwords	1F0000h-1FFFFFh
BA30	64 kwords	1E0000h-1EFFFFh
BA29	64 kwords	1D0000h-1DFFFFh
BA28	64 kwords	1C0000h-1CFFFFh
BA27	64 kwords	1B0000h-1BFFFFh
BA26	64 kwords	1A0000h-1AFFFFh
BA25	64 kwords	190000h-19FFFFh
BA24	64 kwords	180000h-18FFFFh
BA23	64 kwords	170000h-17FFFFh
BA22	64 kwords	160000h-16FFFFh
BA21	64 kwords	150000h-15FFFFh
BA20	64 kwords	140000h-14FFFFh
BA19	64 kwords	130000h-13FFFFh
BA18	64 kwords	120000h-12FFFFh
BA17	64 kwords	110000h-11FFFFh
BA16	64 kwords	100000h-10FFFFh
BA15	64 kwords	0F0000h-0FFFFFh
BA14	64 kwords	0E0000h-0EFFFFh
BA13	64 kwords	0D0000h-0DFFFFh
BA12	64 kwords	0C0000h-0CFFFFh
BA11	64 kwords	0B0000h-0BFFFFh
BA10	64 kwords	0A0000h-0AFFFFh
BA9	64 kwords	090000h-09FFFFh
BA8	64 kwords	080000h-08FFFFh
BA7	64 kwords	070000h-07FFFFh
BA6	64 kwords	060000h-06FFFFh
BA5	64 kwords	050000h-05FFFFh
BA4	64 kwords	040000h-04FFFFh
BA3	64 kwords	030000h-03FFFFh
BA2	64 kwords	020000h-02FFFFh
BA1	64 kwords	010000h-01FFFFh
BA0	64 kwords	000000h-00FFFFh

# 21.0 PACKAGE DIMENSIONS

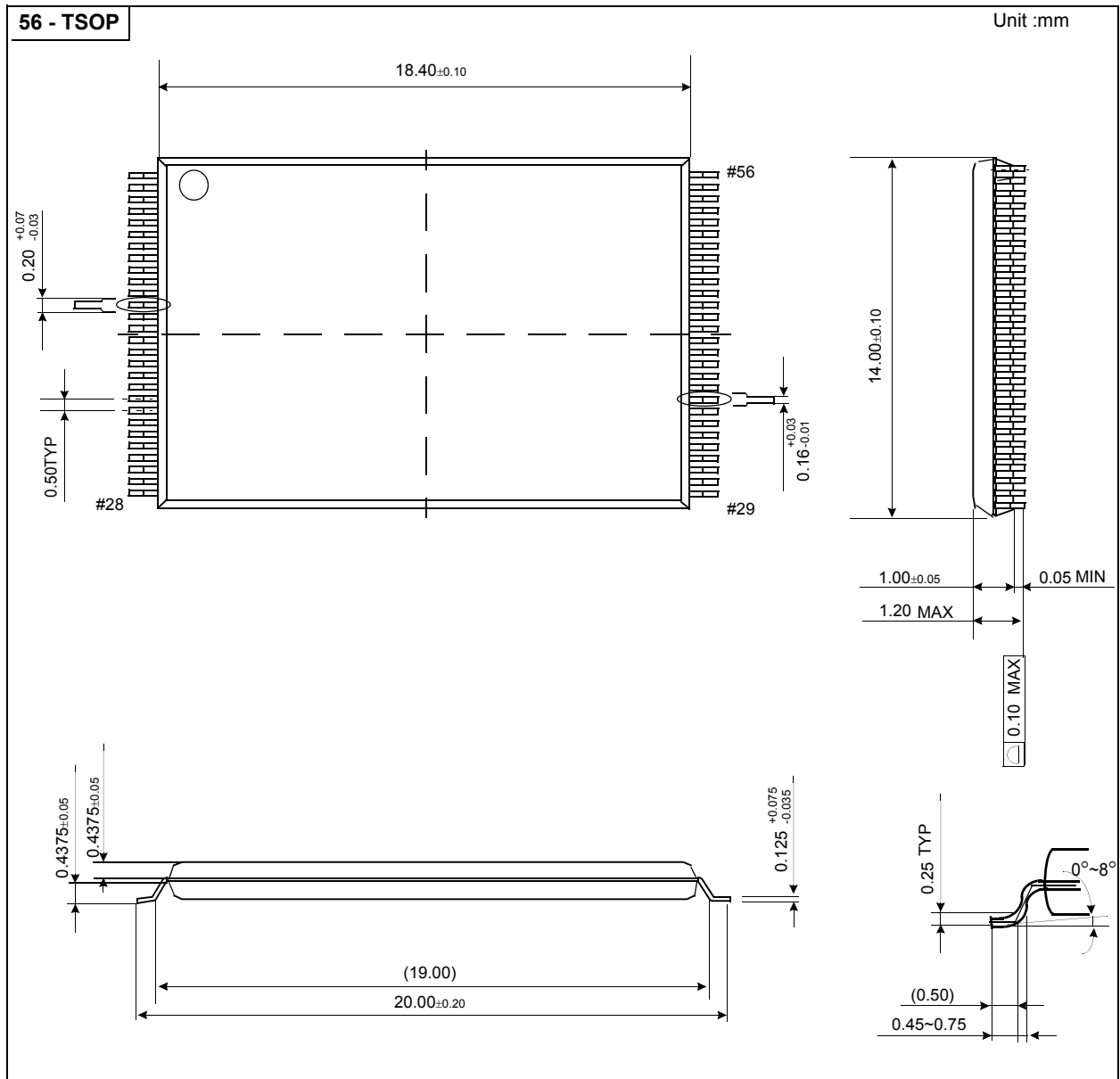

PACKAGE DIMENSIONS

64-Ball Fine Ball Grid Array Package (measured in millimeters)

