



HANDLING SUSPEND MODE ON A USB MOUSE

by Microcontroller Division Application Team

INTRODUCTION

All USB devices must support Suspend mode. Suspend mode enables the devices to enter low-power mode if no bus activity is detected for more than 3.0 ms.

Like USB keyboards and pointing devices, USB mice must be able to exit Suspend mode if a button has been pressed or if a movement has been detected. This feature is called Remote wake-up mode. A Remote wake-up involves a Resume sequence on the USB lines and recovery of communication between the mouse and the host.

The following application note describes the implementation of Suspend and Remote wake-up modes on a USB mouse using the ST7263 microcontroller. The first chapter focuses on the recommendations before entering Suspend mode. Then a description of the RC external circuit for handling Remote wake-up mode is detailed. It contains power management recommendations and RC value proposals. The third chapter describes Resume mode. Then chapter 4 and chapter 5 describe software implementation and program flow.

It is assumed that the reader is familiar with the ST7263 microcontroller and USB.

Table of Contents

INTRODUCTION	1
1 ENTERING SUSPEND MODE	3
1.1 SPECIFICATION	3
1.2 ST7263 IMPLEMENTATION	3
1.3 RECOMMENDATIONS BEFORE ENTERING SUSPEND MODE	3
2 EXITING SUSPEND MODE	4
2.1 SPECIFICATION	4
2.2 ST7263 IMPLEMENTATION	4
2.3 EXTERNAL RC CIRCUIT IMPLEMENTATION	4
2.4 PHOTO TRANSISTORS TIMING REQUIREMENTS	7
2.5 RC TIME CONSTANT CALCULATION	8
3 RESUME MODE	10
4 SOFTWARE IMPLEMENTATION	11
5 PROGRAM FLOW	13
REFERENCE DOCUMENTS	16

1 ENTERING SUSPEND MODE

1.1 SPECIFICATION

The USB mouse must be able to enter Suspend mode from any powered state. It goes into suspend mode when it detects a constant idle state on the USB data lines for more than 3.0 ms. (No Start Of Frames are issued by the Host for more than 3.0 ms). Any bus activity keeps the mouse out of the suspend state.

When the mouse is in the suspend state, it must draw less than 500 μ A from the bus.

1.2 ST7263 IMPLEMENTATION

All the ST7263 microcontroller USB events are managed by interrupts. As soon as a constant idle state occurs for more than 3.0 ms, the SUSPEND bit of the **interrupt status register (ISTR)** is set by hardware. Then, the firmware determines the interrupt origin by reading the ISTR register, sets a bit in a software register (bmUsbIntFlag), and clears the interrupt flag. The USB polling routine reads the software register (bmUsbIntFlag) to determine the USB interrupt source and jumps to the corresponding interrupt routine.

To get the 500 μ A specification, the ST7263 microcontroller must be placed in **HALT low-power mode**. HALT mode is entered by executing the HALT instruction in the SUSPEND interrupt routine. The internal oscillator is then turned off, causing all internal processing to be stopped, including the operation of the on-chip peripherals.

1.3 RECOMMENDATIONS BEFORE ENTERING SUSPEND MODE

Special care must be taken of the ST7263 port configuration before entering Suspend mode.

The Ports A and C contain integrated pull-up resistors. If these Ports are configured as inputs, they draw about 50 μ A on each pin. (See ST7263 Data Sheet electrical characteristics). This means that the 8 Port A pins and the 3 port C pins could draw 550 μ A together. Consequently it would be impossible to get the 500 μ A current consumption specification.

Then Port A and Port C must then be therefor configured as outputs before entering Suspend mode. Correct voltage values must be applied to the output pins to make the current consumption as low as possible.

Port B does not contain any integrated pull-up resistor, but external pull-up resistors are implemented in hardware at the photo transistor outputs. Thus it is strongly recommended to configure these as outputs and to apply a 5V value on each pin before entering Suspend mode.

2 EXITING SUSPEND MODE

2.1 SPECIFICATION

A USB mouse can be woken-up from Suspend state by switching the bus state to the resume state, by normal bus activity, or by signalling a reset. A Mouse device can be woken-up by actions associated with internal functions and then cause signalling on its upstream connections to wake or alert the rest of the system. This feature is called remote wake-up.

2.2 ST7263 IMPLEMENTATION

All the ST7263 microcontroller USB events are managed by interrupts.

The ST7263 microcontroller exits Suspend mode when one of the following events occurs:

a) USB reset on the USB data lines for more than 10 ms min and 20 ms max.

The microcontroller exits Halt mode and jumps to the USB reset interrupt routine.

b) Resume signal on the USB data lines from upstream devices for at least 20 ms.

The microcontroller exits Halt mode and jumps to the USB_end_suspend interrupt routine.

c) External interrupt on a pin of the microcontroller (It can either be a rising or falling edge or a level change). The oscillator is then turned on, the microcontroller exits Halt mode and jumps to the corresponding interrupt routine.

This external interrupt is very important for managing remote wake-up mode. As described in the previous section, when the microcontroller enters HALT mode, it must draw less than 500 μ A average and it must be able to check if a mouse button has been pressed or if the mouse has been moved. This implies that external interrupt must periodically wake-up the microcontroller to make it check its port states.

The following section proposes a cost effective solution for generating this periodic external interrupt.

2.3 EXTERNAL RC CIRCUIT IMPLEMENTATION

During Suspend mode, as the internal oscillator has been turned off, we must use an external event to generate an interrupt on a dedicated pin of the microcontroller. Moreover this interrupt signal must occur periodically.

The most common and cost-effective solution consists of using an external RC circuit.

Figure 1. RC external circuitry

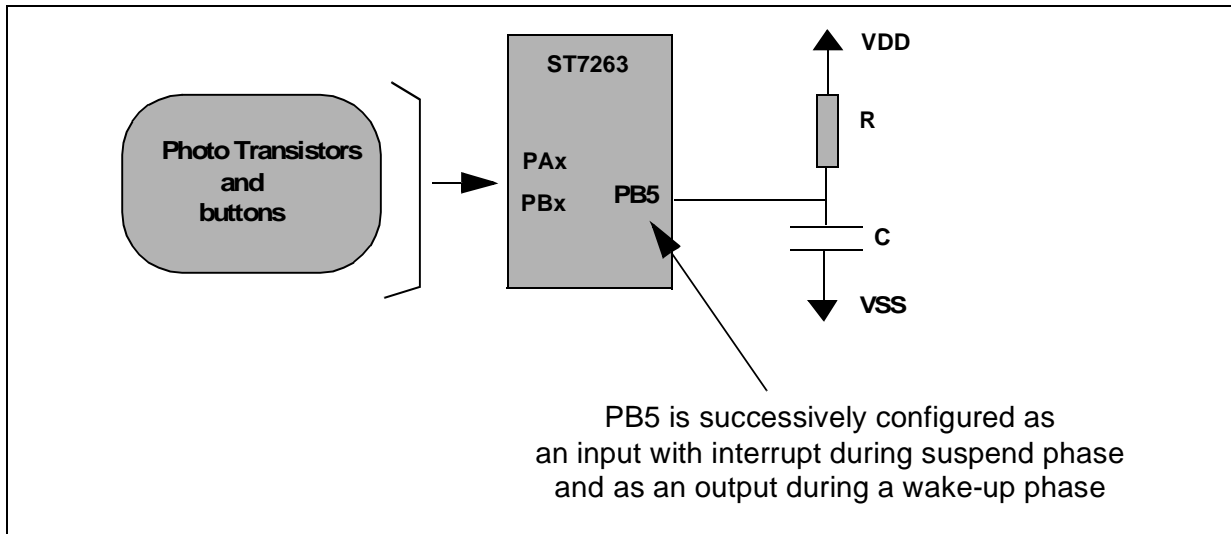

An external capacitor loads through an external resistor. This capacitor is connected to the PB5 external interrupt pin of the microcontroller. As soon as the capacitor load has reached the Low-to-High trigger level, the external interrupt vector is set. Then, the entire microcontroller is woken-up: The internal oscillator is turned on, causing all internal processing to resume, including the operations of the on-chip peripherals.

If the mouse has moved or if the buttons have been pressed, the application performs a Remote Wake-up sequence, otherwise the application discharges the capacitor and re-enters suspend mode.

Figure 2. shows the RC circuit behaviour when the mouse is not moved.

Figure 2. RC circuit behaviour in suspend mode

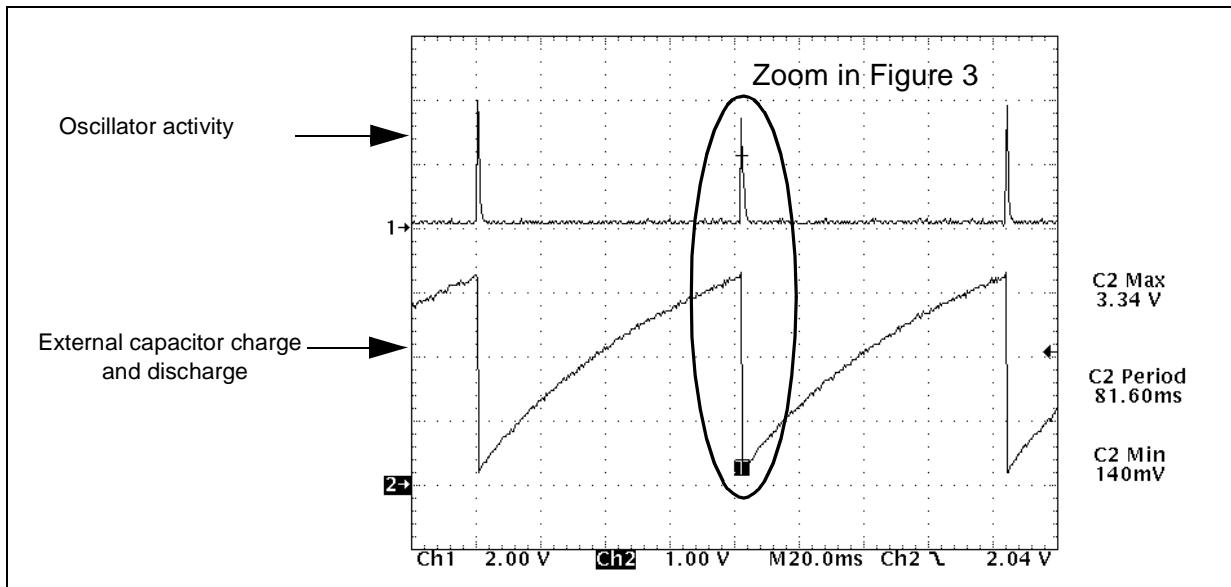

HANDLING SUSPEND MODE ON A USB MOUSE

During the charge of the capacitor, the microcontroller is in low-power mode, it draws only about 250 μA . As soon as the charge of the capacitor reaches the low-to-high interrupt trigger value (about 3.35 V), the microcontroller wakes-up. The oscillator is then turned on and a stabilization time is required before releasing CPU clock cycles. This stabilization time is 4096 CPU clock cycles. During this activity phase, the microcontroller draws about 20 mA. This oscillator wake-up phase is shown in Figure 3.

Figure 3. Oscillator Wake-up sequence

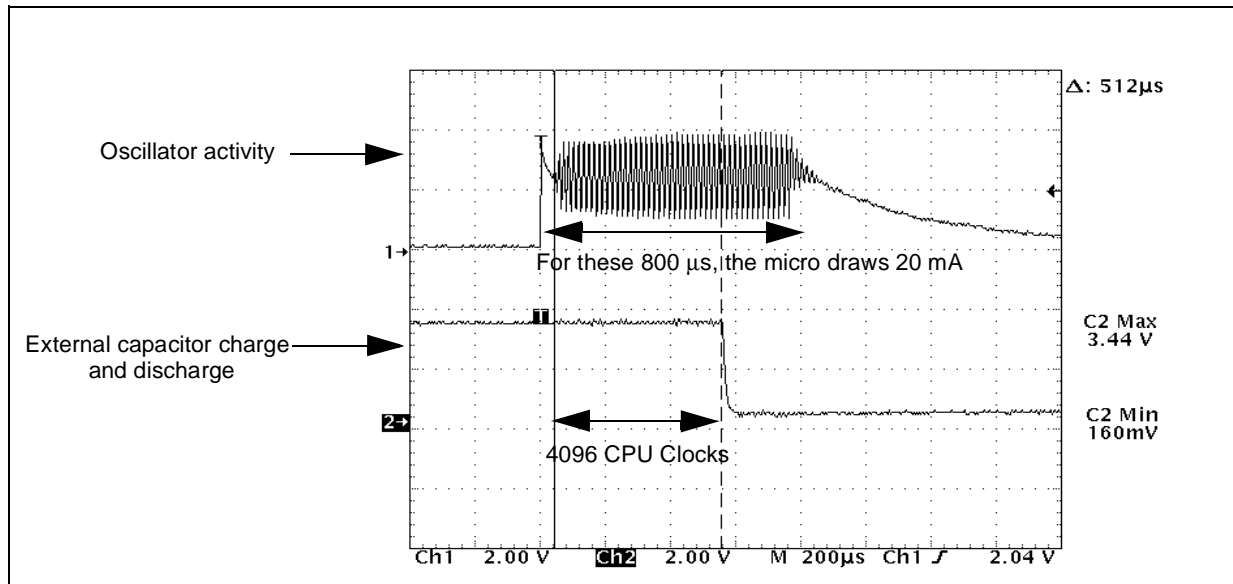

2.4 PHOTO TRANSISTORS TIMING REQUIREMENTS

To check if the mouse has moved, it is necessary to compare the current state of the Photo transistor outputs with the previous ones (recorded before entering suspend mode).

As soon as the microcontroller executes its program code, the infra red LEDs of the mouse are turned on. However, to establish the previous Photo transistor values (especially in case of high level values) a certain amount of time is required. This period is less than 200 μs with the components used . This is due to current establishment in the infra-red diode.

Figure 4. Photo transistor behaviour

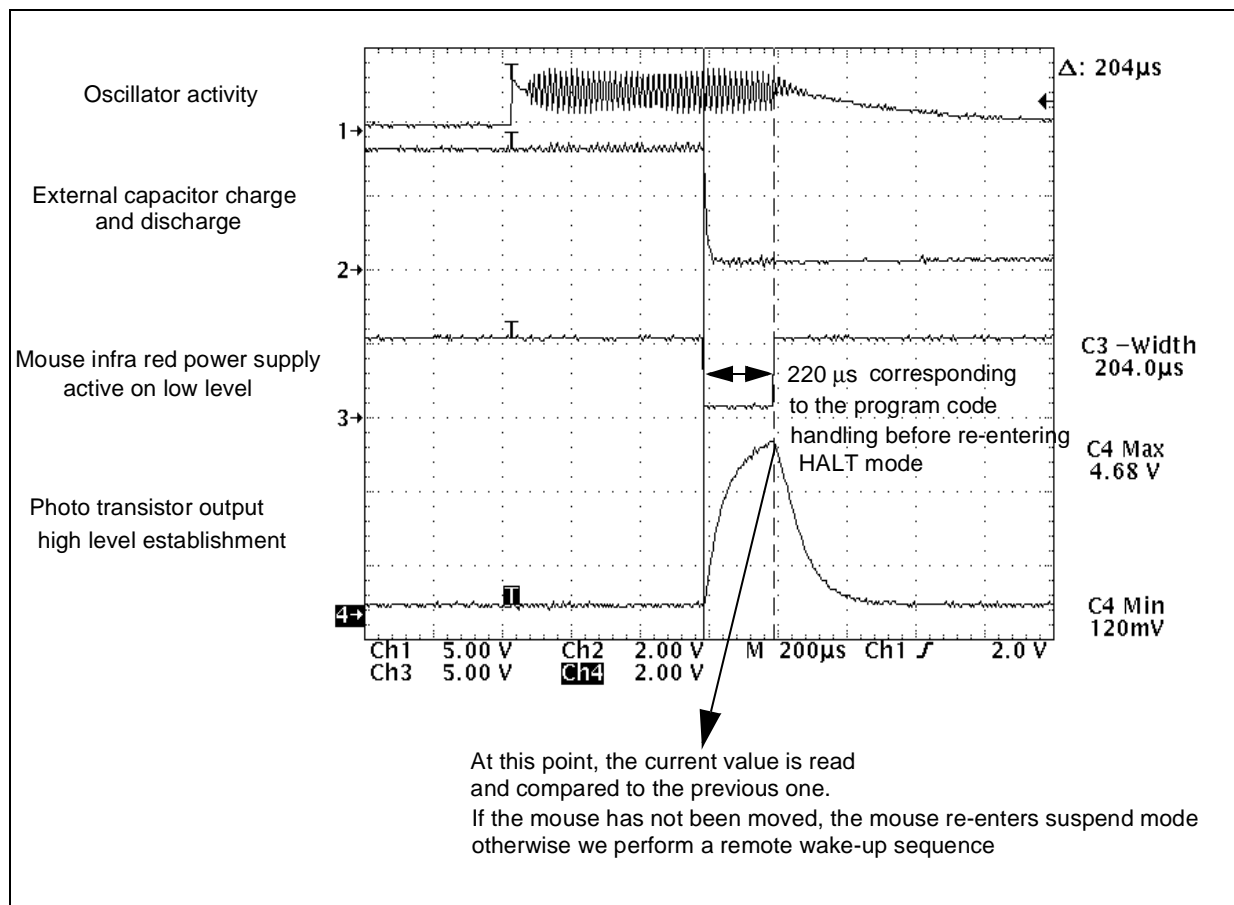

HANDLING SUSPEND MODE ON A USB MOUSE

2.5 RC TIME CONSTANT CALCULATION

As shown on the previous oscillogram, the microcontroller is active for 800 μ s and it draws 20 mA. It is in low-power mode during the rest of the period and draws about 250 μ A.

The following equation enables you to calculate the correct value of the RC time period to be within the Suspend mode 500 μ A average max current specification:

$$Specvalue = \frac{(I_{max} \times WakeupTime) + (I_{min} \times (Period - WakeupTime))}{Period}$$

Example:

If you choose 450 μ A to stay well within the specification and with the following parameters:

$I_{max} = 20 \text{ mA}$ - $WakeupTime = 800 \mu\text{s}$ - $I_{min} = 250 \mu\text{A}$

You obtain the following equation:

$$450\mu\text{s} = \frac{(20\text{mA} \times 800\mu\text{s}) + (250\mu\text{A} \times (Period - 800\mu\text{s}))}{Period}$$

A Period value of 80 ms is obtained.

The RC value can then be calculated to get this period.

You need to pay attention to 2 parameters:

- The high level voltage imposed by the high trigger level (about 3.4V with a +/- 10% variation).
- The input impedance of the pin which modifies the equivalent resistance of the RC circuit.

The following table presents some RC values and the corresponding time periods and consumption measured on a ST7263 microcontroller.

Depending on the application supporting Suspend mode, you will have to find a compromise between the suspend interval time and the suspend average current.

Table 1. RC Value proposal

RC Values	Suspend interval time	Suspend average current
C= 330 nF - R= 1 M Ω	t= 306 ms	I= 400 μ A
C= 330 nF - R= 670 K Ω	t= 200 ms	I= 405 μ A
C= 330 nF - R= 330 K Ω	t= 97 ms	I= 440 μ A
C= 100 nF - R= 670 K Ω	t= 80 ms	I= 450 μ A
C= 100 nF - R= 330 K Ω	t= 37 ms	I= 540 μ A (out of spec.)

Note 1: Suspend mode consumption has been measured with Ports A and C configured as outputs (This has been done to avoid additional current consumption in their pull-up resistors)

HANDLING SUSPEND MODE ON A USB MOUSE

Note 2: A USB Mouse is a Human Interface Device. This means that it is manipulated by an operator at quite a low frequency. For mouse pointing devices, the best compromise is obtained by choosing an RC value which allows you to enter remote wake-up mode and frequently check the device sensor states (10 times per second is enough).

3 RESUME MODE

As soon as a different value has been read from the buttons or photo transistor outputs, the microcontroller performs a Remote Wake-up sequence to resume the communication flow between the Device and the Host.

An example of such a sequence is shown in Figure 5.

Figure 5. Resume state behaviour

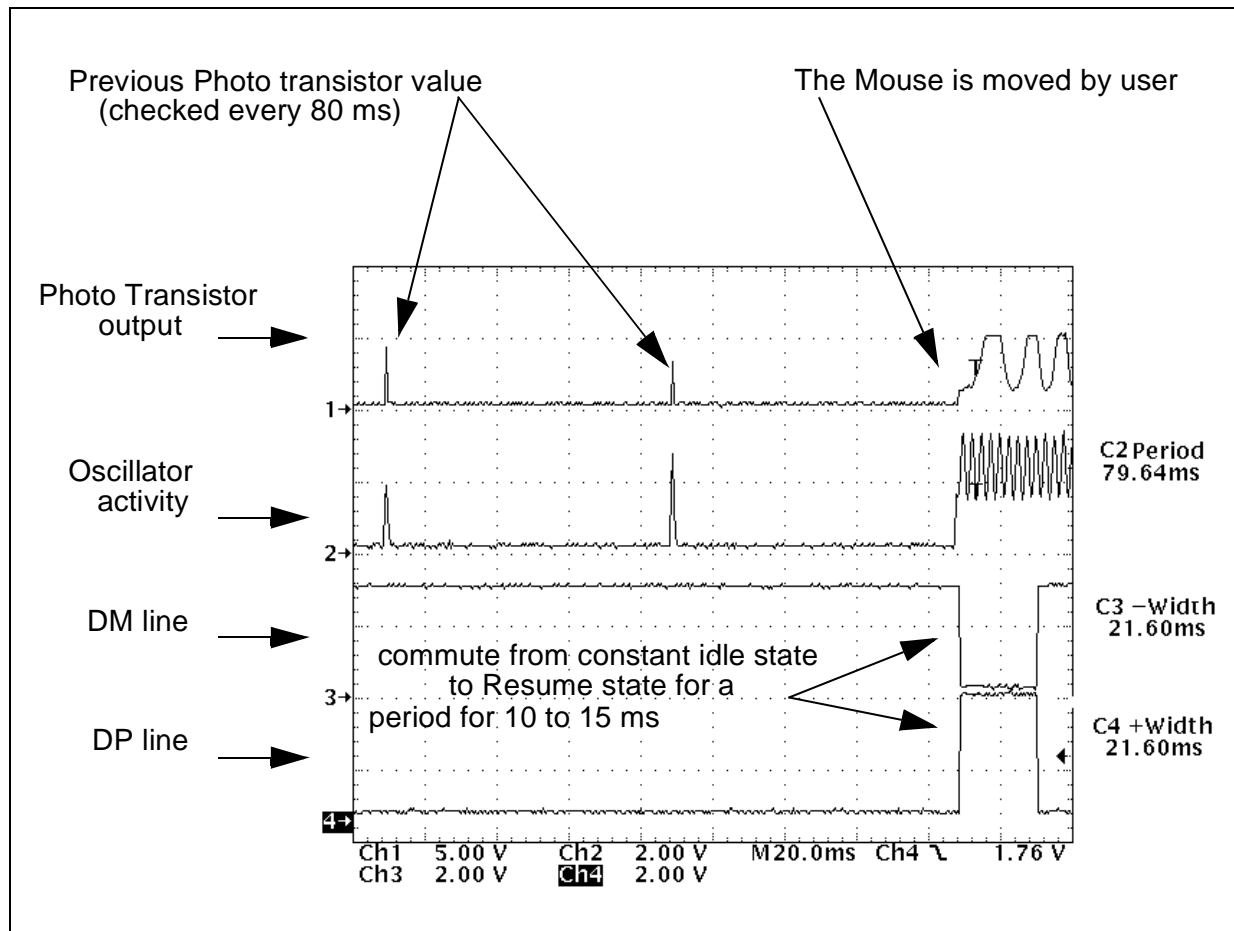

Note that the DM and DP lines are maintained in Resume state for 21.6 ms while the USB specification release 1.1 requires the device to assert Resume signalling for a period between 10 ms and 15 ms. In fact the device asserts Suspend state for only 12 ms and then the host maintain this state for 21.6 ms. This 20 ms minimum Resume signalling time insures that all devices in the network that are enabled to see the resume are woken-up.

4 SOFTWARE IMPLEMENTATION

In the following section, all the programs have been developed using the Hiware C compiler Toolchain. ST provides a complete architecture as well as firmware drivers to help you develop your application quickly and easily. A list of reference documents is provided at the end of the application note.

Depending on the ST7263 microcontroller, all USB events are managed by interrupt. When an USB event occurs, a flag of the Interrupt State Register (ISTR) is set by hardware. Then, the firmware determines the interrupt origin by reading the ISTR register, sets the corresponding bit in a software register (bmUsbIntFlag), and clears the interrupt flag. The USB polling routine reads the software register (bmUsbIntFlag) to determine the USB interrupt source and jumps to the corresponding interrupt routine.

Each interrupt routine sets the global variable “bmUsbState” to the corresponding USB state: SOF, Ennumerated, Suspended or Remote wake-up.

In the *Check_UsbState.c* file you only have to adapt your code to the example given below to handle resume and remote wake-up modes. Don't forget to put all the I/Os in low-power mode in order to draw less than 500µA.

Figure 6. shows the flow-chart of the main application loop.

Figure 6. USB Suspend / Remote wake-up handling

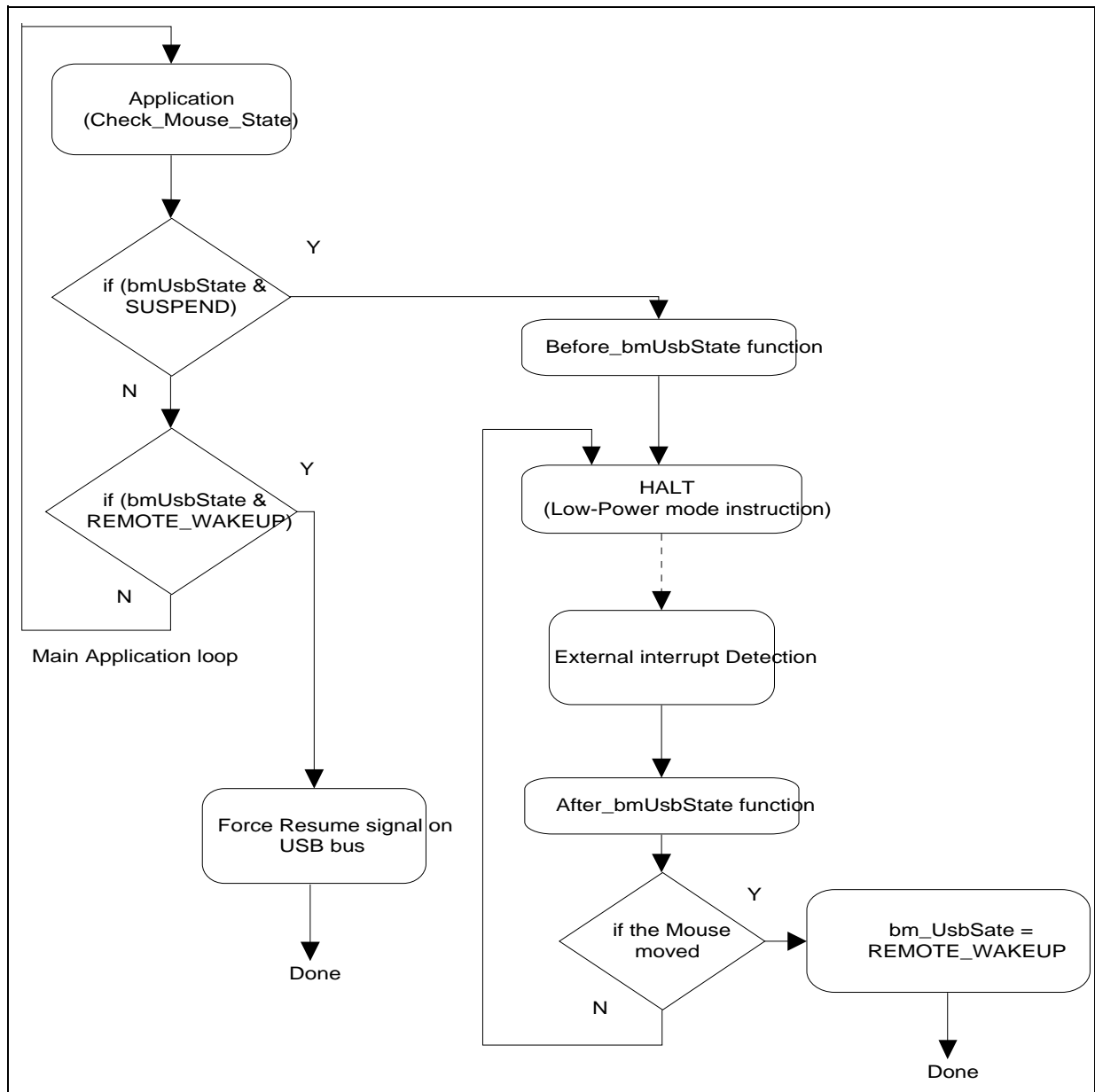

The remote wake-up command is sent from device to Host. This happens when the microcontroller has been suspended and an external interrupt (PB5) restarts the oscillator. To send a remote wake up signal, the `bmUsbState` variable is set in the `Check_UsbState.c` file if the mouse has been moved. Otherwise, we re-enter Suspend mode.

5 PROGRAM FLOW

The following code gives an example of a USB Mouse application for handling suspend and remote wake-up modes.

```

/*-----
ROUTINE NAME : Before_Enter_Suspend
INPUT/OUTPUT :
DESCRIPTION : This function details what we have to do before entering suspend
mode
/*-----
void Before_Enter_Suspend(void)
{
    unsigned int k;           // variable used in the capacitor discharge loop
    PADDR = 0xFF;           // The 2 Ports are configured in output for minimum
                           // current consumption

    PCDDR = 0xFF;
    SetBit(PBDDR,5);        // PB5 in output mode (external RC circuit)
    ClrBit(PBDR,5);         // Clr PB5 : Discharge the external capacitor
    for (k=17; k>0; k--)    // 50us loop: This time interval is mandatory to
        asm nop;           // completely discharge the external capacitor
    Previous_Suspend_State = (PBDR & 0xD8); // Read the Phototransistor value be-
                           // fore entering SUSPEND

    Current_Suspend_State = Previous_Suspend_State;
    SetBit(PCDR,0);         // Switch OFF the Mouse LED
    ClrBit(PBDDR,5);        // PB5 configured in input mode (We let the capacitor
                           // charge)

    Wake_Up_Flag = 0;
    ITRFRE |= 0x20;         // Enable IT6 (PB5)
}
/*-----
ROUTINE NAME : After_End_Suspend
INPUT/OUTPUT :
DESCRIPTION : This function details what we have to do after exiting from suspend
mode
/*-----
void After_End_Suspend(void)
{
    unsigned int j;           // variable used in the 200 us loop
    if (Wake_Up_Flag == 1)
    {
        ClrBit(PCDR,0);      // switch on the Mouse LED
        SetBit(PBDDR,5);     // PB5 in output mode (external RC circuit)
        ClrBit(PBDR,5);      // Clr PB5 : Discharge the external capacitor
        ITRFRE |= 0x20;      // Re enable IT5
        for (j=68; j>0; j--) // 200us loop: This time interval is mandatory to let
    }
}

```

HANDLING SUSPEND MODE ON A USB MOUSE

```
asm nop; } // each Phototransistor reach his previous value
}

/*-----
ROUTINE NAME : Check_BmUsbState
INPUT/OUTPUT :
DESCRIPTION : This subroutine polls the USB global variable bmUsbState
/*-----
void Check_BmUsbState(void)
{
    if(bmUsbState & SUSPEND)
    {
        Before_Enter_Suspend();
        asm
        {
            Loop: halt; // Enters suspend mode
        }

        /***** return from interrupt in SUSPEND Mode *****/

        After_End_Suspend();
        Current_Suspend_State = (PBDR & 0xD8); // Filter on the 4 X-Y axis Optocou-
            pler sensors
        if (Current_Suspend_State == Previous_Suspend_State)
        {
            Current_Suspend_State = Previous_Suspend_State;
            SetBit(PCDR,0); // switch OFF the Mouse Led
            ClrBit(PBDDR,5); // PB5 configured in input (We let the capacitor
                charge)
            ITRFRE |= 0x20; // Re enable IT6
            Wake_Up_Flag = 0;
            asm jp Loop;
        }
        else
        {
            ITRFRE = 0x00; // Disable IT6 (PB5)
            bmUsbState &= ~SUSPEND; // Reset "Go Suspend"
            bmUsbState |= REMOTE_WAKEUP; // Set "Remote Wake-up"
            ClrBit(PBDDR,5); // PB5 configured in input
        }
    }

    if(bmUsbState & REMOTE_WAKEUP)
        RemoteWakeup();
}
```

HANDLING SUSPEND MODE ON A USB MOUSE

```
if (bmUsbState & SOF)
{
    bmUsbState &= ~SOF; // Reset the SOF bit
    Mouse_Counter++; // This variable is used to refresh the Cursor Position
}

if (bmUsbState & SOF)
    nop;
}

/*-----
ROUTINE NAME : INT_IT1IT8
INPUT/OUTPUT : None
DESCRIPTION : Rising edge interrupt
COMMENTS   :
/*-----
#pragma TRAP_PROC SAVE_REGS
void INT_IT1IT8(void)
{
    if (bmUsbState & SUSPEND) // We are in suspend mode
    {
        if ((PBDR & 0x20) == 0x20)
            Wake_Up_Flag = 1;
    }
}
```

REFERENCE DOCUMENTS

- ST7263 Data Sheet
- AN 1017 Using the ST7 Universal Serial Bus Microcontroller
- AN 1069 Developing an ST7 USB Application
- AN 989 Starting with ST7 Hiware C.
- AN 1064 Writing Optimized Hiware C Language for ST7

A general training for ST7 (hardware and development tools) is available on the ST7 CD-ROM.

The USB Descriptor tool DT2.4 is available on the USB website at URL <http://www.usb.org>

HANDLING SUSPEND MODE ON A USB MOUSE

"THE PRESENT NOTE WHICH IS FOR GUIDANCE ONLY AIMS AT PROVIDING CUSTOMERS WITH INFORMATION REGARDING THEIR PRODUCTS IN ORDER FOR THEM TO SAVE TIME. AS A RESULT, STMICROELECTRONICS SHALL NOT BE HELD LIABLE FOR ANY DIRECT, INDIRECT OR CONSEQUENTIAL DAMAGES WITH RESPECT TO ANY CLAIMS ARISING FROM THE CONTENT OF SUCH A NOTE AND/OR THE USE MADE BY CUSTOMERS OF THE INFORMATION CONTAINED HEREIN IN CONNEXION WITH THEIR PRODUCTS."

Information furnished is believed to be accurate and reliable. However, STMicroelectronics assumes no responsibility for the consequences of use of such information nor for any infringement of patents or other rights of third parties which may result from its use. No license is granted by implication or otherwise under any patent or patent rights of STMicroelectronics. Specifications mentioned in this publication are subject to change without notice. This publication supersedes and replaces all information previously supplied. STMicroelectronics products are not authorized for use as critical components in life support devices or systems without the express written approval of STMicroelectronics.

The ST logo is a registered trademark of STMicroelectronics

©1999 STMicroelectronics - All Rights Reserved.

Purchase of I²C Components by STMicroelectronics conveys a license under the Philips I²C Patent. Rights to use these components in an I²C system is granted provided that the system conforms to the I²C Standard Specification as defined by Philips.

STMicroelectronics Group of Companies

Australia - Brazil - China - Finland - France - Germany - Hong Kong - India - Italy - Japan - Malaysia - Malta - Morocco - Singapore - Spain
Sweden - Switzerland - United Kingdom - U.S.A.

<http://www.st.com>