

NOT RECOMMENDED FOR NEW DESIGNS
 Contact Linear Technology for Potential Replacement

FEATURES

- Complete Solution Under 1.2mm
- Develops Three Outputs from a 3.3V or 5V Supply
- Externally Programmable V_{ON} Delay
- Fixed Frequency Low Noise Outputs
- All Ceramic Capacitors
- Operates at 3MHz Switching Frequency
- Fast Transient Response
- Few External Components Required
- 2.6V to 6V Input Range
- Tiny 8-Lead MSOP Package

APPLICATIONS

- TFT-LCD Notebook Display Panels
- TFT-LCD Desktop Monitor Display Panels
- Digital Cameras
- Handheld Computers

DESCRIPTION

The LT[®]1948 is a highly integrated multiple output DC/DC converter designed for use in TFT-LCD panels. The device contains two independent switching regulators: the main regulator has an adjustable output voltage with an internal 1.1A switch that can generate a boosted voltage as high as 30V while the second regulator generates 23V at up to 10mA for positive bias. A simple level-shift charge pump off the main switch node generates the negative bias voltage. An external capacitor sets the delay time from AV_{DD} reaching final value to 23V appearing at the V_{ON} pin. The 3MHz switching frequency allows the use of tiny low profile chip inductors and capacitors throughout, providing a low noise, low cost total solution with all components under 1.25mm in height. The device operates from an input range of 2.6V to 6V and is available in an 8-lead MSOP package.

LT, LTC and LT are registered trademarks of Linear Technology Corporation.

TYPICAL APPLICATION

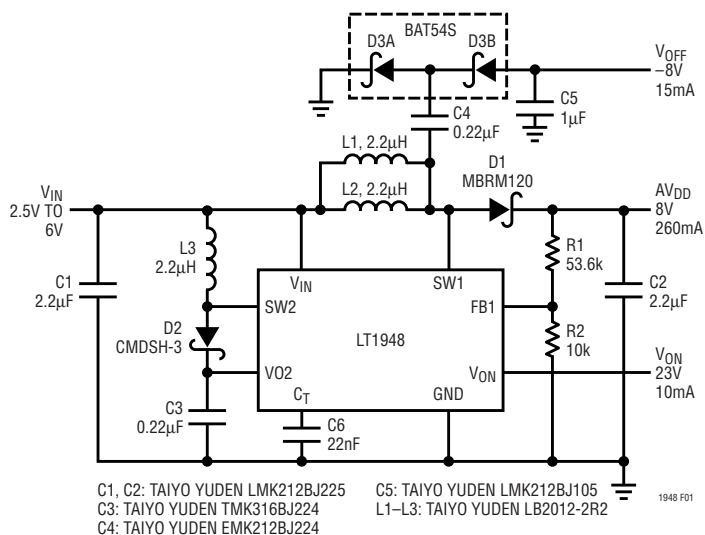
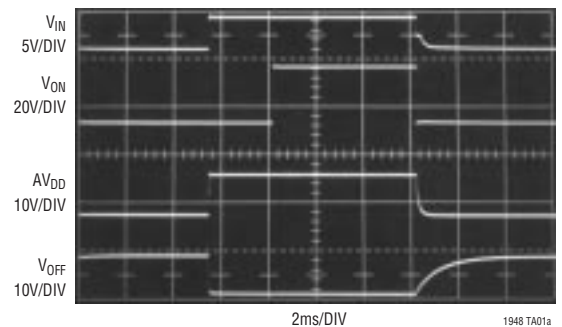

Figure 1. 3.3V Powered TFT-LCD Bias Generator

Start-Up Waveforms



ABSOLUTE MAXIMUM RATINGS

(Note 1)

V_{IN} Voltage	8V
C_T Voltage	6V
SW1, SW2 Voltage	36V
FB Voltage	3V
V_{ON} , VO2 Voltage	30V
Operating Temperature Range (Note 2) ..	-40°C to 85°C
Lead Temperature (Soldering, 10 sec)	300°C

PACKAGE/ORDER INFORMATION

	ORDER PART NUMBER
	LT1948EMS8
	MS8 PART MARKING
	LTNR

Consult factory for Industrial and Military grade parts.

ELECTRICAL CHARACTERISTICS

The ● denotes the specifications which apply over the full operating temperature range, otherwise specifications are at $T_A = 25^\circ\text{C}$. $V_{IN} = 3.3\text{V}$ unless otherwise specified.

SYMBOL	CONDITIONS	MIN	TYP	MAX	UNITS
Supply Current	Not Switching		7	13	mA
Reference Voltage			1.26		V
Reference Line Reg	$2.7\text{V} < V_{IN} < 8\text{V}$		0.01		%/V
C_T Source Current	$V_{FB1} = 1.3\text{V}$	4.5	5.5	6.5	μA
C_T Voltage to Turn On Q3		1.25	1.28	1.30	V
FB1 Voltage to Begin C_T Charge		1.17	1.20	1.23	V
SW1 Current Limit	(Note 3)	1.2	1.5		A
SW2 Current Limit	(Note 3)	0.5	0.8		A
SW1 Saturation Voltage	$I_{SW1} = 800\text{mA}$		350	410	mV
SW2 Saturation Voltage	$I_{SW2} = 300\text{mA}$		250	300	mV
Oscillator Frequency		● 2.4	3.2	3.6	MHz
Maximum Duty Cycle	$0^\circ\text{C} \leq T_A \leq 85^\circ\text{C}$ $-40^\circ\text{C} \leq T_A \leq 0^\circ\text{C}$	● 70 ● 69 ● 67	75	90	% % %
VO2 Pin Resistance	Measured to Ground		400		k Ω
SW1, SW2 Error Amp Gain			100		V/V
SW1, SW2 Error Amp Gm			50		$\mu\text{A}/\text{V}$
FB1 Regulation Voltage		● 1.240 1.230	1.260	1.280 1.285	V V
FB1 Line Regulation	$2.7\text{V} < V_{IN} < 8\text{V}$		0.01	0.05	
VO2 Regulation Voltage		22	23	24	V
V_{ON} Switch Drop	$V_{O2} = 25\text{V}$, 7mA Load from V_{ON} , C_T Voltage $> 1.30\text{V}$		200	260	mV
SW1 Leakage Current	Switch Off, SW1 Voltage = 3.3V		0.01	5	μA
SW2 Leakage Current	Switch Off, SW2 Voltage = 3.3V		0.01	2	μA

Note 1: Absolute Maximum Ratings are those values beyond which the life of a device may be impaired.

Note 2: The LT1948 is guaranteed to meet performance specifications from 0°C to 70°C. Specifications over the -40°C to 85°C operating

temperature range are assured by design, characterization and correlation with statistical process controls.

Note 3: Current limit guaranteed by design and/or correlation to static test.

PIN FUNCTIONS

FB1 (Pin 1): Feedback Pin for First Switcher. Connect resistor divider tap here. Set AV_{DD} according to $AV_{DD} = 1.26V(1 + R1/R2)$.

C_T (Pin 2): Timing Capacitor Pin. Connect a 22nF capacitor from C_T to ground to program a 3ms delay from FB1 reaching 1.26V to V_{ON} turning on.

SW1 (Pin 3): AV_{DD} Switch Node. Connect inductor and D1 here (see Figure 1). Minimize trace area at this pin to keep EMI down.

GND (Pin 4): Ground. Connect directly to local ground plane.

V_{IN} (Pin 5): Input Supply Pin. Must be bypassed with a ceramic capacitor close to the pin.

SW2 (Pin 6): V_{O2} Switch Node. Connect inductor and D2 here. Minimize trace area at this pin to keep EMI down.

V_{O2} (Pin 7): Sense Pin for 23V Output. Connect to V_{O2} output capacitor. This node is also internally connected to the emitter of Q3 (see Block Diagram), the high side switch between V_{O2} and V_{ON} .

V_{ON} (Pin 8): This is the Delayed 23V Output. V_{ON} becomes 23V after the internal timer times out.

OPERATION

To best understand operation of the LT1948, please refer to the LT1948 Block Diagram. The device contains two switching regulators, a timer and a high side switch. Three outputs can be generated: an adjustable AV_{DD} output, a charge-pumped inversion of the AV_{DD} output, called V_{OFF} , and a 23V/15mA output, called V_{ON} . Q3 keeps V_{ON} off for an externally set time interval, set by a capacitor connected to the C_T pin.

The switching frequency of both switchers is 3MHz, set internally. The switchers are current mode and are internally compensated. The main AV_{DD} switcher is current limited at 1.5A, while the second V_{ON} switcher is limited to 800mA. They share the same 1.26V reference voltage.

When the input voltage is below approximately 2.4V, an undervoltage lockout circuit disables switching.

When AV_{DD} is less than its final voltage, Q4 is turned on, holding the C_T pin at ground. When AV_{DD} reaches final value, Q4 lets go of the C_T pin, allowing the 5.5 μ A current source to charge the external capacitor, C_T . When the voltage on the C_T pin reaches 1.25V, Q3 turns on, connecting V_{O2} to V_{ON} . Capacitor value can be calculated using the following formula:

$$C = (5.5\mu A \cdot t_{DELAY})/1.25V$$

A 22nF capacitor results in approximately 3ms of delay.

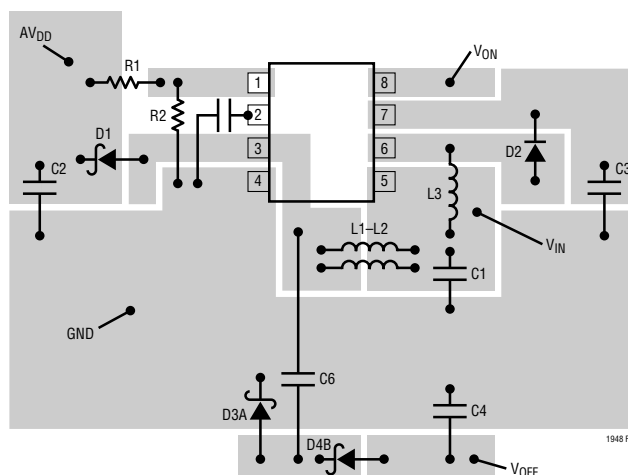
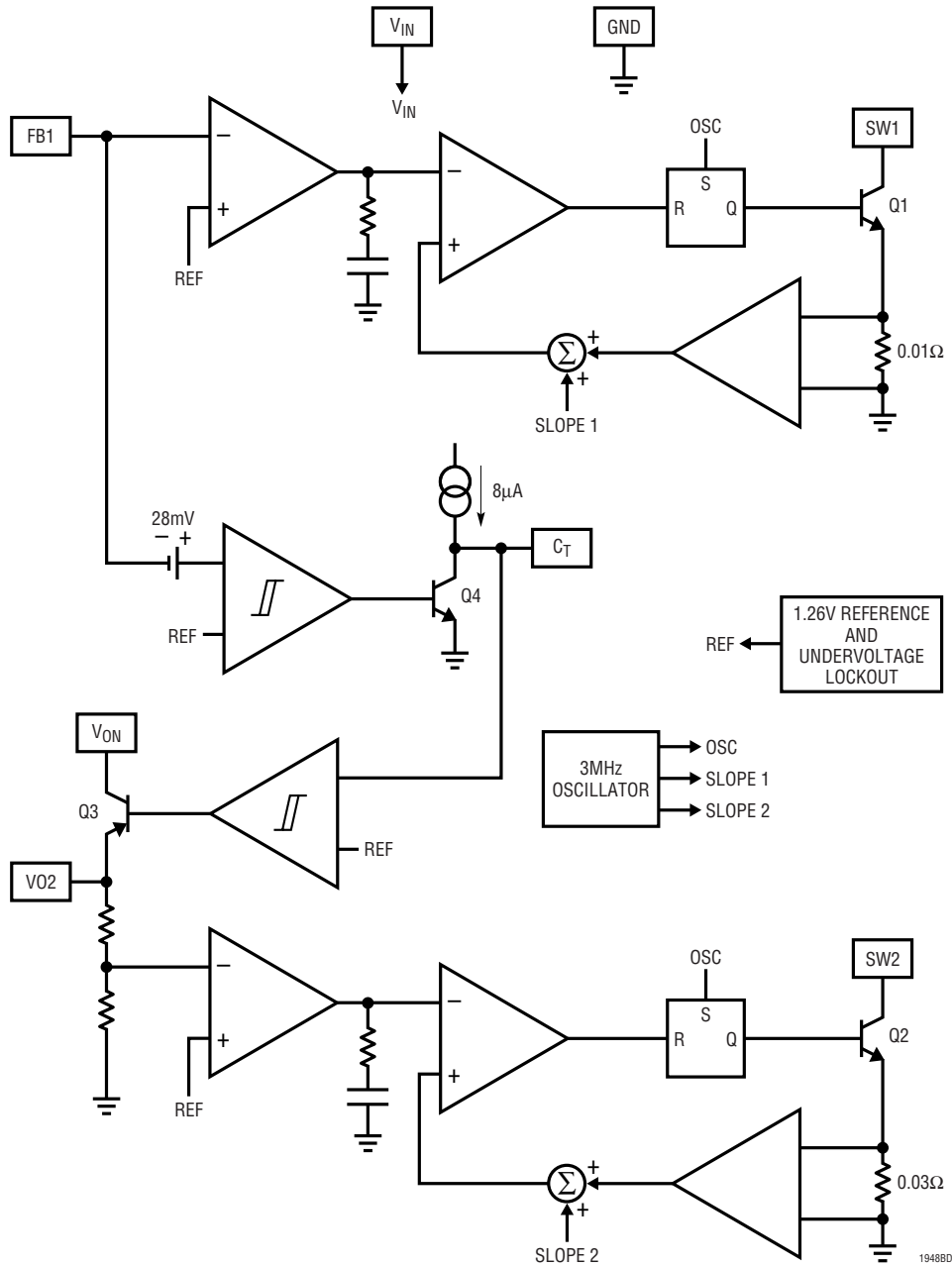

Figure 2. Recommended Component Placement

BLOCK DIAGRAM



RELATED PARTS

PART NUMBER	DESCRIPTION	COMMENTS
LT1949	600kHz, 1A Switch PWM DC/DC Converter	10V at 175mA from 3.3V Input
LT1317	2-Cell Micropower DC/DC with Low-Battery Detect	3.3V at 200mA from 2-Cell Input
LT1308B	600kHz Single Cell Step-Up Regulator	5V at 1A from a 1-Cell Li-Ion Battery
LT1615	Micropower Step-Up Regulator in SOT-23	20V at 12mA from 2.5V Input, 5-Lead SOT-23 Package
LT1930	1.2MHz, Step-Up Regulator in SOT-23	5V at 480mA from 3.3V, 5-Lead SOT-23 Package