

# DATA SHEET

**TDA8303**

**TDA8303A**

Small signal combination IC for  
black/white TV

Preliminary specification  
File under Integrated Circuits, IC02

July 1992

## Small signal combination IC for black/white TV

**TDA8303**  
**TDA8303A**

### FEATURES

- Video IF amplifier with synchronous demodulator
- Automatic gain control (AGC) detector suitable for negative modulation
- AGC tuner
- Automatic frequency control (AFC) circuit with sample-and-hold
- Video preamplifier
- Sound IF amplifier and demodulator
- DC volume control or separate supply for starting the horizontal oscillator
- Audio preamplifier
- Horizontal synchronization circuit with two control loops
- Vertical synchronization (divider system) and sawtooth generation with automatic amplitude adjustment for 50 and 60 Hz
- Transmitter identification (mute)

### GENERAL DESCRIPTION

The TDA8303/TDA8303A combines all small signal functions (except the tuner) which are required for a monochrome television receiver. For a complete black and white receiver only the output stages for video, sound, horizontal and vertical deflection and a tuner have to be added.

The TDA8303 is for applications with npn tuners and the TDA8303A for pnp tuners.

### FUNCTIONAL DESCRIPTION

#### Video IF amplifier, demodulator and video amplifier

Each of the three AC-coupled IF stages permits the omission of DC feedback and possesses a control range in excess of 20 dB. An additional advantage is the symmetry of the amplifier which results in a less critical application.

The IF amplifier is followed by a passive synchronous demodulator providing a regenerated carrier signal. This is limited by a logarithmic limiter circuit prior to its application to the demodulator. The limiter has a very low differential phase shift which results in good differential gain and phase figures.

The video amplifier also contains a white spot inverter and a noise clamp which limits interference pulses to a point below the peak sync level. This circuit is more effective than a noise inverter and results in an improved picture stability, with respect to interference.

#### AFC-circuit

The reference signal for the AFC circuit is obtained from the demodulator tuned circuit. In this way only one tuned circuit needs to be applied and only one adjustment has to be carried out. The disadvantage with this method is that the frequency spectrum of the signal fed to the detector is determined by the SAW filter characteristic. This spectrum is asymmetrical with respect to the picture carrier so that the AFC output voltage is dependent on the video signal.

To overcome this video frequency dependency of the AFC output, the demodulator output is followed by a sample-and-hold circuit which samples during the sync level of the signal. This means that only the carrier signal is available to the AFC and it will not be affected by the video information.

At very weak input signals the drive signal of the AFC circuit will contain substantial noise. This noise has an asymmetrical frequency spectrum causing an offset in the AFC output voltage. This effect can be minimized by applying a notch in the demodulator tuned circuit. The sample-and-hold circuit is followed by an amplifier with high output impedance, therefore the steepness of the of the AFC control voltage is dependent on the load impedance.

### ORDERING INFORMATION

EXTENDED TYPE NUMBER	PACKAGE			
	PINS	PIN POSITION	MATERIAL	CODE
TDA8303	28	DIL	plastic	SOT117 <sup>(1)</sup>
TDA8303A	28	DIL	plastic	SOT117 <sup>(1)</sup>

#### Note

1. SOT117-1; 1996 December 3.

## Small signal combination IC for black/white TV

TDA8303  
TDA8303A

## QUICK REFERENCE DATA

SYMBOL	PARAMETER	CONDITIONS	MIN.	TYP.	MAX.	UNIT
<b>Supply</b>						
$V_P$	positive supply voltage (pin 7)		9.5	12	13.2	V
$I_P$	supply current (pin 7)		90	125	160	mA
$I_{start}$	start current (pin 11)	note 1	–	6.5	9	mA
<b>Video</b>						
$V_{8-9(RMS)}$	IF sensitivity (RMS value)	at 38.9 MHz; note 2	20	40	65	$\mu$ V
$G_{8-9}$	IF gain control range		–	74	–	dB
S/N	signal-to-noise ratio	input signal = 10 mV	–	57	–	dB
$V_{18(p-p)}$	AFC output voltage swing (peak-to-peak value)		10.5	–	11.5	V
<b>Sound</b>						
$V_{12(RMS)}$	AF output signal (RMS value)	note 3	400	600	800	mV
AMS	AM suppression	at $V_I = 50$ mV	–	58	–	dB
THD	total harmonic distortion		–	0.5	–	%
<b>Sync</b>						
$V_{25}$	required sync pulse amplitude	note 4	200	–	–	mV
$I_{27}$	required input current during flyback pulse		0.1	–	2	mA
$V_{22}$	coincidence detector output voltage in synchronized condition		–	9.7	–	V
	in no signal condition		–	1.5	–	V
$V_{22}$	vertical feedback for DC voltage		2.9	3.3	3.7	V
$V_{22(p-p)}$	vertical feedback for AC voltage (peak-to-peak value)		–	1.2	–	V

## Notes to the quick reference data

- Pin 11 has a double function. When during switch-on a current of 9 mA is supplied to this pin, it is used to start the horizontal oscillator. The main supply can then be obtained from the horizontal deflection stage. When no current is supplied to this pin it can be used as a volume control.
- On set AGC.
- The output signal is measured at  $\Delta f = 7.5$  kHz and maximum volume control.
- The minimum value is obtained by connecting a 1.8 k $\Omega$  resistor and a 470 nF capacitor in series between the video output and pin 25. The slicing level can be varied by changing the value of this resistor (higher resistance value results in a larger value of the minimum sync pulse amplitude). The slicing level is independent of the video information.

Small signal combination IC for black/white TV

TDA8303  
TDA8303A

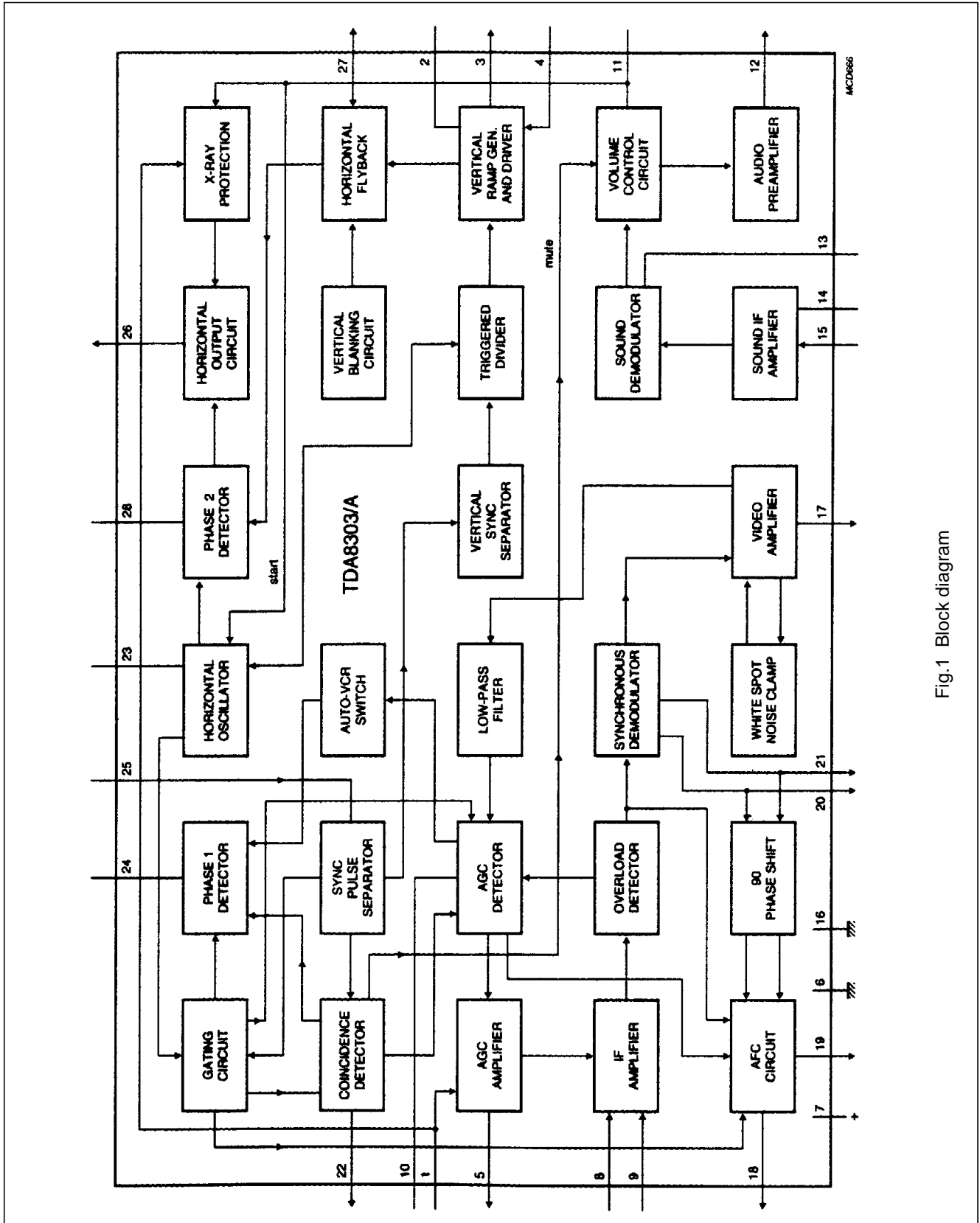

Fig.1 Block diagram

## Small signal combination IC for black/white TV

TDA8303  
TDA8303A

### PINNING

PIN	DESCRIPTION
1	AGC take-over
2	vertical ramp generator
3	vertical drive
4	vertical feedback
5	tuner AGC
6	ground
7	supply voltage input
8	video IF input
9	video IF input
10	IF AGC
11	volume control/start horizontal oscillator
12	audio output
13	sound demodulator
14	sound IF decoupling
15	sound IF input
16	ground (for some critical parts)
17	video amplifier output
18	AFC output
19	AFC S/H, AFC switch
20	video demodulator tuned circuit
21	video demodulator tuned circuit
22	coincidence detector
23	horizontal oscillator
24	phase 1 detector
25	sync separator input
26	horizontal drive output
27	horizontal flyback input
28	phase 2 detector

### AGC circuit

The AGC circuit of the TDA8303/TDA8303A is a top-sync detector. The video signal coming from the video amplifier passes a 2nd order low-pass filter before it is compared with an internal reference level. The comparator stage is gated when the horizontal oscillator is synchronized with the video signal, such that interference pulses outside the gating time have no influence on the gain control.

### Sound circuit

The sound quality of the TDA8303/TDA8303A compared with the predecessors has been improved at weak signal conditions. The improvement has been achieved by the new IF amplifier which is less sensitive for radiation from the sound IF amplifier and by change of the ground and supply connections in the IC. When out-of-sync condition is detected by the coincidence detector the sound output is muted. When no mute is required the minimum voltage level on pin 22 should be clamped to a high level of 5 V. At this level the gating of the AGC is switched off and the phase 1 detector has a high output current for reliable catching of a new transmitter.

### Vertical synchronization

The TDA8303/TDA8303A embodies a synchronized divider system for generating the vertical sawtooth at pin 2 having several advantages and features such as:

- The vertical frequency is alignment free. The divider automatically adapts to a vertical frequency of 50 Hz or 60 Hz including automatic amplitude correction and its operating modes offer maximum interference/disturbance protection.
- A discriminator-window checks the accuracy of the vertical trigger pulse. Internally clock pulses are generated by doubling the line frequency. The divider operates in the 60 Hz mode when the trigger pulse appears before count 576, otherwise the 50 Hz mode will be active.
- The divider system operates with two different reset windows for maximum interference/disturbance protection. The windows are activated via an up/down counter. The counter increases its counter-value by 1 for each time the separated vertical sync pulse appears within the selected window, otherwise the counter value is decreased by 1.

### Modes of operation

Large search window: divider ratio between 488 and 576.

This mode is valid for the following conditions:

- Divider is looking for a new transmitter
- Divider ratio found does not comply with the narrow window specification limits
- Up/down counter value of the divider system, operating in the narrow window mode, drops below count 10

## Small signal combination IC for black/white TV

TDA8303  
TDA8303A

Narrow window mode: divider ratio between 522 and 528 (60 Hz); or 622 and 628 (50 Hz).

- The divider system switches over to narrow window mode when the up/down counter has reached his maximum value of 15 approved vertical sync pulses
- When the divider operates in the narrow window mode and a vertical sync pulse is missing within the window, the divider is reset at the end of that window and the counter value is decreased by 1
- At a counter value below 10 the divider system switches over to the large window mode
- The divider system also generates an anti-top-flutter pulse which inhibits the phase 1 detector during the vertical sync pulse. The pulse width is dependent on the divider mode. For the large window mode the start is generated at the reset of the divider. In the narrow window mode the anti-top-flutter pulse starts at the beginning of the first equalizing pulse. The anti-top-flutter pulse ends at count 10 for the 50 Hz mode and count 12 for the 60 Hz mode

### VCR switch

An extra time constant switch in the horizontal phase detector makes an external VCR switch redundant. The time constant is automatically switched depending on the signal strength of the IF input (pins 8/9) and the coincidence detector.

When a strong signal is detected ( $V_{8/9} > 2.2$  mV) and the circuit is synchronized the time constant of the phase detector is optimum for VCR playback, a fast time constant during the vertical retrace to correct head errors of the VCR and during scan a sufficient time constant to correct fluctuations of the horizontal sync

During weak signal and synchronized conditions the time constant is enlarged and the phase detector is gated. This

ensures a stable display which is not disturbed by the noise in the video signal. When the circuit is not synchronized the time constant is fast and not gated to ensure a short catching time.

### Combination of DC volume control and start-up feature

Pin 11 of the IC can be used as a DC volume control or as a start-up feature of the horizontal oscillator/output circuit dependent on the application.

Volume control is achieved by connecting a 4.7 k $\Omega$  potentiometer or a DC voltage of 0 to 3 V to pin 11. When a current of 9 mA is supplied to pin 11 the volume control is set to a fixed output signal level and the circuit will generate drive pulses for the horizontal deflection and the main supply can be derived from the deflection.

### Application when external video signals require synchronization

The input to the sync separator is externally available via pin 25. For normal application the video output signal at pin 17 is AC-coupled to the sync separator input. It is possible to interrupt this connection and drive the sync separator from other sources.

When external signals are applied to the sync separator the connections between the two parts must be interrupted. This can be achieved by connecting pin 22 to ground, which results in the following conditions:

- AGC detector is not gated
- Mute circuit not active, sound channel remains switched on
- Phase detector 1 has an optimum time constant for external video sources and is not gated

### LIMITING VALUES

In accordance with the Absolute Maximum System (IEC 134)

SYMBOL	PARAMETER	MIN.	MAX.	UNIT
$V_P$	supply voltage (pin 7)	–	13.2	V
$P_{tot}$	total power dissipation	–	2.3	W
$T_{stg}$	storage temperature range	–55	+150	°C
$T_{amb}$	operating ambient temperature range	–25	+65	°C

## Small signal combination IC for black/white TV

TDA8303  
TDA8303A**CHARACTERISTICS** $V_P = 12\text{ V}$ ;  $T_{\text{amb}} = 25\text{ °C}$ ; carrier 38.9 MHz negative modulation, unless otherwise specified

SYMBOL	PARAMETER	CONDITIONS	MIN.	TYP.	MAX.	UNIT
<b>Supply (pin 7)</b>						
$V_P$	supply voltage range		9.5	12	13.2	V
$I_P$	supply current	no input	90	125	160	mA
$I_{11}$	start current (pin 11)	note 1	–	6.5	9	mA
$V_{11}$	start voltage horizontal oscillator		9.5	–	–	V
$V_{11}$	start protection level	$I_{11} = 12\text{ mA}$	–	–	16.5	V
<b>IF Amplifier (pins 8 and 9)</b>						
$V_{8-9(\text{RMS})}$	input sensitivity (RMS value)	at 38.9 MHz; note 2	25	40	65	$\mu\text{V}$
$V_{8-9(\text{RMS})}$	input sensitivity (RMS value)	at 45.75 MHz; notes 2 and 25	25	40	65	$\mu\text{V}$
$R_{8-9}$	differential input resistance	note 3	–	1300	–	$\Omega$
$C_{8-9}$	differential input capacitance	note 3	–	5	–	pF
$G_{8-9}$	gain control range		–	74	–	dB
$\Delta V_{17}$	output signal expansion for 46 dB input signal variation	note 4	–	1	–	dB
$V_{8-9}$	maximum input signal		100	170	–	mV
<b>Video Amplifier (note 5)</b>						
$V_{17}$	zero signal output level	note 6	–	5.4	–	V
$V_{17}$	peak sync level		2.3	2.5	2.7	V
$V_{17}$	video output signal amplitude	note 7	2.3	2.65	3.0	V
$V_{17}$	white spot threshold level		–	5.7	–	V
$V_{17}$	white spot insertion level		–	3.8	–	V
$Z_{17}$	video output impedance		–	25	–	$\Omega$
$I_{17}$	internal bias current of npn emitter follower output transistor		1.4	1.8	–	mA
$I_{\text{source}}$	maximum source current (pin 17)		10	–	–	mA
$B$	bandwidth of demodulated output signal		5	7	–	MHz
$G_{17}$	differential gain	note 8	–	4	8	%
$\varphi$	differential phase	note 8	–	2	5	deg.
NL	video non linearity	note 9	–	2	5	%
	intermodulation	note 10				
	1.1 MHz; blue		50	60	–	dB
	1.1 MHz; yellow		50	60	–	dB
	3.3 MHz; blue		55	65	–	dB
	3.3 MHz; yellow		55	65	–	dB

## Small signal combination IC for black/white TV

TDA8303  
TDA8303A

SYMBOL	PARAMETER	CONDITIONS	MIN.	TYP.	MAX.	UNIT
S/N	signal-to-noise ratio	10 mV input signal	50	57	–	dB
S/N	signal-to-noise ratio	end of gain control range	50	62	–	dB
V <sub>17</sub>	residual carrier signal		–	2	10	mV
V <sub>17</sub>	residual 2nd harmonic of carrier signal		–	2	10	mV
<b>Tuner AGC</b>						
V <sub>8-9(RMS)</sub>	minimum starting point for tuner take-over (RMS value)		–	–	0.2	mV
V <sub>8-9(RMS)</sub>	maximum starting point for tuner take-over (RMS value)		100	150	–	mV
I <sub>5</sub>	maximum tuner AGC output swing	V <sub>5</sub> = 3 V	4	–	–	mA
V <sub>5</sub>	output saturation voltage	I <sub>5</sub> = 2 mA	–	–	300	mV
I <sub>L</sub>	leakage current (pin 5)		–	–	1	μA
ΔV <sub>I</sub>	input signal variation complete tuner control		0.2	2	4	dB
V <sub>1</sub>	minimum voltage tuner take-over		–	–	1	V
<b>AFC circuit</b>						
I <sub>19</sub>	AFC sample-and-hold switch-off current		0.1	–	–	mA
I <sub>O</sub>	output current (pin 19)	V <sub>19</sub> = 0 V	–	0.1	0.3	mA
I <sub>LO</sub>	output leakage current (pin 19)		–	–	2	μA
V <sub>18</sub>	AFC output voltage swing	notes 18 and 19	10.5	–	11.5	V
I <sub>18</sub>	available output current		0.2	–	–	mA
	control slope		–	100	–	mV/kHz
V <sub>O</sub>	output voltage (pin 18)	AFC off	5.5	6	6.5	V
R <sub>O</sub>	AFC output resistance		–	40	–	kΩ
V <sub>18</sub>	output voltage swing	notes 25 and 26	–	11	–	V
	control slope	notes 25 and 26	–	80	–	mV/kHz
V <sub>18</sub>	output voltage shift with respect to V <sub>I</sub> = 10 mV(RMS)	notes 25 and 26	–	–2	–	V



## Small signal combination IC for black/white TV

TDA8303  
TDA8303A

SYMBOL	PARAMETER	CONDITIONS	MIN.	TYP.	MAX.	UNIT
<b>Sound circuit (note 12)</b>						
V <sub>15</sub>	input limiting voltage	V <sub>O(max)</sub> = -3 dB	-	400	800	μV
R <sub>15</sub>	input resistance		-	2.6	-	kΩ
C <sub>15</sub>	input capacitance		-	6	-	pF
AMS	AM suppression	note 13	53	58	-	dB
V <sub>12(RMS)</sub>	AF output signal (RMS value)	note 14	400	600	800	mV
V <sub>12(RMS)</sub>	AF output signal when pin 11 is used as a starting pin or connected to V <sub>P</sub> (RMS value)	Δf = 50 kHz	500	900	1500	mV
Z <sub>12</sub>	AF output impedance		-	25	100	Ω
THD	total harmonic distortion	note 15	-	0.5	2	%
RR	ripple rejection	volume control -20 dB; f <sub>k</sub> = 100 Hz	-	35	-	dB
V <sub>12</sub>	output voltage when muted		-	2.5	-	V
V <sub>12</sub>	output level shift due to muting	volume control -20 dB	-	-	0.5	dB
S/N	signal-to-noise ratio	note 16	-	47	-	dB
V <sub>11</sub>	voltage with pin 11 disconnected		-	6	-	V
I <sub>11</sub>	current with pin 11 short-circuited to ground		-	1	-	mA
V <sub>12</sub>	temperature dependence of the output signal amplitude	T <sub>amb</sub> = 20 to 65 °C; -30 dB volume control and voltage of pin 11 fixed; note 17	-	2.5	-	dB
<b>Volume control (note 17; see Fig.8)</b>						
R <sub>11</sub>	external control resistor	note 17	-	4.7	-	kΩ
OSS	suppression of output signal during mute condition		60	66	-	dB
<b>Horizontal synchronization circuit (see Fig.9)</b>						
SYNC SEPARATOR						
V <sub>25</sub>	required sync pulse amplitude	note 20	200	750	-	mV
I <sub>25</sub>	input current (pin 25)	V <sub>25</sub> > 5 V	-	8	-	μA
		V <sub>25</sub> = 0 V	-	10	-	mA
FIRST CONTROL LOOP						
±Δf	PLL holding range		-	1500	2000	Hz
±Δf	PLL catching range		600	1500	-	Hz
	control sensitivity to oscillator	note 21	see Fig.10			
V <sub>8-9</sub>	IF input signal at which the time constant is switched (RMS value)	strong-to-weak	-	2.2	-	mV

## Small signal combination IC for black/white TV

TDA8303  
TDA8303A

SYMBOL	PARAMETER	CONDITIONS	MIN.	TYP.	MAX.	UNIT
SECOND CONTROL LOOP (POSITIVE EDGE)						
$\frac{\delta t_d}{\delta t_o}$	control sensitivity	note 22	–	100	–	
$t_d$	control range		–	25	–	$\mu\text{s}$
PHASE ADJUSTMENT (VIA SECOND CONTROL LOOP)						
	control sensitivity		–	25	–	$\mu\text{A}/\mu\text{s}$
$\alpha$	maximum allowed phase shift		–	$\pm 2$	–	$\mu\text{s}$
HORIZONTAL OSCILLATOR						
$f_{fr}$	free running frequency	$R = 34.3 \text{ k}\Omega$ ; $C = 2.7 \text{ nF}$	–	15625	–	Hz
$\Delta f$	spread with fixed external components		–	–	4	%
$\Delta f_{fr}$	frequency variations with supply voltage from 9.5 to 13.2 V		–	–	2	%
$\Delta f_T$	frequency variation with temperature	note 25	–	–1.6	–	$\text{Hz}/^\circ\text{C}$
$\Delta f_{fr}$	maximum frequency deviation at start of horizontal output		–	–	10	%
$\Delta f$	frequency variation when only noise is received	note 25	–	–	500	Hz
HORIZONTAL OUTPUT (PIN 26; OPEN COLLECTOR)						
$V_{26}$	output limiting voltage		–	–	16.5	V
$V_{OL}$	LOW level output voltage	$I_{\text{sink}} = 10 \text{ mA}$	–	0.2	0.5	V
$I_{\text{sink}}$	maximum sink current		10	–	–	mA
	duty factor of output signal		–	46	–	%
$t_r$	rise time of output pulse		–	260	–	ns
$t_f$	fall time of output pulse		–	100	–	ns
HORIZONTAL FLYBACK INPUT (PIN 27)						
$I_{27}$	required input current during flyback pulse		0.01	–	1.0	mA
COINCIDENCE DETECTOR						
$V_{22}$	voltage for in-sync condition		–	9.8	–	V
$V_{22}$	voltage for no-sync condition	no signal	–	1.5	–	V
$V_{22}$	switching level to the phase detector from fast to slow		6.2	6.7	7.2	V
$V_{22}$	hysteresis slow to fast		–	0.6	–	V
$V_{22}$	switching level to activate the mute function (transmitter identification)		2.5	2.8	3.1	V
$V_{22}$	hysteresis mute function		–	2	–	V
$t_d$	delay of mute release after transmitter insertion		–	–	300	$\mu\text{s}$
	allowable load on pin 22		–	–	10	$\mu\text{A}$
$V_{22}$	external video mode		–	–	0.7	V
$I_{22}$	current at pin 22	$V_{22} = 0 \text{ V}$	–	–	0.8	mA

## Small signal combination IC for black/white TV

TDA8303  
TDA8303A

SYMBOL	PARAMETER	CONDITIONS	MIN.	TYP.	MAX.	UNIT
<b>Vertical circuit (note 24)</b>						
VERTICAL RAMP GENERATOR						
$I_2$	input current during scan		–	–	2	$\mu\text{A}$
$I_2$	discharge current during retrace		–	0.8	–	mA
$V_{2(p-p)}$	sawtooth amplitude (peak-to-peak value)		–	1.9	–	V
t	interlace timing of the internal pulses		30	32	34	$\mu\text{s}$
VERTICAL OUTPUT						
$I_3$	available output current	$V_3 = 4\text{ V}$	–	–	3	mA
$V_3$	maximum available output voltage	$I_3 = 0.1\text{ mA}$	4.4	5	–	V
VERTICAL FEEDBACK INPUT						
$V_4$	DC input voltage		2.9	3.3	3.7	V
$V_{4(p-p)}$	AC input voltage (peak-to-peak value)		–	1	–	V
$I_4$	input current		–	–	12	$\mu\text{A}$
$\Delta t_p$	internal pre-correction to sawtooth		–	3	–	%
	deviation amplitude	50/60 Hz	–	–	4	%
	temperature dependency of the amplitude	$T_{\text{amb}} = 20\text{ to }65\text{ }^\circ\text{C}$	–	–	2	%

**Notes to the characteristics**

- Pin 11 has a double function. When during switch-on a current of 9 mA is supplied to this pin, it is used to start the horizontal oscillator. The main supply can then be obtained from the horizontal deflection stage. When no current is supplied to this pin it can be used as a volume control.
- On set AGC.
- The input impedance has been chosen such that a SAW filter can be employed.
- Measured with 0 dB = 450  $\mu\text{V}$ .
- Measured at 10 mV RMS top sync input signal.
- Projected zero point; i.e. with switched demodulator.
- White 10% of the top sync amplitude.
- Measured according to the test line illustrated by Fig.2. The differential gain is expressed as a percentage of the difference in peak amplitudes between the largest and smallest value relative to the subcarrier amplitude at blanking level. The differential phase is defined as the difference in degrees between the largest and smallest phase angle. The differential gain and phase are measured with a DSB signal.
- This figure is valid for the complete video signal amplitude (peak white-to-black); see Fig.3. The non-linearity is expressed as a percentage of the maximum deviation of a luminance step from the mean step, with respect to the mean step.
- The test set-up and input conditions are illustrated by Fig.4. The figures are measured at an input signal of 10 mV RMS.
- Measured with a source impedance of 75 $\Omega$ .

$$\text{The signal-to-noise ratio} = 20 \log \frac{V_O \text{ black-to-white}}{V_{n(RMS)}} \text{ at } B = 5 \text{ MHz}$$

- The sound circuit is measured (unless otherwise specified) with an input signal of  $V_{15}$  of 50 mV RMS, a carrier frequency of 5.5 MHz at a  $\Delta f$  of 27.5 kHz. The QL of the demodulator tuned circuit is 16 and the volume control is

---

**Small signal combination IC for black/white TV**

---

**TDA8303  
TDA8303A**

connected to the supply. The reference circuit must be tuned in such a way that the output is symmetrical clipping at maximum volume.

13. The test set-up is illustrated by Fig.6. The AM rejection curve (typical) is illustrated by Fig.7.
14. The output signal is measured at a  $\Delta f = 7.5$  kHz and maximum volume control.
15. The demodulator tuned circuit must be tuned at minimum distortion.
16. Weighted noise, measured in accordance with CCIR 468.
17. See also note 1. The volume can be controlled by using a potentiometer connected to ground (value 4.7 k $\Omega$ ) or by means of a variable direct voltage. In the latter event the relatively low input impedance must be taken into account.
18. The AFC control voltage is obtained by multiplying the IF output signal (which is also used to drive the synchronous demodulator) with a reference carrier. This reference carrier is obtained from the demodulator tuned circuit via a 90 degree phase shift network. The IF output signal has an asymmetrical frequency spectrum with respect to the carrier frequency. To avoid problems due to this asymmetrical signal the AFC circuit is followed by a sample-and-hold circuit which samples during the sync level. As a result the AFC output voltage contains no video information. The specified control slope decreases when the AFC output is loaded with two resistors between the voltage supply and ground.
19. At very weak input signals the drive signal for the AFC circuit will have a high noise content. This noise input has an asymmetrical frequency spectrum which will cause an offset of the AFC output voltage. The characteristics given for weak signals are measured with a SAW filter (OFW 1956) connected in front of the IC input signal such that the input signal of the IC is 150  $\mu$ V RMS.
20. The minimum value is obtained by connecting a 1.8 k $\Omega$  resistor between pins 17 and 25. The slicing level can be varied by changing the value of this resistor (higher resistor value results in larger value of the minimum sync pulse amplitude). The slicing level is independent of the video information.
21. Frequency control is obtained by supplying a correction current to the oscillator RC network via a resistor connected between the phase 1 detector output and the oscillator network. The oscillator can be adjusted to the correct frequency by short circuiting the sync separator bias network (pin 25) to the voltage supply. To avoid the need of a VCR switch the time constant of the phase detector at strong input signals is sufficiently short to obtain a stable picture during VCR playback. During the vertical retrace period the time constant is even shorter so that the head-errors of the VCR are compensated at the beginning of scan. During conditions of weak signal (information derived from the AGC circuit) the time constant is increased to obtain a better noise immunity.
22. This figure is valid for an external load impedance of 82 k $\Omega$  between pin 28 and the phase adjustment potentiometer.
23. The functions in-sync/out-of-sync and transmitter identification have been combined on pin 22. The capacitor is charged during the sync pulse and discharged during the time difference between gating (6.5  $\mu$ s) and the sync pulse.
24. The vertical scan is synchronized by means of a divider system. Therefore no frequency adjustment is required for the ramp generator. The divider detects whether the incoming signal has a vertical frequency of 50 or 60 Hz and corrects the vertical amplitude.
25. These figures are based on test samples.
26. Measured at an input signal amplitude of 150  $\mu$ V RMS (pin 18).

Small signal combination IC for black/white TV

TDA8303  
TDA8303A

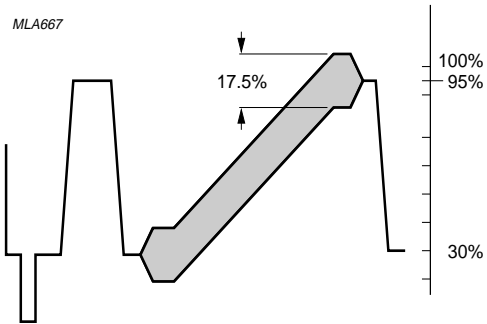

Fig.2 Video output signal.

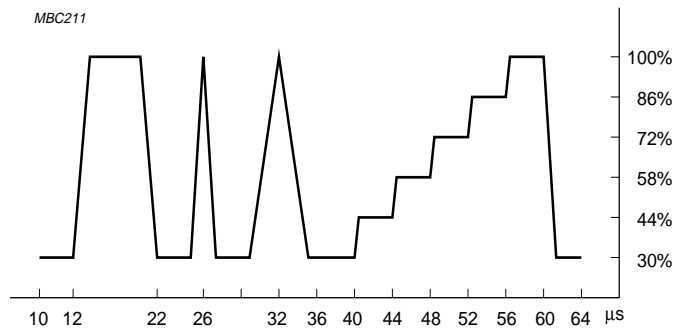
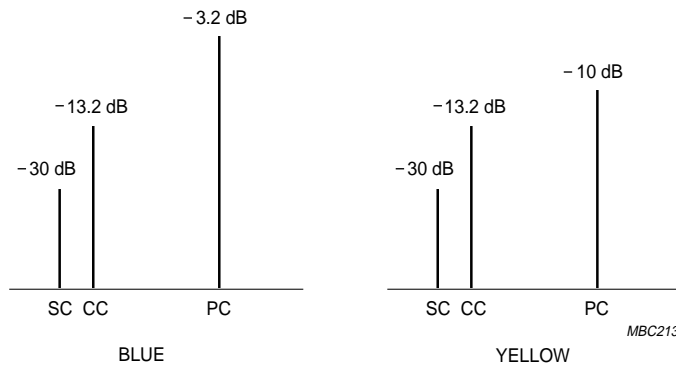
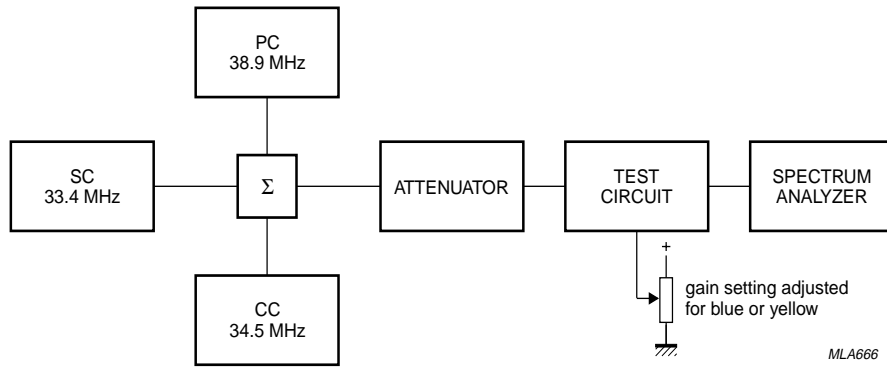

Fig.3 EBU test signal waveform (line 330).

Small signal combination IC for black/white TV

TDA8303  
TDA8303A



Input signal conditions

SC = Sound carrier

CC = Chrominance carrier

PC = Picture carrier

All with respect to top sync level

$$\text{Value at 1.1 MHz} : 20 \log \frac{V_O \text{ at 4.4 MHz}}{V_O \text{ at 1.1 MHz}} + 3.6 \text{ dB}$$

$$\text{Value at 3.3 MHz} : 20 \log \frac{V_O \text{ at 4.4 MHz}}{V_O \text{ at 3.3 MHz}}$$

Fig.4 Test set-up intermodulation.

Small signal combination IC for black/white TV

TDA8303  
TDA8303A

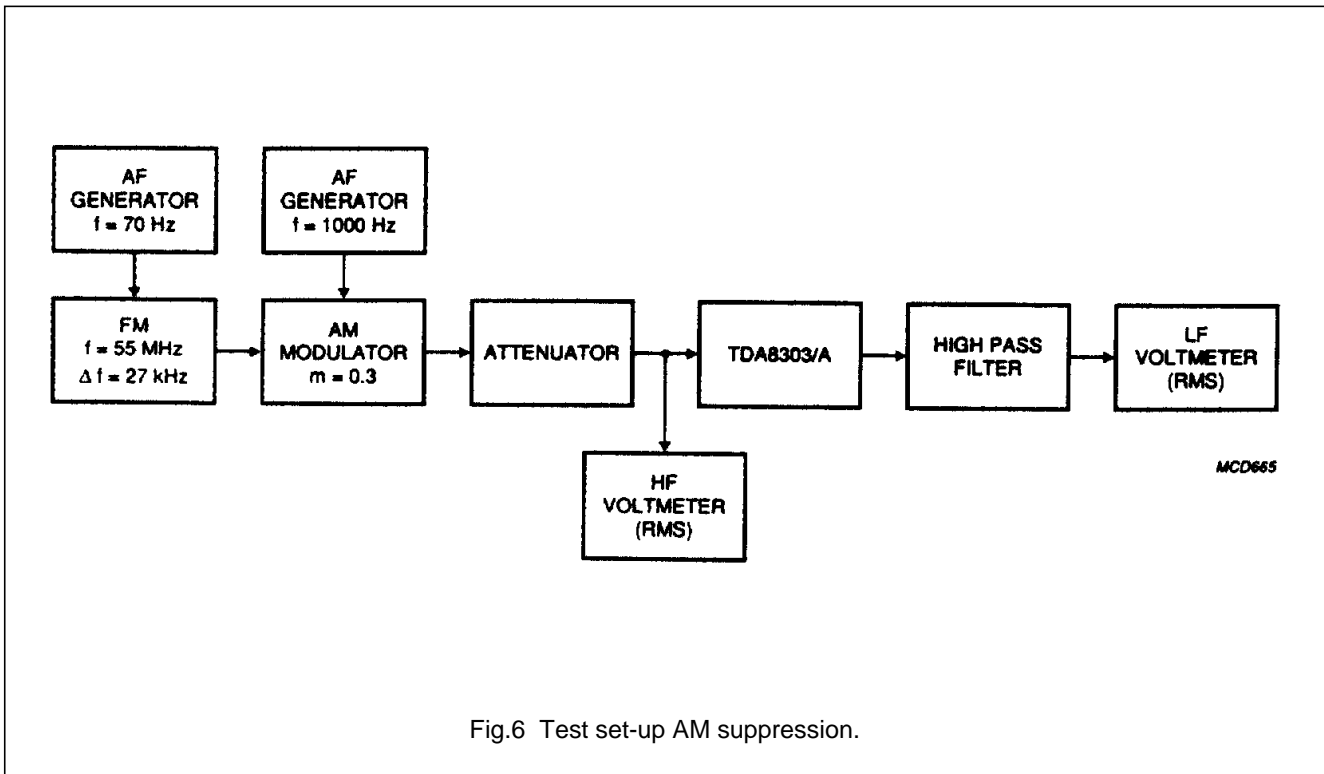
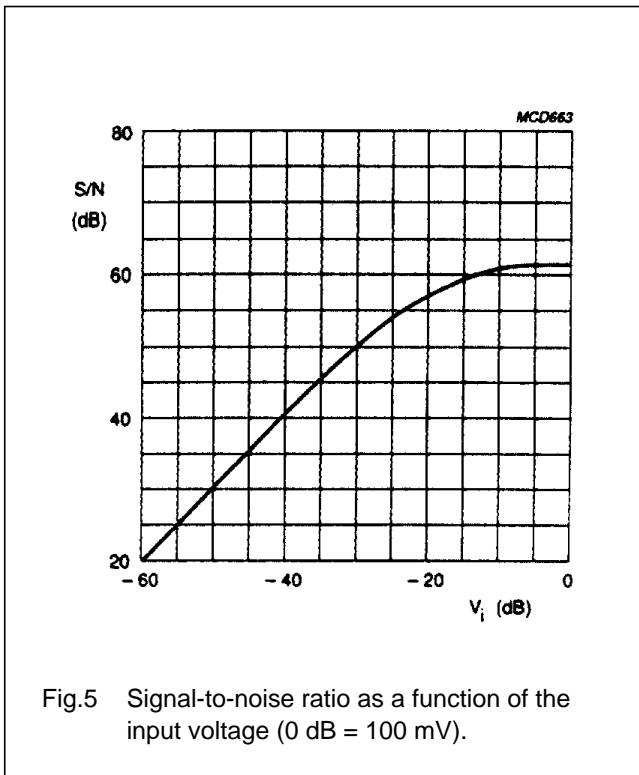

Small signal combination IC for black/white TV

TDA8303  
TDA8303A

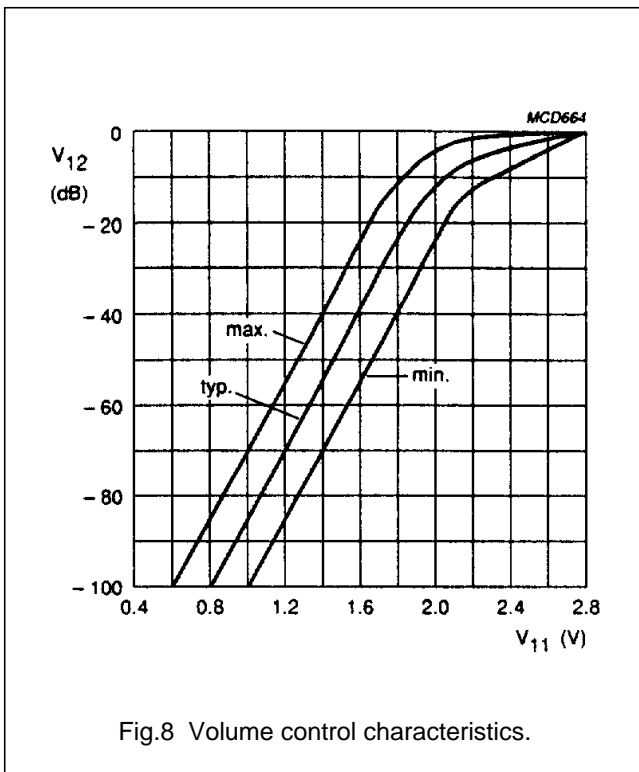
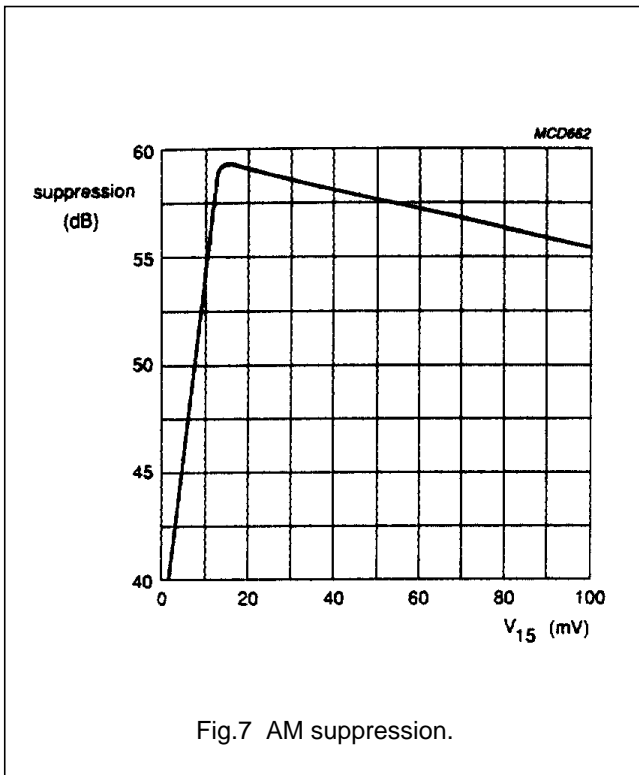



Small signal combination IC for black/white TV

TDA8303  
TDA8303A

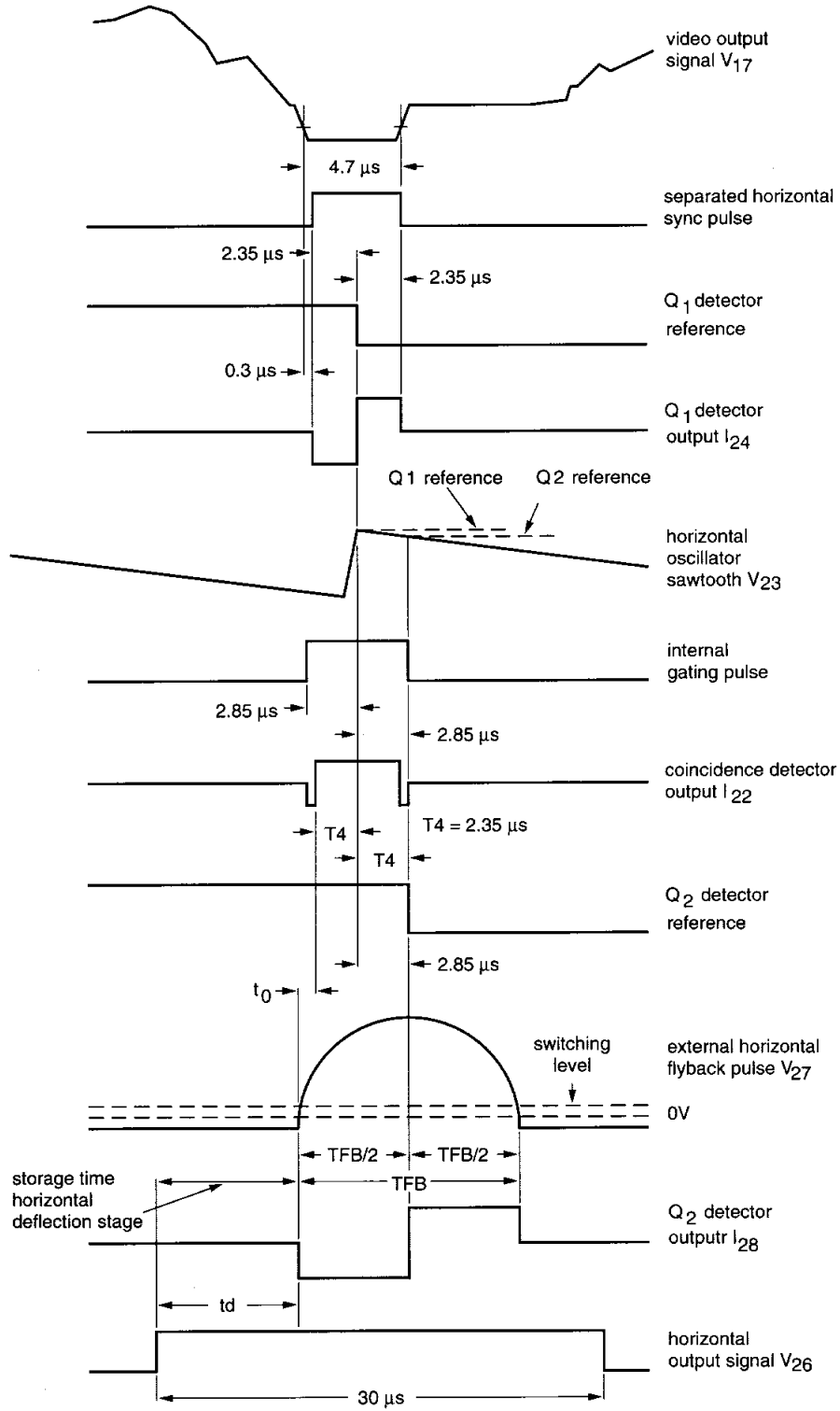

MLA668 - 1

Fig.9 Timing diagram.

Small signal combination IC for black/white TV

TDA8303  
TDA8303A

**Table 1** Switching levels coincidence detector

CONDITION $V_{22}$	CONTROL SENSITIVITY HORIZONTAL OSCILLATOR (kHz/ $\mu$ S)	
	T2 - T1	T3 = SCAN
$V_{22} > 6.7$ V and strong signal	11.3	7.6
weak signal	1.3	1.3
$1 < V_{22} < 5.7$ V and strong signal	11.3	7.6
weak signal	11.3	7.6
$V_{22} < 0.7$	11.3	7.6

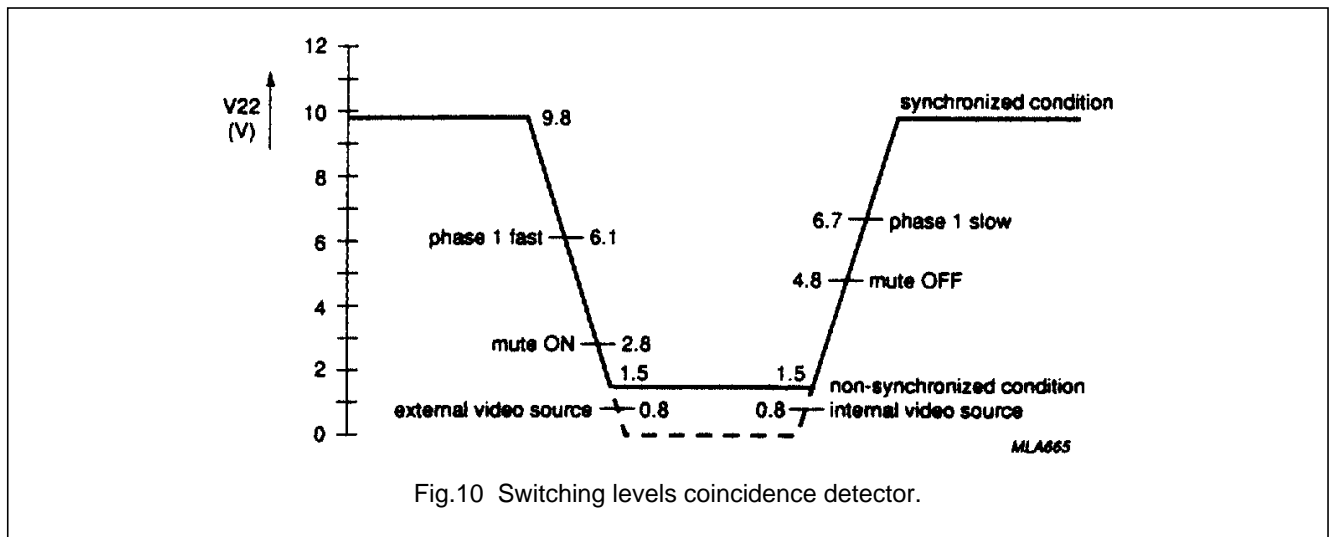

Fig.10 Switching levels coincidence detector.

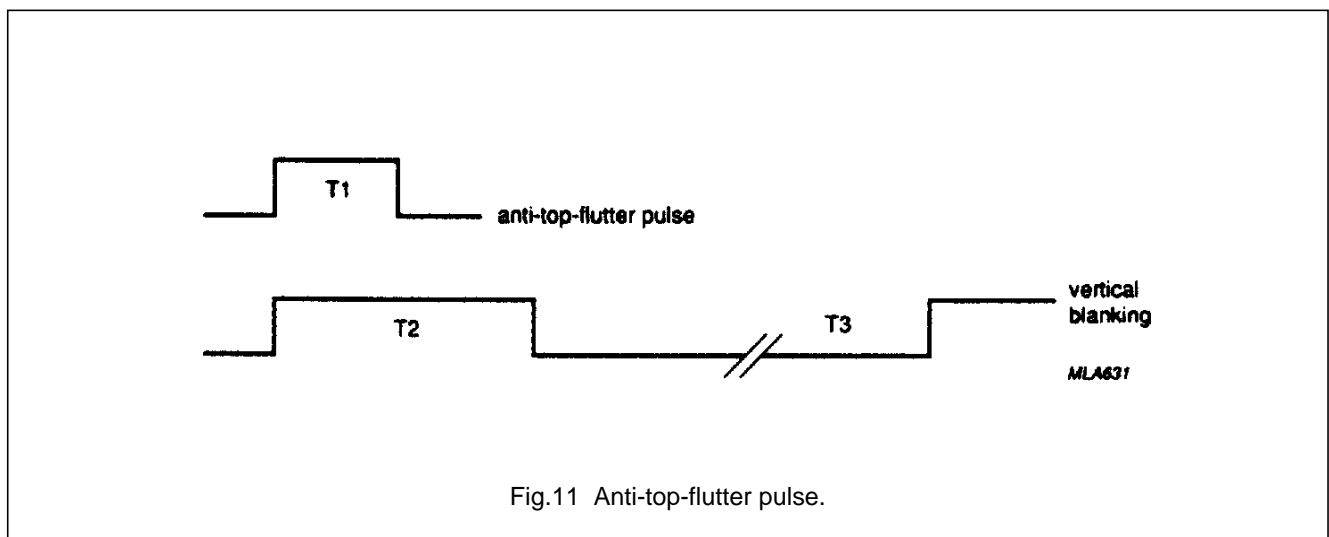

Fig.11 Anti-top-flutter pulse.

Small signal combination IC for black/white TV

TDA8303  
TDA8303A

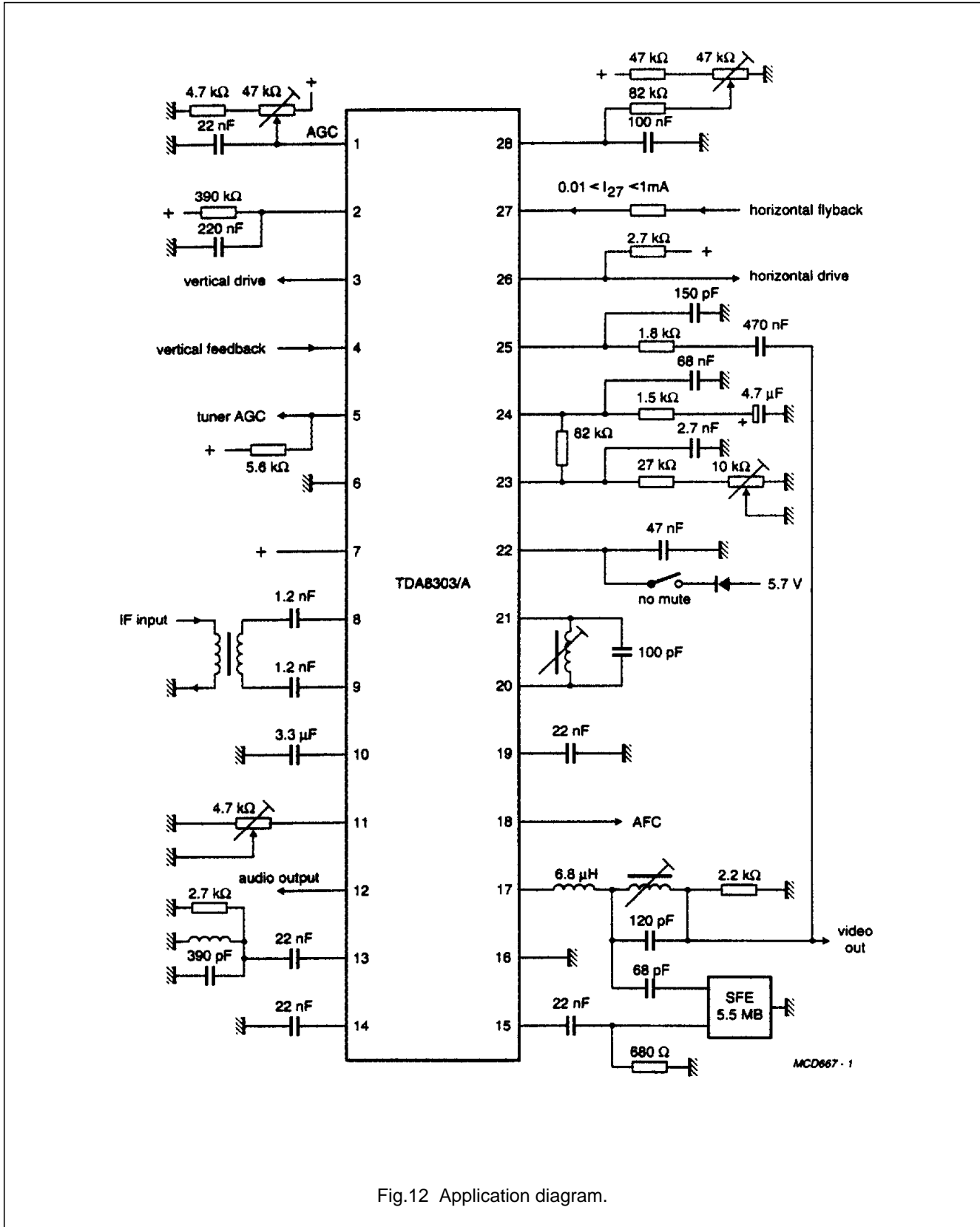

Fig.12 Application diagram.

Small signal combination IC for black/white TV

TDA8303  
TDA8303A

PACKAGE OUTLINE

DIP28: plastic dual in-line package; 28 leads (600 mil)

SOT117-1

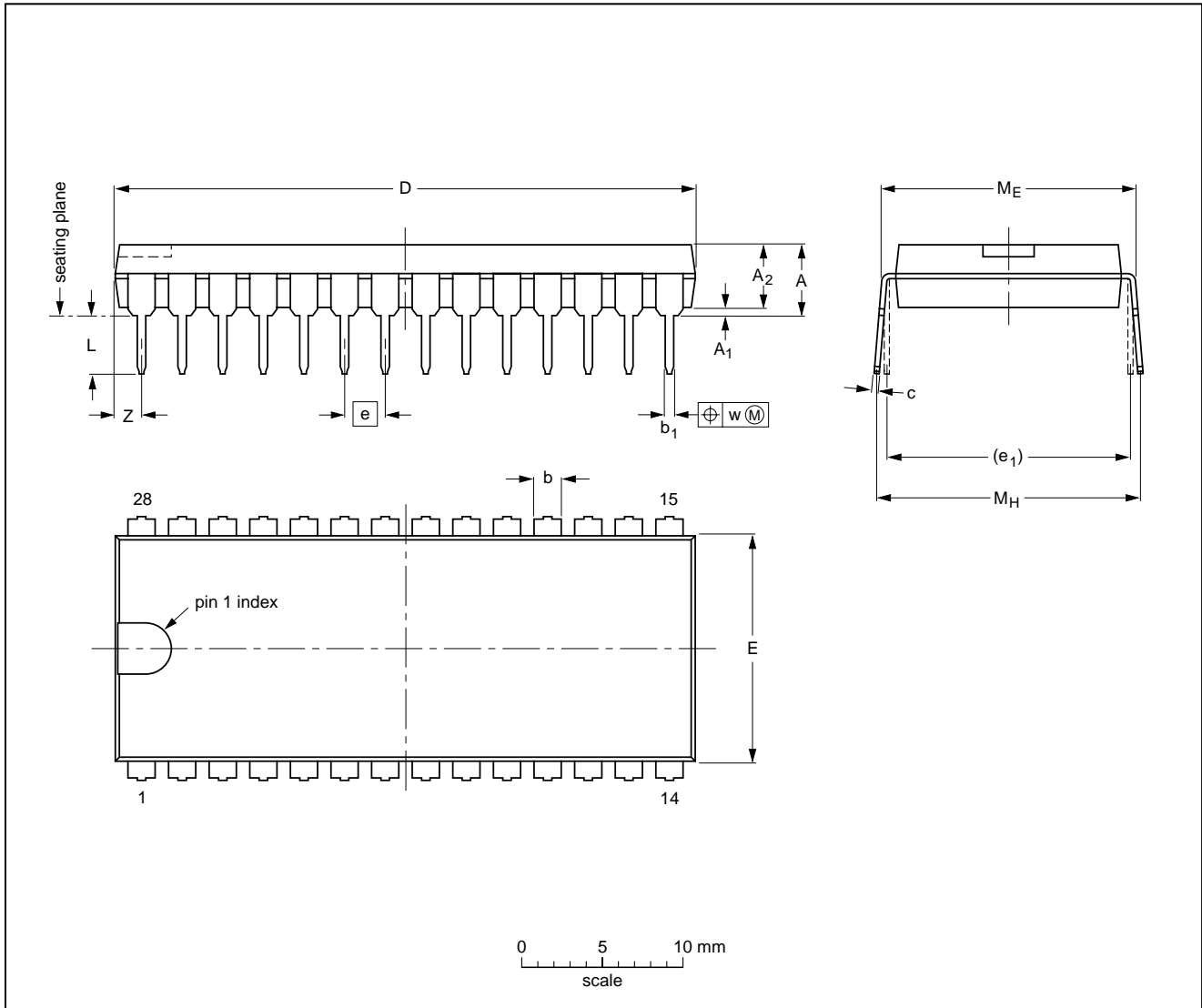

DIMENSIONS (inch dimensions are derived from the original mm dimensions)

UNIT	A max.	A <sub>1</sub> min.	A <sub>2</sub> max.	b	b <sub>1</sub>	c	D <sup>(1)</sup>	E <sup>(1)</sup>	e	e <sub>1</sub>	L	M <sub>E</sub>	M <sub>H</sub>	w	Z <sup>(1)</sup> max.
mm	5.1	0.51	4.0	1.7 1.3	0.53 0.38	0.32 0.23	36.0 35.0	14.1 13.7	2.54	15.24	3.9 3.4	15.80 15.24	17.15 15.90	0.25	1.7
inches	0.20	0.020	0.16	0.066 0.051	0.020 0.014	0.013 0.009	1.41 1.34	0.56 0.54	0.10	0.60	0.15 0.13	0.62 0.60	0.68 0.63	0.01	0.067

Note

1. Plastic or metal protrusions of 0.25 mm maximum per side are not included.

OUTLINE VERSION	REFERENCES				EUROPEAN PROJECTION	ISSUE DATE
	IEC	JEDEC	EIAJ			
SOT117-1	051G05	MO-015AH				92-11-17 95-01-14

## Small signal combination IC for black/white TV

TDA8303  
TDA8303A

### SOLDERING

#### Introduction

There is no soldering method that is ideal for all IC packages. Wave soldering is often preferred when through-hole and surface mounted components are mixed on one printed-circuit board. However, wave soldering is not always suitable for surface mounted ICs, or for printed-circuits with high population densities. In these situations reflow soldering is often used.

This text gives a very brief insight to a complex technology. A more in-depth account of soldering ICs can be found in our "IC Package Databook" (order code 9398 652 90011).

#### Soldering by dipping or by wave

The maximum permissible temperature of the solder is 260 °C; solder at this temperature must not be in contact with the joint for more than 5 seconds. The total contact time of successive solder waves must not exceed 5 seconds.

The device may be mounted up to the seating plane, but the temperature of the plastic body must not exceed the specified maximum storage temperature ( $T_{stg\ max}$ ). If the printed-circuit board has been pre-heated, forced cooling may be necessary immediately after soldering to keep the temperature within the permissible limit.

#### Repairing soldered joints

Apply a low voltage soldering iron (less than 24 V) to the lead(s) of the package, below the seating plane or not more than 2 mm above it. If the temperature of the soldering iron bit is less than 300 °C it may remain in contact for up to 10 seconds. If the bit temperature is between 300 and 400 °C, contact may be up to 5 seconds.

### DEFINITIONS

Data sheet status	
Objective specification	This data sheet contains target or goal specifications for product development.
Preliminary specification	This data sheet contains preliminary data; supplementary data may be published later.
Product specification	This data sheet contains final product specifications.
Limiting values	
Limiting values given are in accordance with the Absolute Maximum Rating System (IEC 134). Stress above one or more of the limiting values may cause permanent damage to the device. These are stress ratings only and operation of the device at these or at any other conditions above those given in the Characteristics sections of the specification is not implied. Exposure to limiting values for extended periods may affect device reliability.	
Application information	
Where application information is given, it is advisory and does not form part of the specification.	

### LIFE SUPPORT APPLICATIONS

These products are not designed for use in life support appliances, devices, or systems where malfunction of these products can reasonably be expected to result in personal injury. Philips customers using or selling these products for use in such applications do so at their own risk and agree to fully indemnify Philips for any damages resulting from such improper use or sale.