

MSE570 Bipolar Stepper Motor Drive Board Data Sheet



Specifications

Bipolar stepper motor drive with optional thermal protection and on board oscillator.

Electrical

Motor supply:

+15 to +36Vdc (+10% max.) smoothed unregulated.

Logic supply:

+15 to +24Vdc (+10% max.) smoothed unregulated.

Note: the motor and logic may share the same power supply up to +24V or up to +36V if a suitable dropper resistor is fitted in the logic supply line.

Auxiliary outputs (available for external circuitry):

+12V regulated 50mA maximum

+5V regulated 50mA maximum

Motor drive output:

Bipolar chopped constant current with overload protection. Suitable for driving hybrid or permanent magnet stepper motors with 4,6 or 8 leads.

Maximum output current 3.5A per phase.

Output current set by on-board DIP switches or external programming resistor.

Control inputs:

CMOS schmitt trigger inputs operating at +12V with 10K Ω pull-up resistors and diode isolation.

Logic 0 (low) - 0V to +2V or contact closure to 0V.

Logic 1 (high) - +9V to +30V maximum or open circuit.

Monitor outputs:

Open collector NPN transistor, referenced to 0V.

Low level - +1V maximum at 30mA maximum.

High level - open circuit +24V dc maximum.

Mechanical and physical

Card size:

Eurocard format 160 mm long x 100 mm wide x 62 mm high.

Weight:

700g approximately.

Connector:

32 way a & c DIN41612 type D.

Operating temperature range:

0°C to 40°C maximum ambient.

External connections

External connections are made via a 32 way a & c DIN41612 type D connector.

The MSE562 is a suitable power supply unit to power up to two MSE570 drives.

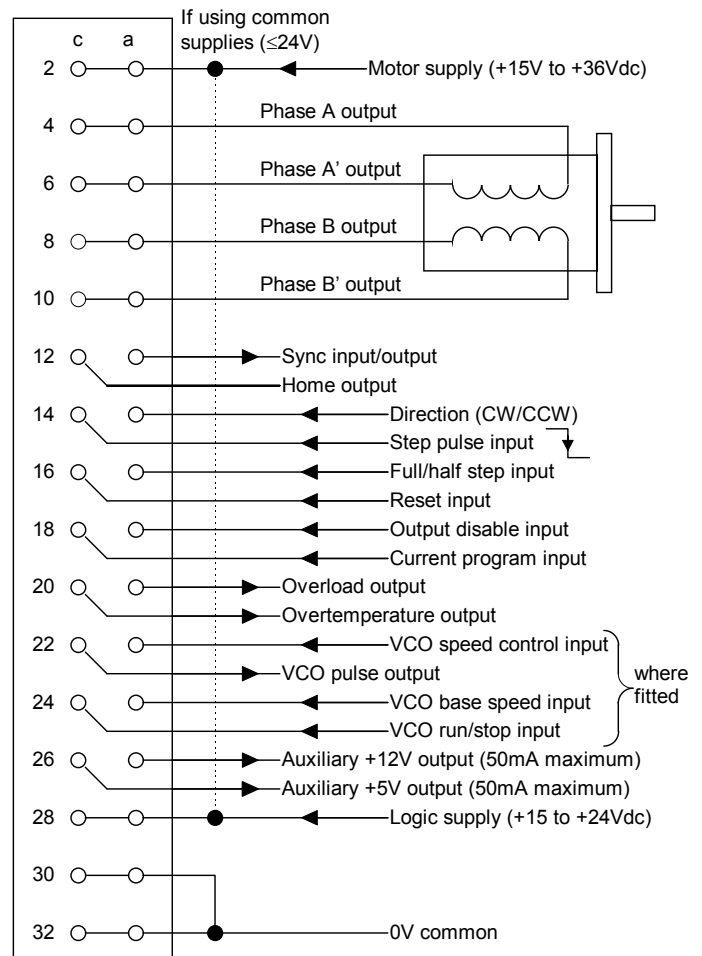

Supplies

Pins 2 a & c

Motor supply input. Should be smoothed unregulated between +15V and +36V maximum.

Pins 28 a & c

Logic supply input. Should be smoothed unregulated between +15V and +24V maximum.

Pins 30 a & c, 32 a & c

0V common.

Motor

Pins 4 a & c, 6 a & c

Motor phase A should be connected between 4 a & c and 6 a & c.

Pins 8 a & c, 10 a & c

Motor phase B should be connected between 8 a & c and 10 a & c.

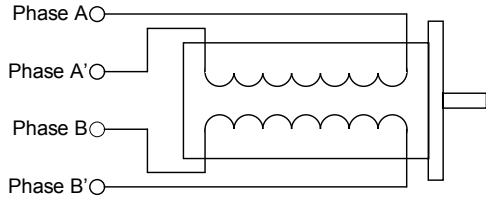

4 lead motor

max drive current = motor phase current rating

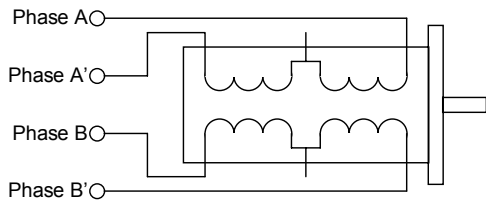

6 lead motor - both coils

max drive current = motor phase current rating / $\sqrt{2}$

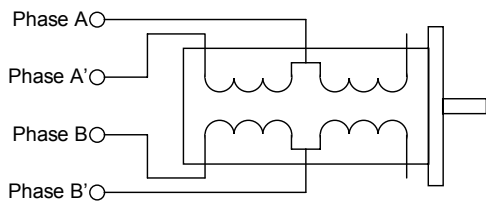

6 lead motor - one coil

max drive current = motor phase current rating

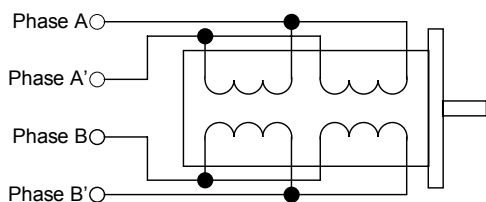

8 lead motor - coils in parallel

max drive current = motor phase current rating x $\sqrt{2}$

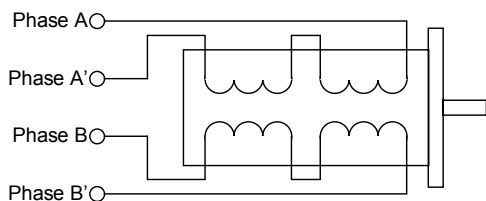

8 lead motor - coils in series.

max drive current = motor phase current rating / $\sqrt{2}$

To reverse sense or direction swap the connections to **one** phase. E.g. swap phase B with phase B'.

Control inputs

Pin 14 a

Direction control input. Pulling this input low will reverse the direction of rotation of the motor

Pin 14 c

Step pulse input. The motor will increment one step on a high to low transition on this input. The pulse should be low for 10 μ S minimum. Maximum frequency 20KHz.

Pin 16 a

Full/half step control input. If this input is high (or unconnected), full step drive will be generated giving 200 steps per revolution of a hybrid stepper motor. If it is pulled low, then half step drive will be generated giving 400 steps per revolution. This input would not normally be changed during use as the unit may enter a wave drive mode (full step with only one phase on). The use of half step reduces problems with resonance.

Pin 16 c

Reset input. Pulling this input low will set the internal logic to give the home phase output and therefore the home output will be on. This may also be used to reset an error condition such as overload or overtemperature.

Pin 18 a

Output disable input. Pulling this input low will disable the motor output current. There will then be no motor torque and it may be rotated by hand.

These control inputs are CMOS schmitt trigger inputs operating at +12V with 10K Ω pull-up resistors and diode isolation. The control options are as follows:

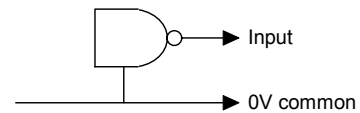

CMOS output operating at +12V

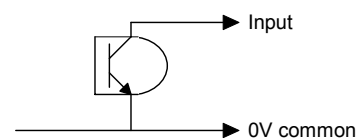

Open collector TTL output (e.g. 7406, 7407)

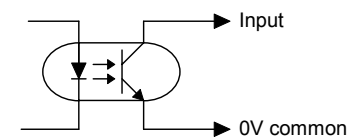

Opto isolator

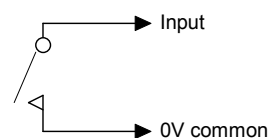

Switch

Monitor outputs

Pin 12 c

Home phase output. This output is low when the output phases are in their initial home state pattern. This state is repeated in four full steps or eight half steps.

Pins 20 a

Overload output. This output will go low and remain latched low, if an overload or short circuit is detected. The motor output will also be disabled. This condition may be reset by either pulling the reset input low or removing the power

Pins 20 c

Overtemperature output. This output will go low if the thermal sensor option is fitted and the heatsink gets too hot. This condition may be latched by setting SW1-2 (LT) on so that the drive doesn't suddenly become active when the heatsink cools. This condition may be reset by either pulling the reset input low or removing the power. The motor output may also be disabled automatically by setting SW1-1 (DT) on. If no thermal sensor is fitted then this output will be low.

Current programming

Pin 18 c

Current program input. The motor current may be reduced from the value set on the DIP switch by connecting a resistor from this input to 0V. This may be used to set the phase current by the connector the unit is plugged into, or to reduce the motor current on application of an external signal such as at standstill.

Multi-axis synchronisation

Pin 12 a

Sync input/output. This connection may be used to synchronise the chopping frequency between a number of drive cards by connecting them together. One drive is selected as the master; the others are slaves and should have their chopping oscillators disabled by setting SW1-4 on.

Auxiliary power outputs

Pin 26 a

Auxiliary +12V output. 50mA maximum.

Pin 26 c

Auxiliary +5V output. 50mA maximum.

On board oscillator (option)

Pin 22 a

VCO speed control input. Applying a control voltage between 0V and +12V will proportionally vary the output frequency of the voltage controlled oscillator (if fitted).

Pin 22 c

VCO output. This 12V CMOS output of the voltage controlled oscillator (if fitted) may be connected directly to the step pulse input (14 c).

Pin 24a

VCO base speed control. A resistance to 0V sets the base speed of the voltage controlled oscillator (if fitted).

Pin 24 c

VCO run/stop input. Pulling this input low enables the voltage controlled oscillator (if fitted).

Configuration

A four way DIP switch is provided for certain configuration options.

SW1-1 (DT)

Disable on overtemperature. If this switch is on and the thermal sensor (option) gets too hot, then the motor output will be automatically disabled to prevent overheating. If no thermal sensor is fitted, then this should be left off.

SW1-2 (LT)

Latch overtemperature. If this switch is on and the thermal sensor (option) gets too hot, then the overtemperature condition will be latched. This will prevent unexpected re-energisation of the drive, when the heatsink cools back down. The latched condition may be reset by either pulling the reset input low or removing the power.

SW1-3 (CC)

Current control type. This switch determines whether the current control chopping is executed on the upper drive transistors or the lower drive transistors. This would normally be left off for more efficient use, but may have small advantages of current control on low current settings.

SW1-4 (SS)

Slave sync. If this switch is on, the chopping oscillator is inhibited. This should only be used on slave units in multi-axis synchronised systems, where another unit provides a master chopping signal.

Motor current setting

The output current per phase is normally set using a four way DIP switch as follows:

Switch setting				Nominal output current per phase
SW2-1	SW2-2	SW2-3	SW2-4	
off	off	off	off	0.0A
off	off	off	on	0.5A
off	off	on	off	0.9A
off	off	on	on	1.2A
off	on	off	off	1.3A
off	on	off	on	1.6A
off	on	on	off	1.85A
off	on	on	on	2.1A
on	off	off	off	2.3A
on	off	off	on	2.5A
on	off	on	off	2.7A
on	off	on	on	2.9A
on	on	off	off	3.0A
on	on	off	on	3.1A
on	on	on	off	3.3A
on	on	on	on	3.5A

The above settings are approximate and may be influenced by the motor's resistance and inductance. The output current should ideally be checked during commissioning, using an analogue meter.

The motor current may be reduced from the value set on the DIP switch by connecting a resistor from the current program input to 0V. This may be used to set the phase current by the connector the unit is plugged into, or to reduce the motor current on application of an external signal such as at standstill.

The external resistor should be selected to give the required voltage on the current program input of approximately 0.47 x required current per phase.

Thermal protection (user fit option)

A thermal sensor may be fitted to prevent overheating of the heatsink and output devices. The sensor should be a switching type that opens on excessive temperature such as AIRPAX type 67L080, that operates at 80°C. This device may be clipped onto the heatsink bracket and soldered into the location SW3.

This feature will give a warning on the overtemperature output, that the heatsink is too hot. This condition may be latched by setting switch SW1-2 (LT) on. The drive may be automatically disabled on overtemperature by setting switch SW1-1 on.

Status LED's (user fit option)

Provision has been made for the user to fit five status light emitting diodes. These may be soldered into their locations at the front of the board.

LED1	green	power is on
LED2	yellow	output is disabled
LED3	red	overtemperature fault detected
LED4	red	overload fault detected
LED5	yellow	home phase output

On board oscillator (user fit option)

A simple voltage controlled oscillator may be constructed on the drive board by the addition of a few components. These parts are located at the lower front of the board at the edge and may be soldered in without removal of the heatsink. The output of this oscillator may be connected directly to the step pulse input (pin 14c).

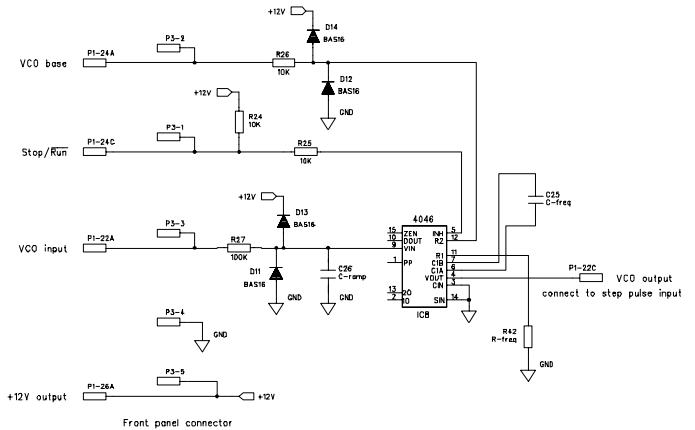

Oscillator external controls

The external controls for the oscillator may be connected via the 32 way DIN41612 connector or alternatively, if front panel controls are required, may be connected via a 5 pin MOLEX connector (P3).

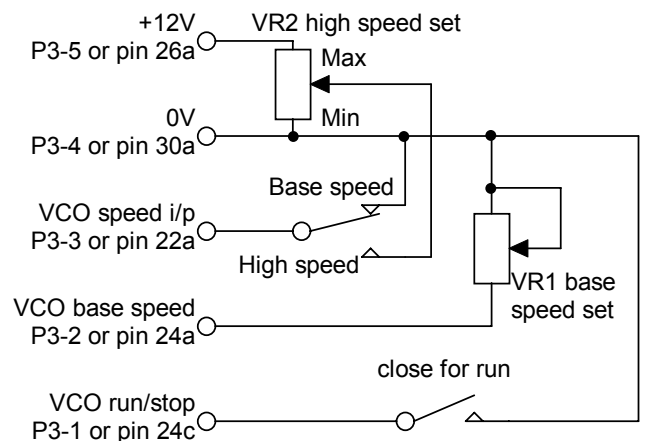

Oscillator operation

The normal method of oscillator operation is as follows:

1. The oscillator is started at the base speed by switching the run switch on with the base/high speed switch set to base. This base speed is a frequency offset and should be chosen to be safely within the pull-in capability of the motor/drive combination, and ideally above the resonant frequency range. This base speed is defined by C-freq and the setting of VR1.
2. The high speed may be selected by switching the base/high speed switch to high. The oscillator will then ramp up to the high speed. This high speed is set by VR2, whose range is defined by R-freq and C-freq. The ramp rate is determined by the time constant of R27 (100K Ω) and C-ramp.
3. The oscillator may then be slowed back down to the base speed by switching the base/high speed back to base.
4. When the speed has dropped down to the base setting the oscillator may be inhibited by switching the run switch off. The motor should only be started, stopped or have a direction change whilst at the base speed.

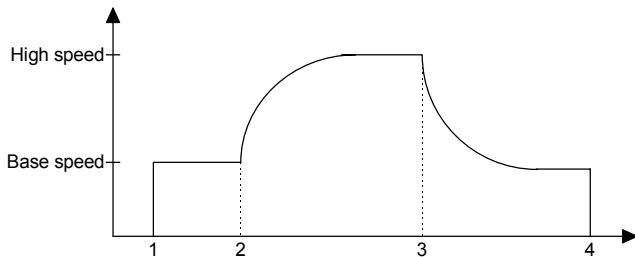

Component selection

The following components need to be soldered onto the PCB:

IC8	CD4046 CMOS PLL IC (used as VCO)
R-freq	resistor 1K Ω -1M Ω (typ 5.6K Ω)
C-freq	capacitor >100pF (typ 10nF)
C-ramp	capacitor (typ 10 μ F)
P3	optional molex connector if using front panel controls

The following external components are required to complete the oscillator:

VR1	pot	0 - 1M Ω	(typ 1 M Ω)
VR2	pot	1 K Ω	

First determine the base speed and the maximum high speed you wish to obtain.

Using the graph below select a value for C-freq for the chosen pot VR1

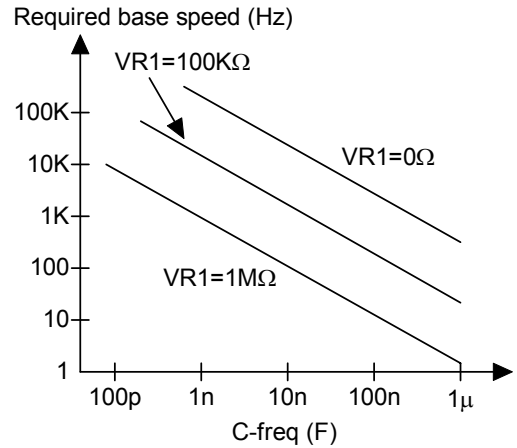

Then from the ratio of the maximum running speed to the base speed, use the following graph to select R-freq.

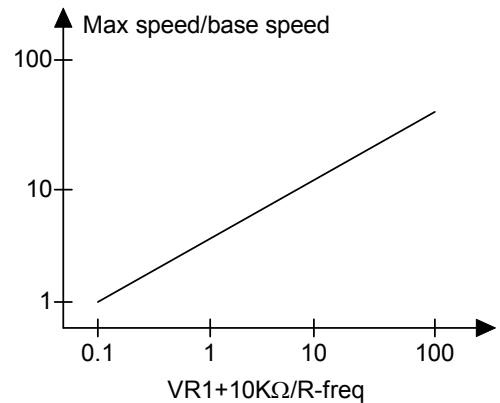

Caution!

1. SERIOUS DAMAGE WILL OCCUR if any motor lead is connected or becomes disconnected whilst the drive is energised.
2. The drive board should always be mounted such that the heatsink fins are vertical i.e. with the board on edge, and adequate clearance be given top and bottom i.e. 25 mm minimum. When rack mounting the board there should be at least a 15 mm clearance between the heatsink and an adjacent board. If the airflow around the unit is restricted, then force air cooling should be employed.
3. When using the drive at high ambient temperatures or at slow speeds or at standstill, whilst at high current settings, it will prove advantageous to employ forced air cooling.
4. Motor and power supply connections should be made with at least 32/0.2 mm wire due to the high peak currents flowing. All other control wiring may use 7/0.2 mm.
5. Good engineering practices should be employed in the commissioning of this product and should be made to adhere to all relevant regulations.