

AGR26125E

125 W, 2.5 GHz—2.7 GHz, N-Channel E-Mode, Lateral MOSFET

Introduction

The AGR26125E is a high-voltage, gold-metalized, enhancement mode, laterally diffused metal oxide semiconductor (LDMOS) RF power transistor suitable for ultrahigh-frequency (UHF) applications including multichannel multipoint distribution service (MMDS) for broadcasting and communications.

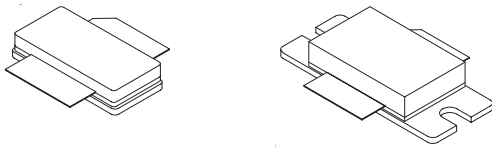

AGR26125EU (unflanged) AGR26125EF (flanged)

Figure 1. Available Packages

Features

Typical pulsed P1dB, 6 μ s pulse at 10% duty: 125 W.
Typical performance for MMDS systems.
f = 2600 MHz, I_{DQ} = 1300 mA, V_{ds} = 28 V,
adjacent channel BW = 3.84 MHz, 5 MHz offset;
alternate channel BW = 3.84 MHz, 10 MHz offset.
Typical P/A ratio of 9.8 dB at 0.01% (probability)
CCDF*:

- Output power: 20 W
- Power gain: 11.5 dB.
- Power Added Efficiency (PAE): 19%.
- ACLR1: -35 dBc.
- ACLR2: -37 dBc.

High-reliability, gold-metalization process.

Low hot carrier injection (HCI) induced bias drift over 20 years.

Internally matched.

High gain, efficiency, and linearity.

Integrated ESD protection.

Device can withstand a 10:1 voltage standing wave ratio (VSWR) at 28 Vdc, 2600 MHz, 125 W continuous wave (CW) output power.

Large signal impedance parameters available.

*The test signal utilized is 4-channel W-CDMA Test Model 1. This test signal provides an equivalent reference (occupied bandwidth and waveform EPF) for the actual performance with an MMDS waveform.

Table 1. Thermal Characteristics

Parameter	Sym	Value	Unit
Thermal Resistance, Junction to Case:			
AGR26125EU	R _{θJC}	0.5	°C/W
AGR26125EF	R _{θJC}	0.5	°C/W

Table 2. Absolute Maximum Ratings*

Parameter	Sym	Value	Unit
Drain-source Voltage	V _{DSS}	65	Vdc
Gate-source Voltage	V _{GS}	-0.5, +15	Vdc
Total Dissipation at T _c = 25 °C:			
AGR26125EU	P _D	350	W
AGR26125EF	P _D	350	W
Derate Above 25 °C:			
AGR26125EU	—	2.0	W/°C
AGR26125EF	—	2.0	W/°C
Operating Junction Temperature	T _J	200	°C
Storage Temperature Range	T _{STG}	-65, +150	°C

* Stresses in excess of the absolute maximum ratings can cause permanent damage to the device. These are absolute stress ratings only. Functional operation of the device is not implied at these or any other conditions in excess of those given in the operational sections of the data sheet. Exposure to absolute maximum ratings for extended periods can adversely affect device reliability.

Table 3. ESD Rating*

AGR26125E	Minimum (V)	Class
HBM	500	1B
MM	50	A
CDM	1500	4

* Although electrostatic discharge (ESD) protection circuitry has been designed into this device, proper precautions must be taken to avoid exposure to ESD and electrical overstress (EOS) during all handling, assembly, and test operations. PEAK Devices employs a human-body model (HBM), a machine model (MM), and a charged-device model (CDM) qualification requirement in order to determine ESD-susceptibility limits and protection design evaluation. ESD voltage thresholds are dependent on the circuit parameters used in each of the models, as defined by JEDEC's JESD22-A114B (HBM), JESD22-A115A (MM), and JESD22-C101A (CDM) standards.

Caution: MOS devices are susceptible to damage from electrostatic charge. Reasonable precautions in handling and packaging MOS devices should be observed.

Electrical Characteristics

Recommended operating conditions apply unless otherwise specified: $T_c = 30\text{ }^\circ\text{C}$.

Table 4. dc Characteristics

Parameter	Symbol	Min	Typ	Max	Unit
Off Characteristics					
Drain-source Breakdown Voltage ($V_{GS} = 0$, $I_D = 400\text{ }\mu\text{A}$)	$V_{(BR)DSS}$	65	—	—	Vdc
Gate-source Leakage Current ($V_{GS} = 5\text{ V}$, $V_{DS} = 0\text{ V}$)	I_{GSS}	—	—	4	μA dc
Zero Gate Voltage Drain Leakage Current ($V_{DS} = 28\text{ V}$, $V_{GS} = 0\text{ V}$)	I_{DSS}	—	—	200	μA dc
On Characteristics					
Forward Transconductance ($V_{DS} = 10\text{ V}$, $I_D = 1\text{ A}$)	G_{FS}	—	9	—	S
Gate Threshold Voltage ($V_{DS} = 10\text{ V}$, $I_D = 400\text{ }\mu\text{A}$)	$V_{GS(TH)}$	—	—	4.8	Vdc
Gate Quiescent Voltage ($V_{DS} = 28\text{ V}$, $I_D = 1300\text{ mA}$)	$V_{GS(Q)}$	—	3.8	—	Vdc
Drain-source On-voltage ($V_{GS} = 10\text{ V}$, $I_D = 1\text{ A}$)	$V_{DS(ON)}$	—	0.08	—	Vdc

Table 5. RF Characteristics

Parameter	Symbol	Min	Typ	Max	Unit
Dynamic Characteristics					
Reverse Transfer Capacitance ($V_{DS} = 28\text{ V}$, $V_{GS} = 0$, $f = 1.0\text{ MHz}$) (This part is internally matched on both the input and output.)	C_{RSS}	—	3.0	—	pF
Functional Tests (in Supplied Test Fixture)					
Common-source Amplifier Power Gain*	G_{PS}	—	11.5	—	dB
Drain Efficiency*	η	—	20	—	%
Third-order Intermodulation Distortion* (IMD3 measured over 3.84 MHz BW @ $f_1 - 10\text{ MHz}$ and $f_2 + 10\text{ MHz}$)	IM3	—	-38	—	dBc
Adjacent Channel Power Ratio* (ACPR measured over BW of 3.84 MHz @ $f_1 - 5\text{ MHz}$ and $f_2 + 5\text{ MHz}$)	ACPR	—	-41	—	dBc
Input Return Loss*	IRL	—	-15	—	dB
Power Output, 1 dB Compression Point ($V_{DD} = 28\text{ V}$, $f_c = 2600.0\text{ MHz}$, 6 μs pulse at 10% duty)	P_{1dB}	—	125	—	W
Output Mismatch Stress ($V_{DD} = 28\text{ V}$, $P_{OUT} = 125\text{ W (CW)}$, $I_{DQ} = 1300\text{ mA}$, $f_c = 2600.0\text{ MHz}$ VSWR = 10:1; [all phase angles])	ψ	No degradation in output power.			

* 3GPP W-CDMA, typical P/A ratio of 8.5 dB at 0.01% CCDF, $f_1 = 2590.0\text{ MHz}$, and $f_2 = 2600\text{ MHz}$. $V_{DD} = 28\text{ Vdc}$, $I_{DQ} = 1300\text{ mA}$, and $P_{OUT} = 20\text{ W avg}$.

Electrical Characteristics

Recommended operating conditions apply unless otherwise specified: $T_c = 30\text{ }^\circ\text{C}$.

Table 4. dc Characteristics

Parameter	Symbol	Min	Typ	Max	Unit
Off Characteristics					
Drain-source Breakdown Voltage ($V_{GS} = 0$, $I_D = 200\ \mu\text{A}$)	$V_{(BR)DSS}$	65	—	—	Vdc
Gate-source Leakage Current ($V_{GS} = 5\text{ V}$, $V_{DS} = 0\text{ V}$)	I_{GSS}	—	—	4	μA dc
Zero Gate Voltage Drain Leakage Current ($V_{DS} = 28\text{ V}$, $V_{GS} = 0\text{ V}$)	I_{DSS}	—	—	12	μA dc
On Characteristics					
Forward Transconductance ($V_{DS} = 10\text{ V}$, $I_D = 1\text{ A}$)	G_{FS}	—	9	—	S
Gate Threshold Voltage ($V_{DS} = 10\text{ V}$, $I_D = 400\ \mu\text{A}$)	$V_{GS(TH)}$	—	—	4.8	Vdc
Gate Quiescent Voltage ($V_{DS} = 28\text{ V}$, $I_D = 1300\text{ mA}$)	$V_{GS(Q)}$	—	3.8	—	Vdc
Drain-source On-voltage ($V_{GS} = 10\text{ V}$, $I_D = 1\text{ A}$)	$V_{DS(ON)}$	—	0.08	—	Vdc

Table 5. RF Characteristics

Parameter	Symbol	Min	Typ	Max	Unit
Dynamic Characteristics					
Reverse Transfer Capacitance ($V_{DS} = 28\text{ V}$, $V_{GS} = 0$, $f = 1.0\text{ MHz}$) (This part is internally matched on both the input and output.)	C_{RSS}	—	3.0	—	pF
Functional Tests (in Agere Systems Supplied Test Fixture)					
Common-source Amplifier Power Gain*	G_{PS}	—	11.5	—	dB
Drain Efficiency*	η	—	20	—	%
Third-order Intermodulation Distortion* (IMD3 measured over 3.84 MHz BW @ $f_1 - 10\text{ MHz}$ and $f_2 + 10\text{ MHz}$)	IM3	—	-38	—	dBc
Adjacent Channel Power Ratio* (ACPR measured over BW of 3.84 MHz @ $f_1 - 5\text{ MHz}$ and $f_2 + 5\text{ MHz}$)	ACPR	—	-41	—	dBc
Input Return Loss*	IRL	—	-15	—	dB
Power Output, 1 dB Compression Point ($V_{DD} = 28\text{ V}$, $f_c = 2600.0\text{ MHz}$, 6 μs pulse at 10% duty)	P_{1dB}	—	125	—	W
Output Mismatch Stress ($V_{DD} = 28\text{ V}$, $P_{OUT} = 125\text{ W}$ (CW), $I_{DQ} = 1300\text{ mA}$, $f_c = 2600.0\text{ MHz}$ VSWR = 10:1; [all phase angles])	ψ	No degradation in output power.			

* 3GPP W-CDMA, typical P/A ratio of 8.5 dB at 0.01% CCDF, $f_1 = 2590.0\text{ MHz}$, and $f_2 = 2600\text{ MHz}$. $V_{DD} = 28\text{ Vdc}$, $I_{DQ} = 1300\text{ mA}$, and $P_{OUT} = 20\text{ W}$ avg.

125 W, 2.5 GHz–2.7 GHz, N-Channel E-Mode, Lateral MOSFET

AGR26125E Component Layout

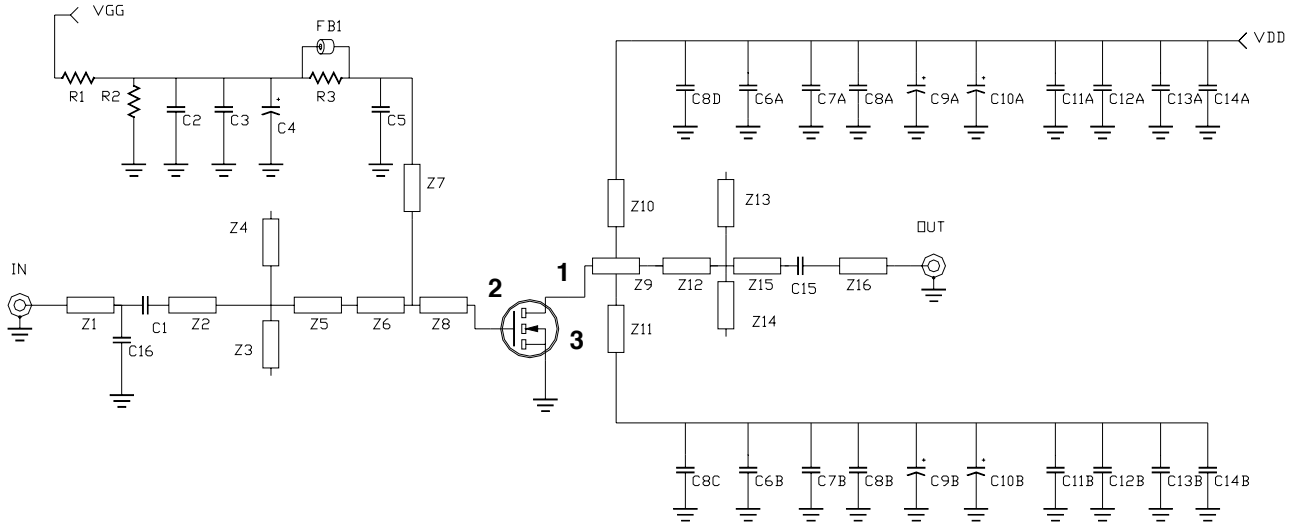

PINS: 1. DRAIN, 2. GATE, 3. SOURCE

A. Schematic

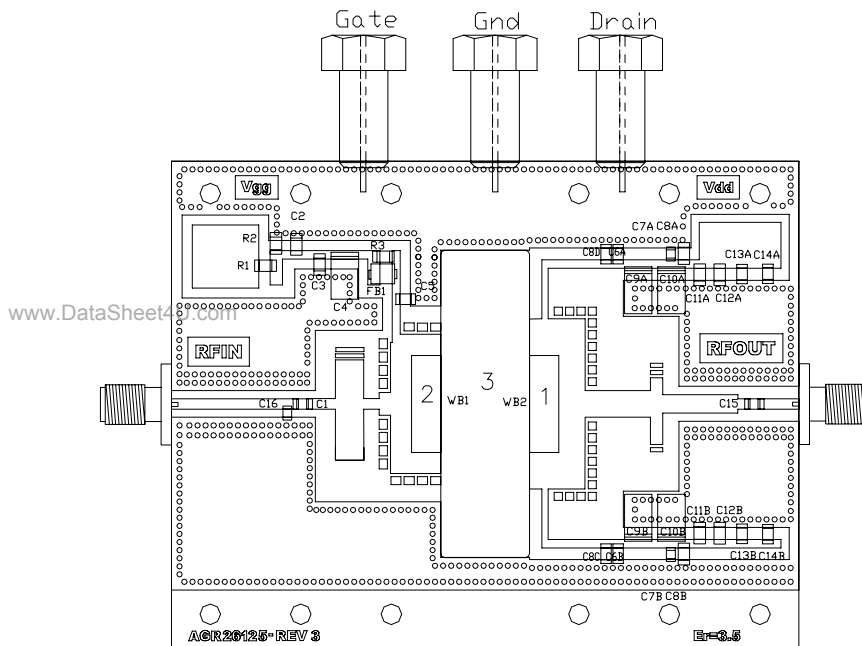

Parts List:

- Microstrip Line: Z1: 0.785 in. x 0.066 in.; Z2: 0.180 in. x 0.066 in.; Z3: 0.315 in. x 0.176 in.; Z4: 0.238 in. x 0.176 in.; Z5: 0.096 in. x 0.066 in.; Z6: 0.070 in. x 0.140 in.; Z7: 0.216 in. x 0.050 in.; Z8: 0.310 in. x 0.860 in.; Z9: 0.342 in. x 1.050 in.; Z10: 0.723 in. x 0.038 in.; Z11: 0.723 in. x 0.038 in.; Z12: 0.405 in. x 0.165 in.; Z13: 0.103 in. x 0.076 in.; Z14: 0.194 in. x 0.076 in.; Z15: 0.465 in. x 0.114 in.; Z16: 0.252 in. x 0.066 in.
- ATC® chip capacitor: C1: 6.8 pF series 100B; C5, C6A, C6B, C13A, C13B, C14A, C14B, C15: 4.7 pF series 100B; C7A, C7B: 1.2 pF series 100B; C16: 0.4 pF series 100A.
- Murata® capacitor C8A, C8B: 0.01 μF case 0805.
- Vitramon® capacitor C3: 22000 pF case 1206
- Kemet® capacitor C4, C9A, C9B, C10A, C10B: 22 μF, 35V; C2, C11A, C11B, C12A, C12B: 0.1 μF case 1206.
- Fair-Rite® ferrite bead: FB1: 2743019447.
- 1206 chip resistor: R1: 1 kΩ; R2: 560 kΩ; R3: 4.7 Ω.
- WB1, WB2: 10 mil thick, 0.6 in. x 0.18 in.
- Taconic® RF-35 board material, 1 oz. copper, 30 mil thickness, $\epsilon_r = 3.5$

B. Component Layout

Figure 2. AGR26125E Component Layout

Typical Performance Characteristics

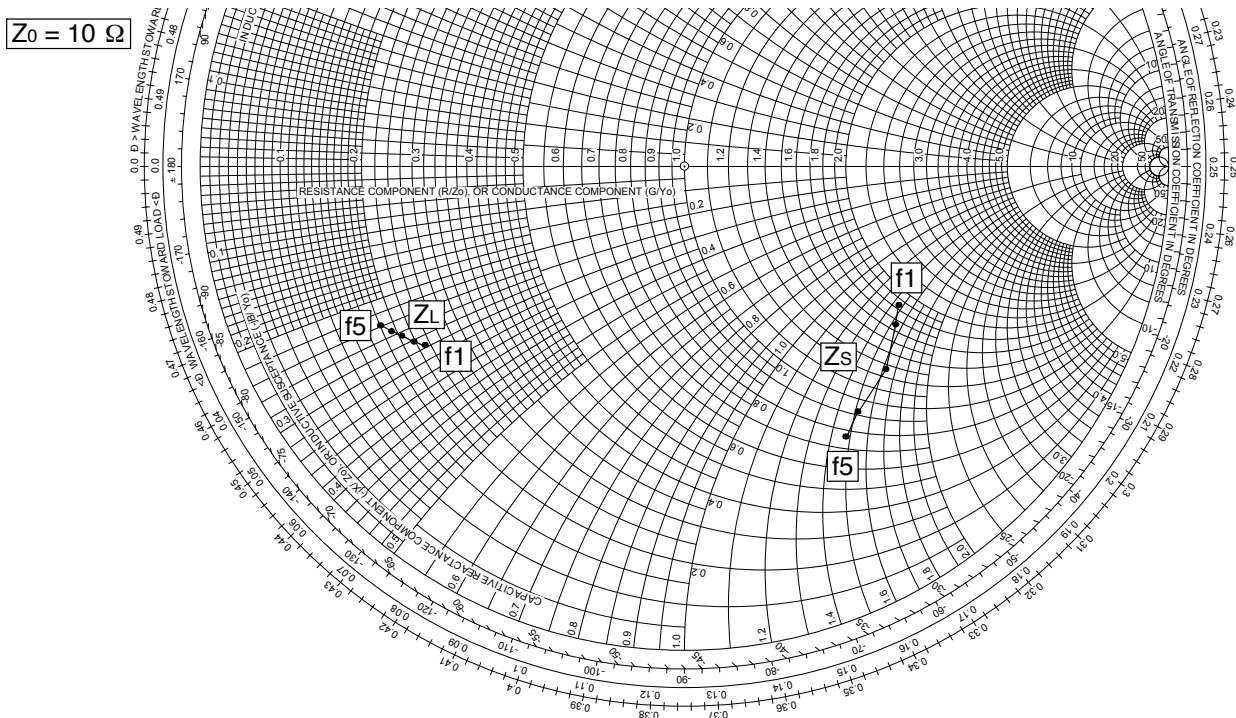

MHz (f)	$Z_s \Omega$ (complex source impedance)	$Z_L \Omega$ (complex optimum load impedance)
2500 (f1)	18.0 – j14.9	2.5 – j3.7
2535 (f2)	15.7 – j15.8	2.3 – j3.5
2595 (f3)	12.0 – j16.0	2.1 – j3.2
2655 (f4)	9.0 – j15.3	1.9 – j2.9
2700 (f5)	7.5 – j14.6	1.7 – j2.7

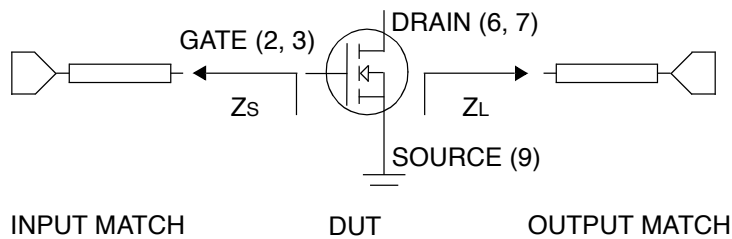

Figure 3. Series Equivalent Input and Output Impedances

125 W, 2.5 GHz–2.7 GHz, N-Channel E-Mode, Lateral MOSFET

Typical Performance Characteristics (continued)

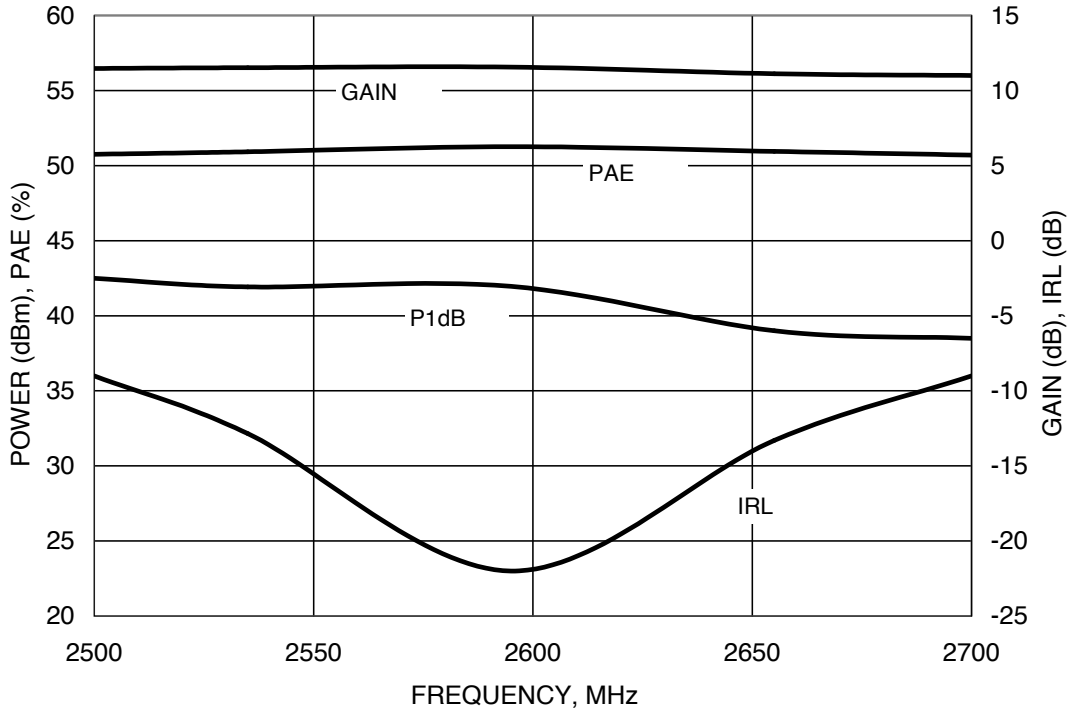
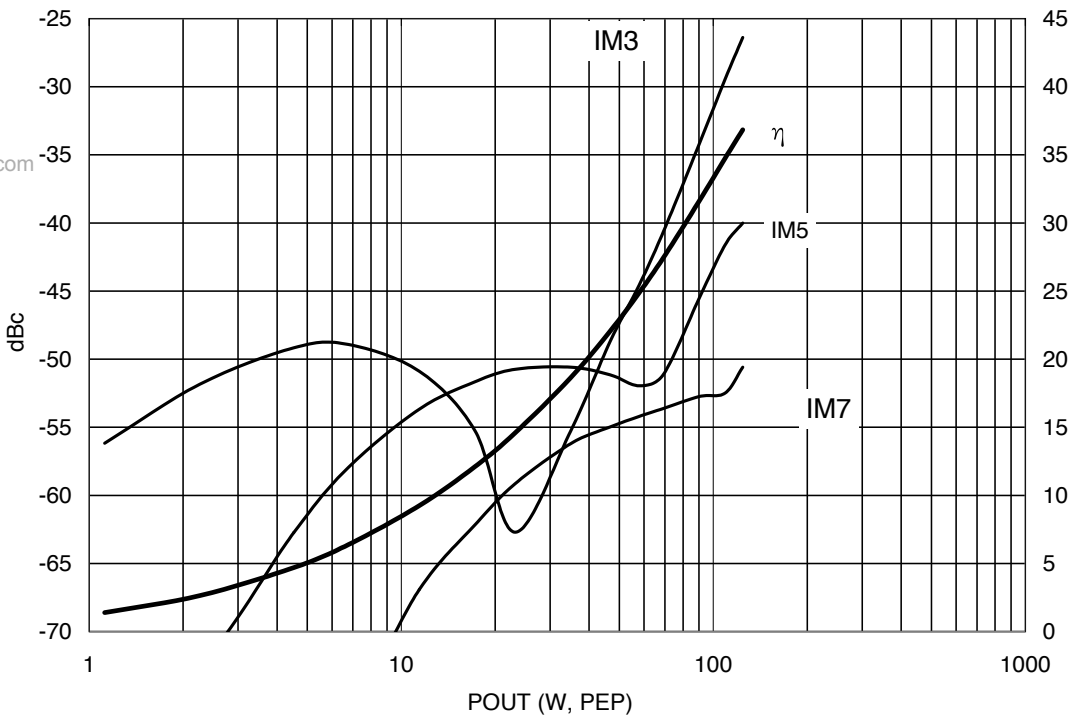

Figure 4. CW Broadband Performance



Test Conditions:
Two-tone measurement @ 10 MHz tone spacing, $V_{DD} = 28$ Vdc, $F_1 = 2590$ MHz, $F_2 = 2600$ MHz.

Figure 5. Two-tone IMD vs. Power

Typical Performance Characteristics (continued)

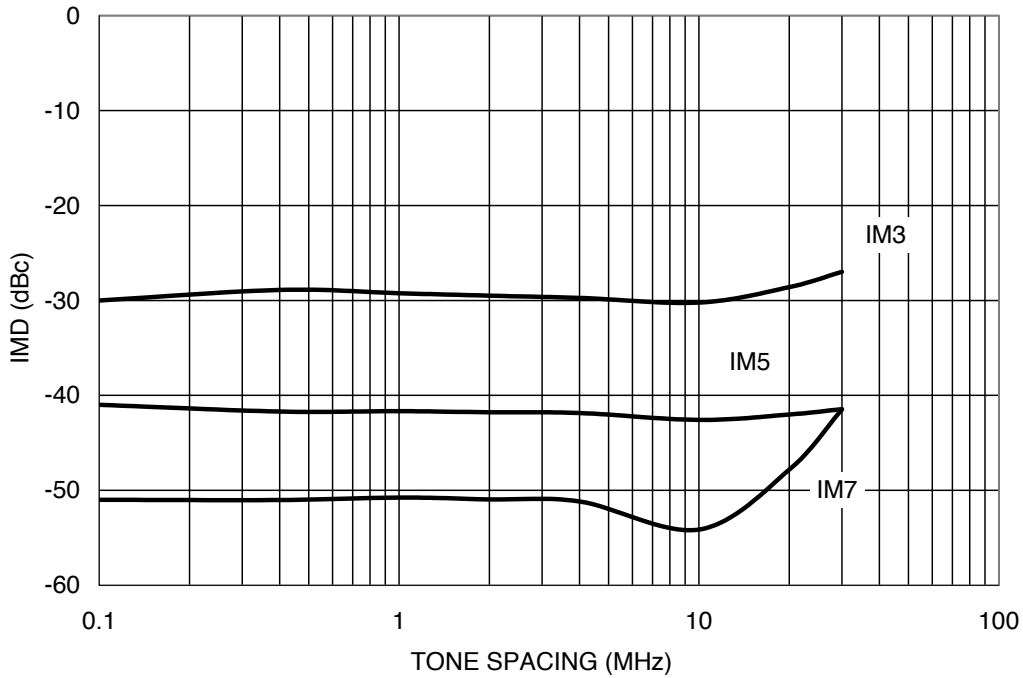

Test Conditions:
 $V_{DD} = 28\text{ V}$, $I_{DQ} = 1200\text{ mA}$, $P_{OUT} = 110\text{ W (PEP)}$, $F = 2595\text{ MHz}$.

Figure 6. Two-tone IMD vs. Tone Spacing

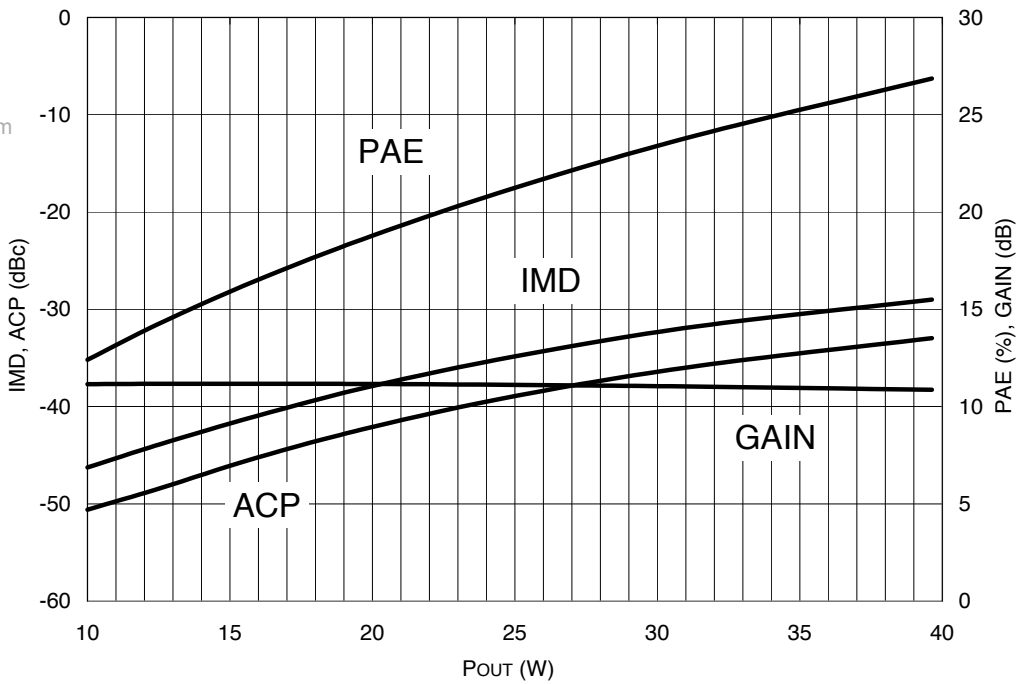

Test Conditions:
 Two-carrier W-CDMA 3GPP, peak-to-average = 8.5 dB @ 0.01% CCDF, $F_1 = 2590\text{ MHz}$, $F_2 = 2600\text{ MHz}$; $V_{DD} = 28\text{ V}$, $I_{DQ} = 1200\text{ mA}$.

Figure 7. Two-carrier W-CDMA Performance

125 W, 2.5 GHz–2.7 GHz, N-Channel E-Mode, Lateral MOSFET

Typical Performance Characteristics (continued)

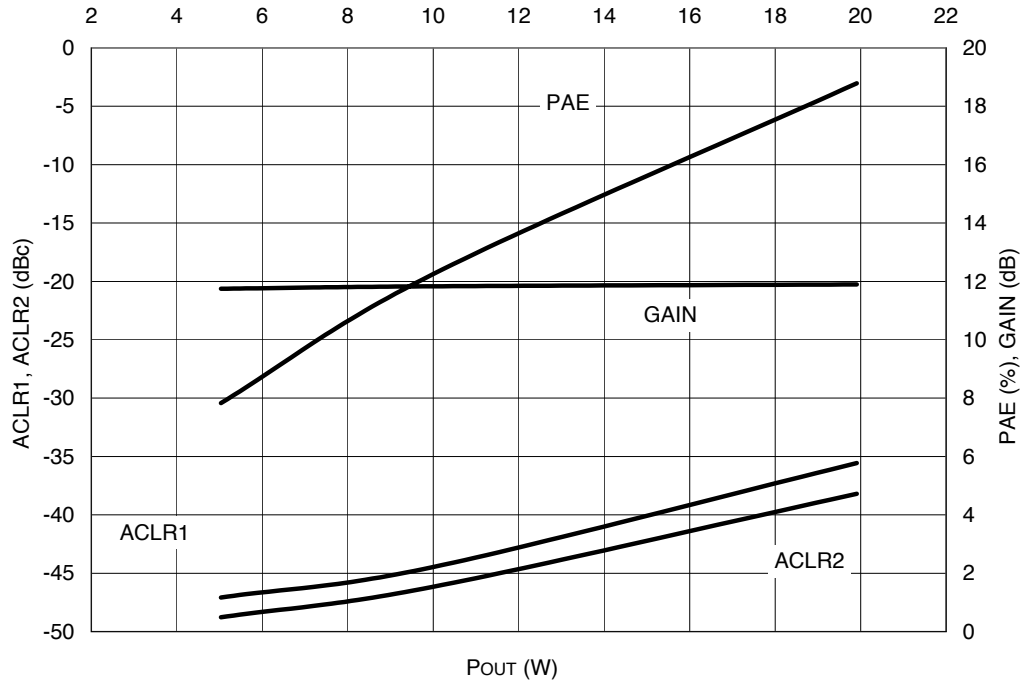

Test Conditions:
 Four-carrier W-CDMA 3GPP test model 1, peak-to-average = 9.8 dB @ 0.01% CCDF, F = 2595 MHz, VDD = 28 V, IDQ = 1200 mA.

Figure 8. Four-carrier W-CDMA Performance

Package Dimensions

All dimensions are in inches. Tolerances are ± 0.005 in. unless specified. Cut lead indicates drain.

AGR26125EU

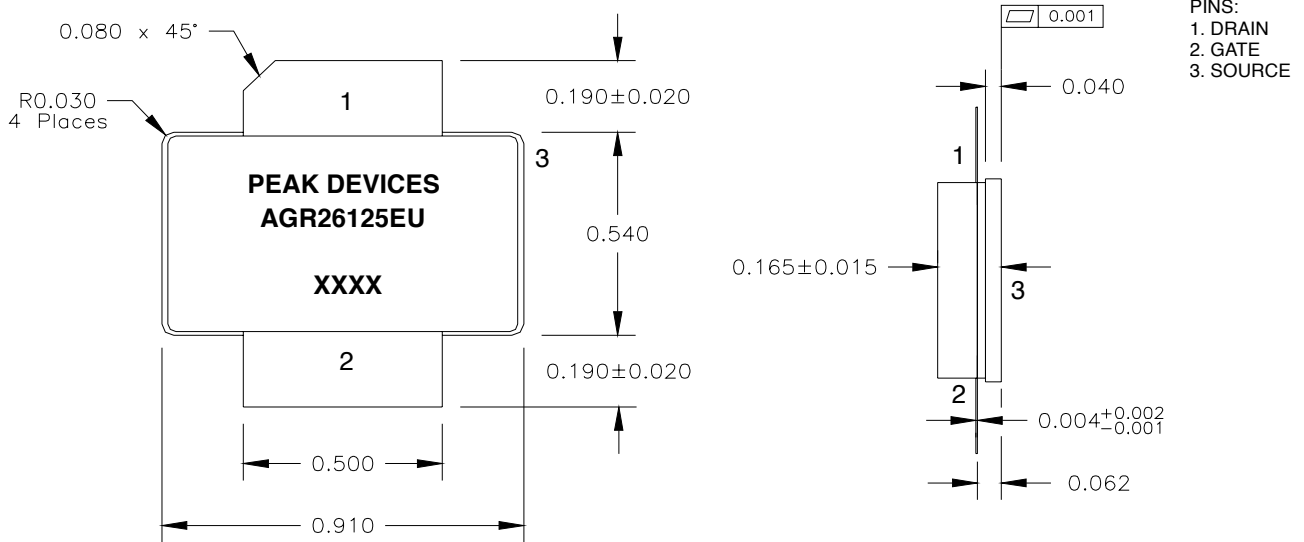

AGR26125EF

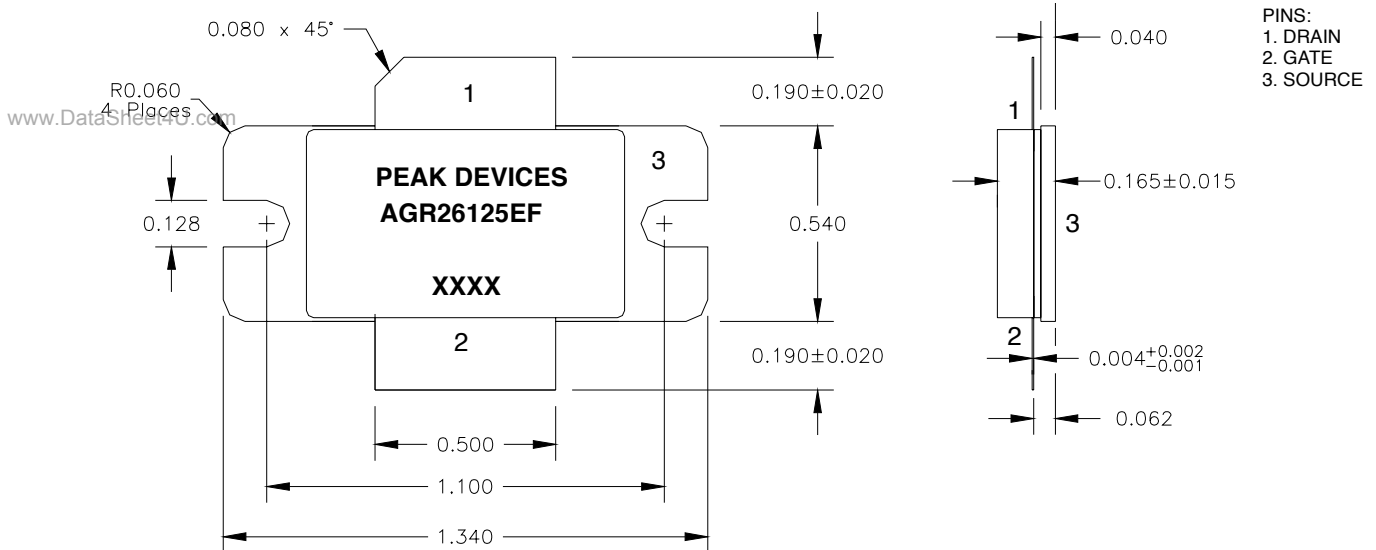

XXXX = 4 DIGIT TRACE CODE